

**K.C.S.E
CHEMISTRY
PAST PAPERS & MAKING SCHEME
PAPER 233/1, 233/2**

**Chemistry paper 233/1
K.C.S.E 1995 QUESTIONS**

- The electron arrangement ions X^{3-} and Y^{2-} are 2, 8, and 2, 8, 8 respectively.
 - Write the electronic arrangement of the elements X and Y. (2 mks)
 - Write the formula of the compound that would be formed between X and Y.
- When bromine gas reacts with aqueous sodium hydroxide, the *equilibrium* represented by the equation: $Br_2(aq) + 2OH^-(aq) \rightleftharpoons Br^-(aq) + OBr^-(aq) + H_2O$ is established.

What observations would be made if a few drops of sulphuric acid were added to the equilibrium mixture? Explain.
- Calculate the amount of calcium carbonate that would remain if 15.0g of calcium carbonate were reacted with 0.2 moles of hydrochloric acid.

The equation for the reaction is $CaCO_3(g) + 2HCl \rightarrow CaCl_2(aq) + CO_2(g) + H_2O(g)$ (C = 12.0 = 1.60, Ca = 40.0)
- In an experiment, soap solution was added to three separate samples of water. The table below shows the volumes of soap solution required to form lather with 1000cm³ of each sample of water before and after boiling.

	Sample I	Sample II	Sample III
Volume of soap before water is boiled (cm ³)	27.0	3.0	10.6
Volume of soap after water is boiled	27.0	3.0	3.0

- Which water sample is likely to be soft? Explain. (2mks)
 - Name the change in the volume of soap solution used in sample III (1mk)
- Name one natural fibre.
 - Give one advantage of synthetic fibres over natural fibres. (1mk)

The table below gives some properties of gases D and E.

Gas	Density	Effects of $H_2SO_4(aq)$	Effects of $NaOH(aq)$
D	Lighter than air	Reacts to form a salt	Dissolves without reacting
E	Heavier than air	Not affected	Not affected.

- Describe how you would obtain a sample of E from a mixture of gases D and E. (2mks)
- Suggest a possible identity of gas D. Give a reason for your answer. (1mk)

7. The curve below represents the variation of temperature with time when pure and impure samples of a solid were heated separately.

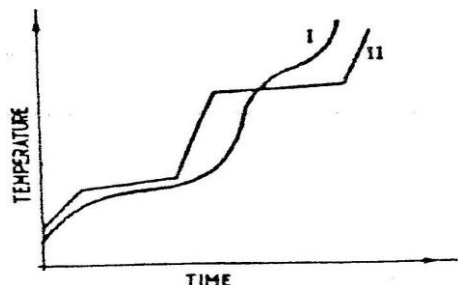

Which curve shows the variation in temperature for the pure solid? Explain (2mks)

8. The diagram below represents a set – up that can be used to prepare and collect oxygen.

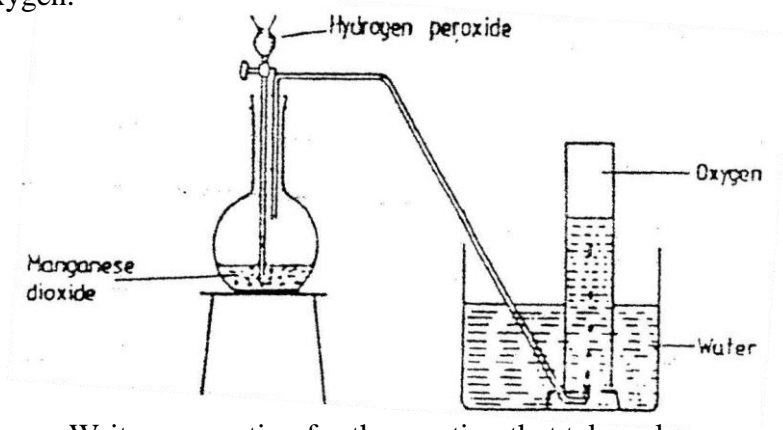

- Write an equation for the reaction that takes place (1mk)
 - What property of oxygen makes it possible for its collection as indicated by the diagram (1mk)
 - Explain why it is important not to collect any gas for the first few seconds of the experiment. (1mk)
9. Study the set – up below and answer the question that follows.

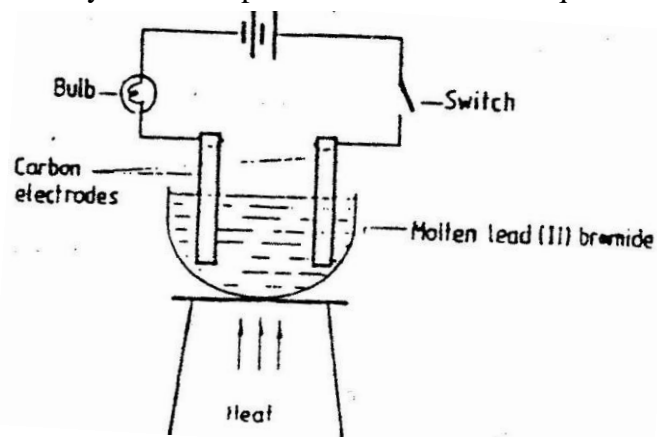

State and explain the observations that would be made when the circuit is completed.

10. In an experiment, rods of metals P, Q and R were cleaned with sand paper and placed in a beaker containing water. Another set of rods was also cleaned and placed in a beaker containing dilute acid. After placing the rods in the two liquids

bubbles of gas were seen around some of the rods as shown in the diagrams below.

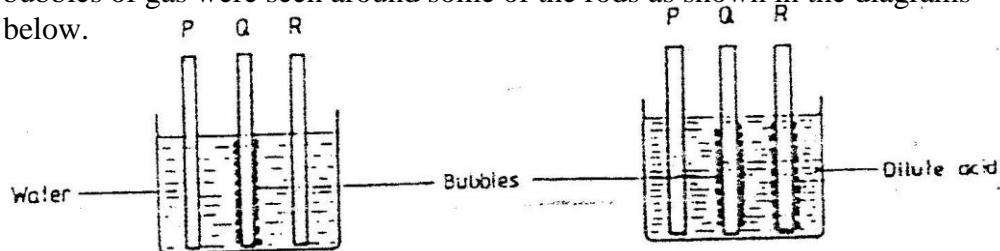

- a) Why is it necessary to clean the rods with sand paper before dipping them into the liquids. (1mk)
 - b) Arrange the three metals in order of their reactivity starting with the most reactive.
11. A Solution of chlorine in tetra chloromethane turns colourless when propene gas is bubble through it.
 - a) What type of reaction takes place? (1mk)
 - b) Write an equation for the above reaction (1mk)
 12. With reference to atomic number of one, explain why hydrogen can be placed in either group I and VII of the periodic table. (2mks)
 13. a) Explain why it is not advisable to use wood ash for cleaning aluminium Utensils (2mks)
 - b) Duralumin is an alloy of aluminium. What is the advantage of using duralumin in place of aluminium for manufacture of aeroplane parts. (1mk)
 14. A compound has an empirical formula, C_3H_6O and a relative formula mass of 16. Determine its molecular formula ($H = 1.0, C = 12.0, O = 16.0$) (2mk)
 15. Explain how you would separate mixture of nitrogen and oxygen gases given that their boiling points are $-196^\circ C$ and $183^\circ C$ respectively (2mks)
 16. Study the table below and answer the questions that follow.

Alkane	Formula	Heat of combustion (H_c) $kJmol^{-1}$
Methane	CH_4	890
Ethane	C_2H_6	1560
Propane	C_3H_8	2220
Butane	C_4H_{10}	

- a) Predict the heat of combustion of butane and write it on the space provided in the table above? (1mk)
- b) What does the sign of H_c value indicate about combustion of alkenes? (1mk)

The diagram below represents the extraction of sulphur by Frasch process 17.

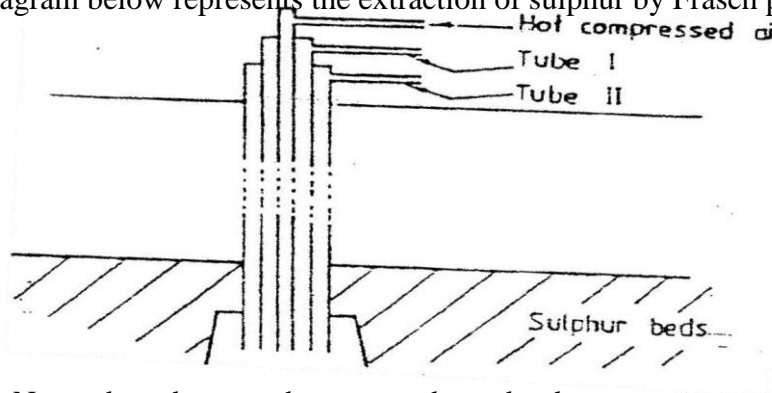

a) Name the substance that passes through tube;
I

II

b) What is the purpose of hot compressed air in this process? (1mk)

18. Study the diagram below and answer the questions that follow.

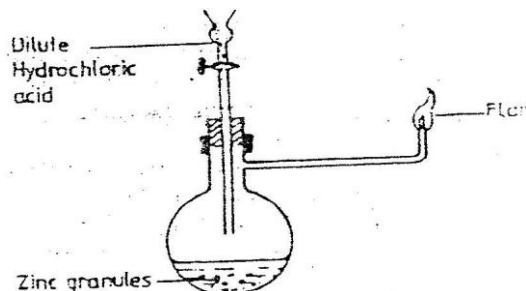

Write an equation for each of the two reactions that take place in the experiment represented by the diagram above (2mks)

19. A mixture containing equal volumes of hydrogen and carbon dioxide was introduced one end of a tube as shown below.

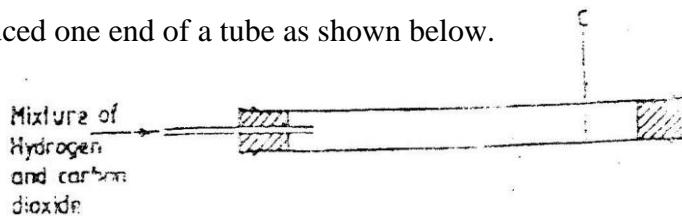

Which gas would be detected at point C in first? Explain (2mks)

20. The table below gives three experiments on the reaction of excess sulphuric acid and 0.5g of zinc done under different conditions. In each the volume of gas was recorded at different time intervals.

Experiment	Form of Zinc	Sulphuric acid solution
I	Power	0.8m
II	Power	1.0m
III	Granules	0.8m

On the axis below draw and label the three curves that could be obtained from such results.

21. The table shows how solubility of some substances in water varies with temperature.

Substance	Change of O°C	Solubility 20°C	With temperature 40°C	(g/100cm ³ of water) 60°C
W	0.334 27.60	0.16 34.0	0.097	0.0058
X	35.70	36.0	40.0	45.5
Y			36.6	37.3

Which of the above substances is likely to be a gas? Explain (2mks)

22. Dilute nitric acid reacts with copper according to the equation;

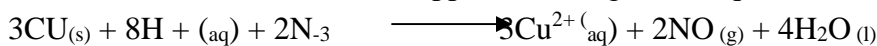

a) What is the oxidation number of nitrogen in?

i) 2N_3 ii) NO

b) With respect to nitrogen, explain whether the above reaction is an oxidation or reduction process. (1mk)

23. Explain the following observation. A chloride dissolves in water to form an electrolyte while the same chloride dissolves in methylbenzene to form a non-electrolyte. (1mk)

24. State what would be observed when dilute hydrochloric acid is added to the products formed when a mixture of iron filings and sulphur? (1mk)

25. Describe how the following reagents can be used to prepare lead sulphate solid potassium sulphate, solid lead carbonate, dilute nitric acid and distilled water.

26. Explain why the enthalpy of neutralization of ethanoic acid with sodium hydroxide is different from that of hydrochloric acid with sodium hydroxide.

(2mks)

27. Give a reason why calcium hydroxide solution is used to detect the presence of carbon dioxide gas while sodium hydroxide is NOT?

28. A compound $\text{C}_4\text{H}_{10}\text{O}$ is oxidized by excess acidified potassium permanganate to form another compound $\text{C}_4\text{H}_8\text{O}_2$. The same compound $\text{C}_4\text{H}_{10}\text{O}$ reacts with potassium to produce hydrogen gas.

a) Draw the structural formula and name the compound $\text{C}_4\text{H}_{10}\text{O}$ (1mk)

b) Write an equation for the reaction between potassium and compound $\text{C}_4\text{H}_{10}\text{O}$.

29. During the production of hydrogen iodide, hydrogen reacts with iodine according to the equation: $\text{H}_2_{(g)} + \text{I}_2_{(g)} \rightleftharpoons 2\text{HI}_{(g)}$; 52.0 kJ Explain how the following would affect the yield of hydrogen iodide: a) Increase in temperature

b) Increase in pressure. (2mks)

30. a) 100gm of radioactive ^{233}Pa was reduced to 12.5g after 81 days.

91

Determine the half-life of Pa. (2mks)

b) ^{233}Pa decays by beta emission. What is the mass number and

91

Atomic number of the element formed? (1mk)

CHEMISTRY K.C.S.E 1995 PAPER 233/2

QUESTIONS

1. The table below gives information on four elements by letters K, L, M and N. Study it and answer the questions that follow. The letters do not represent the actual symbols of the elements.

Element	Electron arrangement	Atomic radius (nm)	Ionic radius(nm)
K	2, 8, 2	0.136	0.065
L	2, 8, 7	0.099	0.181
M	2, 8, 8, 1	0.203	0.133
N	2, 8, 8, 2	0.174	0.099

- a) Which two elements have two similar properties? Explain (2mks)
- b) What is most likely formula of oxide of L? (1mk) C)
Which element is a non-metal? Explain (1 mk)
- d) Which one of elements is the strongest reducing agent? Explain (2mks)
- e) Explain why ionic radius of N is less than that of M (2mks)
- f) Explain why the ionic radius of L is bigger than its atomic radius (2mks) 2 a) IN an experiment hydrogen chloride gas was prepared and reacted with

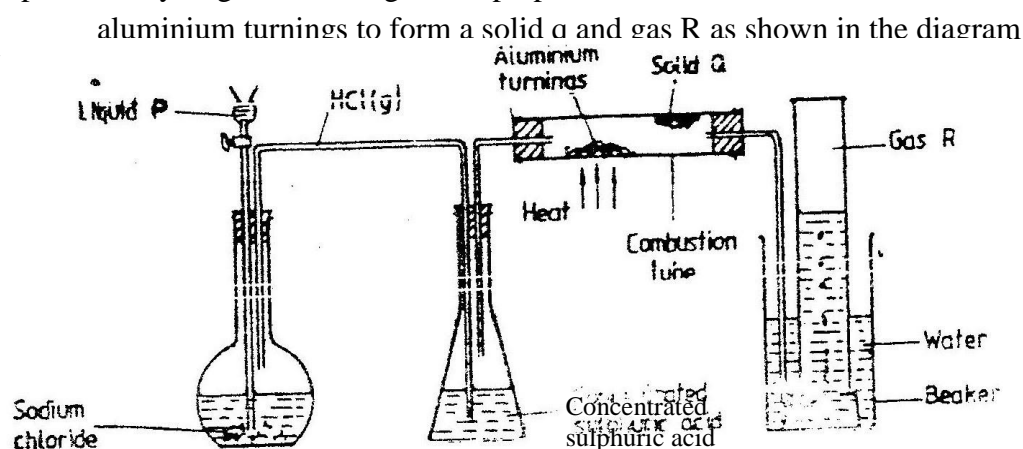

- (i) Name: Liquid P
: Solid Q (1mk)
: Gas R (1mk)
- (ii) Name another substance that could serve the same purpose as the concentrated sulphuric acid. (1mk)
- (iii) Explain the following observation. When blue litmus paper was dipped into the water in the beaker at the end of the experiment it turned red.
Explain why solid Q collects farther away from the heated aluminium (2mks)
- (b) (i) Write an equation for the reaction that takes place between ammonia gas and hydrogen gas (1mk)

- (ii) Calculate the mass of the product that would be formed when 2000cm³ of hydrogen chloride gas reacts completely with excess ammonia gas (H=1, O; N= 14.0, Cl = 35.5, one mole of gas occupied 24 litres at room temperature and pressure.) (3mks)

3. In an experiment to determine the heat of combustion of methanol, CH₂OH a student used a set up like the one shown in the diagram below.

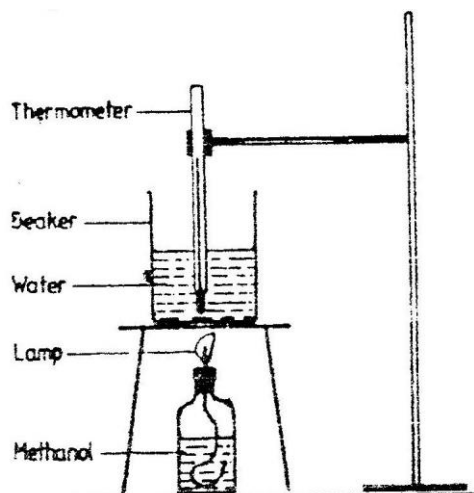

Volume of water =

500cm³

Final temperature of water = 27.0°C

Initial temperature of water = 20.0°C

Final mass of lamp + methanol = 22.11g

Initial mass of lamp + methanol = 22.98g

Density of water = 1.0g cm³

- a) Write an equation for the combustion of methanol
- b) Calculate:
- The number of moles of methanol used in this experiment (C = 12; O = 16; H = 1)
 - The heat of combustion per mole of methanol. (1mk)
 - The heat of combustion per mole of methanol (2mks)
- c) Explain why the value of the molar heat of combustion for methanol obtained in this experiment is different from the theoretical value.
- d) On the axis below draw an energy level diagram for the combustion of methanol.

4. a) The flow chart below outlines some of the process involved during extraction of copper from copper pyrites. Study it and answer the questions that follow.

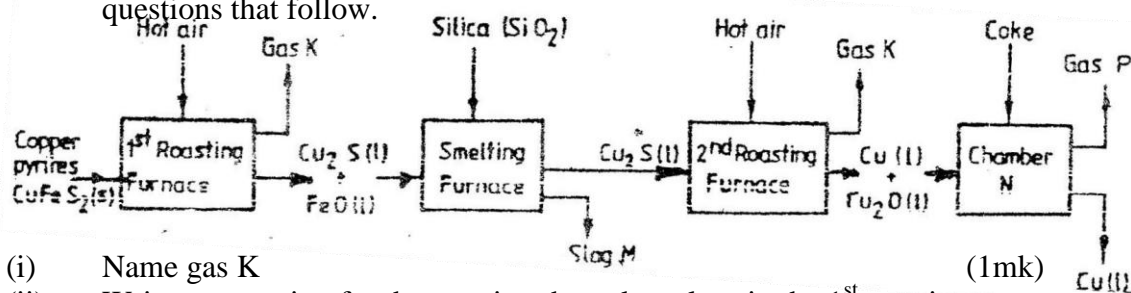

- Name gas K (1mk)
- Write an equation for the reaction that takes place in the 1st roasting furnace. (1mk)
- Write the formula of the cation present in slag M (1mk)
- Identify gas p (1mk)

- (v) What name is given to the reaction that takes place in chamber N? Give a reason for the answer. (1mk)
- (b) The copper obtained from chamber N is not pure. Draw a labeled diagram to show the set up you would use to refine the copper by electrolysis. (3mks)
- (c) Given that the mass of copper obtained from above extraction was 210kg, determine the percentage purity of the ore(copper pyrites) if 810kg of it was fed to the 1st roasting furnace. (Cu = 63.5, Fe = 56.0, s=32.0) (3mks)
- (d) Give two effects that this process could have on the environment (2mks)
5. The flow charts below show an analysis of a mixture R that contains two salts. Study the analysis and answer the questions that follow.

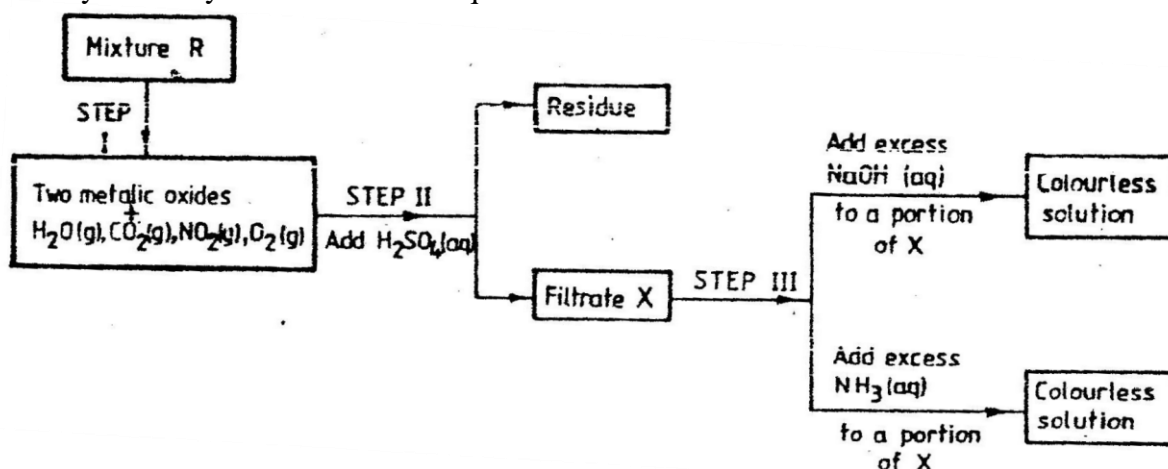

- (a) (i) What condition is necessary for the process in step I to take place? (1mk)
- (ii) Draw a labeled diagram for the set-up that could be used to separate the mixture formed in step II (2mks)
- (iii) Write ionic equation for the reaction between the cation in filtrate X and aqueous ammonia. (1mk)
- (iv) What observation would indicate the presence of $\text{NO}_2(\text{g})$ in step I (1mk)
- (v) State how water vapour, in step I could be identified. (1mk)

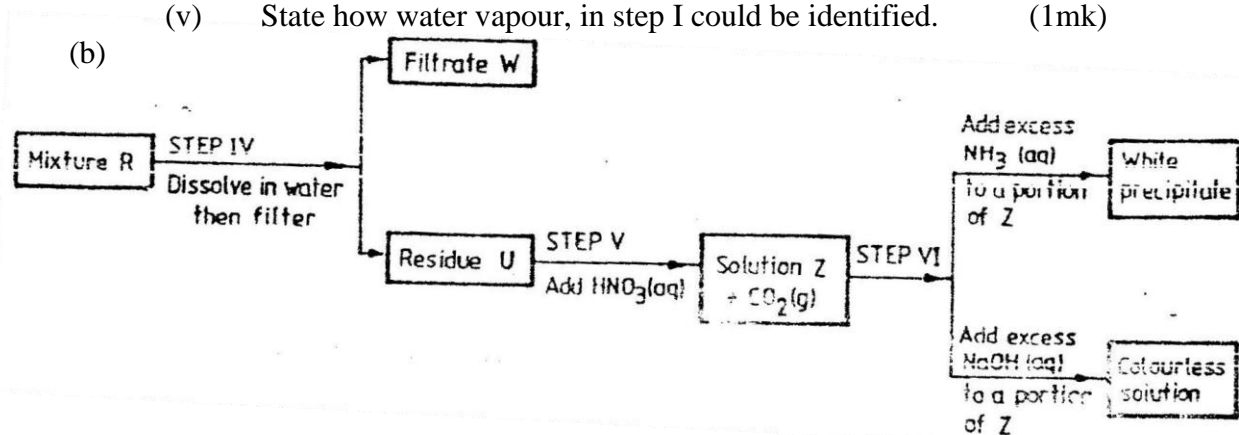

- (i) What conclusion can be drawn from step iV only? Explain? (2mks)
- (ii) Write the formula of an anion present in the residue U. Explain (2mks)
- (iii) Suggest the identity of the cation present in solution z. (1mk)
- (c) Name the two salts present in the mixture R. (2mks)

6. (a) The table below gives information about the major constituents of crude oil. Study it and answer the questions that follow.

Constituent	Boiling point ($^{\circ}\text{C}$)
Gases	Below 40
Petrol	40-175
Kerosene	175-250
Diesel oil	250-350
Lubricating oil	350-400
Bitumen.	Above 400

- (i) Which one of the constituents of crude oil has molecules with the highest number of carbon atoms? (2mks)
- (ii) Name the process you would use to separate a mixture of petrol and diesel and explain how the separation takes place. (2mks)
- (iii) Explain why the constituent of crude oil and write its formula (1mk)
- (iv) Name one gas that is likely to be a constituent of crude oil and write its formula. (1mk)
- (b) What condition could cause a poisonous gas to be formed when Kerosene is burnt? Explain (2mks)
- (c) Give one use of bitumen (1mk)

7. (a) The diagram below shows a set-up that can be used to obtain nitrogen gas in an experiment.

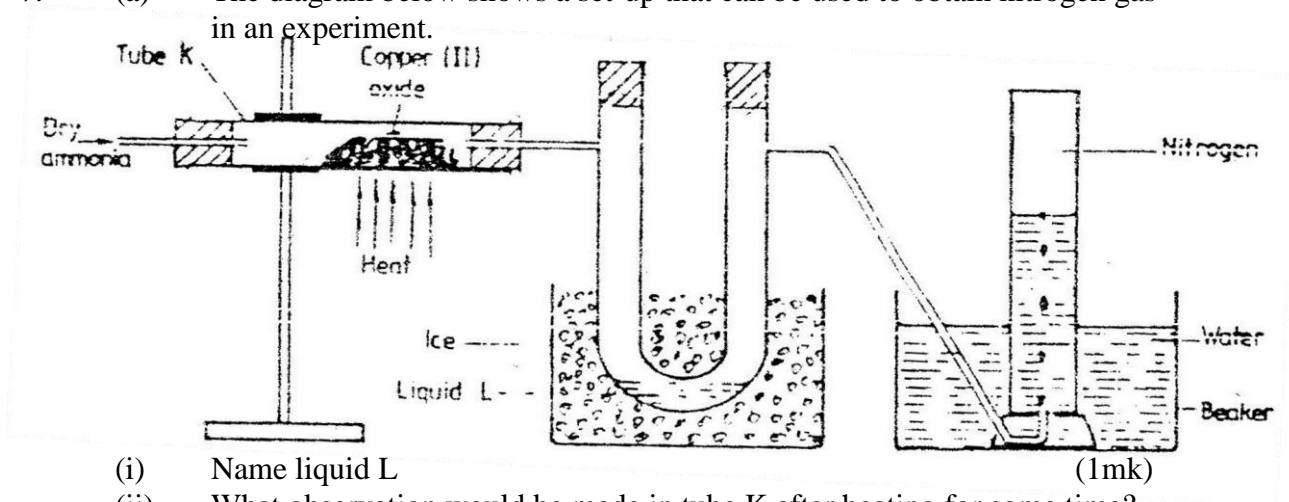

- (i) Name liquid L (1mk)
- (ii) What observation would be made in tube K after heating for some time? (1mk)
- (iii) Write an equation for the reaction that took place in tube K. (1 mk) (iv)
- If 320 cm^3 of ammonia gas reacted completely with the copper?
Calculate:
- I Volume of nitrogen gas produced. (1mk)
- II the mass of copper oxide that reacted (3mks)
(Cu = 63.5, O=16.0, one mole of gas occupies 24 liters at room temperature and pressure)
- (v) At the end of experiment the PH of the water in the beaker was found to be about

1) Explain

(2mks)

- (b) In another experiment a gas jar containing ammonia was inverted over a burning splint. What observation would be made? (1mk)
- (c) Why is it advisable to obtain nitrogen from air instead ammonia? (1mk)

KCSE 1996 CHEMISTRY PAPER 233/1

QUESTIONS

1. In an experiment to study the diffusion of gases, a student set up the apparatus shown in diagram 1. After sometime the student noticed a change in the water level as shown in the diagram

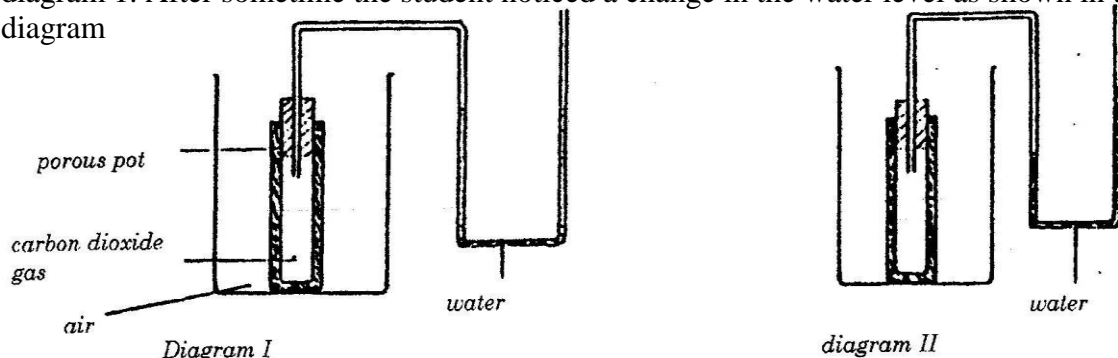

Give an explanation for the change in water level

(2mks)

2. A fixed mass of a gas has a volume of 250cm^3 at a temperature of 27°C and 750mm Hg pressure. Calculate the volume the gas would occupy at 42°C (2mks)

3. Zinc metal and hydrochloric acid reacts according to the following equation



1.96 g of zinc were reacted with 100cm^3 of 0.2M hydrochloric acid

(a) Determine the reagent that was in excess

(b) Calculate the total volume of hydrogen gas was liberated S.T.P

(Zn = 65.4 Molar gas volume = 22.4 litres at S.T.P

(1mk)

4. Ammonia can be converted to nitrogen monoxide as shown in the equation below

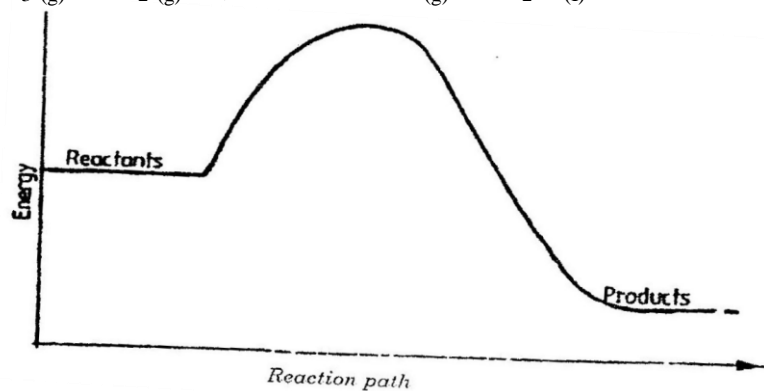
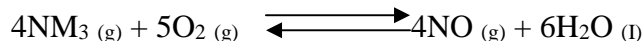

(a) Explain how an increase in temperature would affect the yield of nitrogen monoxide (2mks)

(b) On the energy level diagram above sketch, the energy level diagram that would be obtained if the reaction is carried out in the presence of platinum catalyst. (1 mk)

5. a) Using dots(.) and crosses (x) to represent electrons draw diagram to represent the bonding in:

(i) NH_3

(ii) NH_4^+

(1mk)

b) State why an ammonia molecule (NH_3) can combine with H^+ to form NH_4^+

(Atomic numbers: N=7 and H=1)

(1mk)

6. The table below shows some properties of substances E, F, G and H

Substance	Action with water	Melting point	Thermal conductivity
E	Un reactive	High	Poor
F	Reactive	High	Poor
G	Unreactive	High	Good
H	Unreactive	Low	Good

Select the substance that would be most suitable

- a) For making a cooking pot (1mk)
- b) As a thermal insulator (1 mk)
7. The reaction of propane with chlorine gas gave a compound of formula C₃H₇Cl.
- a) What condition is necessary for the above reaction to take place? (1mk)
- b) Draw two structural formulae of the compound C₃H₇Cl (2mks)
8. A sample of air contaminated with carbon monoxide and sulphur dioxide was passed through the apparatus shown in the diagram below.

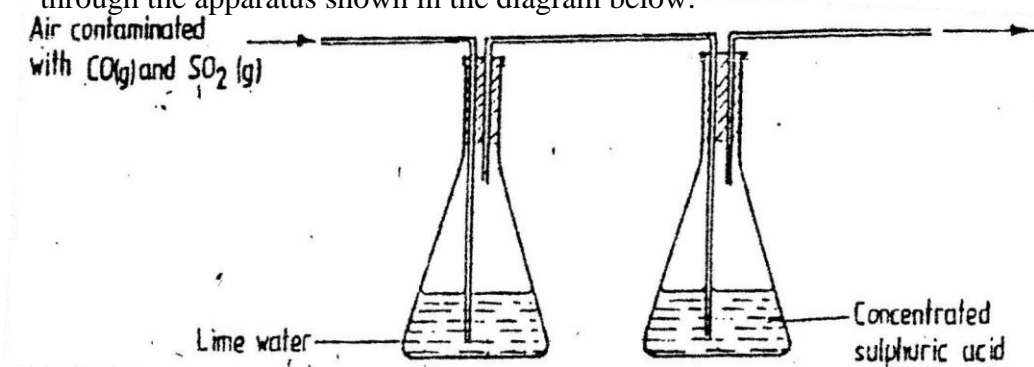

Which contaminant was removed by passing the contaminated air through the apparatus
Explain. (2mks)

9. Explain how a sample of CH₃CH₂CH₂OH, could be distinguished from a sample of CH₃COOH by means of a chemical reaction (2mks)
10. a compound whose structure is shown below is found in a detergent.



With reference to the structure, explain how the detergent removes grease during washing. (2mks)

11. Complete the table below.

Species	Number of neutrons	Electrons
H		

12. When magnesium metal is burnt in air, it reacts with both oxygen and nitrogen gases giving a white ash. Write two equations for the reactions that take place. (2mks)

13. Methane reacts with oxygen as shown by the equations I and II below:

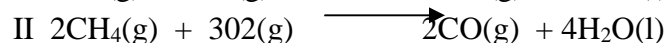
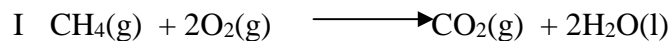

Which one of the two reactions represents the complete combustion of methane? Explain (2mks)

14. The decomposition of calcium carbonate can be represented by the equation:



Explain how an increase in pressure would affect the equilibrium position (2mks)

15. The table below gives the atomic numbers of elements **W**, **X**, **Y**, and **Z**. The letters do not represent the actual symbols of the elements.

Element	W	X	Y	Z
Atomic Number	9	10	11	12

a) Which one of the elements is least reactive? Explain (1mk)

b) i) Which two elements would react most vigorously with each other? (1mk)

ii) Give the formula of the compound formed when the elements in b(i) react (1mk)

16. On strong heating, sodium nitrate oxygen gas. In the spaces provided below, draw a labeled diagram of a set-up that could be used for heating sodium nitrate and collecting the oxygen gas liberated. (3mks)

17. Oxygen reacts with the elements phosphorous, sulphur and chlorine to form oxides of sulphur and its highest oxidation number. Complete the table for phosphorus and chlorine. (Atomic numbers: P=15, S= 16 Cl = 17)

Element	Oxide	Highest oxidation number
P	_____	_____
S	SO ₃	46
Cl	_____	_____

18. Explain why it is not advisable to use aqueous chloride solution as the salt bridge in the electrochemical cell formed between half cells, $\text{Pb}^{2+}(\text{aq})/\text{pb}(\text{s})$ $E^0 = 0.13\text{V}$ and

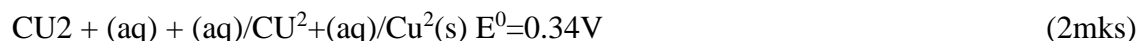

19. Use the information below to answer the questions that follow:

Equation Enthalpy of formation

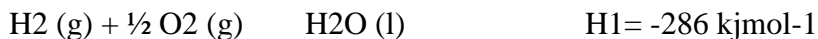

a) Define the term “enthalpy of formation of a compound (1mk)

- b) Calculate the molar enthalpy of combustion, ΔH_c^\ominus of ethanol:
 $C_2H_5OH(l) + 3O_2(g) \rightarrow 2CO_2(g) + 3H_2O(l)$ (2mks)

20. Complete the diagram below to show how α and β particles from a radioactive source can be distinguished from each other. Label your diagram clearly (3mks)

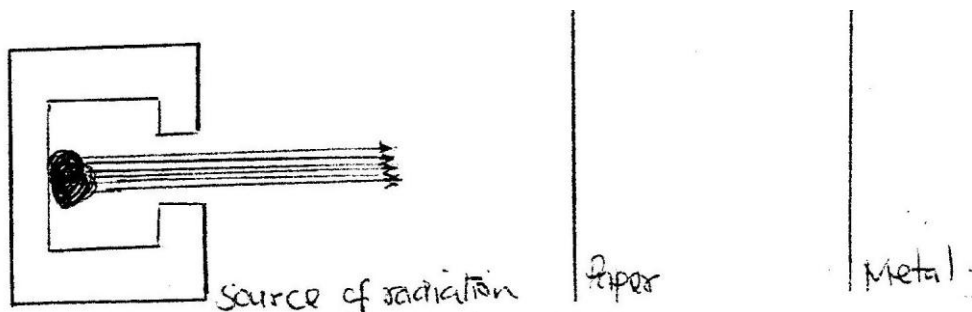

21. Chlorine and iodine are elements in the same group in the periodic table. Chlorine gas is yellow green, iodine; $I_2(aq)$ is brown.
- a) What observation would be made if chlorine gas is bubbled through aqueous sodium iodide? Explain using an ionic equation. (2mks)
- b) Under certain conditions chlorine and iodine react to give iodine chloride, $ICl_3(s)$. What type of bonding would you expect to exist in iodine trichloride? Explain (1mk)

22. The diagram below represents a set-up that was used to react lithium with water study it and answer the questions that follow:

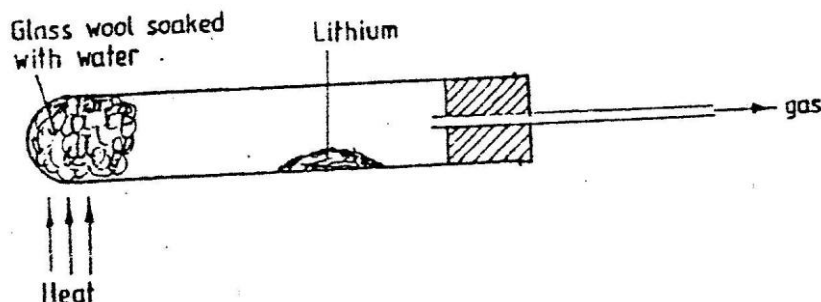

- a) Write an equation for the reaction that takes place; given that the atomic number of lithium is 3. (1mk)
- b) Why would it not be advisable to use potassium in place of lithium in the above set-up? (1mk)
23. Explain how you would obtain solid carbonate from a mixture of lead carbonate and sodium carbonate powders. (3mks)
24. In an experiment, 2.4g of sulphur was obtained by reacting hydrogen sulphide and chlorine as shown by the equation below:



- (a) Which of the reactants acts as a reducing agent in the above reaction? Explain.

(1mk)

- (b) Given that the yield of sulphur in the above reaction is 75%, calculate the number of moles of $\text{H}_2\text{S}_{(g)}$ used in the reaction (S=32.0) 25. A polymer has the following structure:

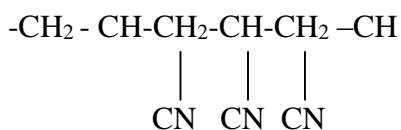

A sample of this polymer is found to have a molecular mass of 5194. Determine the number of monomers on the polymer (H=1.0, C= 12.0, N = 14.0)

26. Study the chart below and answer the questions that follow:

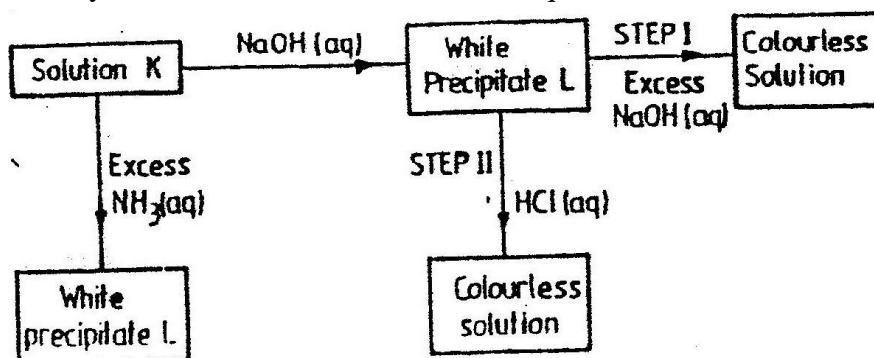

- a) Identify i) The metal ions in solution K (1mks)
 ii) The white precipitate L (1mk)
27. Study the flow chart below and answer the questions that follow

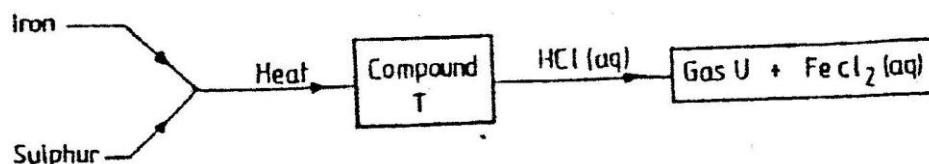

- a) Name i) Compound T (1mk) ii) Gas U (1mk) b) Give a chemical test that you could use to identify gas U (1mk)
28. A mixture of pentane and pentanoic acid was shaken with 0.1M sodium hydroxide solution and let to separate as shown in the diagram below:

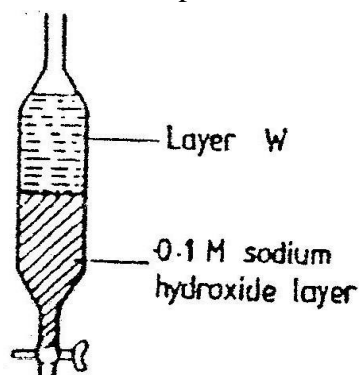

Name the main component in layer W. Give a reason for the answer (2mks)

29. Write an equation for the reaction that takes place when carbon monoxide gas is passed over heated lead (II) oxide. (1mks)

K.C.S.E 1996 CHEMISTRY PAPER 233/2

QUESTIONS

1. Sodium thiosulphate solution reacts with dilute hydrochloric acid according to the following equation.



In an experiment to study how the rate of reaction varies with concentration, 10cm³ of 0.4M sodium thiosulphate was mixed with 10cm³ of 2M hydrochloric acid in a flask. The flask was placed in a white paper marked with a cross X. The time taken for the cross X to become invisible when viewed from above was noted and recorded in the table below. The experiment was repeated three times as the temperature using the volumes in the table and the results recorded as shown in the table below.

Experiment	Volume of 0.4M thiosulphate (cm ³)	Volume of water (cm ³)	Volume of 2M HCl(cm ³)	Time (Sec)
1	10	0	10	16
2	7.5	2.5	10	23
3	5.0	5.0	10	32
4	2.5	7.5	10	72

- a) i) On the grid below, plot a graph of the volume of thiosulphate (Vertical axis) against time taken for the cross (X) to become invisible
- ii) From the graph determine how long it would take for the cross to become invisible if the experiment was done. (3mks)
- i) Using 6cm³ of the 0.4M thiosulphate (1mk) ii) Using 6cm³ of 0.2M thiosulphate solution (1mk)
- b) i) Using values for experiment I. Calculate
- i) Moles of thiosulphate used (1mk)
- ii) Moles of hydrochloric acid used (1mk) ii)
- Explain which of the two reactants in experiment I controlled the rate of the reaction? Explain (1mk)
- c) Give two precautions which should be taken in experiment I controlled the rate of the reaction? Explain (2mk)

2. a) The diagram below shows incomplete set – up of the laboratory and preparation collection of chlorine gas. Study it and answer the questions that follow.

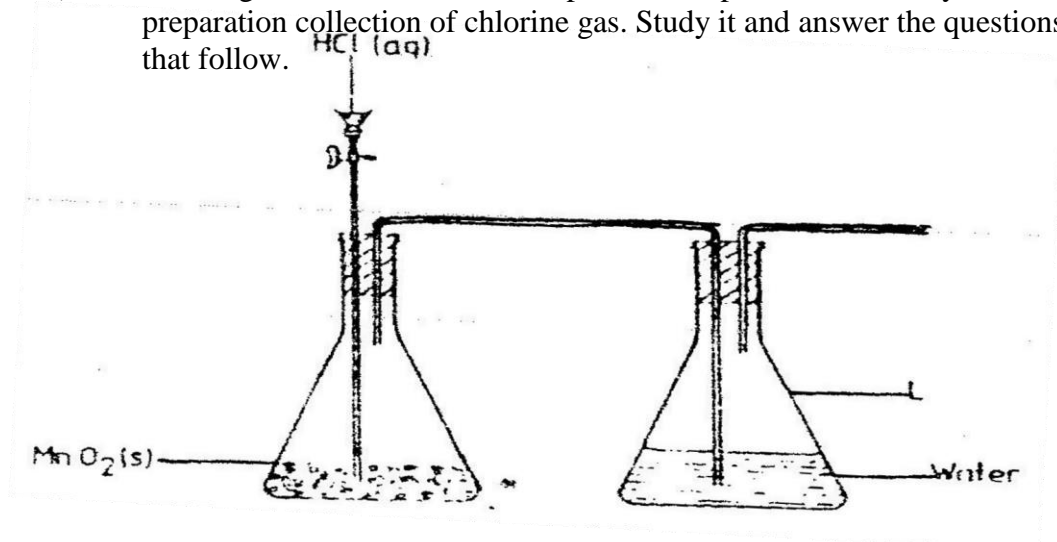

- i) Complete the set – up to show how dry chloride gas may be collected.
 ii) The equation for the redox reaction that takes place is



Explain, using oxidation numbers, which species is reduced (2mks)

- iii) What is the purpose of water in flask L? (1mk) b)

Study the diagram below and answer the questions that follow.

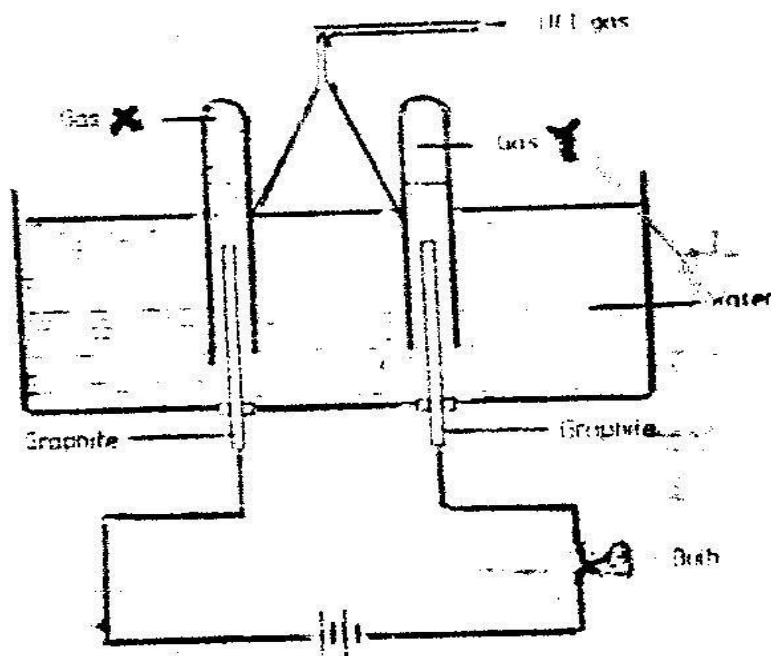

When some hydrogen chlorides gas is allowed into water and the mixture stirred, the bulb lights and gases X and Y are formed.

- i) Name: Gas X
 Gas Y
 ii) Explain why the bulb does not light before the hydrogen chloride gas is let into water. (2mks)
 iii) Explain using equations why the volume of gas X is less than that of gas (2mks)

3. The extraction of aluminium from its ore takes place in two stages, purification stage and electrolysis stage. The diagram below shows the set-up for the electrolysis stage.

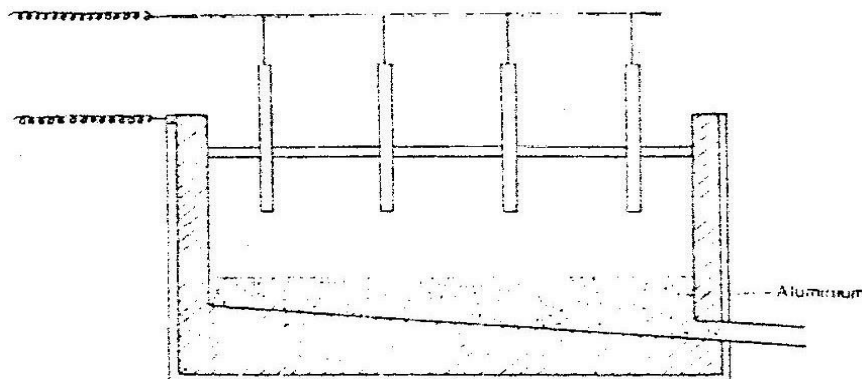

- a) i) Name the ore from which aluminium is extracted. (1mk)
 ii) Name one impurity, which is removed at the purification stage. (1mk)
- b) i) Label on the diagram each of the following
 i) Anode
 ii) Cathode
 iii) Region containing the electrolyte.
- ii) The melting point of aluminium oxide is 2054°C , but electrolysis is carried out between $800 - 900^{\circ}\text{C}$.
 i) Why is the electrolysis not carried out at 2054°C ? (1mk)
 ii) What is done at lower temperatures? (1mk)
 iii) The aluminium which is produced is tapped off as a liquid. What does this suggest about its melting point? (1mk)
- c) A typical electrolysis cell uses a current of 40,000 amperes. Calculate the mass (in kilograms) of aluminium produced in one hour. (3mks)
4. Study the table below and answer the questions that follow:

Element	Atomic number	Relative atomic mass	Melting point ($^{\circ}\text{C}$)
Aluminium	13	27.0	40.0
Calcium	20	12.0	850
Carbon		1.0	3730
Hydrogen		24.3	-259
Magnesium	12		650
Neon	10	31.0	-249
Phosphorous	15	23	44.2 (white)
Sodium			590 (red)

- a) Complete the table by filling in the missing atomic numbers and atomic masses. (2mks)
 b) Write the electron arrangement for the following ions (2mks)



- c) What is the melting point of hydrogen in degrees Kelvin? (1mk)
- d) Which of the allotropes of phosphorous has a higher density? Explain (2mks)
- e) The mass numbers of three isotopes of magnesium are 24, 25 and 26.
What is the mass number of the most abundant isotope of magnesium? Explain (2mks)
- f) Give the formula of the compound formed between aluminium and carbon. (1mk)
- g) Explain the difference in the melting points of magnesium and sodium. (2mks)

5. a) Study the table below and answer the questions that follow.

Compound	Melting point(°C)	Boiling point (°C)
C ₂ H ₄ O ₂	16.6	118
C ₃ H ₆ C ₃ H ₈ O	-185	-47.7
C ₅ H ₁₂	-127	97.2 36.3
C ₆ H ₁₄	-130	68.7
	-95.3	

- i) Which of the compounds is a solid at 10.0°C? Explain (1mk) ii)
Choose two compounds which are members of the same homologous series and explain the difference in their melting points. (3mks)
- iii) The compound C₃H₈O is an alcohol. How does its solubility in water differ from the solubility of C₅H₁₂ in water? Explain. (2mks)
- b) Complete combustion of one mole of a hydrocarbon produced four moles of carbon dioxide and four moles of water only.
- i) Write formula of the hydrocarbon (1mk)
- ii) Write the equation for the combustion reaction: (1mk)
- c) In a reaction, an alcohol J was converted to a hex-1-ene.
- i) Give the structural formula of the alcohol J
- ii) Name the reagent and conditions necessary for the reaction in c (i) above
- d) Compound K reacts with sodium hydroxide as shown below? (1mk)

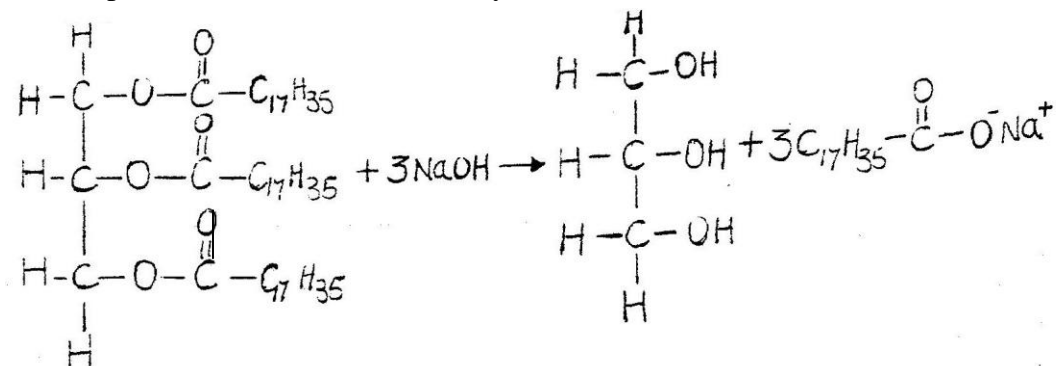

i) What type of reaction is represented by the equation above? (1mk) ii)

To what class of organic compounds does K belong? (1mk) 6. a)

Give the name of each of the processes described below which takes place when salts are exposed to air for sometime.

i) Anhydrous copper sulphate becomes wet (1mk) ii) Magnesium chloride forms an aqueous solution (1mk) iii) Fresh crystals of sodium carbonate, $\text{Na}_2\text{CO}_3 \cdot 10\text{H}_2\text{O}$ (1mk)

b) Write the formula of the complex ion formed in each of the reactions described below.

(i) Zinc metal dissolves in hot alkaline solution (1mk)

(ii) Copper hydroxide dissolves in excess ammonia solution. (1 mk)

(c) A hydrated salt has the following composition by mass. Iron 20.2% Oxygen 23.0%, sulphur 11.5%, water 45.3 %. Its relative formula mass is 278.

(i) Determine the formula of the hydrated salt.. (3mks)

(Fe=56, S=32; O = 16, H =1)

(ii) 6.95gm of the hydrates salt were dissolved in distilled water and the total volume made to 250 cm^3 of solution. Calculate the concentration of the salt solution in moles per litre.

7. (a) The graph below shows the solubility of sulphur dioxide gas at different

temperatures. Use the following in it to answer the questions that follow.

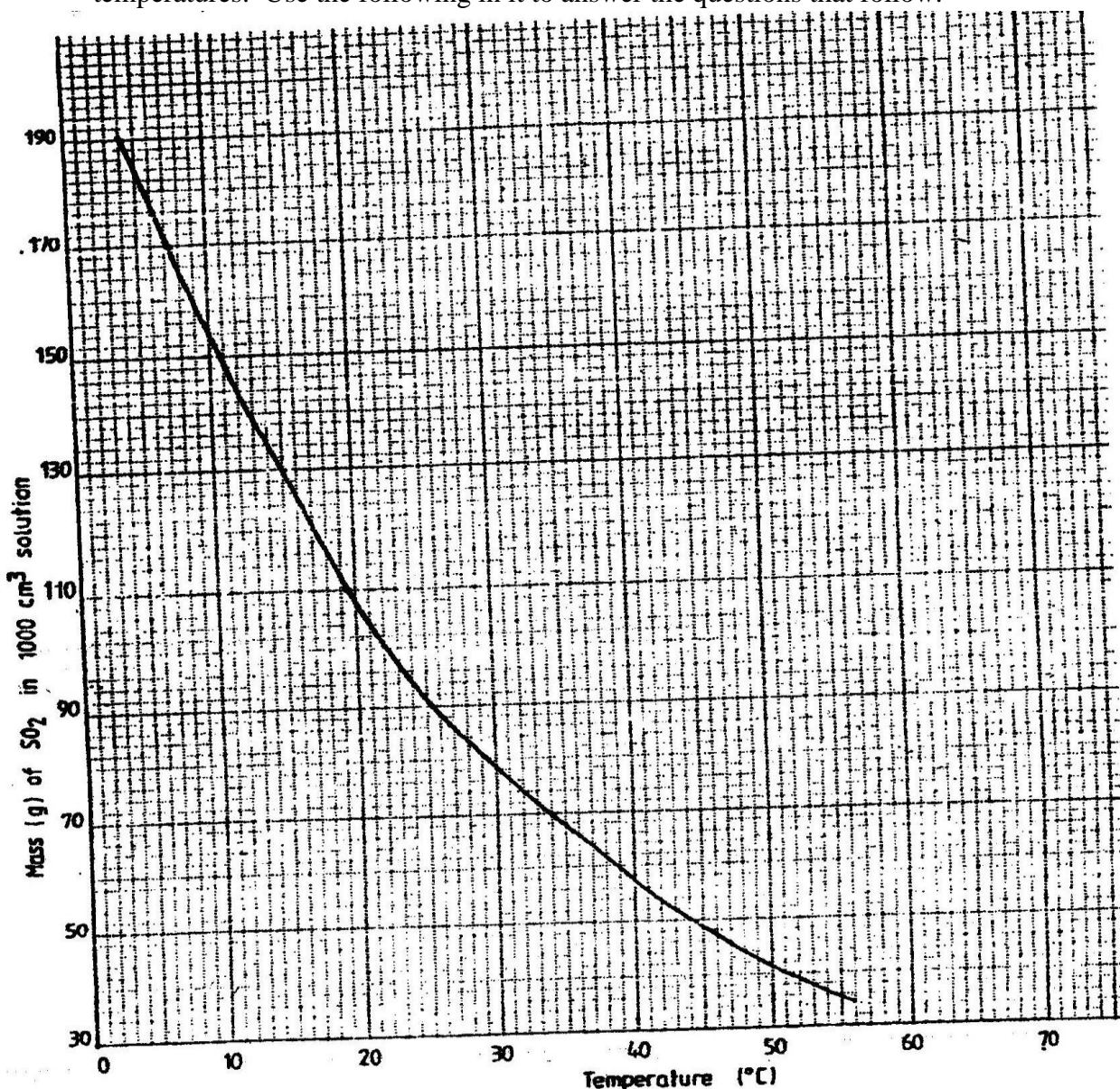

- (i) From the graph determine:
- I The lowest temperature at which 1,000cm³ of solution would contain 116g of sulphur dioxide.
 - II The maximum mass of sulphur dioxide that would dissolve in 15 litres of solution at 10⁰C
- (ii) Sodium hydroxide reacts with sulphur trioxide according to the following equation.
- $$2\text{NaOH}(\text{aq}) + \text{SO}_2(\text{g}) \longrightarrow \text{Na}_2\text{SO}_3(\text{aq}) + \text{H}_2\text{O}(\text{l})$$
- Using the information in the graph determine the volume of 2M sodium hydroxide required to completely neutralize one litre of saturated sulphur dioxide solution 23⁰C. (S=32.0; O = 16.0) (3mks)

Study the flow chart below and answer the questions that follow.

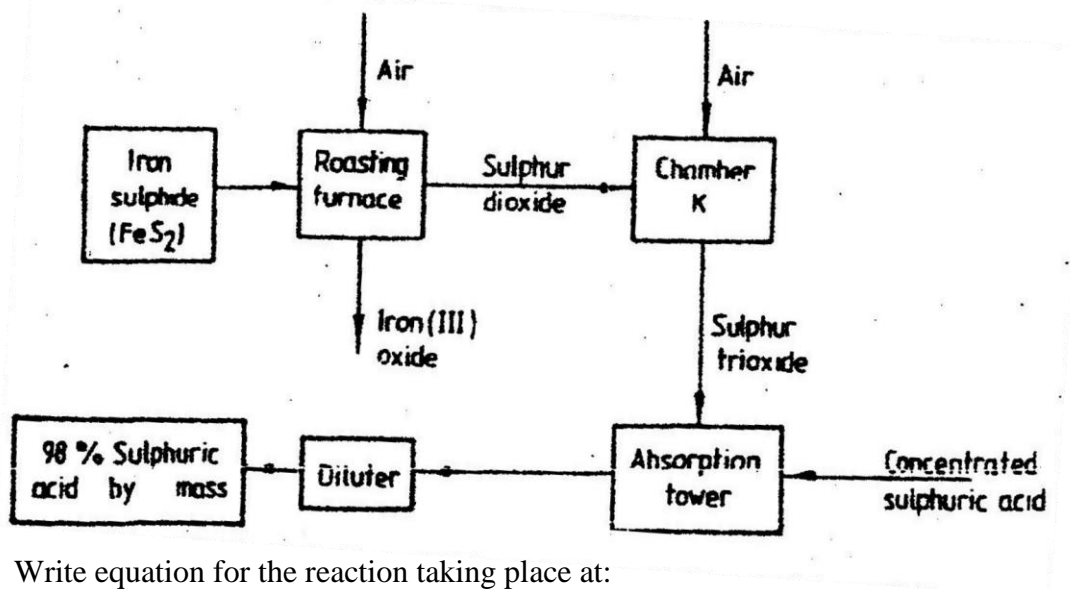

Write equation for the reaction taking place at:

I The roasting furnace (1mk)

II The absorption tower (1mk)

III The diluter (1mk)

(ii) The reaction taking place in chamber K is

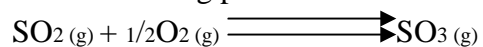

- I Explain why it is necessary to use excess air in chamber K
 II Name another substance used in chamber K
 (c) Study the scheme given below and answer the questions that follow:

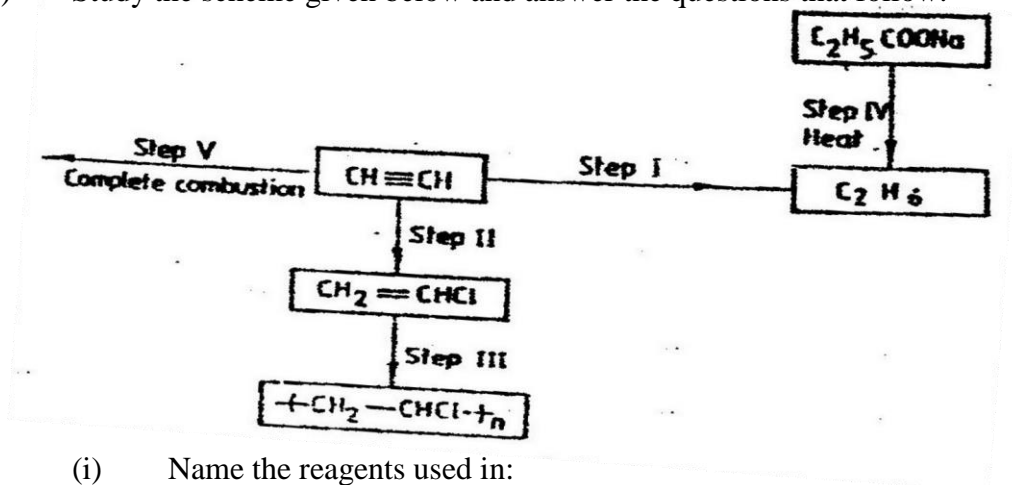

- (i) Name the reagents used in:
 Step I..... (1mk)
 Step II..... (1mk)
 Step IV..... (1mk)
- (ii) Write an equation for the complete combustion of $\text{CH}=\text{CH}$ (1mk)
 Explain one disadvantage of the continued use of items made from the compound formed in step III (2mks)

CHEMISTRY PAPER 233/1 K.C.S.E 1997 QUESTIONS.

1. The set – up below was used to study some properties of air.

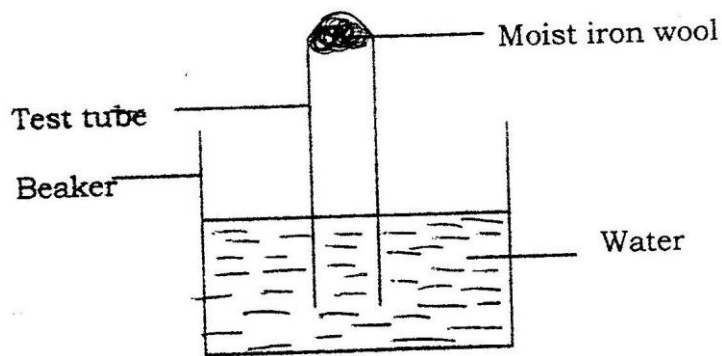

- State and explain two observations that would be made at the end of the experiment.
2. When extinguishing a fire caused by burning kerosene, carbon dioxide is used in preference to water .Explain
3. Complete the table below by inserting the missing information in the space provided.

Name of polymer	Name of monomer	One use of the polymer
	Vinyl chloride (Chloroethane)	

4. When dilute nitric acid was added to a sample of solid C, a colourless gas that formed a white precipitate with limewater was produced. When another sample of solid C was heated strongly in a dry test – tube, there was no observable change.

5. The structure shown below represent two cleansing agents, A and B

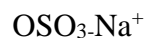
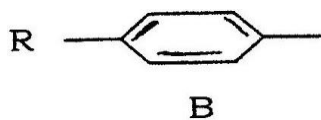

Which cleansing agent would be more suitable for washing in water containing magnesium sulphate?

Give a reason

6. Study the set – up below and answer the questions that follow.

Diagram

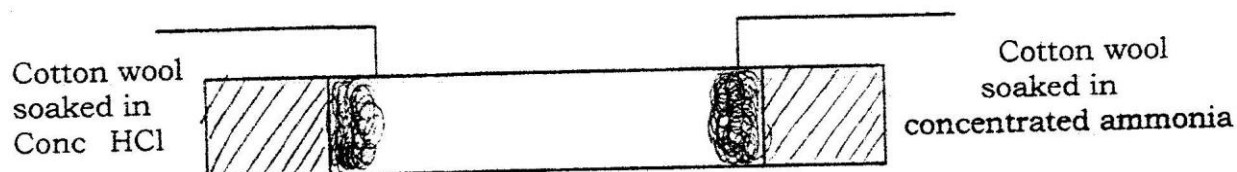

- What observation would be made in the tube?
- Indicate with across (x) on the diagram the likely position where the observation stated in (a) above would be made.

NB. Not to touch the cotton wool.

7. M grammes of a radioactive isotope decayed to 5 grammes in 100 days.

The Half – life of the isotope is 25 days.

- What is meant by half – life?
 - Calculate the initial mass of M of the radioactive isotope.
8. The empirical formula of a hydrocarbon is C₂H₃. The hydrocarbon has a relative molecular mass of 54. (H = 1.0, C = 12.0).
- C₂H₃
 - Draw the structural formula of the hydrocarbon
 - To which homologous series does the hydrocarbon drawn in (b) above belong?

9. Potassium sulphite solution was prepared and divided into two portions. The first portion gave a white precipitate when reacted with barium nitrate. On addition of dilute hydrochloric acid the white precipitate disappeared.

- Write the formula of the compound which formed as the white precipitate.
- Write the equation for the reaction between dilute hydrochloric acid and the compound whose formula is written in (a) above.
- What observation would be made if one drop of potassium dichromate solution was added to the second portion followed by dilute hydrochloric

acid?

10. 0.63g of lead powder were dissolved in excess nitric acid to form lead nitrate solution. All the lead nitrate solution was reacted with sodium sulphate solution. a) Write an ionic equation for the reaction between lead nitrate and sodium sulphate solutions.
b) Determine the mass of the lead salt formed in (a) above.
(Pb = 207, S = 32.0, O = 16)
11. Explain why anhydrous magnesium chloride is fairly soluble in organic solvents while anhydrous magnesium chloride is insoluble.
12. Name and draw the structure of the compound formed when methane reacts with excess chlorine in the presence of U.V light.
13. Sulphur burns in air to form sulphur dioxide. A simple energy level diagram for the reaction is given below. Study the diagram and answer the questions that follow.

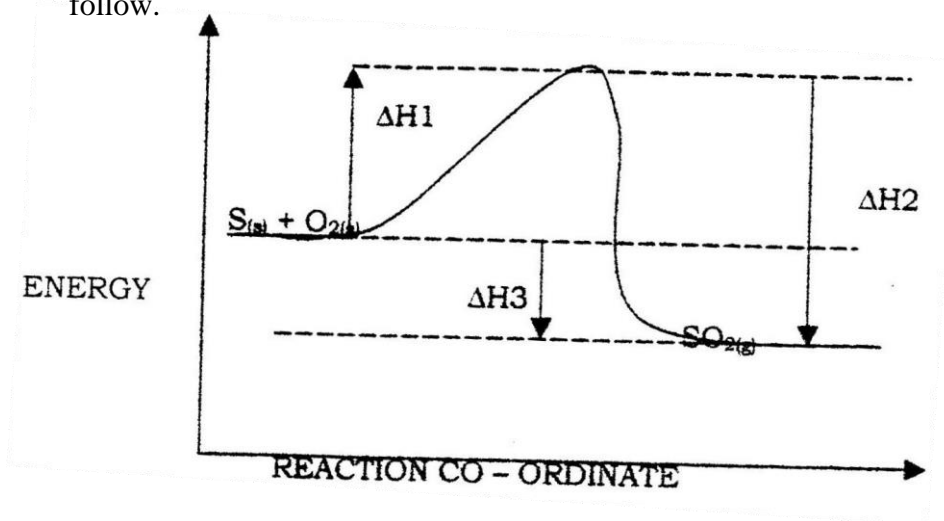

- a) What do the following represent?
b) Write an expression, for ΔH_3 in terms of ΔH_1 and ΔH_2
14. In an experiment, chlorine gas was passed into moist hydrogen sulphide contained in a boiling tube as shown in the diagram

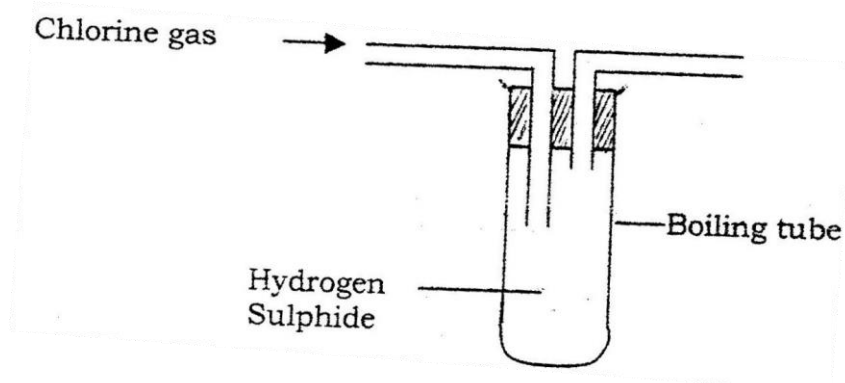

- What observation was made in the boiling tube?
- Write an equation for the above reaction.
- What precaution should be taken in carrying out this experiment? Give a reason.

15. Complete the diagram below to show how a sample of aqueous ammonia can be prepared in the laboratory.

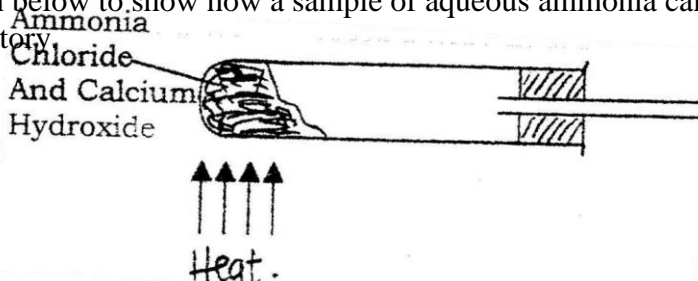

- A gas occupies a volume of 400cm^3 at 500K and 1 atmosphere pressure. What will be the temperature of the gas when the volume and pressure of the gas is 100cm^3 and 0.5 atmospheres respectively.
- In an equation below, identify the reagent that acts as a base. Give a reason.

$$\text{H}_2\text{O}_{(\text{aq})} + \text{H}_2\text{O}_{(\text{l})} \longrightarrow \text{H}_3\text{O}_{(\text{aq})}^+ + \text{HO}_{(\text{aq})}^{2-}$$
- Study the scheme below and answer the questions that follow.

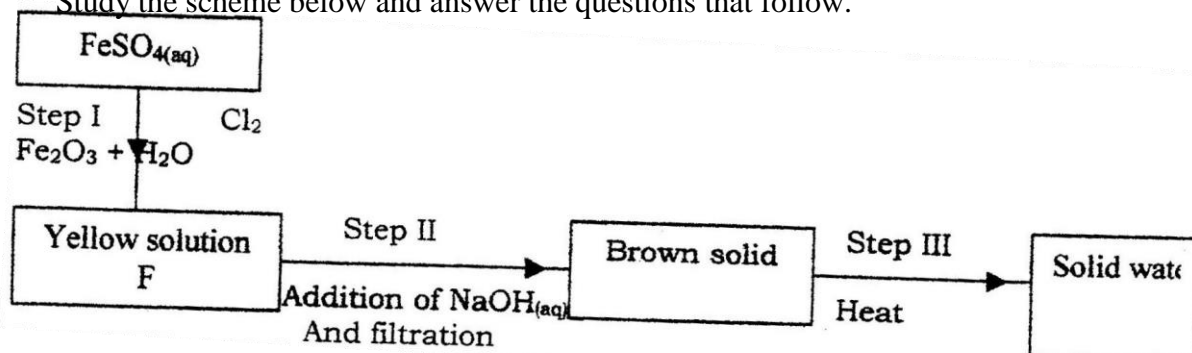

- Write the formula of the cation present in solution F.
 - What property of chlorine is shown in step I?
 - Write an equation for the reaction which occurs in step III.
19. 90cm^3 of 0.01M calcium hydroxide were added to a sample of water containing 0.001 moles of calcium hydrogencarbonate.

- a) Write an equation for the reaction which took place
- b) Calculate the number of moles of calcium ions in 90cm³ of 0.01M calcium hydroxide.
- c) What would be observed if soap solution was added drop wise to a sample of the water after the addition of calcium hydroxide? Give a reason.
20. When 0.6g of element J were completely burnt in oxygen and all the heat evolved was used to heat 500cm³ of water, the temperature of the water rose from 23°C to 32°C. Calculate the relative atomic mass of element J given that the specific heat capacity of water = 4.2JK⁻¹_{g-1}, density of water = 1.0g/cm³ and molar heat of combustion of J is 380KJmol⁻¹
21. A student set up the experiment below to collect gas K the glass wool was heated before heating the Zinc powder.

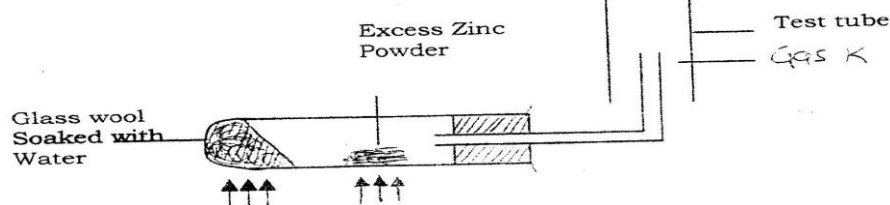

- Why was it necessary to heat the moist glass wool before heating zinc powder
22. In an experiment to separate a mixture of two organic liquids, liquid M (b.p 56°C) and liquid N (b.p. 118°C), a student set up the apparatus shown below.

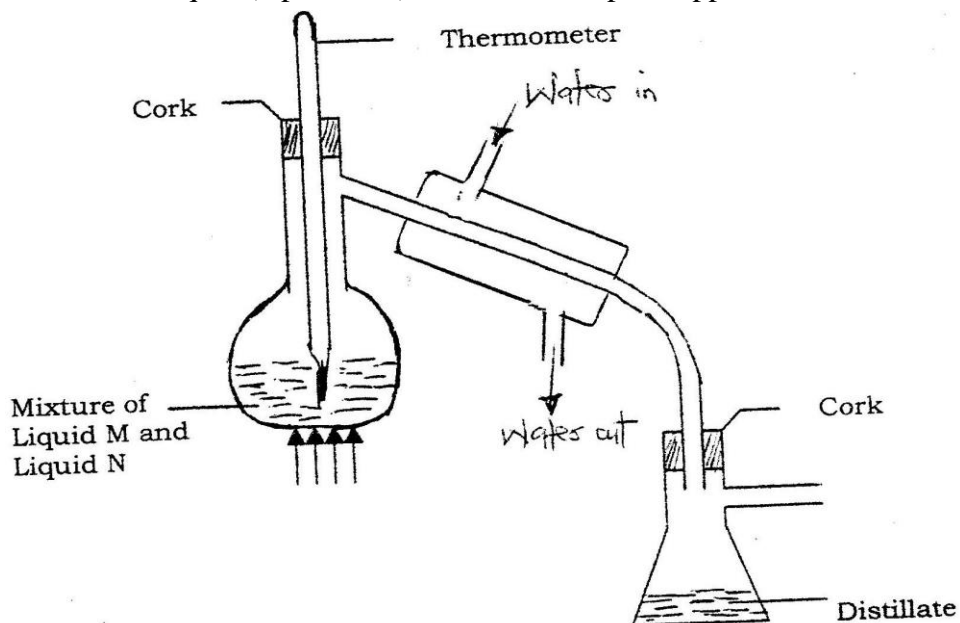

- a) Identify two mistakes in the set – up
- b) What method would the student use to test the purity of the distillates obtained?
23. An element Y has the electronic configuration 2.8.5
- a) Which period of the periodic table does the element belong?
- b) Write a formula of the most stable anion formed when element Y ionizes
- c) Explain the difference between the atomic radius of element Y and its ionic radius.
24. Aqueous potassium sulphate was electrolysed using platinum electrodes in a cell.
- a) Name the products formed at the cathode and anode.

Anode

- b) How does the concentration of the electrolyte change during electrolysis.
- c) Why would it not be advisable to electrolyse aqueous potassium sulphate using potassium metal electrodes.
25. The information below relates to element L, Q,R and T. The letters do not represent the actual symbols of the elements. Arrange the elements in

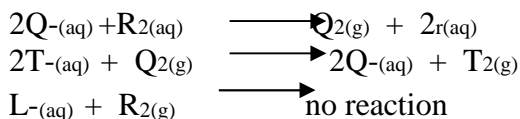

- a) Give the formula of an oxide which reacts with both dilute hydrochloric acid and hot concentrated sodium hydroxide.
- b) Give the formulae of the products formed when the oxide in (a) above reacts with excess hot concentrated sodium hydroxide.
26. Using dots (.) and crosses (x) to represent outermost electrons, draw diagrams to show the bonding in CO_2 and H_3O^+ (Atomic numbers; H = 1.0, C = 14.0, O = 8).
27. Calculate the mass of nitrogen dioxide gas that would occupy the same volume as 10g of hydrogen gas at same temperature and pressure. (H = 1.0, N = 14.0, O = 16.0)

CHEMISTRY PAPER 233/2 K.C.S.E 1997

QUESTIONS

1. Use standard electric potentials for elements A, B, C, D and F given below to answer the questions that follow.

E^{θ} (Volts)			
$A^{2+}(aq) + 2e$	\rightleftharpoons	A (s)	- 2.90
$B^{2+}(aq) + 2e$	\rightleftharpoons	B (s)	-2.38
$C^{+}(aq) + 2e$	\rightleftharpoons	C (g)	- 0.00
$D^{2+}(aq) + 2e$	\rightleftharpoons	D (s)	+ 0.34
$\frac{1}{2} F_2(g) + e$	\rightleftharpoons	F ⁻ (aq)	+2.87

- (i) Which element is likely to be hydrogen? Give a reason for your answer (ii) What is the E^{θ} value of the strongest reducing agent?
- (iii) In the space provided draw a labeled diagram of the electrochemical cell that would be obtained when half – cells of elements B and D are combined
- (iv) Calculate the E^{θ} value of the electrochemical cell constructed in (iii) above

- (b) During the electrolysis of aqueous copper (II) sulphate using copper electrodes, a current of 0.2 amperes was passed through the cell for 5 hours
- Write an ionic equation for the reaction that took place at the anode
 - Determine the change in mass of the anode which occurred as a result of the electrolysis process
(Cu = 63.5, 1 Faraday = 96,500 coulombs.)

2. (a) Give the names of the following compounds

- $\text{CH}_3\text{CH}_2\text{CH}_2\text{CH}_2\text{OH}$
- $\text{CH}_3\text{CH}_2\text{COOH}$
- $\text{CH}_3\text{C-O-CH}_2\text{CH}_3$

(b) Study the information in the table below and answer the questions that follow

Number of carbon atoms per molecule	Relative molecular mass of hydrocarbon
2	28
3	42
4	56

- Write the general formula of the hydrocarbon in the table
 - Predict the relative atomic mass of the hydrocarbon with 5 carbon atoms
 - Determine the molecular formula of the hydrocarbon in (ii) above and draw its structural formula (H = 1.0 C = 12.0)
- (c) Study the scheme given above and answer the questions that follow

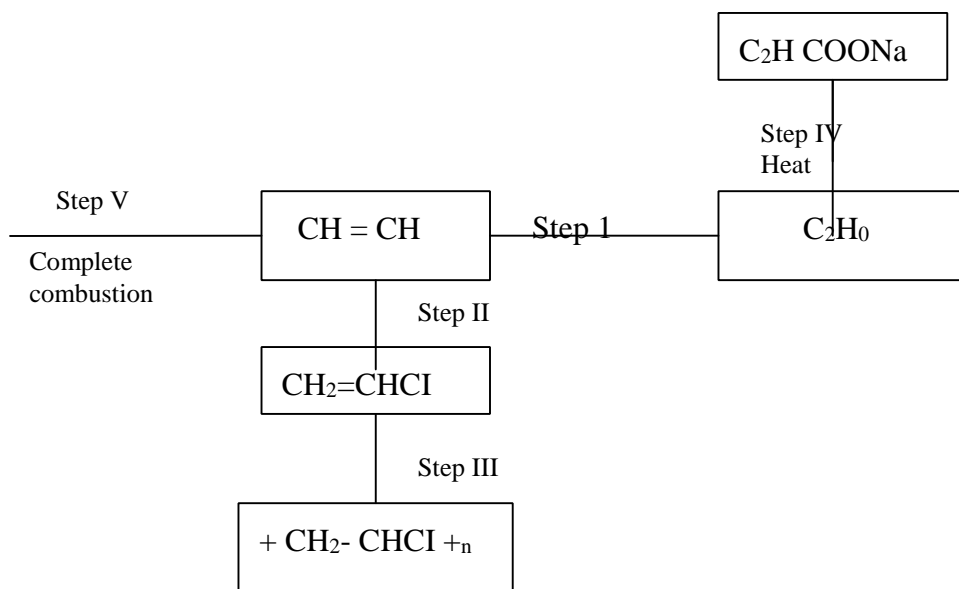

- Name the reagents used in:
 Step I Step
 II Step III

- (ii) Write an equation for the complete combustion of $\text{CH}=\text{CH}$
- (iii) Explain one disadvantage of the continued use of items made from the compound formed in step III

3. (a) Study the information below and answer the questions that follow:

The letters do not represent the actual symbols of the elements

Element	Atomic Number	Melting Point Element	Formula of Chloride	Melting Point Chloride
G	11	98	GCl	801
H	12	650	HCl ₂	715
J	14	1410	JCl ₄	-70
K	16	113	K ₂ Cl ₂	-80
L	20	851	LCl ₂	780

- (i) Which elements are metals? Give a reason
- (ii) Write the formula of the compound formed when element H reacts with elements K
- (iii) Explain why the melting point of J is higher than that of K
- (iv) What is the oxidation state of J in its chloride (v) How does the:
- I – Melting point of fluoride of G compare with that of its chloride?
- II- Reactivity of H and L with water compare? Give an explanation
(2mks)

4. (a) The diagram below shows the extraction of sodium metal using the Downs cell. Study it and answer the questions that follow

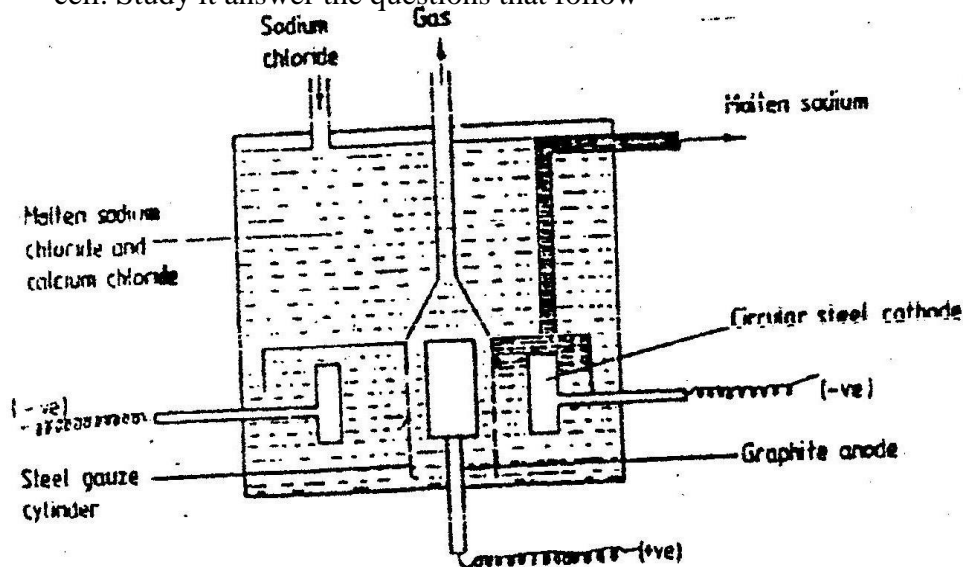

- (i) Explain why in this process the sodium chloride is mixed with calcium chloride.
 - (ii) Why is the anode made of graphite and not steel?
 - (iii) State two properties of sodium metal that make it possible for it to be collected as shown in the diagram
 - (iv) What is the function of the steel gauze cylinder?
 - (v) Write ionic equations for the reactions which take place at:
 - I Cathode
 - II Anode
 - (vi) Give one industrial use of sodium metal
 - (b) Explain why the sodium metal is kept stored under kerosene
5. The reaction between and methanoic acid at 30⁰ C proceeds according to the information given below



Concentration of Br ₂ (aq) Moldm ⁻³	Time minutes
10.0 x 10 ⁻³	0
8.1 x 10 ⁻³ 6.6 x 10 ⁻³	1
10 ⁻³ 4.4 x 10 ⁻³	2
3.0 x 10 ⁻³ 2.0 x 10 ⁻³	4
10 ⁻³	6
1.3 x 10 ⁻³	8
	10

- (a) On the grid below, plot a graph of concentration of Bromine (Vertical axis against time)
- (b) From the graph determine:
 - (i) The concentration of bromine at the end of 3 minutes

- (ii) The rate of reaction at time 't' where $t = 1\frac{1}{2}$ minutes
- (c) Explain how the concentration of bromine affects the rate of reaction
- (d) On the same axis sketch the curve that would be obtained if the reaction was carried out at 20°C and label the curve as curve II. Give a reason for your answer.
6. (a) The diagram below represents a set up that was used to obtain dry nitrogen from air.

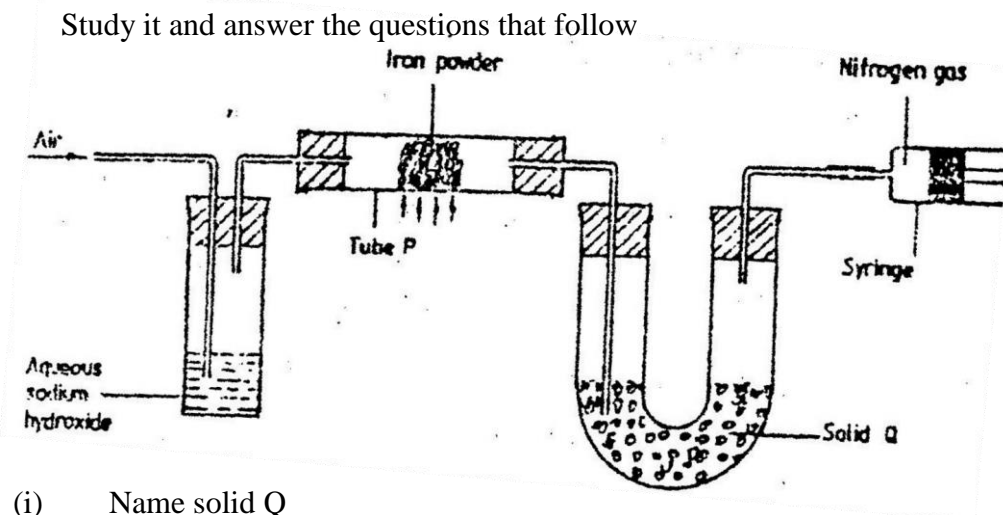

- (i) Name solid Q
- (ii) What is the purpose of sodium hydroxide?
- (iii) Write an equation for the reaction which took place in tube P
Give the name of one impurity present in the nitrogen gas obtained
- (iv) Give a reason why liquid nitrogen is used for storage of semen for artificial insemination
- (b) The set up below was used to prepare nitric acid

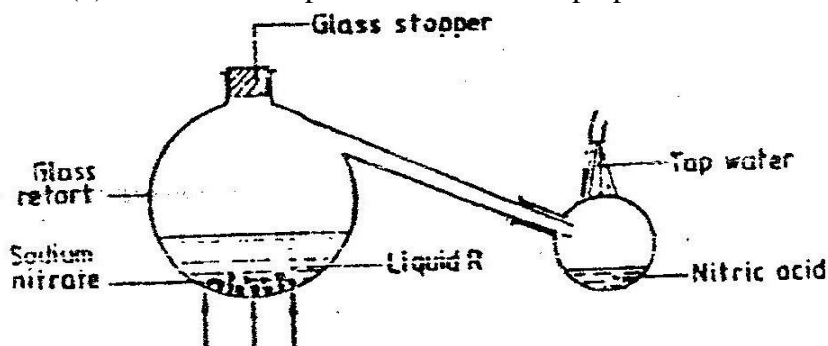

- (i) Give the name of liquid R
- (ii) Write an equation for the reaction which took place in the glass retort
- (iii) Explain the following
- Nitric acid is stored in dark bottles
 - The reaction between copper metal with 50% nitric acid (one volume of acid added to an equal volume of water) in an open test tube gives brown fumes.

- (c) A factory uses nitric acid and ammonia gas as the only reactants for the preparation of fertilizer. If the daily production of the fertilizer is 4800 kg calculate the mass of ammonia gas used daily.

7. (a) In an experiment, dry hydrogen chloride gas was passed through heated zinc turnings as shown in the diagram below. The gas produced was then passed through heated lead (II) oxide.

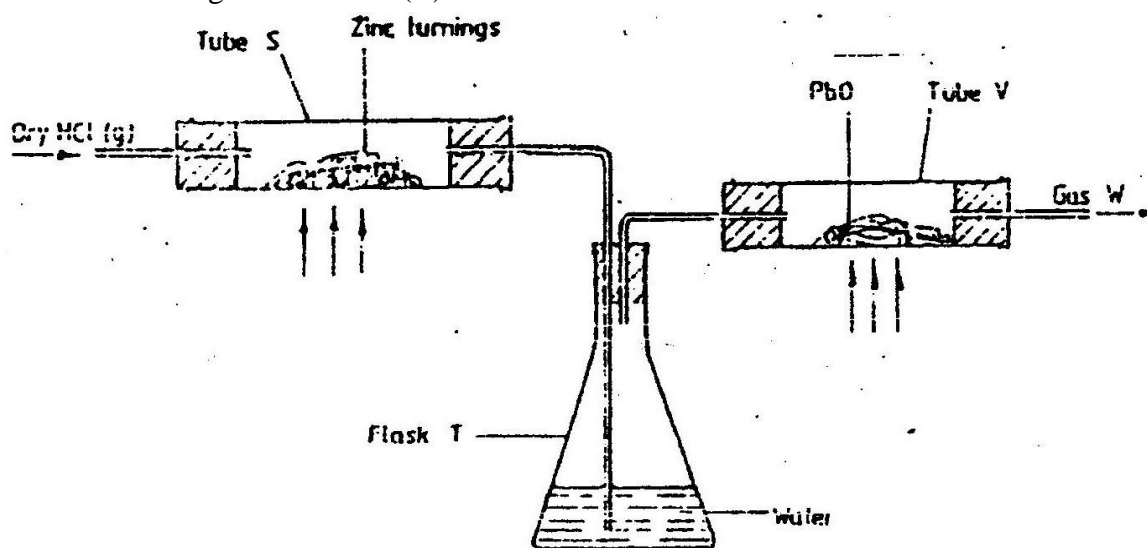

- (i) What is the function of water in the flask?
Write equations for the reactions that took place in the tubes
S
V
- (ii) How would the total mass of tube V and its contents compare before after the experiment? Explain
- (b) Chloride can be prepared by using the following three agents; solid sodium chloride, concentrated sulphuric acid and potassium permanganate (i) What is the role of each of the following in the reaction?
I Concentrated sulphuric acid
II potassium permanganate
(ii) Name the bleaching agent formed when chlorine gas is passed through cold dilute sodium hydroxide solution
(iii) Name one other use of the compound formed in (ii) above other than bleaching
- (c) 1.9 gm of magnesium chloride was dissolved in distilled water. Silver nitrate solution was added until in excess. Calculate the mass of silver nitrate that was used for the complete reaction. Relative molecular mass of magnesium chloride = 95, N = 14.0, O = 16.0, Ag = 108.0

CHEMISTRY PAPER 233/ 1 K.C.S.E 1998

QUESTIONS

2. An isotope of Uranium ^{234}U , decays by emission of an alpha particle to thorium
92
a) Write the equation for the nuclear reaction undergone by isotope.

- b) Explain why it is not safe to store radioactive substances in containers made from aluminium sheets.
3. Study the information in the table and answer the question below the table.

Substance	Solubility g /100g water
A	1.26×10^2
B	1.09×10^2

Describe how a solid sample of substance A could be obtained from a solid mixture of A and B.

4. Give one advantage and one disadvantage of using petrol containing tetraethyl lead in motor vehicles.
5. Use the information below to answer the questions that follow:
- | | | | | | |
|-----------------------|---|----|-------|----------------------|-----------|
| Zn ²⁺ (aq) | + | 2e | zn(s) | \rightleftharpoons | -0.76 |
| Al ³⁺ (aq) | + | 3e | Al | \rightleftharpoons | (s) -1.66 |
| Fe ²⁺ (aq) | + | 2e | Fe(s) | \rightleftharpoons | -0.44 |

- a). Calculate the E value for the electrochemical cell represented bellow.

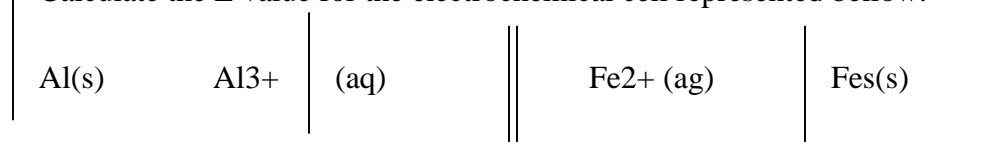

- a) Give a reason why aluminium metal would protect iron from rusting better than zinc metal.

6. The table below shows some properties of substances C,D and E. Study it and answer the questions that follow.

Substance	M.P (0C)	Solubility in water	Electrical solid state	Conductivity mol stated.
E	-39	Insoluble	Good	good
D	1610	Insoluble	Poor	poor
E	801	Soluble	Poor	good

Select substance

- a) Within a giant molecular structure
- b) That is not likely to be an element
7. On complete combustion of a sample of hydrocarbon, 3.52 gm of carbon dioxide and 1.44gm of water were formed. Determine the molecular formula of the hydrocarbon.

(Relative molecular masses of hydrocarbon =56, carbon dioxide 44, water = 18 and relative atomic masses H = 1.0 and c=12.0)

8. A sample of water drawn from a river passing through an agricultural district was divided into two portions. The first portion gave a white precipitate when acidified barium chloride was added. The second portion when warmed with aqueous sodium hydroxide gave a colourless gas, which turned a moist red litmus paper blue.

- (a) Identify the ions present in the river water.
(b) Suggest the possible sources of the ions identified in (a) above.

8. The equation below represents a redox reaction. Identify the reducing agent. Give a reason.
 $2\text{FeCl}_2(\text{aq}) + \text{Cl}_2(\text{g}) \longrightarrow 2\text{FeCl}_3(\text{aq})$

9. (a) What is meant by dynamic equilibrium?
(b) State and explain the observation that would be made if a few pellets of potassium hydroxide are added to the equilibrium mixture.

10. An ion of phosphorous can be represented as $^{31}_{15}\text{P}^{3-}$

15

Draw a diagram to show the distribution of the electrons and the composition of the nucleus of the ion of phosphorous.

11. Diamond and graphite are allotropes of carbon. In terms of structure and bonding explain the following.

- (a) Diamond is used in drilling through hard rocks
(b) Graphite is used as a lubricant

12. Distinguished between a strong and a weak acid. Give examples.

13. The set-up below was used to electrolyze aqueous copper (II) sulphate

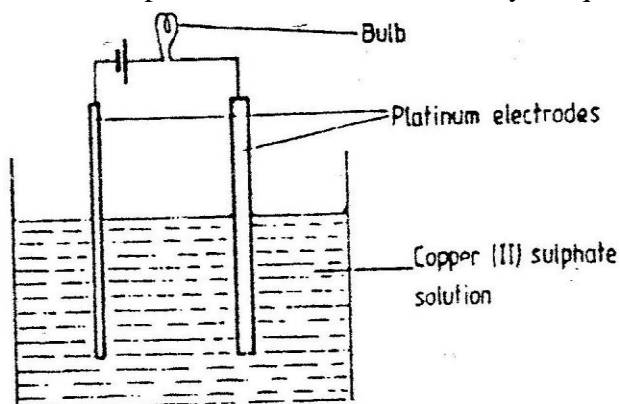

- a) Explain why the bulb light is brightly at the beginning of the experiment and becomes dim after sometime.
b) Write the ionic equation of the reaction that took place.

14. Draw the structural formula of:

- (a) Ethanol
(b) Propanoic
(c) Give the name of the organic compound formed when ethanol and propanoic acid react in the presence of concentrated sulphuric acid.



In one process, 680 kg of ammonia were reacted with excess carbon dioxide. Calculate the mass of urea that was formed. (H = 1.0, C = 12.0, N = 14.0, O = 16.0 and relative molecular mass of ammonia = 17)

Calculate the mass of Urea that was formed

19. Describe how a solid sample of lead (II) Chloride can be prepared using the following reagents, dilute nitric acid, dilute hydrochloric acid and lead carbonate.
20. The diagram below represents a charcoal burner. Study it and answer the questions that follow

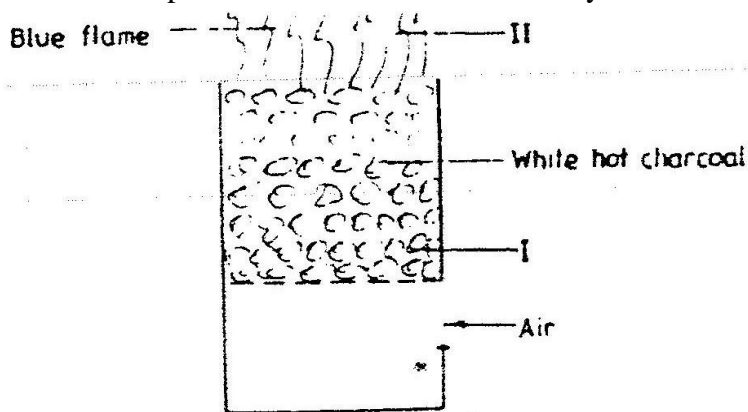

Write equations for the reactions taking place at I and I and II

21. The formula given below represents a portion of a polymer Give:

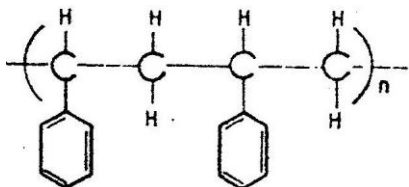

- a) The name of the polymer.
- b) One disadvantage of continued use of this polymer.
22. The scheme below shows some reaction sequence starting with solid N.

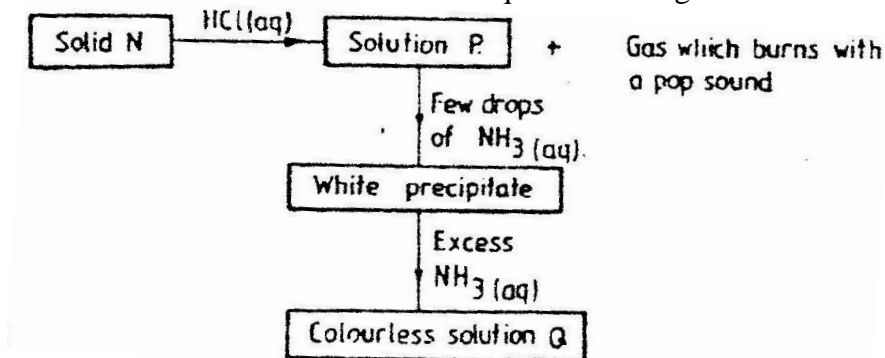

- a) Identify solid N
- b) Write the formula of the complex ion present in solution

23. A sealed glass tube containing air at s.t.p was immersed in water at 100°C. Assuming that there was no increase in the volume of the glass tube due to the expansion of the glass, calculate the pressure of the inside tube. (standard pressure = 760mmHg,)
24. A beekeeper found that when stung by a bee, application of a little solution of hydrogen carbonate helped to relieve the irritation from the affected area. Explain.
25. The diagram below shows the physical state of matter. Study it and answer the questions that follow.

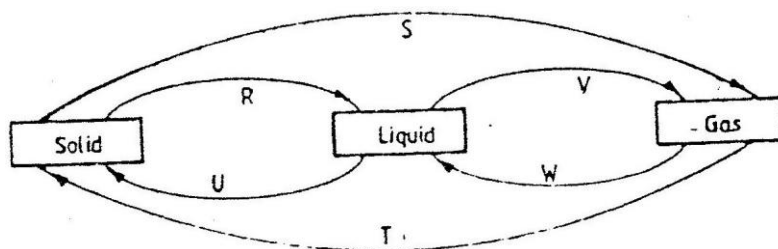

Identify the processes R, V, w and U

- (c) Name one substance which can undergo the process represented by S and T.
26. The table below gives the energy required to remove the outermost electron for some group I elements.

Element	I	II	III	IV
Energy kJmol ⁻¹	494	418	519	376

Arrange the elements in order of their reactivity starting with the most reactive.

27. A hydrocarbon slowly decolorizes bromine gas in the presence of sunlight but does not decolourise acidified potassium permanganate
Name and draw the structural formula of the fourth member of the series to which the hydrocarbon belongs.
28. The column below was used do soften hard water

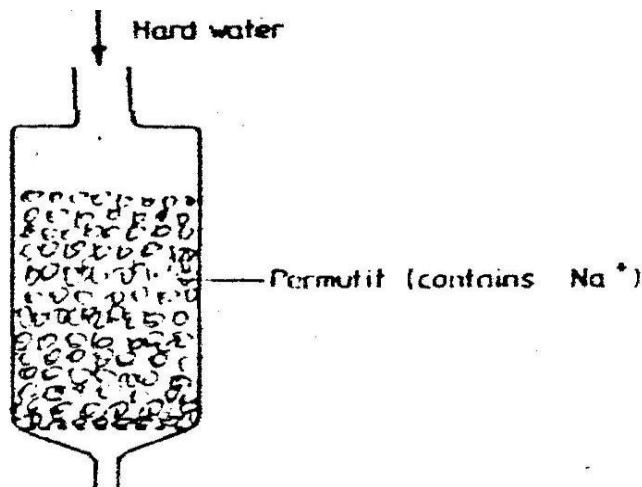

- (i) Explain how the hard water was softened as it passed through the column (ii) After some time the material in the column is not able to soften hard water How can the material be activated?

- (iii) Give one advantage of using hard water for domestic purposes.
29. What is the oxidation number of chlorine in CO_4

CHEMISTRY PAPER 233/2 K.C.S.E – 1998

QUESTIONS

1. (a). An ore is suspected to contain mainly iron. Describe a method that can be used to confirm the presence of iron in the ore
- (b) Excess carbon monoxide gas was passed over a heated sample of an oxide of iron as shown in the diagram below. Study the diagram and the data below it to answer the questions that follow.

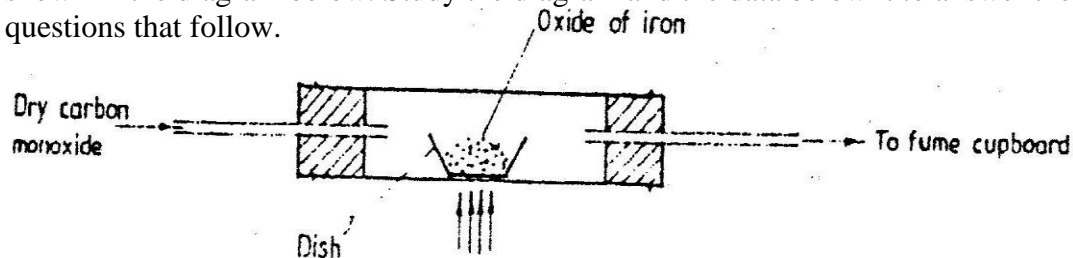

Mass of empty dish	=	10.98g
Mass of empty dish + oxide of iron	=	13.30g
Mass of empty dish + residue	=	12.66g

- (i) Determine the formula of the oxide of iron. (relative formula mass of oxide iron = 232, Fe = 56.0, O = 16.0)
- (ii) Write an equation for the reaction which took place in the dish
- (c) Corrosion is a destructive process in which iron which is converted into hydrated iron (III) oxide. State:
- (i) two conditions necessary for rusting to occur
- (ii) One method used to protect iron from rusting
- (d) Explain why it is not advisable to wash vehicles using seawater
2. (a) The following equations represent two different types of reactions
- (i) $n\text{C}_4\text{H}_8(\text{g}) \rightarrow (\text{C}_4\text{H}_8)_n(\text{s})$
- (ii) $\text{C}_2\text{H}_6(\text{g}) + \text{Cl}_2(\text{g}) \rightarrow \text{C}_2\text{H}_5\text{Cl}(\text{l}) + \text{HCl}(\text{g})$
State the type of reaction represented by:
- (i)
- (ii)
- (b) The fermentation of glucose produces ethanol as shown in the equation below $\text{C}_2\text{H}_{12}\text{O}_6(\text{aq}) \rightarrow 2\text{CH}_3\text{CH}_2\text{OH}(\text{aq}) + 2\text{CO}_2(\text{g})$
- (i) State how the concentration of ethanol produced could be increased
- (ii) State and explain the observation that would be made when a piece of sodium metal is added to a sample of ethanol contained in a beaker
- (iii) Give two commercial uses of ethanol other than in the manufacture of alcoholic drinks
- (c) The molecular formula of a hydrocarbon is C_6H_{14} . The hydrocarbon can be converted into two other hydrocarbons as shown by the equation below
- (i) Name and draw the possible structural formula of X

Name

Structural formula

- (ii) State and explain the observation that would be made if a few drops of bromide water were added to a sample of X.
- (iii) Write an equation for the complete combustion of C_3H_8

3. The flow chart below shows the industrial preparation of ammonia and the process used

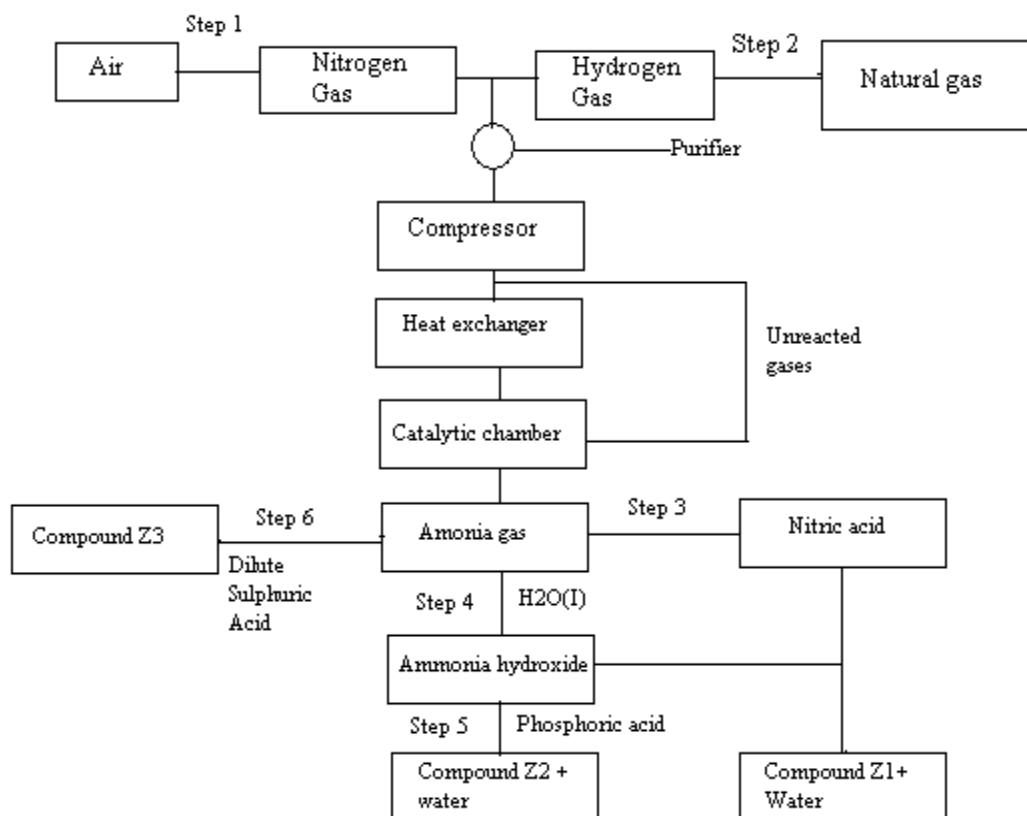

in the manufacture of some ammonium compounds. Study and answer the questions that follow

- (a) Give the name of the
- Process in step 1
 - Reaction that takes place in step 5
- (b) State one other source of hydrogen gas apart from natural gas
- (c) Explain why it is necessary to compress nitrogen and hydrogen in this process
- (d) Write an equation for the reaction which takes place in step 6
- (e) Name the catalyst and the reagents used in step 3
- Catalyst
- Reagent
- (f) Name compound Z1
- (g) Give one commercial use of compound Z2

4. The set – up below was used to prepare anhydrous chlorides of a number of elements in a laboratory where no fine cupboard was available. The chlorides were to be collected in

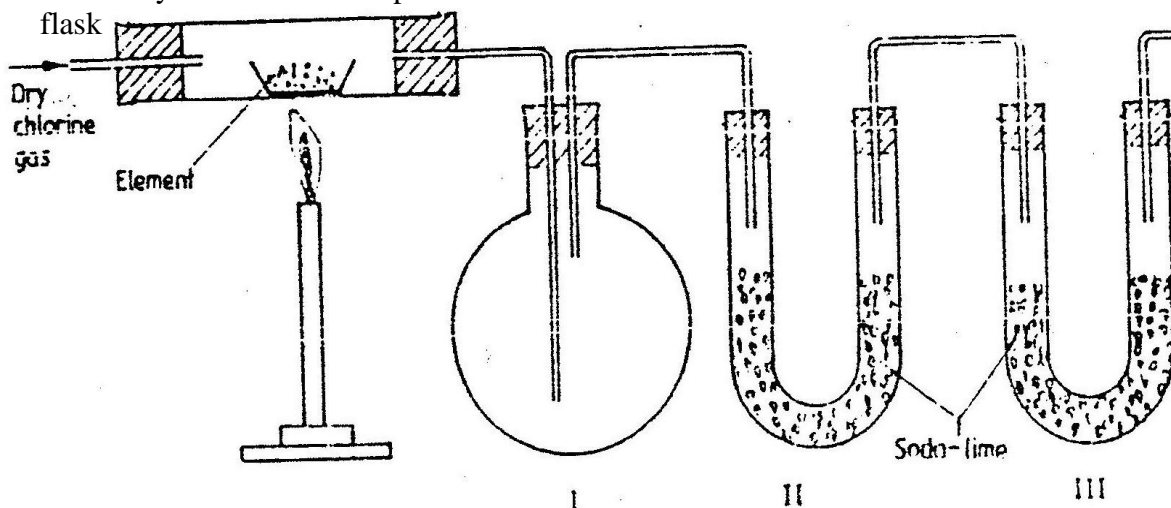

The following table shows the melting and boiling points of the chlorides that were prepared.

- Explain why it is necessary to pass dry chlorine through the apparatus before heating each element
 - Give two reasons why tubes II and III were filled with Soda lime (solid mixture of sodium hydroxide and calcium hydroxide)
 - Explain why it would not be possible to collect any sodium chloride in flask I
 - Name one other substance that can be used in tubes II and III
 - Write an equation for the reaction that forms phosphorous (III) chloride
 - Describe how you would separate a mixture of sodium chloride and aluminium chloride
1. (a) The table below gives the solubilities of hydrated copper (II) sulphate in mol dm³ at different temperatures

- (i) On the grid provided, plot a graph of solubility of copper (II) sulphate (vertical axis) against temperature.
- (ii) From the graph, determine the mass of copper (II) sulphate deposited when solution is cooled from 70°C to 40°C .

(Molar mass of hydrated copper (II) sulphate = 250g)

- (b) In an experiment to determine the solubility of sodium chloride, 5.0cm^3 of a saturated solution of sodium chloride weighing 5.35g were placed volumetric and diluted to a total volume of 250cm^3
- 25.0cm^3 of the dilute solution chloride completely reacted with 24cm^3 of 0.1M silver nitrate solution.

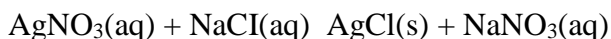

Calculate:

- (i) Moles of silver nitrate in 24cm^3 of solution
- (ii) Moles of sodium chloride in 25.0cm^3 of sodium
- (iii) Moles of sodium chloride in 250cm^3 of solution
- (iv) Mass of sodium chloride in 5.0cm^3 of saturated sodium chloride Solution (Na = 23.0, Cl = 35.5)
- (v) Mass of water in 5.0cm^3 of saturated solution of sodium chloride
- (vi) The solubility of sodium chloride in g/100 water
5. In order to determine the molar of neutralization of sodium hydroxide, 100cm^3 of 1M sodium hydroxide and 100cm^3 of 1 M hydrochloric acid both at the same initial temperature were mixed and stirred continuously with a thermometer. The thermometer of the resulting solution was recorded after every 30 seconds until the highest temperature of the solution was attained. Thereafter the temperature of the solution was recorded for a further two minutes
- (a) (i) Why was it necessary to stir the mixture of the two minutes
- (ii) Write an ionic equation for the reaction which took place
- (iii) The sketch below was obtained when the temperature of the mixture were plotted against time. Study and answer the questions that follow.

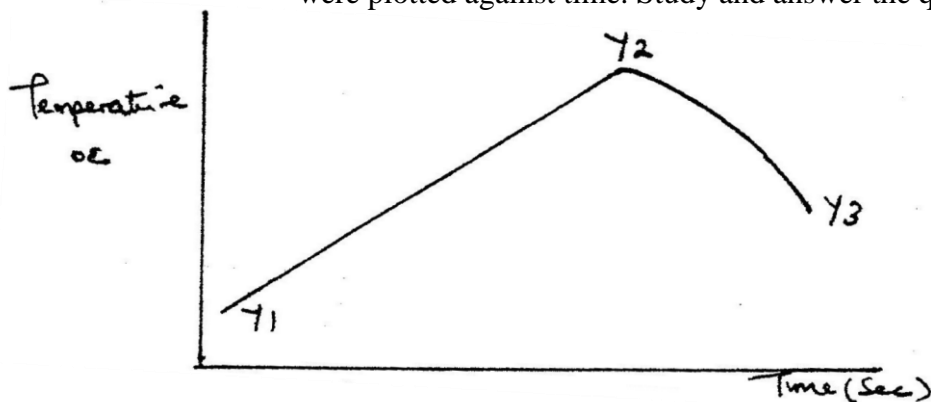

- I. What is the significance of point Y2?
- II. Explain why there is a temperature change between points Y1 and Y2
- Y3 and Y4
- (iv) In the initial temperature for both solutions was 24.5°C and the highest temperature attained by the mixture was 30.9°C Calculate the:

- I. heat change for the reaction
(specific heat capacity of the solution = $4.2\text{Jg}^{-1}\text{K}^{-1}$ and the density of the solution = 1.0g/cm^3)
- II. Molar heat of neutralization of sodium hydroxide

- (v) Explain how the value of the molar heat of neutralization obtained in this experiment would compare with the one that would be obtained if the experiment was repeated using 100cm^3 of 1 Methanoic acid instead of hydrochloric acid.
- (b) On the grid provided below, draw an energy level diagram for the reaction between hydrochloric acid and sodium hydroxide

6. Study the information given in the table below and answer the questions that follow. The letters do not represent the actual symbols of the elements

Element	Atomic number	Boiling point
S	3	1603
T	13	2743
U	16	718
V	18	87
W	19	1047

- (a) Select the elements which belong to the same
- Group
 - Period
- (b) Which element
- Is in gaseous state at room temperature? Explain
(Take room temperature to be 298K)
 - Does not form an oxide?
- (c) Write the
- Formula of the nitrate of element
 - Equation for the reaction between elements S and U
- (d) What type of bond would exist in the compound formed when U and T react?
Give a reason for your answer
- (e) The aqueous sulphate of element W was electrolyzed using inert electrodes Name the products formed at the:
- Cathode
 - Anode

CHEMISTRY PAPER 233/1 K.C.S.E 1999

QUESTIONS

- Aluminium metal is a good conductor and is used for overhead cables. State any other
- Study the flow chart below and answer the questions that follow

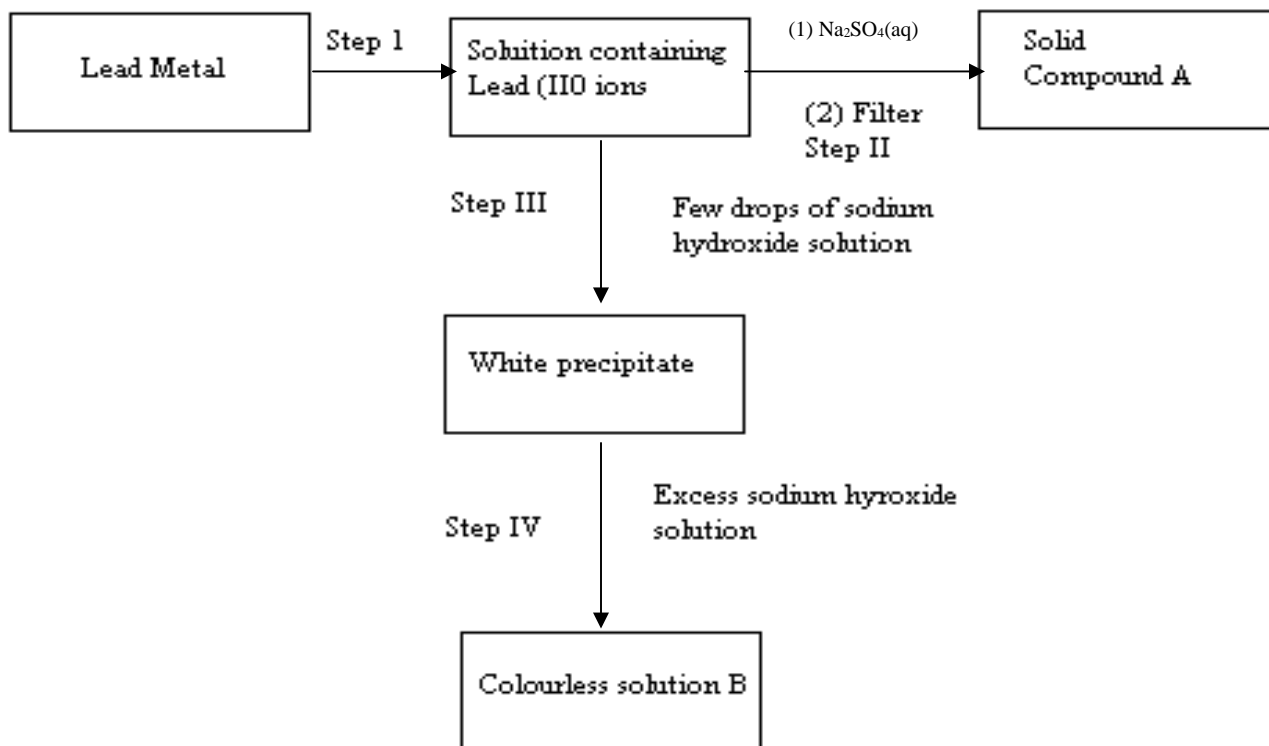

- Name:
two properties that make aluminium suitable for this use
 - The reagent used in step I
 - Compound A
- (b) Write an ionic equation for the reaction in step IV
- State and explain the observation that would be made when a few drops of concentrated sulphuric acid are added to a small sample of hydrated copper (II) sulphate
 - 4.76g of liquid ammonia and 4.76g of liquid nitrogen were each allowed to warm up and hang into gas at warm temperature and pressure. Relative atomic masses: H=1.0 and N=14.0. Using the data given above, explain which gas occupied the greater volume
 - Sulphur dioxide and nitrogen dioxide react as shown in the equation below
$$\text{SO}_2(\text{g}) + \text{NO}_2(\text{g}) \rightarrow \text{SO}_3(\text{g}) + \text{NO}(\text{g})$$
 - Using the oxidation numbers of either sulphur or nitrogen, show that this is a redox reaction
 - Identify the reducing agent
 - What type of bond is formed when lithium and Fluorine react? Explain

(Atomic numbers: Li = 3 and F = 9)

7. Write the formula of sulphide of an element C, whose atomic number is 5. (C is not the actual symbol of the element)
8. The table below shows the solubility of a salt at various temperatures

Temperature ($^{\circ}\text{C}$)	Solubility g/ 100g W _a
0	36
40	30
80	25
110	20

What would happen if a sample of a saturated solution of the salt at 40°C is heated to 80°C . Explain

9. State the observation that would be made when a piece of sodium metal is placed in samples of:
Pentane: _____
Pentanol: _____
10. D gm of potassium hydroxide were dissolved in distilled water to make 100cm^3 of solution. 50cm^3 of the solution- required 50cm^3 of 2 M nitric acid for complete neutralization. Calculate the mass D, of potassium hydroxide $(\text{KOH})(\text{aq}) + \text{HNO}_3(\text{aq}) \rightarrow \text{KNO}_3(\text{aq}) + \text{H}_2\text{O}(\text{l})$ Relative formula mass of KOH = 56
11. In an attempt to prepare sulphur dioxide gas, dilute sulphuric acid was reacted with barium sulphuric. The yield of sulphur dioxide was found to be negligible explain
12. The curve below represents the changes in the concentration of substance E and F with time

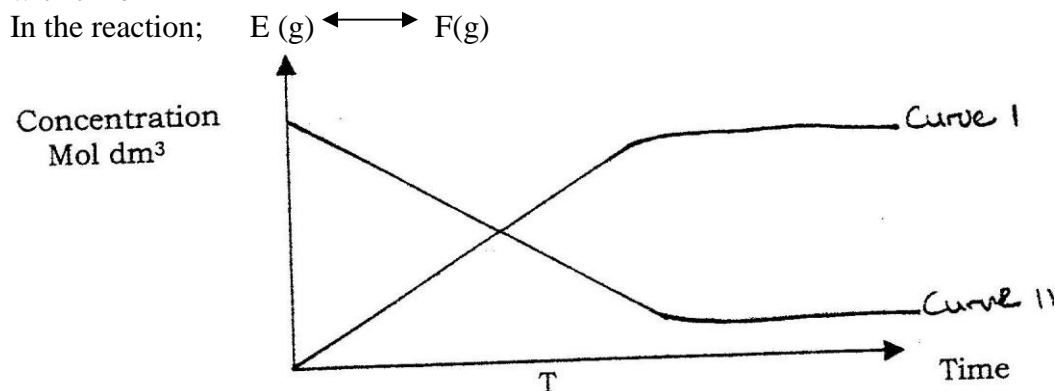

- (i) Which curve represents the changes in concentration of substance F?
Give a reason
- (ii) Give a reason for shapes of curves after time 't' minutes
13. Use the cell representation below to answer the questions that follow

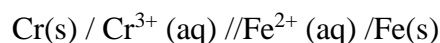

(a) Write the equation for the cell reaction

(b) If the E.M.F of the cell is 0.30 volts and the E^\ominus value for Cr^{3+}/Cr (s)

14. (a) A few drops of freshly prepared iron (II) sulphate solution were added to potassium nitrate solution in a test – tube. Concentrated sulphuric acid was then carefully added to the mixture. State the observation that were made

(b) Write an equation for the reaction that occurs when solid potassium nitrate is strongly heated



15. Use the information below to answer the question that follows

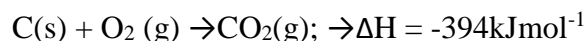

Calculate the enthalpy change for the reaction

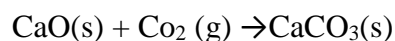

16. Under certain conditions, carbon dioxide reacts with water to form methanol (CH_3OH) and oxygen as shown below



What would be the effect on the yield of methanol if the temperature of the reaction mixture is increased? Explain

In an experiment a certain volume of air was passed from syringe to syringe over heated zinc powder as shown in the diagram below

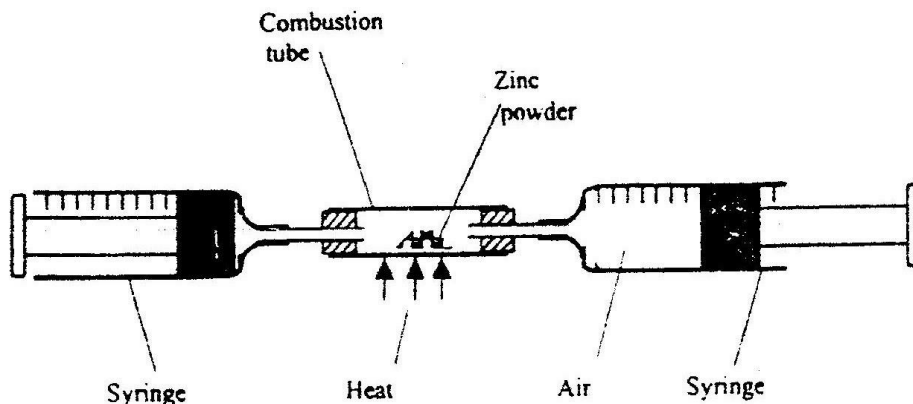

The experiment was repeated using excess magnesium powder. In which of two experiments was the change in volume of the air greatest. (Give reasons)

17. Use the information in the table below to answer the questions that follows

Element	Fluorine	Chlorine	Bromine	Iodine
Heat of vaporization	3.16	10.2	15.0	22.0

Explain the trend in the molar heats of vaporization

18. The diagram below shows a set up for the laboratory preparation and collection of dry chlorine gas

(a) Name

(i) Substance G

(ii) A suitable drying agent Conc.

(b) What property of chlorine makes it possible for it to be collected as shown in the diagram?

19. The set up below was used to investigate some properties of two gases M and N

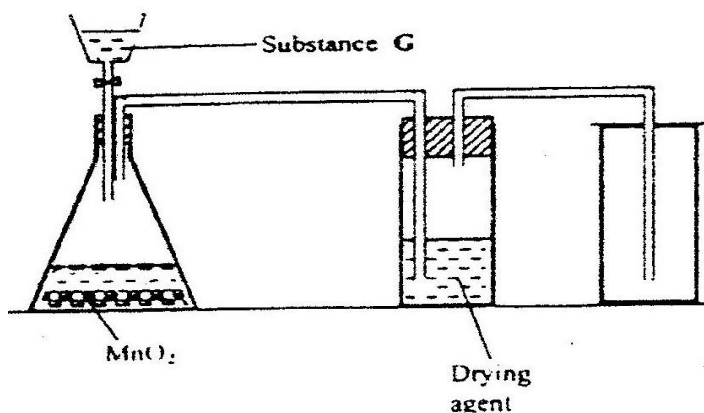

a) Name

(i) Substance G

(ii) A suitable drying agent conc.

b) What property of chlorine makes it possible for it to be collected as shown in the diagram?

20. The set up below was used to investigate some properties of two gases M and N

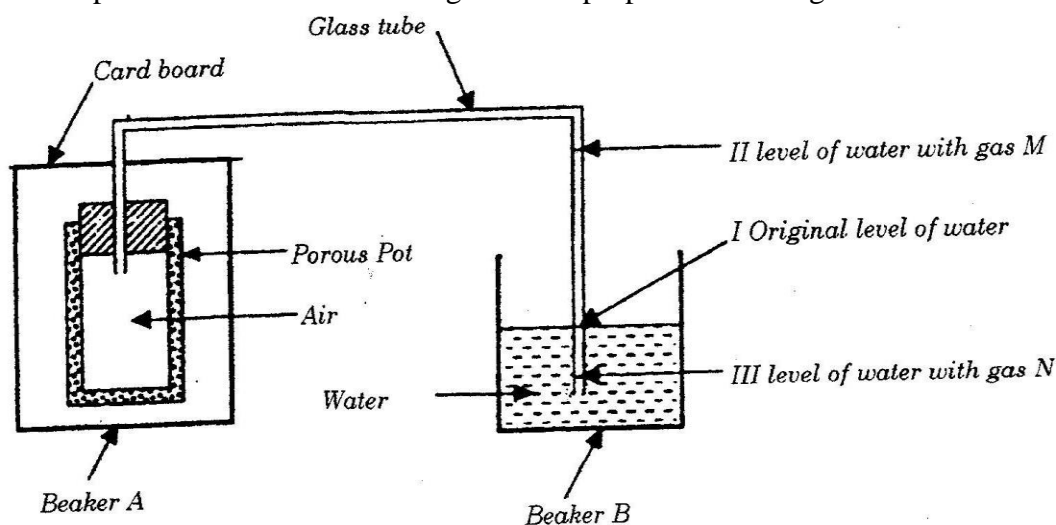

When beaker A was filled with gas M, the level of water in the glass tube rose to point II. When the experiment was repeated using gas N, the level of water dropped to point III. Explain these observations.

21. State and explain one disadvantages of using hard water in boilers

22. Compound L reacts with hydrogen bromide gas to give another compound whose structure is

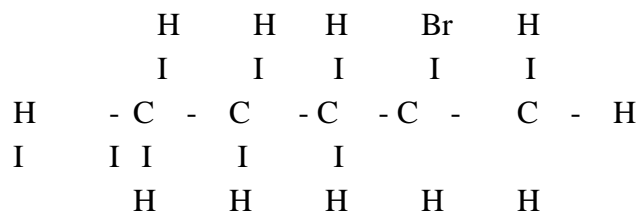

- (a) Give the structural formula and name of compound L
 (b) Write an equation for the reaction, which takes place between ethane and excess chlorine gas
23. When excess carbon monoxide gas was passed over heated lead (II) oxide in combustion tube, lead (II) oxide was reduced
- (a) Write an equation for the reaction, which took place
 (b) What observation was made in the combustion tube when the reaction was complete?
 (c) Name another gas, which could be used to reduce lead (II) oxide
24. One of the fuels associated with crude oil is natural gas. Name the main constituent of natural gas and write an equation for its complete combustion Name:

Equation:

25. When solid magnesium carbonate was added to a solution of hydrogen chloride in methylbenzene, there was no apparent reaction. On addition of water to the resulting mixture, there was vigorous effervescence. Explain these observations

26. The graph below shows the mass of a radioactive isotope plotted against time

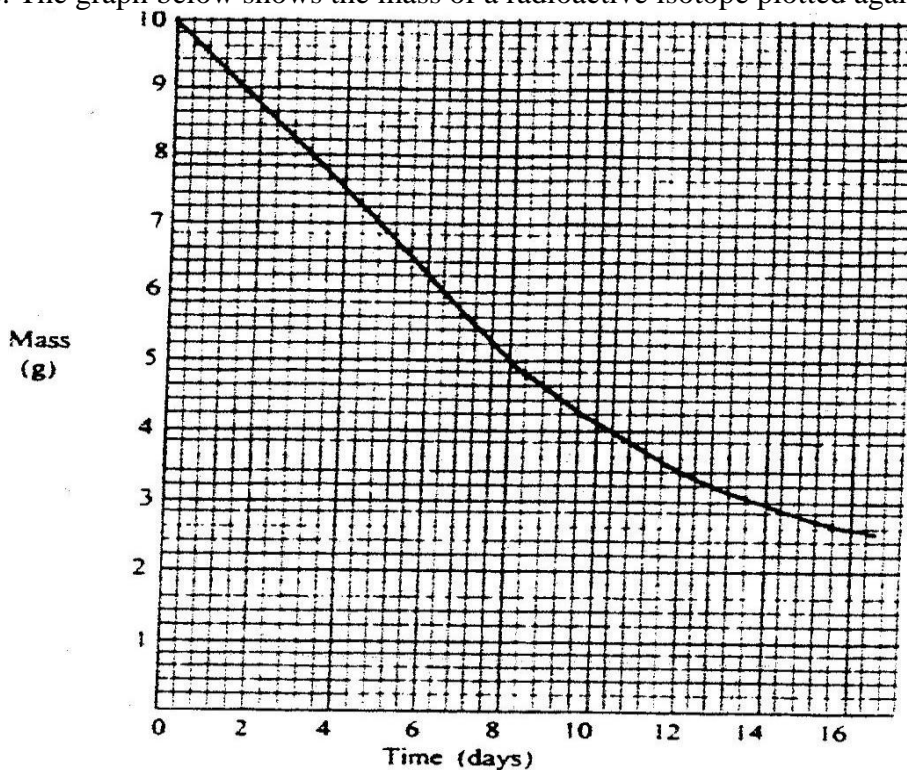

- (a) Using the graph, determine the half-life of the isotope
 (b) Calculate the mass of the isotope present after 32 days
27. The table below shows the P^{H} values of solutions I, II, III and IV.

Solution	I	II	III	IV
p ^H	2	7	11	14

- (a) which solution is likely to be that of calcium hydroxide?
- (b) Select the solution in which a sample of aluminium oxide is likely to dissolve. Give reason for your answer

28. Bromine reacts with ethane as shown below

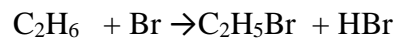

- (a) What condition is necessary for this reaction to occur?
- (b) Identify the bonds which are broken and those that are formed

Bonds broken

Bonds formed

CHEMISTRY PAPER 233/2 K.C.S.E 1999

QUESTIONS

1. The table below gives the volume of the gas provided when different volumes of 2M hydrochloric were reacted with 0.6g of magnesium powder at room temperature

Volume of 2M hydrochloric (cm ³)	Volume of gas (cm ³)
0	0
10	240
20	480
30	600
40	600
50	600

- (a) Write an equation for the reaction between magnesium and hydrochloric acid
- (b) On the grid provided plot a graph of the volume of gas produced (vertical axis), against the volume of acid added (Note the reaction comes to completion, the volume of the gas produced directly proportional to completion, the acid added).
From the graph determine
- (c) i) The volume for the gas produced if 12.5cm³ of 2M hydrochloric acid had been used.
ii) The volume of 2M hydrochloric acid which when reacted completely with 0.6 of magnesium powder.
- e) Given that one mole of the gas occupied 24000cm³ at room temperature.

Calculate the relative atomic mass of magnesium.

2. The set – up below was used during the electrolysis of aqueous magnesium sulphate using inert electrodes.

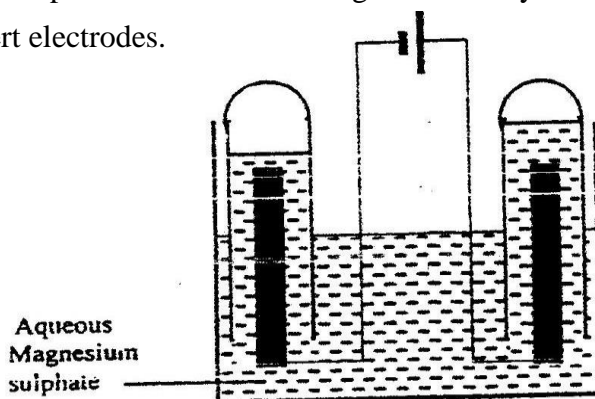

- i) name a suitable pair of electrodes for this experiment
- ii) Identify the ions and cations in the solution
- iii) On the diagram label the cathode
- iv) Write ionic equations for the reactions that took place at the anode.

- v) Explain the change that occurred to the concentration of magnesium sulphate solution during the experience.
- vi) During the electrolysis a current of 2 amperes was passed through the solution for 4 hours. Calculate the volume of the gas produced at the anode. (1 faraday 96500 coulombs and volume of a gas at room temperature is 24000cm³)
- vii) One of the uses of electrolysis is electroplating. What is meant by electroplating?

Give two reasons why electroplating is necessary.

3. Study the information in the table below and answer the questions that follow. The letters do not represent the symbols of the elements.

Element(C)	Atomic number	Melting point
L	11	97.8
M	13	660
N	14	1440
Q	17	401
R	19	63.7

- a) Write the electrons arrangement for the atom formed by elements M and Q
- b) Select an element which is
- The most reactive non – metal
 - A poor conductor of electricity
- c) In which period of the periodic table does element R belong?
- d) Element R loses its outermost electron more readily than L. Explain
- e) Using dots (.) and crosses (x) to represent outermost electrons show bonding in the compound formed by elements N and Q.
- f) Explain why the melting point of element M is higher than that of element L.
- g) Describe how a solid mixture of sulphate of R and lead sulphate can be separated into solid samples.
4. a) The flow chart below shows a sequence of reactions starting with Iron. Study and answer the questions that follow.

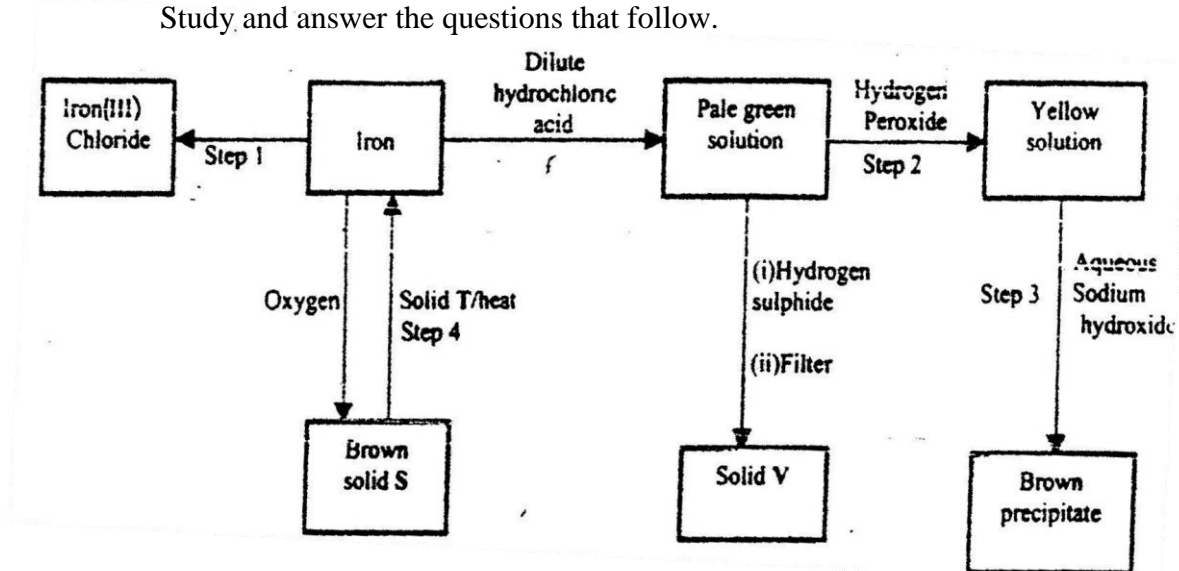

- i) Name the reagent and state the condition for the reaction in step 1.
- Reagent

Condition

- ii) Give the names of the following
- i) Solid S
 - ii) Solid V
 - iii) Solid T
- iii) Give reasons for the colour change in step 2 ii) Write an ionic equation for the reaction which takes place in step 3.
- v) Name one other substance that could be used instead of sodium hydroxide in step III.
- b) In an experiment 3.36g of iron fillings were added to excess aqueous copper(II) sulphate. Calculate the mass of copper that was deposited. $\text{Cu} = 63.5, \text{Fe} = 56.0$
- 5 a) When an organic compound Y is reacted with aqueous sodium carbonate, it produces carbon dioxide reacts with propanol to form a sweet smelling compound Z whose formula is.

O

||

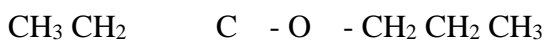

- i) Name and draw the structural formula of compound Y.
 - ii) What is the name of the group of compounds to which Z belongs?
- b) In an experiment excess ethanol was warmed with potassium dichromate for about twenty minutes. State and explain the observation that was made at the end of the experiment.
- c) The scheme below was used to prepare a cleaning agent.

Study follow.

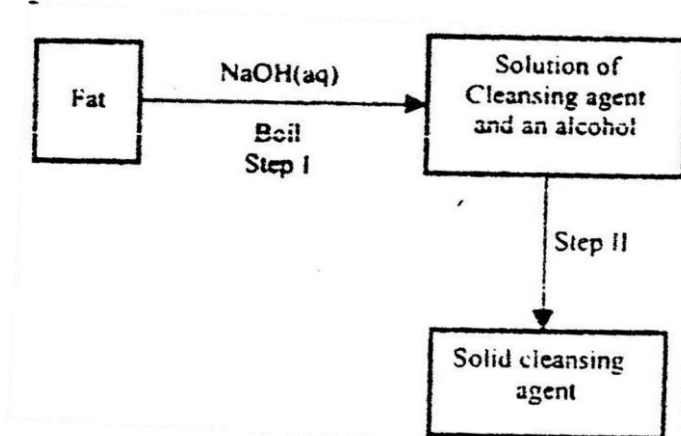

and answer the questions that

- i) What name is given to the type of cleaning agent prepared by the method shown in the scheme?
- ii) Name one chemical substance added in step II iii) What is the purpose of adding the elements substance names in C(ii) above.
- iv) Explain how an aqueous solution of the cleansing removes oil from utensils during washing.

6. a) The diagram below shows a set-up used by a student in an attempt to prepare and collect oxygen gas.

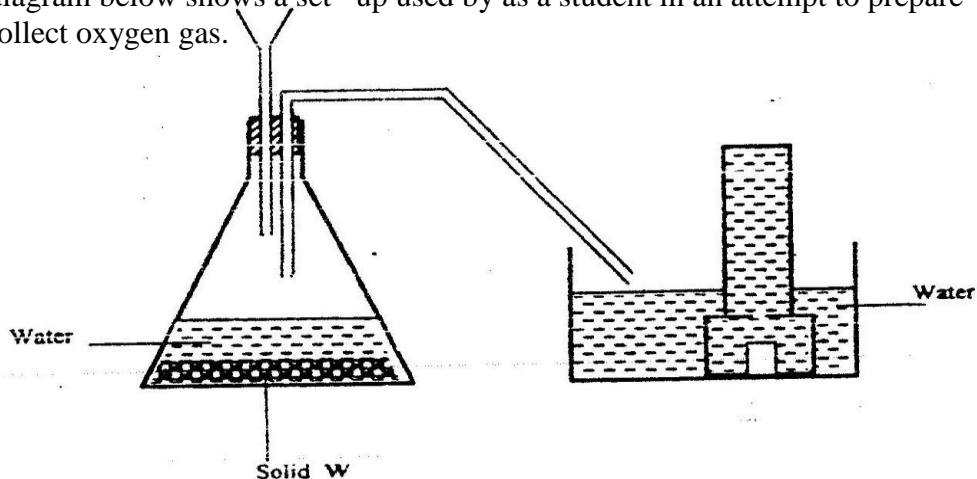

- i) Complete the diagram correcting the mistakes on it
 - ii) Identify solid W.
- b) A piece of phosphorus was burnt in excess and the product obtained was shaken with a small amount of hot water to make a solution.
 - i) Write an equation for the burning of phosphorus in excess air.
 - c) Explain why cooking pots made of aluminium do not corrode when exposed to air.
 - d) The reaction between sulphur dioxide and oxygen to form trioxide in the contact process is exothermic.

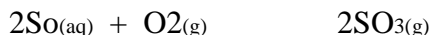

Factory manufacturing sulphuric acid by contact process produces 350kg of sulphur trioxide per day (conditions) for the reaction catalyst. 2 atmospheres pressure and temperatures between. (400 – 500 °C)

- i) What is meant by an exothermic reaction?
- ii) How would the yield per day of sulphur trioxide be affected if temperatures lower than 400°C are used? Explain.

CHEMISTRY PAPER 233/1 K.C.S.E 2000

QUESTIONS

1. Explain the change in mass that occurs when the following substances are separately heated in open crucibles
 - (a) Copper metal
 - (b) Copper (II) nitrate
2. The equation below represents a redox reaction

$$\text{Mg} (\text{s}) + 2\text{HCl} (\text{aq}) \rightarrow \text{MgCl}_2 (\text{aq}) + \text{H}_2$$
 - a) Write down the equation for the reduction process
 - b) Which substance is oxidized
3. The simplified flow chart shows some of the steps in the manufacture of sodium carbonate

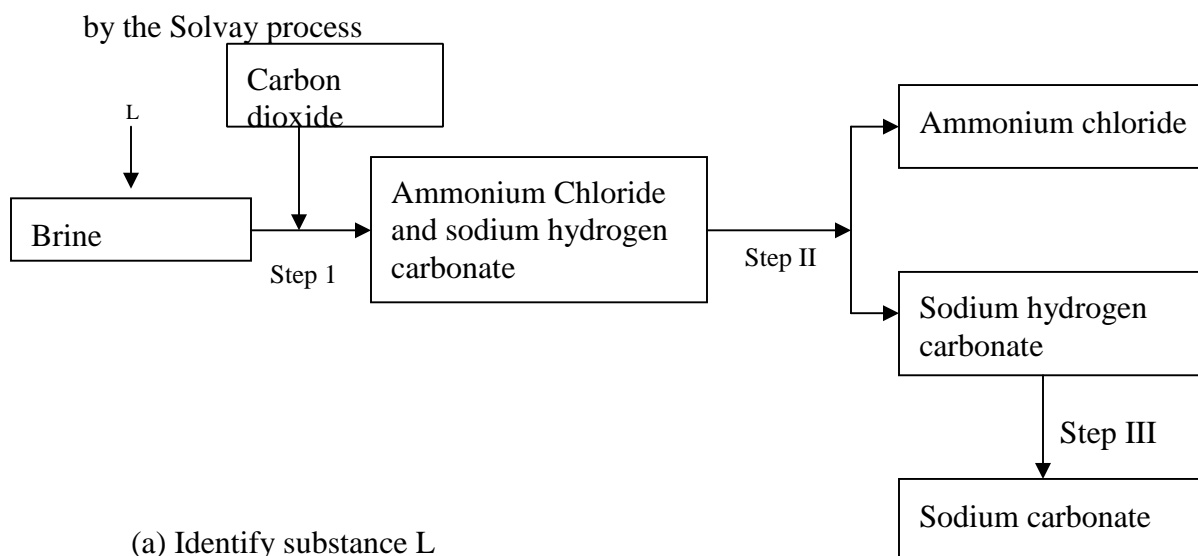

- (a) Identify substance L
 - (b) Name the process – taking place in step II
 - (c) Write an equation for the reaction, which takes place in step III
4. When a current of 1.5 amperes was passed through a cell containing m^{3+} ions of a metal M for 15 minutes, the mass of the cathode increased by 0.26g.
(1 Faraday = 96500 coulombs)
 - (a) Calculate the quantity of electricity used
 - (b) Determine the relative atomic mass of metal M
 5. The information below relates to elements S, T, U and X. (the letters do not represent the actual symbols of the elements.)
 - (i) T displaces X from an aqueous solution containing ions of X
 - (ii) Hydrogen gas reduces heated oxide of S but does not reduce the heated oxide of X
 - (iii) U liberates hydrogen gas from cold water but T does not
 - (a) Write an equation for the reaction between T and the ions of X.
Both T and X are in group II of the periodic Table)
 - (b) Arrange the elements in order of their increasing reactivity
 6. Starting with copper metal, describe how a solid sample of copper (II) carbonate can be prepared.
 7. Give two reasons why helium is used in weather balloons
 8. Study the solubility curves below and answer the questions that follow

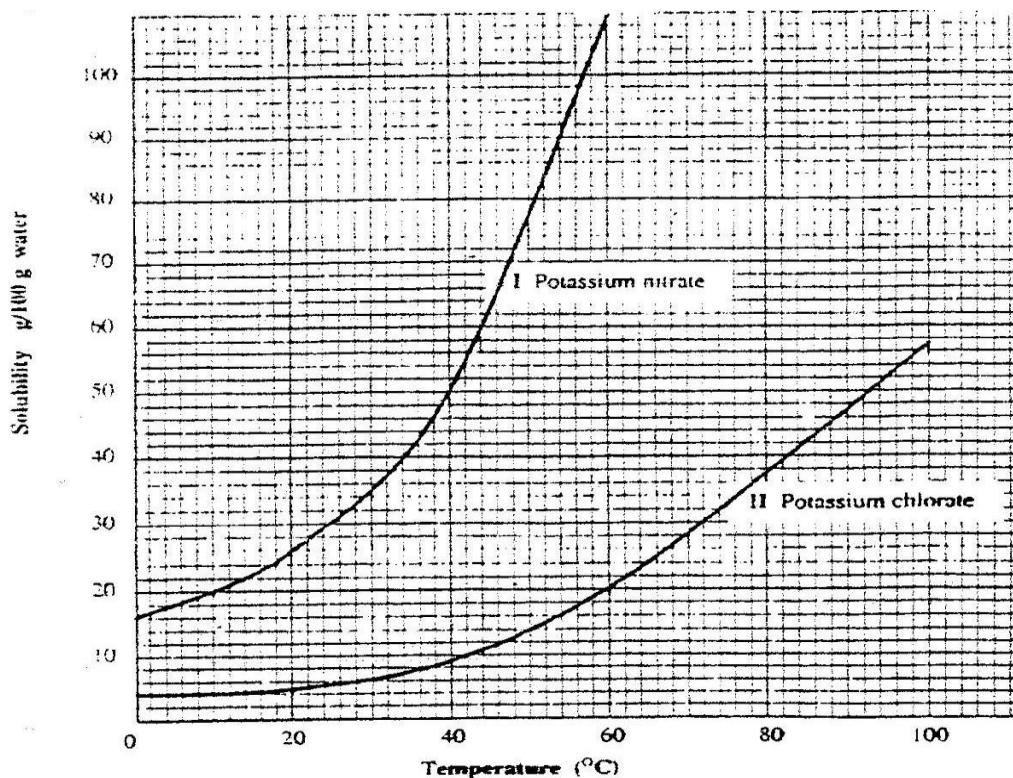

What happens when a solution containing 40gm of potassium chlorate and 40gm of potassium nitrate in 100gm of water at 90°C is cooled to 40°C? Explain

9. A hydrocarbon P was found to decolourise bromine water. On complete combustion of 2 moles of P, 6 moles of carbon dioxide and 6 moles of water were formed
- Write the structural formula of P
 - Give the name of P
 - Name one industrial source of P
10. Use the scheme below to answer the questions that follow

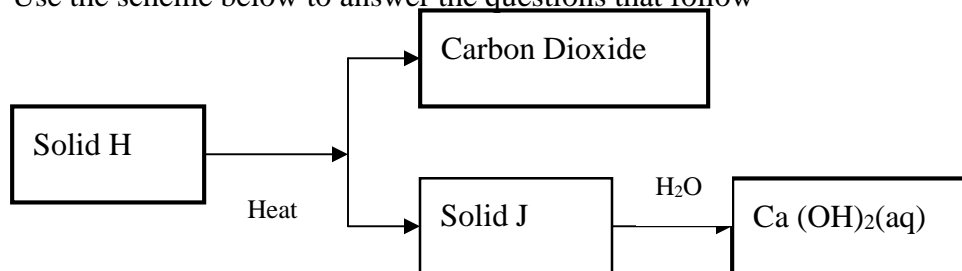

- Identify the solid
H
J
- State one commercial use of solid J

11. 20.0cm³ of a solution containing 4 gm per litre of sodium hydroxide was neutralized by 8.0cm³ of dilute sulphuric acid. Calculate the concentration of sulphuric acid in moles per litre (Na = 23.0, O = 16.0, H = 1.0)

12. A student set up the apparatus shown below to prepare ammonia gas and react it with copper (II) sulphate solution.

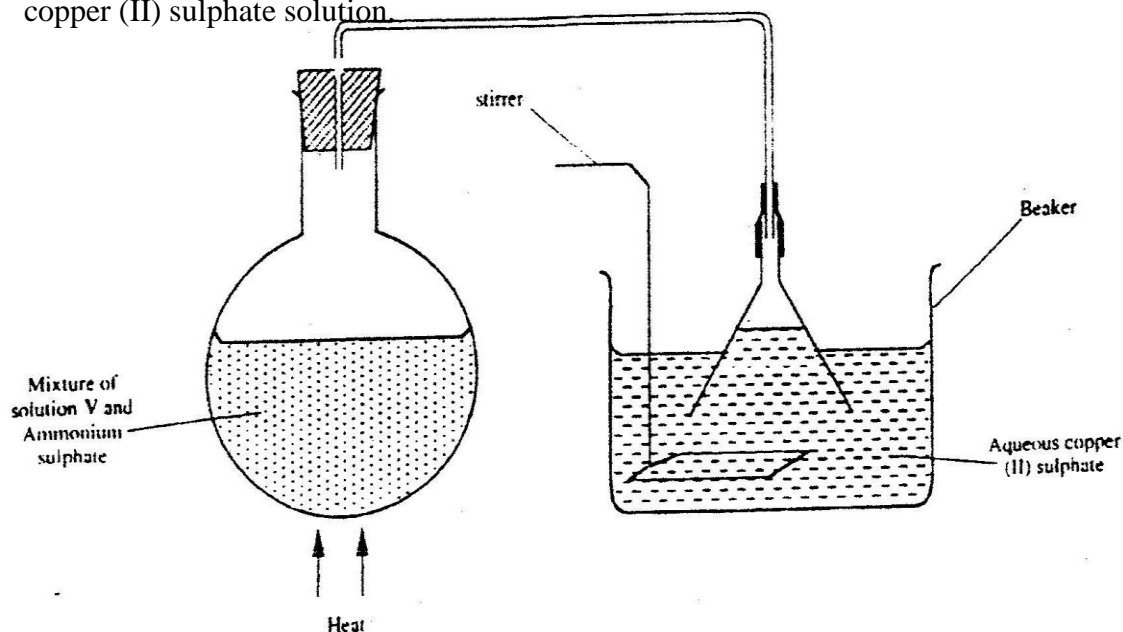

- (a) Identify solution V
 (b) State the observations which were made in the beaker
13. A radioactive isotope X_2 decays by emitting two alpha (α) particles and one beta (β) to form ${}_{83}^{214}\text{Bi}$

83

- (a) What is the atomic number of X_2 ?
 (b) After 112 days, $1/16$ of the mass of X_2 remained. Determine the half life of X_2
14. The table below shows the tests carried out on separate samples of water drawn from a well and the results obtained

Tests	Results
(i) Addition of excess aqueous	
(ii) Addition of a few drops of dilute sulphuric acid	
(iii) Addition of dilute hydrochloric acid followed by few drops of Barium chloride	

- (a) Identify the cation and the anion present in the water

Cation

Anion

- (b) Write an ionic equation for the reaction which takes place in test (iii)

15. State any two differences between luminous and non – luminous flames

16. Compound Q is a solid with a giant ionic structure. In what form would the compound conduct an electric current

17. Study the set-up below and answer the questions that follow

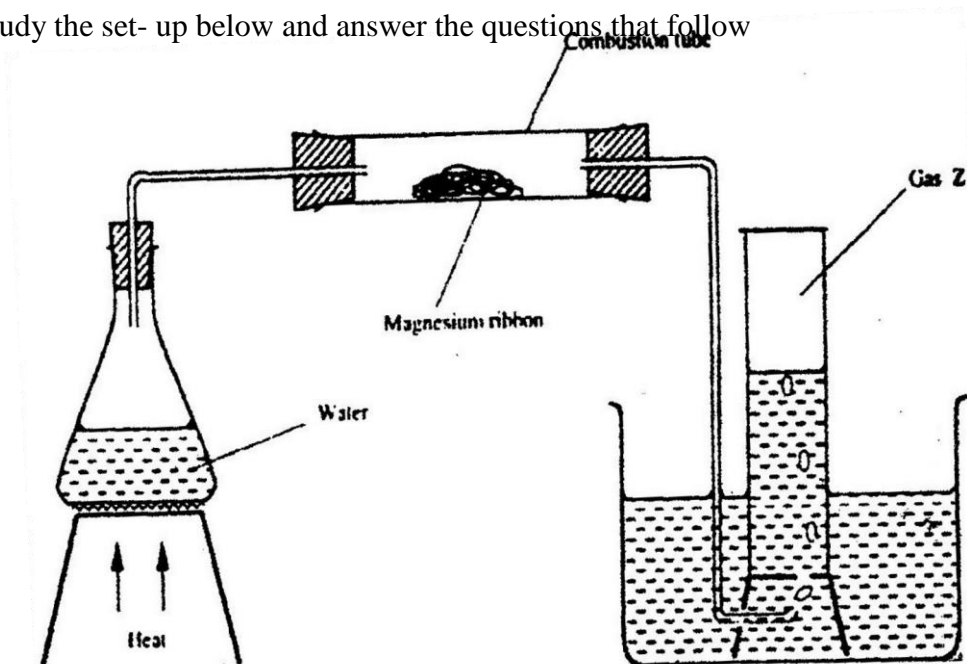

- (a) Write an equation for the reaction, which take place in the combustion tube
 (b) What property of gas Z allows it to be collected as shown in the diagram
18. A given volume of ozone, (O_3) diffused from a certain apparatus in 96 seconds. Calculate the time taken by an equal volume of carbon dioxide (CO_2) to diffuse under the same conditions ($O = 16.0$, $C = 12.0$)
19. The curves below were obtained when two equal volumes of hydrogen peroxide of the same concentration were allowed to decompose separately. In one case, manganese (IV) oxide was added to the hydrogen peroxide

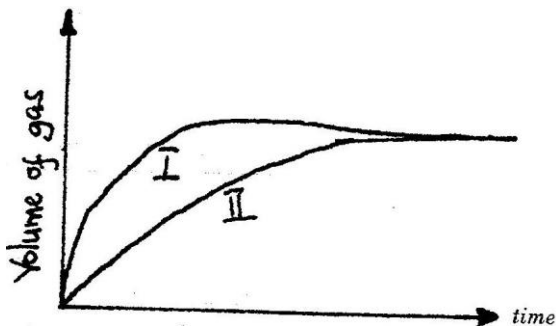

Which curve represents the decomposition of hydrogen peroxide with manganese (IV) oxide?
 Explain

20. Pentane and ethanol are miscible. Describe how water could be used to separate a mixture of pentane and ethanol
21. Name another gas, which is used together with oxygen in welding
22. Study the information in the table below and answer the questions that follow. The letters do not represent the actual symbols of the elements)

Element	Electrical conductivity	Ductility	Action of water
A	Good	Good	No reaction
B	Good	Poor	No reaction
C	Good	Good	Reacts

Select an element which

- (a) Is likely to be sited in group II of the periodic table
 - (b) Could be used to make electric cables
 - (c) Likely to be graphite
23. When a solid sample of sulphur is heated in a test tube, it changes into a liquid, which flows easily. On further heating, the liquid darkens and does not flow easily. Explain these observations.
24. Hydrogen and fluorine react according to the equation below
- $$\text{H}_2(\text{g}) + \text{F}_2(\text{g}) \rightarrow 2\text{HF}(\text{g}); \Delta H = -538\text{kJ}$$
- (a) On the grid provided below, sketch the energy level diagram for the forward reaction
- (b) Calculate the molar enthalpy of formation of HF
25. Explain why it is not advisable to leave a Jiko with burning charcoal in a closed room where one is sleeping.
26. In an experiment, ammonia chloride was heated in a test tube. A moist red litmus paper placed at the mouth of the test tube first changed blue then red. Explain these observations
27. State and explain the function of tartaric acid in baking powder

CHEMISTRY PAPER 232/2 K.C.S.E 2000

- 0 (a) The grid given below represents part of the periodic table. Study it and answer the questions that follow. (The letters do not represent the actual symbols of the elements)

									A
					B				
	C				D		E		
	F								

- (i) What name is given to the group of elements to which C and F belong?
 - (ii) Which letter represents the element that is the least reactive?
 - (iii) What type of bond is formed when B and E react? Explain
- QUESTIONS**
- (iv) Write the formula of the compound formed when element D and oxygen gas react
 - (v) On the grid, indicate with a tick the position of element G which is in the third period of the periodic table and forms G^{3-} ions

- (b) Study the information in the table below and answer the questions that follow (the letters do not represent the actual symbol of the substances)

Substance	Melting Point ($^{\circ}$ C	Boiling Point ($^{\circ}$ C	Solubility in water	Density at room temperature g/cm
H	-117	78.5	Very soluble	0.8
J	-78	-33	Very soluble	0.77×10^{-3}
K	-23	77	Insoluble	1.6
L	-219	-183	Slightly soluble	1.33×10^{-3}

- (i) Which substance would dissolve in water and could be separated from the solution by fractional distillation? Give a reason
- (ii) Which substances is a liquid at room temperature and when mixed with water two layers would be formed?
- (iii) Which letter represents a substance that is gas at room temperature and which can be collected:
- Over water? Explain
 - By downward displacement of air? (Density of air is $1.29 \times 10^{-3} \text{g/cm}^3$ at room temperature.

- 1 (a) The diagram below represents a mercury cell that can be used in the industrial manufacture of sodium hydroxide. Study it and answer the question that follow

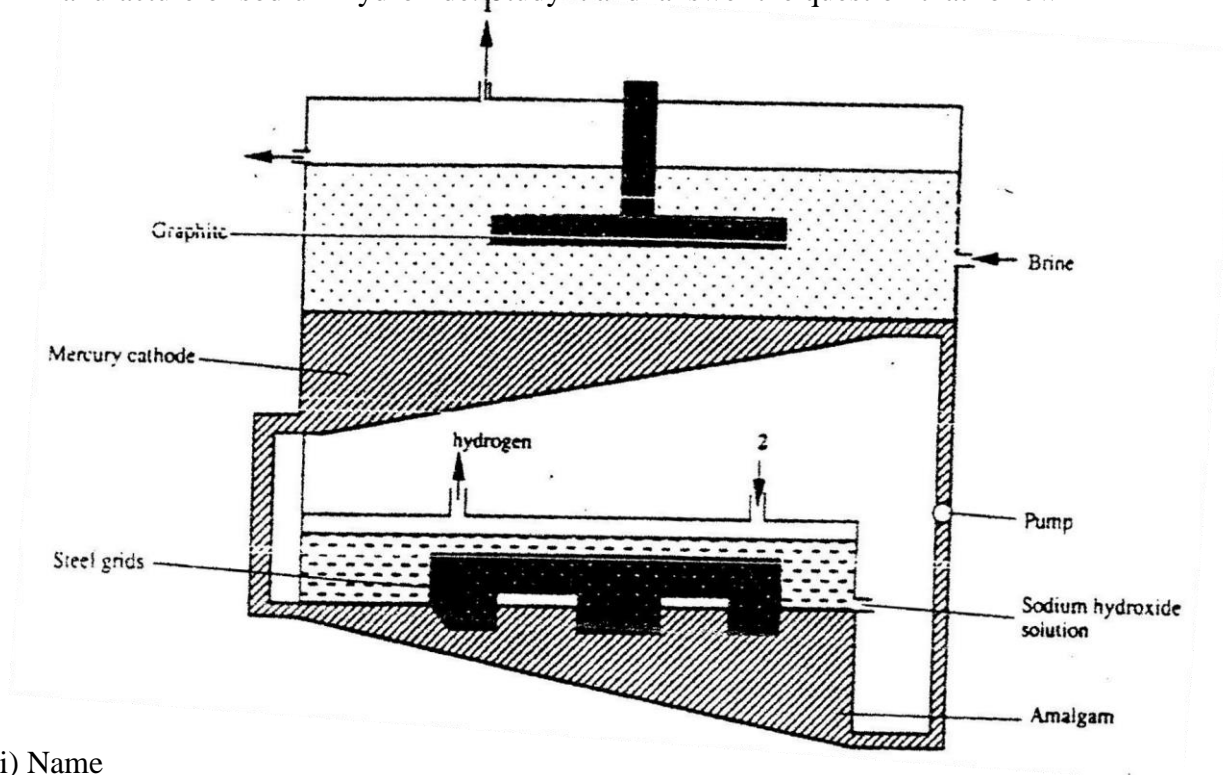

- (i) Name
- the raw material introduced at 2
 - Another substance that can be used in the cell instead of graphite
- (ii) Identify the by – product that comes out at I

(iii) Give

I. One use of sodium hydroxide

II. Two reasons why mercury is recycled

(b) A current of 100 amperes was passed through the cell of five (5) hours

(i) Write the equation for: The reaction that occurred at the mercury cathode

(ii) Calculate the mass of sodium hydroxide that was produced

(Na = 23.0, O = 16.0, H = 1.0, 1 Faraday = 96500 Coulombs)

2 The flow chart below illustrate the industrial extraction of lead metal. Study it and answer the questions that follow.

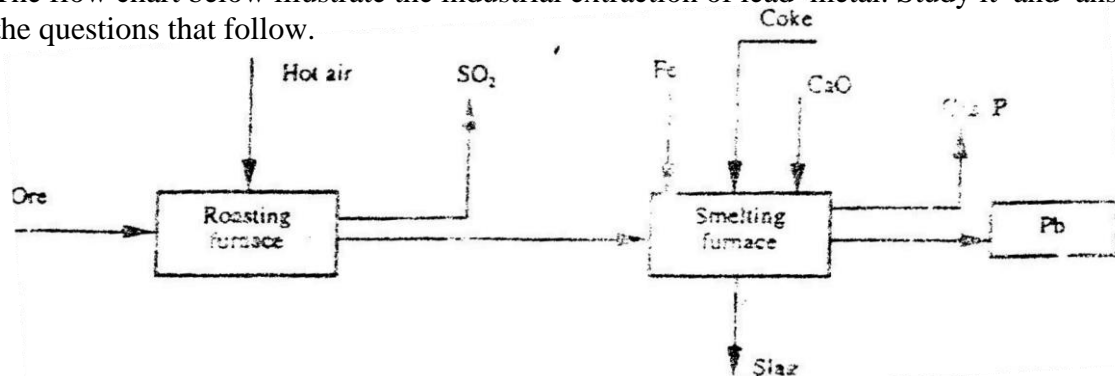

(a) (i) Name the ore that is commonly used in this process

(ii) Explain what takes place in the roasting furnace

(iii) Identify gas P

(iv) Write the equation for the main reaction that takes place in the smelting
Furnace

(v) What is the purpose of adding iron in the smelting furnace?

(vi) Give two environmental hazards likely to be associated with extraction of
Lead

(b) Explain why hard water flowing in lead pipes may be safer for drinking
than soft water flowing in the same pipes

(c) State one use of lead other than the making of lead pipes

4. (a) (i) In the space provided sketch a labeled diagram to show how hydrogen
chloride gas can be prepared and collected in the laboratory using sodium
Chloride and concentrated sulphuric acid (the gas need not be dry)

(ii) Write an equation for the reaction that takes place

(iii) Name one drying agent for hydrogen chloride

(vi) State and explain the observation that would be made when hydrogen
chloride gas is bubbled through a solution of lead (II) nitrate

(v) Concentrated hydrochloric acid is used for removing oxide from metal surfaces (picking). Explain why concentration nitric acid cannot be used for the purpose.

(b) A sample of hydrogen chloride gas was dissolved in water to make 250cm³ of
solution required 46 cm³ of 11.0M Sodium hydroxide for complete neutralization.

(i) Calculate the number of moles of hydrochloric acid in 25cm³ of solution

(ii) Determine the mass of hydrogen chloride that was dissolve to make 250cm³ of
solution (Cl = 35.5, H=1.0)

5. (a) Give the names of the following compounds

(i) CH₃CH = CHCH₂CH₃

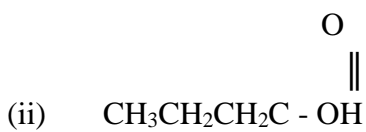

(b) Ethane and Ethene react with bromine according to the equation given below

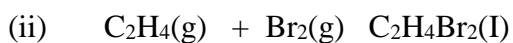
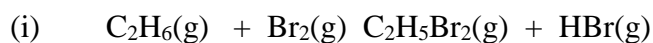

Name the type of bromination reaction that takes place in: (i) and (ii)

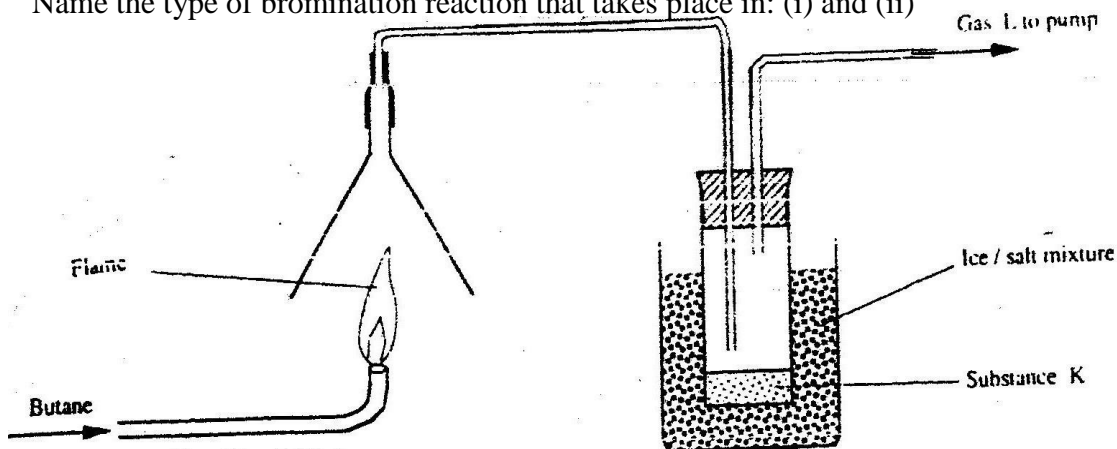

(i) Write the equation for the combustion of butane

(ii) The pH of substances K was found to be less than 7. Explain this observations

(d) The polymerization of tetra flouroathene (C_2F_4) is similar to that of ethane (C_2H_4)

(i) What is meant by the term polymerization?

(ii) Draw the structural formula of a portion of the polymer obtained from the monomer C_2H_4

(e) State any two advantages that synthetic polymers have over natural polymers

6. (a) The following diagrams show the structures of two allotropes of carbon. Study them and

answer the questions that follow

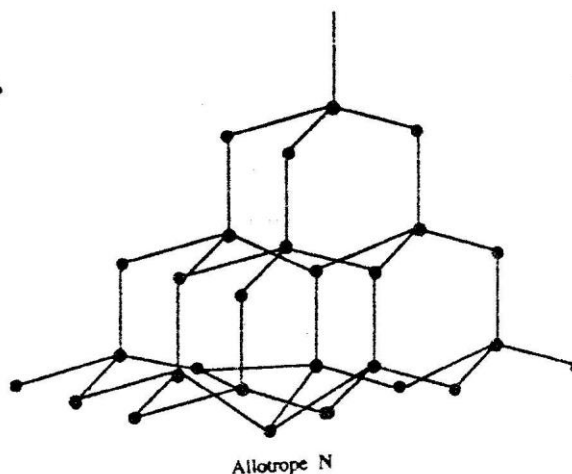
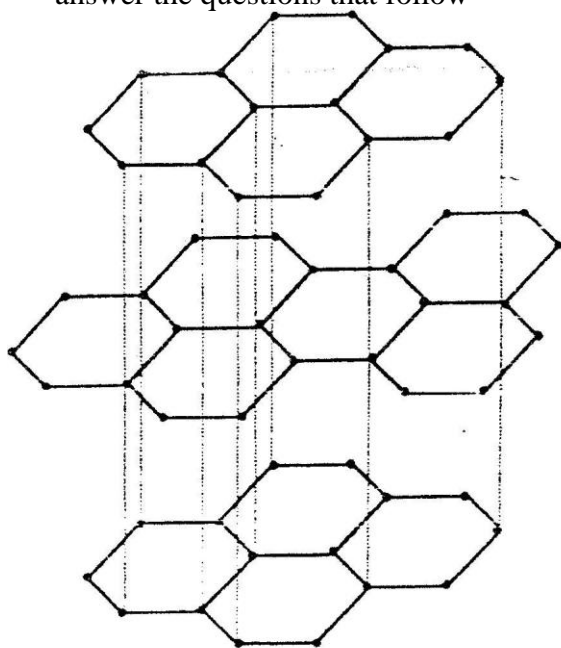

- (i) Name allotrope M
M
N
 - (ii) Give one use of N
 - (iii) Which allotrope conducts electricity? Explain
- (b) In an experiment, carbon dioxide gas was passed over heated charcoal and the gas produced collected as shown in the diagram below

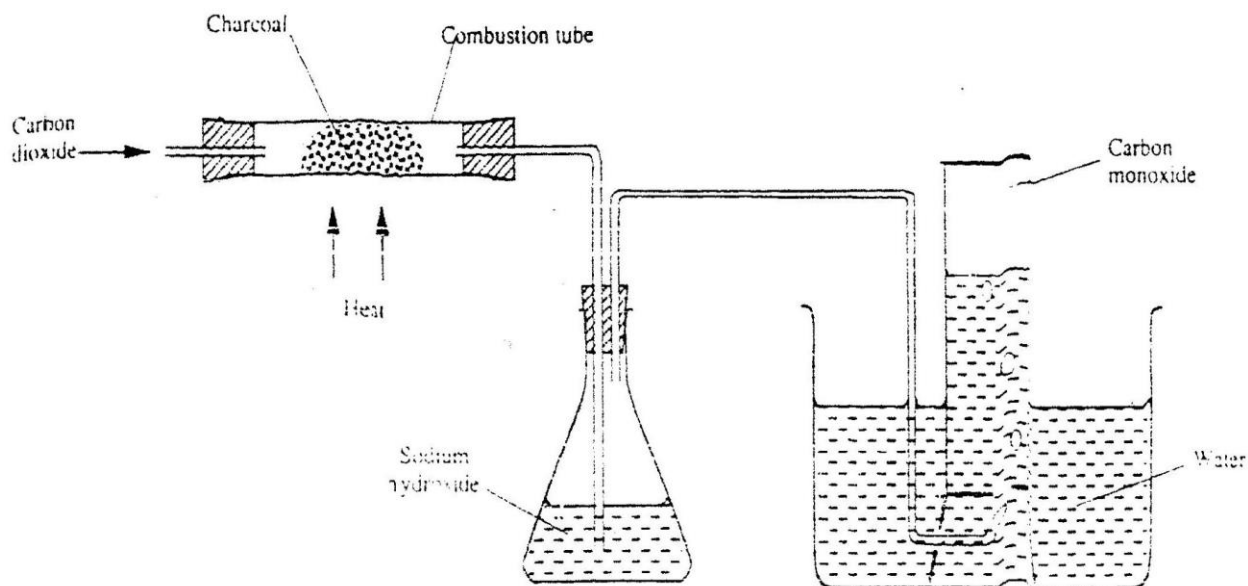

- (i) Write an equation for the reaction that took place in the combustion tube
 - (ii) Name another substance that can be used instead of sodium hydroxide
 - (iii) Describe a sample chemical test that can be used to distinguish between carbon dioxide and carbon monoxide
 - (iv) Give one use of carbon monoxide
- 7 (a) A student was supplied with a colourless liquid suspected to be water

- (i) Describe one chemical test that could have been used to show that the liquid was water (ii) How could it have been shown that the liquid was pure water?
- (b) The flow chart below shows the various stages of water treatment. Study it and answer the questions that follow

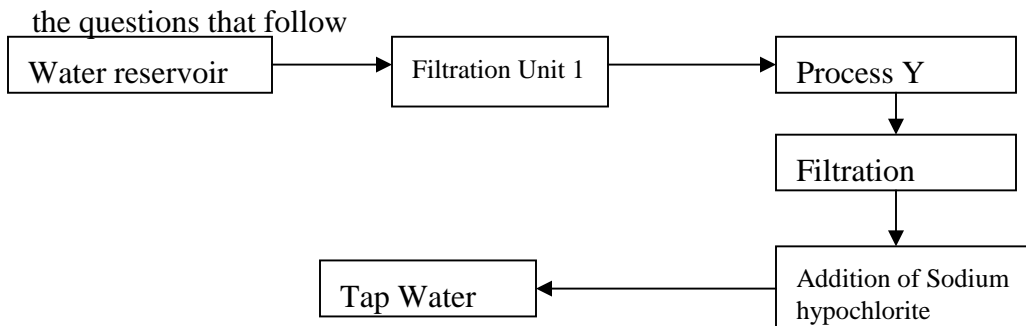

- (i) Which substances are likely to be removed in filtration unit I?
 (ii) What is the name of the process Y?
 (iii) What is the purpose?
- I Process Y
 II Addition of sodium hypochlorite
- (c) It was confirmed that magnesium sulphate was present in the tap water (i) What type of hardness was present in the water? (ii) Explain how the hardness can be removed

CHEMISTRY PAPER 233/1 K.C.S.E 2001 QUESTIONS

1. Study the nuclear reaction given below and answer the questions that follow.

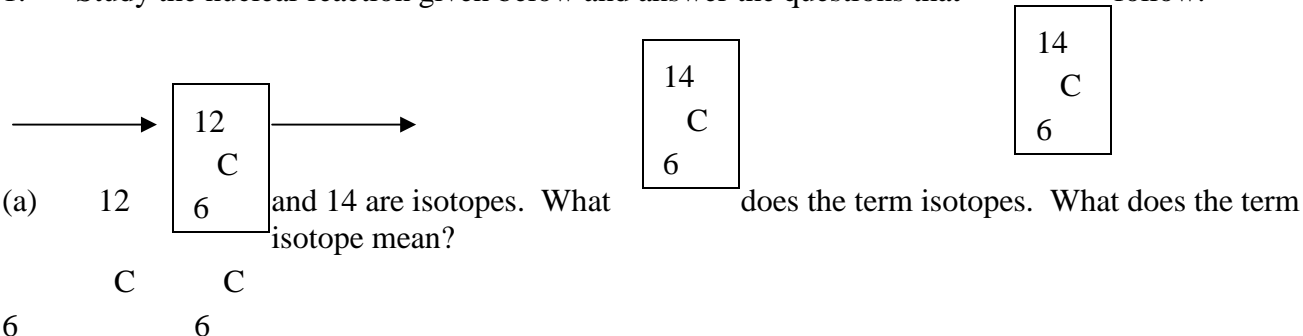

- (b) Write an equation for the nuclear reaction in step II

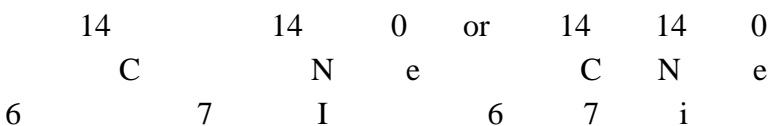

- (c) Give one use of $^{14}\text{C}_6$

2. In an experiment, 0.8gm of magnesium of powder were reacted with excess dilute sulphuric acid at 25°C . The time for the reaction to come to completion was recorded. The experiment was repeated at 40°C . In which experiment was the time taken shorter? Explain your answer.
3. The electronic structures for elements represented by letters A,B,C,D are

A=2 .8.6 B 2.8.2 C 2. 8. 1 D 2. 8. 8.

- a) Select the element which forms:
(i) a double charged cation
(ii) A soluble carbonate
- b) Which element has the shortest atomic radius?

4. Study the scheme below and answer the questions that follow.

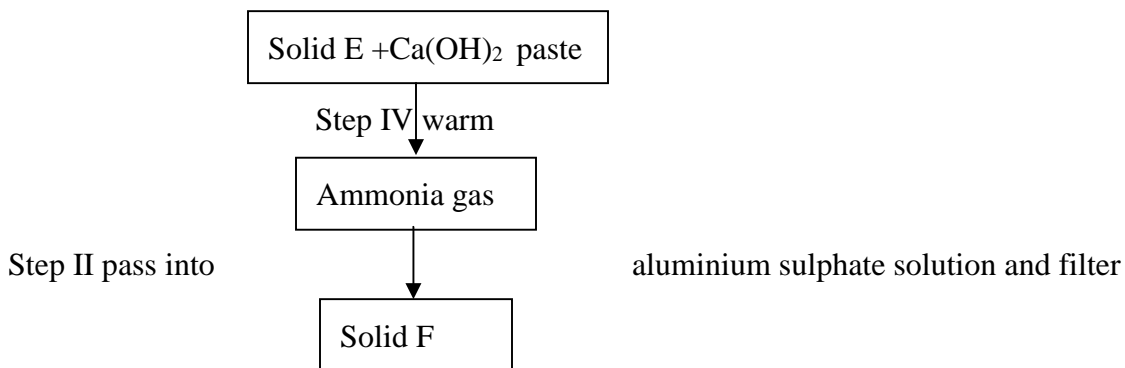

- a) Identify solid E.
b) Write an ionic equation for the reaction in step II that produces solid F.
5. Give a reason why phosphorus is stored under water.
6. At 298K and 1 atmosphere, graphite changes into diamond according to the equation:
$$\text{C (graphite)} \longrightarrow \text{C (diamond)}; \Delta H = 2.9 \text{ kJ mol}^{-1}$$

In the space provided, sketch a simple energy level diagram for the above change.
7. How would you obtain a sample of pure iodine from a mixture of iodine and lead sulphate?
8. 10gm of sodium hydrogen carbonate were dissolved in 20cm³ of water in a boiling tube. Lemon juice was then added drop wise with shaking until there was no further observable change.
- a) Explain the observation, which was made in the boiling tube when the reaction was in progress
b) What observation would have been made if the lemon juice had been added to copper turnings in a boiling tube? Give reason?
9. Sample solutions of salt were labeled as I, II, III and IV. The actual solutions, not in that order are lead nitrate, zinc sulphate potassium chloride and calcium chloride.
- a) When aqueous sodium carbonate was added to each sample separately, a white precipitate was formed in I, III and IV only. Identify solution II.
b) When excess sodium hydroxide was added to each sample separately, a white precipitate was formed in solutions III and I only.
Identify solution I
10. A weighed sample of crystalline sodium carbonate (Na₂CO₃ · H₂O) was heated in a crucible until there was no further change in mass.
Calculate the number of moles (n) of the water of crystallization
11. A certain matchstick head contains potassium chlorate and sulphure.

On striking the two substances react to produce sulphure dioxide and potassium chloride.
Explain the environmental effect of using such matches in large numbers.

12. Describe a simple laboratory experiment that can be used to distinguish between sodium and sulphide and sodium carbonate.
13. The information in the table below relates to elements in the same group of the periodic table. Study it and answer the question that follows:

Element	Atomic size
G1	0.19 0.23
G2	0.15
G3	

Which element has the highest ionization energy? Give reason.

14. When the oxide of element H was heated with powdered carbon the mixture glowed and carbon dioxide was formed. When the experiment was repeated using the oxide of element J, there was no apparent reaction.
- a) Suggest one method that can be used to extract element J from its oxide
- b) Arrange the elements H, J and carbon in the order of their decreasing reactivity.
15. When a sample of concentrated sulphuric acid was left in an open beaker in a room for two days, the volume was found to have increased slightly
- a) What property of concentrated sulphuric acid was left in an open beaker in a room for two days, the volume was found to have increased slightly.
- b) State one use of concentrated sulphuric acid that depends on the property named above.
16. The diagram below shows an iron bar, which supports a bridge. The Iron bar is connected to a piece of magnesium metal.

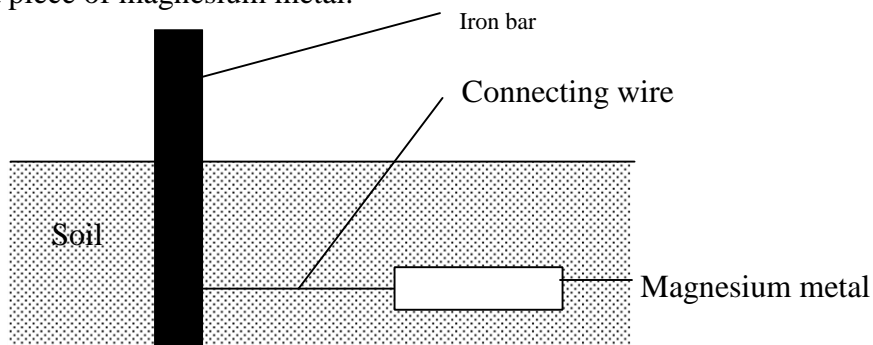

Explain why it is necessary to connect the piece of magnesium metal to the iron bar.

17. a) State one cause of temporary hardness in water.
b) How does distillation remove hardness from water?
18. In the presence of U.V light, ethane gas undergoes substitution reaction with chlorine.
- (a) What is meant by the term?
Substitution reaction:
- (b) Give the structural formula and the name of the organic product formed when equal volumes of ethane and chlorine react together.
19. Explain why burning magnesium continues to burn a gas was bubbled

Magnesium metal

20. a) what observation would be made if hydrogen sulphide gas was bubbled through a solution of zinc nitrate?
 b) write an equation for the reaction that takes place in (a) above

$$\text{Zn}(\text{NO}_3)_2(\text{aq}) + \text{H}_2\text{S}(\text{g}) \longrightarrow \text{ZnS} + 2\text{HNO}_3(\text{aq})$$
21. The apparatus shown below shown below was used to investigate the effect of carbon monoxide on copper (II)oxide.

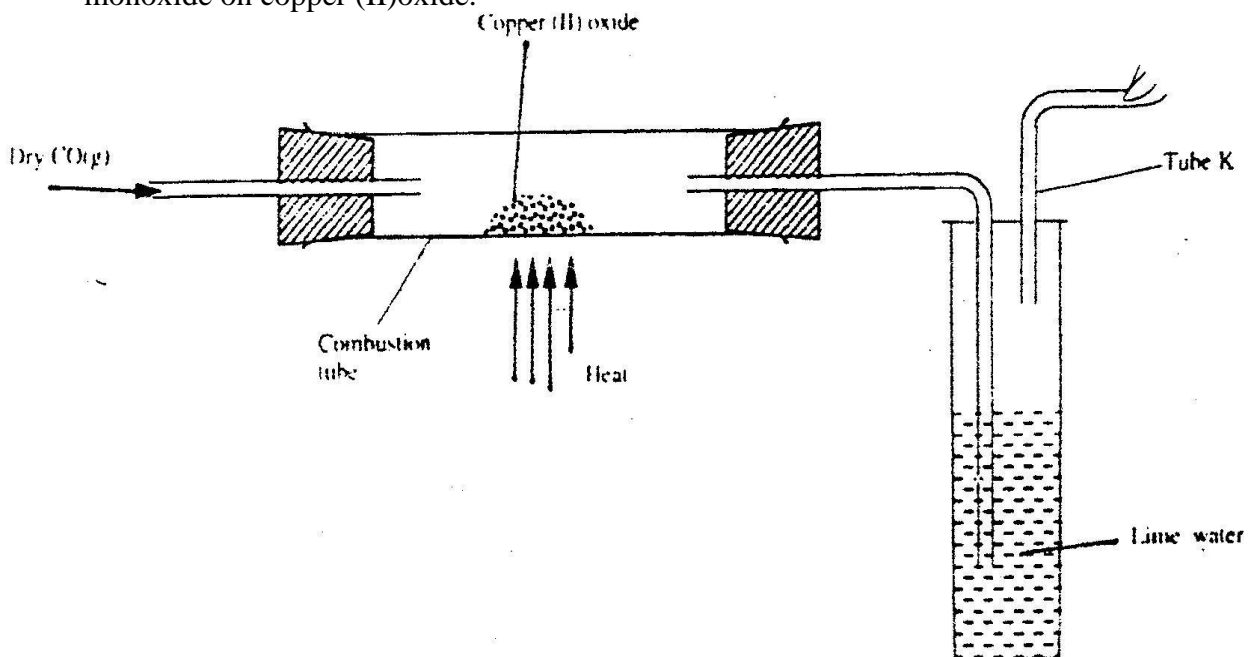

- a) State the observation that was made in the combustion tube at the end of the experiment.
 b) Write an equation for the reaction that took place in the combustion tube C)
 Why is it necessary to burn the gas coming out of tube K?
22. Explain why hydrogen forms compounds in which its oxidation state is either + 1 or -1 (Atomic number of hydrogen is 1)
23. The table below shows the properties of substances K,L,M and N

Substances	Reaction with oxygen at 25°C	Melting point	Conductivity Solid	Molten
K	Uncreative	Low	Poor	Good
L	Reactive			
M	Uncreative	High	Good	Good
N	Uncreative	Low	Good	Good

Select the substances which are likely to be:

- a) Copper metal
 b) Magnesium chloride

24. An element P has a relative atomic mass of 88. When a current of 0.5 amperes was passed through the fused chloride of P for 32 minutes and 10 seconds, 0.44g of P were deposited at the cathode. Determine the charge on an ion of P. (1 faraday = 96500 Coulombs).
25. The melting point of phosphorous dichloride is -91°C . While that of magnesium chloride is 715°C . In terms of structure and bonding, explain the difference in their melting points.
26. The Ph of a sample of soil was found to be 5.0. An agricultural office recommended the addition of calcium oxide in the soil. State two functions of the calcium oxide in the soil.
27. Hydrogen peroxide decomposes according to the equation below: $\text{H}_2\text{O}_2(\text{l}) \rightarrow \text{H}_2\text{O}(\text{l}) + \frac{1}{2}\text{O}_2(\text{g})$; $\text{H} = -98\text{kJ}$
 8.5 gm of hydrogen peroxide contained in 100cm^3 of solution with water were completely decomposed. Determine the rise in temperature due to the reaction. Specific density of water = 1g/cm^3 ($\text{O} = 16, \text{H} = 1$).

CHEMISTRY PAPER 233/2 K.C.S.E 2001

QUESTIONS

1. In an experiment to study the rate for reaction between duralumin (an alloy of aluminium, magnesium and copper) and hydrochloric acid, 0.5g of the alloy were reacted with excess 4M hydrochloric acid. The data in the table below was recorded.

Use it to answer the questions that follow.

Time (minutes)	Total volume of gas (cm^3)
1	0
2	220
3	410
4	540
5	620
6	640
7	640

- a) i) On the grid provided, plot a graph of total volume of gas produced (vertical axis) against time. ii) From the graph, determine the volume of gas produced at the end of $2\frac{1}{2}$ minutes. b) Determine the rate of reaction between the 3rd and 4th minute.
- c) Give a reason why some solid remained at the end of the experiment
- d) Given that 2.5cm^3 of the total volume of the gas was from the reaction between magnesium and aqueous hydrochloric acid, calculate the percentage mass of aluminium present in 0.5g of the alloy.
 ($\text{Al} = 27.0$ and Molar gas volume = $24,000\text{cm}^3$ at 298k)
- e) State two properties of duralumin that make it more suitable than aluminium in aeroplane construction.
2. a) In which homologous series do the following compounds belong
 i) CH_3CC
 ii) $\text{CH}_3\text{CH}_2\text{COO}$
- b) Raw rubber is heated with sulphur in the manufacture of natural rubber.
- i) What is the name given to the process ii)
 Why is the process necessary?
- c) Study the scheme given below and answer the questions that follow.

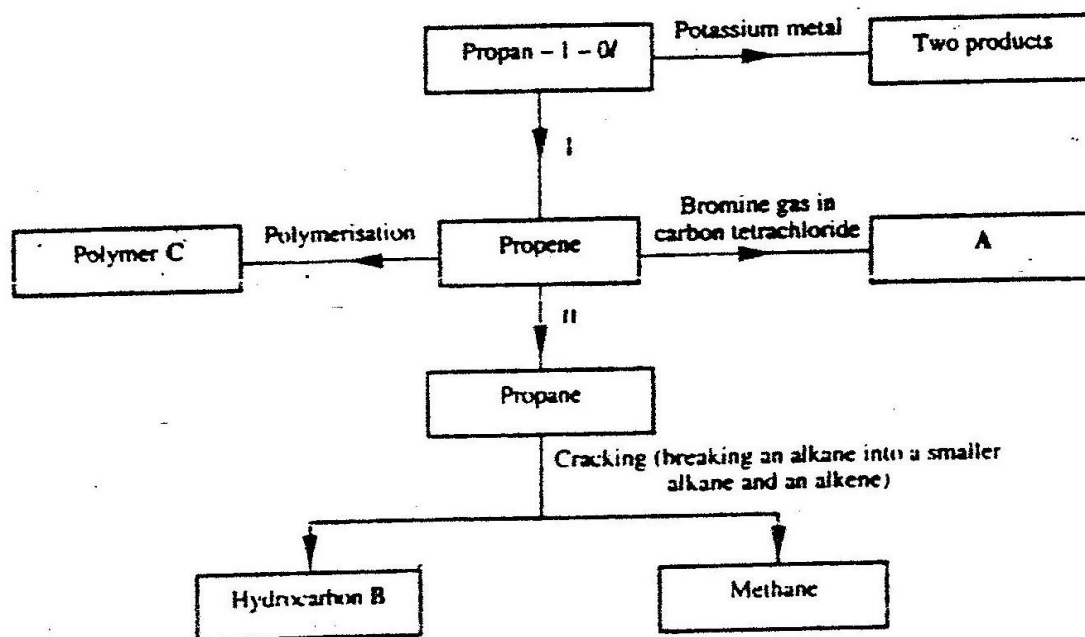

- i) Write an equation for the reaction between propane – 1 – 0 / and potassium metal.
- ii) Name processes I and II
 - I
 - II
- iii) Identify the products A and B
 - iv) Name one catalyst used in process II
 - v) Draw the structural formular of the repeating unit in the polymer C.
- d) State two industrial uses of methane.
3. a) Study the standard electrode potentials do the half – cells given below and answer the questions that follow.(The letters do nor represent the actual symbols of the elements.)

	E° volts	
$N^{+}_{aq} + e^{-} \rightleftharpoons N(s);$	-2.92	
$J^{+}_{(aq)} + e^{-} \rightleftharpoons J(s);$	+0.52	
$K^{+}_{(aq)} + e^{-} \rightleftharpoons \frac{1}{2} K_2(g)$	0.00	
$\frac{1}{2} G_2(g) + e^{-} \rightleftharpoons G(aq);$	+1.36	
$M^{2+}_{(aq)} + 2e^{-} \rightleftharpoons M(s);$	-0.44	

- i) Identify the strongest oxidizing agent. Give a reason for your answer.
- ii) Which two half – cells would produce the highest potential difference when combined?
- iii) Explain whether the reaction represented below can take place.

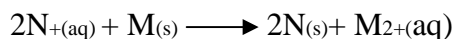

b)

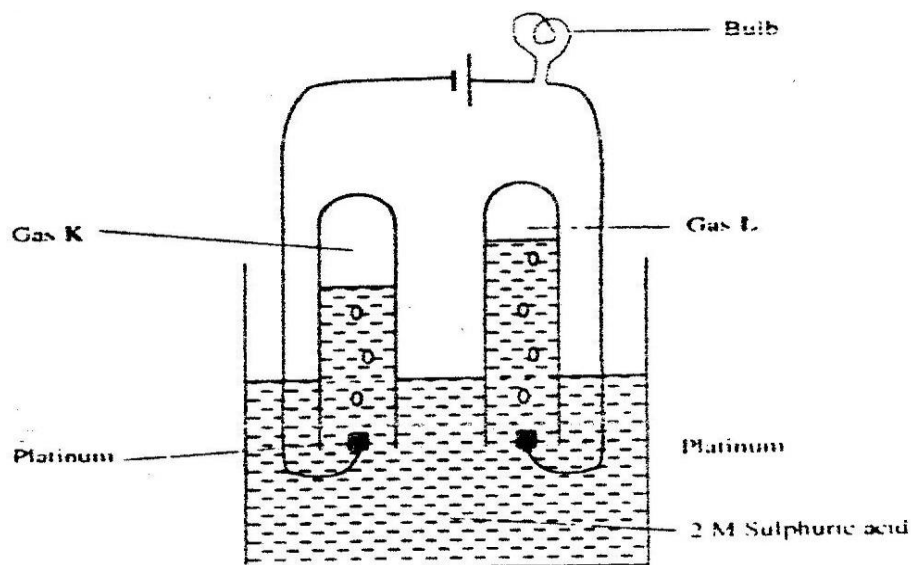

100cm³ of 2M sulphuric acid was electrolysed using the set – up represented by the diagram below.

- i) Write an equation for the reaction that produces gas L.
- ii) Describe how gas K can be identified
- iii) Explain the difference in :
 - I The volume of the gases produced at the electrodes.
 - II Brightness of the bulb if 100cm³ of 2M ethanoic acid was used in place of sulphuric acid.
4. a) Fraction distillation of liquid air usually produces nitrogen and oxygen as the major products.
 - i) Name one substance that is used to remove carbon dioxide from the air before it is changed into liquid.
 - ii) Describe how nitrogen gas is obtained from the liquid air.
(Boiling points nitrogen = - 196oC, oxygen = -183oC)

b) Study the flow chart below and answer the questions that follow.

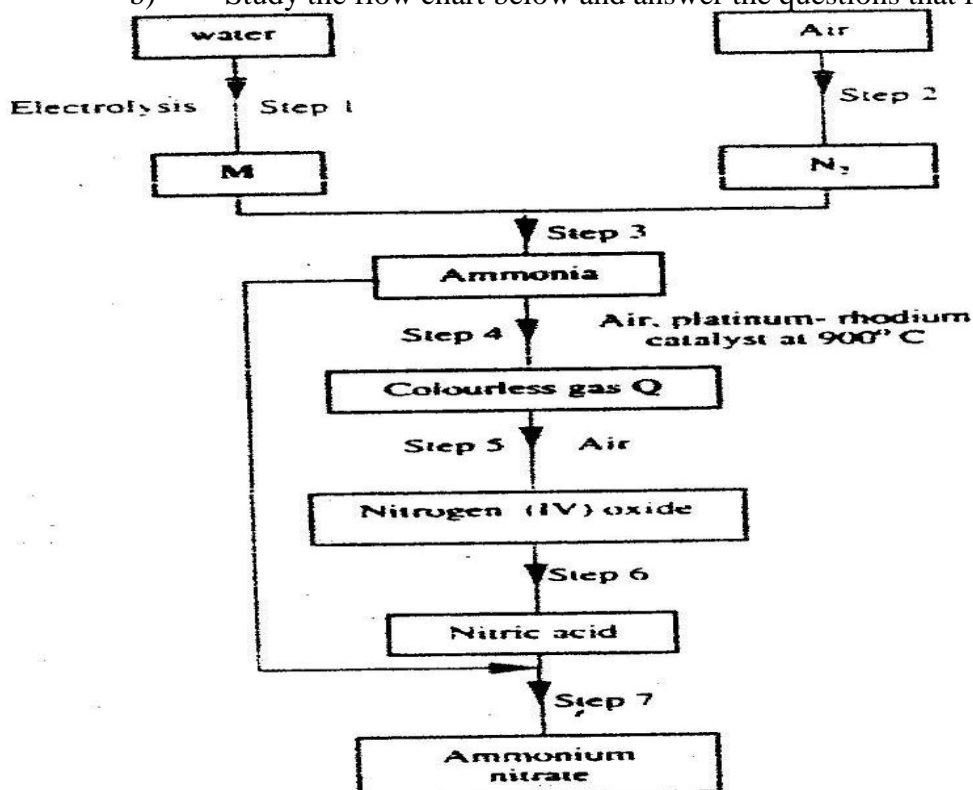

- i) Name element M.
 - ii) Why is it necessary to use excess air in step 4?
 - iii) Identify gas Q.
 - iv) Write an equation for the reaction in step 7
 - v) Give one use of ammonia nitrate.
- c) State and explain the observations that would be made if a sampler of sulphur is heated with concentrated nitric acid.
5. a) Give the name of reagent which when reacted with concentrated hydrochloric acid produce chlorine gas.
- b) A student out to prepare iron (III) chloride using the apparatus shown in the diagram below.

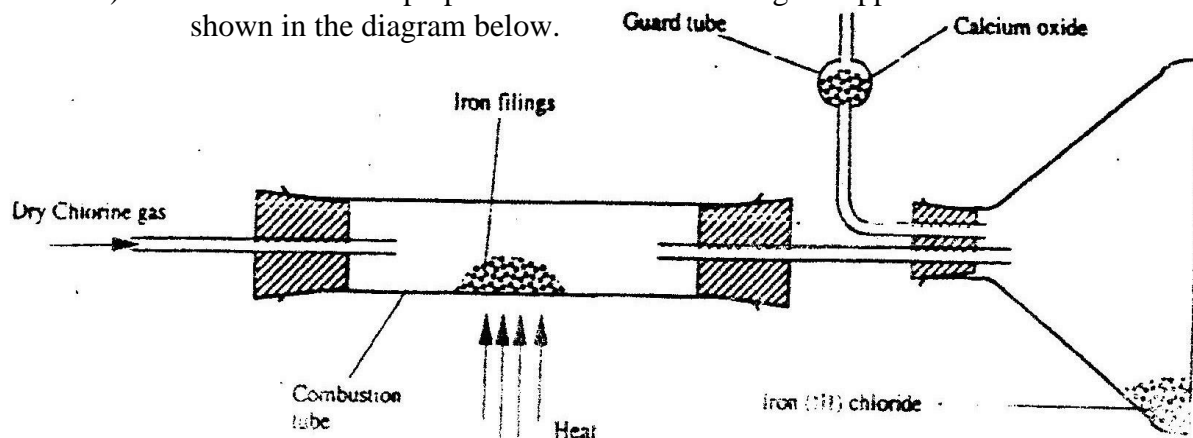

- i) Explain why:
 - I. It is necessary to pass chlorine gas through the apparatus before heating begins.
 - II. Calcium oxide would be preferred to calcium chloride in the guard tube.
- ii) What property of iron (III) chloride makes it possible to be collected as shown in the diagram?

- iii) Write an equation form one chemical reaction that took place in the guard tube.
- iv) The total mass of iron (III) chloride formed was found to be 0.5g.
Calculate the volume of chlorine gas the reacted with iron.
(Fe = 56.0, Cl = 35.5 and Molar gas volume at 298K is 24,000cm³)
- C) When hydrogen sulphide gas was passed through a solution of iron (III) chloride, the following observation were made:
- i) The colour of the solution changed from reddish – brown to green and (ii) a yellow solid was deposit .Explain these observations.
- d) State and explain the observations that would be made if a moist blue litmus paper was placed in a gas jar full of chloride gas.
6. a) Study the information in the table below and answer the questions that follow.
(The letters do not represent the actual symbols of the elements).

Ionisation Element	Electronic configuration	Energy KJ mol ⁻¹
P	2.1	519
Q	2.8.1	494
R	2.8.8.1	418

- i) What is the general name to the group in which elements P,Q and R belong?
- ii) What is meant by ionization energy? iii) Explain why elements has the highest ionization energy.
- iv) When a piece of element Q is placed on water. It melts and a hissing sound is produced as it moves on the surface of the water.
- v) Write an equation for the reaction between element Q and water.
- b) Distinguish between a strong and a weak base. Give an example of each
- c) Neutralization is one of the methods of preparing salts.
- i) What is meant by neutralization?
- ii) Describe how you would prepare crystals of sodium nitrate starting with 200cm³ of 2M sodium hydroxide.
- iii) Write an equation for the reaction that takes place when a solid sample of sodium nitrate is heated.

CHEMISTRY PAPER 233/1 K.C.S.E 2002

QUESTIONS

- Name One property of neon that makes it possible to be used in electric lamps
- Oxygen and sulphur belong to group (VI) of the periodic table. Explain why there is a big difference their (melting points of oxygen is – 216⁰C while that of sulphur is 44⁰C.
- The oxides of elements A and B have the properties shown in the table below. (the letter do not represent the actual symbols of elements)

A	B
Gaseous at room temperature	Solid at room temperature

Dissolves in water to form an acidic solution

Dissolves in water to form an alkaline solution

Give one example of elements A and B

A

B

- 4) The following two tests were carried out on chlorine water contained in two test tubes
- (c) A piece of blue flower was dropped into the first – tube. Explain why the flower was bleached
- (d) The second test- tube was corked and exposed to sunlight after a few days, it was found to contain a gas that rekindled a glowing splint. Write an equation for the reaction which produced the gas
- 5) (a) Write the electronic configuration of calcium (atomic number 20) and beryllium (atomic number 4)
- (b) Why is calcium more reactive than beryllium
- 6) When potassium nitrate is heated, it produces potassium nitrate and gas C₁
- (a) Identify gas C
- (b) Name the type of reaction undergone by the potassium nitrate
- 7) State and explain how the rate of reaction between zinc granules and steam can be increased
- 8) The apparatus shown below was set to prepare and collect hydrogen sulphide

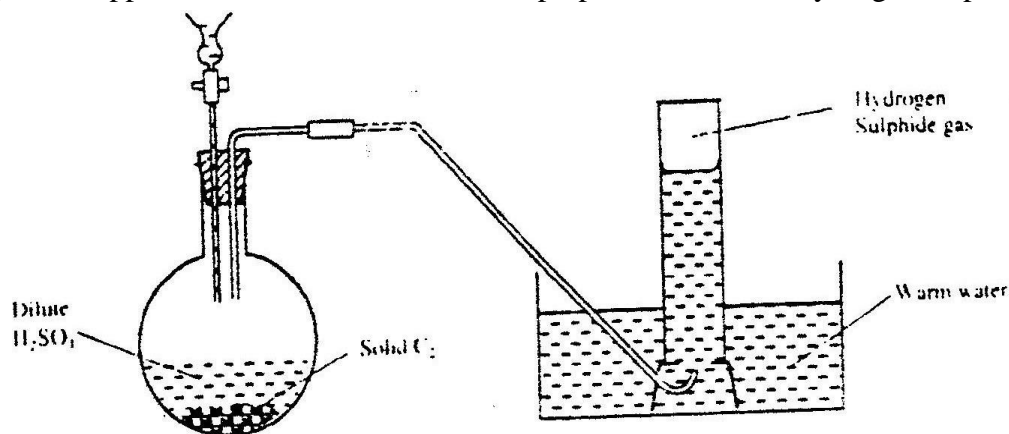

- (a) Name solid C₂
- (b) Give a reason why warm water is used
- (c) What observation would be made if hydrogen sulphide gas was bubbled into a solution of lead II nitrate?
- 9) Use the reactions given below to answer the questions that follow. The letters do not represent the actual symbols of the elements
- $$D(s) + E^{2+}(aq) \rightarrow D^{2+}(aq) + E(s)$$
- $$D(s) + 2F^+(aq) \rightarrow D^{2+}(aq) + 2F(s)$$
- $$E(s) + 2F^+(aq) \rightarrow E^{2+}(aq) + 2F(s)$$
- $$G(s) + E^{2+}(aq) \rightarrow G^{2+}(aq) + E(s)$$
- $$G(s) + D^{2+}(aq) \rightarrow \text{no reaction}$$

- (a) What name is given to the type of reaction given above?
- (b) Arrange the elements D, E, F and G in the order of their reactivity starting with the most reactive
- (c) Complete the equation below $G(s) + 2F^+(aq) \rightarrow$

10) The graph below represents a radioactive decay series for isotope H. Study it and answer the questions that follow

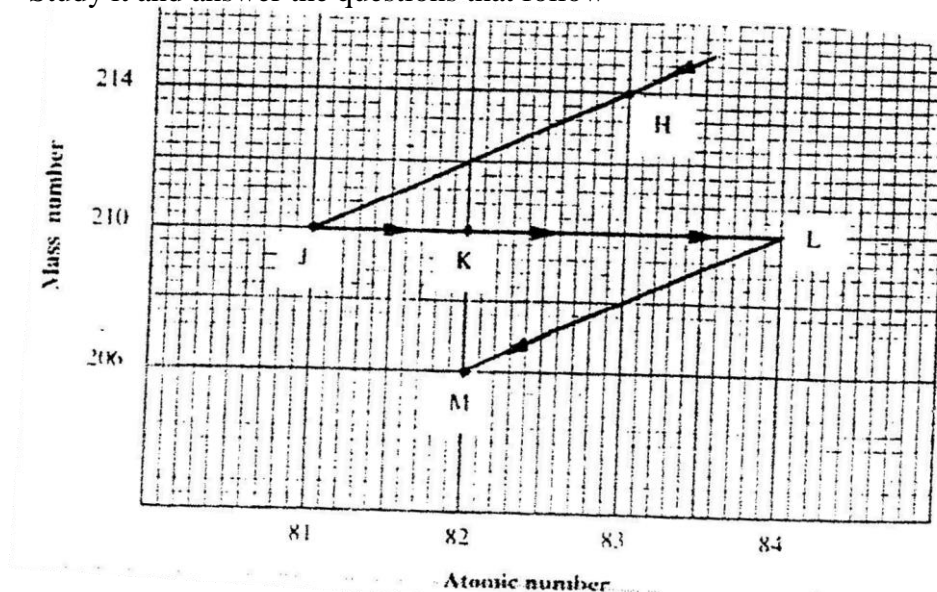

- (a) Name the type of radiation emitted when isotope H changes to isotope J.
- (b) Write an equation for the nuclear reaction that occur when isotope J changes to isotope K

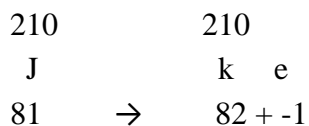

- (e) Identify a pair of isotope of an element in the decay series

- 11) In an experiment, sulphur dioxide gas was bubbled into water followed by chlorine gas. The resulting clear solution gave a white precipitate when mixed with a acidified barium chloride solution. Explain these observations
- 12) Concentrated sulphuric acid was added to iron II sulphate acidified with sulphuric acid and the mixture heated. The solution turned from pale green to yellow with evolution of brown gas. Explain these observations.
- 13) Use the equations below to answer the questions that follow $K(g) + Cl^-(g) \rightarrow KCl(s)$; $\Delta H_1 = -701 \text{ kJ mol}^{-1}$ $KCl(s) \rightarrow K^+(aq) + Cl^-(aq)$; $\Delta H_2 = +15 \text{ kJ mol}^{-1}$ (a) What is the name of ΔH_1 ?
 (b) Calculate the heat change for the process $K(g) + Cl^-(g) \rightarrow K^+(aq) + Cl^-(aq)$
- 14) Iron is extracted from its ore by the blast furnace process
 (a) Name one ore from which iron is extracted

- (b) One of the impurities in iron is removed in the form of calcium silicate. Write an equation for the reaction in which calcium silicate is produced
- 15) When carbon dioxide gas was passed through aqueous calcium hydroxide a white suspension was formed
- (a) Write an equation for the reaction that took place
- (b) State and explain the changes that would occur when carbon dioxide gas is bubbled through the white suspension
- 16) With reference to iodine, distinguish between covalent bonds and Van Der Waals forces
- 17) The structures below represents a portion of a polymer

- (a) Give the name of the polymer
- (b) Give one industrial use of the polymer

18) Describe how a solid sample of Zinc (II) carbonate can be prepared starting with zinc oxide

19) Bismuth chloride (BiCl_3) reacts with water according to the equation given below

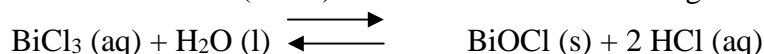

- (a) State what would happen when a few drops of dilute hydrochloric acid are added to the mixture at equilibrium
- (b) Give a reason for your answer in (a) above
- 20) The table below gives some information about the electrical conductivity and the likely bonding in substances N, P and Q. Complete the table by inserting the missing information the spaces numbered I, II and III

Substance	Likely type of bonding present	Electrical solid	Conductivity
N	Metallic	I.....	Conducts
P	II.....	Does not conduct	Conducts
Q	III	Does not conduct	Does not conduct

- 21) In an experiment 30cm^3 of 0.1 M sulphuric acid were reacted with 30cm^3 of 0.1 M sodium hydroxide
- (a) Write in equation of the reaction that took place
- (b) State the observations that were made when both and red litmus papers were dropped into the mixture
- (c) Give a reason for your answer in (a) above
- 22) The diagram below is set – up for the laboratory preparation of oxygen gas

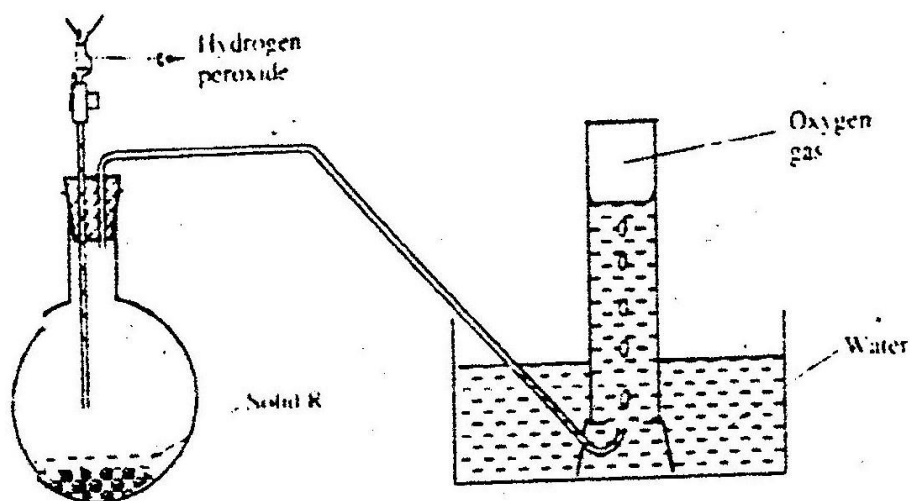

- (a) Name solid R
 (b) Write an equation for the reaction that takes place in the flask
 (c) Give one commercial use of oxygen
- 23) When excess lead nitrate solution was added to a solution containing sodium chloride, the precipitate formed was found to weigh 5.56 g. Determine the amount of sodium chloride in the solution (Pb = 207, Cl = 35.5 Na = 23)

$$\text{Pb}(\text{XO}_3)(\text{aq}) + 2\text{NaCl}(\text{aq}) \rightarrow \text{PbCl}_2 + \text{NaNO}_3(\text{aq}) \quad (1)$$
- 24) (a) Give a reason why concentrated sulphuric acid is not used to dry ammonia gas (b) Name one suitable drying agent for ammonia gas

- 25) But -2- ene undergoes hydrogenation according to the equation given below

$$\text{CH}_3\text{CH}=\text{CHCH}_3(\text{g}) + \text{H}_2(\text{g}) \rightarrow \text{CH}_3\text{CH}_2\text{CH}_2\text{CH}_3(\text{g})$$

- (a) Name the product formed when but -2 - ene reacts with hydrogen gas
 (b) State one industrial use of hydrogenation

- 26) The set –
 to
 metallic
 answer the
 follow

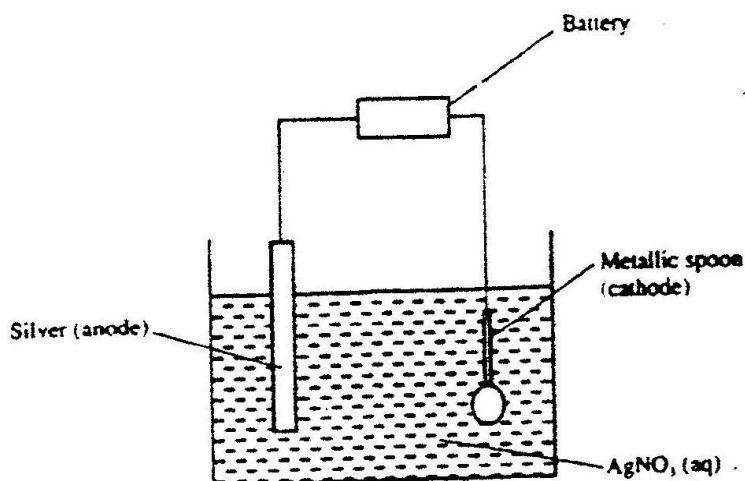

up below was used
 electroplate a
 spoon. Study it and
 questions that

- (a) Write an ionic equation for the reaction that occurred at the cathode
(b) State and explain what happened to the anode

27) The following tests were carried out on three separate portions of a colourless solution S

Tests	Observations
(i) Addition of dilute hydrochloric acid to the first portion of solution	No observable change
(ii) addition of aqueous sodium carbonate to the second portion of solution S	A white precipitate was formed
(iii) Addition of aqueous ammonia to the third portion of a solution	A white precipitate was formed which dissolved on addition of excess aqueous ammonia

- (a) From the information in test (i), name a cation, which is not present in solution S.
(b) Identify a cation, which is likely to be present in solution S
(c) Write an ionic equation for the reaction, which takes place in test (ii)

CHEMISTRY PAPER 233/2 K.C.S.E 2002
QUESTIONS

1. (a) what method can be used to separate a mixture of ethanol and propanol?
 (b) (i) Explain how a solid mixture of sulphur and sodium chloride can be separated into solid sulphur and solid chloride
 (c) The table below gives the solubilities of potassium bromide and potassium sulphate at 0°C and 40°C

Substance	Solubility g/100g water at	
	0°C	40°C
Potassium bromide	55	75
Potassium sulphate	10	12

When an aqueous mixture containing 60g of potassium and 7 g of potassium sulphate in 10g of water at 80°C was cooled to 0°C some crystals were formed

- (i) Identify the crystals
 (ii) Determine the mass of the crystals formed
 (iii) Name the method used to obtain the crystals
 (iv) Suggest one industrial application of the method named in (iii) above

2. Study the flow chart below and answer the questions follow

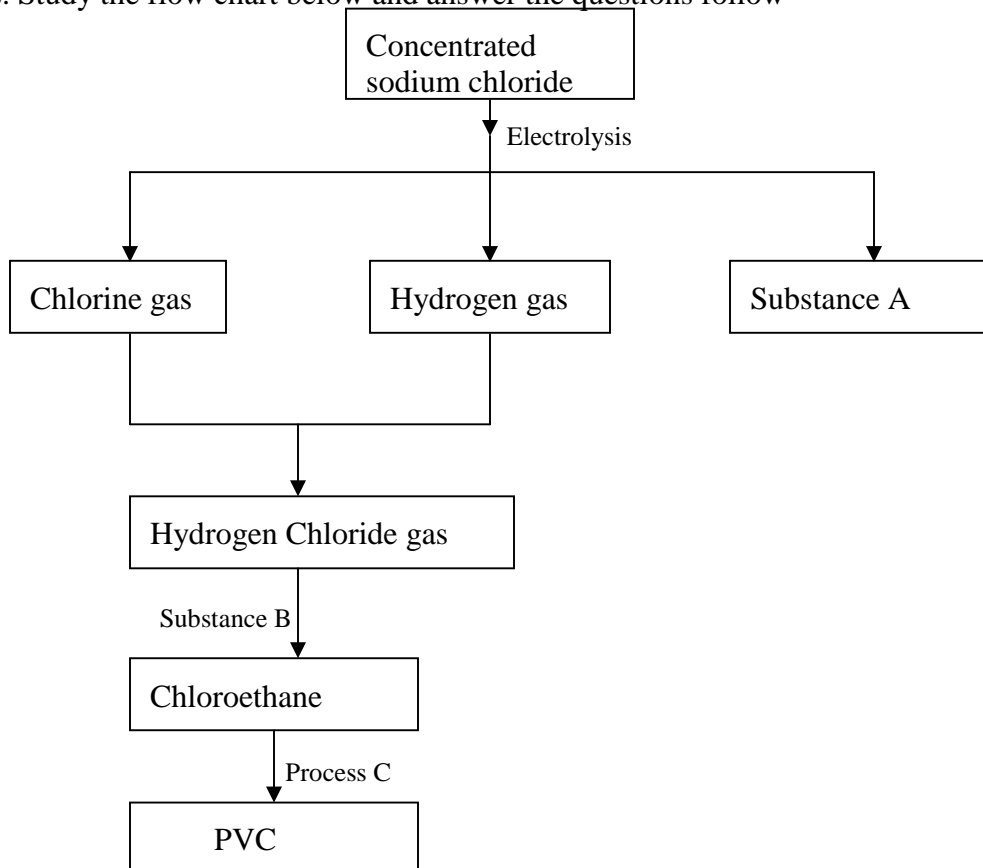

- (a) Identify substance

- (i) A
- (ii) B
- (b) Name process C
- (c) Give one use of PVC
- (d) Write an equation for the reaction in which chlorine gas is produced
- (e) State and explain the observation that would be made if chlorine gas was bubbled into an aqueous solution of sodium iodide
- (f) In the preparation of a bleaching agent (Sodium hypochlorite), Excess chlorine gas was bubbled into 15 litres of cold 2 m sodium hydroxide
- (i) Write an equation for the reaction between chlorine gas and cold dilute sodium Hydroxide
- (ii) Calculate the:
 - Number of moles of sodium hydroxide used
 - Mass in kilograms of the sodium hypochlorite produced = 1.1175

3. (a) Distinguish between exothermic and endothermic reaction (2mks)
- (b) Changes of state are either exothermic or endothermic
Name a change of state that is:
- (i) Endothermic (1 mk)
 - (ii) Exothermic (1 mk)

(c) When pure water is heated at 1 atmospheric pressure at sea level, the temperature of the water does not rise beyond 100°C. Even with continued heated. Explain this observation.

(d) Study the energy cycle diagram below and answer the questions that follow

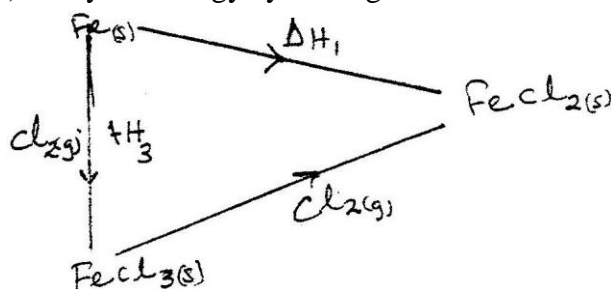

- (i) What does ΔH_1 represent?
 - (ii) Show the relationship between ΔH_1 , ΔH_2 and ΔH_3
- (e) Butane and propane are constituents of a cooking gas. Which produces more energy per mole on combustion? Explain

4. The table below gives standard electrode potentials for the metals represented by the Letters D, E, F and G. study it and answer the questions that follow.

Metals	Standard electrode potential (volts)
D	-0.13

- E -0.85
 F +0.34 G -0.76 (a) Which metal can be displaced from a solution of its salts by all the other metals in the table? Give a reason (2 mks)

(b) Metals F and G were connected to form a cell as shown in the diagram below

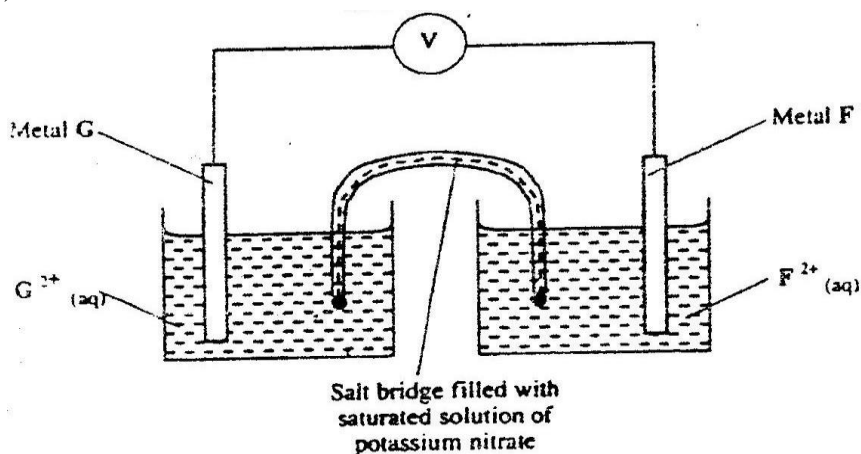

(i) Write the equation for the reactions that occur at electrodes

F

G

(ii) On the diagram, indicate with an arrow the direction in which electrons would flow on the diagram above

(ii) What is the function of the salt bridge? (1 mk)

(c) An electric current was passed through a concentrated solution of copper (II) chloride as shown in the diagram below

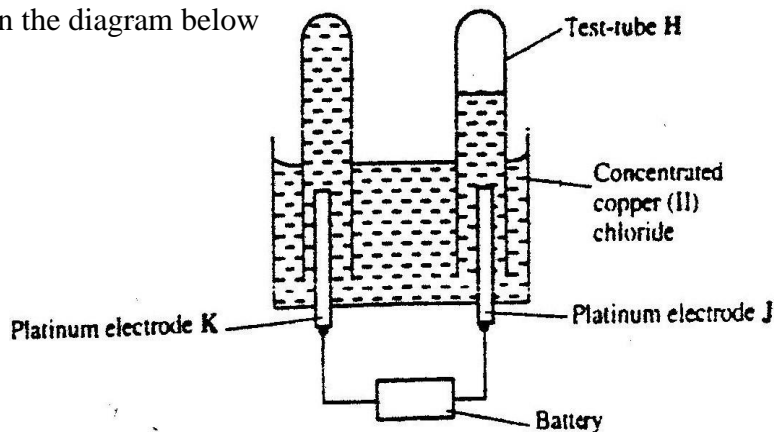

(i) Explain the observation that would be made on the electrolyte as the experiment progresses (2 mks)

(ii) After sometime, test-tube H was found to contain a mixture of two gases. Explain this observation (3 mks)

(iii) Which of the electrodes is the anode? Explain (2 mks)

5. (a) Candle wax is mainly a compound consisting of two elements.

Name the two elements

(2 mks)

(b) The set- up below was used to investigate the burning of a candle study it and answers the questions that follow

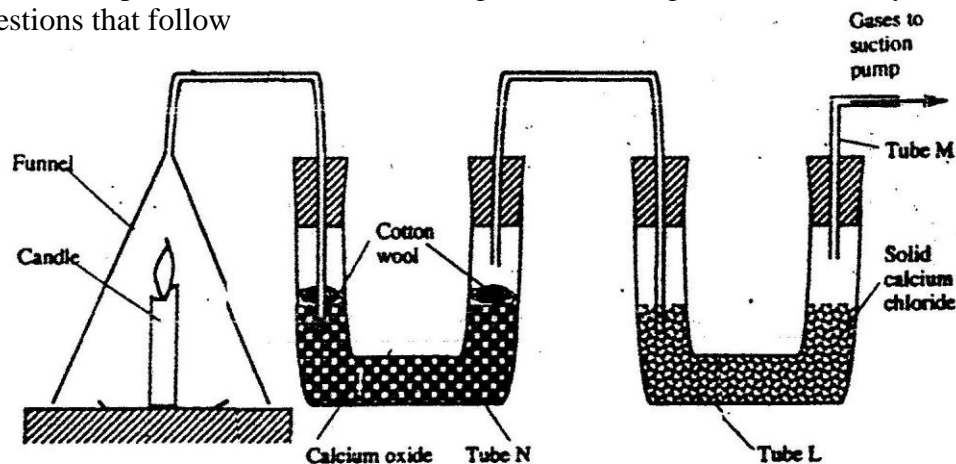

(i) What would happen to the burning candle if the pump was turned off? Give reasons

(ii) State and explain the changes in mass that are likely to occur in tube N by the end of the experiment (3 mks)

(iii) Name two gases that come out through tube M (2 mks)

(iv) Name another substance that could be used in the place of calcium oxide in tube N

6. (a) Name one ore from which copper metal is extracted (1 mk)

(b) The chart below shows a sequence of reactions starting with copper.

Study it and answer the questions that follow

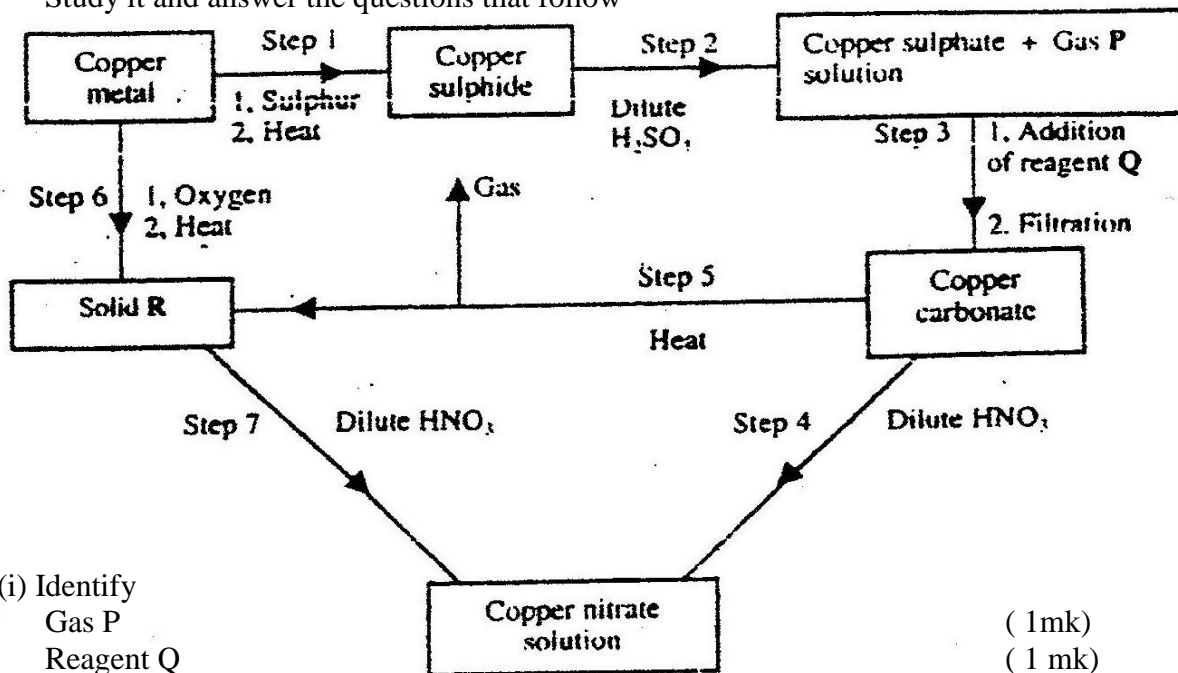

(i) Identify

Gas P

Reagent Q

Solid R

(1mk)

(1 mk)

(1 mk)

(ii) Write an equation for the reaction that takes place in step 5

(iii) State the observations made in steps 4 and 7

(2 mk)

Step 4

Step 7

(1mk)

(c) Bronze is an alloy of copper and another metal

(i) Name the other metal

(1mk)

(ii) Give one use of Bronze

(1mk)

6. (a) Write the structural formula of:

(i) Methanol

(ii) Methanoic acid

(1mk)

(b) Write the equation for the reaction between methanoic acid and aqueous sodium hydroxide

(1mk)

(c) (i) Name the product formed when methanol reacts with methanoic acid

(ii) State one condition necessary for the reaction in (c) (i) above to take place

(d) (i) Describe one chemical test that can be used to distinguish between hexane and hexane

(2 mks)

(ii) State one use of hexane

(1mk)

(iii) Hydrogen reacts with hexane to form hexane. Calculate the volume of hydrogen gas required to convert 42g of hexane to hexane at S.T.P (C=12.0, H=1.0, molar gas volume at S.T.P is = 22.4 litres)

(4 mks)

CHEMISTRY PAPER 233 / 1 K.C.S.E 2003

QUESTIONS

1. Some sodium chloride was found to be contaminated with copper (II) oxide. Describe how a sample of sodium chloride can be separated from the mixture
2. Study the information in the table and answer the questions that follow

Ion	Electronic arrangement	Ionic radius
Na ⁺	2.8	0.095
K ⁺	2.8.8	0.133
Mg ²⁺	2.8	0.065

Explain why the ionic radius of

(1mk)

K⁺ is greater than that of Na⁺

Mg²⁺ is smaller than that of Na⁺

3. Use the following equations to determine the heat evolved when aluminum metal is reacted with iron (III) oxide (3 mks)

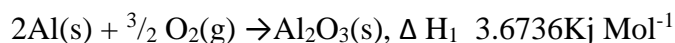

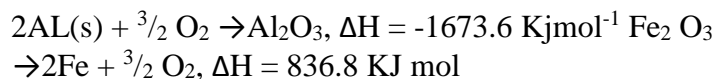
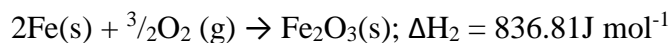

4. (a) Sulphur exists in two crystalline forms
 (b) Name one crystalline form of sulphur (1mk)
5. An atom of hydrogen can form two ions. Write two equations to show how a neutral atom of hydrogen can form two ions. In each case show the sign of the energy change involved.
 $\text{H} \rightarrow \text{H}^+ + e$ ($\frac{1}{2}$) ΔH is $+Ve$ ($\frac{1}{2}$)
 $\text{H} + e \rightarrow \text{H}^-$ ($\frac{1}{2}$) ΔH is $-Ve$ ($\frac{1}{2}$)
6. When excess dilute hydrochloric acid was added to sodium, 960cm^3 of sulphur (IV) oxide gas was produced. Calculate the mass of sodium sulphite that was used. (molar mass of sodium = 126 g and molar gas volume = 24000cm^3) (3mks)
7. In an experiment of magnesium placed into test – shown below

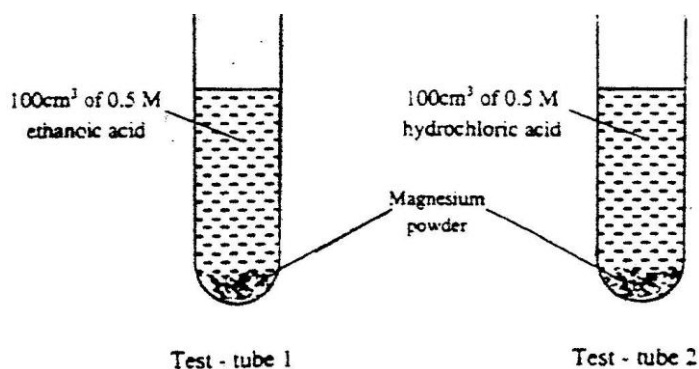

equal amounts powder were tube 1 and 2 as

Explain why the amount of hydrogen gas liberated in test – tube 2 is greater than in test-tube 1 before the reaction is complete.

8. (a) what is meant by heat of vaporization (3 mks)
 (b) The boiling points of ethanol, propanol and butanol are 78°C , 97.2° and 117°C . explain this trend (1 mk)
9. The set – up below represents the apparatus that may be used to separate a mixture of two miscible liquids C and D whose boiling points are 80°C and 110°C .

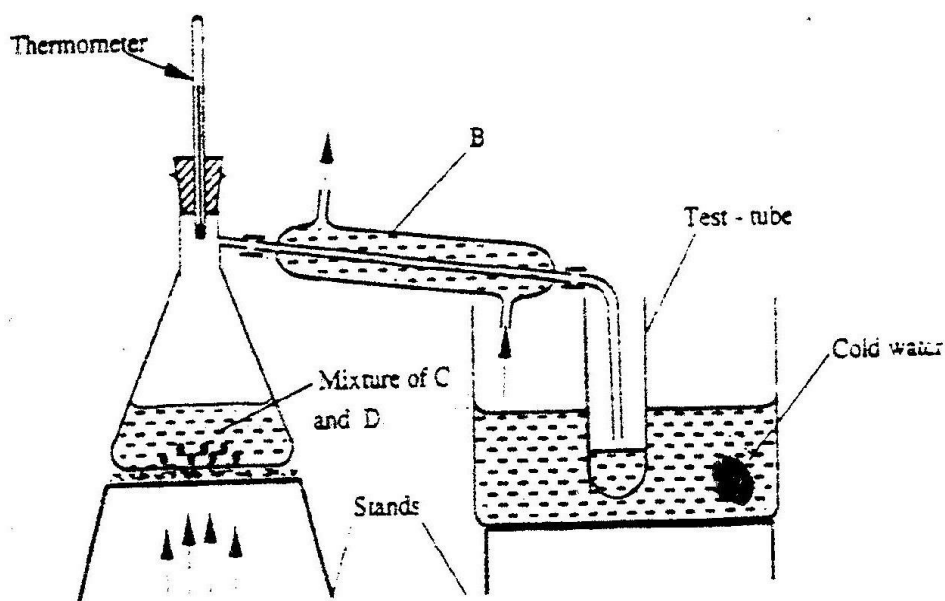

- (a) name B
- (b) What is the purpose of the thermometer (1mk)
- (c) Which liquid was collected in the test tube? (1mk)
10. An oxide of element F has the formula F_2O_5 (1mk)
- (a) Determine the oxidation state of F
- (b) In which group of the periodic-table is element F (1mk)
11. Yellow phosphorous reacts with chlorine gas to form a yellow liquid. The liquid fumes when exposed to air. Explain these observations (2 mks)
12. When steam was passed over heated charcoal as shown in the diagram below, hydrogen and carbon monoxide gases were formed
-
- (a) Write the equation for the reaction which takes place (1mk)
- (b) Name two uses of carbon monoxide gas, which are also uses of hydrogen gas (2 mks)
13. Nitrogen (II) oxide and nitrogen (IV) oxide are some of the gases released from car exhaust pipes. State how these gases affect the environment
14. A few crystals of potassium permanganate were carefully placed into water in a beaker at one spot. The beaker was left undisturbed for two hours. State and explain the observation that was made. (2mks)
15. Oleum ($H_2S_2O_7$) is an intermediate product in the industrial manufacture of sulphuric acid
- (a) How is oleum converted into sulphuric acid? (1mk)
- (b) Give one use of sulphuric acid (1mk)
16. Air was passed through several reagents as shown in the flow chart below
- Escarping

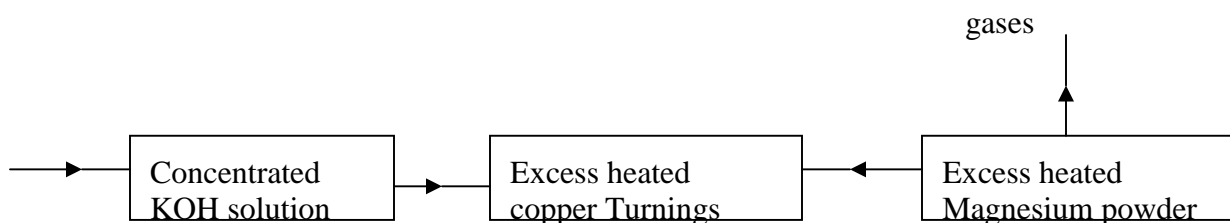

(a) Write an equation for the reaction, which takes place in chamber with magnesium powder

(b) Name one gas, which escapes from the chamber containing magnesium powder.

Give a reason for your answer.

(2mks)

17. Ammonium nitrate was gently heated and the products collected as shown in the diagram below.

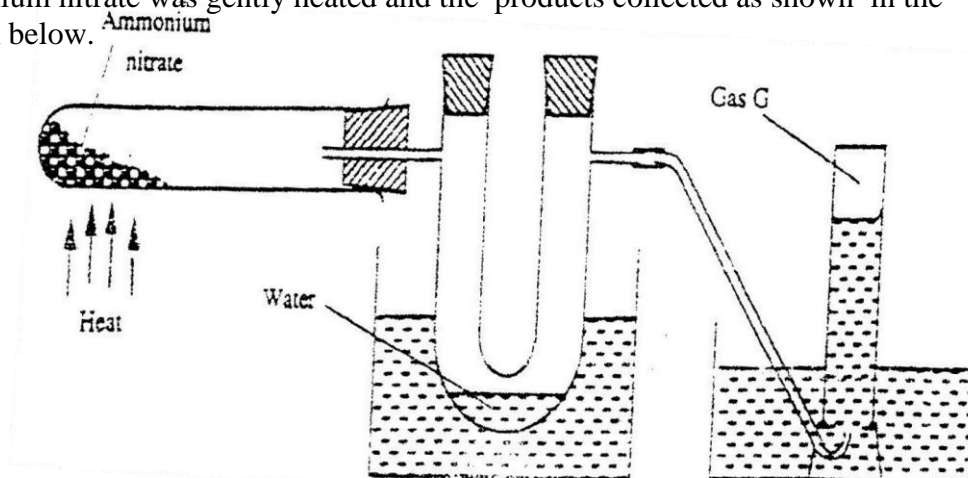

Describe one chemical and one physical method that can be used to identify gas G.

18. The table below shows the tests carried out on a sample of water and the results obtained.

	Tests	Results
I	Addition of sodium hydroxide solution	White precipitate which dissolv excess
II	Addition of excess aqueous ammonia	Colourless solution obtained
III	Addition of dilute hydrochloric acid and barium chloride	White precipitate

- Identify the anion present in the water
- Write an ionic equation for the reaction in III
- Write the formula of the complex ion formed in II

19. In the Haber process, the optimum yield of ammonia is obtained when a temperature of 450°C , a pressure of 200 atmospheres and an iron catalysts are used

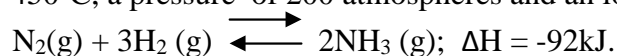

- How would the yield of ammonia be affected if the temperature was raised to 600°C ? (2mks)
- Give one use of ammonia (1mk)

20. Brass is an alloy of zinc and copper. Give one use of brass

(1mk)

21. An organic compound with the formula $C_4H_{10}O$ reacts with potassium metal to give hydrogen gas and white solid

- Write the structural formula of the compound
- To which homologous series does the compound belong?
- Write the equation for the reaction between the compound and potassium metal

(1mk) 22.

The set – up below was used to prepare hydrogen chloride a gas and react it with iron powder. Study it and answer the questions that follow.

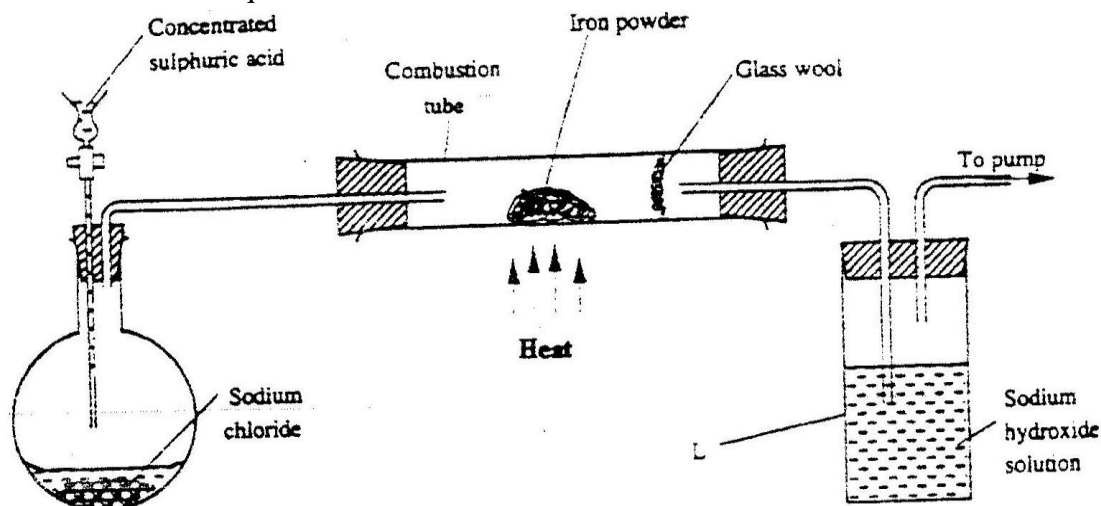

At the end of the reaction, the iron powder turned into a light green solid.

- Identify the light green solid.(1mk)
 - At the beginning of the experiment, the Ph of the solution in container L was about 14.. At the end, the pH was found to be 2. Explain(2mks)
23. a) State the observation made when excess pentane is reacted with bromine gas
- b) Name the compound formed in (a) above.(1mk)
24. Explain why the reactivity of group (vii) elements decreases down the group
25. The graph below shows the behaviour of a fixed mass of a gas at constant

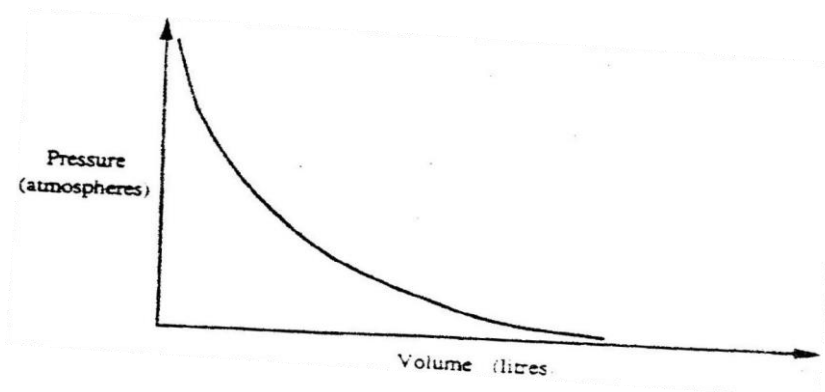

temperature.

- a) What is the relationship between the volume and the pressure of the gas?
 b) 3 litres of oxygen gas at one atmosphere pressure were compressed to two atmospheres at constant temperature. Calculate the volume occupied by the oxygen gas (2mks)

26. Ammonia gas was passed into water as shown below

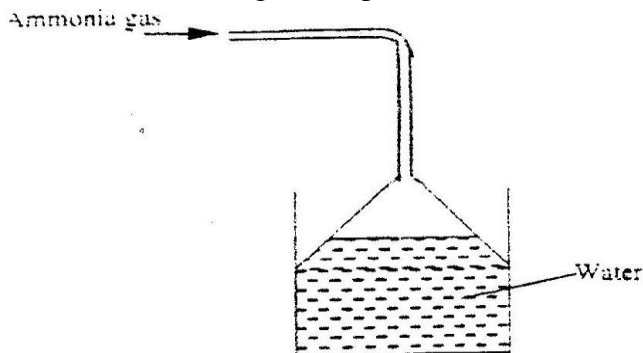

- a) What is the relationship between the volume and the pressure of the gas?(1mk)
 b) 3 litres of oxygen gas at one atmosphere pressure were compressed to two atmospheres at constant temperature. Calculate the volume occupied by the oxygen gas. (2mks)
27. During purification of copper by electrolysis, 1.48g of copper were deposited when current was passed through aqueous copper(II) sulphate for $2\frac{1}{2}$ hours. Calculate (CU = 63.5, 1 Faraday = 96,500C).

CHEMISTRY PAPER 233/2 K.C.S.E 2003

QUESTIONS

1. a) The chart below is an outline of part of the periodic table.

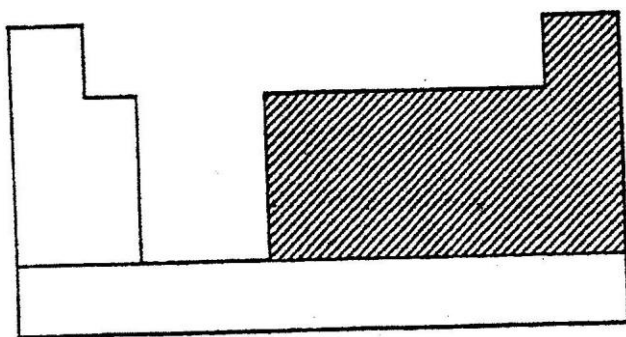

With the help of vertical and horizontal lines, indicate the direction of increasing metallic nature of the elements. (2mks)

Which types of elements are represented in the shaded area? (1mk)

- b) i) Element A is the same group of the periodic table as chlorine.
 Write the formula of the compound formed when A reacts with potassium metal.(1mk)
 ii) What type of bonding exists in the compound formed in (b) (i) above?
 Give a reason for your answers. (3mks)

- c) Starting with aqueous magnesium sulphate, describe how you would obtain a sample of magnesium oxide. (3mks)
- d) Write two ionic equations to show that aluminium hydroxide is amphoteric (2mk)

2. a) The diagram below is a cross-section of a dry cell. Study it and answer the questions that follow.

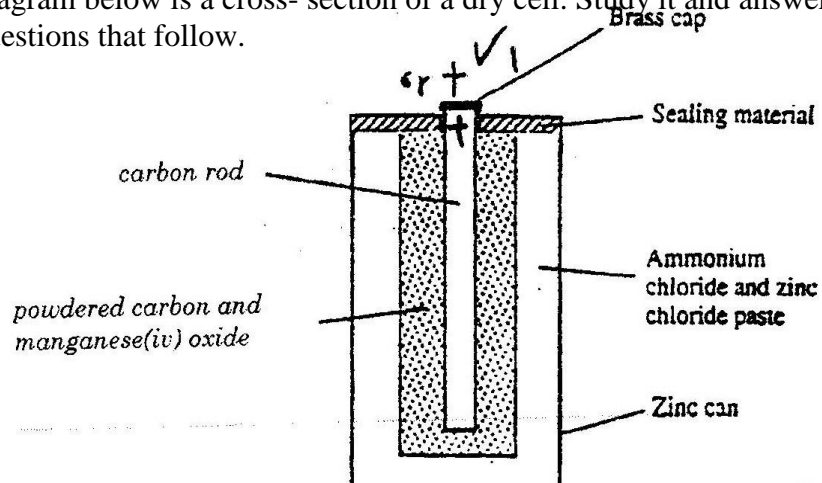

- i) On the diagram, show with a (+) sign the positive terminal
 ii) Write the equation for the reaction in which electrons are produced
 iii) The zinc can is lined with ammonium chloride and zinc chloride paste.
 iv) Give one advantage and one disadvantage of dry cells.

- b) The set-up below was used to (electrolyse roller lead (II) iodide).

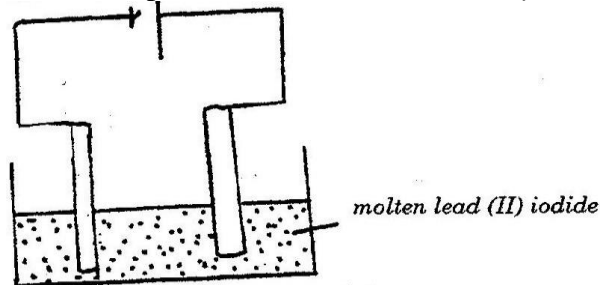

- i) State the observation that was made at the anode during the electrolysis.
 Give a reason for your answer.(2mk)
- ii) A current of 0.5 A was passed for two hours. Calculate the mass of lead that was deposited (pb = 1F = 9,500C) (3mks)

3. a) State two differences between chemical and nuclear reactions(2mks)

- b) Below is a radioactive decay series starting from $^{214}_{83}\text{Bi}$ and ending at $^{206}_{82}\text{Pb}$. Study it and answer the question that follows.

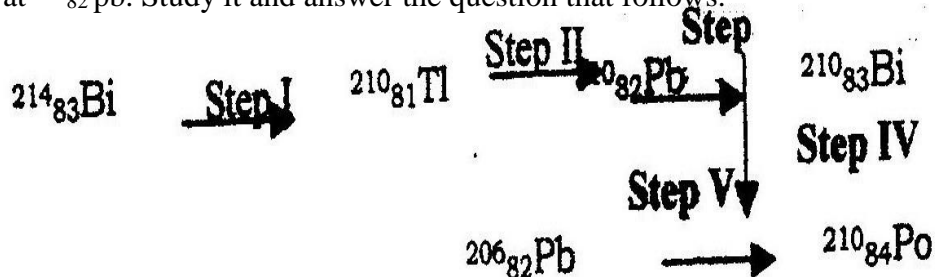

- i) Identify the particles emitted in steps I and III (2mks)

I
II

- ii) Write the nuclear equation for the reaction which takes place in step V(1mk)

The table below give the percentages of a radioactive isotope of Bismuth that remains after decaying at different times.

Time (min)	0	6	12	22	38	62	100
Percentage of Bismuth	100	81	65	46	29	12	3

- i) On the grid provided, plot a graph of the percentage of Bismuth remaining (Vertical axis) against time.

- ii) Using the graph, determine the:

I. Half – life of the Bismuth isotope

II. Original mass of the Bismuth isotope given that the mass that remained after 70 minutes was 0.16g (2mks)

- d) Give one use of radioactive isotopes in medicine (1mk)

4. Excess marble chips (calcium carbonate) was put in a beaker containing 100cm³ of dilute hydrochloric acid. The beaker was then placed on a balance and the total loss in mass recorded after every two minutes as shown in the table below.

Time(min)	0	2	4	6	8	10
Total loss in mass (g)	0	1.8	2.45	2.95	3.2	3.3

- a) Why was there a loss in mass? (1mk)

- b) Calculate the average rate of loss in mass between:

- i) 0 and 2 minutes (1mk) ii) 6 and 8 minutes (1mk)

- iii) Explain the difference in the average rates of reaction in (b) (i) and (ii) above (2mks)

- c) Write the equation for the reaction which takes place in the beaker

- d) State three ways in which the rate of the reaction above could be increased(3mk)

- e) The solution in the beaker was evaporated to dryness what would happen if the open beaker and its contents were left in the laboratory overnight.(2mks)

- f) Finally some water was added to the contents of the beaker.

When aqueous sodium sulphate was added to the contents of the beaker, a white precipitate was formed. (1mk)

- i) Identify the white precipitate

- ii) State one use of the substance identified in (f) (i) above (1mk)

5. The basic raw material for extraction of aluminium is bauxite

- a) Name the method that is used to extract aluminium from bauxite

- b) Write the chemical formula of the major component of bauxite

- c) i) Name two major impurities in bauxite (2mks) ii) Explain how the impurities in bauxite are removed (3mks) d) Cryolite is used in the extraction of aluminium from bauxite.

State its function (1mk)

- f) Aluminium is a reactive metal yet utensils made of aluminium do not corrode easily. Explain this observation (2mks)
6. The set – up below was used to prepare hydrogen gas

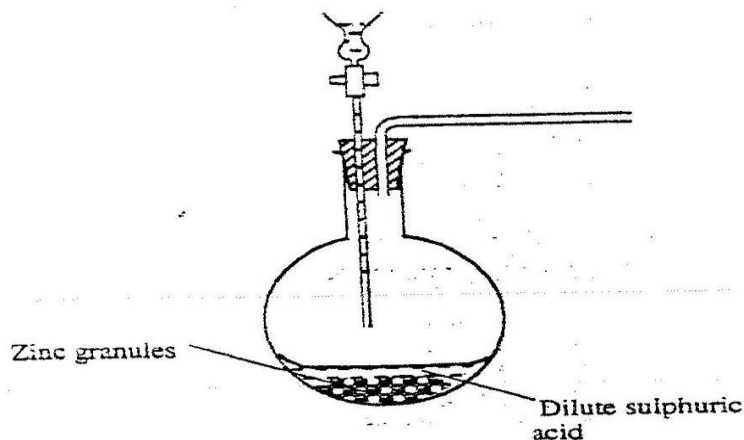

- a) Complete the diagram to show how a dry sample of hydrogen gas can be collected (3mks)
- b) Write an equation for the reaction, which takes place when hydrogen gas burns in air. (1mk)
- c) i) 1.2 litres of hydrogen gas produced at room temperature and pressure when 3.27g of zinc was used. Determine the relative atomic mass of zinc. (Molar gas volume is 24 litres) 4mks
- d) State two industrial uses of hydrogen gas.

7. a) State how burning can be used to distinguish between ethane and ethyne. Explain your answer. (3mks)
- b) Draw the structural formula of the third member of the homologous series of ethyne.
- c) The flow chart below shows a series of reactions starting with ethanol.

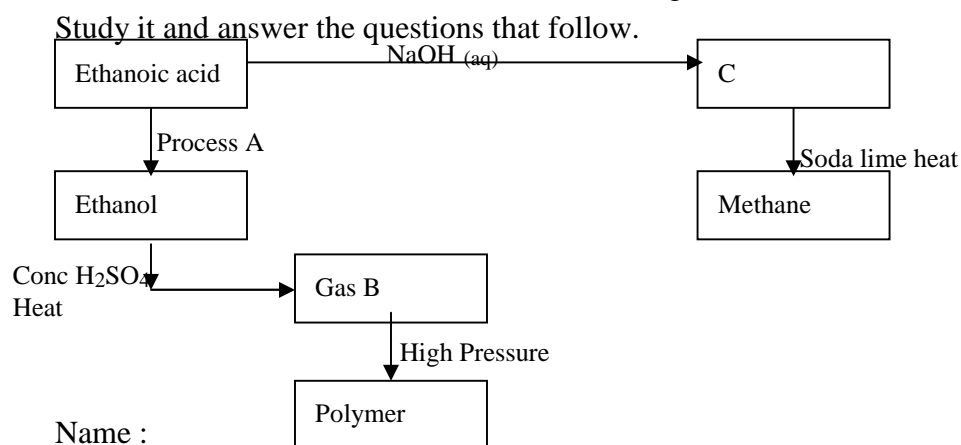

- i) Name :
- I. Process A
 - II. Substances B and C
- B
- C
- ii) Write the equation for the combustion of ethanol (1mks) iii)
- Explain why it is necessary to use high pressure to change gas B
- into the polymer (1mk) iv)
- State one use of methane (1mk)

K.C.S.E 2004 CHEMISTRY PAPER 233/1

QUESTIONS

- When a candle was burnt completely. The total mass product was found to be greater than the original mass of the candle. Explain
- Ammonium nitrite was heated as shown in the set-up below (2 marks)

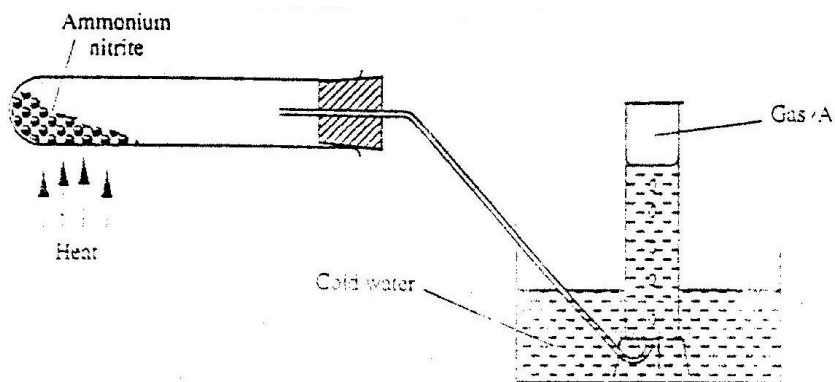

- Identify gas a.
 - State explain precaution that must be taken before heating and dropping.
- The table below the first ionization energies of elements B and C.

Element	Ionisation energy KJ mol^{-1}
B	494
C	736

What do these values suggest about the reactivity of B compared to that of C? Explain (2mks)

- Dilute solid sodium shown in the

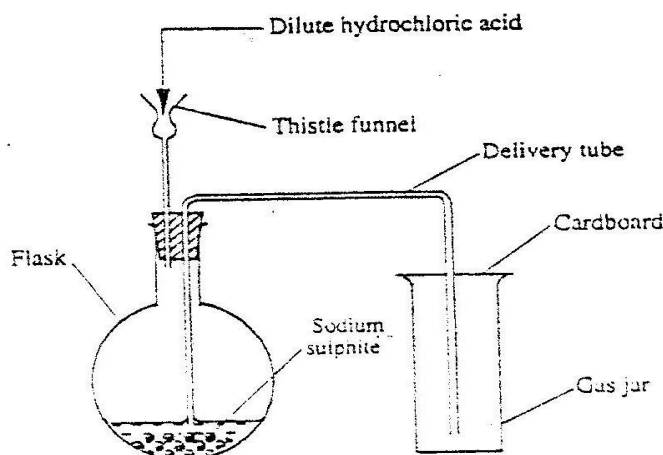

hydrochloric acid and sulphite were reacted as set-up below

- Name the gas produced in the flask (2mks)
- Give two reasons why no gas was collected in the gas jar. (2mks) 5. Copper(II) sulphate reacts with barium chloride according to the equation below.

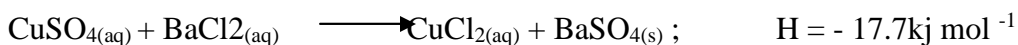

Calculate the temperature change when 900cm³ of m copper (II) sulphate were added to 600cm³ of 1M Barium (II) chloride.

6. Both diamond and graphite have giant atomic structures. Explain why diamond is hard while graphite is soft. (3mks)
7. Nitrogen forms many compounds in which its oxidation state varies.
 - a) What is meant by oxidation state? (1mk)
 - b) What is the oxidation state of nitrogen in Mg₃N₂ (1mk)
8. When wood is burnt, a grey powder called ash remains. The ash is stirred with water and filtered, a colourless solution is obtained.
 - a) What is the main component of the colourless solution?(1mk)
 - b) Explain your answer in (a) above(2mks)
9. Study the information in the table below and answer the questions that follows.

Alcohol	Heat of combustion on KJ mol ⁻¹
Methanol	715
Ethanol	1371
Propanol	2010
Butanol	2673

Give a reason why the difference in the molar heats of combustion between successive alcohols are close. (3mks)

10. Explain why a high temperature is required for nitrogen of react with oxgen(1mk)
11. Study the flow chart below and answer the questions that follow.

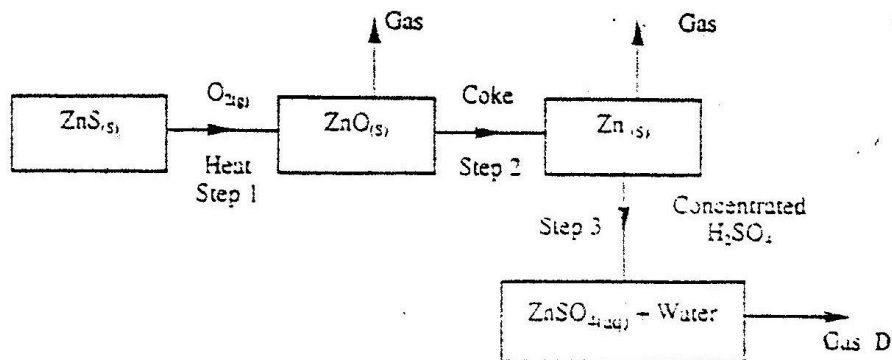

- a) State the condition necessary for the reaction in step 2 to occur (1mk)
- b) Name:
 - i) Gas D (1mk)
 - ii) One use of zinc (1mk)
12. Starting with aluminium sulphate, describe how a solid sample of aluminium hydroxide could be prepared. (3mks)
13. a) What is the name given to the smallest repeating unit of a polymer.(1mk)
 - b) Draw the structure of the smallest repeating unit of a polyvinyl chloride (1mk)
14. When X cm³ of a solution of 0.5m magnesium carbonate was 8.4g.

- a) Write the ionic equation for the reaction that took place(1mk)
- b) Calculate the value of X. (C = 12.0, Mg 24.0; 016.0 (2mks)
15. In an experiment, a student put equal volumes of mixtures of ethanoic acid in water and ethanoic acid in hexane in two test – tubes as shown below. In each test tube, equal amounts of solid sodium hydrogen carbonate were added.

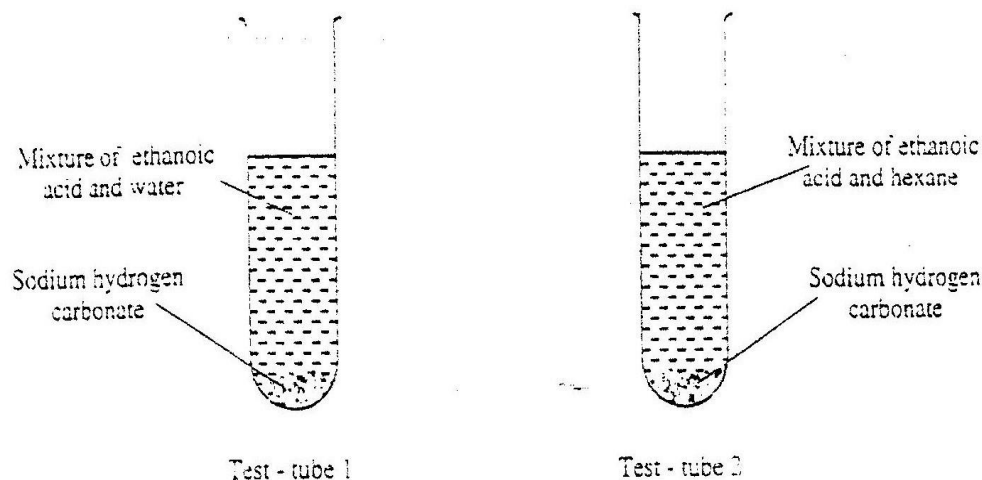

- a) State the observation which was made in each test – tube(1mk)
- Test tube 1
- Test tube 2
- b) Explain the observation in (a) above (2mks)
16. Four metal F,G,H and J were each separately added to cold water, and steam. The table below is a summary of the observations made and the formulae of the hydroxides formed.

Metal	Cold water	Hot water	Steam	Formula of Hydroxide
F	Reacts slowly	Reacts fast	Reacts very fast	F(OH) ₂
G	No reaction	No reaction	No reaction	-
H	Fast	Reacts very fast	Reacts explosively	HOH
J	No reaction	Reacts slowly	Reacts fast	J(OH) ₂

- a) Which two elements are likely to be in the same group of the periodic table?
- b) Arrange the metals in the order of their reactivity starting with the most reactive (2mks)
17. Name the organic compound formed when $\text{CH}_3\text{CH}_2\text{CH}_2\text{CH}_2\text{CH}_2\text{OH}$ is reacted with concentrate sulphuric acid at 170°C (1mk)

18. Carbon monoxide gas passed over heated Iron (III) as shown in the diagram below.

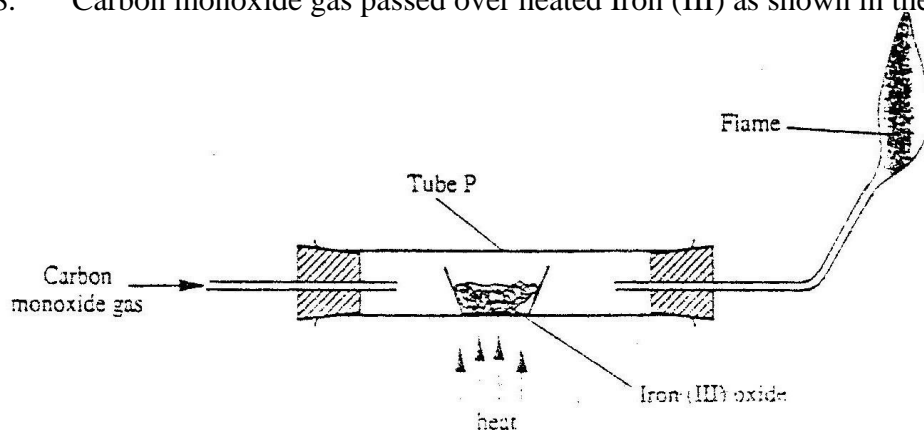

- a) Give the observation made in tube P. (1mk)
 b) Write the equation for the reaction which takes place in tube P. (1mk)
19. A strip of metal Q was dipped into a solution of copper (II) sulphate and allowed to stand overnight. Give that:

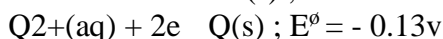

- a) State the observations which were made (2mks)
 b) Give a reason for your answer in 19 (a) above. (1mk)
20. State two factors which determine the stability of an isotope. (2mks)
21. The react between a piece of magnesium ribbon with excess 2m hydrochloric acid was investigated at 25°C by measuring the volume of hydrogen gas produced as the reaction progressed. The sketch below represents the graph that was obtained.

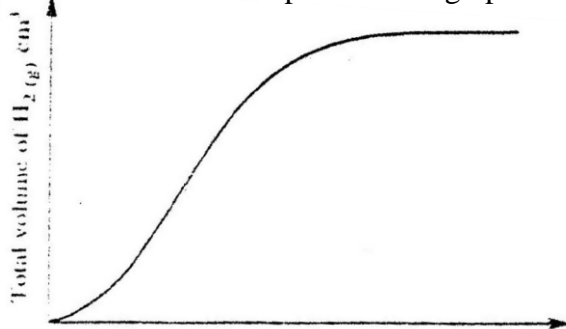

- a) Name one piece of apparatus that may be used to measure the volume of hydrogen gas produced.
 b) On the same diagram, sketch the curve that would be obtained if the experiment when excess chlorine gas was bubbled into hot concentrated sodium hydroxide, the following reaction occurred.



In which product did chlorine undergo oxidation? Explain (3mks)

23. 1cm³ of soap was added to two test – tubes each containing water obtained from different sources. The lather produced in each test tube is represented as shown in the diagram below.

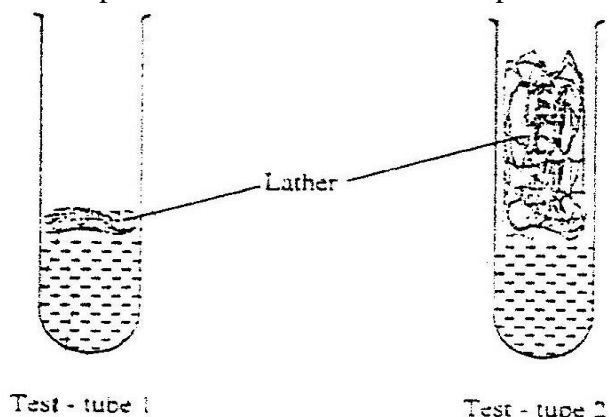

Explain why there is more lather in test – tube 2 than in test – tube 1.(3mks)

24. Carbon dioxide can be dissolved in water under pressure to make an acidic solution.
- What is meant by an acidic solution?(1mk)
 - aqueous lead (II) nitrate reacts with the acidic solution to form a precipitate.

Write an ionic equation for the reaction.(1mk)

Below is a sketch of a reaction profile.

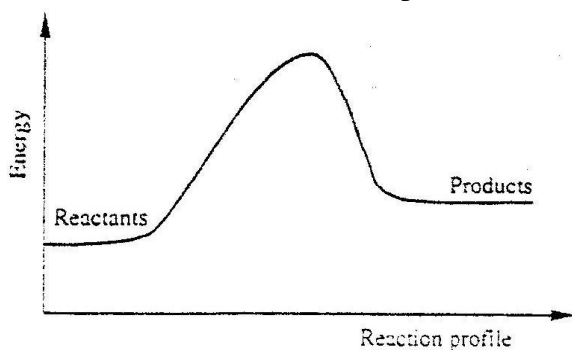

- On the diagram, show the heat of reaction, H.(1mk)
 - State and explain the type of reaction represented by the profile(2mks)
26. The diagram below represents the set – up that was used to study the effect of an electric current on pure water and dilute sulphuric acid.

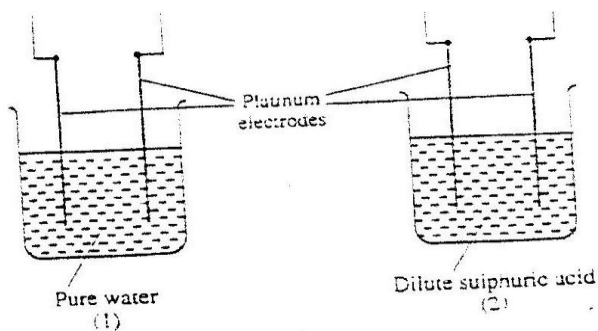

State and explain the observation made when each experiment was started.(3mks)

27. A piece of chromatography paper was spotted with coloured inks obtained from pens labeled 1 to 6. The diagram below shows the spots after the chromatogram was developed.

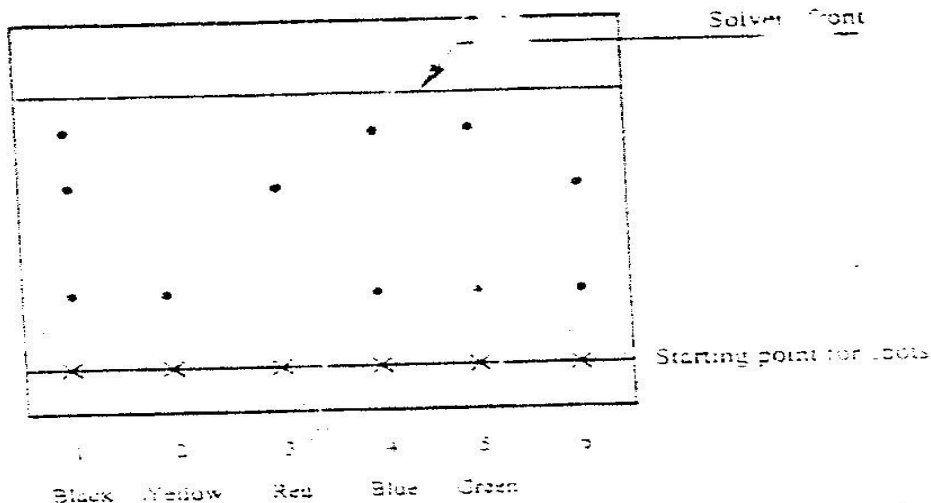

- Which two pens contained in the same pigment?(1mks)
- Which pens contained only one pigment(1mk)
- According to the chromatogram, which pigments are present in the ink of pen number 6.(1mk)

CHEMISTRY PAPER 233/2.

K.C.S.E 2004

1. a) The table below shows properties of chlorine, bromine and iodine.

El	mFormula	Colour and state room temperature	Solubility
Chlorine	Cl ₂	i).....	Soluble
Bromine	Br ₂	Brown liquid	ii).....
Iodine	I ₂	iii)	Slight soluble

Complete the table by giving the missing information in (i),(ii) and (iii) (3mks)

- Chlorine gas is prepared by reacting concentrated hydrochloric acids with manganese (iv) oxide.
 - Write the equation for reaction between concentrated hydrochloric acid and manganese (iv) oxide. (1mk)
 - What is the role of manganese (Iv) oxide in this reaction (1mks)
- Iron (II) chloride reacts with chlorine gas to form substance E.(1mk)
Identify substance E
 - During the reaction in c(i) above,6.30g of iron chloride were converted to 8.06 of substance E. Calculate the volume of chlorine used.
(Cl = 35.5, Molar gas volume at room temperature = 24000cm³, Fe =56 (mks)
- Draw and name the structure of the compound formed when excess chlorine gas is reacted with ethane gas. (2marks)
- Give the industrial use of chlorine (1 mk)

2. a) The set-up below was used to collect gas F, produced by the reaction between water and calcium metal.

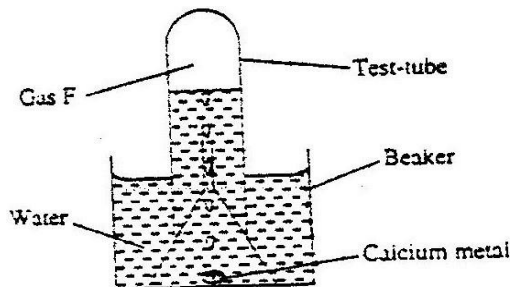

- (i) Name gas f
 (ii) At the end of the experiment, the solution in the beaker was found to be a weak base. Explain why the solution is a weak base. (2 marks)
 (iii) Give one laboratory use of the solution formed in a beaker. (1 mark)
- b) The scheme below shows some reactions starting with calcium oxide. Study it and answer the questions that follow.

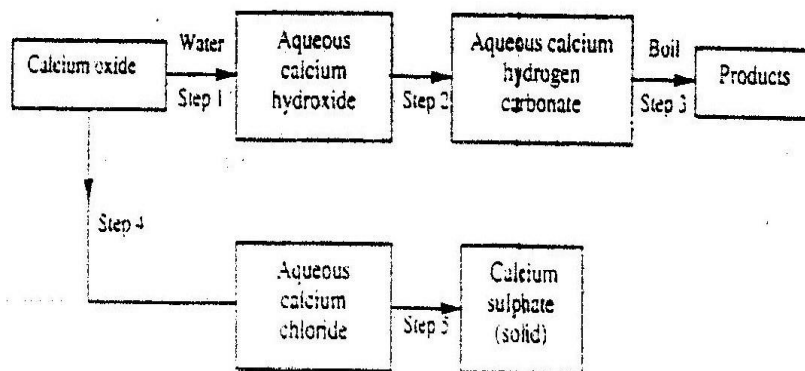

- (i) Name the reagents used in steps 2 and 4 (2marks)
 Step 2
 Step 4
- (ii) write an equation for the reaction in step 3. (1 mk)
- (iii) Describe how a solid sample of anhydrous calcium sulphate is obtained in Step 5
3. a) The diagram below illustrates how sulphur/extracted by the Frisch process.

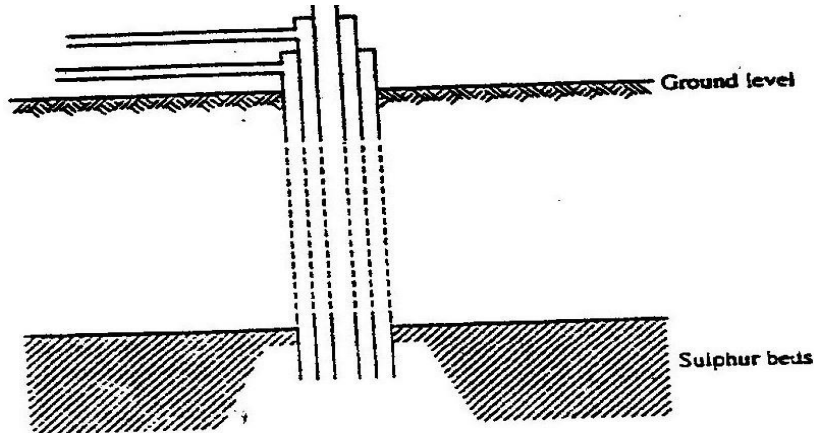

Label the pipe through which superheated water is pumped in (1mk)

- b. The equation below shows the oxidation of sulphur dioxide to sulphur trioxide in the contact process.



- (i) Name one catalyst for this reaction (1 mark)
- (ii) State and explain the effect on the yield of sulphur trioxide when:
- I The temperature increased (2mks)
- II The amount of oxygen is increased (2mks)
- (iii) Describe how sulphur trioxide is converted to sulphuric acid in the contact process. (2 marks)
- (c) State two disadvantages of having sulphur dioxide in the environment (2mks)
- (d) Ammonia sulphate is a fertilizer produced by passing ammonia gas into concentrated sulphuric acid.
- (i) Write the equation for the reaction (1mk)
- (ii) Calculate the mass in Kg of sulphuric acid required to produce 25kg of the fertilizer (S= 32.0; O= 16.0; N = 1.0)
4. a) at 25°C, 50g of potassium were added to 100g of water to make a saturated solution. What is meant by a saturated solution? (1 mk)
- b) The table below gives the solubilities of potassium nitrate at different temperatures.

Temperature °C	12	20	28	36	44	52
Solubility g/100g C water	22	31	42	55	70	90

- (i) Plot graph of the solubility of potassium nitrate (vertical axis) against temperature (3 marks)
- (ii) Using the graph:
- I Determine the solubility of potassium nitrate at 15°C
- II Determine the mass of potassium nitrate that remained undissolved given that 80g of potassium nitrate were added to 100cm³ of water and warmed to 40°C.
- c) Determine the molar concentration of potassium nitrate at 15°C (3mks)
(Assume there is no change in density of water at this temperature)
(K = 39.0; N= 14.0; O = 16.0)
5. The flow chart below shows some reactions starting with lead (II) nitrate. Study it and

answer the questions that follow.

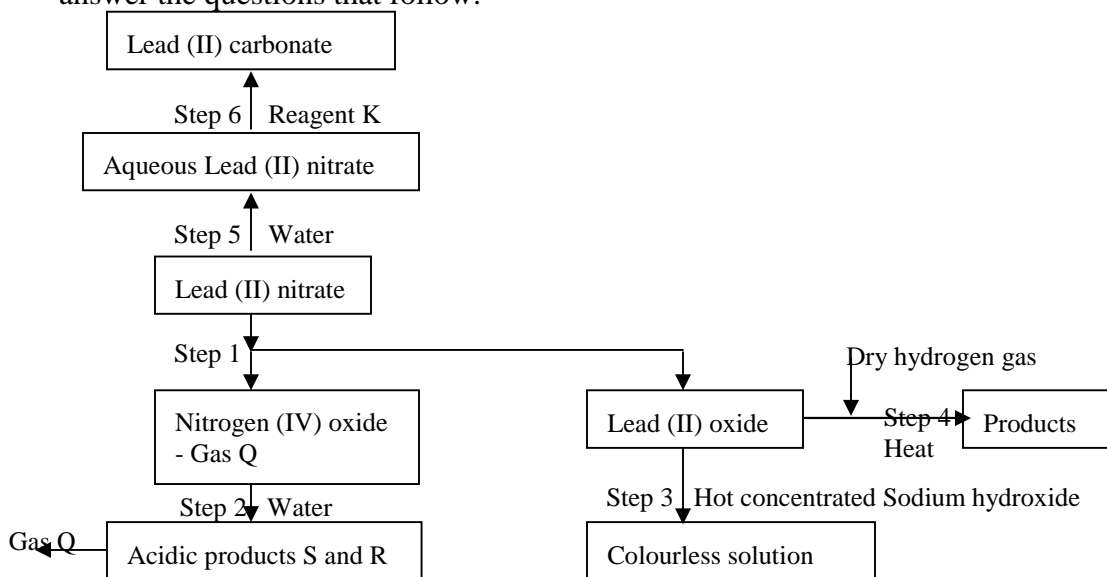

- (i) State the condition necessary in step 1.
- (ii) Identify:
 - I Reagent K
 - II Gas q
 - III Acidic products S and R
- (iii) Write:
 - I The formula of the complex ion formed in step 3. (1mk)
 - II The equation of the reaction in step 4 (1mk)
- b) The use of materials made of lead in roofing and in water pipes is being discouraged. State:
 - (i) Two reasons why these materials have been used in the past. (2mks)
 - (ii) One reason why their use is being discouraged
 - (c) (i) The reaction between lead (II) nitrate and concentrated sulphuric acid starts but stops immediately. Explain (2mks)
6. a) Crude oil is a source of many compounds that contain carbon and hydrogen only.
 - (i) Name the processes used to separate the components of crude oil (1mk)
 - (ii) On what two physical properties of the above components does the separation depend? (2mks)
- b) Under certain conditions, hexane can be converted to two products. The formula of one of the products is C_3H_6
 - (i) Write the formula of the other product (1mk)
 - (ii) Describe a simple chemical reaction to show the difference between the two products formed in (b) above. (2mks)
- c) Ethane, C_2H_6 is another compound found in crude oil. One mole of ethane was reacted with one mole of hydrogen chloride gas and a product p_1 was formed. p_1 was then reacted with excess hydrogen gas to form p_2 . Draw the structures p_1 and p_2 .
- d) The set-up below was used to prepare and collect ethane gas. Study it and answer the questions that follow.

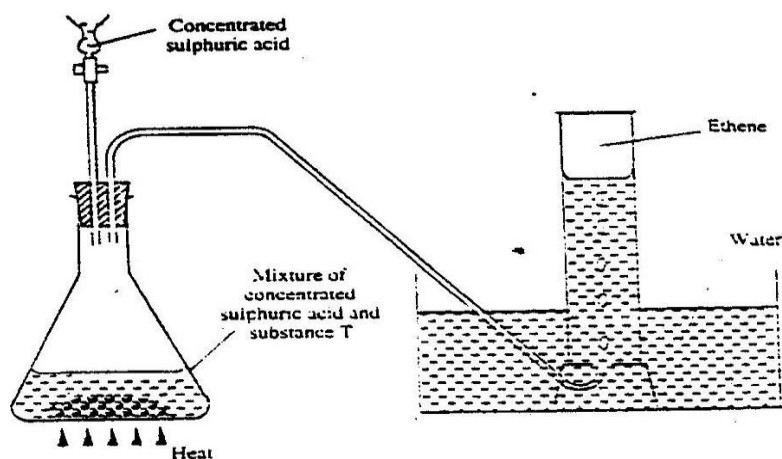

- (i) Name the substance T
- (ii) Give the property of ethane that allows it to be collected as shown in the set up.
- e) One of the reactions undergone by ethane is addition polymerization. Give the name of the polymer and one disadvantage of the polymer it forms. (2 marks)

Name the polymer.

Disadvantage of the polymer

7. (a) Brine usually contains soluble calcium and magnesium salts. Explain how sodium carbonate is used to purify brine. (2mks)
- b) The diagram below represents a diaphragm cell used to electrolyse pure brine

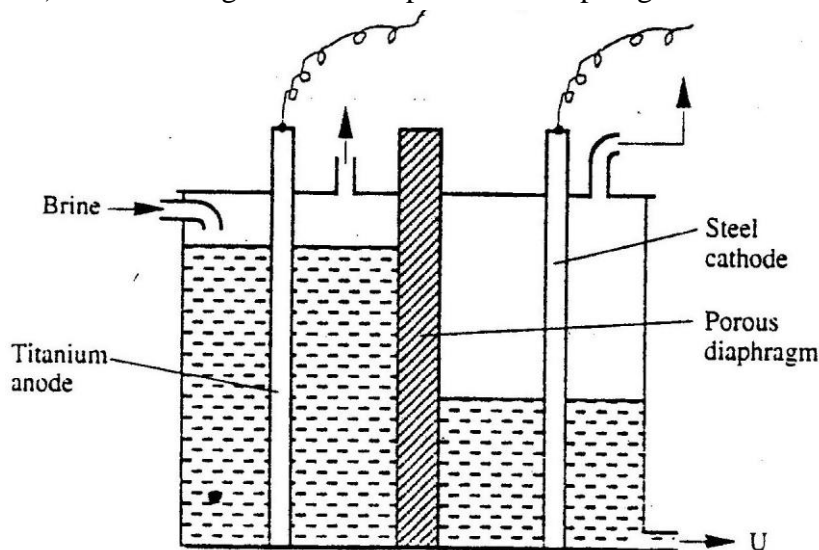

- (i) Write the equations for the reactions that take place at
 - I Cathode (1mk)
 - II Anode (1mk)
 ii) Name:
 - I Product at U (1mk)
 - II Another material that can be used instead of titanium (1mk)
 - III The impurity present in the product at U
 iii) State two functions of the diaphragm (2mks)
- c) Give one industrial use of the product at U. (1 mk)

CHEMISTRY PAPER 233/1 K.C.S.E 2005

QUESTIONS

1. State one use of sodium hydrogen carbonate. (1 mark)
2. Calcium oxide can be used to dry ammonia gas. (2 mark)
 - a) Explain why calcium oxide is not used to dry hydrogen chloride gas (2 mark)
 - b) Name one drying agent for hydrogen chloride gas
3. The set-up below was used to demonstrate the effect of heat on hard water

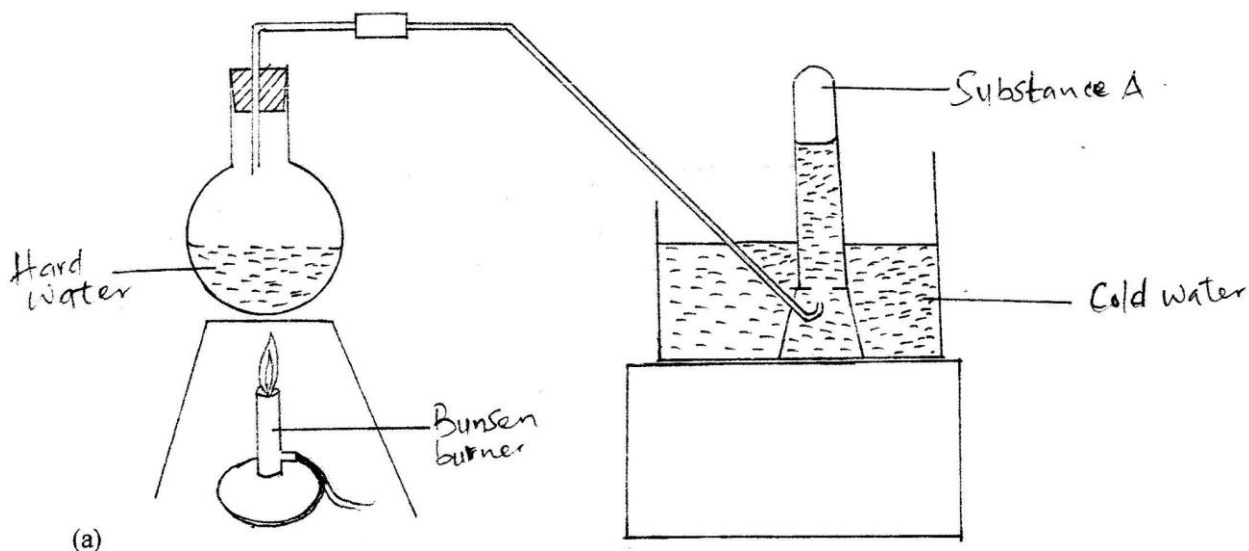

- a) Name substance A. (1 mark)
 - b) Explain why the heating of hard water produced substance A. (2marks)
4. Using dots (.) and crosses(x) to represent electrons, show bonding in the compounds formed when the following elements react: (si = 14, Na = 11 and Cl = 17) (1 mark)
 - a) Sodium and chlorine (1 mark)
 - b) Silicon and chlorine (1 mark)
 5. Zinc oxide reacts with acids and alkalis
 - a) Write the equation for the reaction between zinc oxide and:
 - i) Dilute sulphuric acid (1mark)
 - ii) Sodium hydroxide solution (1 mark)
 - b) What property of zinc oxide is shown by the reaction in (a) above? (1 mark)
 6. Use the information in the table below to answer the questions that follow. (The letters do not represent the actual symbols of the elements)

Element	B	C	D	E	F
Atomic number	18	5	3	5	20
Mass number	40	10	7	11	40

- a) Which two letters represent the same element? Give a reason. (2marks)
- b) Give the number of neutrons in an atom of element D (1 mark)
7. Give the name and draw the structural formula of the compound formed when one mole of ethane reacts with one mole of chlorine gas.
- 8 Determine the oxidation state of sulphur in the following compounds: (2 marks)
- a) H₂S.....
- b) Na₂S.....

9. A certain carbonate, GCO₃, reacts with dilute hydrochloric acid according to the equation given below:



If 1 g of the carbonate reacts completely with 20 cm³ of 1 M hydrochloric acid ,calculate the relative atomic mass of G

$$(C = 12.0 = 16.0)$$

10 The sketch with is converted it and question that

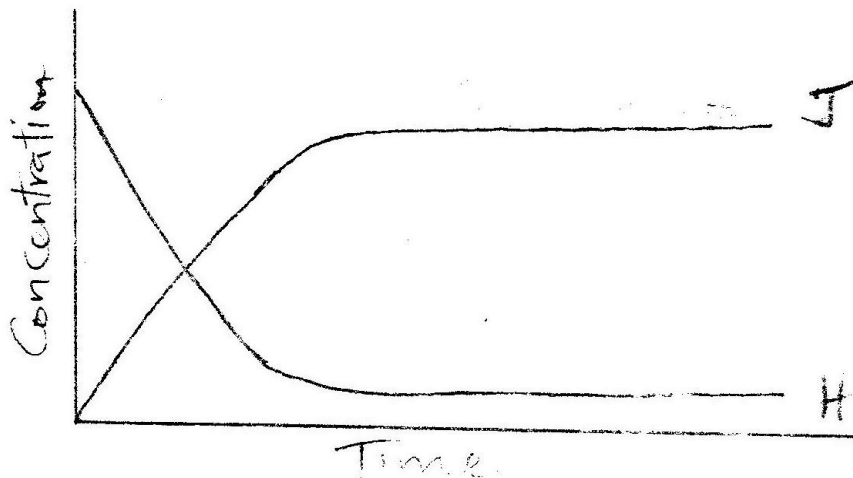

completely substance H into J. study answer the follows.

Why do the two curves become horizontal after sometime?

11. The reaction between how concentrated sodium hydroxide and chlorine produces sodium chlorate (V), sodium chloride and water
- (a) Write the equation for the reaction
- (b) Give one use of sodium chlorate (V)
12. In the industrial extraction of lead, the ore is first roasted in a furnace. The solid mixture obtained is then fed into another furnace together with coke, limestone and scarp iron. State the function of each of the following in this process: (3 mks)

- (a) Coke
- (b) Limestone
- (c) Scrap iron

13. Methane reacts with oxygen according to the equation given below.

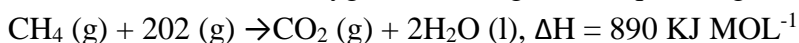

Calculate the volume of methane which would produce 111.25 kJ when completely burnt.

(Molar volume of a gas = 24 litres.)

(2 mks)

14. 100 g of a radioactive substance was reduced to 12.5 g in 15.6 years. Calculate the half-life of the substance. (2 mks)
15. In terms of structure and bonding, explain why graphite is used as a lubricant. (2mks)
16. The table below gives some information about elements I,II,III and IV which are in the same group of the periodic table. Use the information to answer the questions that follows.

Element	First Ionisation energy (kJmol ⁻¹)	Atomic Radius (nm)
I	520	0.15
II	500	0.19
III	420	0.23
IV	400	0.25

State and explain the relationship between the variations in the first ionization energies and the atomic radii. (3 mks)

17. (a) what condition is necessary for an equilibrium to be established? (1 mk)
- (b) When calcium carbonate is heated, the equilibrium shown below is established
- $$\text{CaCO}_3(\text{s}) \rightleftharpoons \text{CaO}(\text{s}) + \text{CO}_2(\text{g})$$

How would the position of equilibrium be affected if a small amount of dilute potassium hydroxide is added to the equilibrium mixture? Explain (2 mks)

18. In an experiment to investigate the conductivity of substances, a student used the set-up shown below.

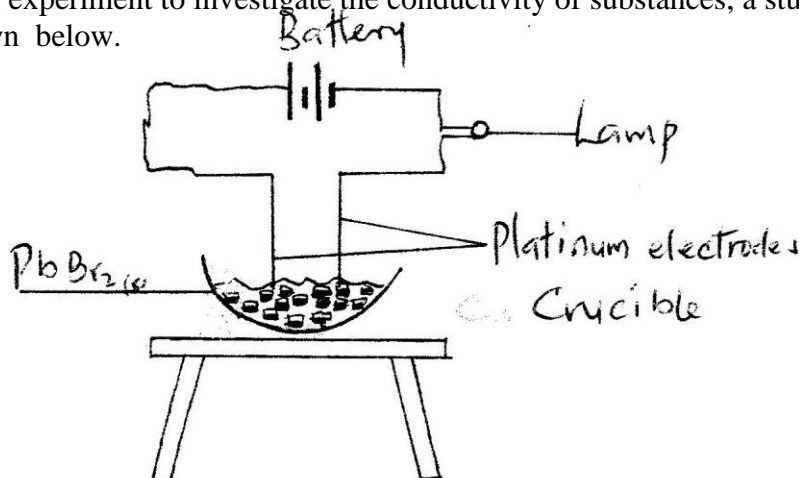

The Student noted that the bulb did not light

(1mk)

(a) What had been omitted in the set-up?

(b) Explain why the bulb lights when the omission is corrected (2 mks)

19. The scheme below shows the energy changes that are involved between ice, water and steam. Study it and answer the questions that follow

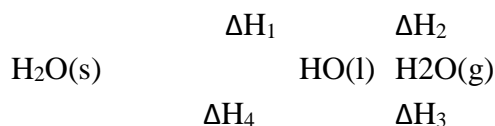

(b) What name is given to the energy change, ΔH_4 ? (1mk)

(c) What is the sign of ΔH_3 ? Give a reason (2 mks)

20. Equal volumes of 1M monobasic acids L and M were each reacted with excess magnesium turnings. The table below shows the volumes of the gas produced after one minute.

Acid	Volume of gas (cm ³)
L	40
M	100

Explain the differences in the volumes of the gas produced (2 mks)

21. The diagram below shows a set-up that was used to prepare and collect a sample of nitric acid

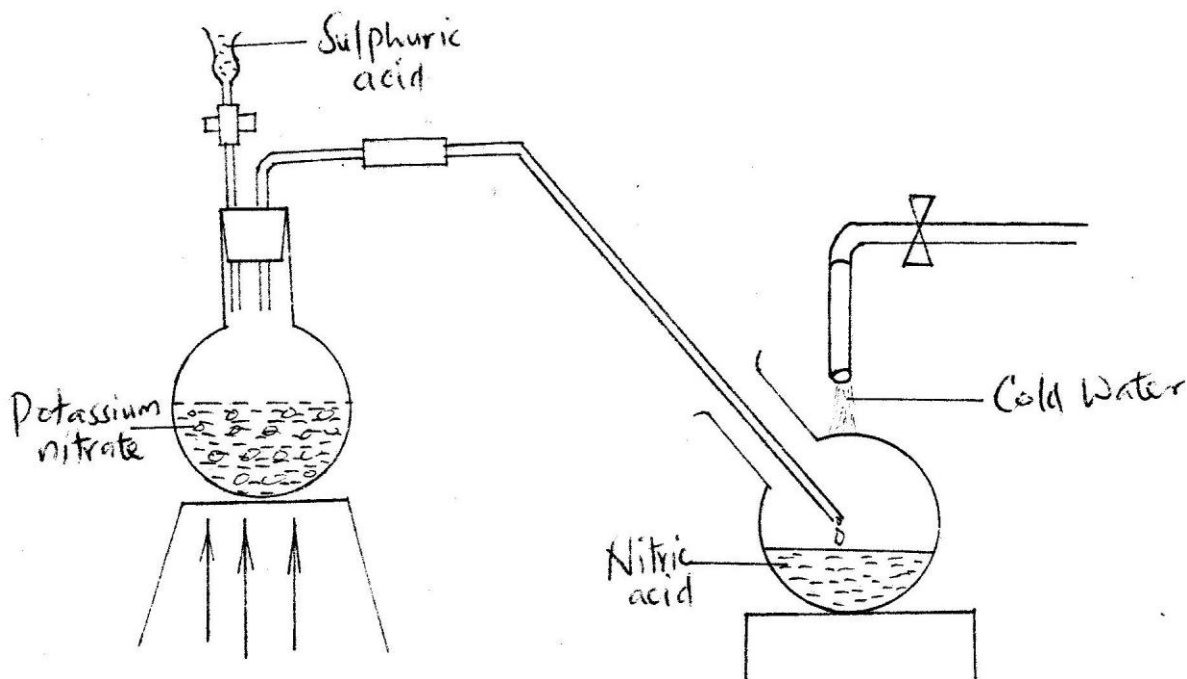

a. Give a reason why it is possible to separate nitric acid from sulphuric acid in the set-up (1 mk)

- b. Name another substance that can be used instead of potassium nitrate (1 mk)
- c. Give one use of nitric acid (1 mk)

22. Study the flow chart below and answer the questions that follow

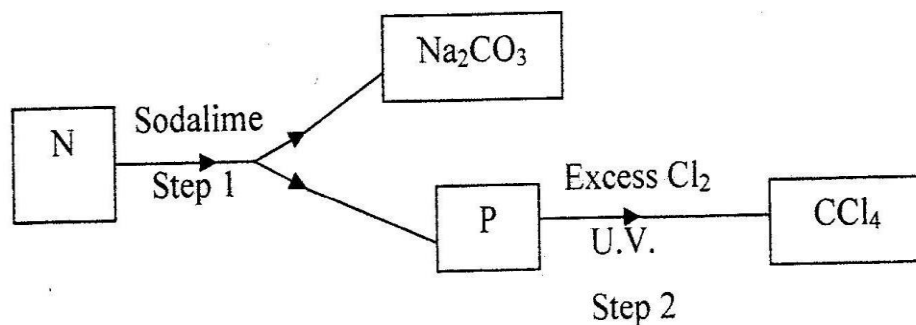

- (a) Identify N and P (2 mks)

N.....

P.....

- (b) What name is given to the type of halogenations/ chlorination reaction in step 2?

23. The set – up below was used to obtain a sample of iron

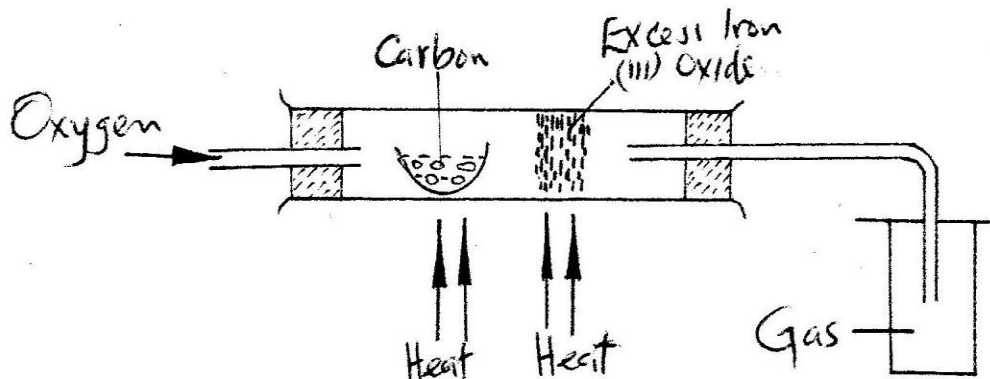

Write two equations for the reactions which occur in the combustion tube (2mks)

24. In an experiment, a gas jar containing most sulphur dioxide was inverted over another gas jar containing hydrogen sulphide gas
- State and explain the observation that was made (2mks)
 - State the precaution that should be taken when carrying out this experiment (1mk)

25. When a few drops of aqueous ammonia were added to copper (II) nitrate solution, a light blue precipitate was formed. On addition of more aqueous ammonia, a deep blue solution was formed.

Identify the substance responsible for the:

- Light blue precipitate (1mk)
- Deep blue solution (1mk)

26. When a current of 0.82A was passed for 5 hours through an aqueous solution of metal Z, 2.65 g of the metal were deposited. Determine the charge on the ions of metal Z. (1 Faraday = 96500 Coulombs:
Relative atomic mass of Z = 52
27. Dry carbon monoxide gas reacts with heated lead (II) oxide as shown in the equation below

$$\text{PbO(s)} + \text{CO(g)} \rightarrow \text{Pb(s)} + \text{CO}_2\text{(g)}$$
 (a) Name the process undergone by the lead (II) oxide (1 mk)
 (b) Give a reason for your answer in (a) above (1mk)
 (c) Name another gas that can be used to perform the same function as carbon monoxide gas in the above reaction.
28. When a hydrocarbon was completely burnt in oxygen, 4.2g of carbon dioxide and 1.71 g of water were formed. Determine the empirical formula of the hydrocarbon
 (H= 1.0 ; C=12.0; O = 16.0) (3 mks) **CHEMISTRY PAPER 233/2 K.C.S.E 2005**

QUESTIONS

1. (a) The diagram below shows spots of pure substance A,B, and C on a chromatography paper. Spot D is that of a mixture

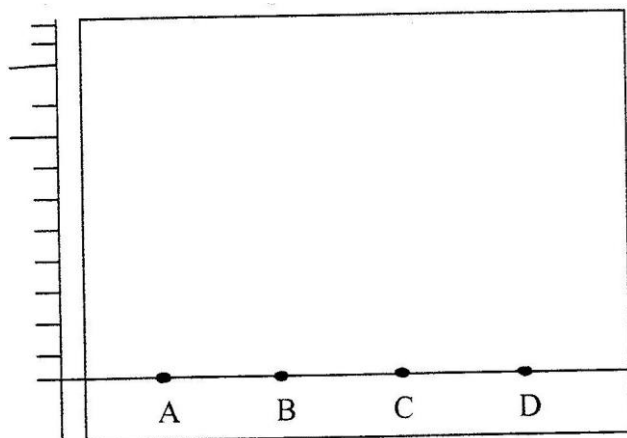

After development, A, B and C were found to have moved 8cm, 3cm and 6 cm respectively. D has separated into two spots which had moved 6cm and 8 cm

- (i) On the diagram
 I Label the baseline (origin) (1mk)
 II Show the positions of all the spots after development (3 mks)
 (ii) Identify the substances present in the mixture D (2mks)
 (b) Describe how solid ammonium chloride can be separated from a solid mixture of ammonium chloride and anhydrous calcium chloride (2mks)
 (c) The table shows liquids that are miscible and those that are immiscible

Liquid	L ₃	L ₄
L ₁	Miscible	Miscible
L ₂	Miscible	Immiscible

Use the information given to answer the questions that follow

- (i) Name the method that can be used to separate L1 and L3 from a mixture of two
(1 mk)
- (ii) Describe how a mixture of L₂ and L4 can be separated (2mks)

2. (a) Name one raw material which sodium hydroxide is manufactured (1 mk)
- (b) Sodium hydroxide pellets were accidentally mixed with sodium chloride 17.6 g of the mixture were dissolved in water to make one litre of solution. 100 cm³ of the mixture were dissolved in water to make one litre solution. 100cm³ of the solution was neutralized by 40cm³ of 0.M sulphuric acid (i) Write an equation for the reaction that took place (ii) Calculate the:
- (i) Number of moles of the substance that reacted with sulphuric acid (2mks) (ii) Number of moles of the substances that would react with sulphuric acid in the one litre of solution (1mk)
- (iii) Mass of the unreacted substances in one litre of solution (2 mks)
- (H = 1,0 ; Na = 23.0 ; Cl= 35.5 ; O= 16.0)

- (c) The diagram below shows an incomplete set-up used to prepare and collect ammonia gas

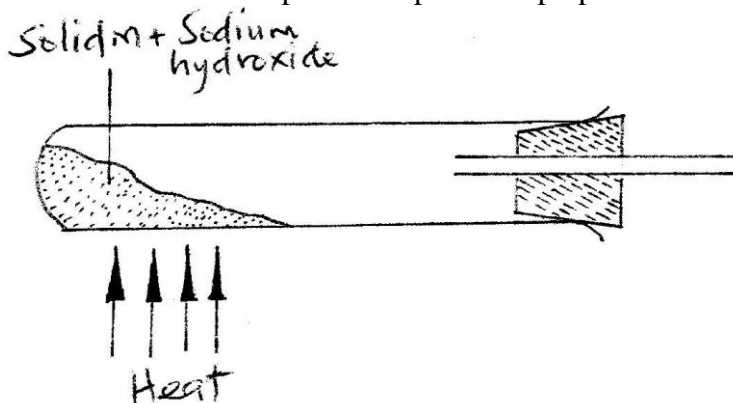

- (i) Name solid M (1 mk)
- (ii) Complete the diagram to show how a dry sample of ammonia gas can be collected (3 mks)
- (d) In an experiment, excess ammonia gas passed over heated copper (II) oxide on a combustion tube.
- (i) State the observation that was made in the combustion tube at the end of the experiment (1 mk)
- (ii) What property of ammonia is shown in the above reaction (1 mk)
- (iii) Name one use of ammonia (1 mk)
3. (a) The table below shows the standard reduction potentials for four half-cells. Study it and answer the questions that follow. (Letters are not the actual symbols of the elements)

	E^{\ominus} (volts)
$F_2(aq) + 2e \rightarrow 2F(aq)$; + 0.54
$G^{2+}(aq) + 2e \rightarrow G(s)$; -0.44
$H^{2+}(aq) + 2e \rightarrow H(s)$; + 0.34

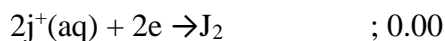

- (i) Identify the strongest reducing agent (1 mk)
- (ii) Write the equation for the reaction which takes place when solid G is added to a solution containing H^{2+} ions (1 mk)
- (iii) Calculate the E^{θ} value for the reaction in (ii) above (1mk)

- (b) The diagram below shows the apparatus that can be used to electrolyze acidified water to obtain hydrogen and oxygen gases. Study it and answer the questions that follow

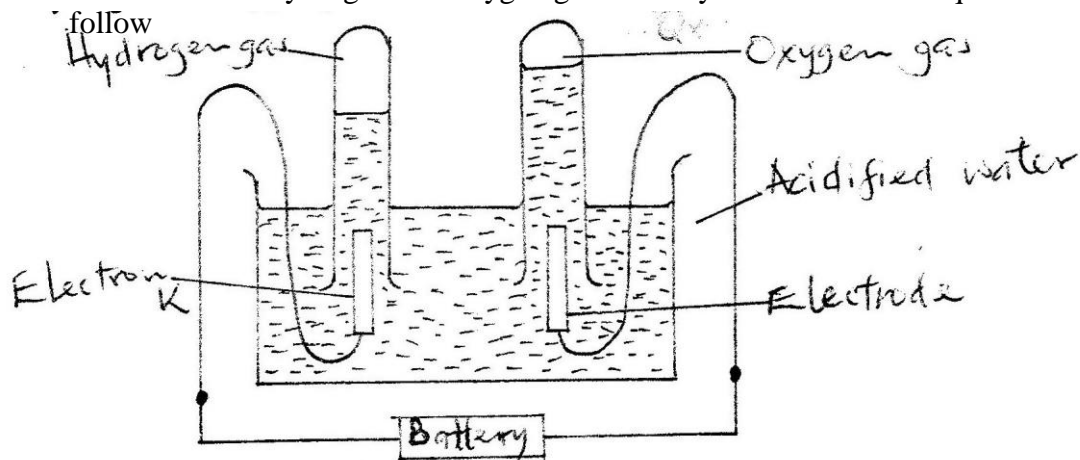

- (i) Identify the electrode at which oxidation takes place (1 mk)
- (ii) Give a reason why it is necessary to acidify the water (1mk)
- (iii) Explain why hydrochloric acid is not used to acidify the water (2mks)
- (c) During electrolysis of aqueous copper (II) sulphate, 144750 coulombs of electricity were used.

Calculate the mass of copper metal that was obtained

$$Cu = 64 \quad ; \quad 1 \text{ Faraday} = 96500 \text{ coulombs} \quad (3 \text{ mks})$$

4. (a) An atom Q can be represented as

52

Q

24

What does the number 52 represent? (1mk)

- (b) Study the information in the table below and answer the equations that follow
(Letters are not the actual symbols of the elements)

Element	Electronic Arrangement of stable i	Atomic oRadius (nm)	Ionic Radius (nm)
N	2.8.8	0.197	0.099
P	2.8.8	0.099	0.181
R	2.8	0.160	0.065
S	2.8	0.186	0.095

T	2	0.152	0.068
U	2.8	0.072	0.136

- (i) Write the formula of the compound formed when N reacts with P. (atomic numbers are N = 20; P = 17) (1 mk)
- (ii) Identify the elements which belong to the third period of the periodic table. Explain (2 mks)
- (iii) Which of the element identified in b (ii) above comes first in the third period? Explain (2 mks)
- (iv) Select two elements which are non- metals (1 mk)
- (c) The table below gives some properties of substances I, II, III, and IV. Study it and answer the questions that follow

Substance	Electrical conductivity		M.P (⁰ C)	B.P (⁰ C)
	Solid	Molten		
I	Does not conduct	Conducts	801	1420
II	Conducts	Conducts	650	1107
III	Does not conduct	Does not conduct	1700	2200
IV	Does not conduct	Does not conduct	113	440

- (i) What type of bonding exists in substances I and II (2mks)
- I
- II
- (ii) Which substances is likely to be sulphur? Explain (2mks)
5. In an experiment, a piece of magnesium ribbon was cleaned with steel wool. 2.4 g of the clean magnesium ribbon was placed in a crucible and completely burnt in oxygen. After cooling, the product weighed 4.0 g
- (a) Explain why it was necessary to clean the magnesium ribbon (1mk)
- (b) What observation was made in the crucible after burning (1 mk)
- (c) Why was there an increase in mass? (1 mk)
- (d) Write the equation for the reaction which took place in the crucible (1mk)
- (e) The product in the crucible was shaken with water and filtered. Explain the observation which was made when blue and red litmus papers were dropped into the filtrate. (3 mks)
6. (a) The list below shows the formulae of some organic compounds. Use it to answer the questions that follow.
- V₁ HC₃CH₂CH₂OH
- V₂ CH₃CH₂CH₃

O

||

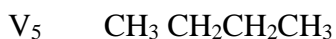

- (i) Select two compounds which
- I are not hydrocarbons (1mk)
- II Belong to the same homologous series (1 mk)
- (ii) Identify the compound that is likely to undergo polymerization. Give a reason for your answer. (2 mks)

a. The structures below represents two cleansing agents:



In the table below, give one advantage and one disadvantage of using each one of them

	Advantage	Disadvantage
R – COO ⁻ Na ⁺		
R - OSO ₃ – Na ⁺		

- b. Under certain, ethanoic acid (C₂H₄O₂) and ethanol (C₂H₅OH) react to form a sweet smelling compound.
- (i) What is the general name of compound to which the sweet smelling compound belong? (1mk)
- (ii) Write the formula of the sweet smelling compound (1 mk)
- (iii) Give one use of ethanoic acid other the formation of the sweet smelling compounds (1 mk)
- (iv) Write the equation for the reaction dilute ethanoic acid and solid potassium carbonate (1mk)

c. Fibres are either synthetic or natural. Give one:

(i) Example of a natural fibre (1mk)

(ii) Advantage of synthetic fibres have over natural fibres (1mk)

7. (a) Below is a simplified diagram of the Downs Cell used for the manufacture of sodium. Study it and answer the questions that follow

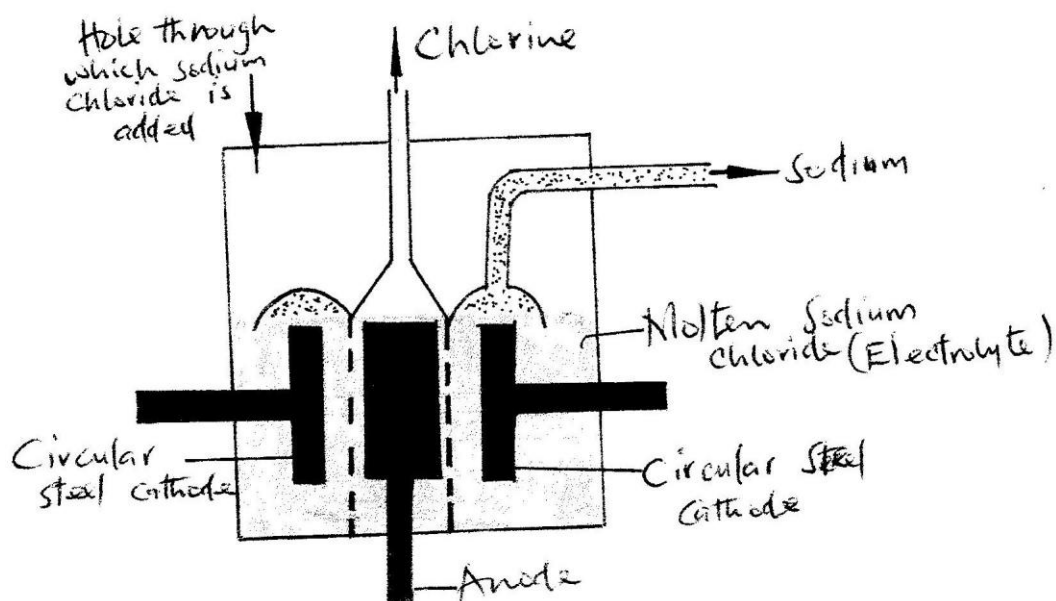

- (i) What material is the anode made of? Give a reason (2 mks)
- (ii) What precaution is taken to prevent chlorine and sodium from re-combination? (1 mk)
- (iii) Write an ionic equation for the reaction in which chlorine gas is formed (1mk) (b) In the Downs process, (used for manufacture of sodium), a certain salt is added to lower the melting point of sodium chloride from about 800°C to about 600°C .
- (i) Name the salt that is added (1mk)
- (ii) State why it is necessary to lower the temperature (1mk)
- (c) Explain why aqueous sodium chloride is not suitable as an electrolyte for the manufacture of sodium in the Downs process (2mk)
- (d) Sodium metal reacts with air to form two oxide. Give the formulae of two oxides (1mk)

CHEMISTRY PAPER 1 2006

QUESTIONS

1. (a) What is meant by isomerism? (1mark)
- (b) Draw and name two isomers of butane. (2 marks)
2. The diagram below represent a set-up that was used to show that part of air is used during burning.

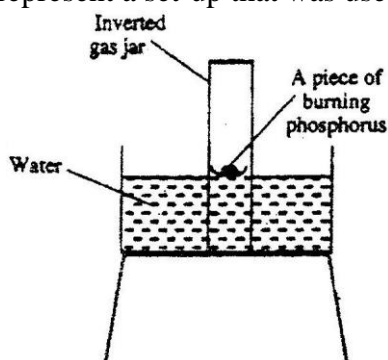

- a) Given that phosphorus used was in excess, draw a diagram of the set-up at the end of the experiment (when there was no further observable change). (1mk)
- b) Suggest one modification that should be made on the apparatus if the percentage of the air used is to be determined. (1mk)

3. 60cm³ of oxygen gas diffused through a porous partition in 50 seconds. How long would it take 60cm³ of sulphur (IV) oxide gas to diffuse through the same partition under the same conditions? (S= 32.0, O = 16.0) (3marks)

4. a) Complete the nuclear equation below.

(1mark)

b) ${}_{18}^{37}\text{A} \rightarrow {}_{17}^{37}\text{B} + \dots$

A.....B

18 17

(b) State one:

(i) Use of radioisotopes in agriculture (1mark)

(ii) Danger associated with exposure of human beings to radioisotopes

(1 mark)

5. The atomic numbers of elements C and D are 19 and 9 respectively. State and explain the electrical conductivity of the compound CD in:

a) Solid state (1 ½ marks)

b) aqueous state. (1 ½ marks)

6. In an experiment to study the properties of concentrated sulphuric acid, a mixture of the acid and wood charcoal was heated in a boiling tube.

a) write the equation of the reaction that took place in the boiling tube.(1mark)

b) Using oxidation numbers, show that reduction and oxidation reactions took place in the boiling tube (2 mark)

7. A group of compounds called chlorofluorocarbons have a wide range of uses but they also have harmful effects on the environment.

State one:

a) Use of chlorofluorocarbons (1 mark)

b) Harmful effect of chlorofluorocarbons on the environments. (1 mark)

8. when 94.5g of hydrated barium hydroxide, ba(OH)₂. nH₂O were heated to constant mass, 51.3g of anhydrous barium hydroxide were obtained. Determine the empirical formula of the hydrated barium hydroxide. (3 marks)

9. at 200C, NO₂ and N₂O₄ gases exist in equilibrium as shown in the equation below

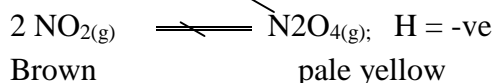

State and explain the observation that would be made when;

a) A syringe containing the mixture at 200C is immersed in ice-cold water

(1 ½ mks)

b) the volume of the gaseous mixture in a syringe is reduced. (1 ½ mks) 10 Name the process which takes place when:

- a) Solid carbon (IV) oxide (dry ice) changes directly into gas (1 mark)
- b) A red litmus paper turns white when dropped into chlorine water. (1 mark)
- c) Propane gas molecules are converted into a giant molecule (1 mark)
11. a) water from a town in Kenya is suspected to contain chloride ions but not sulphate ions. Describe how the presence of the chloride ions in the water can be shown. (1 mk)
- b) State one advantage of drinking hard water rather than soft water. (1 mk)
12. The table below shows the relative atomic masses and the percentage abundance of the isotopes L1 of element L.
13. The diagram below represents the set-up that was used to prepare and collect hydrogen chloride gas in the laboratory.

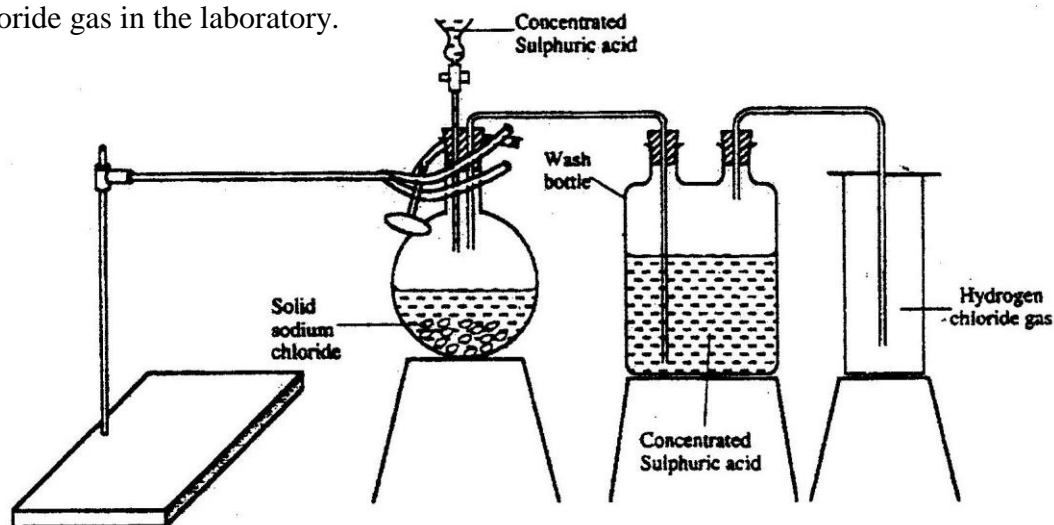

- a) State the purpose of concentrated sulphuric acid in the wash bottle. (1 mark)
- b) Write an equation for the reaction between dry hydrogen chloride gas and heated iron (1 mark)
- c) Hydrogen chloride gas is dissolved in water to make hydrochloric acid. State one use of hydrochloric acid.
14. Below is a list of oxides. MgO , N_2O , K_2O , CaO , and Al_2O_3 .
Select:
- a) A neutral oxide (1 mk)
- b) A highly water soluble basic oxide (1 mark)
- c) An oxide which can react with both sodium hydroxide solution and dilute hydrochloric acid. (1 mk)
15. Study the standard reduction potential given and answer the questions that follow.

(The letters are not the actual symbols of the elements).

	E^\ominus (volts)
$M_{2+(aq)} + 2e \rightarrow M_{(s)}$	-0.76
$N_{2+(aq)} + 2e \rightarrow N_{(s)}$	-2.37
$P_{+(aq)} + e \rightarrow P_{(s)}$	+0.80
$Q^{2+(aq)} + 2e \rightarrow Q_{(s)}$	-0.14

- a) The standard reduction potential for $\text{Fe}^{2+}(\text{aq})$ is -0.44 volts. Select the element which would best protect iron from rusting. (1 mark)
- b) Calculate the E^\ominus value for the cell represented as $\text{M}_{(\text{s})} / \text{M}^{2+}_{(\text{aq})} // \text{P}^{+}_{(\text{aq})} / \text{P}_{(\text{s})}$. (2mks)
- 16 When hydrogen sulphide gas was bubbled into an aqueous solution of iron (III) chloride, a yellow precipitate was deposited. (1mark)
- a) The standard reduction potential for $\text{Fe}^{2+}(\text{aq})$ is -0.44 volts. Select the element which would best protect iron from rusting. (1 mark) b) Write an equation for the reaction that took place. (1 mark)
- c) What type of reaction was undergone by hydrogen by hydrogen sulphide in this reaction? (1mark)
17. The first step in the industrial manufacture of nitric acid is the catalytic oxidation of ammonia gas.
- (a) What is the name of the catalyst used? (1 mk)
- (b) Write the equation for the catalytic oxidation of ammonia gas. (1mk)
- (c) Nitric acid is used to make ammonium nitrate, state two uses of ammonium nitrate. (1 mark)
18. Study the diagram below and answer the question that follows.

Describe one chemical test that can be carried out to identify substance s. (2 marks)

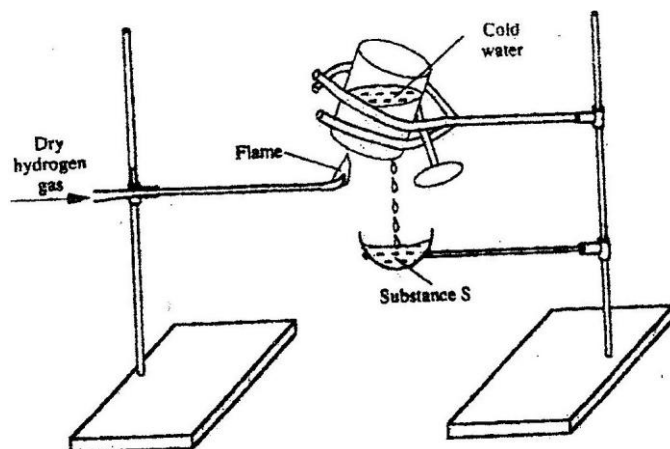

19. a) starting from solid magnesium hydroxide. (1mark)

- b) Give one use of magnesium hydroxide. (1 mark)
20. a) Distinguish between a covalent bond and a co-ordinate bond (2 marks)
- b) Draw a diagram to show bonding in an ammonium ion. (1 mark)
21. (a) Explain why the metals magnesium and aluminium are good conductors of electricity. (1 mark)
- b) Other than cost, give two reasons why aluminium is used for making electric cables while magnesium is not (2mks)
22. The diagram below represents part of a set – up used to prepare and collect gas T.

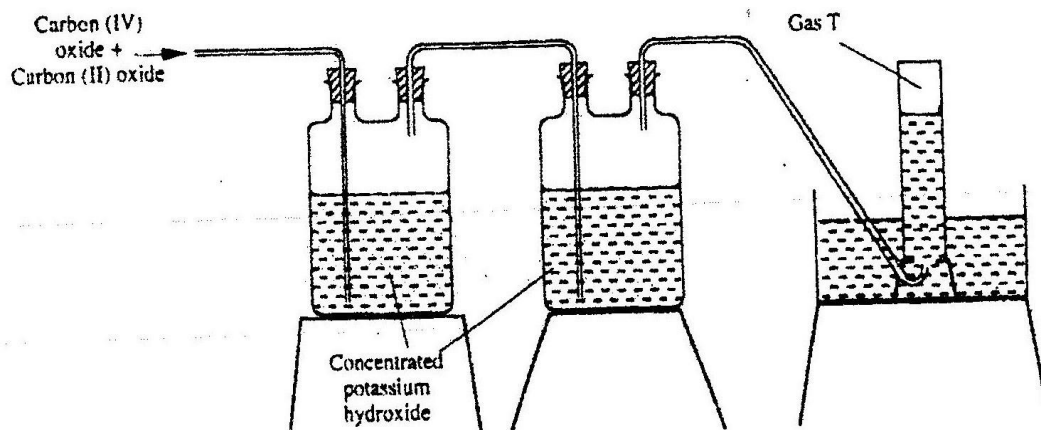

- a) Name two reagents that are reacted to produce both carbon (IV) oxide and carbon(II) oxide.(1mk)
- b) Write the equation for the reaction which takes place in the wash bottles.(1mk)
- c) Give a reason why carbon(II) oxide is not easily detected.(1mk)
23. Explain why the boiling point of ethanol is higher than that of hexane.
(Relative molecular mass of ethanol is 46 while that of hexane is 86)
24. a) Complete the table below to show the colour of the given indicator in

Indicator	Colour in	
	Acid solution	Basic solution
Methyl orange	Yellow
Phenolphthalein	Colourless

- b) How does the P^H value of 0.1 M potassium hydroxide solution compare with that of 0.1M aqueous ammonia? Explain. (2mks)
25. Study the properties of substances V1 to V4 in the table below and answer the questions that follow.

Substance	Solubility in water	Solubility	Melting Point($^{\circ}C$)	Boiling point($^{\circ}C$)
V1	Insoluble	Soluble	-30	250
V2	Insoluble	Insoluble	1535	3000
V3	Insoluble	Soluble	16.8	44.8
V4	Insoluble	Soluble	75	320

- a) Which of the substances are liquids at $240^{\circ}C$?

- b) Describe how a mixture containing V2 and V4 can be separated (2mks)
 26. The graph below shows a curve obtained when water at 20°C was heated for 15 minutes.

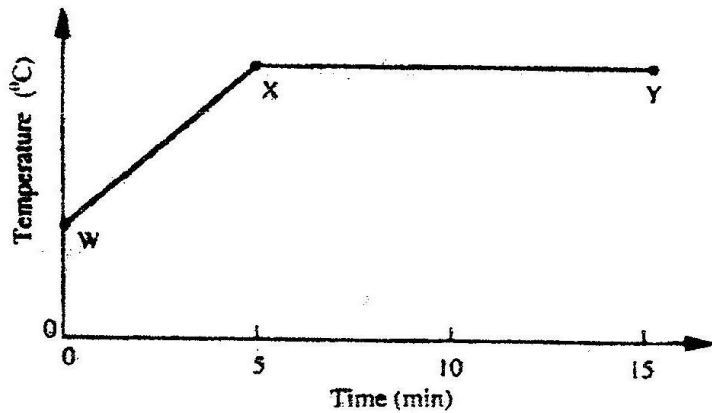

- a) What happens to the water molecules between points W and X? (1mk)
 b) In which part of the curve does a change of state occur? (1mk)
 c) Explain why the temperature does not rise between points X and Y. (1mk)
 27. Study the flow chart below and answer the questions that follow.

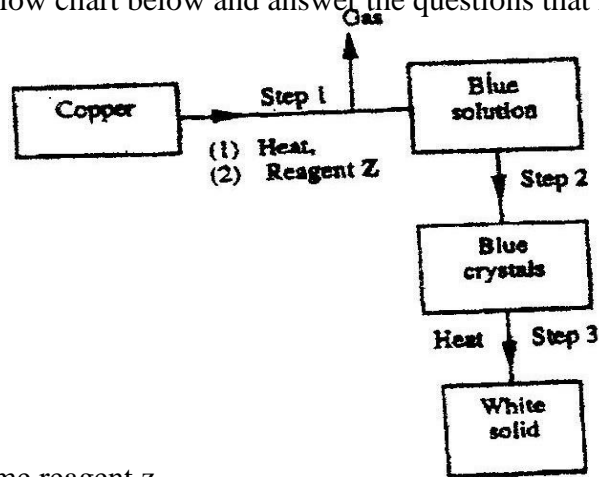

- a) Name reagent z.
 b) Describe the process which takes place in step 2. (1mk)
 c) Identify the white solid. (1mk)
 28. Study the diagram below and answer the questions that follow.

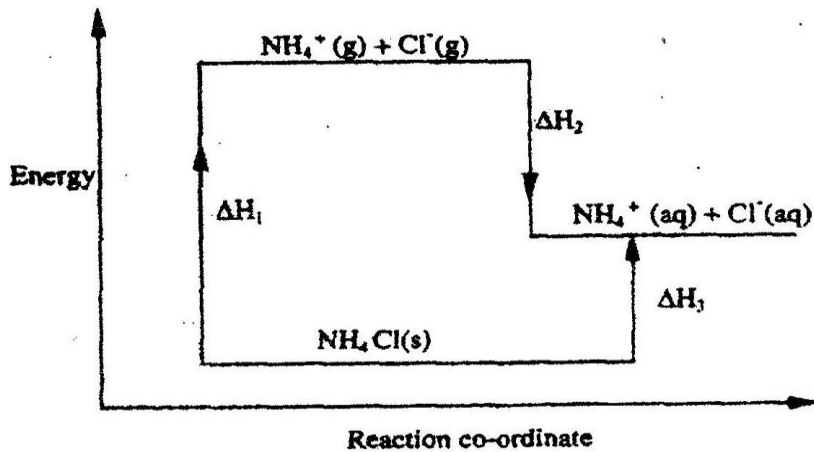

- a) What do ΔH_1 and ΔH_2 represent? (2mks)

- b) Write an expression to show the relationship between H_1 , H_2 and H_3 . (1mk) **CHEMISTRY PAPER 2 (233/2) 2006**

QUESTIONS

1. a) What is an electrolyte? (1mk)
 b) State how the following substances conduct electricity.
 i) Molten calcium chloride (1mk)
 ii) Graphite. (1mks)
 c) The diagram below shows a set up that was used to electrolyse aqueous magnesium sulphate.

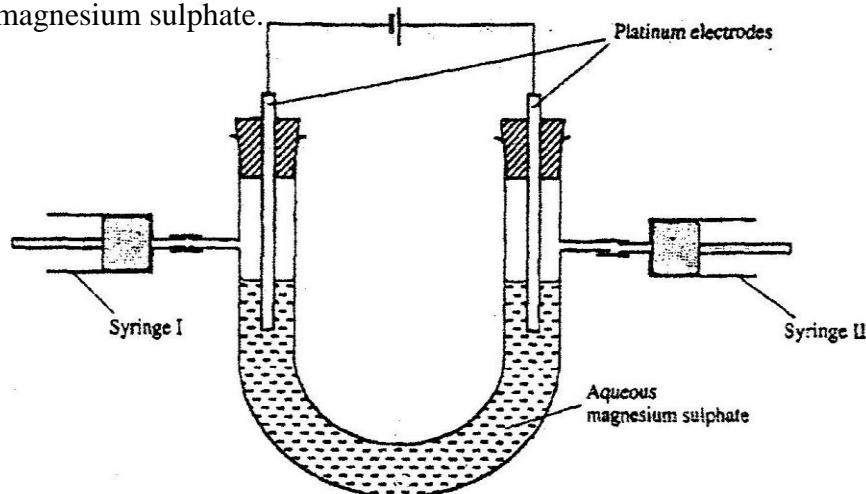

- i) On the diagram above, using an arrow, show the direction of flow of electrons. (1mk)
 ii) Identify the syringe in which hydrogen gas would be collected. Explain (1mk)
 d) Explain why the concentration of magnesium sulphate was found to have increased at the end of the experiment. (2mks)
 e) During the electrolysis, a current of 0.72A was passed through the electrolyte for 15 minutes. Calculate the volume of gas produced at the anode. (1 Faraday = 96 500 coulombs; molar gas volume is 24000cm^3 at room temperature). (4mks)
2. a) In an experiment to determine the molar heat of reaction when magnesium displaces copper, 0.15g of magnesium powder were added to 25.0cm^3 of 2.0M copper (II) chloride solution. The temperature of copper (II) chloride solution was 25°C . While that of the mixture was 43°C .
- i) Other than increase in temperature, state and explain the observations which were made during the reaction. (3mks)
 ii) Calculate the heat change during the reaction (specific heat capacity of the solution = $4.2\text{Jg}^{-1}\text{K}^{-1}$ and the density of the solution = 1g/cm^3) (2mks)
 iii) Determine the molar heat of displacement of copper by magnesium. (Mg=24.0).
 iv) Write the ionic equation for the reaction. (1mk)
 v) Sketch an energy level diagram for the reaction. (2mks)

b) Use the reduction potentials given below to explain why a solution containing copper ions should not be stored in a container made of zinc.

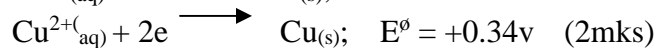

3. a) Distinguish between isotopes and allotropes. (2mks)

b) The chart below is part of the periodic table. Study it and answer the questions that follow. (The letters are not the actual symbols of the elements).

	A					B	
	C	D					E

i) Select the element in period three which has the shortest atomic radius. Give a reason for your answer. (2mks)

ii) Element F has the electronic structure, 2.8.18.4 on the chart above, indicate the position of element F. (1mks)

iii) State one use of the elements of which E is a member. (1mk) iv) Write an equation to show the action of heat on the nitrate of element C. (1mks)

c) When 3 litres of chlorine gas were completely reacted with element D, 11.875g of the product were formed. Determine the relative atomic mass of element D.

(Atomic mass of chlorine = 35.5; molar gas volume = 24 litres). (3mks)

a) The diagram below shows some processes that take place during the industrial manufacture of sulphuric acid.

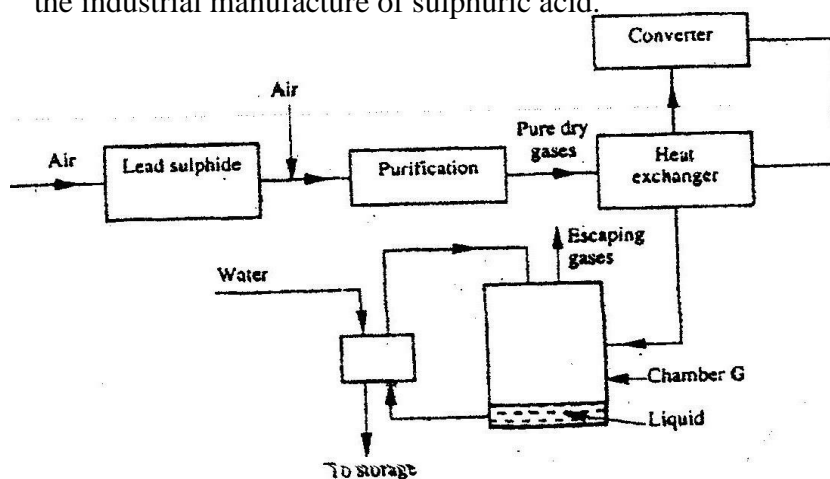

(i) Write the equation for the reaction in which sulphur dioxide gas is produced. (1mk)

(ii) Why is it necessary to keep the gases pure and dry? (1mk)

(iii) Describe the process that takes place in chamber G. (1mk)

(iv) Name the gases that escape into the environment. (1mk)

- (v) State and explain the harmful effect on the environment of one of the gases named in (iv) above (1mk)
- (vi) Give one reason why it is necessary to use a pressure of 2-3 atmospheres and not more. (1mk)

- b) (i) Complete the table below to show the observations made when concentrated sulphuric acid is added to the substances shown. (2mks)

Substance	Observation
Iron fillings	
Crystals of white sugar	

- (ii) Give reasons for the observations made using:

I iron fillings (1mk)

II Crystals of white sugar. (1mk)

- (c) Name one fertilizer made from sulphuric acid. (1mk)

- (d) Suggest a reason why BaSO_4 (pigment made from sulphuric acid) would be suitable in making paint for cars. (1mk)

5. a) What name is given to a compound that contains carbon and hydrogen only? ($\frac{1}{2}$)

- b) Hexane is a compound containing carbon and hydrogen.

(i) What method is used to obtain hexane from crude oil? (1mk)

(ii) State one use of hexane (1mk)

- c) Study the flow chart below and answer the questions that follow.

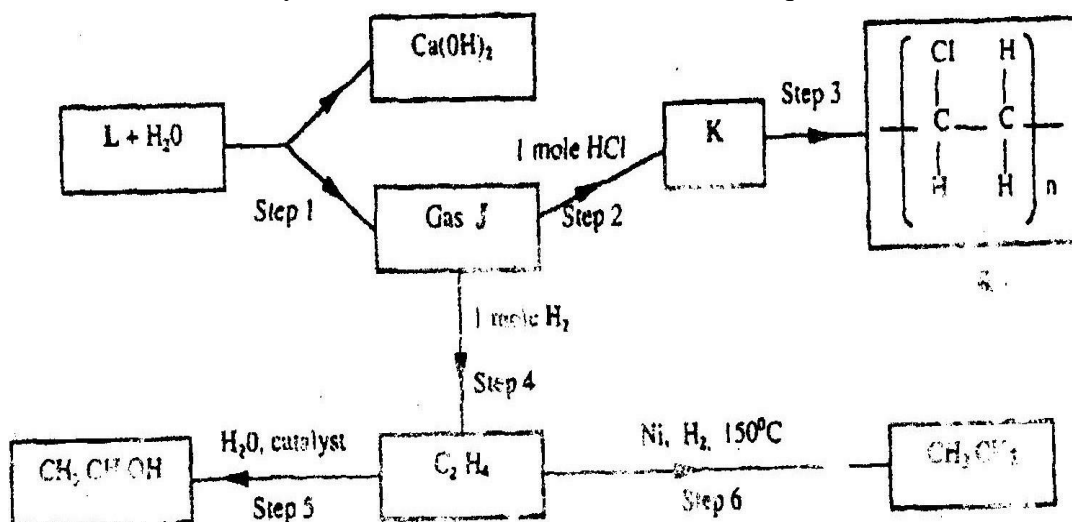

(i) Identify reagent L. (1mk)

(ii) Name the catalyst used in step 5. (1mk)

(iii) Draw the structural formula of gas J. (1mk)

(iv) What name is given to the process that takes place in step 5? ($\frac{1}{2}$ mk)

- d) (i) write the equation for the reaction between aqueous sodium hydroxide and

aqueous ethanoic acid. (1mk)

- (ii) Explain why the reaction between 1g of sodium carbonate and 2M hydrochloric acid is faster than the reaction between 1g of sodium carbonate and 2M ethanoic acid. (1mks)

6. The extraction of iron from its ores takes place in the blast furnace. Study it and answer the questions that follow.

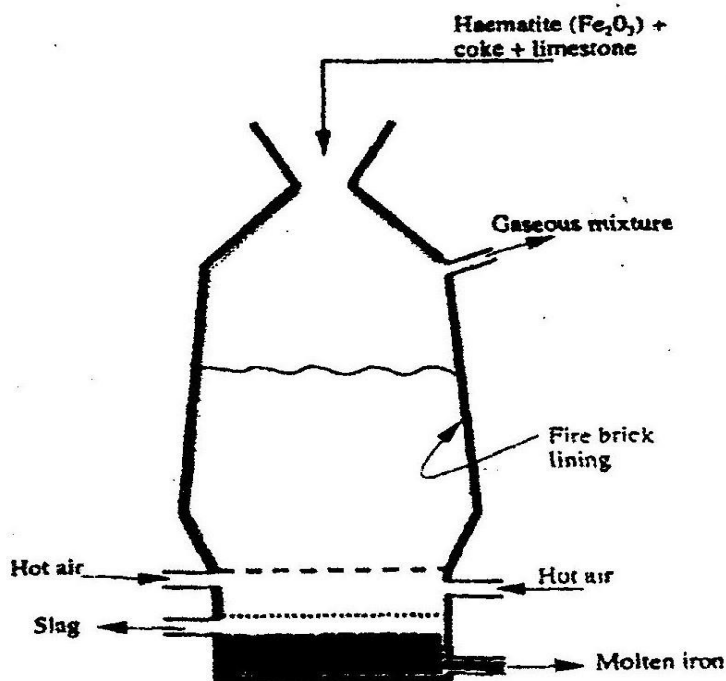

- a) Name
- (i) One of the substances in the slag (1mk)
 - (ii) Another iron ore material used in the blast furnace. (1mk)
 - (iii) One gas which is recycled. (1mk)
- b) Describe the process which lead to the formation of iron in the blast furnace
- c) State the purpose of limestone in the blast furnace. (3mks)
- d) Give a reason why the melting point of the iron obtained from the blast furnace is 12000 C while tat of pure iron is 15350C (1mk)
- e) State two uses of steel (2mks)

7. The table below shows the volumes of nitrogen dioxide gas produced when different volume of 1M nitric acid were each reacted with 2.07 g of lead at room temperature.

Volume of 1 M nitric acid (cm ³)	Volume of nitrogen dioxide gas (cm ³)
5	60
15	180
25	300
35	420

45	480
55	480

- a) Give a reason why nitric acid is not used to prepare hydrogen gas. (1mk)
- b) Explain how the rate of the reaction between lead and nitric acid would be affected if the temperature of the reaction mixture was raised. (2mks)
- c) On the grid provided below, plot a graph of the volume of the gas produced (Vertical axis) against volume of acid. (3 marks)
- d) Using the graph, determine the volume of:
- Nitrogen dioxide produced when 30cm³ of 1 M nitric acid were reacted with 2.07 g of lead (1mrk)
 - 1M nitric acid which would react completely with 2.07g of lead. (1mk) e)
Using the answer in d(i) above, determine:
- The volume of 1M nitric acid that would react completely with one mole of lead (pb=207) (2mks)
 - The volume of nitrogen dioxide gas produced when one mole of lead reacts with excess 1 M nitric room temperature. (1mk)
- f) Calculate the number of moles of:
- 1M nitric acid that reacted with one mole of lead (1mk)
 - nitrogen dioxide produced when one mole of lead were reacted with excess nitric acid. (Molar gas volume of 2400cm³) (1mk)
- g) Using the answers obtained in f (i) and (ii) above, write the equation for the reaction between lead and nitric acid given that one mole of lead nitrate and two moles of water were also produced. (1mk)

CHEMISTRY
PAPER 1
THEORY
OCT./NOV. 2007

2 hours

1. The diagram below shows a “Jiko” when in use. Study it and answer the questions that follow.

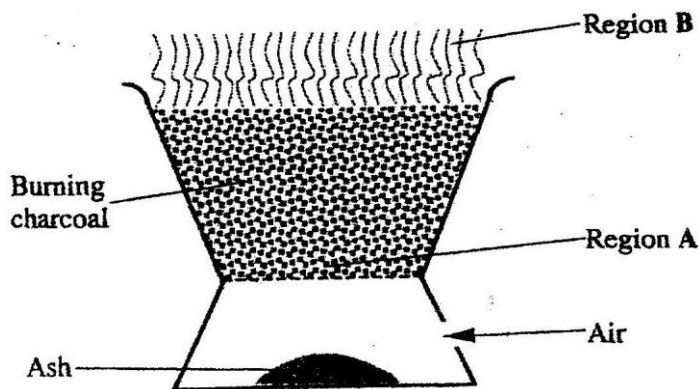

- a) Identify the gas formed at region A. (1mk)
-
- b) State and explain the observation made at region B. (2mks)
-
-
2. 15.0cm^3 of ethanoic acid (CH_3COOH) was dissolved in water to make 500cm^3 of solution. Calculate the concentration of the solution in moles per litre. (C=12.0;H=1.0;O=16.0; density of ethanoic acid is 1.05 g/cm^3) (3mks)
-
-
-
3. Both chlorine and iodine are halogens.
- a) What are halogens? (1mk)
-
- b) In terms of structure and bonding, explain why the boiling point of chlorine is lower than that of iodine. (2mks)
-
-
4. The diagram below shows a Bunsen burner when in use.

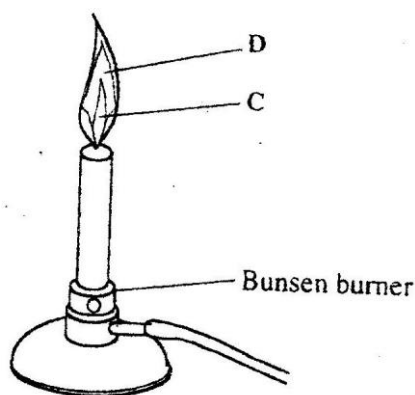

Name the regions labeled C and D. (2mks)

C

D

5. When a student was stung by a nettle plant, a teacher applied an aqueous solution of ammonia to the affected area of the skin and the student was relieved of pain. Explain. (2mks)

.....

6. In an experiment, a few drops of concentrated nitric acid were added to aqueous iron(II) sulphate in a test – tube. Excess sodium hydroxide solution was then added to the mixture.

a) State the observations that were made when:

i) Concentrated nitric acid was added to aqueous iron (II) sulphate(1mk)

.....

ii) Excess sodium hydroxide was added to the mixture. (1mk)

.....

b) Write an ionic equation for the reaction which occurred in (a) (ii) above.(1mk)

.....

7. a) Use the information given below to draw a labeled diagram of an electrochemical cell that can be constructed to measure the electromotive force between G and J.

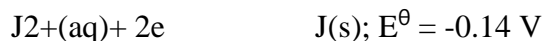
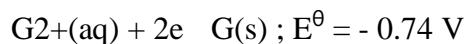

b) Calculate the E^{θ} value for the cell constructed in (a) above. (1mk)

.....

.....

8. Explain why there is a general increase in the first ionization energies of the

- elements in period 3 of the periodic table from left to right. (2mks)
9. Study the flow chart below and answer the question that follows.

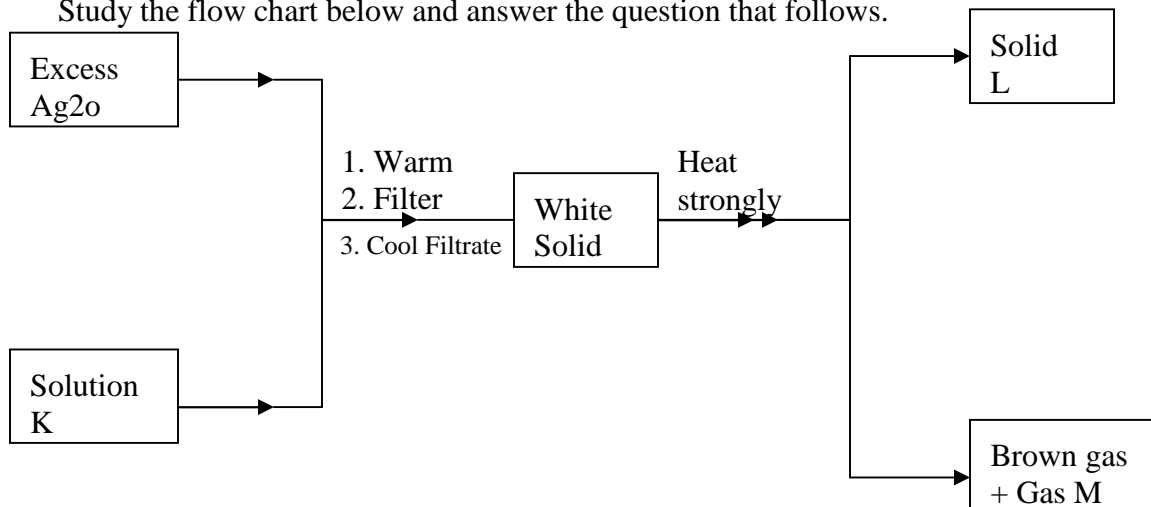

Identify:

- a) Solution K
b) Solid L
c) Gas M
9. The thermo chemical equations for the formation of hydrogen peroxide under standard conditions are:

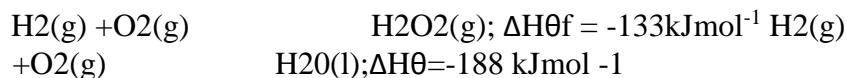

Write the thermo chemical equation for the molar heat of vaporization of hydrogen peroxide. (2mks)

The set-up below was used to collect a dry sample of a gas.

10.

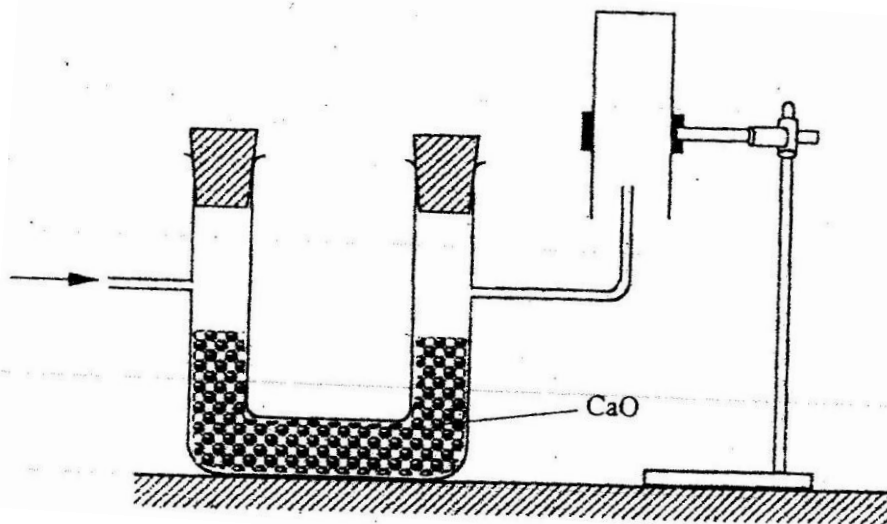

Give two reasons why the set-up cannot be used to collect carbon (IV) oxide gas. (2mks)

12. a) State the Charles law (1mk)

- b) The volume of a sample of nitrogen gas at a temperature of 291 K and 1.0×10^5 Pascal's was $3.5 \times 10^{-2} \text{m}^3$. Calculate the temperature at which the volume of the gas would be $2.8 \times 10^{-2} \text{m}^3$ at 1.0×10^5 Pascal. (2mks)
13. a) name the process that takes place when:
- Crystals of zinc nitrate change into solution when exposed to air (1mk)
 - An alcohol reacts with an organic acid in the presence of a catalyst to form a sweet smelling compound. (1mk)

- b) Propane can be changed into methane and ethane as shown in the equation below;

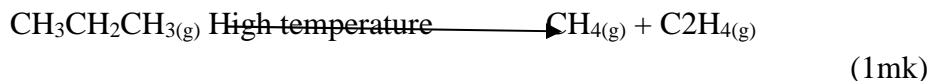

Name the process undergone by propane. (1mk)

14. a) Distinguish between nuclear fission and nuclear fusion. (2mks)

b) Describe how solid wastes containing radioactive substances should be disposed of.

(1mk)

15. a) Explain why permanent hardness in water cannot be removed by boiling. (2mks)
- b) Name two methods that can be used to remove permanent hardness from water.

(1mk)

- 16 The table below shows the tests that were carried out on solid N and the observations made.

I	Test	Observations
II	Dilute hydrochloric acid was added solid N.	A colourless solution was formed
III	To the colourless solution obtained test II, excess sodium hydroxide so was added.	A white precipitate was formed which dissolved to form a colourless solution.

Write the formula of the anion in;

- a) Solid N (1mk)
- b) The colourless solution formed in test III (1mk)
17. The relative formula mass of a hydrocarbon is 58. Draw and name two possible structures of the hydrocarbon (C=12.0; H=1.0) (3mks)
18. starting with sodium metal, describe how a sample of crystals of sodium hydrogen carbonate may be prepared. (3mks)

19 The flow chart below shows steps used in the extraction of zinc from one of its ores.

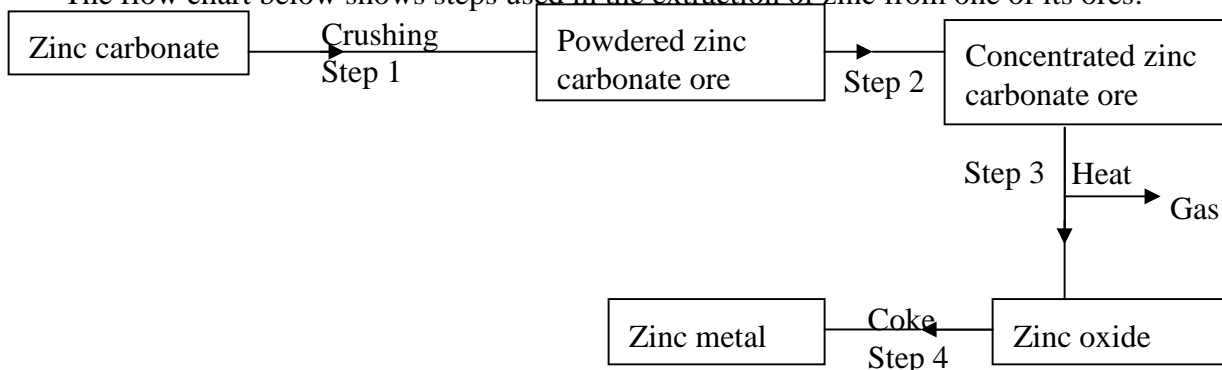

- a) Name the process that is used in step 2 to concentrate the ore. (1mk)
- b) Write an equation for the reaction which takes place in step 3. (1 mark)
- c) Name one use of zinc other than galvanizing. (1mk)
20. An alcohol has the following composition by mass: hydrogen 13.5%, oxygen 21.6% and carbon 64.9%
- a) Determine the empirical formula of the alcohol (C=12.0; H=1.0; O=16.0). (2mks)
21. a) When brine is electrolyzed using inert electrodes, chlorine gas is liberated at the anode instead of oxygen. Explain this observation. (2mks)
- b) Name the product formed at the cathode. (1 mk)
22. 6.84g of aluminium sulphate were dissolve in 150cm³ of water. Calculate the molar concentration of the sulphate ions in the solution. (Relative formula mass of aluminium sulphate is 342)
-
-
-
23. The table below shows the relative molecular masses and the boiling points of pentane and propan-1-01

	Relative molecular mass	Boiling point(°C)
Pentane	72	36
Propan-1-01	60	97

Explain why the boiling point of propane 1-1-01 is higher than that of pentane. (2mks) 24. State and explain the observations made when excess ammonia gas reacts with chlorine gas (3mks)

25. The diagram below shows a student's set-up for the preparation and collection of hydrogen gas.

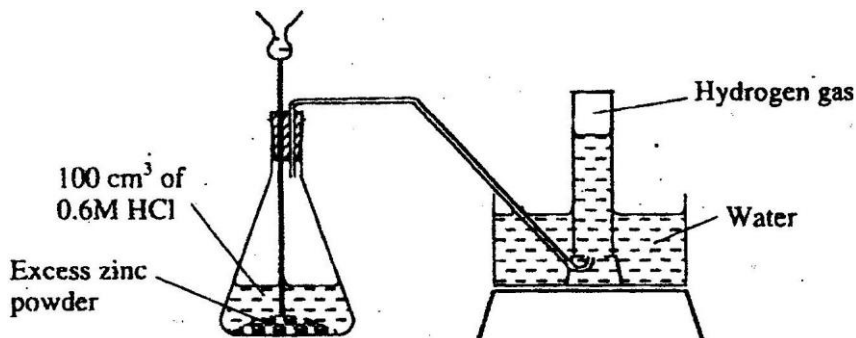

- (a) How would the final volume of hydrogen gas produced be affected if 80cm³ of 0,75 M hydrochloric acid was used? (1mk)
- (b) Give a reason why helium is increasingly being preferred to hydrogen in weather balloons.
26. The table below shows the number of valence electrons of the element P, Q and R.

Element	P	Q	R
Number of valence electrons	3	5	2

- (a) Explain why p and R would not be expected to form a compound. (1mk)
- (b) Write an equation to show the effect of heat on the carbonate of R (1mk)
- (c) Write the formula for the most stable ion or q. (1mk) 27. The diagram below formula for the most stable ion of Q. (1mk)

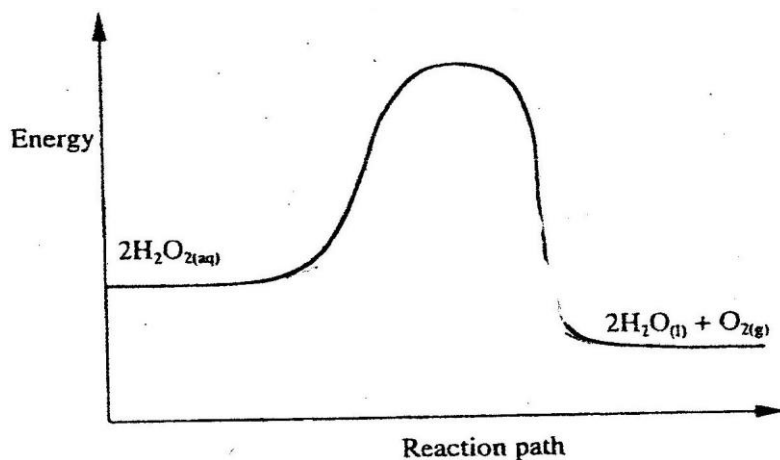

On the same axis, sketch the graph for the decomposition of hydrogen peroxide when manganese (IV) oxide is added. (2mks)

28. During the electrolysis of aqueous silver nitrate, a current of 5.0a was passed through the electrolysis for 3 hours.
- a) Write the equation for reaction which took place at the anode. (1mk)
- b) Calculate the mass of silver deposited ($A_g = 108$; $IF=96500C$) (2mks)

29 The diagram below is a section of a model of the structure of element T.

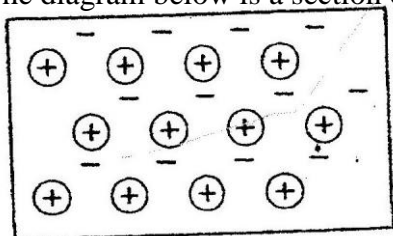

Key

- ⊕ Charged nucleus
- An electron

a) State the type of bonding that exists in T.

(1mk)

b) In which group of the period table does element T belong? Give a reason.

(2mks)

30. Below is a sketch of a graph showing the change in viscosity? (Ease of flow) with temperature when solid sulphur is heated.

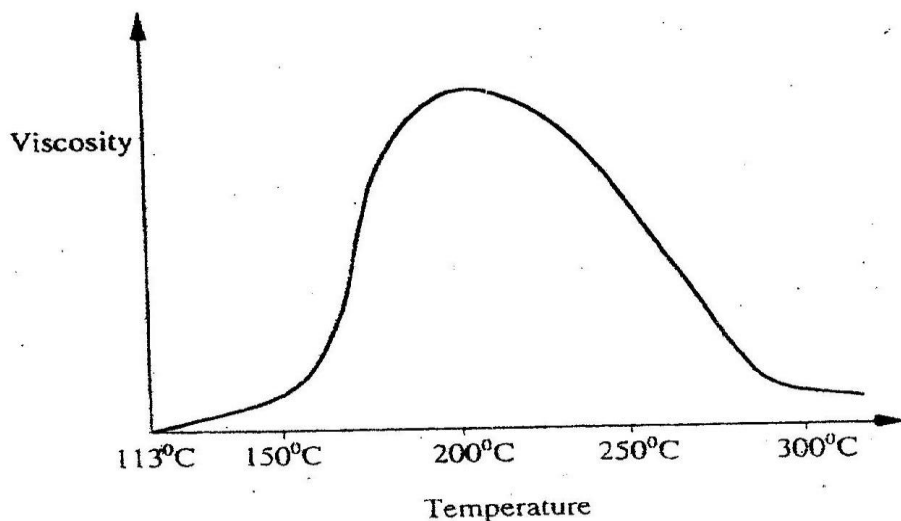

Describe what happens to the sulphur molecules when sulphur is heated from 150°C to about 200°C.

CHEMISTRY

Paper 2

THEORY Oct/Nov. 2007

- State two factors that should be considered when choosing fuel for cooking (2mks)
 - The diagram below represents a set – up that was used to determine the molar heat of

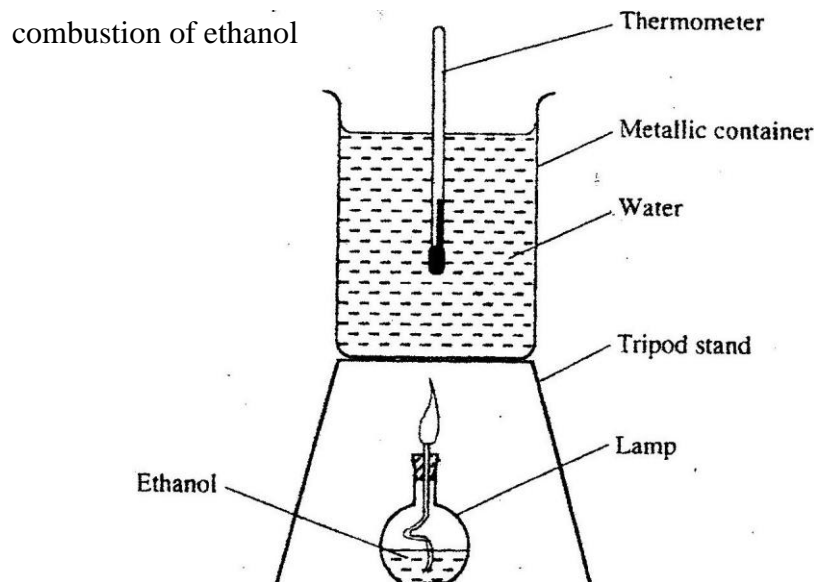

During the experiment, the data given below was recorded

Volume of water	450cm ³
Initial temperature of water	25 ⁰ C
Final temperature of water	46.5 ⁰ C
Mass of ethanol + Lamp before burning	125.5g
Mass of ethanol + lamp after burning	124.0g

Calculate the:

- Heat evolved during the experiment (density of water = 1g/cm³
Specific heat capacity of water = 4.2 Jg⁻¹K⁻¹) (3 mks)
- Molar heat of combustion of ethanol (C = 12.0, O = 16.0, H=1.0) (2 mks)
- Write the equation for the complete combustion of ethanol (1mk)
- The value of the molar heat of combustion of ethanol obtained in (b) (ii) above is lower than the theoretical value. State two sources of error in the experiment. (2 mks)

2. (a) Give the systematic names of the following compounds



(b) State the observations made when Propan – I- ol reacts with:

(i) Acidified potassium dichromate (VI) Solution (1mk)

(ii) Sodium metal (1mk)

(c) Ethanol obtained from glucose can be converted to ethane as shown below



Name and describe the process that take place in steps I and II

Step I (1 ½ mks)

Step II (1 ½ mks)

(d) Compounds A and B have the same molecular formula $\text{C}_3\text{H}_6\text{O}_2$. Compound A liberates carbon (IV) oxide on addition of aqueous sodium carbonate while compound B does not. Compound B has a sweet smell. Draw the possible structures of:

(i) Compound A (1 mark)

(ii) Compound B (1 mk)

(e) Give two reasons why the disposal of polymers such as polychloroethane by burning pollutes the environment. (2 mks)

3. The flow chart below shows a sequence of chemical reactions starting with copper study it and answer the questions that follow.

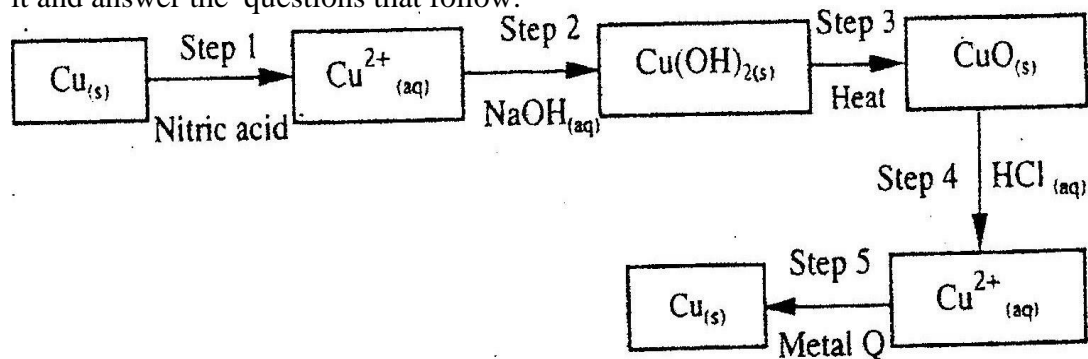

(a) In step 1, excess 3M nitric acid was added to 0.5g of copper powder

(i) State two observations which were made when the reactions was in progress (2mks)

(ii) Explain why dilute hydrochloric acid cannot be used in step 1 (1mk)

(iii) I Write the equation for the reaction that took place in step 1 (1mk)

II Calculate the volume of 3M nitric that was needed to react completely

with 0.5g of copper powder. (Cu = 63.5)

(3 mk)

- (b) Give the names of the types of reactions that took place in steps 4 and 5 (1 mk)

Step 4

Step 5

- (c) Apart from the good conductivity of electricity, state two other properties that make it possible for copper to be extensively used in the electrical industry. 2mks)

4. (a) Methanol is manufactured from carbon (IV) oxide and hydrogen gas according to the equation:

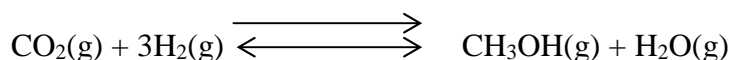

The reaction is carried out in the presence of a chromium catalyst at 700K and 30kPa. Under these conditions, equilibrium is reached when 2% of the carbon (IV) oxide is converted to methanol

- (i) How does the rate of the forward reaction compare with that of the reverse reaction when 2% of the carbon (IV) oxide is converted to methanol? (1 mk)
- (ii) Explain how each of the following would affect the yield of methanol:
- I Reduction (2mks)
- II Using a more efficient catalyst (2mks)
- (iii) If the reaction is carried out at 500K and 30kPa, the percentage of carbon (IV) oxide converted to methanol is higher than 2%

I what is the sign of ΔH for the reaction? Give a reason (2mks)

II Explain why in practice the reaction is carried out at 700K but NOT at 500K (1mk)

- (b) Hydrogen peroxide decomposes according to the following equation:

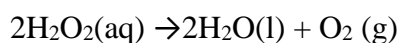

In an experiment, the rate of decomposition of hydrogen peroxide was found to be $6.0 \times 10^{-8} \text{ mol dm}^{-3} \text{ s}^{-1}$.

- (i) Calculate the number of moles per dm^3 of hydrogen peroxide that had decomposed within the first 2 minutes (2mks)

- (ii) In another experiment, the rate of decomposition was found to be $1.8 \times 10^{-7} \text{ mol dm}^{-3} \text{ s}^{-1}$. The difference in two rates could have been caused by addition of a catalyst. State, giving reasons, one other factor that may have caused the difference in two rates of decomposition (2mks)

5. (a) The diagram below represents part of the structure of a sodium chloride crystal.

The position of one of the sodium ions in the crystal is shown as \oplus

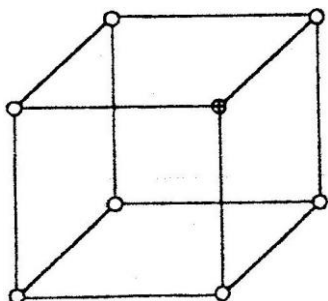

- (i) On the diagram, mark the position of the other three sodium ions (2 mks)
 (ii) The melting and boiling points of sodium chloride are 801°C and 1413°C respectively.

Explain why sodium chloride does not conduct electricity at 25°C , but does so at temperatures between 801°C and 1413°C (2 mks) (b)

- Give a reason why ammonia gas is highly soluble in water (2mks) (c) The structure of an

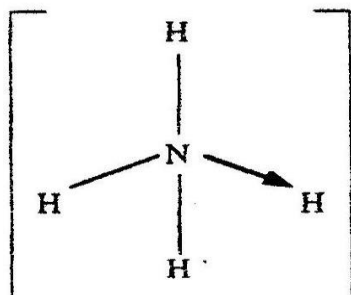

Name the type of bond represented in the diagram by $\text{N} \rightarrow \text{H}$ (1 mark)

- (d) Carbon exists in different crystalline forms. Some of these forms were recently discovered in soot and are called fullerenes

- (i) What name is given to different crystalline forms of the same element? (1mk)

- (ii) Fullerenes dissolve in methylbenzene while the other forms of carbon do not.

Given that soot is a mixture of fullerenes and other solid forms of carbon, describe how crystals of fullerenes can be obtained from soot. (3mks) (iii)

The relative molecular mass of one of the fullerenes is 720. What is the molecular formula of this fullerene? ($\text{C}=12.00$) (1 mk)

6. (a) The elements nitrogen, phosphorous and potassium are essential for plant growth.

(i) Potassium in fertilizers may be in the form of potassium nitrate
Describe how a sample of a fertilizer may be tested to find out if it contained nitrate ions. (2mks)

(ii) Calculate the mass of nitrogen present if a 25kg bag contained pure ammonium phosphate, $(\text{NH}_4)_2 \text{HPO}_4$. (N = 14.0, H=1.0, P = 31.0, O = 16.0) (2mks)

(b) The table below shows the solubility of ammonium phosphate in water at different temperatures.

Temperature (C ⁰)	Solubility of ammonium phosphate in g/100g water
10	63.0
20	69.0
30	75.0
40	82.0
50	89.0
60	97.0

(i) On the grid provided, draw the solubility curve of ammonium phosphate (Temperature on x – axis) (3 mks)

(ii) Using the graph, determine the solubility of ammonium phosphate at 25⁰C (1 mk)

(iii) 100g of a saturated solution of ammonium phosphate was prepared at 25⁰C

I what is meant by a saturated solution? (1mk)

II Calculate the mass of ammonium phosphate which was used to prepare the saturated solution (2 mks)

(c) The graph below shows how the PH value of soil in a farm changed over a period of time

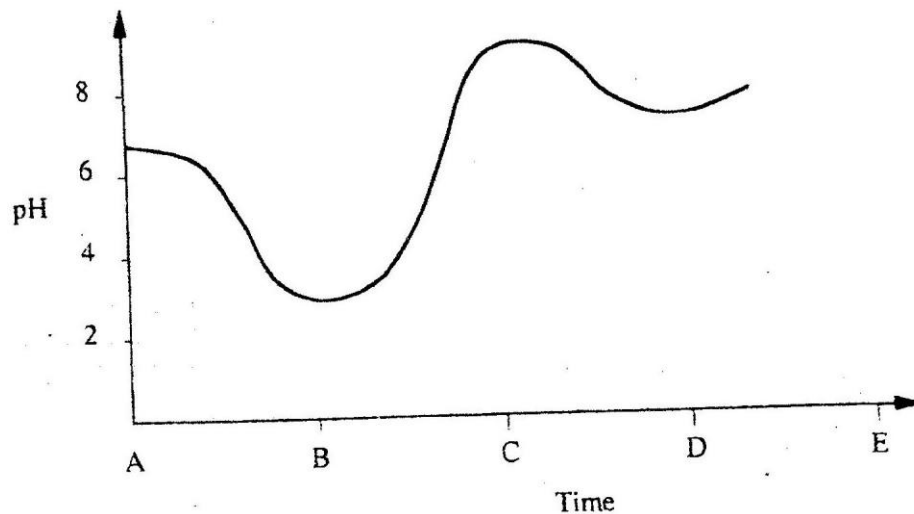

- (i) Describe how the pH of the soil can be determined (2mks)
- (ii) State one factor that may have been responsible for the change in the soil pH in the time interval AB (1 mk)

7. The diagram below shows the set up used in an experiment to prepare chlorine gas and react it with aluminium foil. Study it and answer the question that follow

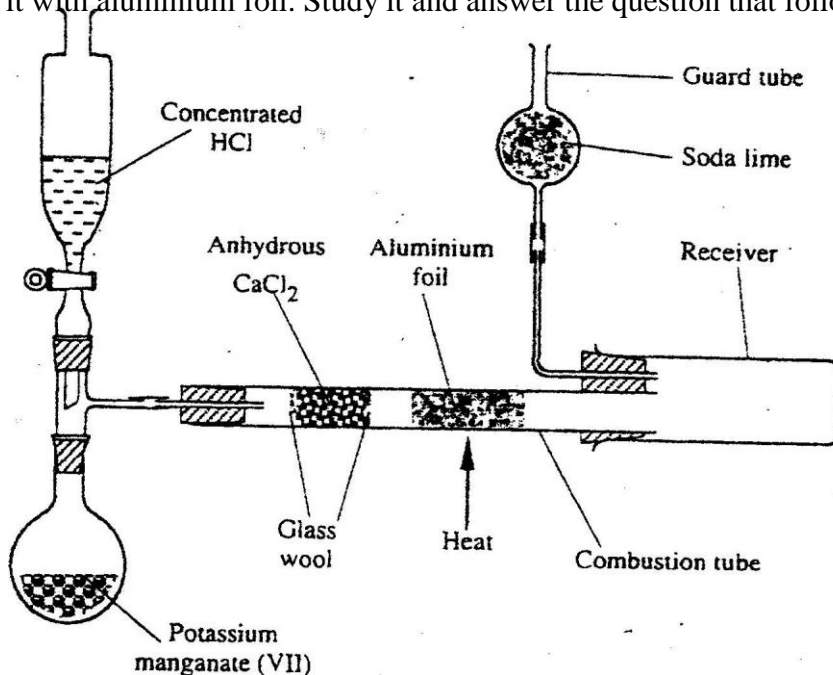

- (a) In the experiment, concentrated hydrochloric acid and potassium manganate (VII) were used to prepare chlorine gas. State two precautions that should be taken in carrying out this experiment. (2mks)
- (b) Write the formula of another compound that could be used instead of potassium manganate (VII) (1 mk)
- (c) Explain why it is necessary to allow the acid to drip slowly onto potassium manganate (VII) before the aluminium foil is heated. (2 mks)
- (d) State the property of the product formed in the combustion tube that makes it possible for it to be collected in the receiver (1mk)
- (e) When 1.08g of aluminum foil were heated in a stream of chlorine gas, the mass of the product formed was 3.47 g Calculate the:
- (i) Maximum mass of the product formed if chlorine was in excess; (Al= 27; Cl = 35.5)
- (ii) Percentage yield of the product formed (1 mk)
- (f) Phosphorous trichloride is a liquid at room temperature. What modification should be made to set up if it is to be used to prepare phosphorous trichloride? (1 mk)

OCT/NOV. 2008

2 HOURS

1. A small crystal of potassium manganate (VII) was placed in a beaker water. The beaker was left standing for two days without shaking. State and explain the observations that were made. (2mks)
2. When a hydrated sample of calcium sulphate $\text{CaSO}_4 \cdot \text{XH}_2\text{O}$ was heated until all the water was lost, the following data recorded;

Mass of crucible = 30.296 g

Mass of crucible +hydrated salt = 33.111 g

Mass of crucible + anhydrous salt = 32.781 g

Determine the empirical formula of the hydrated salt (Relative formula mass of $\text{CaSO}_4 = 136$, $\text{H}_2\text{O} = 18$). (3mks)

3. Complete the following table by filling in the missing test and observations (3mks)

No.	Gas	Test	Observation
I	Chlorine	Put a moist red litmus into the gas	
II	Sulphure (IV) oxide		Paper turns green
III	Butane	Add a drop of bromin water	e

4. The structure of a detergent is

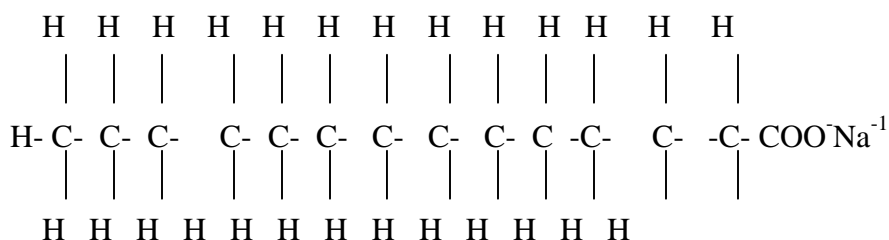

- a) Write the molecular formula of the detergent. (1mk)
- b) What type of detergent is represented by the formula? (1mk)
- c) When this type of detergent is used to wash linen in hard water, spots (marks) are left on the linen. Write the formula of the substance responsible for the spots (1mk)

5. Phosphoric acid is manufactured from calcium phosphate according to the following equation.

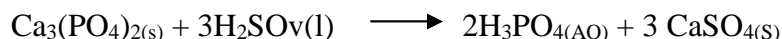

Calculate the mass in (Kg) of phosphoric acid that would be obtained if 155 Kg of calcium phosphate reacted completely with the acid

(Ca=40, P=31, S=32, O=16, H=1)

(2mks)

6. The structure below represents a sweet smelling compound

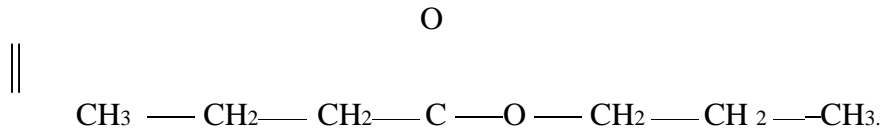

Give the names of the two organic compounds that can be used to prepare this compound in the laboratory. (2mks)

7. a) What are isotopes? (1mk)

- b) Determine the number of neutrons in ${}_{8}^{18}\text{O}$.

${}_{8}^{18}\text{O}$

(1mk)

8. a) State the observation made at the end of the experiment when a mixture of iron powder and sulphur is heated in a test tube. (1mk)

- b) Write an equation for the reaction the product in (a) above and dilute hydrochloric acid. (1mk)

- c) When a mixture of iron powder and sulphur is heated, it glows more brightly than that of iron fillings and sulphur. Explain this observation

(1mk)

9. Zinc reacts with both concentrated and dilute sulphuric (VI) acid. Write equations for two reactions. (2mk)

10. When magnesium was burnt in air, a solid mixture was formed. On addition of water to the mixture a gas which turned moist red litmus paper blue was evolved. Explain these observations.

11. The table below gives atomic numbers of elements represented by the letters A, B, C and D.

Element	A	B	C	D
Atomic number	15	16	17	20

Use the information to answer the questions that follow.

- a) Name the type of bonding that exists in the compound formed when A and D react (1mk)

- b) Select the letter which represents the best oxidizing agent. Give a reason for your answer. (2mks)

12. In an experiment, a test-tube full of chlorine water was inverted in chlorine water as shown in the diagram below and the set up left in sunlight for one day.

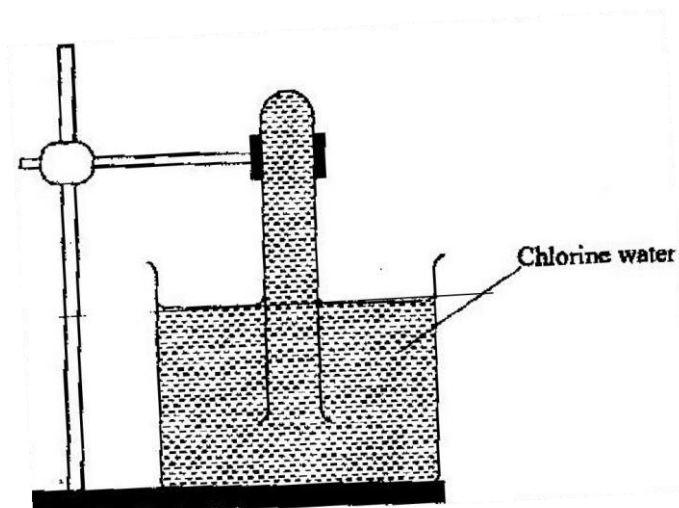

- After one day, a gas was found to have collected in the test-tube
- Identify the gas.
 - What will happen to the PH of the solution in the beaker after one day? Give an explanation. (2mks)

13. In a laboratory experiment hydrogen gas was passed over heated copper (II) oxide as shown the diagram below.

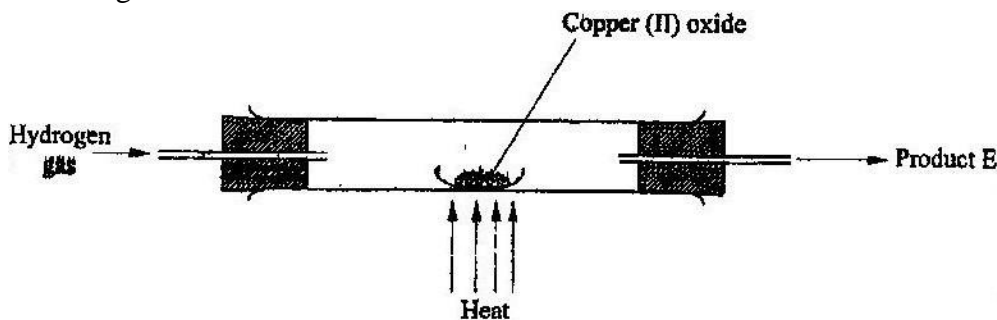

Describe a chemical test that can be used to identify the product e. (2mks)

14. Samples of urine from three participants F, G and H at an international sports meeting were spotted onto a chromatography paper alongside two from illegal drugs A₁ and A₂.

A chromatogram was below shows the

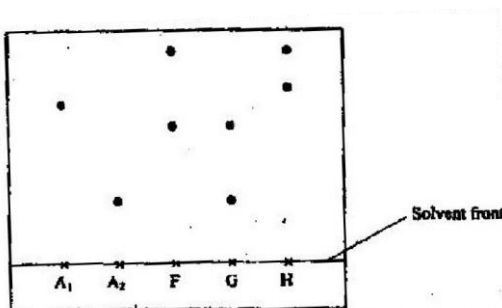

run using methanol. The figure chromatogram.

- Identify the athlete who had used an illegal drug. (1mk)
- Which drug is more soluble in methanol? (1mk)

15. The table below gives the solubilities of substances J, K and L at different temperatures

Substance	Solubility in grammes per 100 g water at			
	0°C	20°C	40°C	60°C
J	0.334	0.16	0.097	0.0058
K	27.60	34.0	40.0	45.5
L	35.70	36.0	40.0	37.3

Select the substance which, when dissolved in water, heat is given out. Give a reason
(2mks)

16. Starting with copper metal, describe how a sample of crystals of copper (II) chloride may be prepared in the laboratory. (3mks)

17. A compound whose general formula is $M(OH)_3$ reacts as shown by the equation below.

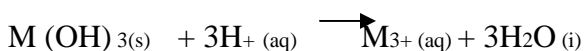
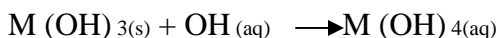

- (a) What name is given to compounds which behave like $M(OH)_3$ in the two Reactions (1 mk)
- (b) Name two elements whose hydroxides behave like that of M (2 mks)
18. The grid below is part of the periodic table. Use it to answer the questions that follow, (the letters are not the actual symbols of the elements).

					R	S	
N	Q					T	U
P							

- a) Indicate on the grid the position of an element represented by letter V whose atomic number is 14. (1mk)
- b) Select a letter which reaction between Q and T. (1mk)
19. Select a letter which represents a mono atomic gas. (1mk)

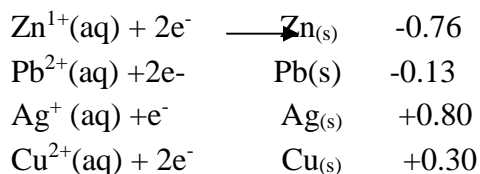

- a) Write the cell representation for the electrochemical cell that would give the highest E (1mk)
- b) State and explain the observations made when a copper rod is placed in a beaker containing silver nitrate solution. (2mks)
20. a) State the Graham's law diffusion. (1mk)
- b) The molar masses of gases W and X are 16.0 and 44.0 respectively. If the rate of diffusion of W through a porous material is $12\text{cm}^3\text{s}^{-1}$ calculate the rate of diffusion of X through the same material. (2mks)

21. The diagram below represents an experiment that was set up to investigate movement of ions during electrolysis.

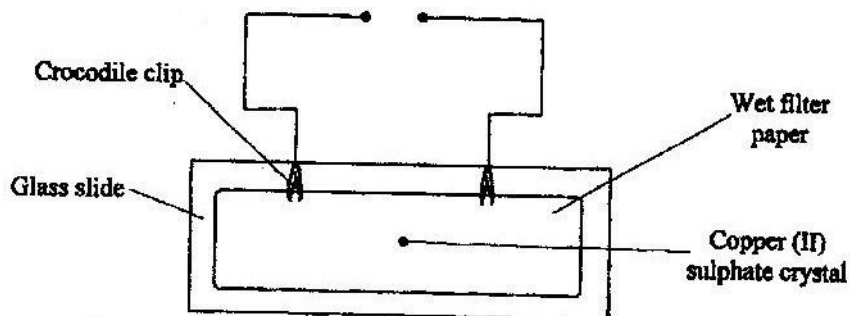

When the circuit was completed, it was noticed that a blue colour spread towards the right.

- a) Explain this observation (2mks)
- b) Write the equation for the reaction that occurred at the anode. (1mk)

22. The diagram below is part of a set up used in the laboratory preparation of a gas.

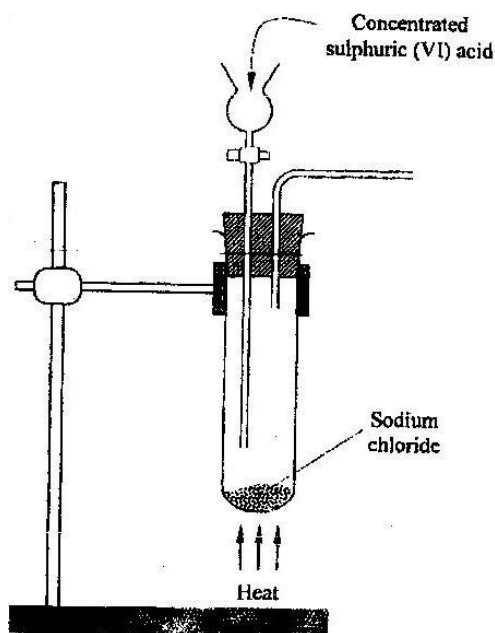

Complete the diagram to show how a dry sample of the gas can be collected.

(3mks) 23.

In a closed system, aqueous iron (III) chloride reacts with sulphide gas as shown in the equation below.

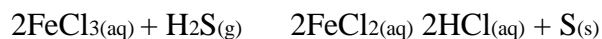

State and explain the observation that would be made if dilute hydrochloric acid is added to the system at equilibrium. (2mks)

24. a) A radioactive substance emits three different particles.
Give the symbol of the particle with the highest mass. (1mk)

b) (i) Find the values of Z_1 and Z_2 in the nuclear equation below

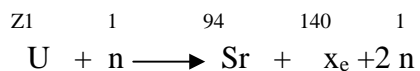

92 0 38 Z0 0 iii) What type of nuclear reaction is represented in represented in b (i) above? (1mk)

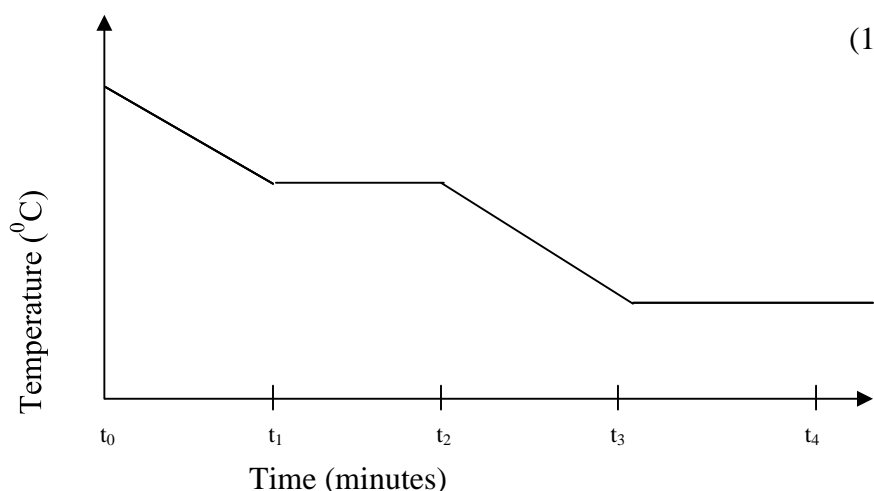

Give the name of the:

a) Process taking place between t_0 and t_1 . (1mk)

b) Energy change that occurs between t_3 and t_4

26. When solid B_1 was heated, a gas which formed a white precipitate when passed through lime water was produced. The residue was dissolved in dilute nitric (V) acid to form a colourless solution B_2 . when dilute hydrochloric acid was added to solution B_2 a white precipitate which dissolved on warming was formed. a) Write the formula of the;

I Cation in solid B_1 (1mk)

II anion in solid B_1 (1mk)

b) Write an ionic equation for the reaction between the residue and dilute nitric (V) acid. (1mk)

27. In an experiment to determine the percentage of magnesium hydroxide in an anti-acid, a solution containing 0.50 g of the anti-acid was neutralized by 23.0 cm³ of 0.010m hydrochloric acid (Relative formula mass of magnesium hydroxide =58)

a) Mass of magnesium hydroxide in the anti-acid; (2mks)

b) Percentage of magnesium hydroxide in the anti-acid (1mk)

28. During the extraction of aluminium from its ores; the ore is first purified to obtain

Molten Alumina

alumina.

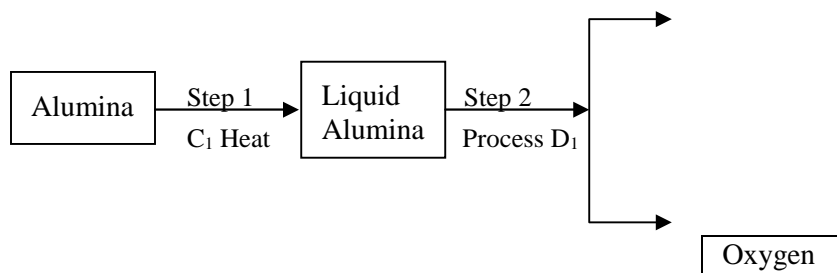

- a) Name
- (i) Substance C₁ (1mk)
- (ii)
- Process D₁ (1mk)
-
- b) Give two reasons why aluminium is used extensively in the making of cooking pans. (1mk)

29. A certain mass of a metal E₁ reacted with excess dilute hydrochloric acid at 25°C. The volume of hydrogen gas liberated was measured after every 30 seconds. The results were presented as shown in the graph below.

- a) Name one piece of apparatus that may have been used to measure the volume of gas liberated. (1mk)
- b) (i) On the same axis, sketch the curve that would be obtained if the experiment was repeated at 35°C. (1mk)
- (ii) Explain the shape of your curve in b(i) above. (1mk)

30. Crude oil contains sulphur. What would be the effect to the environment of using fuel containing sulphur? (1mk)

31. Study the flow chart below and answer the questions that follow.

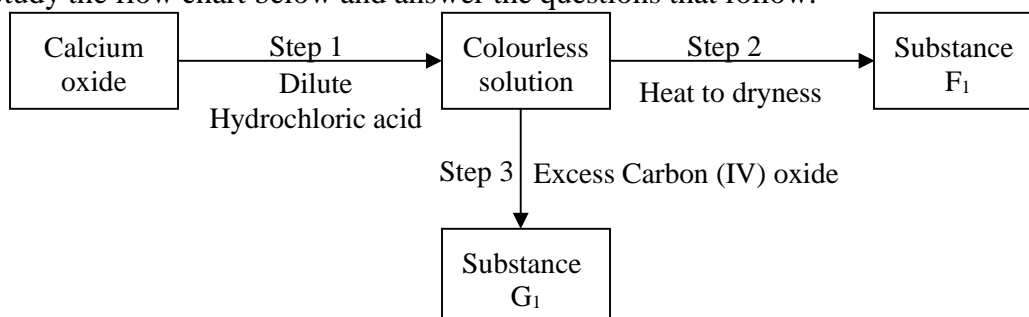

- a) Give the name of the process that takes place in step 1. (1mk)

- b) Give;
- (i) The name of substance G_1
 - (ii) One use of substance F_1

CHEMISTRY PAPER 2 THEORY

OCT /NOV. 2008

233/2

2 HOURS

1. a) Biogas is a mixture of mainly carbon (IV) oxide and methane.
- (i) Give a reason why biogas can be used as a fuel. (1mk)
 - (ii) Other than fractional distillation, describe a method that can be used to determine the percentage of methane in biogas. (3mks)
- b) A sample of biogas contains 35.2% by mass of methane. A biogas cylinder contains 5.0 kg of the gas.
Calculate the;
- (i) Number of moles of methane in the cylinder. (Molar mass of methane=16)
(2mks)
 - (ii) Total volume of carbon (IV) oxide produced by the combustion of methane in the cylinder (Molar gas Volume= 24.0 dm^{-3} at room temperature and pressure).
(2mks)
- c) Carbon (IV) oxide, methane, nitrogen (I) oxide and trichlorofluoromethane are green-house gases.
- (i) State one effect of an increased level of these gases to the environment.
(1mk)
 - (ii) Give one source from which each of the following gases is released to the environment;

I	Nitrogen (i) oxide	(1mk)
II	Trichlorofluoromethane.	(1mk)

- 2 a) Write an equation to show the effect of heat on the nitrate of:

(i) Potassium (1mk)

- b) The table below gives information about elements $A_1A_2A_3$, and A_4

Element	Atomic Number	Atomic Radius (nm)	Ionic radius (nm)
A_1	3	0.134 0.090	0.074 0.012
A_2	5	0.143	0.050
A_3	13	0.099	0.181
A_4	17		

- (i) In which period of the periodic table is element A_2 ? Give a reason

(2 mks)

(ii) Explain why the atomic radius of:

I A_1 is greater than that of A_2 ;

II A_4 is smaller than its ionic radius (2 mks)

(iii) Select the element which is in the same group as A_3 (1 mk)

(iv) Using dots (.) and crosses(x) to represent outermost electrons. Draw a diagram to show the bonding in the compound formed when A_1 reacts with A_4

(1 mk)

3. (a) Describe the process by which Nitrogen is obtained from air on a large scale.

(4 mks)

(b) Study the flow chart below and answer the questions that follow.

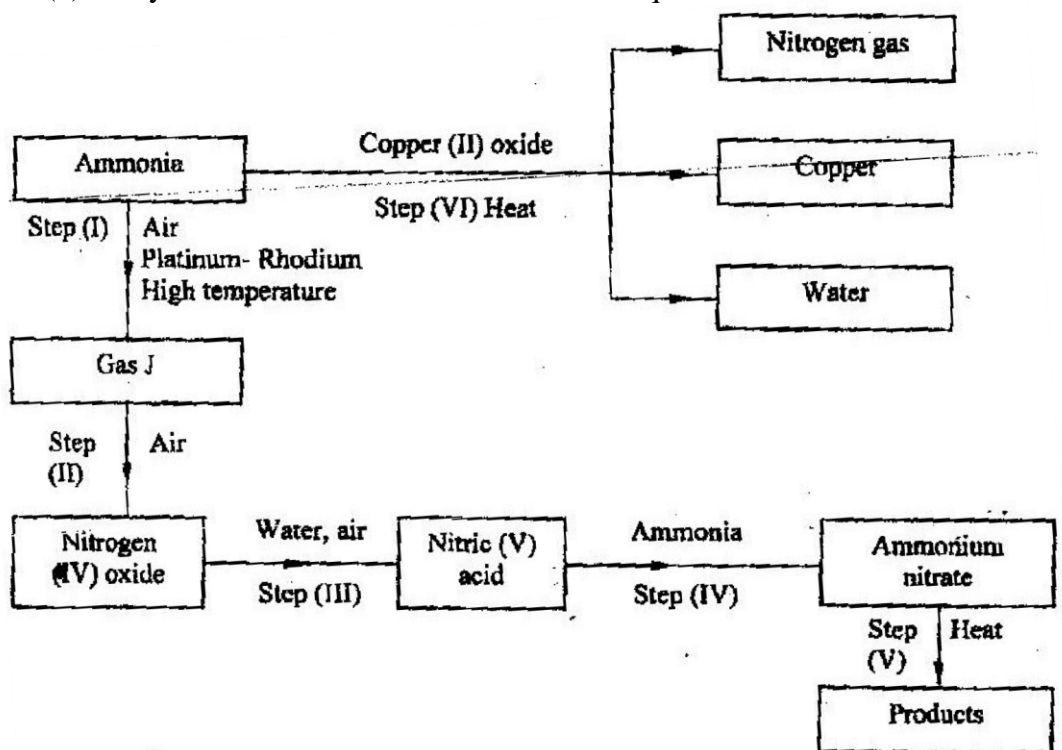

(i) Identify gas J. (1 mk)

(ii) Using oxidation numbers, show that ammonia is the reducing agent in step (VI)

(2mks)

(iii) Write the equation for the reaction that occurs in step (V). (1mk)

(iv) Give one use of ammonium nitrate. (1mk)

c) The table below shows the observations made when aqueous ammonia was added to cations of elements F and G until in excess.

Cation of	Addition of a few drops of Aqueous ammonia.	Addition of excess aqueous ammonia.
E	White precipitate	Insoluble

F	No precipitate	No precipitate
G	White precipitate	Dissolves

- (i) Select the cation that is likely to be Zn^{2+} (1mk)
- (ii) Given that the formula of the cation of element E is E^{2+} , write the ionic equation for the reaction between $E^{2+}_{(aq)}$ and aqueous ammonia. (1mk)
- 4a) (i) State the Le chatelier's principle. (1mk)
- (ii) Carbon (II) oxide gas reacts with steam according to the equation;
 $CO_{(g)} + H_2O_{(g)} \rightleftharpoons H_2_{(g)} + CO_{2(g)}$
 What would be the effect of increasing the pressure of the system at equilibrium? Explain. (2mks)
- b) The table below gives the volumes of oxygen gas produced at different times when hydrogen peroxide decomposed in the presence of a catalyst.
- | | | | | | | | |
|-----------------------------|---|----|----|-----|-----|-----|-----|
| Time(Sec) | 0 | 10 | 20 | 30 | 40 | 50 | 60 |
| Volume of oxygen (cm^3) | 0 | 66 | 98 | 110 | 119 | 120 | 120 |
- (i) Name the catalyst used for this reaction (1mk)
- (ii) On the grid provided, draw the graph of volume of oxygen gas produced (vertical axis) against time. (3mks)
- (iii) Using the graph, determine the rate of decomposition of hydrogen peroxide after 24 seconds. (2mks)
- (iv) Give a reason why the total volume of oxygen gas produced after 50 seconds remains constant. (1mk)
5. (a) Alkanes, alkenes and alkynes can be obtained from crude oil. Draw the structure of the second member of the alkyne homologous series. (1mk)
- (b) Study the flow chart below and answer the questions that follow

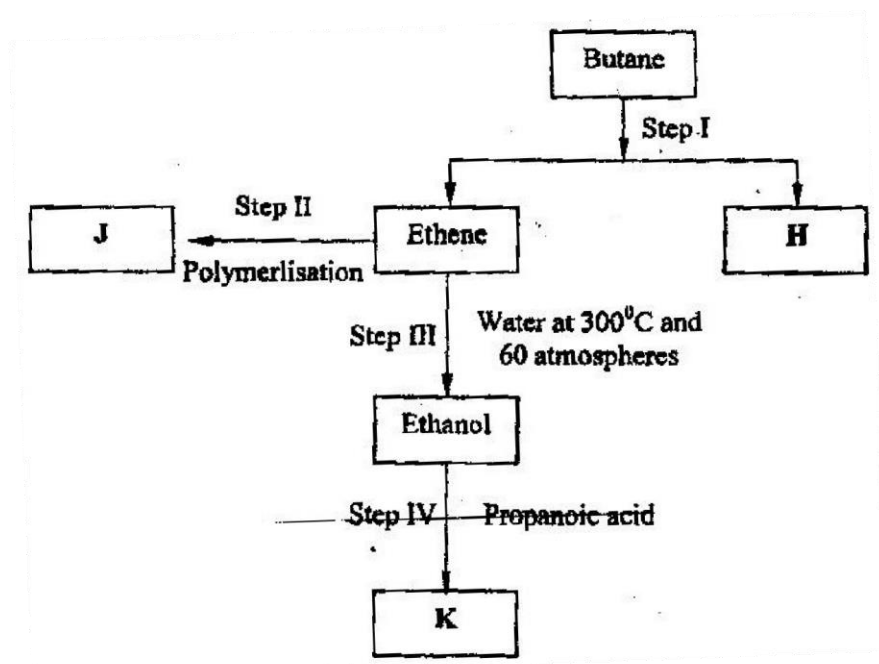

(i) State the conditions for the reaction in step 1 to occur (1 mk) (ii) Identify substance H (1 mk)

(iii) Give:

- I. One advantage of the continued use of substance such as J (1 mk)
- II The name of the process that takes place in step III (1 mk)
- III The name and the formula of substance K (2mks)

Name:.....

Formula:.....

(iv) The relative molecular mass of J is 16,800. Calculate the number of monomers that make up J.

(c) The table below give the formula of four compounds L,M,N and P

Compound	Formula
L	C ₂ H ₆ O
M	C ₃ H ₆
N	C ₃ H ₆ O ₂
P	C ₃ H ₈

Giving a reason in each case, select the letter which represents a compound that:

- (i) Decolorizes bromine in the absence of UV light (2 mks)
- (ii) Gives effervescence when reacted with aqueous sodium carbonate (2 mks)

6. The diagram below represents a set up that can be used to electrolyze aqueous copper (II) sulphate.

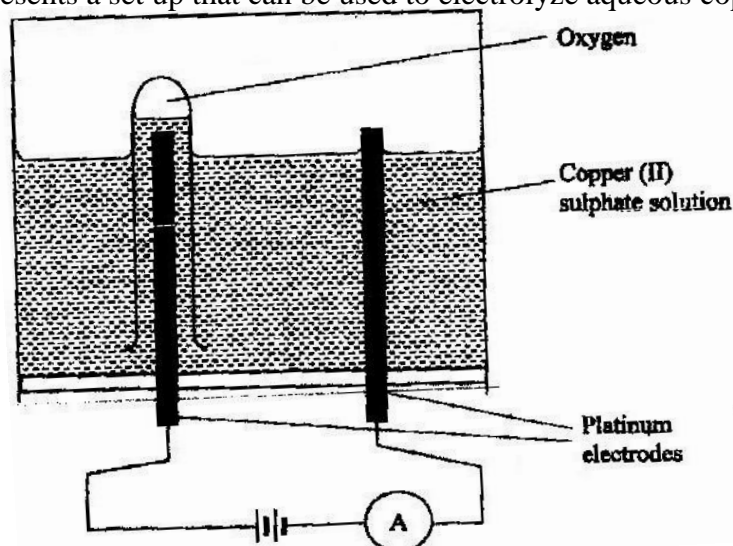

- (a) (i) Describe how oxygen gas is produced during the electrolysis (2 mks)
 (ii) Explain why copper electrodes are not suitable for this electrolysis (2 mks)
- (b) Impure copper is purified by an electrolytic process
- (i) Name one ore from which copper is obtained (1 mk)
 (ii) Write the equation for the reaction that occur at the cathode during the purification of copper (1 mk)
 (iii) In an experiment to electroplate a copper spoon with silver, a current of 0.5 A was passed for 18 minutes. Calculate the amount of silver deposited on the spoon ($\pi = 96500$ coulombs, $Ag = 108$) (3mks)
 (iv) Give two reasons why some metals are electroplated (2mks)
7. (a) Define the standard enthalpy of formation of a substance (1 mk)
 (b) Use the thermo chemical equations below to answer the questions that follow.
1. $C_2H_6(g) + \frac{7}{2} O_2(g) \rightarrow 2CO_2(g) + 3H_2O(l)$; $\Delta H_1 = -1560 kJ mol^{-1}$
 2. $C_{(graphite)} + O_2(g) \rightarrow CO_2(g)$; $\Delta H_2 = -394 kJ mol^{-1}$
 3. $H_2(g) + \frac{1}{2} O_2(g) \rightarrow H_2O(g)$ $\Delta H_3 = -286 kJ mol^{-1}$
- (i) Name two types of heat changes represented by ΔH_3 (2 mks)
 (ii) Draw an energy level diagram for the reaction represented by equation 1
 (iii) Calculate the standard enthalpy of formation of ethane (2 mks)
 (iv) When a sample of ethane was burnt, the heat produced raised the temperature of 500g of water by 21.5 K, (specific heat capacity of water = $4.2 J g^{-1} K$).
 Calculate the:

- I. Heat change for the reaction (2 mks)
- II. Mass of ethane was burnt. (relative formula mass of ethane= 30)
(2 mks)

CHEMISTRY 2009

PAPER 1

1. The ionization energies for three elements A, B and C are shown in the table below:

Element	A	B	C
Ionisation energy (kJ/mole)	519	418	494

- a) what is meant by ionization energy? (1 mk)
- b) which element is the strongest reducing agent? Give a reason. (2 mks)
2. Hardness of water may be removed by either boiling or addition of chemicals
- a) write an equation to show how boiling removes hardness of water. (1 mk)
- b) name two chemicals that are used to remove hardness of water. (2 mks)
3. The atomic number of sulphur is 16.

Write the electron arrangement of sulphur in the following:

(2 mks)

a) H_2S ;

b) SO_2

4. An experiment was set up as shown in the diagram below:

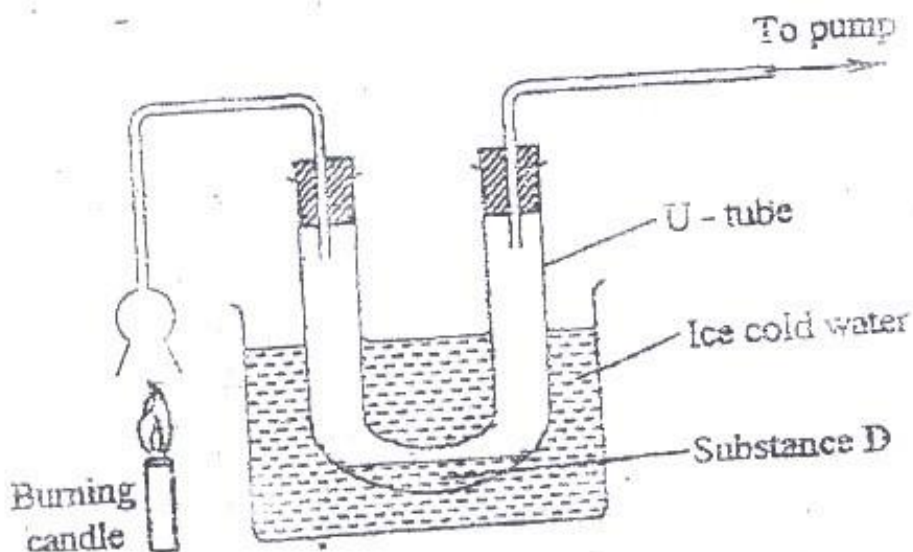

a)

Identify substance D.

(1 mk)

b) Describe how the other product of the burning candle could be prevented from getting into the environment.

(2

mks)

5. In terms of structure and bonding, explain why the melting point of oxygen is much lower than that of sodium. (3 mks)

6. An isotope of element E has 34 neutrons and its mass number is 64. E forms a cation with 28 electrons. Write the formula of the cation with 28 electrons. Write the formula of the cation indicating the mass and atomic numbers. (1mk)

7. When aluminium oxide was electrolysed, 1800kg of aluminium metal were obtained.

a) Write equation for the formation of aluminium metal (1 mk)

b) Calculate the quantity of electricity in faradays used (Al=27) (2 mks)

8. Using dots (.) and crosses (x), show bonding in:

a) The compound formed when nitrogen reacts with fluorine

(Atomic numbers F=9, N=7); (1mk)

b) Sodium oxide.

(Atomic numbers Na= 11, O = 8) (1 mk)

9. a) what is meant by molar heat of solution? (1 mk)

b) the lattice energy of sodium bromide and hydration energies of sodium and bromide ions are: $733,406$ and 335 kJmol^{-1} respectively.

i) Complete the energy cycle diagram below by inserting the values of

∇H_1 , ∇H_2 , and ∇H_3

(1 ½

mks)

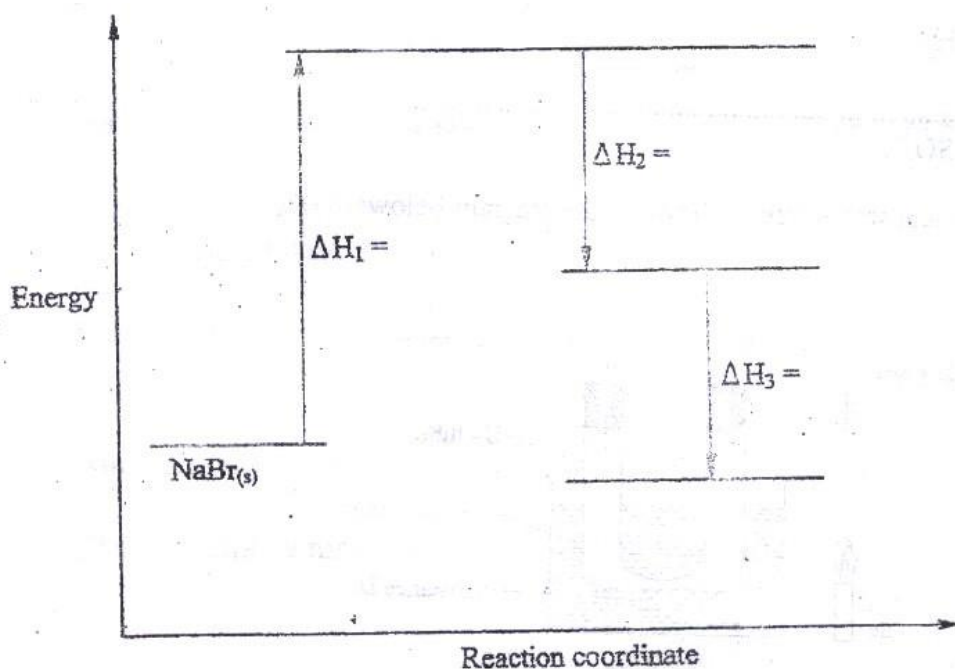

ii) Determine the molar heat of solution of solid sodium bromide. (½ mk)

10. Hydrogen and oxygen can be obtained by electrolysis of acidified water.

Using equations for the reactions at the electrodes, explain why the volume of

hydrogen obtained is twice that of oxygen.

(2mks)

11. Starting with 50 cm³ of 2.8M sodium hydroxide, describe how a sample of pure sodium sulphate crystals can be prepared. (3

mks)

12. The standard reduction potentials of two half –cells are:

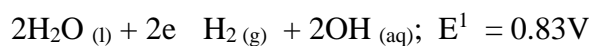

Draw a labelled diagram of an electro chemical cell that can be constructed using

the two half –cells

(3

mks)

13. When 8.53 of sodium nitrate were heated in an open test-tube the mass of oxygen gas produced was 0.83 g . Given the equation of the reaction as



Calculate the percentage of sodium nitrate that was converted to sodium nitrite

(Na = 23.0 N = 14.0 O = 16.0)

(3

mks)

14. a) Draw and name the structure of the compound formed when one mole of ethyne reacts with one mole of hydrogen bromide. (2mks)

b) Draw the structures of the alkynes whose molecular formula is C_4H_6 (1 mk)

15.

- a) student used the set up shown in the diagram below in order to study the reactions of some metals with steam. The experiment was carried out for ten minutes

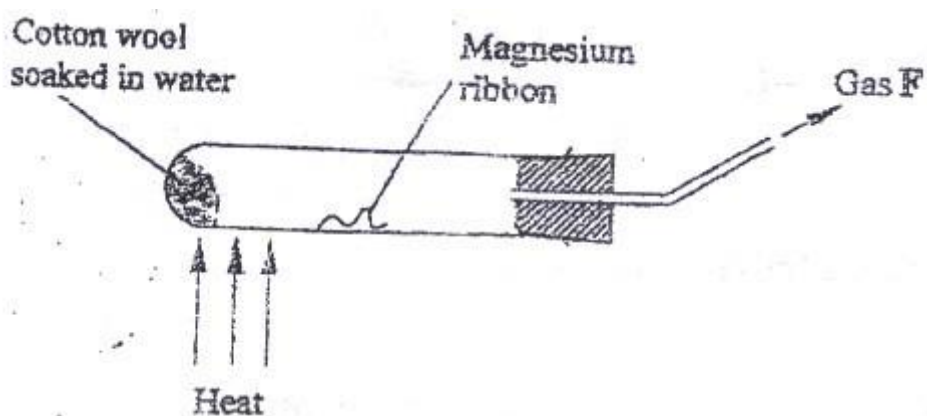

- a) What observation would be made if gas F is ignited? (1 mk)
- b) When the experiment was repeated using iron powder instead of magnesium ribbon very little gas F was obtained.

- i) Give a reason for this observation (1 mk)

16.

- ii) What change in the conditions of the experiment should the student have made in order to increase the volume of gas F Produced?

(1mk)

The solubility curve of potassium nitrate is shown below.

- a) Determine the solubility of potassium nitrate at 50⁰C (1 mk)

- b) Determine the molar concentration of saturated potassium nitrate at 50⁰C

(K=39.0 O= 16.0 N= 14.0 and density of water 1 g/cm³). (2 mks)

17.

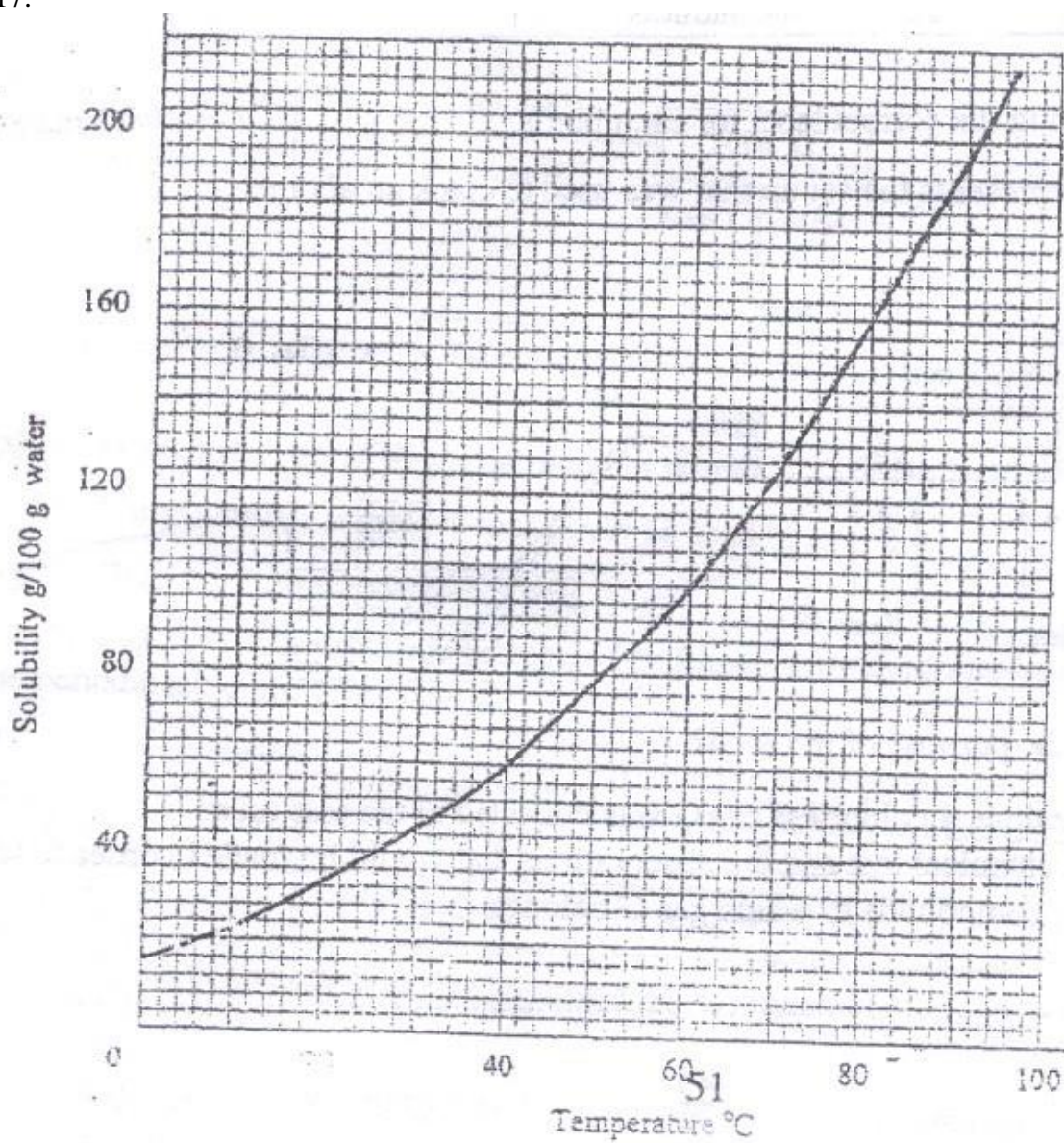

The structure of methanoic acid is

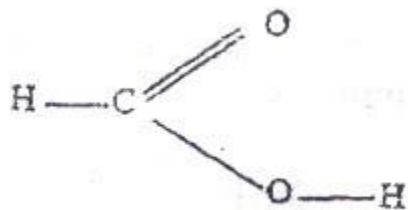

18.

What is the total number of electrons used for bonding in a molecule of methanoic acid? Give reasons. (2 mks)

18. Bottles of sodium carbonate, sodium chloride and sugar have lost their labels. A student prepares and tests an aqueous solution of a sample from each bottle.

The results obtained are as shown in the table below.

Bottle	PH	Electrical Conductivity	Correct label
1	7	Conducts	
2	7	Does not conduct	
3	10	conducts	

Complete the table by filling the correct label for each bottle. (3 mks)

19) The figure below represents the set up that was used to crack an alkane.

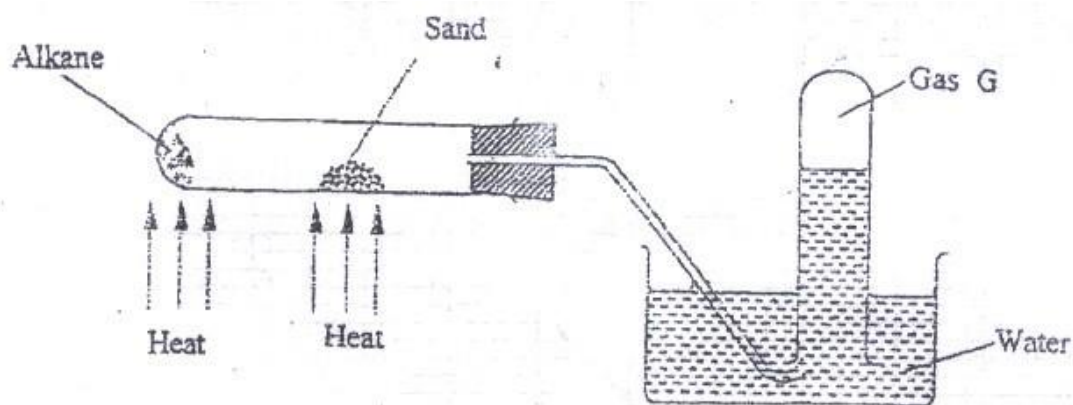

- a) What was the purpose of the sand? (1 mk)
- b) After some time, a colourless gas G collected in the test-tube. Describe a chemical test and the observations that would be made in order to identify the class of compounds to which gas G belongs.

(2 mks)

20. Classify the following processes as either chemical or physical. (3 mks)

Process	Type of change
a) Heating copper (II) sulphate crystals	
b) Obtaining kerosene from crude oil	

c) Souring of milk	
--------------------	--

21. Give the name of the product formed when magnesium reacts with phosphorus.

(1

mk)

22. a student added very dilute sulphuric (VI) acid to four substances and recorded the observations shown in the table below.

Test	Substance	Gas given off
1	Sodium	Yes
2	Iron	No
3	Carbon	Yes
4	Copper	No

For which tests are the observations wrong? Explain

(3 mks)

23. Use the flow chart below to answer the questions that follow.

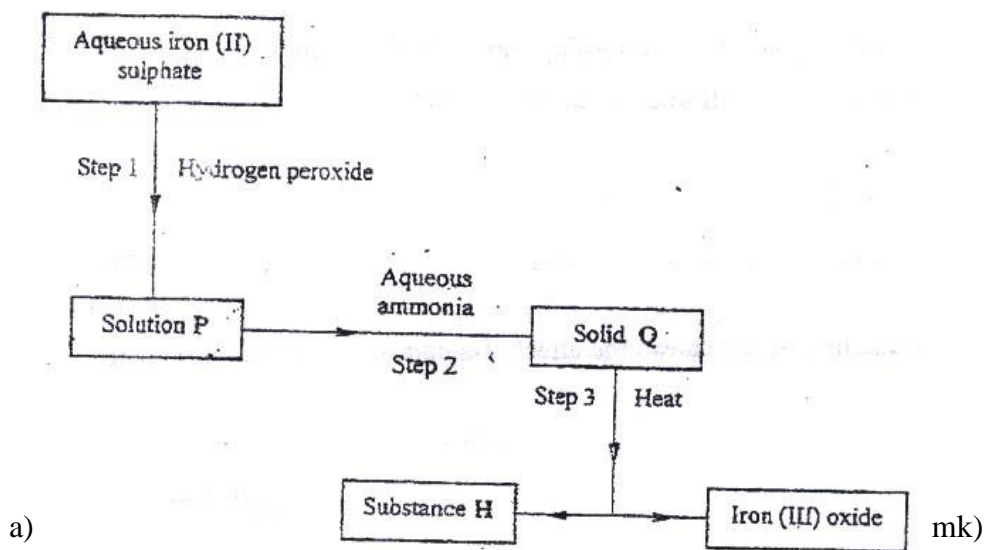

b) Name another substance that could be used in step 2. (1 mk)

c) Give the name of substance H. (1 mk)

24. The boiling points of some compounds of hydrogen with some elements in groups 4 and 6 of the periodic table are given below.

Compound	Boiling point (^o C)	Compound	Boiling point(^o C)
CH ₄	-164.0	H ₂ O	100.0
SiH ₄	-112.0	H ₂ S	-61.0

- a) Which of the compounds CH₄ and SiH₄ has stronger intermolecular forces? (1 mk)
- b) Explain why the boiling points of H₂O and H₂S show different trends from that of CH₄ and SiH₄ (2mks)

25. For each of the following reactions, state the observation and write the formula of the

Compound responsible for the observation:

a) Bromine water is added to aqueous potassium iodide; (1 ½ mks)

b) Excess aqueous ammonia is added to copper (II) hydroxide (precipitate).

(1 ½ mks)

26. The graph below shows the relationship between pressure and the temperature of

a

gas in a fixed volume container.

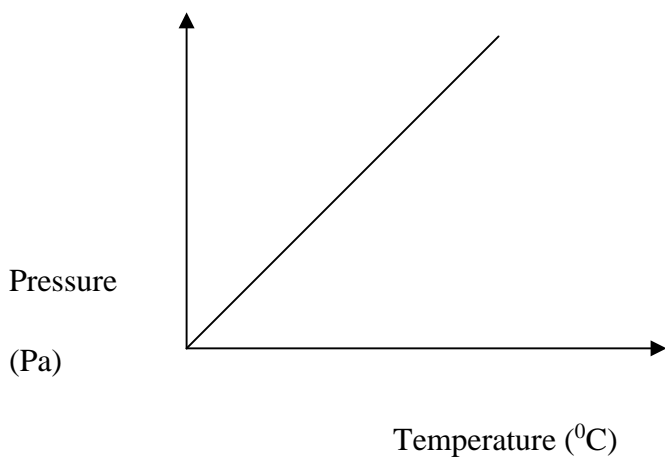

a) State the relationship between pressure and temperature that can be deduced

from the graph.

(1 mk)

b) Using kinetic theory, explain the relationship shown in the graph. (2 mks)

27. The following reaction is in equilibrium in a closed container

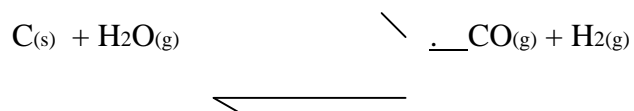

State giving reasons how an increase in pressure would affect the amount of

hydrogen.

(2 mks)

28. The energy level diagram below shows the effect of a catalyst on the reaction path.

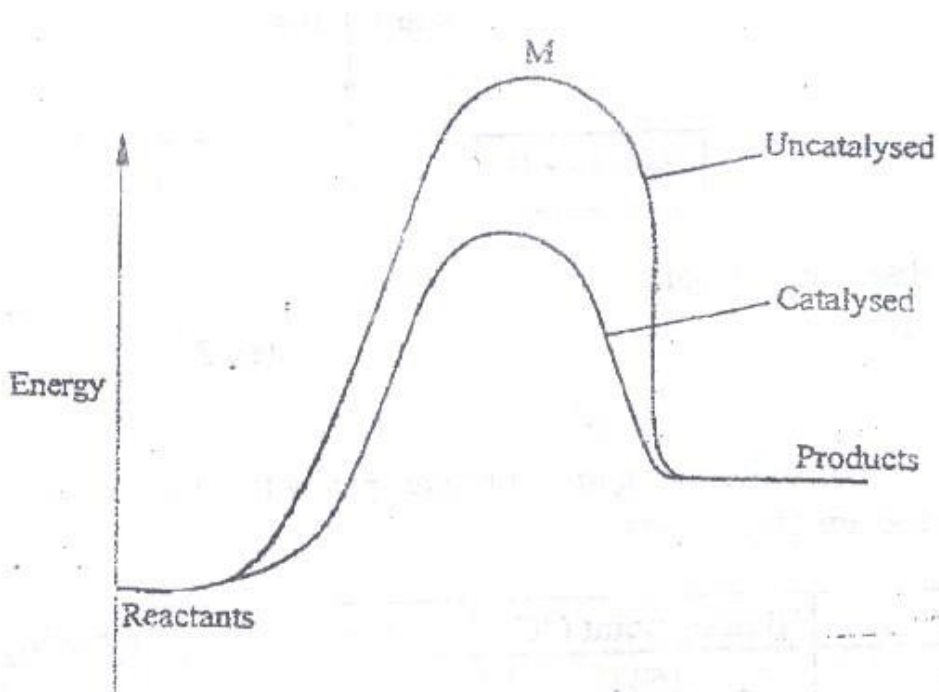

a) What does point M represent? (1 mk) **CHEMISTRY**

PAPER 2

1. a) Two reagents that can be used to prepare chlorine gas are manganese (IV) oxide and concentrated hydrochloric acid.

i) Write an equation for the reaction. (1 mk)

ii) Give the formula of another reagent that can be reacted with concentrated hydrochloric acid to produce chlorine gas.

(1 mk)

iii) Describe how the chlorine gas could be dried in the laboratory (2mks)

b) In an experiment, dry chlorine gas was reacted with aluminium as shown

in

figure 1.

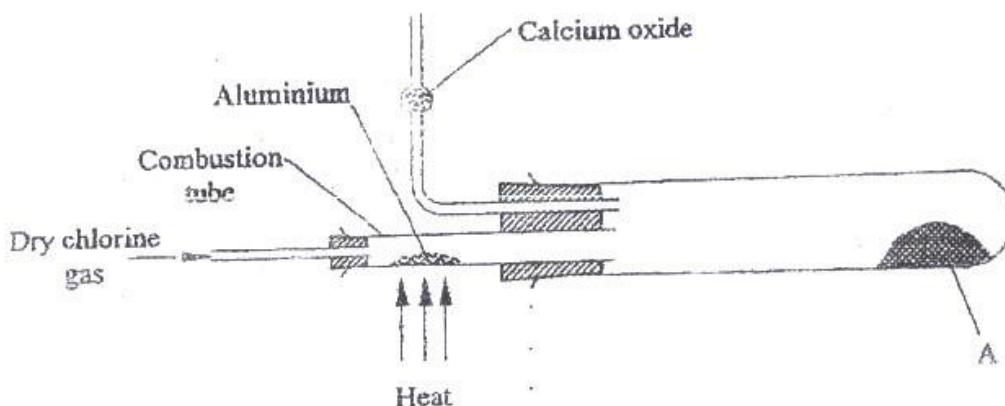

i) Name substance A. (1 mk)

ii) Write an equation for the reaction that took place in the combustion tube.

(1mk)

iii) 0.84 g of aluminium reacted completely with chlorine gas. Calculate the volume of chlorine gas used (Molar gas volume is 24dm^3 , $A_r = 27$).

(3

mks)

iv) Give two reasons why calcium oxide is used in the set up.

(2 mks)

2 a) Draw the structures of the following compounds: (2 mks)

i) 2-methylbut-2-ene;

ii) heptanoic acid

b) Describe a physical test that can be used to distinguish between methanol and hexanol. (2

mks)

c) Use the flow chart below to answer the questions that follow.

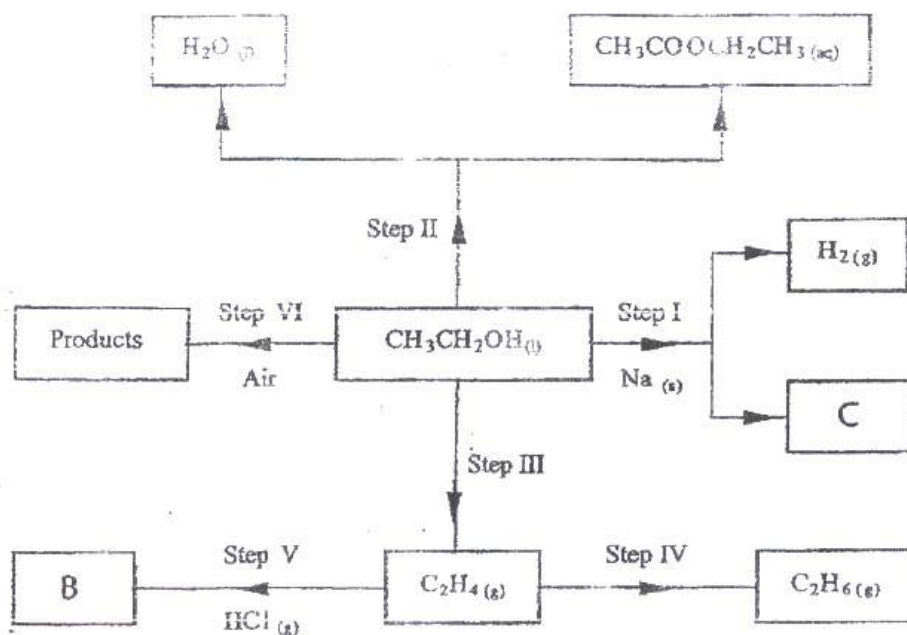

i) Name:

(I) the type of reaction that occurs in step II; (1 mk)

(II) Substance B. (1 mk)

ii) Give the formula of substance C. (1 mk)

iii) Give the reagent and the conditions necessary for the reaction in

step (IV)

(3mks)

3 The set-up below (figure 2) was used to electrolyse a bromide of metal D $D\text{Br}_2$.

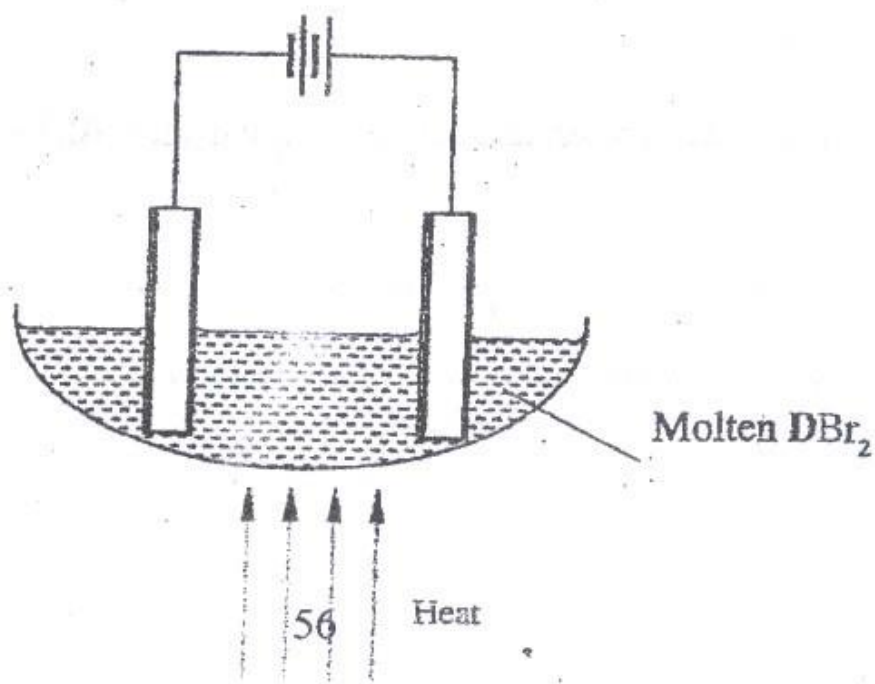

i) Write equation for the reactions at the

I cathode (1 mk)

II anode (1mk)

ii) The electrodes used in the experiment were made of carbon and metal D.
which of the two electrodes was used as the anode? Give a reason. (2 mks)

iii) Give a reason why this experiment is carried out in a fume cupboard. (1 mk)

iv) When a current of 0.4 A was passed for 90 minutes, 2.31 g of metal D were deposited.

I Describe how the amount of metal D deposited was determined.

(3 mks)

II Calculate the relative atomic mass of metal D. (1 Faraday = 96500 coulombs) (3 mks)

4. a) the schematic diagram shows part of the Solvay process used for the manufacture of sodium carbonate.

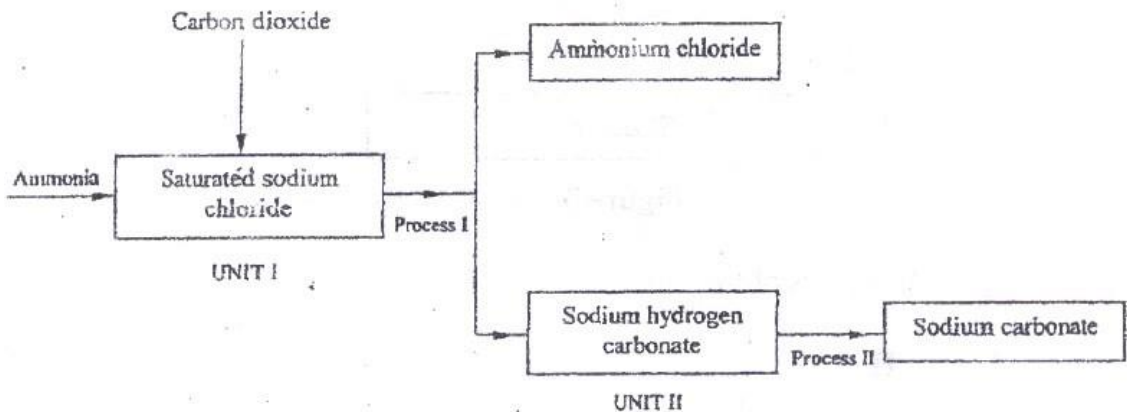

i) Explain how the sodium chloride required for this process is obtained

from sea water. (2

mks)

ii) Two main reactions take place in UNIT I. The first one is the formation of ammonium hydrogen carbonate.

I. Write an equation for this reaction (1 mk)

II. Write an equation for the second reaction (1 mk)

iii) State how the following are carried out: (2 mks)

I Process I

II) Process II

iv) In an experiment to determine the percentage purity of the sample of sodium carbonate produced in the Solvay process, 2.15 g of the sample reacted completely with 40.0 cm³ of 0.5 M sulphuric acid.

I calculate the number of moles of sodium carbonate that reacted. (2 mks)

II Determine the percentage of sodium carbonate in the

sample.

(Na = 23.0, C = 12.0, O = 16.0) (2 mks)

b) Name two industrial uses of sodium carbonate (2 mks)

have been identified and others labelled.

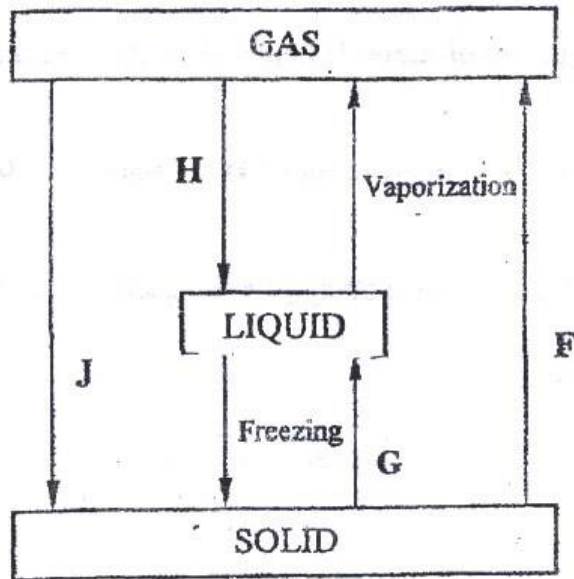

Figure 3

i) Give the

names of the processes

I H (1 mk)

II G (1 mk)

ii) Name one substance that can undergo process F when left in an open

container in the laboratory. (1 mk)

iii) The process J is called deposition. Using water as an example, write an equation that represents the process of deposition. (1 mk)

b) Figure 4 shows the heating curve for water.

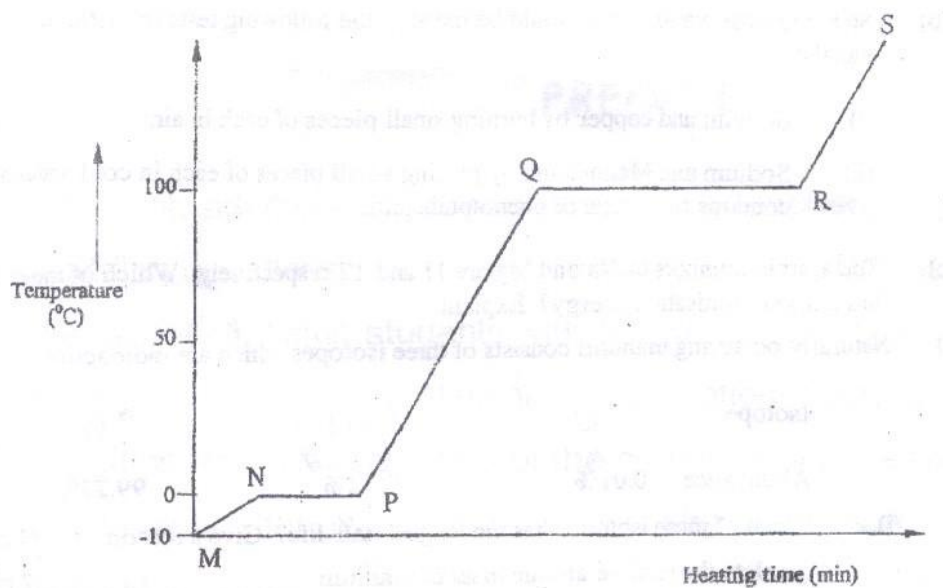

i) Give the names of the intermolecular forces of attraction in the segments;

- | | | |
|----|----|--------|
| I | MN | (1mk) |
| II | RS | (1 mk) |

ii) The heats of fusion and vaporization of water are 334.4 Jg^{-1} and 1159.4 Jg^{-1} respectively.

I Explain why there is a big difference between the two.(2mks)

II How is the difference reflected in the curve?
(1 mk)

c) Coal, oil and natural gas are major sources of energy. They are known as fossil fuels. Hydrogen is also a source of energy.

i) State and explain two reasons why hydrogen is a very attractive fuel

compared to fossils. (3

mks)

ii) State one disadvantage of using hydrogen fuel instead of fossil fuels.

6. a) Study the table below and complete it. (W^{-1} and X^{4+} are not the actual symbols of the ions).

(2

mks)

Iron	Number of protons	Number of neutrons	Mass Number	Electron arrangement
W	20	2.8.8
X^{4+}	14	28

b) State the observation that would be made in the following tests to distinguish between:

i) Sodium and copper burning pieces of each in air. (2 mks)

ii) Sodium and Magnesium by placing small pieces of each in cold

water which contains two drops of phenolphalein. (2mks)

c) The atomic numbers of Na and Mg are 11 and 12 respectively.

Which

of the elements has a higher ionization energy? Explain. (2mks)

d) Naturally occurring uranium consists of three isotopes which are radioactive.

Isotope	234	235	238
	U	U	U
Abundance	0.01%	0.72%	99.27%

i) Which of these isotopes has the longest half-life?

Give a reason

(1 mk)

ii) Calculate the relative atomic mass of uranium (2mks)

iii) $^{235}_{92}\text{U}$ is alpha emitter. If the product of the decay of this

U

$^{235}_{92}\text{U}$ nuclide is thorium (Th) . Write a nuclear equation for the

process.

(1mk)

7. Iron is obtained from haematite using a blast furnace shown in figure 5 below.

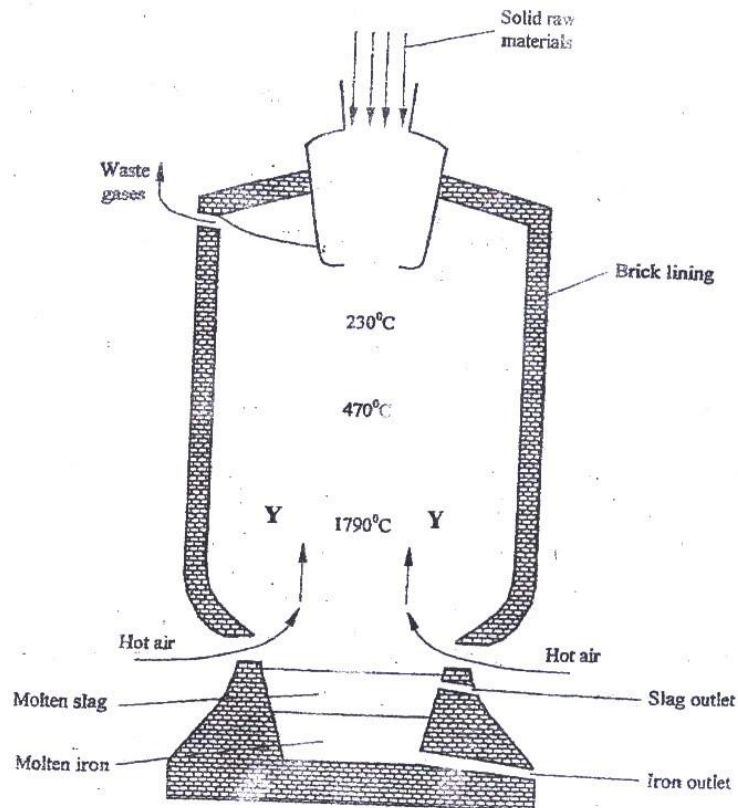

a) Four raw materials are required for the production of iron. Three of these are

iron oxide, hot air and limestone

Give the name of the fourth raw material

(1 mk)

b) Write an equation for the reaction in which carbon (IV) oxide is converted into carbon (II) oxide. (1mk)

c) Explain why the temperature in the region marked Y is higher than that of the incoming hot air. (2 mks)

d) State one physical property of molten slag other than density that allows it to be separated from molten iron as shown in figure 5. (1mk)

e) One of the components of the waste gases is Nitrogen (IV) oxide describe the adverse effects it has on the environment. (2mks)

f) Iron from the blast furnace contains about 5% carbon

- i) Describe how the carbon content is reduced. (2mks)
- ii) Why is it necessary to reduce the carbon content? (1 mk)