

MATHEMATICS PAPER 1 K.C.S.E 1995 QUESTIONS

SECTION 1 (52 MARKS)

Answer all the questions in this section

1. Without using logarithms tables evaluate (3 marks)

$$\sqrt{\frac{384.16 \times 0.0625}{96.04}}$$

2. Simplify (3 marks)

$$\frac{2x - 2}{6x^2 - x - 12} \div \frac{x - 1}{2x - 3}$$

3. Every week the number of absentees in a school was recorded. This was done for 39 weeks these observations were tabulated as shown below

Number of absentees	0.3	4 -7	8 -11	12 - 15	16 - 19	20 - 23
(Number of weeks)	6	9	8	11	3	2

Estimate the median absentee rate per week in the school (2 marks)

4. Manyatta village is 74 km North West of Nyangata village. Chamwe village is 42 km west of Nyangate. By using an appropriate scale drawing, find the bearing of Chamwe from Manyatta (2 marks)

5. A perpendicular to the line $-4x + 3 = 0$ passes through the point (8, 5) Determine its equation (2 marks)

6. The volume $V\text{cm}^3$ of an object is given by

$$V = \frac{2}{3} \pi r^3 \left(\frac{1 - 2}{s^2} \right)$$

Express in term of $\pi r, s$ and V (3 marks)

8. Two baskets A and B each contains a mixture of oranges and lemons. Basket A contains 26 oranges and 13 lemons. Basket B contains 18 oranges and 15 lemons. A child selected basket at random and picked at random a fruit from it. Determine the probability that the fruit picked was an orange.

9. A solid cone of height 12cm and radius 9 cm is recast into a solid sphere. Calculate the surface area of the sphere. (4 marks)

10. The first, the third and the seventh terms of an increasing arithmetic progression are three consecutive terms of a geometric progression. In the first term of the arithmetic progression is 10 find the common difference of the arithmetic progression. (4 marks)
11. Akinyi bought maize and beans from a wholesaler. She then mixed the maize and beans in the ratio 4:3 she bought the maize at Kshs. 12 per kg and the beans at 4 per kg. If she was to make a profit of 30% what should be the selling price of 1 kg of the mixture? (4 marks)
12. A clothes dealer sold 3 shirts and 2 trousers for Kshs. 840 and 4 shirts and 5 trousers for Kshs 1680.
Form a matrix equation to represent the above information. Hence find the cost of 1 shirt and the cost of 1 trouser. (4 marks)
13. Water flows from a tap. At the rate 27cm^3 per second, into a rectangular container of length 60cm, breadth 30 cm and height 40 cm. If at 6.00 p.m. the container was half full, what will be the height of water at 6.04 pm? (3 marks)
14. In the diagram below $\angle CAD = 20^\circ$, $\angle AFE = 120^\circ$ and BCDF is a cyclic quadrilateral. Find $\angle FED$. (3 marks)

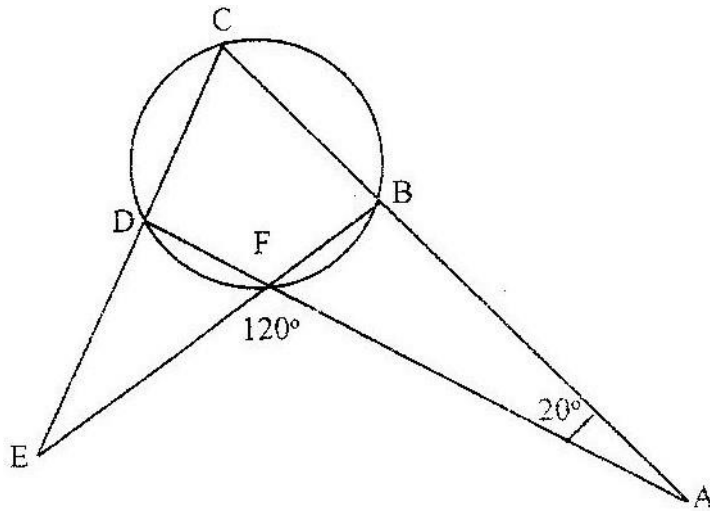

15. The cash price of a television is Kshs 25000. A customer paid a deposit of Kshs 3750. He repaid the amount owing in 24 equal monthly installments. If he was charged simple interest at the rate of 40% p.a, how much was each installment? (4 marks)
16. A bus takes 195 minutes to travel a distance of $(2x + 30)$ km at an average speed of $(x - 20)$ km/h.
Calculate the actual distance traveled. Give your answers in kilometers. (3 marks)

SECTION II (48 MARKS)

Answer any six questions from this section

17. At the beginning of every year, a man deposited Kshs 10,000 in a financial institution which paid compound interest at the rate of 20% p.a. He stopped further deposits after three years. The Money remained invested in the financial institution for a further eight years.

- (a) How much money did he have at the end of the first three years (4 marks) (b) How much interest did the money generate in the entire period (4 marks)

18. The figure below is a right pyramid with a rectangular base ABCD and VO as the height. The vectors $AD = a$, $AB = b$ and $DV = v$

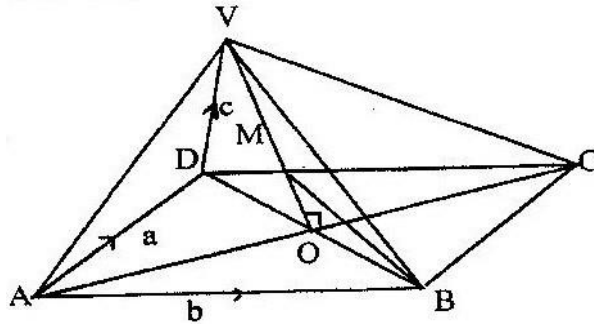

- (a) Express
- (i) AV in terms of a and c (1 mark)
 - (ii) BV in terms of a , b and c (2 marks)
- (b) M is point on OV such that $OM: MV = 3:4$, Express BM in terms of a , b and c .
Simplify your answer as far as possible (5 marks)

19. (a) In the figure below O is the centre of a circle whose radius is 5 cm $AB = 8$ cm and $\angle AOB$ is obtuse.

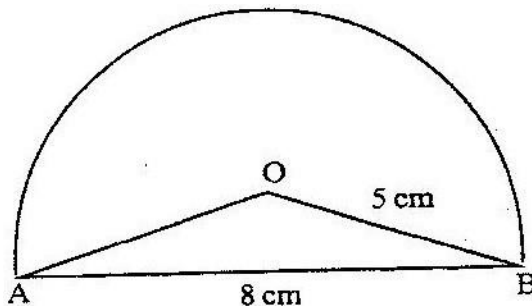

- Calculate the area of the major segment (6 marks)
- (b) A wheel rotates at 300 revolutions per minute. Calculate the angle in radians through which a point on the wheel turns in one second.

20. The table shows the height metres of an object thrown vertically upwards varies with the time t seconds

The relationship between s and t is represented by the equations $s = at^2 + bt + 10$ where b are constants.

t	0	1	2	3	4	5	6	7	8	9	10
s		45.1									

- (a) (i) Using the information in the table, determine the values of a and b (2 marks)
- (ii) Complete the table (1 mark)
- (b) (i) Draw a graph to represent the relationship between s and t (3 marks)
- (ii) Using the graph determine the velocity of the object when $t = 5$ seconds (2 marks)

21. (a) Construct a table of values for the function $y = x^2 - 6$ for $-3 < x < 4$ (2 marks)

- (b) By drawing a suitable line on the same grid estimate the roots of the equation $x^2 + 2x - 2 = 0$ (3 marks)

22. The figure below represents a plot of land ABCD, where $BC = CD = 60$ metres, $\angle BCD = 120^\circ$, $\angle ABC = 75^\circ$ and $\angle ADC = 85^\circ$

- (a) Calculate the distance from B to through D (5 marks)
- (b) The plot is to be fenced using poles that are 3 metres apart except at corner A, where the two poles next to the corner pole are each less than 3 metres from A. Calculate the distance from the pole at corner A to each of the poles next to it.

23. On the grid provided on the opposite page ABCE is a trapezium

- (a) ABCD is mapped onto A'B'C'D' by a positive quarter turn. Draw the image A'B'C'D' on the grid. (1 mark)

(b) A transformation maps $\begin{pmatrix} -2 & -1 \\ 1 & -1 \end{pmatrix} A'B'C'D$ onto $A''B''C''D''$

(i) Obtain the coordinates of $A''B''C''D''$ on the grid (2 marks)

(ii) Plot the image $A''B''C''D''$ on the grid (1mark)

(c) Determine a single matrix that maps $A''B''C''D''$ (4 marks)

MATHEMATICS PAPER 2 K.C.S.E 1995 QUESTIONS

SECTION 1 (52 MARKS)

1. Use logarithms to evaluate $\frac{(0.07284)^2}{\sqrt[3]{0.06195}}$ (4 marks)

$$\frac{(0.07284)^2}{\sqrt[3]{0.06195}}$$

2. Solve the simultaneous equations (4 marks)

$$\begin{aligned} 2x - y &= 3 \\ X^2 - xy &= -4 \end{aligned}$$

3. The tables shows the yearly percentage taxations rates.

Year	1987	1988	1989	1990	1991	1992	1993	1994
Percentage taxation rate	65	50	50	45	45	45	40	40

Calculate three- yearly moving averages for the data giving answers to s.f (3 marks)

4. Calculate volume of a prism whose length is 25cm and whose cross- section is an equilateral triangles of 3 cm

5. Find the value of x in the following equations:

$$49^{x+1} + 7^{2x} = 350 \quad (4 \text{ marks})$$

6. A translation maps a point (1, 2) onto (-2, 2). What would be the coordinates of the object whose image is (-3, -) under the same translation?

7. The ratio of the lengths of the corresponding sides of two similar rectangular water tanks is 3:5. The volume of the smaller tank is 8.1 m³. Calculate the volume of the larger tank. (3 marks)

8. Simplify completely

$$\frac{3x^2 - 1}{x^2 - 1} - \frac{2x + 1}{x + 1}$$

9. A boat moves 27 km/h in still water. It is to move from point A to a point B which is directly east of A. If the river flows from south to North at 9 km/h, calculate the track of the boat.

10. The second and fifth terms of a geometric progression are 16 and 2 respectively. Determine the common ratio and the first term

11. In the figure below $CP = CQ$ and $\angle CQP = 160^\circ$. If ABCD is a cyclic quadrilateral, find $\angle BAD$.

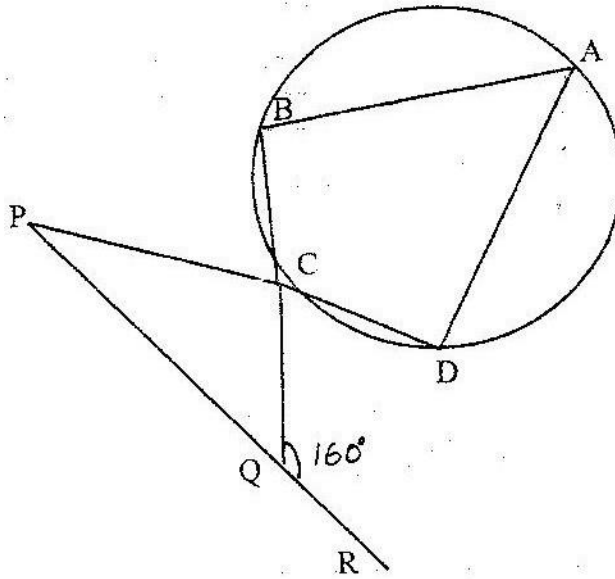

12. In the figure below, $OA = 3i + 3j$, $OB = 8i - j$, C is a point on AB such that $AC : CB = 3 : 2$, and D is a point such that $OB \parallel CD$ and $2OB = CD$.

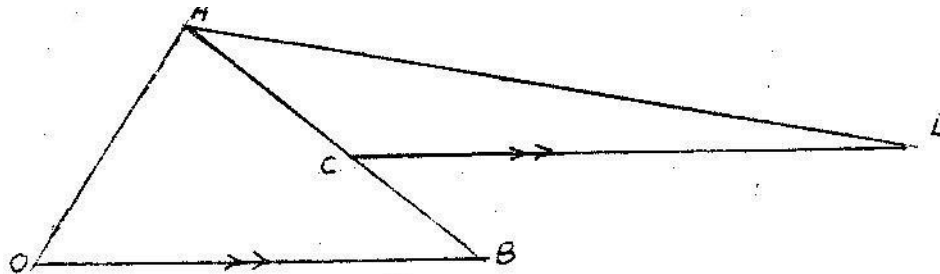

Determine the vector DA in terms of i and j.

(4 marks)

13. Without using logarithm tables, find the value of x in the equation

$$\text{Log } x^3 + \log 5x = 5 \log 2 - \log \frac{2}{5} \quad (3 \text{ marks})$$

14. Two containers, one cylindrical and one spherical, have the same volume. The height of the cylindrical container is 50 cm and its radius is 11 cm. Find the radius of the spherical container. (2 marks)
15. Two variables P and L are such that P varies partly as L and partly as the square root of L. Determine the relationship between P and L when L = 16, P = 500 and when L = 25, P = 800. (5 marks)
16. The shaded region below represents a forest. The region has been drawn to scale where 1 cm represents 5 km. Use the mid – ordinate rule with six strips to estimate the area of forest in hectares. (4 marks)

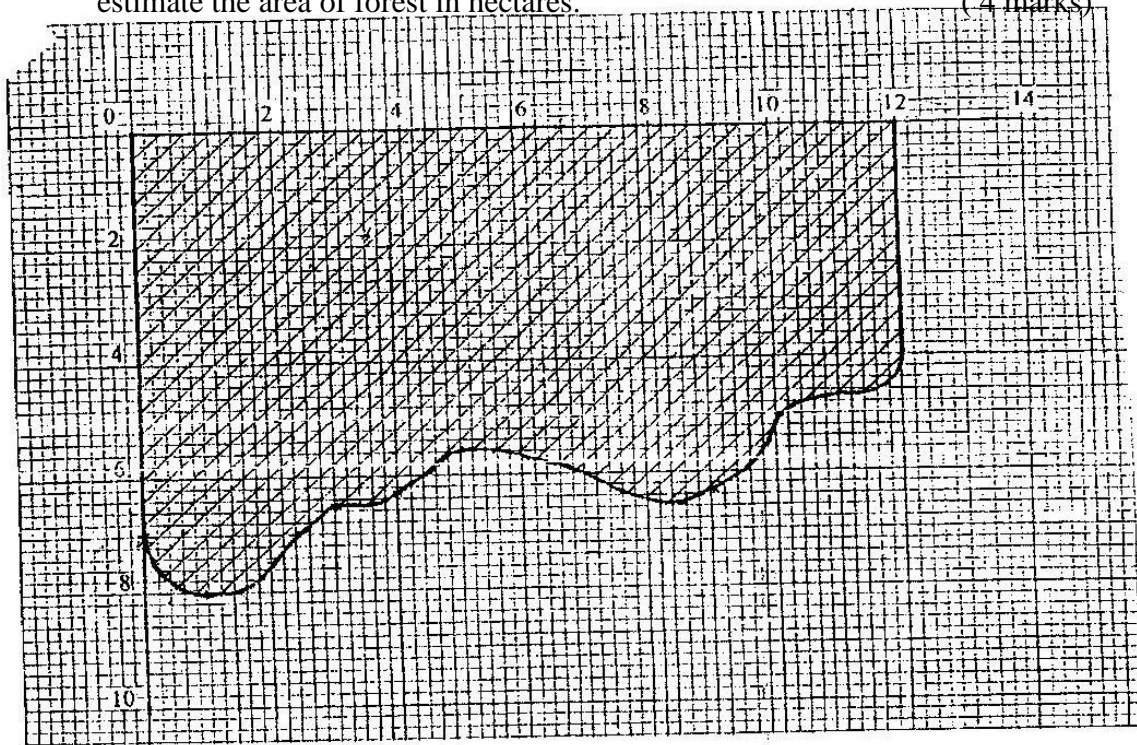

SECTION II (48 Marks)

Answer any six questions from this section

17. A circular path of width 14 metres surrounds a field of diameter 70 metres. The path is to be carpeted and the field is to have a concrete slab with an exception of four rectangular holes each measuring 4 metres by 3 metres. A contractor estimated the cost of carpeting the path at Kshs. 300 per square metre and the cost of putting the concrete slab at Kshs 400 per square metre. He

then made a quotation which was 15% more than the total estimate. After completing the job, he realized that 20% of the quotation was not spent.

- (a) How much money was not spent?
- (b) What was the actual cost of the contract?

18. The table below shows high altitude wind speeds recorded at a weather station in a period of 100 days.

Wind speed (knots)	0 - 19	20 - 39	40 - 59	60-79	80- 99	100- 119	120-139	140-159	160-179
Frequency (days)	9	19	22	18	13	11	5	2	1

(a) On the grid provided draw a cumulative frequency graph for the data (4 marks)

(b) Use the graph to estimate

- (i) The interquartile range (3 marks)
- (ii) The number of days when the wind speed exceeded 125 knots (1 mark)

19. The probabilities that a husband and wife will be alive 25 years from now are 0.7 and 0.9 respectively.

Find the probability that in 25 years time,

- (a) Both will be alive
- (b) Neither will be alive
- (c) One will be alive
- (d) At least one will be alive

20. A hillside is in the form of a plane inclined at an angle of 30° to the horizontal. A straight section of road 800 metres long lies along the line of greatest slope from a point A to a point B further up the hillside.

- (a) If a vehicle moves from A and B, what vertical height does it rise?
- (b) D is another point on the hillside and is on the same height as B. Another height straight road joins and D and makes an angle of 60° with AB. C is a point on AD such that $AC = \frac{3}{4} AD$.

Calculate

- (i) The length of the road from A to C
- (ii) The distance of CB
- (iii) The angle elevation of B and C

21. A part B is on a bearing of 080° from a port A and at a distance of 95 km. A submarine is stationed at a port D, which is on a bearing of 200° from AM and a distance of 124 km from B.

A ship leaves B and moves directly southwards to an island P, which is on a bearing of 140 from A. The submarine at D on realizing that the ship was heading for the island P, decides to head straight for the island to intercept the ship

Using a scale of 1 cm to represent 10 km, make a scale drawing showing the relative positions of A, B, D, P. (2 marks)

Hence find

(i) The distance from A to D (2 marks)

(ii) The bearing of the submarine from the ship was setting off from B (1 mark)

(iii) The bearing of the island P from D (1 mark)

(iv) The distance the submarine had to cover to reach the island P (2 marks)

22. Using ruler and compasses only, construct a parallelogram ABCD such that $AB = 10\text{cm}$, $BC = 7\text{cm}$ and $\angle ABC = 105^\circ$. Also construct the loci of P and Q within the parallelogram such that $AP \leq 4\text{ cm}$, and $BC \leq 6\text{ cm}$. Calculate the area within the parallelogram and outside the regions bounded by the loci.

23. (a) Complete the table for the function $y = 2 \sin x$ (2 marks)

x	0°	10°	20°	30°	40°	50°	60°	70°	80°	90°	100°	110°	120°
Sin 3x	0	0.5000											
y	0	1.00											

(b) (i) Using the values in the completed table, draw the graph of $y = 2 \sin 3x$ for $0^\circ \leq x \leq 120^\circ$ on the grid provided

(ii) Hence solve the equation $2 \sin 3x = -1.5$ (3 marks)

24. A manufacture of jam has 720 kg of strawberry syrup and 800 kg of mango syrup for making two types of jam, grade A and B. Each types is made by mixing strawberry and mango syrups as follows:

Grade A: 60% strawberry and 40% mango

Grade B: 30% strawberry and 70% mango

The jam is sold in 400 gram jars. The selling prices are as follows:

Grade A: Kshs. 48 per jar

Grade B: Kshs 30 per jar.

(a) Form inequalities to represent the given information (3 marks)

(b) (i) On the grid provided draw the inequalities (3 marks)

(ii) From your, graph, determine the number of jars of each grade the manufacturer should produce to maximize his profit (1 mark)

- (iii) Calculate the total amount of money realized if all the jars are sold
(1 mark)

MATHEMATICS PAPER 1 K.C.S.E 1996 QUESTIONS
SECTION 1 (52 Marks)

1. Use logarithms to evaluate (3 marks)

$$\sqrt[3]{\frac{36.15 \times 0.02573}{1,938}}$$

2. Factorize completely $3x^2 - 2xy - y^2$ (2 marks)
3. The cost of 5 skirts and 3 blouses is Kshs 1750. Mueni bought three of the skirts and one of the blouses for Kshs 850.
Find the cost of each item (3 marks)
4. A man walks directly from point A towards the foot of a tall building 240m away. After covering 180m, he observes that the angle of the top of the building is 45°. Determine the angle of elevation of the top of the building from A. (3 marks)
5. In the figure below, ABCD is a cyclic quadrilateral and BD is a diagonal. EADF is a straight line. $\angle CDF = 68^\circ$, $\angle BDC = 45^\circ$ and $\angle BAE = 98^\circ$.

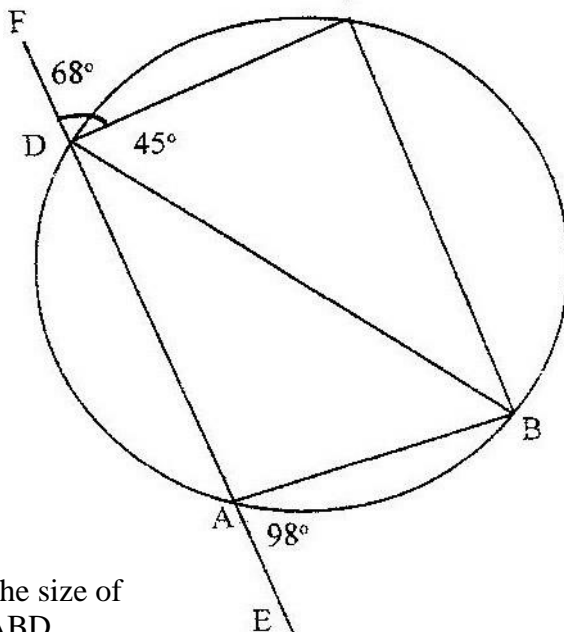

Calculate the size of

- (a) $\angle ABD$ (2 marks)
- (b) $\angle CBD$ (2 marks)
6. An employee started on a salary of £ 6,000 per annum and received a constant annual increment. If he earned a total of £ 32,400 by the end of five years,

calculate his annual increment. (3 marks)

7. Mr. Ngeny borrowed Kshs. 560,000 from a bank to buy a piece of land. He was required to repay the loan with simple interest for a period of 48 months. The repayment amounted to Kshs 21000 per month.

Calculate

- (a) The interest paid to the bank (2 marks)
(b) The rate per annum of the simple interest (4 marks)

8. A rectangular tank of base 2.4 m by 2.8 m and a height of 3 m contains 3,600 liters of water initially. Water flows into the tank at the rate of 0.5 litres per second

Calculate the time in hours and minutes, required to fill the tank (4 marks)

9. A car dealer charges 5% commission for selling a car. He received a commission of Kshs 17,500 for selling a car. How much money did the owner receive from the sale of his car? (2 marks)

10. Five pupils A, B, C, D and E obtained the marks 53, 41, 60, 80 and 56 respectively. The table below shows part of the work to find the standard deviation.

Pupil	Mark x	x - x	(x-x) ²
A	53	-5	
B	41	-17	
C	60	2	
D	80	22	
E	56	-2	

- (a) Complete the table (1 mark)

- (b) Find the standard deviation (3 marks)

11. A and B are two matrices. If $A = \begin{pmatrix} 1 & 2 \\ 4 & 3 \end{pmatrix}$ find B given that $A^2 = A + B$ (4 marks)

12. Solve the equation

$$\sin \frac{5}{2} \theta = \frac{-1}{2} \text{ for } 0^\circ \leq \theta \leq 180^\circ \quad (2 \text{ marks})$$

13. A fruiterer bought 144 pineapples at Kshs 100 for every six pineapples. She sold some of them at Kshs. 72 for every three and the rest at Kshs 60 for every two. If she made a 65% profit, calculate the number of pineapples sold at Kshs 72 for every three (3 marks)

14. Make V the subject of the formula

$$T = \frac{1}{2} m (u^2 - v^2)$$

(3 marks)

15. The figure below represents a hollow cylinder. The internal and external radii are estimated to be 6 cm and 8 cm respectively, to the nearest whole number. The height of the cylinder is exactly 14 cm.

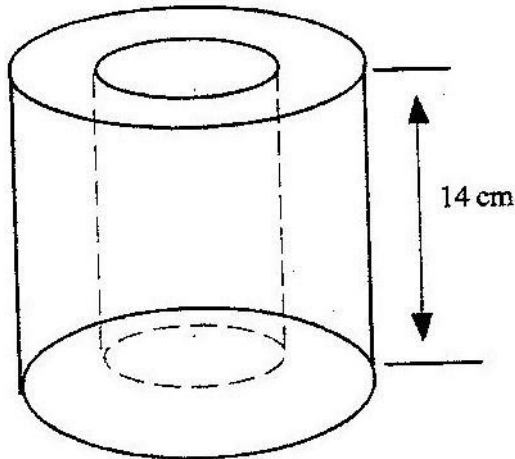

- (a) Determine the exact values for internal and external radii which will give maximum volume of the material used. (1 mark)
- (b) Calculate the maximum possible volume of the material used
Take the value of π to be $22/7$ (2 marks)
16. Two lorries A and B ferry goods between two towns which are 3120 km apart. Lorry A traveled at x km/h faster than lorry B and B takes 4 hours more than lorry A to cover the distance.

Calculate the speed of lorry B (5 marks)

SECTION II (48 MARKS)

Answer any six questions from this section

17. The data given below represents the average monthly expenditure, E in K £, on food in a certain village. The expenditure varies with number of dependants, D in the family.

Dependants	3	7	12	25	32
Expenditure E (K£)	-210	250	305	440	500

- (a) Using the grid provided, plot E against D and draw the line of the best fit (2 marks)

- (b) Find the gradient and the E- intercept of the graph (3 marks)
- (c) Write down an equation connecting E and D (1 mark)
- (d) Estimate the cost of feeding a family with 9 dependants (2 marks)

18. The table below shows the income tax rates

Total income per month in Kenya	Rate in shillings per pound
1 – 325	2
326 – 650	3
651-975	4
976 – 1300	5
1301 – 1625	7
Over 1625	7.50

Mr. Otiende earned a basic salary of Kshs 13,120 and a house allowance of Kshs 3,000 per month. He claimed a tax relief for a married person of Kshs 455 per month

- (a) Calculate
 - (i) The tax payable without the relief
 - (ii) The tax paid after the relief
- (b) Apart from the income tax, the following monthly deductions are made. A service charge of Kshs 100, a health insurance fund of Kshs 280 and 2% of his basic salary as widow and children pension scheme.

Calculate

- (i) The total monthly deductions made from Mr. Otiende's income (2 marks)
- (ii) Mr. Otiende's net income from his employment (2 marks)

19. The equation of a curve is $y = 3x^2 - 4x + 1$

- (a) Find the gradient function of the curve and its value when $x = 2$ (2 marks)
- (b) Determine
 - (i) The equation of the tangent to the curve at the point (2, 5) (2 marks)
 - (ii) The angle which the tangent to the curves at the point (2, 5) makes with the horizontal (1 mark)
 - (iii) The equation of the line through the point (2, 5) which is perpendicular to the tangent in (b) (i)

20. The position of two A and B on the earth's surface are (36° N, 49° E) and (36° N, 131° W) respectively.

- (a) Find the difference in longitude between town A and town B (2 marks)
- (b) Given that the radius of the earth is 6370, calculate the distance between town A and town B.
- (c) Another town, C is 840 east of town B and on the same latitude as towns A and B. Find the longitude of town C.

21. The table below shows some values of the function $y = x^2 + 2x - 3$

x	-6	-6.75	-5.5	-5	-4.75	-4.5	4.25	-4.0	-3.75	-3.75	-3.5	-3.25	-3
y	21	18.56		14.06		10.06	8.25		5		2.25	1.06	0

- a) Complete the table
- b) Using the completed table and the mid-ordinate rule with six ordinates, estimate the area of the region bounded by the $y = x^2 + 2x - 3$ and the line $y = 0$, $x = -6$ and $x = -3$ (3 marks)
- (i) By integration find the actual area of the region in (b) above (2 marks)
- (ii) Calculate the percentage error arising from the estimate in (b) (2 marks)
22. In the diagram below OABC is a parallelogram, $OA = a$ and $AB = b$. N is a point on OA such that $ON:NA = 1:2$

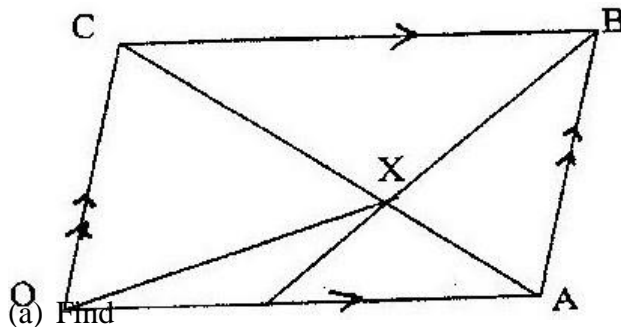

- (a) Find
- (i) AC in terms of a and b
- (ii) BN in terms of a and b
- (b) The lines AC and BN intersect at X , $AX = hAC$ and $BX = kBN$
- (i) By expressing OX in two ways, find the values of h and k
- (ii) Express OX in terms of a and b (1 mark)

23. Use ruler and compasses only in this question The diagram below shows three points A, B and D

(a) Construct the angle bisector of acute angle BAD (1 mark)

(b) A point P, on the same side of AB and D, moves in such a way that $\angle APB = 22\frac{1}{2}^\circ$ construct the locus of P (6 marks)

(c) The locus of P meets the angle bisector of $\angle BAD$ at C measure $\angle ABC$ (1 mark)

Hence find area of the image A'' B'' C'' (2 marks)

SECTION II (48 Marks)

Answer any six questions from this section

17. Two businessmen jointly bought a minibus which could ferry 25 paying passengers when full. The fare between two towns A and B was Kshs 80 per passengers for one way. The minibus made three round trips between two towns daily. The cost of fuel was Kshs 1500 per day. The driver and the conductor were paid daily allowances of 200 and Kshs 150 respectively.

A further Kshs 4,000 per day was set aside for maintenance, insurance and loan payment.

(a) One day, the minibus was full on every trip.

(i) How much money was collected from the passengers that day?

(ii) How much was the net profit?

(b) On another day, the minibus was 80% full on the average for the three round trips, how much and each businessman get if the day's profit was shared in the ratio of 2: 3

18. In the figure below AOC is a diameter of the circle centre O; $AB = BC$ and \angle

$\angle ACD = 25^\circ$, EBF is a tangent to the circle at B . G is a point on the minor arc CD .

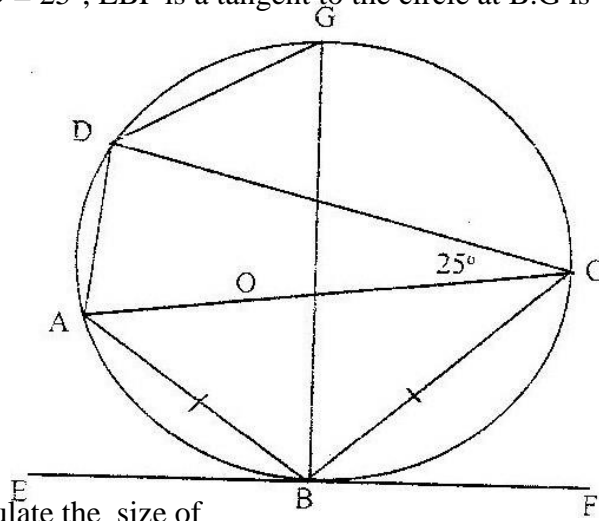

- (a) Calculate the size of
- (i) $\angle BAD$ (3 marks)
 - (ii) the Obtuse $\angle BOD$ (3 marks)
 - (iii) $\angle BGD$ (1 mark)
- (b) Show the $\angle ABE = \angle CBF$. Give reasons (2 marks)

19. In an agricultural research centre, the length of a sample of 50 maize cobs were measured and recorded as shown in the frequency distribution table below.

Length in cm	Number of cobs
8 – 10	4
11 – 13	7
14 – 16	11
17 – 19	15
20 – 22	8
23 - 25	5

Calculate

- (a) The mean
 - (b) (i) the variance
 - (ii) The standard deviation (8 marks)
20. Four towns R, T, K and G are such that T is 84 km directly to the north R, and K is on a bearing of 295° from R at a distance of 60 km. G is on a bearing of 340° from K and a distance of 30 km. Using a scale of 1 cm to represent 10 km, make an accurate scale drawing to show the relative positions of the town.

Find

- (a) The distance and the bearing of T from K
- (b) The distance and the bearing G from T
- (c) The bearing of R from G

21. Kubai saved Kshs 2,000 during the first year of employment. In each subsequent year, he saved 15% more than the preceding year until he retired.

- (a) How much did he save in the second year? (1 mark)
- (b) How much did he save in the third year? (1 mark)
- (c) Find the common ratio between the savings in two consecutive years
(3 marks)
- (d) How many years did he take to save the savings a sum of Kshs 58,000?
(3 marks)
- (e) How much had he saved after 20 years of service? (2 marks)

22. A school has to take 384 people for a tour. There are two types of buses available, type X and type Y. Type X can carry 64 passengers and type Y can carry 48 passengers. They have to use at least 7 buses.

- (a) Form all the linear equalities which will represent the above information
(3 marks)

(b) On the grid provided, draw the inequalities and shade the

Unwanted region (3 marks)

(c) the charges for hiring the buses are

Type X. Kshs 25000

Type y: Kshs 20000

Use your graph to determine the number of buses of each type that should be hired to minimize the cost.

23. Complete the table given below using the functions. $Y = -3 \cos 2x^0$ and $y = 2 \sin (\frac{3}{2} x^0 + 30^0)$ for $0 < x < 180^0$

X°	0°	20°	40°	60°	80°	100°	120°	140°	160°	180°
$-3 \cos 2x^{\circ}$	-3.00			1.50	2.82	2.82		0.52	-2.30	
$2 \sin (3/2 x^{\circ} + 30^{\circ})$	1.00		2.00	1.73		0.00	-1.00			-1.73

(a) Using the grid provided, draw the graphs $y = -3 \cos 2x^{\circ}$ and $y = 2 \sin (3/2 x^{\circ} + 30^{\circ})$ on the same axes.

Take 1 cm to represent 20° on the x - axis and 2 cm to represent one unit on the y - axis. (4 marks)

(b) From your graphs, find the roots of $3 \cos 2x + \sin (3/2 x^{\circ} + 30^{\circ}) = 0$

24. Data collected from an experiment involving two variables X and Y was recorded as shown in the table below

x	1.1	1.2	1.3	1.4	1.5	1.6
y	-0.3	0.5	1.4	2.5	3.8	5.2

The variables are known to satisfy a relation of the form $y = ax^3 + b$ where a and b are constants

(a) For each value of x in the table above, write down the value of x^3 (2 marks)

(b) (i) By drawing a suitable straight line graph, estimate the values of a and b

(2 marks)

(ii) Write down the relationship connecting y and x

MATHEMATICS PAPER 121/1 K.C.S.E 1997 QUESTIONS

SECTION 1 (52 marks)

Answer all the questions in this section

1. Use logarithms to evaluate $(1934)^2 \times 0.00324$

$$\sqrt{436}$$

2. Find the greatest common factor of x^3y^2 and $4xy^4$. Hence completely the expression $x^3y^2 - 4xy^4$

3. In the figure below PQRS is a rhombus, $\angle SQR = 55^{\circ}$, $\angle QST$ is a right angle and TPQ is a straight line

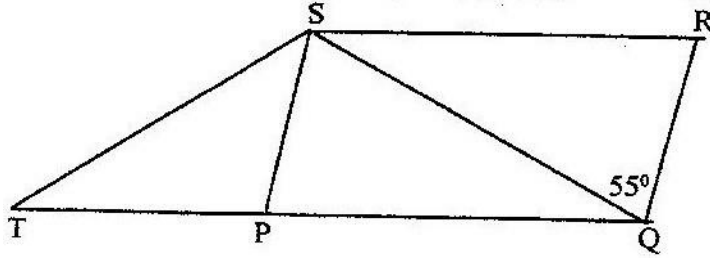

Find the size of the angle STQ

4. In geometric progression, the first is a and the common ratio is r . The sum of the first two terms is 12 and the third term is 16.
 - (a) Determine the ratio $\frac{ar^2}{a + ar}$
 - (b) If the first term is larger than the second term, find the value of r .

5. There are two signposts A and B on the edge of the road. A is 400 m to the west of B. A tree is on a bearing of 060° from A and a bearing of 330° from B. Calculate the shortest distance of the tree from the edge of the road.

6. A cylinder of radius 14 cm contains water. A metal solid cone of base radius 7 cm and height 18 cm is submerged into the water. Find the change in height of the water level in the cylinder.

7. A company saleslady sold worth Kshs 42,000 from this sale she earned a commission of Kshs 4,000
 - (a) calculate the rate of commission
 - (b) If she sold goods whose total marked price was Kshs 360,000 and allowed a discount of 2% calculate the amount of commission she received.

8. The following enrollment figures for twenty primary schools were collected

934	923	936	924	933	933	937	926	923
934	931	929	934	927	932	934	927	940

 - (a) Determine the mode
 - (b) The difference from an assumed mean were obtained and rearranged as follows
 - (i) Determine the assumed mean
 - (ii) Use the assumed mean in (b) (i) to find the mean enrolment

9. Given that $\left[\begin{matrix} A \\ 1 \end{matrix} \right] = 3 \left[\begin{matrix} B \\ 3 \end{matrix} \right] + 1$, $\left[\begin{matrix} C \\ p \end{matrix} \right] = 0$ and $AB = BC$, determine the value of P

$$5x^3 - 3x^2 - 2x + 1 = 0$$

10. The curve $y = ax^3 - 3x^2 - 2x + 1$ has the gradient 7 when $x=1$. Find the value of a
11. Find the value of θ between 0° and 360° satisfying the equation $5 \sin \theta = 4$
12. A businesswoman bought two bags of maize at the same price per bag. She discovered that one bag was of high quality and the other of low quality. On the high quality bag she made a profit by selling at Kshs 1,040. Whereas on the low quality bag she made a loss by selling at Kshs 880. If the profit was three times the loss, calculate the buying price per bag.
13. Given that $y = \frac{b - bx^2}{cx^2 - a}$ make x the subject
14. Two towns P and Q are 400 km apart. A bus left P for Q. It stopped at Q for one hour and then started the return journey to P. One hour after the departure of the bus from P, a trailer also heading for Q left P. The trailer met the returning bus $\frac{3}{4}$ of the way from P to Q. They met t hours after the departure of the bus from P.
- (a) Express the average speed of the trailer in terms of t
- (b) Find the ratio of the speed of the bus so that of the trailer.
15. Akinyi bought three cups and four spoons for Kshs. 324. Wanjiku bought five cups and Fatuma bought two spoons of the same type as those bought by Akinyi.
Wanjiku paid Kshs 228 more than Fatuma. Find the price of each cup and spoon.
16. (a) Work out the exact value of $R = \frac{1}{0.003146 - 0.003130}$
- (b) An approximate value of R may be obtained by first correcting each of the decimal in the denominator to 5 decimal places
- (i) The approximate value
- (ii) The error introduced by the approximation

SECTION II (48 MARKS)

Answer six questions from this section

17. The figure below shows a portable kennel

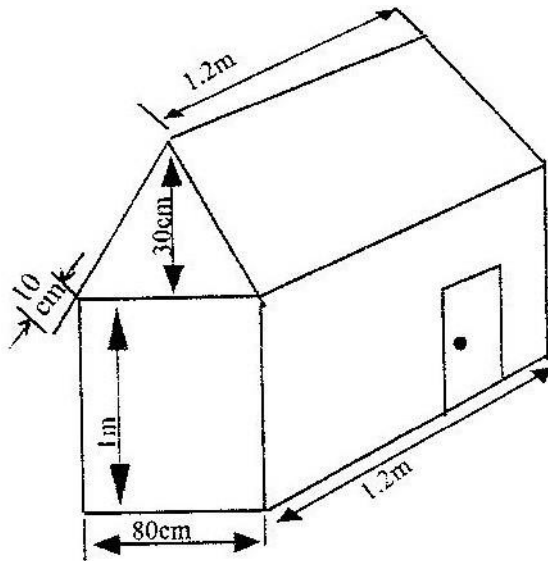

- (a) Calculate
- The total surface area of the walls and the roof (include the door as part of the wall)
 - The total area of the roof
- (b) The cost of roofing is Kshs 300 per square metre and that of making walls and floor Kshs 350 per square metre. Find the cost of making the kennel
- (c) Find the cost of roofing another kennel whose dimensions are 50% more than those of given kennel.

18. A ship leaves an island (5°N , 45°E) and sails due east for 120 hours to another island. The average speed of the ship is 27 knots.

- (a) Calculate the distance between the two islands
- in nautical miles
 - in kilometers
- (b) Calculate the speed of the ship in kilometers per hour
- (c) Find the position of the second island
(take 1 nautical mile to be 1.853 Km and the radius of the earth to be 6370 Km)

19. Using ruler and compasses only construct triangle ABC such that $AB = 4\text{ cm}$, $BC = 5\text{ cm}$ and $\angle ABC = 120^{\circ}$. Measure AC.

On the diagram, construct a circle which passes through the vertical of the triangle ABC.

Measure the radius of the circle

Measure the shortest distance from the centre of the circle to line BC.

20. (a) Draw the graph of $y = 6 + x - x^2$, taking integral value of x in $-4 \leq x \leq 5$. (The grid is provided. Using the same axes draw the graph of $y = 2 - 2x$)
- (b) From your graphs, find the values of X which satisfy the simultaneous equations $y = 6 + x - x^2$ $y = 2 - 2x$
- (c) Write down and simplify a quadratic equation which is satisfied by the values of x where the two graphs intersect.

21. The water supply in a town depends entirely on two water pumps. A and B. The probability of pump A failing is 0.1 and the probability of pump B failing is 0.2. Calculate the probability that

- (a) Both pumps are working
 (b) There is no water in the town
 (c) Only one pump is working
 (d) There is some water in the town

22. In the figure below $OA = a$, $OB = b$, $AB = BC$ and $OB : BD = 3 : 1$

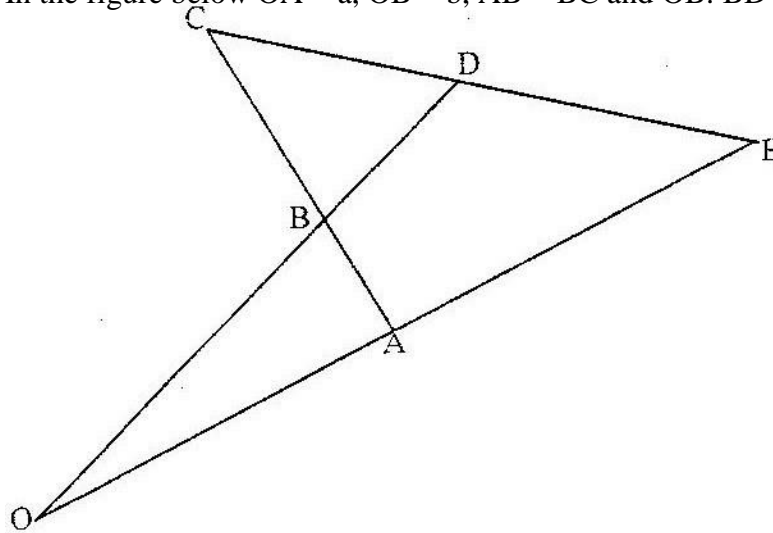

- (a) Determine
- (i) AB
 (ii) CD , in terms of a and b
- (b) If $CD : DE = 1 : k$ and $OA : AE = 1 : m$ determine
- (i) DE in terms of a , b and k
23. The figure on the grid shows a triangular shaped object ABC and it's image $A'B'C'$
- (a) (i) Describe fully the transformation that maps ABC and $A'B'C'$

(ii) Find a 2×2 matrix that transforms triangle ABC onto triangle A' B' C'

(b) The matrix $P = \begin{pmatrix} 2 & 1 \\ 1 & 1 \end{pmatrix}$ transforms triangle ABC onto A'' B'' C''

(i) Find the coordinates of A'' B'' C''

(c) Find the area of triangle ABC

(d) Hence find the area of the image A'' B'' C

24. The coordinates of the points P and Q are (1, -2) and (4, 10) respectively. A point T divides the line PQ in the ratio 2: 1

(a) Determine the coordinates of T

(b) (i) Find the gradient of a line perpendicular to PQ

(ii) Hence determine the equation of the line perpendicular PQ and passing through T

(iii) If the line meets the y- axis at R, calculate the distance TR, to three significant figures

MATHEMATICS PAPER 121/2 K.C.S.E 1997 QUESTIONS

SECTION 1 (52 Marks)

Answer all questions in this section

1. evaluate without using mathematical tables

$$\frac{1.9 \times 0.032}{20 \times 0.0038}$$

2. Mary has 21 coins whose total value is Kshs 72. There are twice as many five shillings coins as there are ten shillings coins. The rest are one shillings coin. Find the number of ten shillings coins that Mary has.
3. A commercial bank buys and sells Japanese yen in Kenya shillings at the rates shown below.

Buying	Selling
Kshs 0.5024	Kshs. 0.5446

A Japanese tourist at the end of his tour of Kenya was left with Kshs 30,000 which he converted to Japanese yen through the commercial bank. How many Japanese yen did he get?

4. On the figure below construct
- (i) the perpendicular bisector of BC
 - (ii) The locus of a point P which moves such a way that $\angle APB = \angle AVB$ and P is on the same side of AB as C

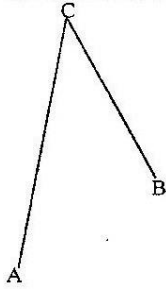

5. The figure below represents a circle a diameter 28 cm with a sector subtending an angle of 75° at the centre.

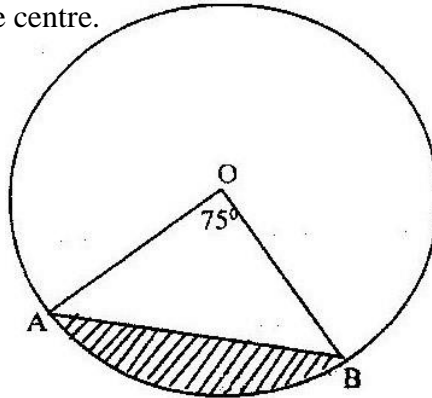

Find the area of the shaded segment to 4 significant figures

6. A pyramid of height 10cm stands on a square base ABCD of side 6 cm
- Draw a sketch of the pyramid
 - Calculate the perpendicular distance from the vertex to the side AB
7. Find the value of m in the following equation

$$\left(\frac{1}{2}\right)^m \times (81)^{-1} = 243$$

8. Use the
with
cm to
area of the
below

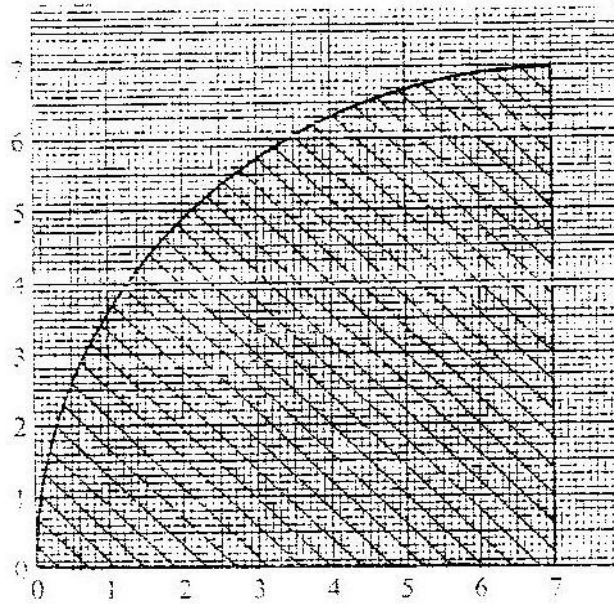

trapezoidal rule
intervals of 1
estimate the
shaded region

9. Expand and simplify $(1 - 3x)^5$, up to the term in x^3

Hence use your expansion to estimate $(0.97)^5$ correct to 4 decimal places

10. On the surface of a cuboid ABCDEFGH a continuous path BFDHB is drawn as shown by the arrows below

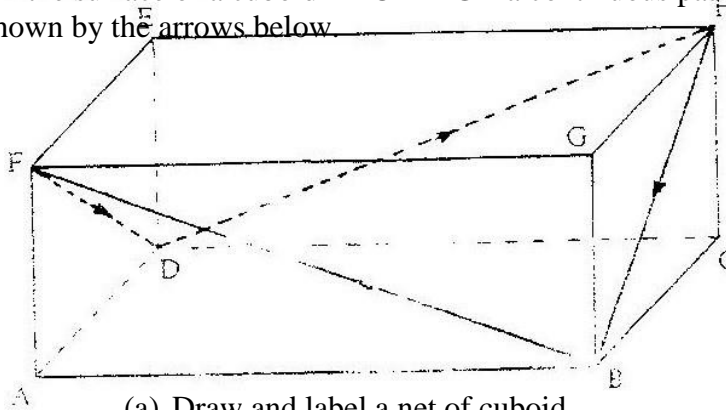

(a) Draw and label a net of cuboid

(b) On the net show the path

11. ABC is a triangle and P is on AB such that P divides AB internally in the ratio 4:3. Q is a point on AC such that PQ is parallel to BC. If AC = 14 cm

(i) State the ratio AQ:QC

(ii) Calculate the length of QC

12. $\sqrt{14} - \sqrt{14}$ $a\sqrt{7} + b\sqrt{2}$

$\sqrt{\quad} \sqrt{\quad}$ $\sqrt{\quad} \sqrt{\quad}$

$$\frac{\quad}{7 - 2} = \frac{\quad}{7 + 2}$$

Find the values of a and b where b are rational numbers

13. The table below represents the mean scores in six consecutive assessment tests given a form four class

Tests	T ₁	T ₂	T ₃	T ₄	T ₅	T ₆
Mean scores in percentage	48.40	56.25	50.30	49.00	45.60	57.65

Calculate the three moving averages of order 4

14. Mogaka and Onduso working together can do a piece of work in 6 days, Mogaka, working alone takes 5 days longer than Onduso. How many days does it take Onduso to do the work alone?
15. The athletes in an 800 metres race take 104 seconds and 108 seconds respectively to complete the race. Assuming each athlete is running at a constant speed. Calculate the distance between them when the faster athlete is at the finishing line.
16. A metal bar is a hexagonal prism whose length is 30 cm. The cross – section is a regular hexagon with each side of the length 6 cm.
Find
(i) the area of the hexagonal face
(ii) the volume of the metal bar

SECTION II (48 MARKS)

Answer any six questions from this section

17. A company is to construct a parking bay whose area is 135m^2 . It is to be covered with concrete slab of uniform thickness of 0.15. To make the slab cement, Ballast and sand are to be mixed so that their masses are in the ratio 1: 4: 4. The mass of m^3 of dry slab is 2, 500kg.
Calculate
(a) (i) The volume of the slab
(ii) The mass of the dry slab

(iii) The mass of cement to be used

- (b) If one bag of the cement is 50 kg, find the number of bags to be purchased
- (c) If a lorry carries 7 tonnes of sand, calculate the number of lorries of sand to be purchased

18. Complete the table below by filling in the blank spaces

x°	0°	30°	60°	90°	120°	150°	180°	210°	240°	270°	300°	330°	360°
$\cos x^{\circ}$	1.00	0.87	0.50	0	-0.5	-0.87	-1.0	-0.87	-0.5	0	0.5	0.87	1.0
$2 \cos \frac{1}{2} x^{\circ}$	2.00	1.93	1.73	1.41	1.0	0.52	0	0.52	-1.00	1.47	1.73	1.93	-2.00

Using the scale 1 cm to represent 30° on the horizontal axis and 4 cm to represent 1 unit on the vertical axis draw, on the grid provided, the graphs of $y = \cos x^{\circ}$ and $y = 2 \cos \frac{1}{2} x^{\circ}$ on the same axis.

- (a) Find the period and the amplitude of $y = 2 \cos \frac{1}{2} x^{\circ}$
- (b) Describe the transformation that maps the graph of $y = \cos x^{\circ}$ on the graph of $y = 2 \cos \frac{1}{2} x^{\circ}$

19. An institute offers two types of courses technical and business courses. The institute has a capacity of 500 students. There must be more business students than technical students but at least 200 students must take technical courses. Let x represent the number of technical students and y the number of business students.

- (a) Write down three inequalities that describe the given conditions
- (b) On the grid provided, draw the three inequalities
- (c) If the institute makes a profit of Kshs 2,500 to train one technical student and Kshs 1,000 to train one business student, determine
 - (i) the number of students that must be enrolled in each course to maximize the profit
 - (ii) The maximum profit.

20. In the figure below PQR is the tangent to circle at Q. TS is a diameter and

TSR and QUV are straight lines. QS is parallel to TV. Angles $SQR = 40^\circ$ and angle $TQV = 55^\circ$

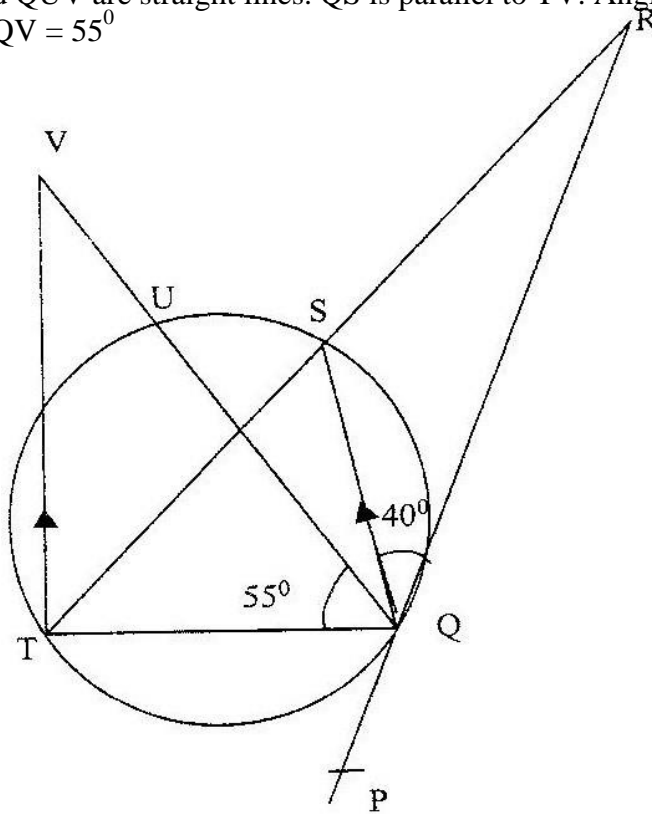

Find the following angles, giving reasons for each answer

- (a) $\angle QST$
- (b) $\angle QRS$
- (c) $\angle QVT$
- (d) $\angle UTV$

21. The volume $v\text{cm}^3$ of a solid depends partly on r^2 and partly on r^3 where r cm is one of the dimensions of the solid

When $r = 1$, the volume is 54.6 cm^3 and

When $r = 2$, the volume is 226.8 cm^3

- (a) Find the expression for v in terms of r
- (b) Calculate the volume of the solid when $r = 4$
- (c) Find the value of r for which the two parts of the volume are equal

QUESTIONS
SECTION 1 (52 Marks)

Answer all the questions in this section

1. Evaluate without using mathematical tables

$$\left(1000 \sqrt{\frac{0.0128}{200}} \right)$$

2. Factorize $a^2 - b^2$

Hence find the exact value of $2557^2 - 2547^2$

3. The mass of 6 similar books and 4 similar biology books is 7.2 kg. The mass of 2 such art books and 3 such biology books is 3.4 kg. Find the mass of one art book and mass of one biology book.

4. In the figure below, AB is parallel to DE, DE bisects angle BDG, angle DCF = 60° and angle CFG = 110°

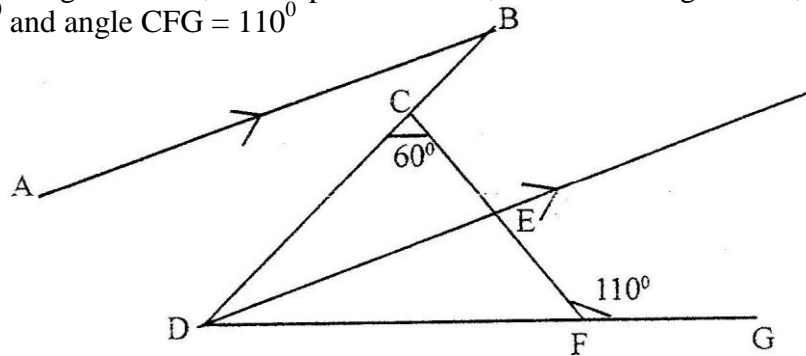

Find

(a) \angle CDF

(b) \angle ABD

Give reasons for your answers

5. A salesman gets a commission of 2.4% on sales up to Kshs 100.00. He gets an additional commission of 1.5% on sales above this. Calculate the commission he gets on sales worth Kshs 280.000
6. A point A is directly below a window. Another point B is 15 m from A and at the same horizontal level. From B angle of elevation of the top of the bottom of the window is 30° and the angle of elevation of the top of the window is 35° . Calculate the vertical distance.
- (a) From A to the bottom of the window

(b) From the bottom to top of the window

7. A matrix A is given by $A = \begin{pmatrix} x & 0 \\ 5 & y \end{pmatrix}$

- a) Determine A^2
- b) If $A^2 = \begin{pmatrix} & \\ 0 & \end{pmatrix}$, determine the possible pairs of values of x and y¹
- 0 1

8. Given that $\log y = \log (10^n)$ make n the subject

9. A quantity T is partly constant and partly varies as the square root of S.

- a) Using constants a and b, write down an equation connecting T and S.
- b) If S = 16, when T = 24 and S = 36 when T = 32, find the values of the constants a and b,

10. The third and fifth term of an arithmetic progression are 10 and -10 respectively

- a) Determine the first and the common difference
- b) The sum of the first 15 terms

11. A cylindrical container of radius 15cm has some water in it. When a solid is submerged into the water, the water level rises by 1.2 cm.

- (a) Find, the volume of the water displaced by the solid leaving your answer in terms of π
- (b) If the solid is a circular cone of height 9 cm, calculate the radius of the cone to 2 decimal places.

12. Six weeks after planting the height of bean plants were measured correct to the nearest centimeter. The frequency distribution is given in the table below.

Height (x)	$0 \leq x \leq 4$	$4 \leq x \leq 8$	$8 \leq x \leq 12$	$12 \leq x \leq 16$	$16 \leq x \leq 20$
Frequency	3	8	19	14	6
Cumulative Frequency					

- (a) Enter the cumulative frequency values in the above table
- (b) Estimate the median height of the plants

13. A financial institution charges compound interest on money borrowed. A business woman borrowed Kshs. 16, 000 from the financial institution. She paid back Kshs 25,000 after 2 years. Find the interest rate per annum.
14. Solve the equation $\cos (3\theta + 120^\circ) = \sqrt{3}/2$ for $0 \leq \theta \leq 180^\circ$
15. The radius of circle is given as 2.8 cm to 2 significant figures
- If C is the circumference of the circle, determine the limits between which C/π lies
 - By taking π to be 3.142, find, to 4 significant figures the line between which the circumference lies.
16. A and B are towns 360 km apart. An express bus departs from A at 8 am and maintains an average speed of 90 km/h between A and B. Another bus starts from B also at 8 am and moves towards A making four stops at four equally spaced points between B and A. Each stop is of duration 5 minutes and the average speed between any two spots is 60 km/h. Calculate distance between the two buses at 10 am.
17. Wainaina has two dairy farms. A and B. Farm A produces milk with $3\frac{1}{2}$ percent fat and farm B produces milk with $4\frac{3}{4}$ percent fat.
- Determine
 - The total mass fat in 50 kg of milk from farm A and 30 kg of milk from farm B
 - The percentage of fat in a mixture of 50 kg of milk from A and 30 kg of milk from B
 - Determine the range of values of mass of milk from farm B that must be used in a 50 kg mixture so that the mixture may have at least 4 percent fat.
18. The table below shows monthly income tax rates

Monthly taxable pay K £	Rate of tax Kshs per £
1 - 342	2
343 - 684	3
685 - 1026	4
1027-1368	5
1369 - 1710	6
Over 1710	

A civil servant earns a monthly salary of Kshs 20,000 and is provided with a house at a nominal rent of Kshs 700 per month

- Taxable pay is the employee's salary, plus 15% of salary, less nominal rent.

Calculate the civil servant's taxable pay in K £

- (b) Calculate the total tax
- (c) If the employee is entitled to a personal relief of Kshs. Per month, what is the net tax.

19. A quadrilateral ABCD has vertices A (4, -4), B(2, -4), C(6, -6) and D (4, -2)

- (a) On the grid provided draw the quadrilateral ABCD.
- (b) A'B'C'D is the image of ABCD under positive quarter turn about the origin. On the same grid draw the image A'B'C'D
- (c) A'B'C'D' is the image of A' B' C' D' under the transformation $\begin{pmatrix} & \\ 0 & 1 \end{pmatrix}$ given by the matrix $\begin{pmatrix} 1 & -2 \\ & \end{pmatrix}$

- (i) determine the coordinators of A'' B'' C'' D''
- (ii) On the same grid draw the quadrilateral A'' B'' C'' D''

(d) Determine a single matrix that maps ABCD onto A'' B''C''D''

20. The position of two towns X and Y are given to the nearest degree as X (45° N, 10°W) and Y (45° N, 70°W)

Find

- (a) The distance between the two towns in
 - (i) Kilometers (take the radius of the earth as 6371)
 - (ii) Nautical miles (take I nautical mile to be 1.85 km)
- (c)

The local time at X when the local time at Y is 2.00 pm.

21. A cyndrical can has a hemisphere cap. The cylinder and the hemisphere are of radius 3.5 cm.

The cylindrical part is 20 cm tall.

Take π to be $\frac{22}{7}$ calculate

- (a) the area of the circular base
- (b) the area of the curved cylindrical surface
- (c) the area of the curved hemisphere surface
- (d) The total surface area.

22. The figure below shows a grid of equally spaced parallel lines
 $AB = a$ and $BC = b$

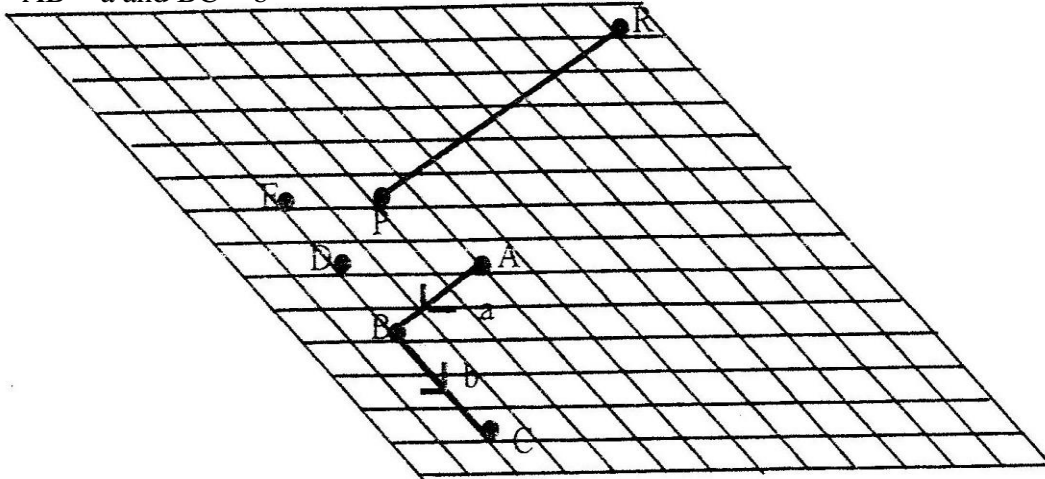

- (a) Express
 (i) AC in terms of a and b
 (b) Using triangle BEP , express BP in terms of a and b
 (c) PR produced meets BA produced at X and $Pr = \frac{1b}{9} - \frac{8a}{3}$

By writing PX as kPR and BX as hBA and using the triangle BPX determine the ratio $PR:RX$

23. Use a ruler and a pair of compasses only for all constructions in this question.
- (a) On the line BC given below, construct triangle ABC such that $\angle C = 30^\circ$ and $BA = 12$ cm
- (b) Construct a perpendicular from A to meet BC produced at D . Measure CD
- (c) Construct triangle $A'B'C'$ such that the area of triangle $A'B'C'$ is the three quarters of the area of triangle ABC and on the same side of BC as triangle ABC .
- (d) Describe the locus of A'

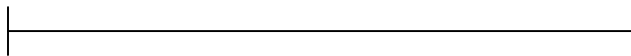

24. In a livestock research stations a new drug for a certain fowl disease is being tried. A sample of 36 fowls were diagnosed to have the disease. Twenty (20) fowls were treated with the drug and the rest were not.
- (a) Calculate the probability that a fowl picked at random is

- (i) treated with the drug
- (ii) Not treated with the drug

25. If a fowl is treated, probability of dying is $\frac{1}{10}$ while if not treated the probability is $\frac{7}{10}$ calculate the probability that, a fowl picked at random from the 36 fowl is

- (i) treated with the drug and will die
- (ii) Not treated with the drug and will die
- (iii) Not treated with the drug and will not die

MATHEMATICS PAPER 121/2 K.C.S.E. 1998
QUESTIONS
SECTION 1 (52 MARKS)

Answer the entire question in this section

1. Use logarithms to evaluate

$$55.9 \div (0.2621 \times 0.01177)^{1/5}$$

2. Simplify the expression $\frac{x-1}{x} - \frac{2x+1}{3x} \times 3x$

Hence solve the equation $\frac{x-1}{x} - \frac{2x+1}{3x} = \frac{2}{3}$

3. Simplify as far as possible, leaving your answer in the form of surd

$$\frac{1}{\sqrt{4-2\sqrt{3}}} - \frac{1}{\sqrt{14+2\sqrt{3}}}$$

4. In 30° ,
DC =

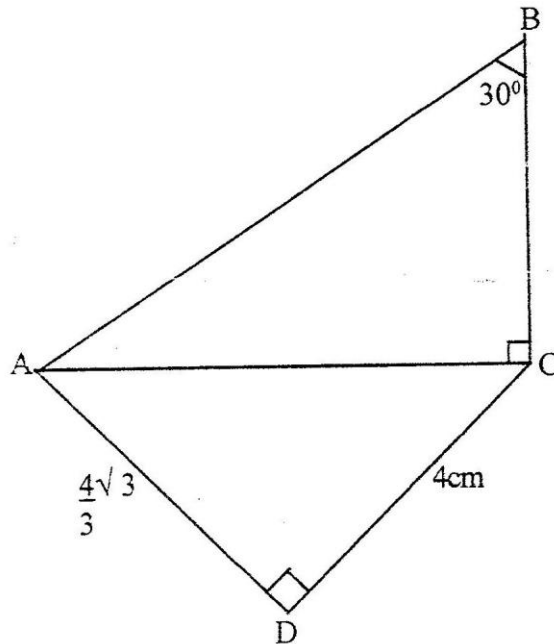

the figure below $ABC =$
 $ACB = 90^\circ$, $AD = 4\sqrt{3}$ and
4cm

$$\frac{8 + \sqrt{3}}{\sqrt{3}}$$
 if A is lost

- Calculate the length of (a) AC
(b) BC

5. A plot of land was valued at Kshs 50,000 at the start of 1994. It appreciated by 20% during 1994. Thereafter, every year, it appreciated by 10% of its previous years value.
- The value of the land at the start of 1995
 - The value of the land at the end of 1997
6. During a certain period, the exchange rate were follows
- 1 sterling pound = Kshs. 102.0
 - 1 sterling pound = Kshs. U.S dollar
 - 1 U.S dollar = Kshs. 60.6

A school management intended to import textbooks worth Kshs 500,00 from U.K. It changed the money to sterling pounds. Later the management found out that books were cheaper in U.S.A. Hence it changed the sterling pounds to dollars. Unfortunately, a financial crisis arose and the money had to be reconverted to Kenya shillings.

Calculate the total amount of money the management ended up with

7. A manufacturer sells bottle of fruit juice to a trader at a profit of 40%. The trader sells it for Kshs 84 at a profit of 20%. Find
- The trader's buying price
 - The cost of manufacture of one bottle

8. In the figure below a line XY and three points. A,B and C are given. On the figure construct
- The perpendicular bisector of AB
 - A point P on line xy such that $\angle APB = \angle ACB$

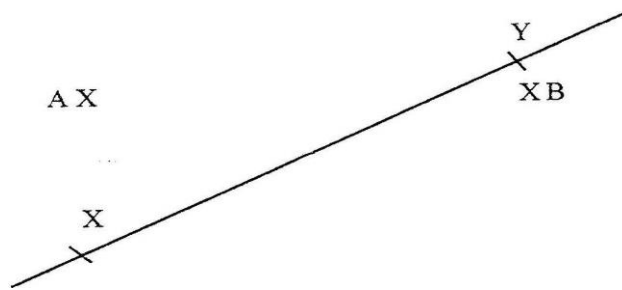

9. In the figure, KLMN is a trapezium in which KL is parallel to NM and $KL = 3NM$

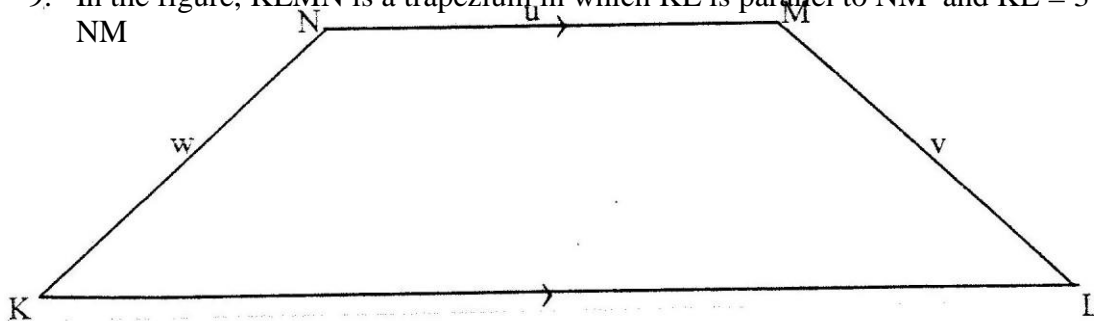

Given that $KN = w$, $NM = u$ and $ML = v$

Show that $2u = v = w$

10. Given that $P = 3^y$ express the equation $3^{2y-1} + 2 \times 3^{y-1} = 1$ terms of AP Hence or otherwise find the value of y in the equation $3^{2y-1} + 2 \times 3^{y-1} = 1$
11. A balloon, in the form of a sphere of radius 2 cm, is blown up so that the volume increase by 237.5%. Determine the new volume of balloon in terms of π
12. Find x if $-3 \log 5 + \log x^2 = \log \frac{1}{125}$
13. (a) Write down the simplest expansion $(1 + x)^6$

(b) Use the expansion up to the fourth term to find the value of $(1.03)^6$ to the nearest one thousandth.

14. A science club is made up of boys and girls. The club has 3 officials. Using a tree diagram or otherwise find the probability that:

(a) The club officials are all boys

(b) Two of the officials are girls

15. A river is flowing at uniform speed of 6 km/h. A canoeist who can paddle at 10 km/h through still water wishes to go straight across the river.

Find the direction, relative to the bank in which he should steer.

16. The triangular prism shown below has sides $AB = DC = EF = 12$ cm. The ends are equilateral triangles of sides 10 cm. The point N is the midpoint of FC.

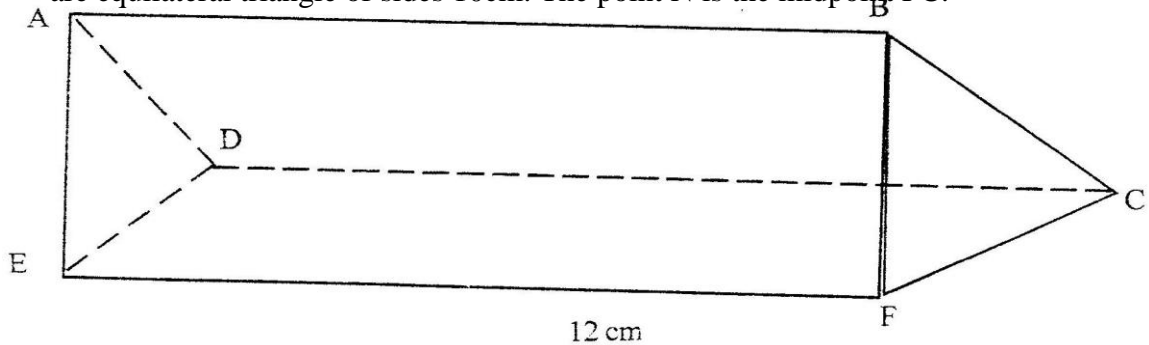

(a) Find the length of

(i) BN

(ii) EN

(b) Find the angle between the line EB and the plane CDEF

SECTION II (48 marks)

Answer any six questions from this section

17. A cylindrical water tank is a diameter 7 meters and height 2.8 metre

(a) Find the capacity of the water tank in litres

(b) Six members of a family use 15 litres per day. Each day 80 litres are used for cooking and washing and a further 60 litres are wasted. Find the number of complete days a full tank of water would last the family.

18. (a) Complete the table below for the value of $y = 2 \sin x + \cos x$.

x	0°	30°	45°	60°	90°	120°	135°	150°	180°	225°	270°	315°	360°
$2 \sin x$	0		1.4	1.7	2	1.7	1.4	1	0		-2	-1.4	0
$\cos x$	1		0.7	0.5	0	-0.5	-0.7	-0.9	-1		0	0.7	1
y	1		2.1	2.2	2	1.2	0.7	0.1	-1		-2	-0.7	1

(b) Using the grid provided draw the graph of $y = 2 \sin x + \cos x$ for 0° . Take 1 cm represent 30° on the x-axis and 2 cm to represent 1 unit on the axis.

(c) Use the graph to find the range of x that satisfy the inequalities $2 \sin x \cos x > 0.5$

19. In the figure below, QOT is a diameter. $\angle QTR = 48^\circ$, $\angle TQR = 76^\circ$ and $\angle SRT = 37^\circ$

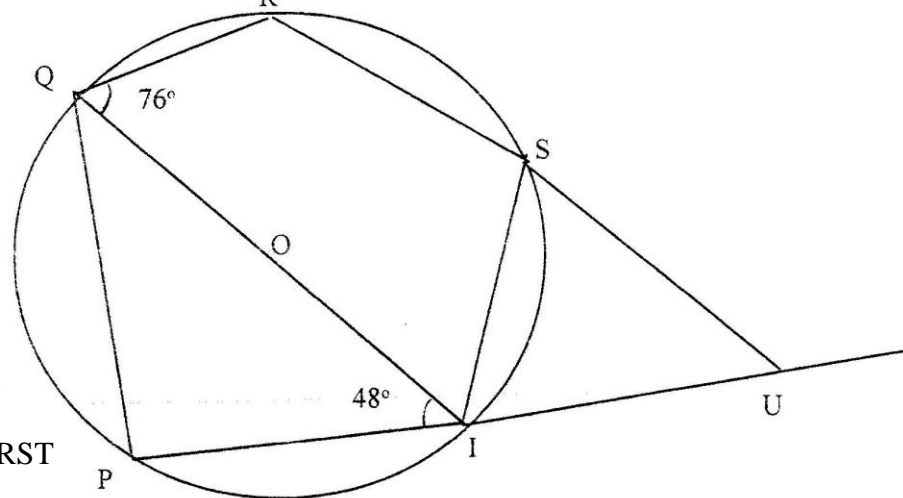

Calculate

(a) $\angle RST$

(b) $\angle SUT$

(c) Obtuse $\angle RUT$

(d) $\angle PST$

20. (a) Find the value of x at which the curve $y = x^2 - 2x - 3$ crosses the x - axis
 (b) $\int (x^2 - 2x - 3)dx$
 (c) Find the area bounded by the curve $y = x^2 - 2x - 3$, the axis and the lines $x = 2$ and $x = 4$

21. Two variables R and V are known to satisfy a relation $R = kV^n$, where k and n are constants. The table below shows data collected from an experiment involving the two variables R and V .

V	3	4	5	6	7	8
R	27	48	75	108	147	192

- (a) Complete the table of $\log V$ and R given below, by giving the value to 2 decimal places.

Log V	0.48	0.60	0.70	0.78	0.85	0.90
Log R	1.43	1.88	2.03	1.80	2.28	

- (b) On the grid provided draw a suitable straight line graph to represent the relation $R = kV^n$
 (c) (i) the gradient of the line
 (ii) a relationship connecting R and V .

22. Two aeroplane P and Q leaves an airport at the same time. P lies on a bearing of 240° at 900 km/ h while Q flies due east at 750 km/ h.
 (a) Using a scale of 1 cm to represents 100km, make a scale drawing to show the position of the aeroplane after 40 minutes.
 (b) Use the scale drawing to find the distance between the two aeroplane after 40 minutes.
 (c) Determine the bearing (i) P from Q
 (ii) Q from P

23. The figure below represents a rectangle PQRS inscribed in a circle centre O and radius 17cm . PQ = 16cm.

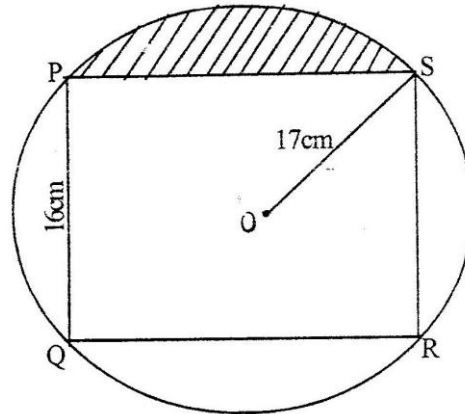

Calculate

- (d) The length PS of the rectangle
- (e) The angle POS
- (f) The area of the shaded region
24. A draper is required to supply two types of shirts A and type B. The total number of shirts must not be more than 400. He has to supply more type A than of type B however the number of types A shirts must be more than 300 and the number of type B shirts not be less than 80. Let x be the number of type A shirts and y be the number of types B shirts.

- (a) Write down in terms of x and y all the linear inequalities representing the information above.
- (b) On the grid provided, draw the inequalities and shade the unwanted regions

Type A: Kshs 600 per shirt

Type B: Kshs 400 per shirt

- (i) Use the graph to determine the number of shirts of each type that should be made to maximize the profit.
- (ii) Calculate the maximum possible profit.

MATHEMATICS PAPER 121/ 1 K.C.S.E 1999

QUESTIONS

Answer all questions in this section

1. (a) Evaluate

$$\frac{-8 \div 2 + 12 \times 9 - 4 \times 6}{56 \div 7 \times 2}$$

- (b) Simplify the expression

$$5a - 4b - 2[a - (2b + c)]$$

2. A point $(-5, 4)$ is mapped onto $(-1, -1)$ by a translation. Find the image of $(-4, 5)$ under the same translation.

3. Find by angles in the

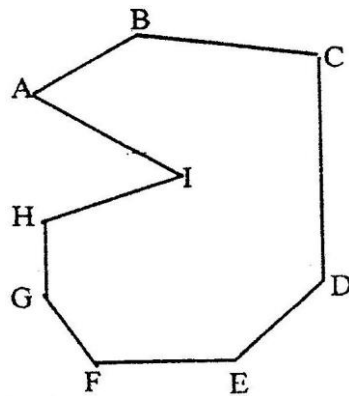

calculation the sum of all the interior angles in the figure ABCDEFGHI below

4. An open right circular cone has a base radius of 5 cm and a perpendicular height of 12 cm.

Calculate the surface area of the cone (take π to be 3.142)

5. The figure below is a map of a forest drawn on a grid of 1 cm squares

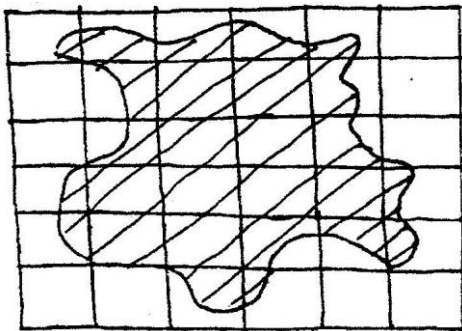

- (a) Estimate the area of the map in square centimeters
- (b) If the scale of the map is 1: 50,000 estimate the area of the forest in hectares
6. The table below shows the weight and price of three commodities in a given period

Commodity	Weight	Price Relatives
X	3	125
Y	4	164
Z	2	140

Calculate the retail index for the group of commodities

7. Two baskets A and B each contain a mixture of oranges and limes, all of the same size. Basket A contains 26 oranges and 13 limes. Basket B contains 18 oranges and 15 limes. A child selected a basket at random and picked a fruit at a random from it.

(a) Illustrate this information by a probabilities tree diagram

(b) Find the probability that the fruit picked was an orange

8. A girl wanted to make a rectangular octagon of side 14cm. She made it from a square piece of a card of size y cm by cutting off four isosceles triangles whose equal sides were x cm each, as shown below.

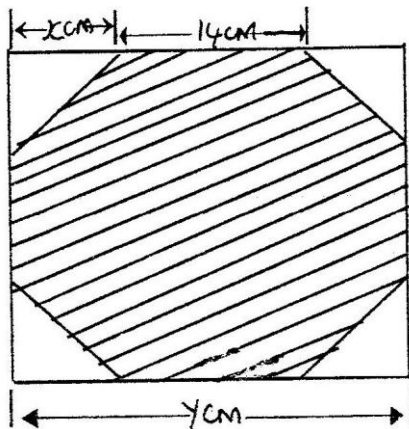

(a) Write down an expression for the octagon in terms of x and y

(b) Find the value of x

(c) Find the area of the octagon

9. The length and breadth of a rectangular floor were measured and found to be 4.1 m and 2.2 m respectively. If possible error of 0.01 m was made in each of the measurements, find the:

(a) maximum and minimum possible area of the floor

(b) Maximum possible wastage in carpet ordered to cover the whole floor

10. A business woman opened an account by depositing Kshs. 12,000 in a bank on 1st July 1995. Each subsequent year, she deposited the same amount on 1st July. The

bank offered her 9% per annum compound interest. Calculate the total amount in her account on

(a) 30th June 1996

(b) 30th June 1997

11. Given below is line BC. Without using a protractor construct another through B making an angle of $37\frac{1}{2}^{\circ}$ with BC. Using the constructed line subdivide BC into 7 equal parts.

B—————C

12. ABCD is a cyclic quadrilateral and AB is a diameter. Angle $\angle ADC = 117^{\circ}$ Giving reason for each step, calculate $\angle BAC$
13. An artisan has 63 kg of metal of density $7,000\text{kg/m}^3$. He intends to use to make a rectangular pipe with external dimensions 12 cm by 15 cm and internal dimensions 10 cm by 12 cm.
Calculate the length of the pipe in metres
14. An equilateral triangle ABC lies in a horizontal plane, A vertical flag AH stand at A.
If $AB = 2 AH$ find the angle between the planes ABC and HBC
15. By substituting triangle for $(2 - 0)$ or otherwise simplify the expression $(x + 2 - a)^2 + (2 - a - x)^2 - 2(x - 2 + a)(x + 2 - a)$. Give your answer in terms of a and as a product of two squares.
16. A particle moves on a straight line. The velocity after t seconds is given by $V = 3t^2 - 6t - 8$. The distance of the particle from the origin after one second is 10 metres. Calculate the distance of the particle from the origin after 2 seconds.

SECTION II (48 Marks)

Answer any six questions from this section

17. The cost of a minibus was Kshs. 950,000. It depreciated in value by 5% per year for the first two years by 15% per year for the subsequent years. (a) Calculate the value of the minibus after 5 years
- (b) After 5 years the minibus was sold through a dealer at 25% more than its value to Mr. X. If the dealers sale price was to be taken as its value after depreciation, calculate the average monthly rate of depreciation for 5 years.
18. A triangle plot of land ABC is such that $AB = 34\text{ m}$, $AC = 66\text{ m}$ and $\angle BAC = 96.70^{\circ}$
- (a) Calculate the length of BC

(b) In order to subdivide the plot, a fencing post P is located on BC such that $BP:PC = 1:3$. Calculate the area of the plot ABC and hence find the area of the triangular subdivision APB.

(c) A water pipe running through the subdivision APB is parallel to AB and divides the area in the ratio 4:5 where the bigger portion is a trapezium. Calculate the distance of the pipe from P.

19. The figure below shows two circles ABPQ and ABSR intersecting at A and B. PBS, QART and ABU are straight lines. The line UST is a tangent to a circle ABSR at S. $\angle BPQ = 80^\circ$, $\angle PBU = 115^\circ$ and $\angle BUS = 80^\circ$

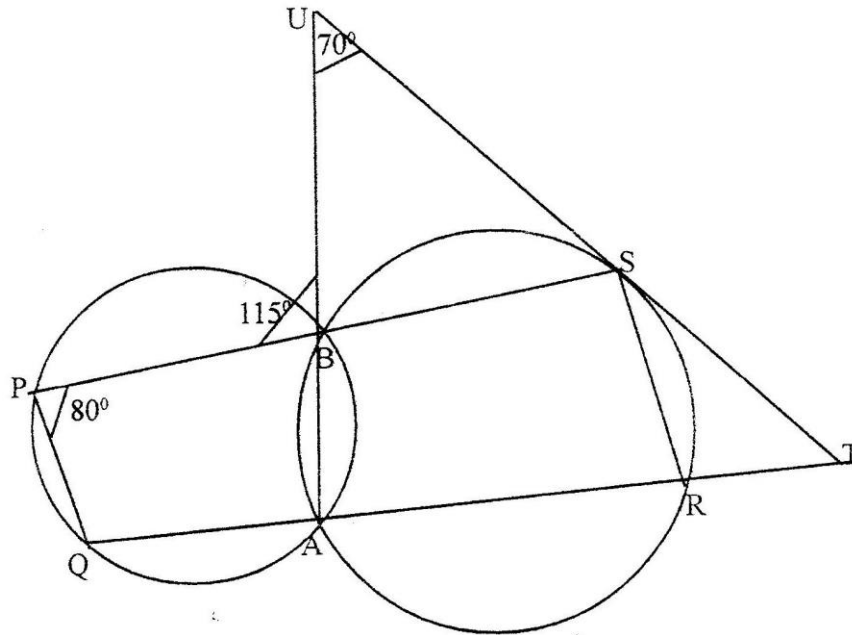

Find the values of the following angles, stating your reason in each case.

(a) $\angle BAR$

(b) $\angle STR$

(c) $\angle BSU$

20. (a) Complete the following table for the equation $y = x^3 - 5x^2 + 2x + 9$

x	-2	-1.5	-1	0	1	2	3	4	5
x^2		-3.4	-1	0	1		27	64	125
$-5x^2$	-20	-11.3	-5	0	-1	-20	-45		
2x	-4	-3		0	2	4	6	8	10
9	9	9	9	9	9	9	9	9	99
		-8.7			9	7		-3	

- (b) On the grid provided draw the graph of $y = x^3 - 5x^2 + 2x + 9$ for $-2 \leq x \leq 5$
- (c) Using the graph estimate the root of the equation $x^3 - 5x^2 + 2x + 9 = 0$ between $x = 2$ and $x = 3$
- (d) Using the same axes draw the graph of $y = 4 - 4x$ and estimate a solution to the equation $x^2 - 5x^2 + 6x + 5 = 0$

21. In triangle OAB, $OA = a$ $OB = b$ and P lies on AB such that $AP:BP = 3:5$

(a) Find the terms of a and b the vectors

- (i) AB
- (ii) AP
- (iii) BP
- (iv) OP

(b) Point Q is on OP such $AQ = \frac{-5a + 9b}{8 - 40}$

Find the ratio OQ: QP

22. If $x^2 + y^2 = 29$ and $x + y = 3$

(a) Determine the values of

- (i) $x^2 + 2xy + y^2$
- (ii) $2xy$
- (iii) $x^2 - 2xy + y^2$
- (iv) $x - y$

(b) Find the value of x and y

23. The diagram below shows a cross-section of a bottle. The lower part ABC is a hemisphere of radius 5.2 cm and the upper part is a frustrum of a cone. The top radius of the frustrum is one third of the radius of the hemisphere. The hemisphere part is completely filled water as shown in the diagram.

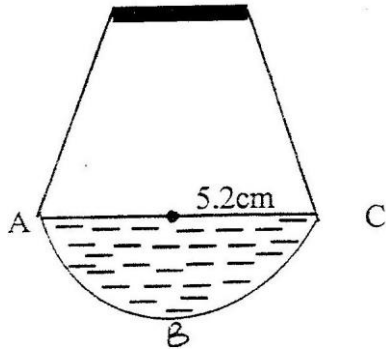

When the container is inverted, the water now completely fills only the frustum part.

- (a) Determine the height of the frustum part
- (b) Find the surface area of the frustum part of the bottle.

part ($2 \leq x \leq 8$) The quadratic part is $y = x^2 - 3x + 5$, $2 \leq x \leq 8$

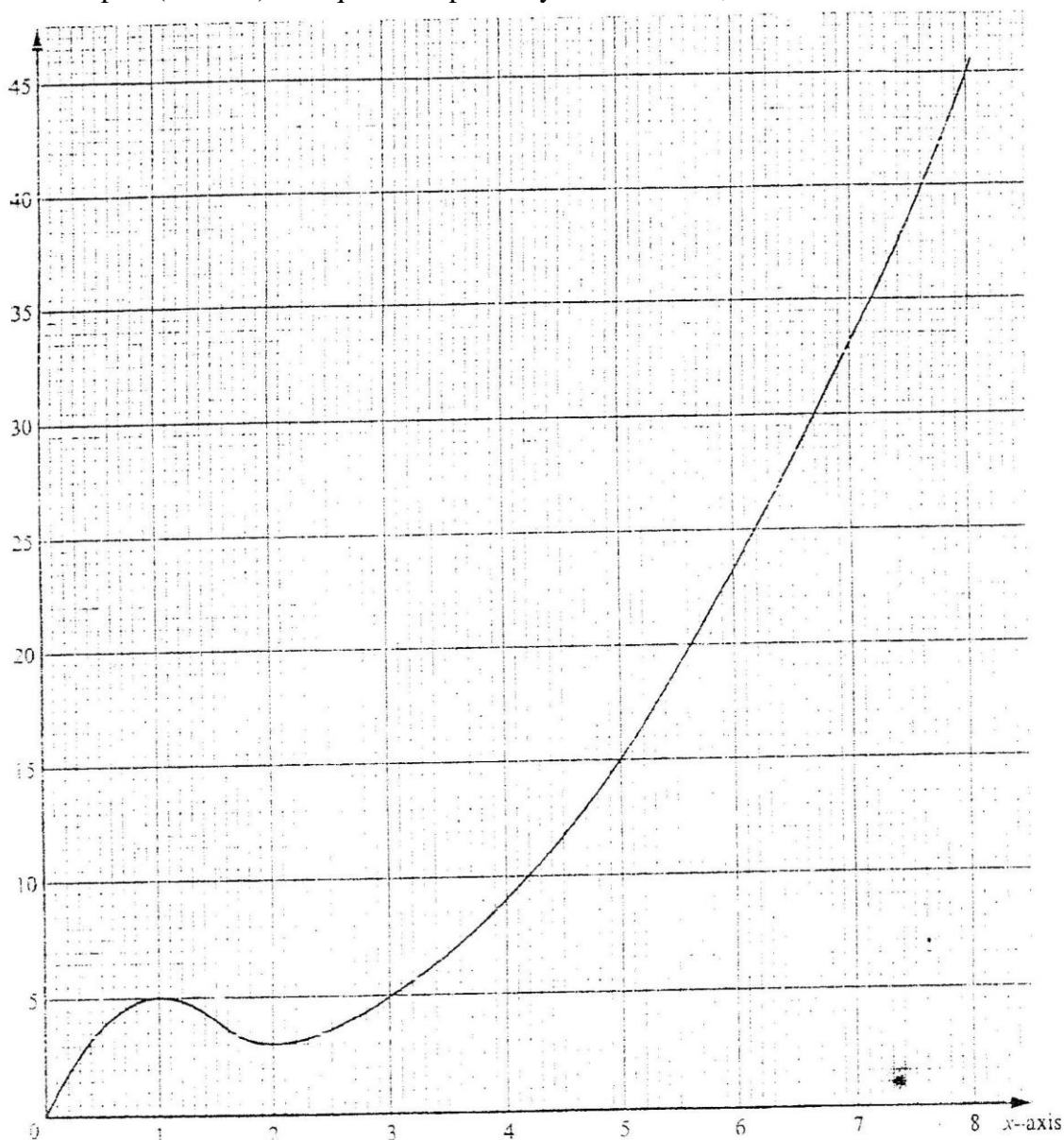

(a) Complete the table below

24. The graph below consists of a non-quadratic part ($0 \leq x \leq 2$) and a quadrant

x	2	3	4	5	6	7	8
y	3						

(1 mark)

(b) Use the trapezoidal rule with six strips to estimate the area enclosed by the curve, x = axis and the line $x = 2$ and $x = 8$ (3 marks)

(c) Find the exact area of the region given in (b) (3 marks)

- (d) If the trapezoidal rule is used to estimate the area under the curve between $x = 0$ and $x = 2$, state whether it would give an under- estimate or an over- estimate. Give a reason for your answer (1 mark)

MATHEMATICS PAPER 121/2 K.C.S.E 1999

MARKING SCHEME

SECTION 1 (52 Marks)

Answer all the questions in this section

1. Use logarithms to evaluate $\frac{6.79 \times 0.3911^{3/4}}{\text{Log } 5}$
2. Find the range of x if $2 \leq 3 - x < 5$
3. The mass of a mixture A of beans and maize is 72kg. The ratio of beans to maize is 3:5 respectively
 - (a) Find the mass of maize in the mixture
 - (b) A second mixture of B of beans and maize of mass 98 kg is mixed with A. The final ratio of beans to maize is 8:9 respectively. Find the ratio of beans to maize in B
4. Simplify $\sqrt{2x \times 5^{2x} 2^{-x}}$
5. In the month of January, an insurance salesman earned Kshs 6750 which was a commission of 4.5% of the premium paid to the company.
6. Solve for x $(\log_3 x)^2 - \frac{1}{2} \log_3 \frac{3}{2}$
7. The equation of a line is $-\frac{3}{5}x + 3y = 6$

Find the:

- (a) Gradient of the line
 - (b) Equation of a line passing through point (1,2) and perpendicular to the given line.
8. The figure below shows a solid made by passing two equal regular tetrahedra.

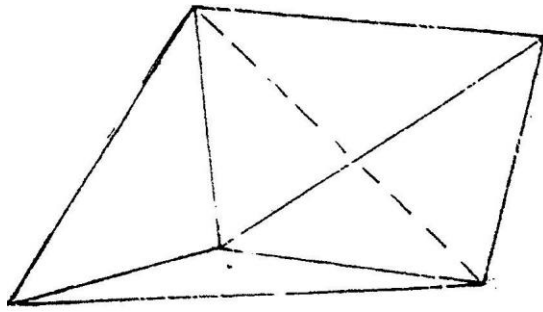

- (a) Draw a net solid
- (b) IF each face is an equilateral triangle of side 5cm find the surface area of the solid
9. Two towns A and B are 220km apart. A bus left town A at 11. 00am and traveled towards B at 60 km/h. At the same time, a matatu left town B for town A and traveled at 80 km/h. The matatu stopped for a total of 45 minutes on the way before meeting the bus. Calculate the distance covered by the bus before meeting the matatu.
10. Use binomial expression to evaluate $(0.96)^5$ correct to 4 significant figures 11. In the figure below triangle ABO represents a part of a school badge. The

badge has as symmetry of order 4 about O. Complete the figures to show the badge. B

A

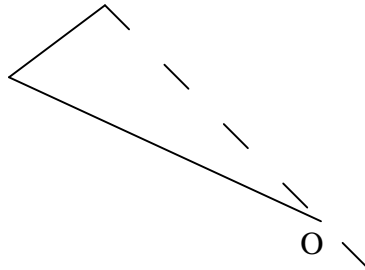

12. Solve the equation
 $8s^2 + 2s - 3 = 0$

Hence solve the equation C

$$8 \sin^2\theta + 2\sin\theta - 3 = 0 \text{ for } 0^\circ \leq \theta \leq 180^\circ$$

13. The number of people who attended an agricultural show in one day was 510 men, 1080 women and some children. When the information was represented on a pie chart, the combined angle for the men and children was 2160. find the angle representing the children.
14. The points P, Q and R lie on a straight line. The position vectors of P and R are $2i + 2j + 13k$ and $5i - 3j + 4k$ respectively. Q divides PR internally in the ratio 2:1 Find the

(a) Position vector of Q.

15. A construction firm has tractors T_1 and T_2 . Both tractors working together can complete a piece of work in 6 days while T_1 alone can complete the work in 15 days. After two tractors had worked together for four days, tractor T_1 broke down. Find the time it takes tractor T_2 to complete the remaining work

16. Find the equation of the tangent to the curve

$$Y = (x^2 + 1)(x - 2) \text{ when } x = 2$$

SECTION II (48 Marks)

Answer any six questions from this section

17. A retailer bought 49kg of grade 1 rice at Kshs. 65 per kilogram and 60 kg of grade II rice at Kshs 27.50 per kilogram. He mixed the two types of rice.

(a) Find the buying price of one kilogram of the mixture

(b) He packed the mixture into 2 kg packets

- (i) If he intends to make a 20% profit find the selling price per packet
- (ii) He sold 8 packets and then reduced the price by 10% in order to attract customers. Find the new selling price per packet.
- (iii) After selling of the remainder at reduced price, he raised the price so as to realize the original goal of 20% profit overall. Find the selling price per packet of the remaining rice.

18. A tower is on a bearing of 030° from a point P and a distance of elevation of the top is 15° and the angle of depression of the foot of the tower is 1° . a) Find the height of the tower

b) A point Q is on the same horizon plane as point P. The tower is on a bearing 330° from Q and at a distance of 70 m

19. Patients who attend a clinic in one week were grouped by age as shown in the table below:

Age x years	$0 \leq x < 5$	$5 \leq x < 15$	$15 \leq x < 25$	$25 \leq x < 45$	$45 \leq x < 75$
No. of patients	14	41	59	70	15

- i. Estimate the mean age

ii. On the grid provided draw a histogram to represent the distribution

1 cm to represent 5 unit on the horizon axis

2 cm to represent 5 units on the vertical axis

20. The first term of an arithmetic progression is 4 and the last term is 20. The sum of the term is 252. Calculate the number of terms and the common differences of the arithmetic progression

(b) An Experimental culture has an initial population of 50 bacteria. The population increased by 80% every 20 minutes. Determine the time it will take to have a population of 1.2 million bacteria.

21. The diagram below shows a garden drawn to scale of 1: 400. In the garden there are already tow trees marked A and B. The gardener wishes to plant more trees. There are a number of rules he wishes to apply.

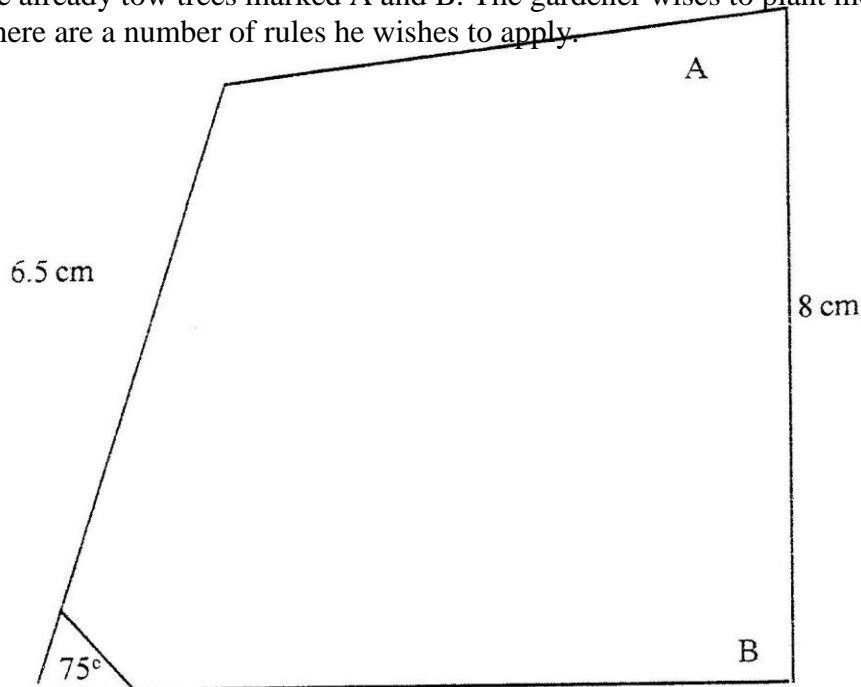

Rule 1: Each new tree must be an equal distance from both trees A and B.
Rule 2: Each new tree must be atleast 4 m from the edges of the garden. Rule 3: each new tree is atleast 14 m from tree B.

(a) draw the locus given by each of these rules on the diagram

(b) If the new trees are to be planted 4m apart, show on your diagram the possible planting points for the new trees.

22. (a) complete the table below, giving your values correct to 2 decimal places.

x	0	10	20	30	40	50	60	70
Tan x	0							
2x + 300	30	50	70	90	110	130	150	170
Sin (2x + 30°)	0.50			1				

- b) On the grid provided, draw the graphs of $y = \tan x$ and $y = \sin (2x + 30^\circ)$ for $0^\circ \leq x 70^\circ$
 Take scale: 2 cm for 100 on the x- axis
 4 cm for unit on the y- axis
 Use your graph to solve the equation $\tan x - \sin (2x + 30^\circ) = 0$
23. The transformation R given by the matrix
 $A = \begin{pmatrix} a & b \\ c & d \end{pmatrix}$ maps $\begin{pmatrix} 17 \\ 0 \end{pmatrix}$ to $\begin{pmatrix} 15 \\ 8 \end{pmatrix}$ and $\begin{pmatrix} 0 \\ 17 \end{pmatrix}$ to $\begin{pmatrix} -8 \\ \end{pmatrix}$
- (a) Determine the matrix A giving a,b,c and d as fractions
- (b) Given that A represents a rotation through the origin determine the angle of rotation
- (c) S is a rotation through 180° about the point (2, 3). Determine the image of (1,0) under S followed by R.
24. The diagram below shows a right pyramid VABCD with V as the vertex. The base of the pyramid is rectangle ABCD, WITH $ab = 4$ cm and $BC = 3$ cm. The height of the pyramid is 6cm.

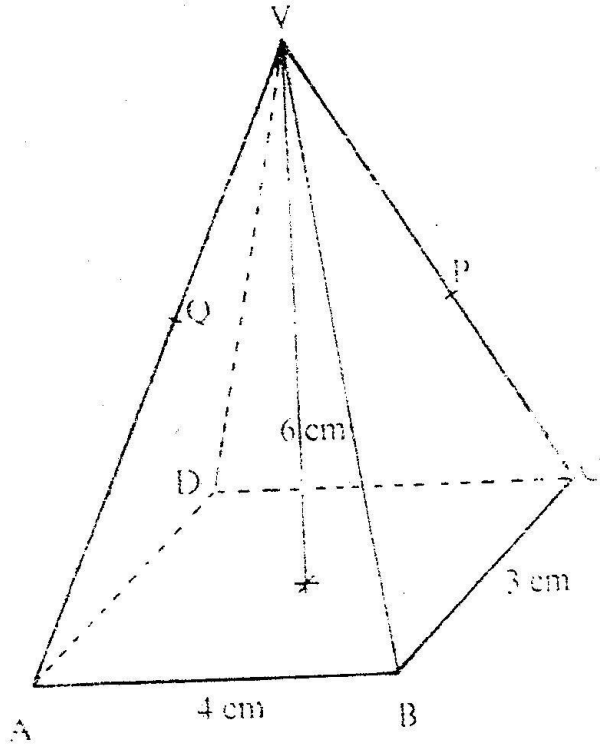

- (a) Calculate the
- (i) length of the projection of VA on the base
- (ii) Angle between the face VAB and the base
- (b) P is the mid- point of VC and Q is the mid – point of VD.
Find the angle between the planes VAB and the plane ABPQ

MATHEMATICS PAPER 121/1 K.C.S.E 2000

QUESTIONS

SECTION 1 (52 Marks)

Answer all the questions in this section

1. Evaluate $\frac{28 - (-18)}{-2} - \frac{15 - (-2)}{-3} (-6)$
2. Simplify the expression $\frac{3a^2 + 4ab + b^2}{4a^2 + 3ab - b^2}$

3. In the figure below ABCD is a rectangular pentagon and M is the midpoint of AB. DM intersects EB at N.

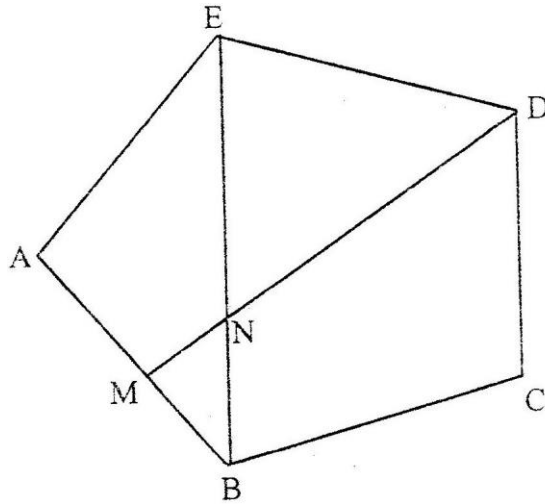

Find the size of:

- (a) $\angle BAE$
 (b) $\angle BED$
 (c) $\angle BNM$

4. The table below shows heights of 50 students

Height (cm)	Frequency
140 – 144	3
145 – 149	15
150- 154	19
155- 159	11
160-164	2

(a) State the modal class

(b) Calculate the median height

5. Find the value of x that satisfies the equation

$$\log (x + 5) = \log 4 - \log (x + 2)$$

6. The enclosed region shown in the figure below represent a ranch drawn to scale. The actual area of the ranch is 1075 hectares.

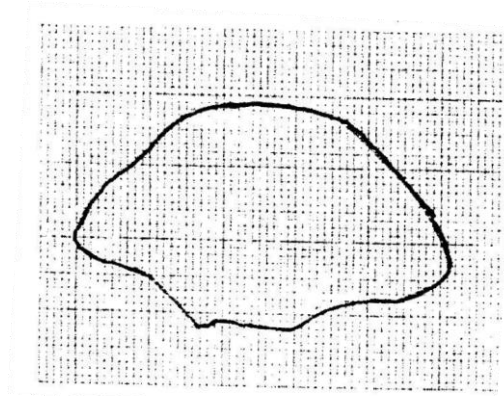

(a) Estimate the area of the enclosed region in square centimeters

(b) Calculate the linear scale used

7. Given that $\sin \theta = \frac{2}{3}$ and is an acute angle find:

(a) $\tan \theta$ giving your answer in surd form

(b) $\sec^2 \theta$

8. Shopping centers X, Y and Z are such that Y is 12 km south of X and Z is 15 km from X. Z is on a bearing of 330° from Y.

9. The figure below shows an octagon obtained by cutting off four congruent triangles from rectangle measuring 19.5 by 16.5 cm

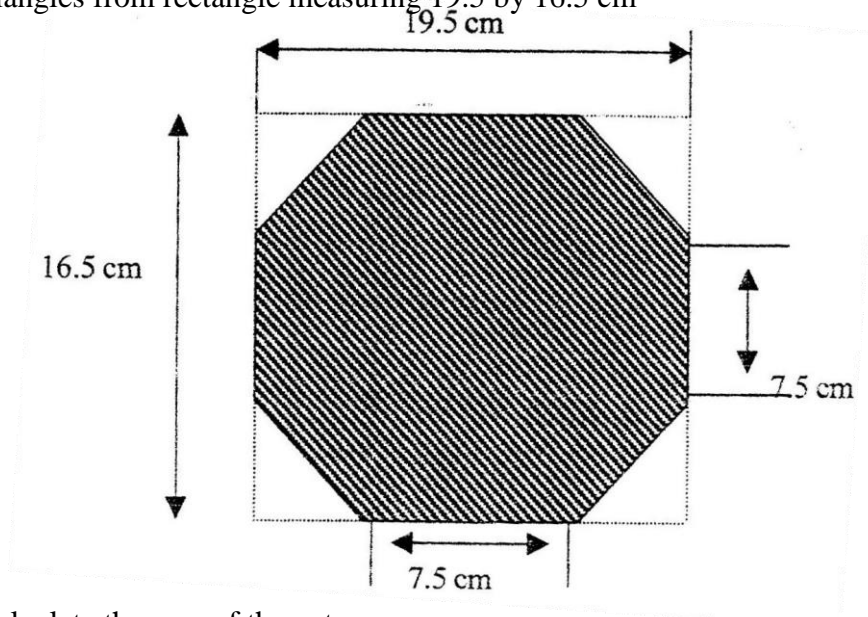

Calculate the area of the octagon

10. The length and breath of a rectangular paper were measured to be the nearest

centimeter and found to be 18cm and 12 cm respectively.

Find the percentage error in its perimeter.

11. A pyramid VABCD has a rectangular horizontal base ABCD with AB= 12 cm and BC = 9cm. The vertex V is vertically above A and VA = 6cm. calculate the volume of the pyramid.
12. A tailor intends to buy a sewing machine costs Kshs. 48,000. He borrows the money from a bank the loan has to be repaid at the end of the second year. The bank charges an interest at the rate of 24% per annum compounded half - yearly. Calculate the total amount payable to the bank.
13. On The figure below lines ABC and DC are tangents to the circle at B and D respectively

respectively $\angle ACD = 40^\circ$ and $\angle ABE = 60^\circ$

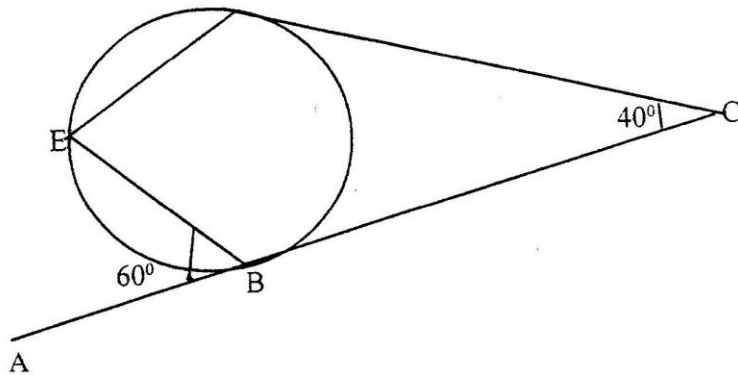

Giving reasons find the size of:

- (a) $\angle CBD$
- (b) $\angle CDE$

14. The acceleration m/s^2 of a particle moving in a straight line is given by $a = 18t - 4$, where t is time in seconds. The initial velocity of the particle is 2 m/s (a) Find the expression for velocity in terms of t

(b) Determine the time when the velocity is again 2m/s

15. Three people Korir, Wangare and Hassan contributed money to start a business. Korir contributed a quarter of the total amount and Wangare two fifths of the remainder. Hassan's contribution was one and a half times that of Korir. They borrowed the rest of the money from the bank which was Kshs 60, 000 less than Hassan's contribution, find the total amount required to start the business.

16. Karani bought 4 pencils and 6 biro- pens for Kshs 66b and Tachora bought 2 pencils and 5 biro- pens for Kshs 51.

(a) Find the price of each item

- (b) Musoma spent Kshs. 228 to buy the same type of pencils and biro pens. If the number of biro- pens he bought were 4 more than the number of pencils, find the number of pencils bought.

SECTION II (48 Marks)

Answer any six questions from this section 17. A triangular plot ABC is such that $AB = 36\text{m}$, $BC = 40\text{m}$ and $AC = 42\text{m}$ (a) Calculate the:

- (i) Area of the plot in square metres
 (ii) Acute angle between the edges AB and bc

- (b) A water tap is to be installed inside the plot such that the tap is equidistant from each of the vertices A, B and C. Calculate the distance of the tap.

18. In form 1 class there are 22 girls and boys. The probability of a girl completing the secondary education course is $\frac{3}{4}$ whereas that of a boy is $\frac{2}{3}$

- (a) A student is picked at random from class. Find the possibility that,
 (i) The student picked is a boy and will complete the course
 (ii) The student picked will complete the course
 (b) Two students are picked at random. Find the possibility that they are a boy and a girl and that both will not complete the course.

19. (a) Complete the table below for the equation $y = 2x^3 + 5x^2 - x - 6$

x	-4	-3	-2	-1	0	1	2
$2x^3$	-128	-54			0	2	16
$5x^3$	80	45	20	5	0	5	20
-x	4	3		0	-1		
-6	-6	-6	-6	-6	-6	-6	-6
y	-50		2	-6	0		

- (b) On the grid provided draw the graph $y = 2x^3 + 5x^2 - x - 6$ for $-4 \leq x \leq 2$
 (c) By drawing a suitable line use the graph in (b) to solve the equation $2x^3 + 5x^2 + x - 4 = 0$

20. A solid made up of a conical frustrum and a hemisphere top as shown in the figure below. The dimensions are as indicated in the figure.

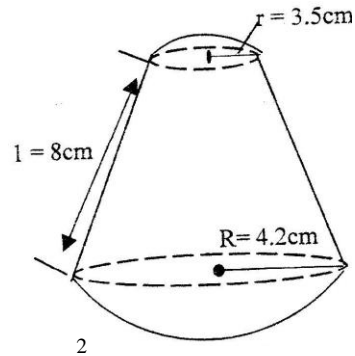

- (a) Find the area of
- The circular base
 - The curved surface of the frustrum
 - The hemisphere surface
- (b) A similar solid has a total area of 81.51 cm^2 . Determine the radius of its base.

21. The figure below shows triangle OAB in which M divides OA in the ratio 2:3 and N divides OB in the ratio 4:1 AN and BM intersect at X

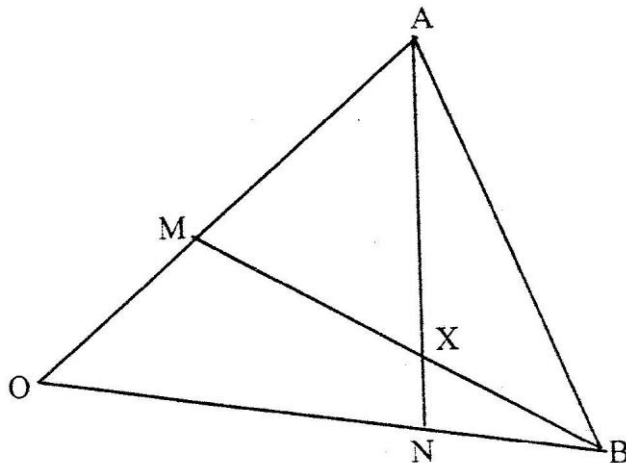

- (a) Given that $OA = a$ and $OB = b$, express in terms of a and b :
- AN
 - BM
- (b) If $AX = s AN$ and $BX = t BM$, where s and t are constants, write two expressions for OX in terms of a, b, s and t
- Find the value of s
- Hence write OX in terms of a and b

22. A plane leaves an airport A ($38.5^\circ \text{N}, 37.05^\circ \text{W}$) and flies due North to a point B on latitude 52°N .

- Find the distance covered by the plane
- The plane then flies due east to a point C, 2400km from B. Determine the position of C

Take the value π of as $\frac{22}{7}$ and radius of the earth as 6370 km

23. Matrix p is given by $\begin{pmatrix} 4 & 7 \\ 5 & 8 \end{pmatrix}$

- (a) Find P^{-1}
- (b) Two institutions, Elimu and Somo, purchase beans at Kshs. B per bag and maize at Kshs m per bag. Elimu purchased 8 bags of beans and 14 bags of maize for Kshs 47,600. Somo purchased 10 bags of beans and 16 of maize for Kshs. 57,400
- (c) The price of beans later went up by 5% and that of maize remained constant. Elimu bought the same quantity of beans but spent the same total amount of money as before on the two items. State the new ratio of beans to maize.
24. (a) Complete the table for the equation $Y = 2 \sin (3x + 30^\circ)$

X	0°	10°	20°	30°	40°	50°	60°	70°	80°	90°
$3x + 30^\circ$	30	60	90	120	150	180	210	240	270	300
$Y=2 \sin (3x + 30^\circ)$	1	1.73	2			0			-2	-1.73

- (b) Using the grid provided, draw the graph of $y = 2 \sin (3x + 30^\circ)$ for $0 \leq x \leq 90^\circ$ Take 1 cm to represent 50 on the x- axis and 2 cm to represent 1 unit on the y- axis
- (c) Use the graph in (b) to find the range of x that satisfy the inequality $y \geq 1.6$

MATHEMATICS PAPER 121/2 K.C.S.E 2000

QUESTIONS

SECTION 1 (52 Marks)

1. Find equation of the perpendicular to the line $x + 2y - 4$ and passes through point $(2,1)$
2. A passenger noticed that she had forgotten her bag in a bus 12 minutes after the bus had left. To catch up with the bus, she immediately took a taxi which traveled at 95 km/h. The bus maintained an average speed of 75 km/h. Determine
 - (a) The distance covered by the bus in 12 minutes
 - (b) The distance covered by the taxi to catch up with the bus
3. Two sides of a triangles are 5 cm each and the angle between them is 120° . Calculate the area of the triangle.
4. A piece of wire P cm long is bent to form the shape shown in the figure below

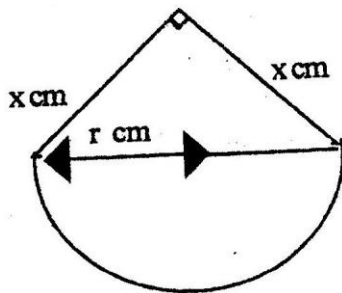

The figure consists of a semicircular arc of radius r cm and two perpendicular sides of length x cm each.

Express x in terms of P and r ,

Hence show that the area A cm², of the figures is given by $= \frac{1}{2} \pi r^2 + \frac{1}{8} (p - \pi r)^2$

5. The distance from a fixed point of a particular in motion at any time t seconds is given by

$$S = \frac{t^3 - 5t^2}{2} + 2t + 5$$

Find its:

- (a) Acceleration after 1 second
- (b) Velocity when acceleration is Zero
- (c) Find all the integral value of x which satisfy the inequalities

$$2(2-x) < 4x - 9 < x + 11$$

7. Akinyi, Bundi, Cura, and Diba invested some money on a business in the ratio of 7: 9:10:1 respectively. The business realized a profit of Kshs 46,800. They shared 12% of the profit equally and the remainder in the ratio of their contributions.

Calculate the total amount received by Diba

8. Solve the equation $2 \sin^2(x-30^\circ) = \cos 60^\circ$ for $-180^\circ \leq x \leq 180^\circ$
9. A triangle is formed by the coordinates A (2, 1) B(4,1) and C(1,6). It is rotated clockwise through 90° about the origin. Find the coordinates of this image.
10. Three representatives are to be selected randomly from a group of 7 girls and 8 boys. Calculate the probability of selecting two girls and one boy.

11. Use the logarithms to evaluate $\sqrt[3]{\frac{1.23 \times 0.0089}{76.54}}$

12. Find the value of x which satisfy the equation

$$5^{2x} - 6 \times 5^x + 5 = 0$$

13. Expand $(1 + x)^5$, hence, use the expansion to estimate $(1.04)^5$ correct to 4 decimal Places

14. In the figure below, BT is a tangent to the circle at B. AXCT and BXD are straight lines

AX = 6cm, CT = 8cm, BX = 4.8 cm and XD = 5cm.

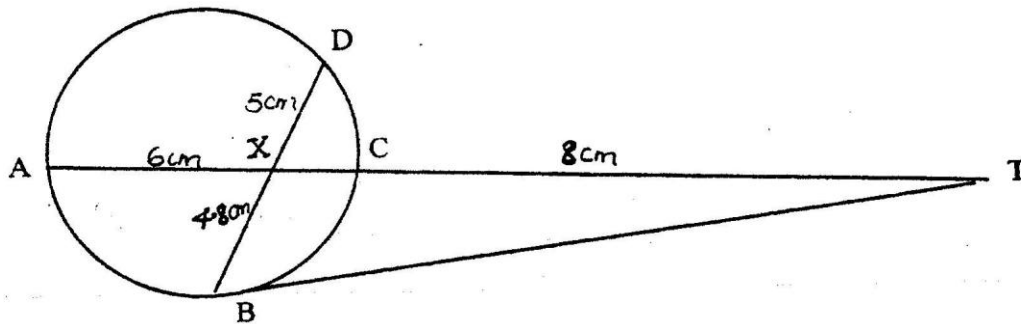

Find the length of

- (a) XC (b) BT

15. Make x the subject of the formula $p = \left(\frac{xy}{z+x} \right)^{\frac{1}{2}}$

16. The frequency distribution table below shows the weekly salary (K£) paid to workers in a factory

Salary (K£)	$50 \leq x < 100$	$100 \leq x < 150$	$150 \leq x < 25$	$250 \leq x < 350$	$350 \leq x < 500$
No. of workers	13	16	38	24	9

On the grid provided draw a histogram to respect the information shown above
SECTION II (48 Marks)

Answer any six questions from this section

17. A construction company requires to transport 144 tonnes of stones to sites A and B. The company pays Kshs 24,000 to transport 48 tonnes of stone for every 28 km. Kimani transported 96 tonnes to a site A, 49 km away.

- (a) Find how much he paid
- (b) Kimani spends Kshs 3,000 to transport every 8 tonnes of stones to site. Calculate his total profit.
- (c) Achieng transported the remaining stones to sites B, 84 km away. If she made 44% profit, find her transport cost.

18. A rally car traveled from point R to point S. S is 128 km on a bearing 060° from R. The car then set off S at 9.30 am towards T at an average of 150 km/h. It was expected at T at 11.30 am. After traveling for I hour and 20 minutes it broke down at point P. The bearing of T and P from S is 300° . Calculate the:

- (i) Distance from R to P
- (ii) Bearing of P and R
- (b) The repair took 10 minutes and the car set off to complete its journey to T. Find the speed at which car must now move to reach T on time.

20. The charge, C shillings per person for a certain seminar is partly fixed and partly inversely proportional to the total number N of people.

- (a) Write down the expression for C in terms of N
- (b) When 100 people attended the charge is Kshs 8,700 per person while for 35 people the charge is Kshs. 10,000 per person
- (c) If a person had paid the full amount and does not attend, the fixed charge is refunded. A group of people paid but ten per cent of them did not attend. After the refund the organizer remained with Kshs 574,000. Find the number of people initially in the group.

21. The curve of the equation $y = 2x + 3x^2$, has $x = -2/3$ and $x = 0$ and x intercepts.

The axis x shown below.

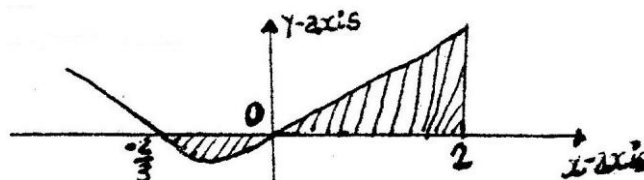

area bounded by the $x = -2/3$ and $x = 2$ is by the sketch

Find:

(a) $(2x + 3x^2) dx$

(b) The area bounded by the curve $x - axis$, $x = 2/3$ and $x = 2$

22. The line segment BC given below is one side of triangle ABC

- (a) Use a ruler and compasses to complete the construction of a triangle ABC in which $\angle ABC = 45^\circ$. $AC = 5.6$ cm and angle BAC is obtuse
- (b) Draw the locus of point P such that P is equidistant from a point O and passes through the vertices of triangle.
- (c) Locate point D on the locus of P equidistant from lines BC and BO. Q lies in the region enclosed by lines BD, BO extended and the locus of P. Shade the locus of Q.

23. The diagram on the grid provided below shows a trapezium ABCD

On the same grid

- (a) (i) Draw the image $A'B'C'D'$ of ABCD under a rotation of 90° clockwise about the origin.
(ii) Draw the image of $A''B''C''D''$ of $A'B'C'D'$ under a reflection in line $y = x$. State coordinates of $A''B''C''D''$.
- (b) $A''B''C''D''$ is the image of $A''B''C''D''$ under the reflection in the line $x=0$. Draw the image $A'''B'''C'''D'''$ and state its coordinates.
- (c) Describe a single transformation that maps $A''B''C''D''$ onto ABCD.

24. A theatre has a seating capacity of 250 people. The charges are Kshs. 100 for an ordinary seat and Kshs 160 for a special seat. It cost Kshs 16,000 to stage a show and the theater must make a profit. There are never more than 200 ordinary seats and for a show to take place at least 50 ordinary seats must be occupied. The number of special seats is always less than twice the number of ordinary seats.

- (a) Taking x to be the number of ordinary seats and y the number of special seats write down all the inequalities representing the information above. (b) On the grid provided, draw a graph to show the inequalities in (a) above
- (c) Determine the number of seats of each type that should be booked in order to maximize the profit.

MATHEMATICS PAPER 121/1 K.C.S.E 2001

QUESTIONS

SECTION 1 (52 Marks)

Answer all the questions in this section

1. Find the reciprocal of 0.342. Hence evaluate:

$$\frac{0.0625}{0.342}$$

2. The figure below represents a kite ABCD, AB = AD = 15 cm. The diagonals BD and AC intersect at O. AC = 30 cm and AO = 12 cm.

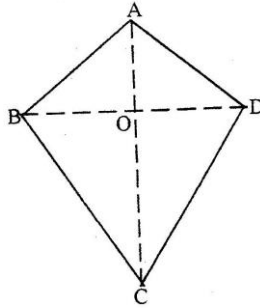

Find the area of the kite

3. Use logarithms to evaluate

$$(3.256 \times 0.0536)^{1/3}$$

4. The diagram below represents a solid made up of a hemisphere mounted on a cone. The radius of the hemisphere are each 6 cm and the height of the cone is 9 cm.

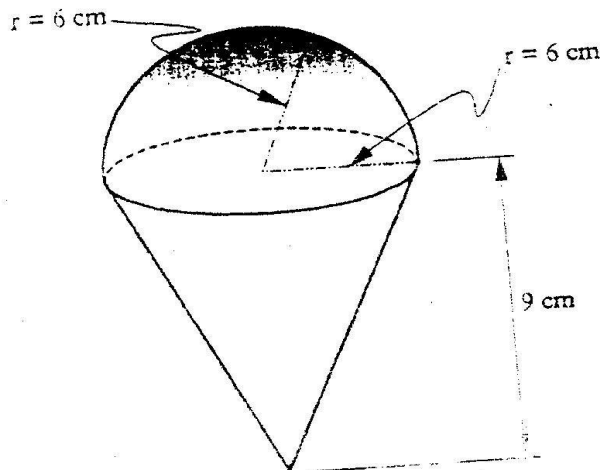

5. A line L_1 passes through point (1,2) and has a gradient of 5. Another line L_2 , is perpendicular to L_1 and meets it at a point where $x = 4$. Find the equation for L_2 in the form of $y = mx + c$
6. Simplify the expression
$$\frac{3x^2 - 4xy - y^2}{9x^2 - y^2}$$
7. The length of a room is 4 metres longer its width. Find the length of the room if its area is 32m^2

8. Use a ruler and compasses in this question. Draw a parallelogram ABCD in which $AB = 8$ cm, $BC = 6$ cm and $\angle BAD = 75^\circ$. By construction, determine the perpendicular distance between AB and CD.
9. A poultry farmer vaccinated 540 of his 720 chickens against a disease. Two months later, 5% of the vaccinated and 80% of the unvaccinated chicken, contracted the disease. Calculate the probability that a chicken chosen random contacted the disease.

10. Make x the subject of the formula

$$S = w\sqrt{a^2 - x^2}$$

11. A particle is projected from the origin. Its speed was recorded as shown in the table below

Time (sec)	0	5	10	15	20	25	30	35
Speed (m/s)	0	2.1	5.3	5.1	6.8	6.7	4.7	2.6

Use the trapezoidal rule to estimate the distance covered by the particle within the 35 seconds

12. Given that $\sin(x + 30^\circ) = \cos 2x^\circ$ for $0^\circ, 0^\circ \leq x \leq 90^\circ$ find the value of x . Hence find the value of $\cos^2 3x^\circ$.

13. Given that $P = \begin{pmatrix} 2 & 2 \\ 1 & 2 \end{pmatrix} \times 3$ and $Q = \begin{pmatrix} 2 & 2 \\ 1 & 2 \end{pmatrix} \times -3$, find the matrix product PQ

Hence, solve simultaneous equations below:

$$2x - 3y = 5$$

$$-x + 2y = -3$$

14. The interior angles of the hexagon are $2x^\circ, \frac{1}{2}x^\circ + 40^\circ, 110^\circ, 130^\circ$ and 160° . Find the value of the smallest angle
15. A town N is 340 km due west of town G and town K is due west of town N. A helicopter Zebra left G for K at 9.00 am. Another helicopter Buffalo left N for K at 11.00 am. Helicopter Buffalo traveled at an average speed of 20 km/h faster than Zebra. If both helicopters reached K at 12.30 pm find the speed of helicopter Buffalo.
16. The position vectors for points P and Q are $4\mathbf{i} + 3\mathbf{j} + 6\mathbf{k}$ respectively. Express vector PQ in terms of unit vectors \mathbf{i}, \mathbf{j} and \mathbf{k} . Hence find the length of PQ, leaving your answer in simplified form.

SECTION II (48 Marks)

Answer any six questions in this section

17. The table shows income tax rates

Monthly taxable pay	Rate of tax Kshs in 1 K£
1 – 435	2
436 – 870	3
871-1305	4
1306 – 1740	5
Excess Over 1740	6

A company employee earn a monthly basic salary of Kshs 30,000 and is also given taxable allowances amounting to Kshs 10, 480.

- (a) Calculate the total income tax
 - (b) The employee is entitled to a personal tax relief of Kshs 800 per month. Determine the net tax.
 - (c) If the employee received a 50% increase in his total income, calculate the corresponding percentage increase on the income tax.
18. The coordinates of the vertices of rectangle PQRS are P (1,1), Q (6,1), R (6,4) and S(1,4)

- (a) (i) Find the coordinates of its image $P''Q''R''S''$ of $P'Q'R'S'$ under the transformation given by the $\begin{pmatrix} \text{matrix} & 1 & -2 \\ 0 & 1 \end{pmatrix}$
- (ii) Draw the object and its image on the grade provide
- (iii) On the same grid draw $\begin{pmatrix} \text{the} \\ \text{matrix} \end{pmatrix}$ image. $P'' Q''R'' S''$ of $P' Q' R' S'$ under the transformation given by $\begin{pmatrix} 0 & 1 \\ -1 & 0 \end{pmatrix}$

- (b) Find a single matrix which will map $P'' Q'' R'' S''$ onto $P'R'S'Q'$

19. The figure below shows a parallelogram OPQR with O as the origin, $OP = p$ and $OR = r$, Point T divides RQ in the ratio 1: 4 PT Meets OQ at S.

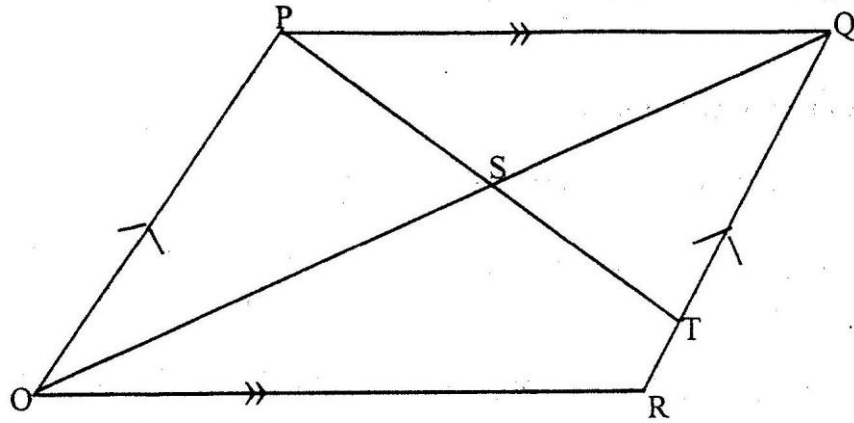

- (a) Express in terms of p and r the vectors
- OQ
 - OT
- (b) Vector OS can be expressed in two ways: mOQ or $OT + nTP$, Where m and n are constants express OS in terms of
- m, n and r
 - n, s and r Hence find the:
 - Value on m
 - Ratio $OS : SQ$

20. In the figure below, points O and P are centers of intersecting circles ABD and BCD respectively. Line ABE is a tangent to circle BCD at B . Angle $BCD = 42^\circ$

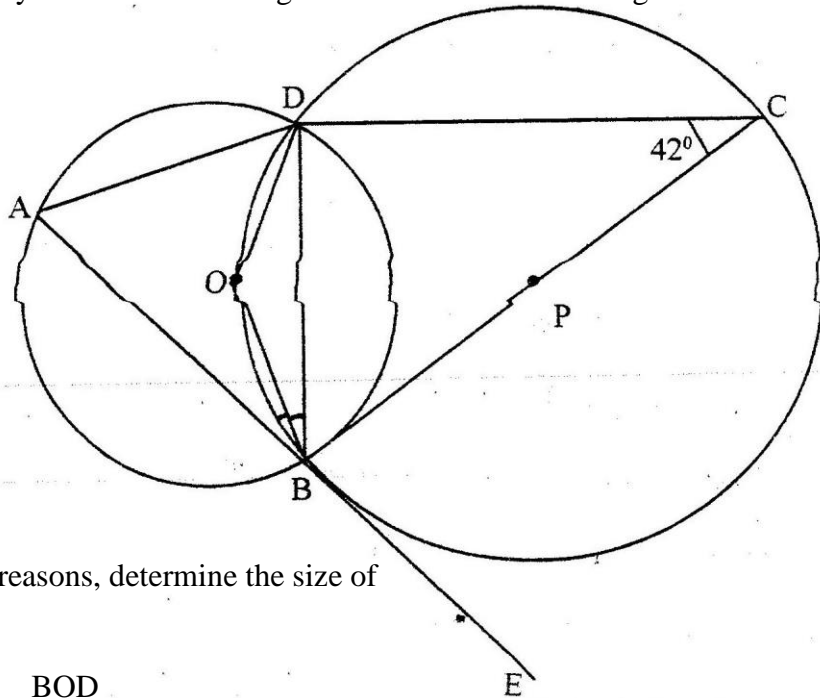

- Stating reasons, determine the size of $\angle GBD$
 - Reflex $\angle BOD$
- (b) Show that $\triangle ABD$ is isosceles
21. (a) The gradient function of a curve is given by $\frac{dy}{dx} = 2x^2 - 5$

Find the equation of the curve, given that $y = 3$, when $x = 2$

- (b) The velocity, v m/s of a moving particle after seconds is given: $v = 2t^3 + t^2 - 1$.
Find the distance covered by the particle in the interval $1 \leq t \leq 3$

22. (a) Complete the following table for the equation $y = x^3 + 2x^2$

x	-3	-2.5	-2	-1.5	-1	-0.5	0	1	1.5
x^3	-27		-8	-3.375	-1	0.125	0	0.125	3.375
$2x^2$	18		8	4.5	2	0.5	0	0.5	4.5
y	-9		0	1.125	1	0.375	0	0.625	7.875

- (b) On the grid provided draw the graph $y = x^3 + 2x^2$ for $-3 \leq x \leq 1.5$
Take the scale: 2cm for 1 unit on the X- axis and 1 cm for 1 unit on y – axis
- (c) By drawing a suitable line on the same grid, Estimate the roots of the equation: $X^3 + 2x^2 - x - 2 = 0$

23. The probability of three darts players Akinyi, Kamau, and Juma hitting the bulls eye are 0.2, 0.3 and 1.5 respectively.

(a) Draw a probability tree diagram to show the possible outcomes

(b) Find the probability that:

- (i) All hit the bulls eye
- (ii) Only one of them hit the bulls eye
- (iii) at most one missed the bull's eye

24. A plane flying at 200 knots left an airport A (30°S , 31°E) and flew due North to an airport B (30°N , 31°E)

- (a) Calculate the distance covered by the plane, in nautical miles (b) After a 15 minutes stop over at B, the plane flew west to an airport C (30°N , 13°E) at the same speed.

Calculate the total time to complete the journey from airport C, though airport B.

MATHEMATICS PAPER 121/2 K.C.S.E 2001 QUESTIONS

SECTION 1 (52 MARKS)

Answer all the questions in this section.

1. Evaluate $\frac{1}{3}$ of $(2\frac{3}{4} - 5\frac{1}{2}) \times 3\frac{6}{7} \div \frac{9}{4}$
2. Solve for x in the equation $32^{(x-3)} \div 8^{(x-4)} = 64 \div 2^x$
3. Three people Odawa, Mliwa and Amina contributed money to purchase a flour mill. Odawa contributed of the total amount, Mliwa contributed of the remaining amount and Amina contributed the rest of the money. The difference in contribution between Mliwa and Amina was shs.40,000.

Calculate the price of the flour mill.

4. Two variables A and B are such that A varies partly as the square of B. Given that A = 30, when B = 9, and A = 16 when B = 14, Find A and B = 36.
5. The figure below shows a net of a prism whose cross-section is an equilateral triangle.

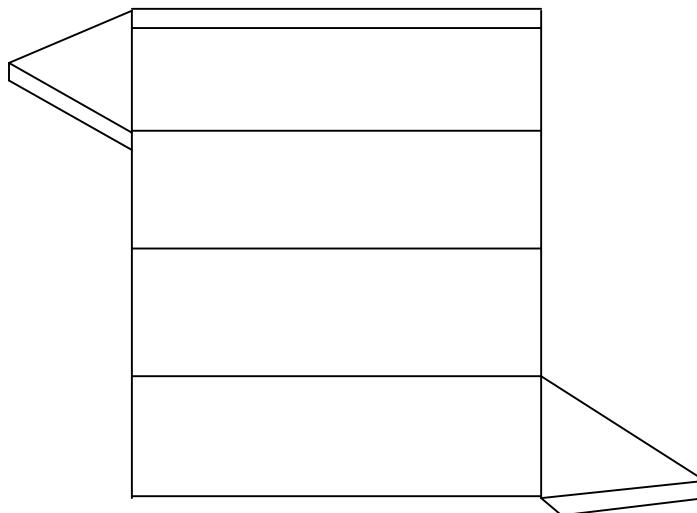

- a) Sketch the prism
 - b) State the number of planes of symmetry of the prism.
6. A telephone bill includes Ksh.4,320 for local calls, Ksh.3,260 for trunk calls and a rental charge of Kshs.2,080. A value added tax (V.A.T.) is then charge at 15%.
 7. A translation maps a point P (3,2) onto P' (9,5)
 - a) Determine the translation vector.
 8. Solve the equation $\log(x+24) - 2\log 3 = \log(9-2x)$

9. The table below shows the number of bags of sugar sold per week and their moving averages.

No. of bag as per week	340	330	x	342	350	345
Moving averages	331	332	Y	346		

- a) State the order of moving average
- b) Find the value of x and y
10. Expand $(2 + x)^5$ in ascending powers of x up to the term in x^3 . Hence, approximate the value of $(2.03)^5$ to 4s.f.
11. A curve is given by the equation: $u = 5x^3 - 7x^2 + 3x + 2$
- a) Gradient of the curve at $x = 1$

12. The figure represents a pentagon prism of length 12cm. The cross – section is a regular pentagon, centre O, whose dimensions are shown.

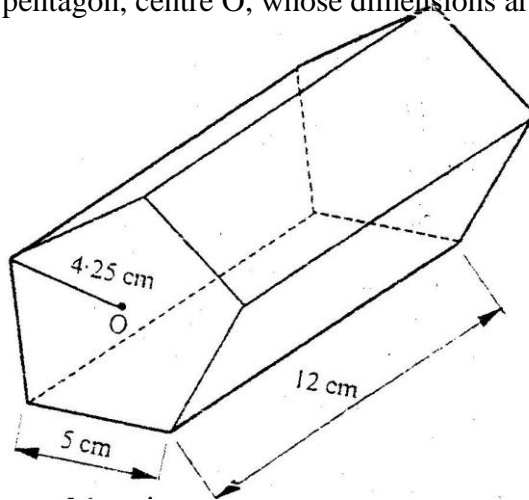

- Find the total surface area of the prism.
13. Given that $\tan 75^\circ = 2 + \sqrt{3}$, find without using tables $\tan 15^\circ$ in the form $p+q\sqrt{m}$, where p,q and m are integers.

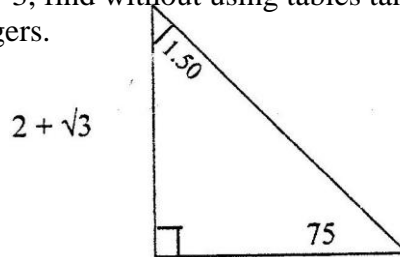

14. The diagram below represents a field PQR.

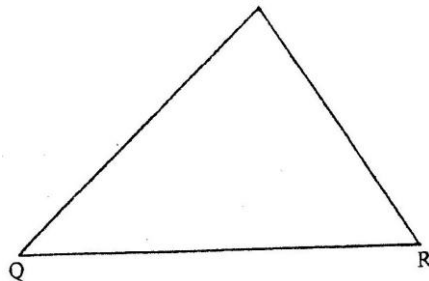

- Draw the locus of points equidistant from sides PQ and PR.
 - Draw the locus of points equidistant from points P and R.
 - a coin is lost within a region which is nearest to point P than to R and closer to side PR than to side PQ, shade the region where the coin can be located.
15. Solve the equation $4 \sin^2 \theta + 4 \cos \theta = 5$

16. The diagram below shows the graph of:
 $Y \geq \frac{3}{10}x - \frac{3}{2}$, $5x + 6y = 30$ and $x = 2$

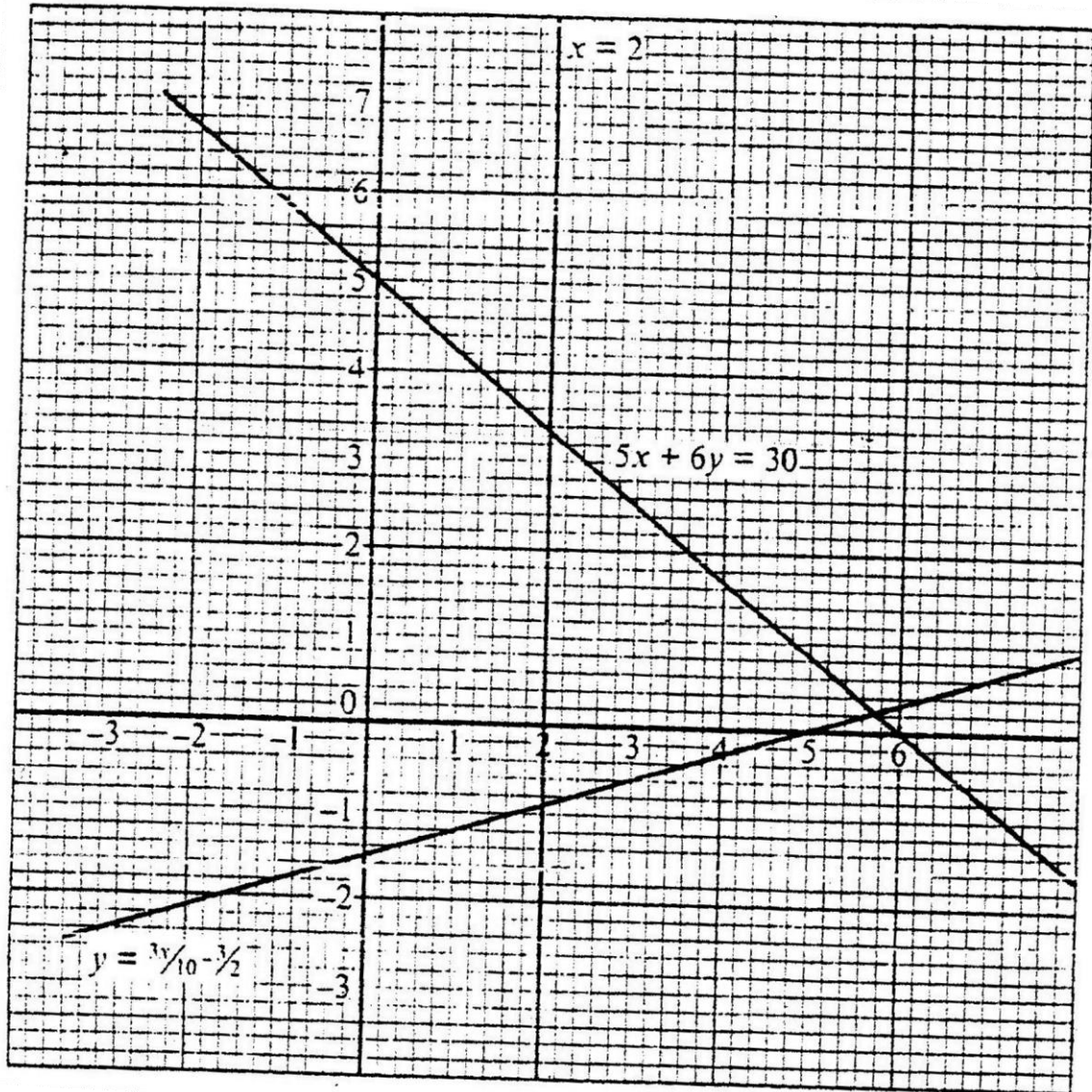

By shading the unwanted region, determine and label the region R that satisfies the three inequalities.

For $0^\circ \leq \theta < 360^\circ$ give the answer in degrees

$$Y \geq \frac{3}{10}x - \frac{3}{2}, + 6y \geq 30 \text{ and } x \geq 2$$

SECTION II (48 Marks) Answer any six questions in this section.

17. A helicopter is stationed at an airport H on a bearing 060° and 800km from another airport P. A third airport is J is on bearing of 140° and 1,200km from H.
- Determine:
 - Value of P

- ii) The bearing of P from J
18. The marks obtained by 10 pupils in an English test were 15,14,13,12,P,16,11,13,12 and 17. The sum of the squares of the marks, $\sum x^2 = 794$
- a) Calculate the:
- i) Value of P ii) Standard deviation.
- b) If each mark is increased by 3, write down the:
- i) New mean
- ii) New standard deviation
19. The n th term of a sequence is given by $2n+3$
- a) Write the first four items of the sequence.
- b) Find S_{50} , the sum of the first terms of the sequence.
- c) Show that the sum of the first terms of the sequence is given by.
- $$S_n = n^2 + 4n$$
- Hence or otherwise find the first largest integral value of n such that.
- $$S_n < 725$$
20. a) Distance from A and B
- b) bearing B from A
21. a) Complete the table given below in the blank spaces.

X	0°	15°	30°	45°	60°	75°	90°	105°	120°	135°	150°	165°	180°
$3 \cos 2x$	3	2.598	1.5	0	1.5	-3	-2.598	-1.5	0	2.598	3		
$2 \sin (2x + 30^\circ)$	1		2	2-732	1	0		-1	-1.732	-2	-2.732	-2	1

- b) On the grid provided draw, on the same axis, the graph of $y = 3 \cos 2x$ and $y = \sin(2x + 30^\circ)$ for $0^\circ \leq x \leq 180^\circ$. Take the scale: 1cm for 150° on the axis and 2cm for 1 unit on the y-axis.
- c) Use your graph to estimate the range of value of x for which $3 \cos 2x \leq 2 \sin (2x + 30^\circ)$.

Give your answer to the nearest degree.

22. The displacement x metres a particle after seconds given by.
- $$X = t^3 - 2t^2 + 6t > 0.$$
- a) Calculate the velocity of the particle in m/s when $t = 2$ seconds.
- b) When the velocity of the particle is zero, calculate its:-

- i) Displacement ii) Acceleration.

23. The diagram below represents a pillar made of cylindrical and regular hexagonal parts. The diameter and height of the cylindrical part are 1.4m and 1m respectively. The hexagonal face is regular with side length 0.4m and height of 4m.

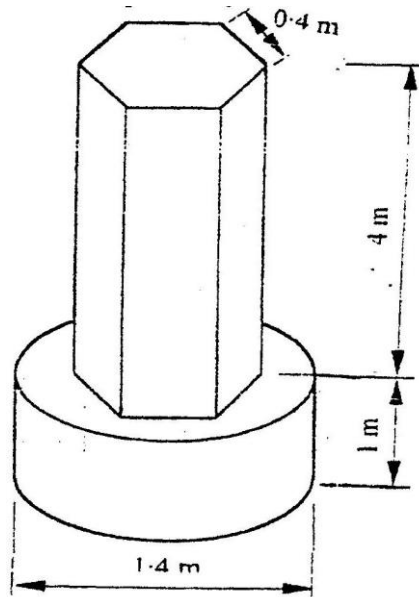

- a) Calculate the volume of the :
- Cylindrical part
 - Hexagonal part
- b) An identical pillar is to be built but with a hollow centre cross – section area of 0.25m^2 . The density of the material to be used to make the pillar is 2.4g/cm^3 . Calculate the mass of the new pillar.
24. Bot juice Company has two types of machines, A and B, for juice production. Type A machine can produce 800 litres per day while type B Machine produces 1,600 litres per day.

Type A machine needs 4 operators and type B machine needs 7 operators.

At least 8,000 litres must be produced daily and the total number of Operators should not exceed 41. There should be 2 more machines of each type.

Let x be the number of machines of type A and Y the number of machines for type B,

- Form all inequalities in x and y to represent the above information.
- On the grid provided below, draw the inequalities to shade the unwanted regions.

MARKING SCHEME K.C.S.E.2002

MATHEMATICS PAPER 1

1. Evaluate: $-12 - (-3) \times 4 - (-20)$ (3mks)
$$\frac{-6 \times 6 \div 3 + (-6)}{}$$
2. Simplify: $(x + 2y)^2 - (x - 2y)^2$ (3mks)
3. Make y the subject of the formula $p = \frac{xy}{x-y}$
4. The position vectors of points X and Y are $x = 2i + j - 3k$ and $y = 3i + 2j - 2k$. Respective. Find XY
5. Use reciprocal and square tables to evaluate, to 4 significant figures, The expression:
6. The figure below is a polygon in which $AB = CD = FA = 12\text{cm}$ $BC = EF = 4\text{cm}$ and $\angle BAF = \angle CDE = 120^\circ$. AD is a line of symmetry.

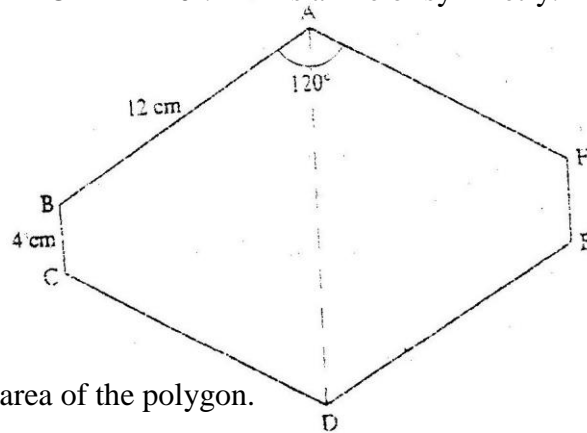

- Find the area of the polygon.
7. Akenyan tourist left Germany for Kenya through Switzerland. While in Switzerland he bought a watch worth 52 deutsche Marks. Find the value of the watch in:
 - (a) Swiss Francs.
 - (b) Kenya Shillings

Use the exchange rates below:

$$1 \text{ Swiss Franc} = 1.28 \text{ Deutsche Marks.} \quad (3\text{mks})$$

$$1 \text{ Swiss Franc} = 45.21 \text{ Kenya Shillings}$$

8. Solve the following inequalities and represent the solutions on a single number line:

$$3 - 2x < 5$$

$$4 - 3x \geq -8$$

(3mks)

9. The average rate of depreciation in value of a water pump is 9% per annum. After three complete years its like value was sh 150,700. Find its value at the start of the three – year period. (4mks)

10. The figure below shows a

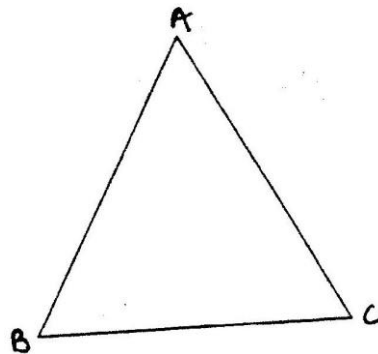

triangle ABC.

- (a) Using a ruler and a pair of compasses, determine a point D on the line BC such that $BD:DC = 1:2$.

(2mks)
 $AB = AC$.

b) Find the area of triangle ABD, given that (2mks)

11. The internal and external diameters of a circular ring are 6cm and 8cm respectively. Find the volume of the ring if its thickness is 2 millimeters. (3mks)

12. Chords XY and PQ of a circle intersect at a point M inside the circle. Given that $MX = 8\text{cm}$, $XY = 14\text{cm}$ and $MP = 4\text{cm}$, calculate the length of MQ. (2mks)

13. Given that $\sin a = \frac{1}{\sqrt{5}}$ where a is an acute angle find, without using

Mathematical tables: $\cos a$ in the form of $\frac{a}{b}$, where a and b are rational numbers at an $(90^\circ - a)$.

14. A quantity P is partly constant and partly varies inversely as a quantity q. Given that $P=10$ when $p = 20$ when $q = 1.25$, find the value of p when $q = 0.5$.

15. The table below shows the weight and price relatives of four items in a given period.

Item	weight	Price relative
------	--------	----------------

Maize meal	6	220
Meat	3	120
Sugar	4	180
Cooking fats	2	150

Compute the cost of living index for the given items.

16. Given the curve $y = 2x^3 + 1/2x^2 - 4x + 1$. Find the:

- Gradient of curve at $\{1, -1/2\}$
- Equation of the tangent to the curve at $\{1, -1/2\}$

17. A house is to be sold either on cash basis or through a loan. The cash price is sh.750,000. The loan conditions are as follows: there is to be down payment of 10% of the cash price and the rest of the money is to be paid through a loan at 10% per annum compound interest.

A customer decided to buy the house through a loan.

- (i) Calculate the amount of money loaned to the customer. (ii) The customer paid the loan in 3 years. Calculate the total amount paid for the house.
- Find how long the customer would have taken to fully pay for the house if she paid a total of sh 891,750. (8mks)

18. The figure below represents a right prism whose triangular faces are isosceles. The base and height of each triangular face are 12cm and 8cm respectively. The length of the prism is 20cm.

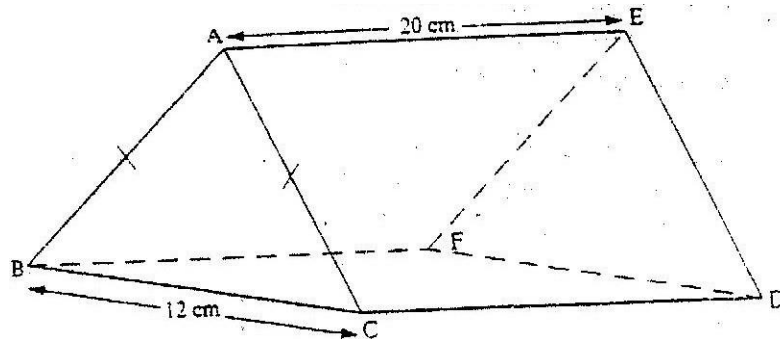

Calculate the:

- Angle CE
 - Angle between
 - The line CE and the plane BCDF
 - The plane EBC and the base BCDF
- b) During a certain motor rally it is predicted that the weather will be either dry (D) or wet (W). The probability that the weather will be dry is estimated to be $7/10$. The probability for a driver to complete (C) the rally during the dry weather is

estimated to be $\frac{5}{6}$. The probability for a driver to complete the rally during wet weather is estimated to be $\frac{1}{10}$.

Complete the probability tree diagram given below.

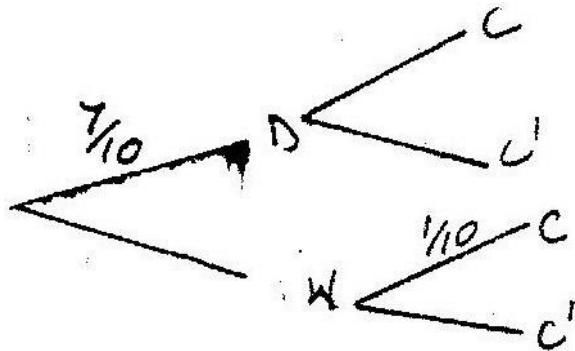

What is the probability that:-

- i) The driver completes the rally and the weather was wet and the driver did not complete the rally?

20. The diagram below shows a straight line intersecting the curve $y = (x-1)^2 + 4$ at the points P and Q. The line also cuts x-axis at (7,0) and y axis at (0,7) a) Find the equation of the straight line in the form $y = mx + c$.

b) Find the coordinates of P and Q.

c) Calculate the area of the shaded region. (8mks)

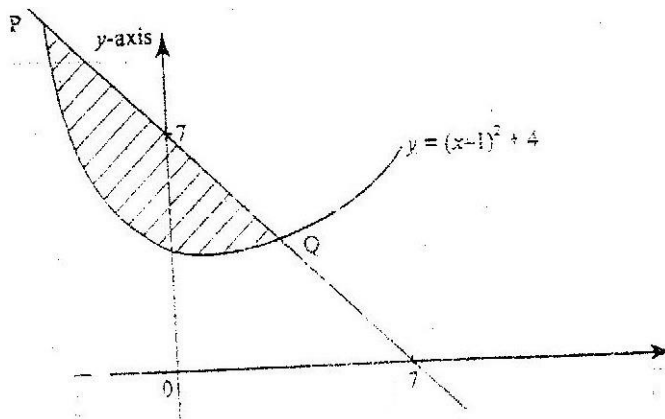

21. In this question use a ruler and a pair of compasses.

a) Line PQ drawn below is part of a triangle PQR. Construct the triangle PQR in which

a) $\angle QPR = 30^\circ$ and line $PR = 8\text{cm}$

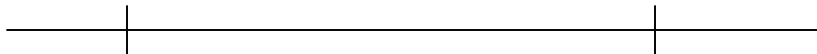

b) On the same diagram construct triangle PRS such that points S and Q are on the opposite sides of PR such that $PS = PQ$ and $QS = 8\text{cm}$

c) A point T is on the line passing through R and parallel to

QS.If $\angle QTS = 90^\circ$, locate possible positions of T and label them T^1 and T^2 , Measure the length of T^1T^2 .

22. A triangle T whose vertices are A (2,3) B(5,3) and C (4,1) is mapped onto triangle T^1 whose vertices are A^1 (-4,3) B^1 (-1,3) and C^1 (x,y) by a Transformation $M = \begin{pmatrix} a \\ b \\ c \end{pmatrix}$

d

- Find the: (i) Matrix M of the transformation
(ii) Coordinates of C_1
- b) Triangle T^2 is the image of triangle T^1 under a reflection in the line $y = x$. Find a single matrix that maps T and T^2 (8mks)
23. A minor sector of a circle of radius 28cm includes an angle of 135° at the center.
- a) (i) convert 1350 into radians. Hence of otherwise find the area of the sector. ii) Find the length of the minor arc.
- b) The sector is folded to form a right circular cone. Calculate the :
i) Radius of the cone
ii) Height of the cone. (Take the value of π to be $\frac{22}{7}$) (8mks)
24. Two quantities P and r are connected by the equation $p = kr^n$. The table of values of P and r is given below.

P	1.2	1.5	2.0	2.5	3.5	4.5
r	1.58	2.25	3.39	4.74	7.86	11.5

- a) State a liner equation connecting P and r.
b) Using the scale 2cm to represent 0.1 units on both axes, draw a suitable line graph on the grid provided. Hence estimate the values of K and n. (8mks)

MATHEMATICS PAPER 121/2

QUESTIONS K.C.S.E 2002

- Use logarithms to evaluate $\frac{(0.0056)^2}{1.38 \times 27.42}$
- Kipketer can cultivate a piece of land in 7 hours while Wanjiku can do the same work in 5 hours. Find the time they would take to cultivate the piece of land when working together.
- A triangular flower garden has an area of 28m². Two of its edges are 14 metres and 8 metres. Find the angle between the two edges.

4. Determine the inverse, T^{-1} of the matrix $T = \begin{pmatrix} 1 & 2 \\ 1 & -1 \end{pmatrix}$
5. A trader sells a bag of beans for shs. 2100 and that of maize at shs. 1200. He mixed beans and maize in the ratio 3:2. Find how much the trader should sell a bag of the mixture to realize the same profit.
6. The figure below represents a square based solid with a path marked on it.

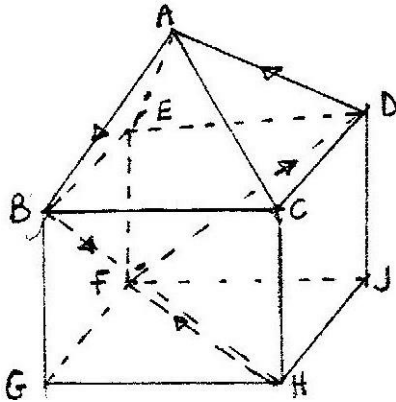

Sketch and label the net of the solid.

7. Solve for x in the equation $81^{2x} \times 27^x = 729$
 9^{4x}
8. The sides of a triangle were measured and recorded as 8cm, 10cm and 15cm. Calculate the percentage error in perimeter, correct to 2 decimal places.
9. a) Expand $(a - b)^6$
 b) Use the first three term of the expansion in a (a) to find the approximate value of $(1.98)^6$
10. The coordinates of points O,P,Q and R are (0,0)(3,4) (11,6) and (8,2) respectively. A point T is such that vectors OT,QP and QR satisfy the vector equation. $OT = QP + \frac{1}{2} QR$. Find the coordinates of T. 11. Simplify the expression $4x^2 - y^2$
 $2x^2 - 7xy + 3y^2$
12. Atieno and Kamau started a business by contributing sh.25000 and sh.20, 000 Respectively. At the end of the year, they realized a profit of shs. 81,000.The profit was allocated to development, dividends and reserves in the ratio 4:5:6 respectively. The dividends were the shared in the ratio of their contribution. Calculate the dividends paid to Atieno.
13. The diagram below shows a circle ABCDE. The line FEG is a tangent to the

circle at point E.

Line DE is parallel to CG, $\angle DEC = 28^\circ$ and $\angle AGE = 32^\circ$

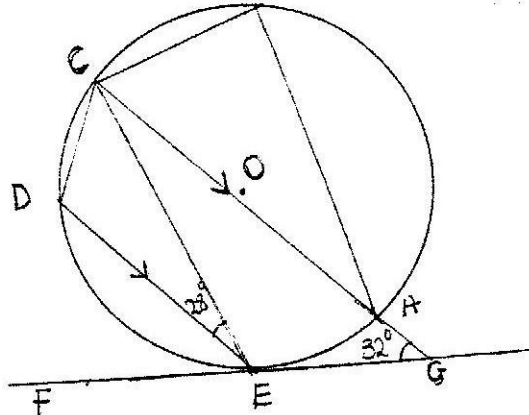

Calculate:

(a) $\angle AEG$

(b) $\angle ABC$

14. Each month, for 40 months, Amina deposited some money in a saving scheme. In the first month she deposited sh 500. Thereafter she increased her deposits by sh.50 every month.

Calculate the:

a) Last amount deposited by Amina

b) Total amount Amina had saved in the 40 months.

15. In the diagram below, ABCD is a trapezium with AB parallel to DC. The diagonals AC and BD intersect at E.

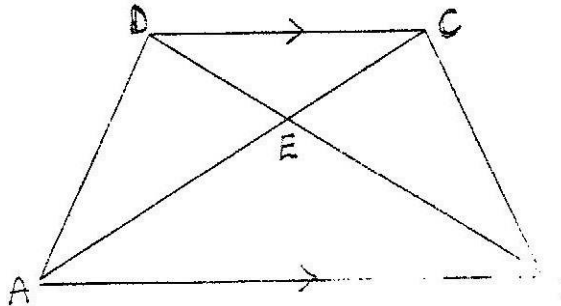

a) Giving reasons show that triangle ABE is similar to triangle CDE.

b) Giving that $AB = 3DC$, find the ratio of DB to EB.

16. The equation of a circle is given by $x^2 + 4x + y^2 - 5 = 0$. Find the radius and the center of the circle.

17. A bus travels from Nairobi to Kakamega and back. The average speed from Nairobi to Kakamega is 80km/hr while that from Kakamega to Nairobi is 50km/hr, the fuel consumption is 0.35 litres per kilometer and at 80km/h, the consumption is 0.3 litres per kilometer .Find

i) Total fuel consumption for the round trip

ii) Average fuel consumption per hour for the round trip.

18. The table below shows Kenyan tax rates in a certain year

Income (K£ per annum)	Tax rates (Sh. Per £)
1 -4,512	2
4513 -9024	3
9025 – 13536	4
13537 – 18048	5
18049 -22560	6
Over 22560	6.5

In that year Muhando earned a salary of Ksh.16510 per month. He was entitled to a monthly tax relief of Kshs 960.

Calculate:

- Muhandos annual salary in K£
- The monthly tax paid by muhando in Kshs.

19. The following distribution shows the masses to the nearest kilogram of 65 animals in a certain farm.

Mass Kg	26-30	31-35	36-40	41-45	46-50	51-55
frequency	9	13	20	15	6	2

- On the grid provided draw the cumulative frequency curve for the given information.
- Use the graph to find the:-
 - Median mass
 - Inter-quartile range
 - Percentage of animals whose mass is at least 42kg.

20. The figure VPQR below represents a model of a top of a tower. The horizontal base PQR is an equilateral triangle of side 9cm. The lengths of edges are $VP = VQ = VR = 20.5\text{cm}$. Point M is the mid point of PQ and $VM = 20\text{cm}$. Point N is on the base and vertically below V.

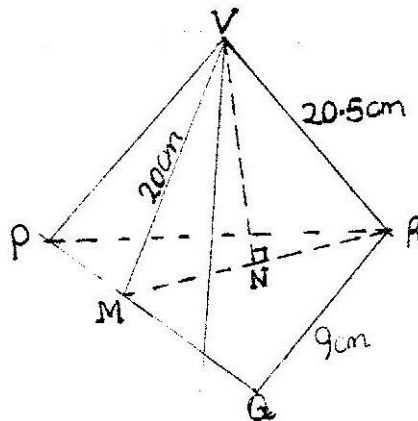

Calculate:

- Length of RM
 - Height of model
 - Volume of the model
- The model is made of material whose density is $2,700\text{ kg/m}^3$. Find the Mass of the model.

21. The table below shows the values of x and corresponding values of y for a given curve.

X	0	$\frac{\pi}{12}$	$\frac{\pi}{6}$	$\frac{\pi}{4}$	$\frac{\pi}{3}$	$\frac{5\pi}{12}$	$\frac{\pi}{2}$
y	0	0.26	0.48	0.65	0.76	0.82	0.84

- a) Use the trapezium rule with seven ordinates and the values in the table only to estimate the area enclosed by the curve, x – axis and the line $x = \frac{\pi}{2}$ to four decimal places. (Take $\pi = 3.142$)
- b) The exact value of the area enclosed by the curve is known to be 0.8940. Find the percentage error made when the trapezium rule is used. Give the answer correct to two decimal places.

22. Four points B, C, Q and D lie on the same plane. Point B is 42km due south – west of point Q. Point C is 50km on a bearing of S 60° E from Q. Point D is equidistant B, Q and C.

- a) Using the scale: 1cm represents 10km, construct a diagram showing the positions of B, C, Q and D.

Determines the: i) Distance between B and C
ii) Bearing of D from B.

23. a) Complete the table below, giving your values correct to 2 decimal places.

	0°	15°	30°	45°	60°	75°	90°	105°	120°	135°	150°	165°	180°
Tan θ°	0	0.27	0.58	1	1.73		a	3.73	1.73	-1		0.27	0
Sin θ°	0	0.5		1	0.87	0.5	0	-0.5		-1	0.87	-0.5	0

- b) Using the grid provided and the table in part (a) draw the graphs of $Y = \tan \theta$ and $y = \sin 2\theta$.
- c) Using your graphs, determine the range of values for which $\tan \theta > \sin 2\theta$ for $0^\circ \leq \theta \leq 90^\circ$.
24. The displacement s metre of a particle moving along straight line after t seconds is given by. $S = 3t + \frac{3}{2}t^2 - 2t^3$

- a) Find its initial acceleration

- b) Calculate: i) The time when the particle was momentarily at rest.
 ii) Its displacement by the time it comes to rest momentarily
 c) Calculate the maximum speed attained.

MARKING SCHEME 2003 MATHEMATICS PAPER 1

SECTION 1 (52 Marks)

1. Work out the following, giving the answer as a mixed number in its simplest form.

$$\frac{2}{5} \div \frac{1}{2} \text{ of } \frac{4}{9} - 1\frac{1}{10}$$

$$\frac{1}{8} - \frac{1}{6} \times \frac{3}{8}$$

2. Simplify the expression $\left(a + \frac{1}{b}\right)^2 - \left(a - \frac{1}{b}\right)^2$ (3mks)

3. Make c the subject of t formula: $T = x \sqrt{\frac{c}{c+d}}$ (3mks)

4. A water pump costs Kshs. 21600 when new. At the end of first year its value depreciates by 25%. The depreciation by the second year is 20% and thereafter the rate of the depreciation is 15% yearly. Calculate the exact value of the water pump at the end of the fourth year. (3mks)

5. In the figure below is the center of the circle ABCD and AOD in a straight line.

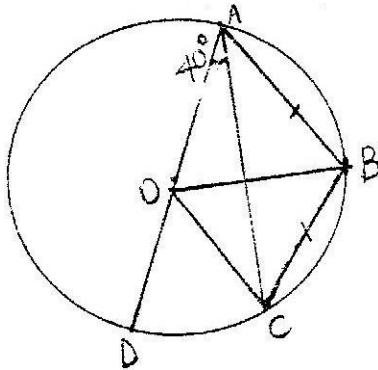

If $AB = BC$ and angle $DAC = 40^\circ$, Calculate angle BAC . (3mks)

6. Give that $x = 2i + j - 2k$, $y = -3i + 4j - k$ and $z = -5i + 3j + 2k$ and that $p = 3x - y + 2z$. Find the magnitude of vector p to 3 significant figures. (4mks)

7. Solve the equation $3 \tan^2 x - 4 \tan x - 4 = 0$ for $0^\circ \leq x < 180^\circ$ (4mks)

8. Using a ruler and a pair of compasses only.

a) Construct triangle ABC in which $BC = 8\text{cm}$, angle $ABC = 105^\circ$ and $\angle BAC = 45^\circ$

b) Drop a perpendicular from A to meet CB produced at p. Hence find the area of triangle ABC.

9. There are three cars A, B and C in a race. A is twice as likely to win as B while B is twice as likely to win as c. Find the probability that.

a) A wins the race

b) Either B or C win the race. (3mks)

10. The length of a solid prism is 10cm. Its cross section is an equilateral triangle of side 6cm.

Find the total surface area of the prism.

11. A wire of length 21cm is bent to form the shape down in the figure below, ABCD is a rectangle and AEB is an equilateral triangle. (2mks)

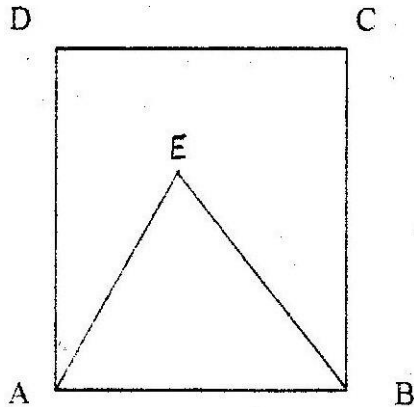

- If the length of AD of the rectangle is $1\frac{1}{2}$ times its width, calculate the width of the rectangle.
12. Two straight paths are perpendicular to each other at point p. One path meets a straight road at point A while the other meets the same road at B. Given that PA is 50 metres while PB is 60 metres. Calculate the obtuse angle made by path PB and the road.
13. The length of a hollow cylindrical pipe is 6metres. Its external diameter is 11cm and has a thickness of 1cm. Calculate the volume in cm^3 of the material used to make the pipe.
Take π as 3.142.
14. a) Write an expression in terms of x and y for the total value of a two digit number having x as the tens digit and y as the units digit.
b) The number in (a) above is such that three times the sum of its digits is less than the value of the number by 8. When the digits are reversed the value of the number increases by 9. Find the number.
15. Three points O, A and B are on the same horizontal ground. Point A is 80 metres to the north of O. Point B is located 70 metres on a bearing of 060° from A. A vertical mast stands at point B.
The angle of elevation of the top of the mast from o is 20° .

- Calculate: a) The distance of B from O. (2mks)
 b) The height of the mast in metres (2mks)

16. The velocity V ms⁻¹ of particle in motion is given by $V = 3t^2 - t + 4$, where t is time in seconds.

Calculate the distance traveled by the particle between the time $t=1$ second and $t=5$ seconds.

17. A rectangular tank whose internal dimensions are 1.7m by 1.4m by 2.2m is three-quarters full of milk.

- a) Calculate the volume of milk in the tank in cubic metres.
 b) Pyramid on an equilateral triangular base of side 16cm. The height of each packet is 1.6cm. Full packets obtained are sold at sh.25 per packet.
 i) The volume of milk in cubic centimeters, contained in each packet to 2 significant figures
 ii) The exact amount that will be realized from the sale of all the packets of milk.

18. The mass of 40 babies in a certain clinic were recorded as follows:

<u>Mass in Kg</u>	<u>No. of babies.</u>
1.0 – 1.9	6
2.0 – 2.9	14
3.0 -3.9	10
4.0 – 4.9	7
5.0 – 5.9	2
6.0 – 6.9	1

Calculate

- (a) The inter – quartile range of the data.
 (b) The standard deviation of the data using 3.45 as the assumed mean.

19. The figure below shows two circles with centers at X and Y. The circles touch each other at point Q.

each of radius 7cm,
 touch each other at

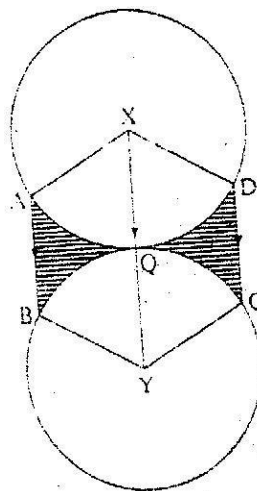

Given that $AXD = BYC = 1200$ and lines AB , XQY and DC are parallel, calculate the area of:

- Minor sector $XAQD$ (Take $\pi^{22/7}$)
- The shaded regions.

20. The diagram below is a sketch of the curve $y = x^2 + 5$.

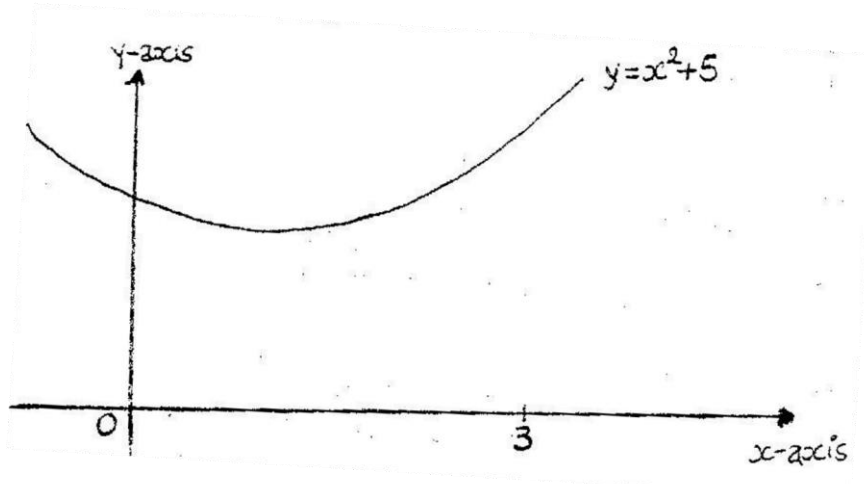

- Use the mid-ordinate rule, with six strips to estimate the area enclosed by the curve, the x -axis and the y -axis and line $x = 3$. (4mks)
 - Calculate the same area using the integration method. (2mks)
- Assuming the area calculated in (a) (ii) _____ calculate the percentage error made when the mid-ordinate rule is used.

21. In the figure below, vector $OP = p$ and $OR = r$. Vector $OS = 2r$ and $OQ = \frac{3}{2}p$.

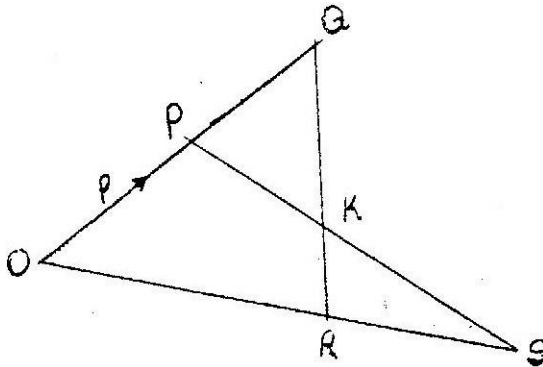

- Express in terms of p and r (i) QR and (ii) PS
- The lines QR and PS intersect at K such that $QK = m QR$ and $PK = n PS$, where m and n are scalars. Find two distinct expressions for OK in terms of p, r, m

and n. Hence find the values of m and n. (5mks)

c) State the ratio PK:KS

22. Complete the table below, for function $y = 2x^2 + 4x - 3$

X	-4	-3	-2	-1	0	1	2
$2x^2$	32		8	2	0	2	
$4x - 3$			-11		-3		5
y			-3			3	13

(b) On the grid provided, draw the graph of the function $y = 2x^2 + 4x - 3$ for $-4 \leq x \leq 2$ and use the graph to estimate the roots of the equation $2x^2 + 4x - 3 = 0$ to 1 decimal place. (2mks)

c) In order to solve graphically the equation $2x^2 + x - 5 = 0$, a straight line must be drawn to intersect the curve $y = 2x^2 + 4x - 3$. Determine the equation of this straight line, draw the straight line hence obtain the roots.

23. A businessman obtained a loan of sh.450,000 from a bank to buy a matatu valued at the same amount. The bank charges interest at 24% per annum compounded equation. $2x^2 + x - 5 = 0$ to 1 decimal place.

- Calculate the total amount of money the businessman paid to clear the loan in $1 - \frac{1}{2}$ years.
- The average income realized from the matatu per day was sh.1500. The matatu worked for 3 years at an average of 280 days year. Calculate the total income from the matatu.
- During the three years, the value of the matatu depreciated at the rate of 16% per annum. If the businessman sold the matatu at its new value, calculate the total profit he realized by the end of three years. (3mks)

24. Two towns A and B lie on the same latitude in the northern hemisphere. When its 8am at A, the time at B is 11.00am.

- Given that the longitude of A is 150 E find the longitude of B. (2mks)
- A plane leaves A for B and takes $3\frac{1}{2}$ hours to arrive at B traveling along a parallel of latitude at 850km/h. Find:
 - The radius of the circle of latitude on which towns A and B lie. (3mks)
 - The latitude of the two towns (take radius of the earth to be 6371km) (3mks)

MATHEMATICS PAPER 2 QUESTIONS K.C.S.E 2003

1. Use logarithm tables to evaluate $\frac{2347}{x} \times 0.4666$

2. A shirt whose marked price in shs.800 is sold to a customer after allowing him a discount of 13%. If the trader makes a profit of 20%, find how much the trader paid for the shirt.
3. The table below shows the number of goals scored by a football team in 20 matches

Goals scored	0	1	2	3	4	5
Number of matches	5	6	4	3	1	1

Find:

- a) The mode (1mk)
- b) The mean number of goals (2mks)
4. A straight line passes through points A(-3,8) and B(3, -4). Find the equation of the straight line through (3,4) and parallel to AB. Give the answer in the form $y = mx + c$, and m and c are constants. (3mks)
5. Solve the equation $10^{\log(6x-2)} - 1 = 10^{\log(x-3)}$ (3mks)
6. A train moving at an average speed of 72km/h takes 15 seconds to completely cross a bridge that is 80 metres long.
- a) Express 72km/h in metres per second (1mk)
- b) Find the length of the train in metres (2mks)

7. In the figure A'B'C' is the image of triangle ABC under a

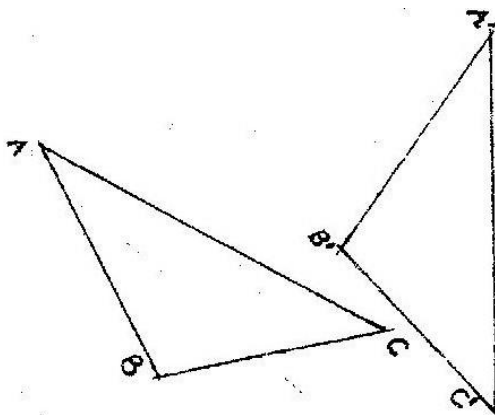

below, triangle image of triangle rotation, centre O.

By construction, find the label the centre O of the rotation. Hence, determine the angle of the rotation.

8. Find the coordinates of the turning point of the curve whose equation is $y = 6 + 2x - 4x^2$

9. The surface area of a solid hemisphere is radius _____ the volume of the solid, leaving your answer in terms of n.
10. Given that $a = \sqrt[3]{1}$ and $b = \sqrt[3]{13}$, express $\sqrt[3]{3-6\sqrt{39}}$ in terms of a and b and simplify the answer.
11. a) Expand and simplify the binomial expression $(2 - x)^6$ (2mks) b) Use the expansion up to the term in x^2 to estimate 1.99^6 (2mks)
12. A mixed school can accommodate a maximum of 440 students. The number of girls must be at least 120 while the number of boys must exceed 150. Taking x to represent the number of boys and y the number of girls, write down all the inequalities representing the information above.
13. Machine A can do a piece of work in 6 hours while machine B can do the same work in 9 hours. Machine A was set to do the piece of work but after $3\frac{1}{2}$ hours, it broke down and machine B did the rest of the work. Find how long machine B took to do the rest of the work (3mks)
14. Three business partners Atieno, Wambui and Mueni contributed sh 50,000, sh 40,000 and sh 25,000 respectively to start a business. After some time, they realized a profit, which they decided to share in the ratio of their contributions. If Mueni's share was sh 10,000, by how much was Atieno's share more than Wambui's? (3mks)
15. A colony of insects was found to have 250 insects at the beginning. Thereafter the number of insects doubled every 2 days. Find how many insects there were after 16 days. (3mks)
16. A distance s metres of an object varies with time t seconds and partly with the square root of the time. Give that $s = 14$ when $t = 9$, write an equation connecting s and t .

SECTION ii (48 MARKS)

Answer any six questions in this section.

17. Given the simultaneous equations
- $$5x + y = 19$$
- $$-x + 3y = 9$$
- a) Write the equations in matrix form. Hence solve the simultaneous equations.

(5mks)

- b) Find the distance of the point of intersection for the line $5x + y = 19$ and $-x + 3y = 9$ from the point $(11, -2)$ (3mks)

18. A dealer has three grades of coffee X, Y and Z. Grade X costs sh 140 per kg, grade Y costs sh 160 per kg grade Z costs sh.256 per kg.

- a) The dealer mixes grades X and Y in the ratio 5:3 to make a brand of coffee which sells at sh 180 per kg.
b) The dealer makes a new brand by mixing the three grades of coffee. In the ratios $X:Y = 5:3$ and $Y:Z = 2:5$

Determine:

- i) The ratio $X: Y: Z$ in its simplest form (2mks)
ii) The selling price of the new brand of he has to make a 30% profit. (3mks)

19. A ship leaves port P for port R through port Q. Q is 200 km on a bearing of 220° from P. R is 420 km on the bearing of 140° from Q.

- a) Using the scale 1:4,000,000, draw a diagram, showing the relative positions of the three ports P, Q, and R.
b) By further drawing on the same diagram, determine how far R is to the east of P Distance = 3.5×40
c) If the ship has sailed directly from P to R at an average speed of 40 knots, find how long it would have taken to arrive at R. (Take 1 nautical mile = 1.853 km)

20. Omondi makes two types of shoes: A and B. He takes 3 hours to make one pair of type A and 4 hours to make one pair of type B. He works for a maximum of 120 hours to x pairs of type A and Y pairs of type B. It costs him sh 400 to make a pair of type A and sh 150 to make a pair of type B.

His total cost does not exceed sh 9000. He must make 8 pairs of type A and more than 12 pairs of type B.

21. a) i) Find the coordinates of the stationary points on the curve $y = x^2 - 3x + 2$ (2mks)
ii) For each stationary point determine whether it is minimum or maximum.
b) In the space provided below, sketch the graph of the Function $y = x^2 - 3x + 2$ (2mks)

22. The line PQ below is 8cm long and L is its midpoint

- a) i) Draw the locus of point R above line PQ such that the area of triangle PQR is 12cm^2 .

ii) Given that point R is equidistant from P and Q, show the position of point R..

b) Draw all the possible loci of a point T such that $\angle RQL = \angle RTL$. (4mks)

23. a) Complete the table below, giving your values correct to 2 decimal places.

X	0	15	30	45	60	75	90	105	120	135	150	165	180
Cos x	1	0.77	0.87	0.71	0.15	0.24	0	-0.26	-0.5	-0.17	0.5	0.87	1
Sin (x + 30)	0.5	0.17	0.87	0.97	0.10	0.97	0.87	0.71	0.5	-0.26	0	-0.26	-0.5

b) Using the grid provided draw, on the same axes, the graph of $y = \cos 2x$ and $y = \sin (x + 30^\circ)$ for $0^\circ < x < 180^\circ$

Take the scale: 1cm for 15° on the x axis

4cm for 1 unit on the y- axis. (4mks)

c) Find the periods of the curve $Y = \text{axis}$ (1mks)

d) Using the graphs in part (b) above, estimate the solutions to the equation

$\sin (x + 30^\circ) = \cos 2x$ (4mks)

24. The figure below represents a right pyramid with vertex V and a rectangular base PQRS.

$VP = VQ = VR = VS = 18\text{cm}$ and $QR = 16\text{cm}$ and $QR = 12\text{cm}$. M and O are the midpoints of QR and PR respectively.

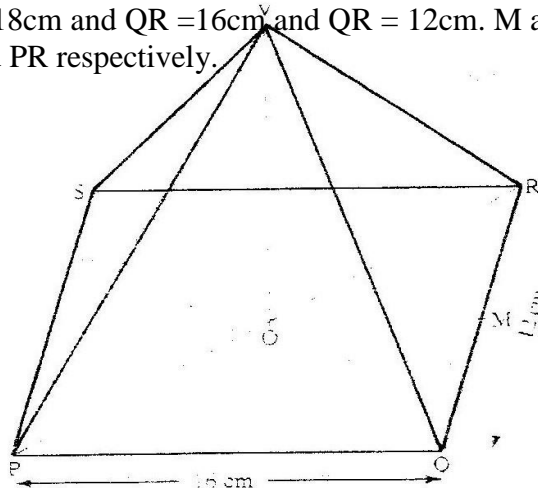

Find:

- The length of the projection of line VP on the plane PQRS (2mks)
- The size of the angle between line VP and the plane PQRS. (2mks)
- The size of the angle between the planes VQR and PQRS. (2mks)

MATHEMATICS PAPER 121/1 K.C.S.E 2004

SECTION 1(52 MARKS)

Answer all the questions in this section

1. Without using logarithm tables evaluate

$$\frac{0.015 + 0.45 \div 1.5}{4.9 \times 0.2 + 0.07}$$

Giving the answer in decimal form.

2. The size of an interior angle of a regular polygon is 156° . Find the number of sides of the polygon.

3. Simplify the expression $2a^2 - 3ab - 2b^2$

$$\frac{\quad}{4a^2 - b^2}$$

4. Given that $OA = 3i - 2j + k$ and $OB = 4i + j - 3k$. Find the distance between points A and B to 2 decimal places.

5. The velocity V ms, of a moving body at time t seconds is given by $V = 5t^2 - 12t + 7$

6. Point C divided the line AB given below externally in the ratio 5:2

B

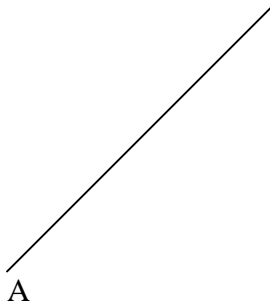

By construction, determine the position of point c

7. In the year 2003, the population of a certain district was 1.8 million. Thirty per cent of the population was in the age group 15 – 40 years. In the same year, 120,000 people in the district visited the Voluntary Counseling and Testing (VCT) centre for an HIV test.

If a person was selected at random from the district in this year. Find the probability that the person visited a VCT centre and was in the age group 15 – 60 years.

8. Use tables of reciprocals only to work out

$$\frac{3}{0.6735} + \frac{13}{0.156}$$

9. Give that x_0 is an angle in the first quadrant such that $8 \sin 2x + 2 \cos X - 5 = 0$

Find:

- a) $\cos x$
b) $\tan x$

10. Omolo bought a new car for ksh. 800,000. After 5 years, he sold it through a second- hand car dealer. The dealer charged a commission of 4% for the sale of the car. If Omolo received Ksh.480, 000, calculate the annual rate of depreciation of the car.

11. The table below shows some values of the function $y = x^2 + 3$

X	0	1/2	1	1 1/2	2	2 1/2	3	3 1/2	4	4 1/2	5	5 1/2	6
y	3		4	5 1/4	7		12	15 1/4	19		28		39

- a) Complete the table
b) Use the mid – ordinate rule with six ordinates to estimate the area bounded by $y = x \div 3$, the y – axis, the x – axis and the line $x = 6$

12. In the figure below PQRS is a trapezium with SR parallel to PQ. $SR = 5\text{cm}$, $RQ = 4\text{cm}$, $QS = 8\text{cm}$ and $PQ = 10\text{cm}$.

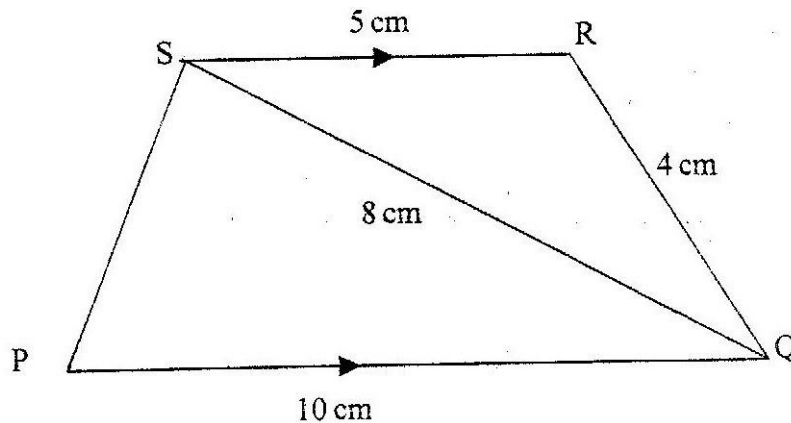

Calculate:

- a) The size of angle QSR
b) The area of triangle PQS

13. The figure below represents a hexagon of side 5cm.

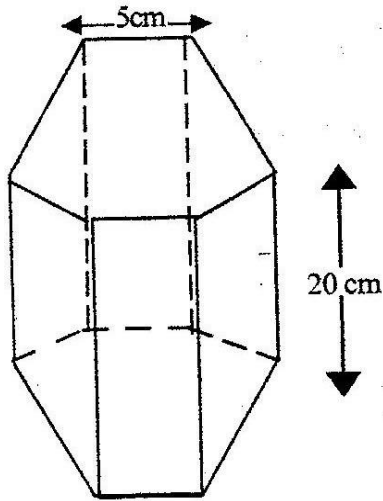

Find the volume of the prism.

14. The figure below shows a circle, centre, O of radius 7cm. TP and TQ are tangents to the circle at points P and Q respectively. OT = 25cm.

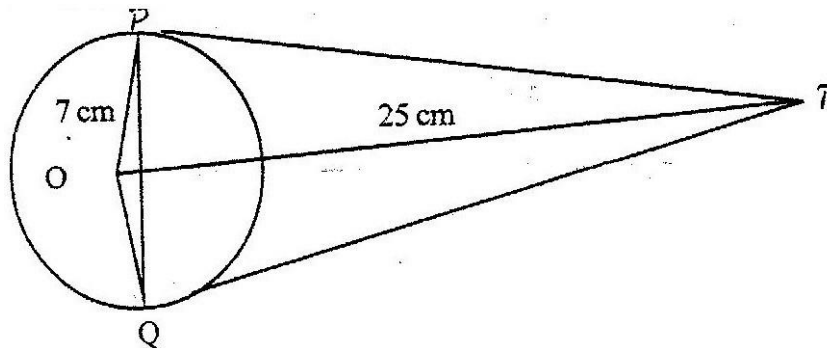

Calculate the length of the chord PQ

15. The figure below is a triangle XYZ. Using a pair of compasses and a ruler only, construct an inscribed circle such that the centre of the circle and the point x are sides of line Yz.

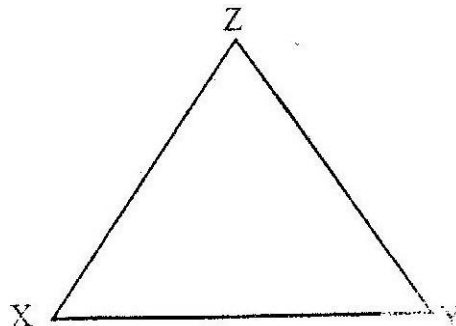

16. P(5,) and Q (-1,2) are points on a straight line. Find the equation of the perpendicular bisector of PQ: giving the answer in the form $y = mx+c$.

SECTION II (48 MARKS)

17. The table below shows monthly income tax rates for the year 2003.

Monthly taxable income in Ksh.	Tax rates(Percentage)
1-9860	10%
9681 – 18800	15%
27921 – 37040	20%
37041 and above	25%
	30%

In the year 2003.Ole Sanguya’s monthly earnings were as follows:-

Basic salary Ksh 20600
House allowance ksh 12000
Medical allowance Ksh 2880 Transport
allowance Ksh 340.

Ole Sanguya was entitled to a monthly tax relief of Ksh 1056.

Calculate:

- a) His monthly taxable income
 - b) The monthly tax paid by Ole Sanguya.
18. The equation of a curve is given $y = x^2 + 4x^2 - 2$
- a) Determine the coordinates of the turning points of the curve, correct to 1 decimal place.
 - b) Use the equation of the curve to complete the table below.

X	-4	-3	-2	-1	0	1
y	-2		6	1		

- c)
 - i) On the grid provided, use the solutions in part (a) and the values in the table in part (b) to draw the curve for $-4 < x < 1$.
 - ii) Use the graph to solve the equation $x^3 + 4x^2 - 2 = 0$

19. The figure below represents a model of a solid structure in the shape of a frustum of a cone with hemispherical top. The diameter of the hemispherical part is 70cm and is equal to the diameter of the top of the frustum. The frustum has a base diameter of 28cm and slant height of 60cm.

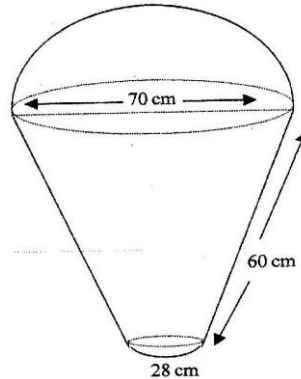

Calculate

- The area of hemispherical surface.
 - The total surface area of the model.
20. The simultaneous equations below, are satisfied when $x = 1$ and $y = p$
- $$-3x + 4y = 5 \quad qx^2$$
- $$-5xy + y^2 = 0$$
- Find the values of P and Q.
 - Using the value of Q obtained in (a) above, find the other values of x and y which also satisfy the given simultaneous equations.
21. a) If A,B and C are the points P and Q are p and q respectively is another point with position vector $r = 3q - \frac{1}{2}p$.
Express in terms of p and q.
- PR R are collinear.
 - RQ hence show that P,Q and R are collinear.
 - Determine the ratio PQ:QR.
22. In the figure below, K M and N are points on the circumference of a circle centre O. The points K, O, M and p are on a straight line. PN is a tangent to the circle at N. Angle KOL = 130° and angle MKN = 40°

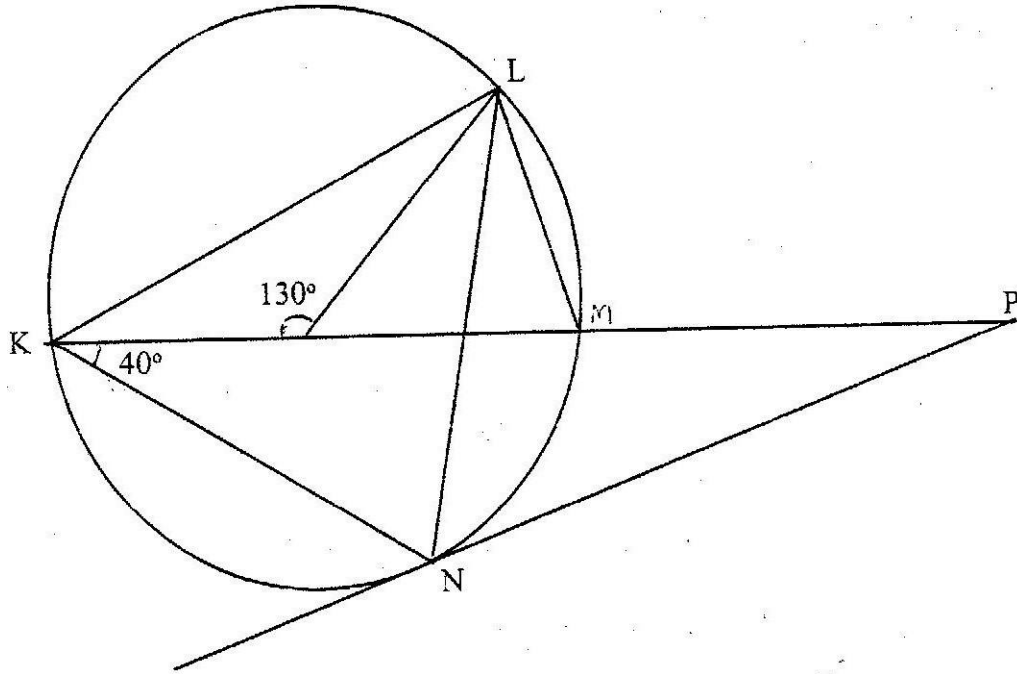

Find the values of the following angles, stating the reasons in each case:

- a) $\angle MLN$
- b) $\angle OLN$
- c) $\angle LNP$
- d) $\angle MPN$

23. A triangular plot ABC is such that the length of the side AB is two thirds that of BC. The ratio of the lengths $AB:AC = 4:9$ and the angle at B is obtuse.

- a) The length of the side BC
- b) i) The area of the plot
- iii) The size of $\angle ABC$

24. A man who can swim at 5km/h in still water swims towards the east to cross a river. If the river flows from north to south at the rate of 3km/h

- a) Calculate:
 - i) The resultant speed
 - ii) The drift
- b) If the width of the river is 30m, find the time taken, in seconds, for the man to cross the river.

MATHEMATICS PAPER 121/2 K.C.S.E 2004
QUESTIONS
SECTION 1 (52 marks)

Answer all the questions in this section

1. Use logarithms to evaluate

$$\sqrt[34.33]{5.25 \times 0.042}$$

2. The marked price of a car in a dealer's shop was Kshs 400,000. Wekesa bought the car at 8% discount. The dealer still made a profit of 15%. Calculate the amount of money the dealer had paid for the car.
3. Find the number of terms of the series $2 + 6 + 10 + 14 + 18 + \dots$ that will give a sum of 800.
4. Two trains T1 and T2 traveling in the opposite directions, on parallel tracks are just beginning to pass one another. Train T1 is 72 m long and traveling at 108 km/h. T2 is 78 m long and is traveling at 72 km/h.

Find the time, in seconds, the two trains take to completely pass one another

5. Evaluate without using mathematical tables, the expression

$$2 \log_{10} 5 - \frac{1}{2} \log_{10} 16 + 2 \log_{10} 40$$

6. A student obtained the following marks in four tests during a school term: 60%, 75%, 48% and 66%. The tests were weighted as follows: 2, 1, 4 and 3 respectively. Calculate the student's weighted mean mark of the tests

7. Use matrices to solve the simultaneous equations

$$4x + 3y = 18$$

$$5x - 2y = 11$$

8. (a) Expand $(1 + x)^5$
(b) Use the first three terms of the expansion in (a) to find the approximate value of $(0.98)^5$

9. Make b the subject $a = \sqrt{bd}$

$$\sqrt{b^2 - d}$$

10. A group of 5 people can do a piece of work in 6 hours. Calculate the time a group of people. Working at half the rate of the first group would take to complete the same work.
11. In the figure below ABCDE is a cross- section of a solid. The solid has uniform cross- section. Given that BG is a base edge of the solid, complete the sketch, showing the hidden edges with broken lines.

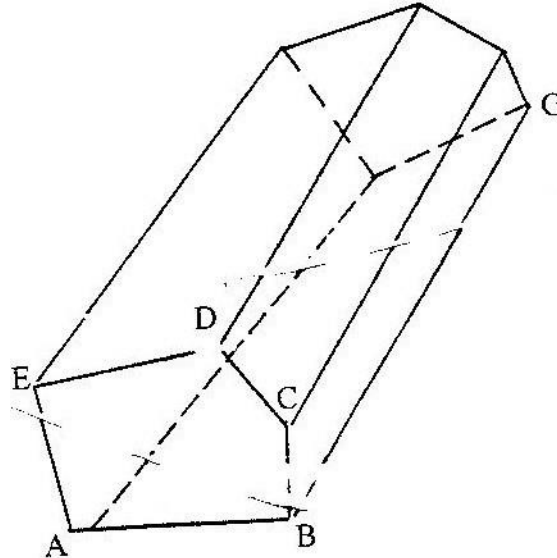

12. An industrialist has 450 litres of a chemical which is 70% pure. He mixes it with a chemical of the same type but 90% pure so as to obtain a mixture which is 75% pure.

Find the amount of the 90% pure chemical used

13. The gradient function of a curve is given $\frac{dy}{dx} = 3x^2 - 8x + 2$. If the curve passes through the point, (0, 2), find its equation.

14. In this questions, mathematical tables should not be used At Kenya bank buys sells foreign currencies as shown below:

	Buying (Kenya Shillings)	Selling (Kenya Shillings)
1 Euro	84.15	84.26
100 Japanese yen	65.37	65.45

A Japanese traveling from France arrives in Kenya with 5000 Euros, he converts all the 5000 Euros to Kenya Shillings at the bank.

Calculate the amount in Japanese yen, than he receives.

15. Form the three inequalities that satisfy the given region R.

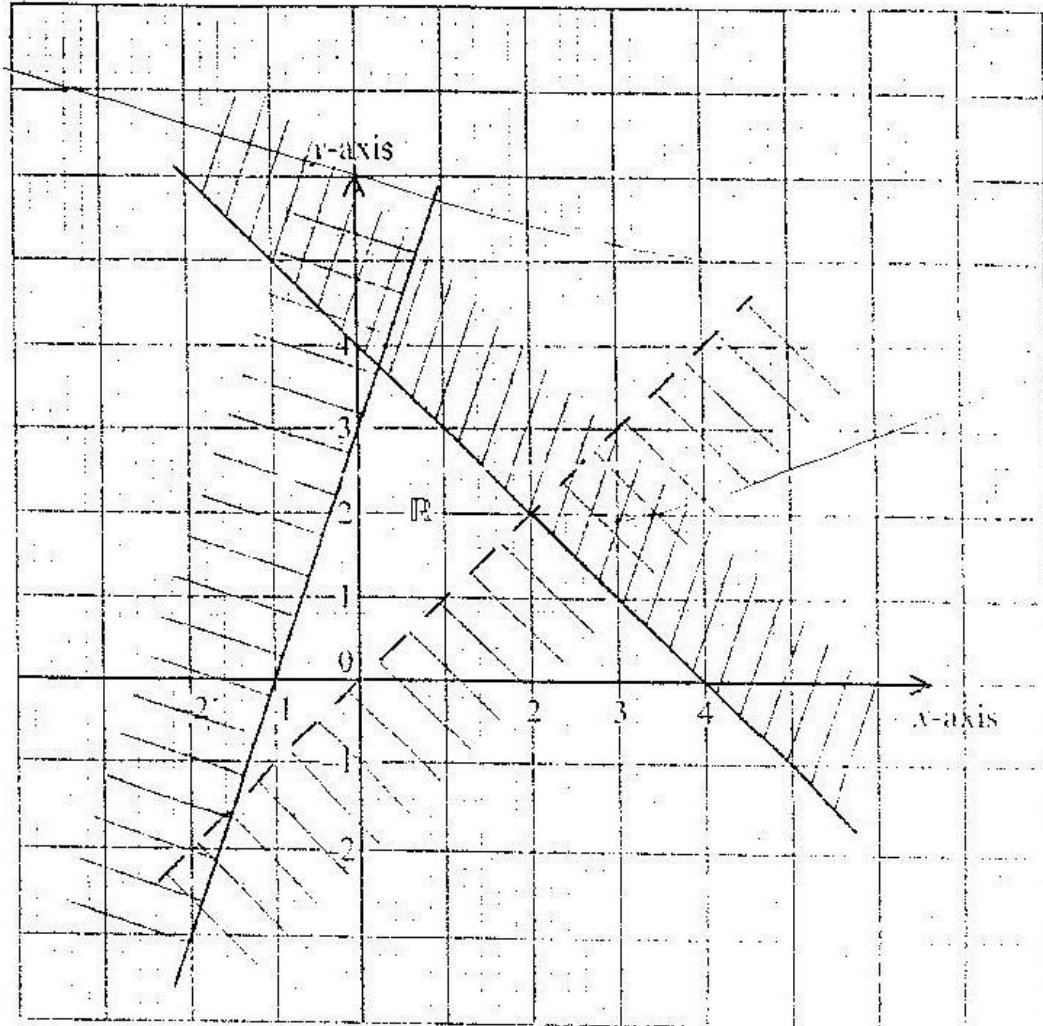

16. Without using mathematical tables, simplify

$$\sqrt{\frac{2}{3-7}} - \frac{2}{\sqrt{3+7}}, \text{ in the form } a + b \sqrt{c} \quad \text{SECTION II}$$

(48 Marks)

Answer any six questions from this section

17. Farmer has two tractors A and B. The tractors, working together can plough a farm in $2\frac{1}{2}$ h. One day, the tractors started to plough the farm together. After 1 h

10 min tractor B broke down but A continued alone and completed the job after a further 4 h.

Find:

- (a) The fraction of the job done by the tractors, working together for one hour
- (b) The fraction of the job done by tractor A and B broke down
- (c) The time each tractor working alone would have taken to plough the farm.

18. The table below shows the ages in years of 60 people who attended a conference.

Age in years	30 – 39	40- 49	50- 59	60- 69	70-79
Number of people	10	12	18	17	3

Calculate

- (a) The inter-quartile range of the data
- (b) The percentage of the people in the conference whose ages were 54.5 years and below.

19. For electricity posts, A,B,C, and D stand on a level ground such that B is 21 m on a bearing of 060° from A, C, is 15 m to the south of B and D is 12 m on a bearing of 140° from A.

- (a) (i) Using scale of 1 cm of 1 cm to represent 3 metres, draw a diagram to show the relative positions of the posts
- (ii) Find the distances and the bearing of C from D
- (b) The height of the post at A is 8.4m. On a separate scale drawing, mark and determine the angle of depression of the foot of the post at C from the top of the post at A.

20. (a) Given that the matrix $A = \begin{pmatrix} 2 & 3 \\ 3 & 4 \end{pmatrix}$ Find A^{-1} the inverse of A

- (b) Kimtai bought 200 bags of sugar and 300 bags of rice for a total of Kshs. 850,000. Buyu bought 90 bags of sugar and 120 bags of rice for a total of Kshs. 360,000. If the price of a bag of sugar is Kshs x and that of rice is Kshs. Y,
 - (i) Form two equations to represent the information above
 - (ii) Use the matrix A^{-1} to find the prices of one bag of each item.

(c) Kali bought 225 bags of sugar and 360 bags of rice. He was given a total

If the discount on the price of a bag of rice was 2%, calculate the percentage discount on the price of a bag of sugar.

21. Triangle ABC is the image of triangle PQR under the transformation $M = \begin{pmatrix} 2 & 4 \\ 0 & 2 \end{pmatrix}$

Where P, Q and P map onto A, B, and C respectively.

(a) Given the points P(5, -1), Q(6,-1) and R (4, -0.5), draw the triangle ABC on the grid provided below.

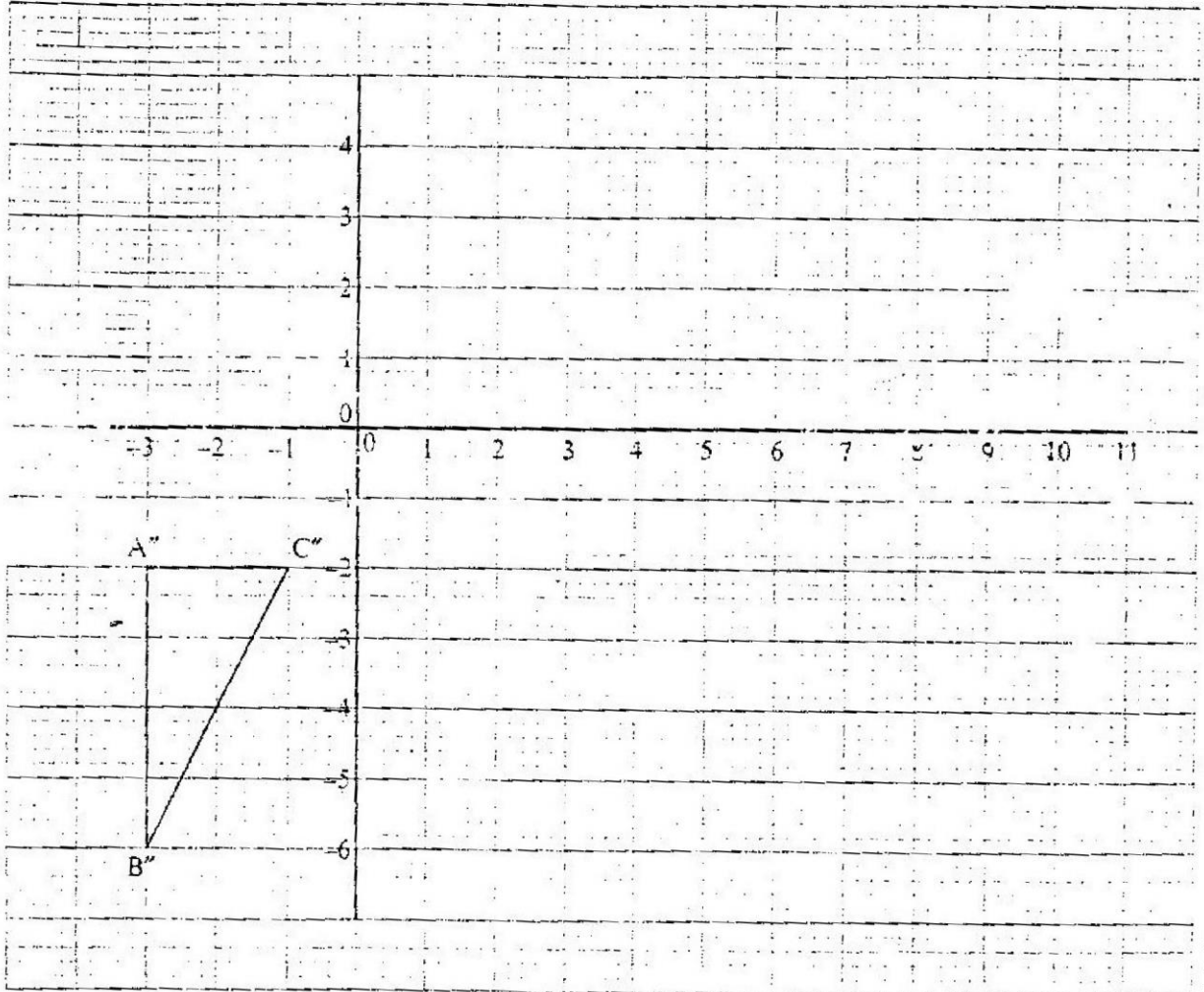

(b) Triangle ABC in part (a) above is to be enlarged scale factor 2 with centre at (11, -6) to map onto A'B'C'.

Construct and label triangle A'B'C' on the grid above.

discount of Kshs. 33, 300.

(c) By construction find the coordinates of the centre and the angle of rotation which can be used to rotate triangle A'B'C' onto triangle A''B''C'', shown on the grid above.

22. A particle moves in a straight line. It passes through point O at $t = 0$ with velocity $v = 5 \text{ m/s}$. The acceleration $a \text{ m/s}^2$ of the particle at time t seconds after passing through O is given by $a = 6t + 4$
- (a) Express the velocity v of the particle at time t seconds in terms of t
- (b) Calculate
- The velocity of the particle when $t = 3$
 - The distance covered by the particle between $t = 2$ and $t = 4$
23. Three quantities P, Q and R are such that P varies directly as the square of Q and inversely as the square root of R.
- (a) Given that $P = 20$ when $Q = 5$ and $R = 9$, find P when Q and $R = 25$
- (b) If Q increases by 20% and decreases by 36%, find the percentage increase in P.
24. The figure below shows a model of a roof with a rectangular base PQRS $PQ = 32 \text{ cm}$ and $QR = 14 \text{ cm}$. The ridge XY = 12 cm and is centrally placed. The faces PSX and QRY are equilateral triangles M is the midpoint of QR.

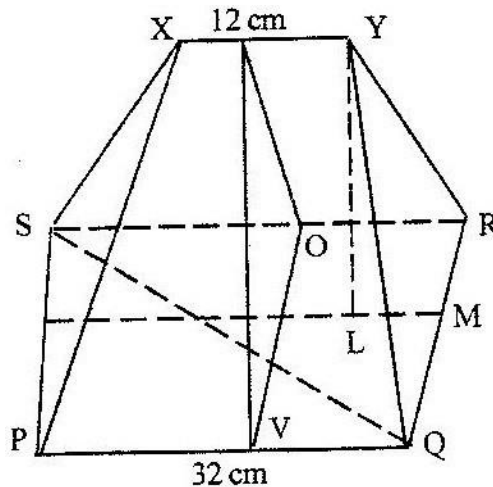

Calculate

- (a) (i) the length of YM
- (ii) The height of Y above the base PQRS
- (b) The angle between the planes RSXY and PQRS
- (c) The acute angle between the lines XY and QS

121/ 1 MATHEMATICS 2005

PAPER 1

SECTION 1 (52 Marks)

Answer all the question in this section

1. Evaluate

$$\frac{3}{4} + 1\frac{5}{7} \div \text{of } 2\frac{1}{3}$$

$$(1\frac{3}{7} - \frac{5}{8} \times \frac{2}{3})$$

(3 marks)

2. Express the numbers 1470 and 7056, each as a product of its prime factors
 Hence evaluate

$$\sqrt[1470^2]{7056}$$
 Leaving the answer in prime form
 (3 marks)

3. The area of a rhombus is 60cm^2 . Given that one of its diagonals is 15 cm long, calculate the perimeter of the rhombus (3 marks)

4. Simplify the expression

$$\frac{9t^2 - 25a^2}{6t^2 + 19at + 15a^2}$$

(3 marks)

5. The size of each interior angle of a regular polygon is five times the size of the exterior angle. Find the number of sides of the polygon. (3 marks)

6. A point R divides a line PQ internally in the ration 3:4. Another point S, divides the line PR externally in the ration 5:2. Given that PQ = 8cm, calculate the length of RS, correct to 2 decimal places. (3 marks)

7. Given that $\sin(90 - x)^\circ = 0.8$, where x is an acute angle, find without using mathematical tables the value of $\tan x^\circ$.

8. Two teachers are chosen randomly from a staff consisting 3 women and 2 men to attend a HIV/AIDs seminar. Calculate the probability that the two teachers chosen are:
 - (a) Of the same sex
 - (b) Of opposite sex

9. In this question Mathematical Tables should not be used
 The base and perpendicular height of a triangle measured to the nearest centimeter are 6 cm and 4 cm respectively.
 Find
 - (a) The absolute error in calculating the area of the triangle (2marks)
 - (b) The percentage error in the area, giving the answer to 1 decimal place (2mks)

10. Make P the subject of the formula

$$P^2 = (P - q) (P - r)$$

(3 marks)

11. On the diagram below, the line whose equation is $7y - 3x + 30 = 0$ passes through points A and B. Point A is on the x-axis while point B is equidistant from x- and y axes.

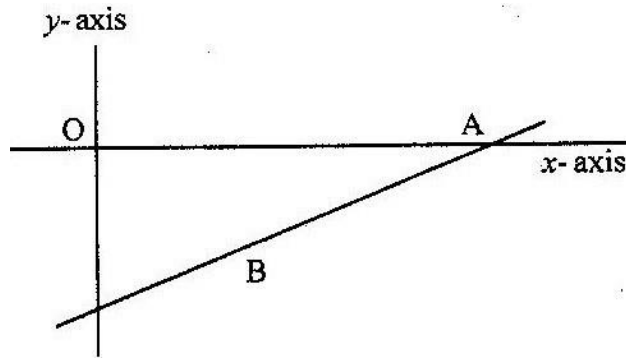

Calculate the co-ordinates of the points A and B

(3mks)

12. A cylindrical piece of wood of radius 4.2 cm and length 150 cm is cut lengthwise into two equal pieces.

Calculate the surface area of one piece

(Take π as $22/7$)

(4mks)

13. Point T is the midpoint of a straight line AB. Given the position vectors of A and T are $i - j + k$ and $2i + 1\frac{1}{2}k$ respectively, find the position vector of B in terms of i, j and k .

(3 marks)

14. The figure below shows a quadrilateral ABCD in which $AB = 8$ cm, $DC = 12$ cm,

$\angle BAD = 45^\circ$

$\angle CBD = 90^\circ$

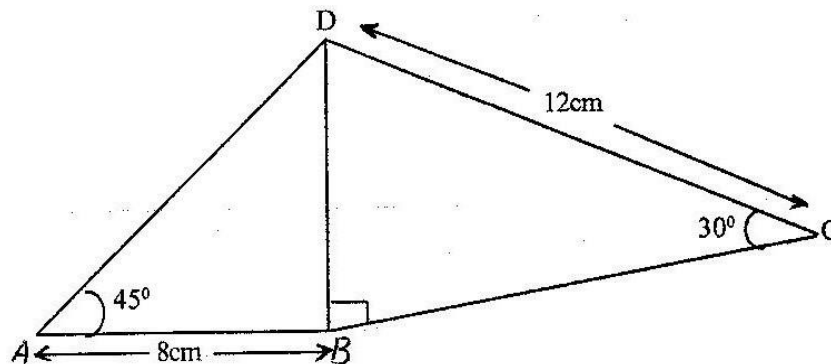

$\angle BAD = 45^\circ$, $\angle CBD = 90^\circ$ and $\angle BCD = 30^\circ$.

Find:

- (a) the length of BD (1 mark)
 (b) The size of the angle ADB (2 marks)

15. A bank either pays simple interest as 5% p.a or compound interest 5% p.a on deposits. Nekesa deposited Kshs P in the bank for two years on simple interest terms. If she had deposited the same amount for two years on compound interest terms, she would have earned Kshs 210 more.

Calculate without using Mathematics Tables, the values of P (4 marks)

16. The acceleration, $a \text{ ms}^{-2}$, of a particle is given by $a = 25 - 9t^2$, where t in seconds after the particle passes fixed point O.
 If the particle passes O, with velocity of 4 ms^{-1} , find
 (a) An expression of velocity V , in terms of t (2 marks)
 (b) The velocity of the particle when $t = 2$ seconds (2 marks)

SECTION II (48 marks)

Answer any six questions in this section

17. The distance between towns M and N is 280 km. A car and a lorry travel from M to N. The average speed of the lorry is 20 km/h less than that of the car. The lorry takes 1 h 10 min more than the car to travel from M and N.
 (a) If the speed of the lorry is $x \text{ km/h}$, find x (5 marks)
 (b) The lorry left town M at 8: 15 a.m. The car left town M and overtook the lorry at 12.15 p.m calculate the time the car left town M.
18. The points P, Q, R and S have position vectors $2p$, $3p$, r and $3r$ respectively, relative to an origin O. A point T divides PS internally in the ratio 1:6
 (a) Find, in the simplest form, the vectors OT and QT in terms P and r (4 marks)
 (b) (i) Show that the points Q, T, and R lie on a straight line (3 marks)
 (ii) Determine the ratio in which T divides QR (1 mark)
19. The diagram below represents a rectangular swimming pool 25m long and 10m wide. The sides of the pool are vertical.

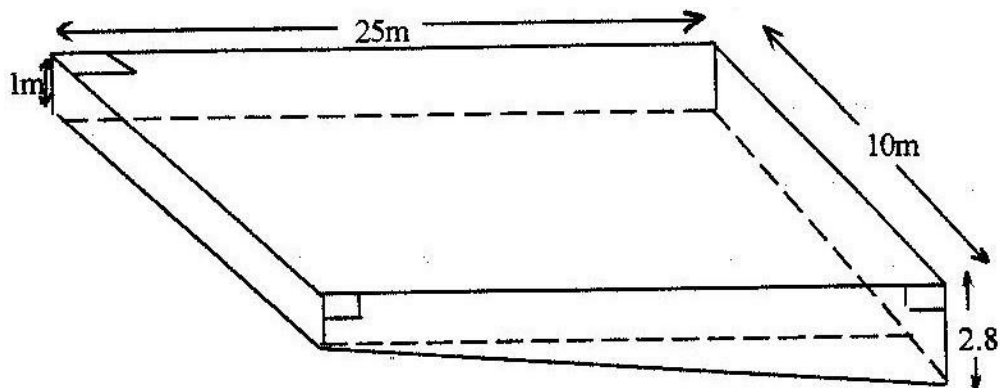

The floor of the pool slants uniformly such that the depth at the shallow end is 1m at the deep end is 2.8 m.

- Calculate the volume of water required to completely fill the pool.
- Water is allowed into the empty pool at a constant rate through an inlet pipe. It takes 9 hours for the water to just cover the entire floor of the pool.

Calculate:

- The volume of the water that just covers the floor of the pool (2 marks)
- The time needed to completely fill the remaining of the pool (3 marks)

20. The table below gives some of the values of x for the function $y = \frac{1}{2}x^2 + 2x + 1$ in the interval $0 \leq x \leq 6$.

x	0	1	2	3	4	5	6
y	1	3.5	7	11.5	17	23.5	31

- Use the values in the table to draw the graph of the function (2 marks)
- Using the graph and the mid – ordinate rule with six (6) strips, estimate the area bounded by the curve, the x- axis, the y- axis and the line $x = 6$
 - If the exact area of the region described in (b) (i) above is 78cm^2 , calculate the percentage error made when the mid – ordinate rule is used.

Give the answer correct to two decimal places (2 marks)

21. The gradient of a curve at point (x,y) is $4x - 3$. the curve has a minimum value of $\frac{1}{4}$

$-\frac{1}{8}$

- (a) Find
- (i) The value of x at the minimum point (1 mark)
 - (ii) The equation of the curve (4 marks)
- (b) P is a point on the curve in part (a) (ii) above. If the gradient of the curve at P is -7 , find the coordinates of P (3 marks)

22. The data below shows the masses in grams of 50 potatoes

Mass (g)	25- 34	35-44	45 - 54	55- 64	65 - 74	75-84	85-94
No of potatoes	3	6	16	12	8	4	1

- (a) On the grid provide, draw a cumulative frequency curve for the data (4mks)
- (b) Use the graph in (a) above to determine
- (i) The 60th percentile mass
 - (ii) The percentage of potatoes whose masses lie in the range 53 g to 68g (3mks)
23. A boat which travels at 5 km/h in still water is set to cross a river which flows from the north at 6km/h. The boat is set on a course of x° with the north.
- (a) Given that $\cos x^\circ = \frac{3}{5}$, calculate
- (i) The resultant speed of the boat (2 marks)
 - (ii) The angle which the track makes with the north (2 marks)
- (b) If the boat is to sail on a bearing of 135° , calculate the bearing of possible course on which it can be set (4 marks)

24. (a) (i) Complete the table below for the function $y = x^3 + x^2 - 2x$ (2 marks

x	-3	-2	-1	0	1	2	2.5
-2x	6	4	2	0	-2	-4	-5
x ²	9	4	1	0	1	4	6.25
x ³	-27	-8	-1	0	1	8	15.625
Y = x ³ + x ² - 2x							

- (ii) On the grid provided, draw the graph of $y = x^3 + x^2 - 2x$ for the values of x in the interval $-3 \leq x \leq 2.5$ (2 marks)

(iii) State the range of negative values of x for which y is also negative (1 mk)

(b) Find the coordinates of two points on the curve other than $(0,0)$ at which x -coordinate and y -coordinate are equal (3 marks)

121/2 MATHEMATICS PAPER 2 2005

SECTION I (52 Marks).

Answer all questions in this section

1. Find the value of y in the equation

$$243 \times 3^{2y} = 81$$

$$729 \times 3^y \text{ divide } 3^{(2y-1)}$$

(3 marks)

2. Without using mathematical Tables, simplify

$$\sqrt{63} + \sqrt{72}$$

$$\sqrt{32} + \sqrt{28}$$

(3 marks)

3. In a fund-raising committee of 45 people, the ratio of men to women is 7: 2. Find the number of women required to join the existing committee so that the ratio of men to women is changed to 5: 4 (3 marks)

4. The diagram below is a part of a figure which has

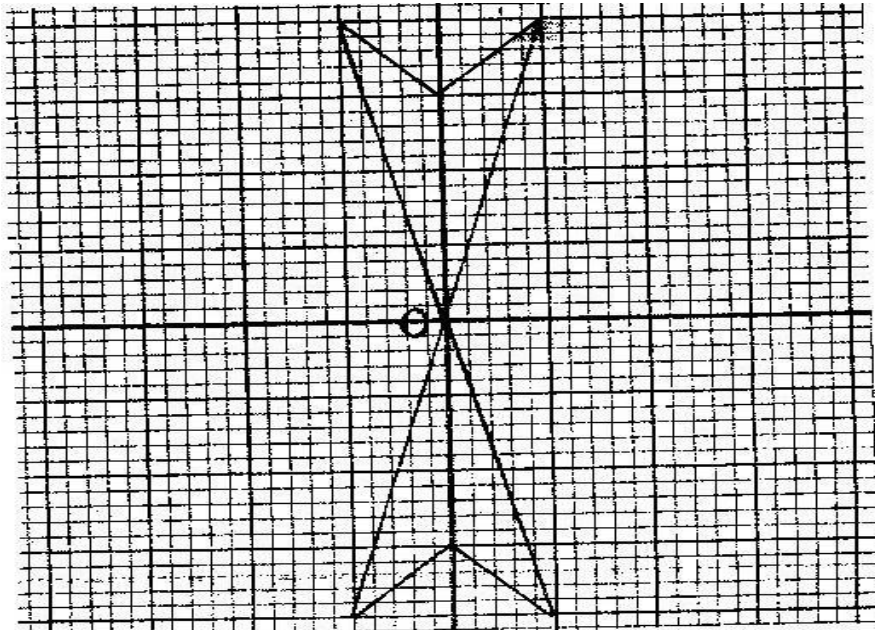

rotational symmetry of order 4 about O.

- (a) Complete the figure (1 mark)
- (b) Draw all the lines of symmetry of the completed figure (2 marks)
5. The first three consecutive terms of a geometrical progression are 3, x and $5\frac{1}{3}$.
Find the value of x. (2 marks)
6. Pipe a can fill an empty water tank in 3 hours while, pipe B can fill the same tank in 6 hours, when the tank is full it can be emptied by pipe C in 8 hours. Pipes A and B are opened at the same time when the tank is empty.
If one hour later, pipe C is also opened, find the total time taken to fill the tank
(4 marks) 7.
- Find, without using Mathematical Tables the values of x which satisfy the equation
 $\text{Log}_2(x^2 - 9) = 3 \log_2 2 + 1$ (4 marks)
8. The volumes of two similar solid cylinders are 4752 cm^3 and 1408 cm^3 . If the area of the curved surface of the smaller cylinder is 352 cm^2 , find the area of the curved surface of the larger cylinder. (4 marks)
9. Given that $\text{Cos } 2x^\circ = 0.8070$, find x when $0^\circ < x < 360^\circ$ (4 marks)
10. A salesman earns a basic salary of Kshs. 9000 per month
In addition he is also paid a commission of 5% for sales above Kshs 15000
In a certain month he sold goods worth Kshs. 120, 000 at a discount of $2\frac{1}{2}\%$
Calculate his total earnings that month (3 marks)

11. Successive moving averages of order 5 for the numbers 9,8.2, 6.7,5.4, 4.7 and k are A and B. Given that $A - B = 0.6$ find the value of k.
12. Two lines L_1 and L_2 intersect at a point P. L_1 passes through the points (-4,0) and (0,6). Given that L_2 has the equation: $y = 2x - 2$, find, by calculation, the coordinates of P. (3 marks)
13. Expand and simplify $(3x - y)^4$
Hence use the first three terms of the expansion to approximate the value of $(6-0.2)^4$ (4 marks)
14. The density of a solid spherical ball varies directly as its mass and inversely as the cube of its radius
When the mass of the ball is 500g and the radius is 5 cm, its density is 2 g per cm^3
Calculate the radius of a solid spherical ball of mass 540 density of 10g per cm^3

15. The figure below represents a prism of length 7 cm
 $AB = AE = CD = 2$ cm and $BC = ED = 1$ cm

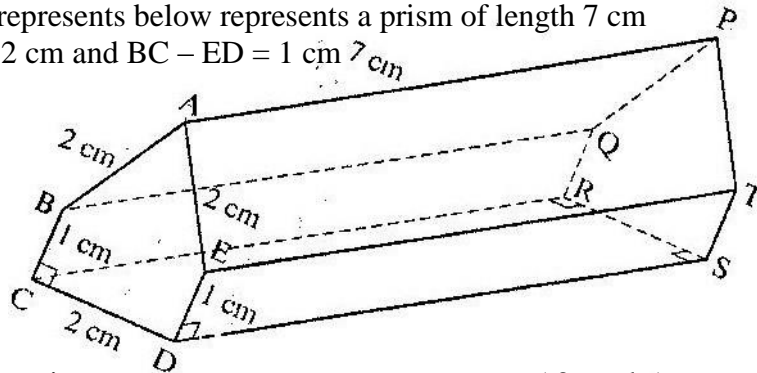

- Draw the net of the prism (3 marks)
16. A stone is thrown vertically upwards from a point O
After t seconds, the stone is S metres from O
Given that $S = 29.4t - 4.9t^2$, find the maximum height reached by the stone (3 marks)

SECTION II (48 marks)

Answer any six questions in this section

17. A curve is represented by the function $y = \frac{1}{3}x^3 + x^2 - 3x + 2$
- (a) Find $\frac{dy}{dx}$ (1 mark)
- (b) Determine the values of y at the turning points of the curve
 $y = \frac{1}{3}x^3 + x^2 - 3x + 2$ (4 marks)

18. Triangles ABC and A''B''C'' are drawn on the Cartesian plane provided. Triangle ABC is mapped onto A''B''C'' by two successive transformations
- $$R = \begin{pmatrix} a & b \\ c & d \end{pmatrix} \quad \text{Followed by } P = \begin{pmatrix} 0 & \\ -1 & \end{pmatrix}^{-1}$$
- 0
- (a) Find R (4 marks)
- (b) Using the same scale and axes, draw triangles A'B'C', the image of triangle ABC under transformation R (2 marks)
- (c) Describe fully, the transformation represented by matrix R (2 marks)
19. Abdi and Amoit were employed at the beginning of the same year. Their annual salaries in shillings progressed as follows:
- Abdi: 60,000, 64 800, 69, 600
Amoit 60,000, 64 800, 69 984
- (a) Calculate Abdi's annual salary increment and hence write down an expression for his annual salary in his nth year of employment(2 marks)
- (b) Calculate Amoit's annual percentage rate of salary increment and hence write down an expression for her salary in her nth year of employment. (2 marks)
- (c) Calculate the differences in the annual salaries for Abdi and Amoit in their 7th year of employment (4 marks)
20. (a) BCD is a rectangle in which AB = 7.6 cm and AD = 5.2 cm. draw the rectangle and construct the locus of a point P within the rectangle such that P is equidistant from CB and CD (3 marks)
- (b) Q is a variable point within the rectangle ABCD drawn in (a) above such that $600 \leq \angle AQB \leq 900$
On the same diagram, construct and show the locus of point Q, by leaving unshaded, the region in which point Q lies
21. (a) complete the table below, giving your values correct to 2 decimal places (2 marks)

x°	0	30	60	90	120	150	180
$2 \sin x^\circ$	0	1		2		1	
$1 - \cos x^\circ$			0.5	1			

- (b) On the grid provided, using the same scale and axes, draw the graphs of $y = \sin x^\circ$ and $y = 1 - \cos x^\circ$ for $0 \leq x \leq 180^\circ$

Take the scale: 2 cm for 30° on the x-axis
2 cm for 1 unit on the y-axis

- (c) Use the graph in (b) above to
- Solve equation $2 \sin x^\circ + \cos x^\circ = 1$ (1 mark)
 - Determine the range of values x for which $2 \sin x^\circ > 1 - \cos x^\circ$

(1 mark) 22.

A boat at point X is 200 m to the south of point Y. The boat sails X to another point Z. Point Z is 200m on a bearing of 310° from X, Y and Z are on the same horizontal plane.

- (b) calculate the bearing and the distance of Z from Y (3 marks) (b)
W is the point on the path of the boat nearest to Y.

Calculate the distance WY (2 marks)

- (c) A vertical tower stands at point Y. The angle of point X from the top of the tower is 6° calculate the angle of elevation of the top of the tower from W (3 marks)

23. The
a cuboid
 $FG = 4.5$
6 cm

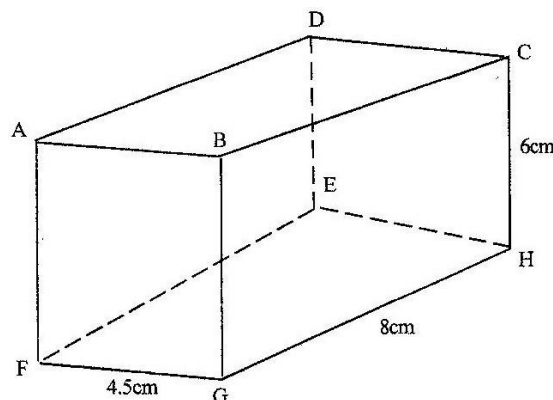

diagram below represents
ABCDEFGH in which
cm, $GH = 8\text{cm}$ and $HC =$

Calculate:

- (a) The length of FC (2 marks)
(b) (i) the size of the angle between the lines FC and FH (2 marks)

- (ii) The size of the angle between the lines AB and FH (2 marks)
- (c) The size of the angle between the planes ABHE and the plane FGHE (2mks)

24. diet expert makes up a food production for sale by mixing two ingredients N and S. One kilogram of N contains 25 units of protein and 30 units of vitamins. One kilogram of S contains 50 units of protein and 45 units of vitamins.

If one bag of the mixture contains x kg of N and y kg of S

- (a) Write down all the inequalities, in terms of x and representing the information above (2 marks)
- (b) On the grid provided draw the inequalities by shading the unwanted regions (2 marks)
- (c) If one kilogram of N costs Kshs 20 and one kilogram of S costs Kshs 50, use the graph to determine the lowest cost of one bag of the mixture (3 marks)

K.C.S.E 2006 MATHEMATICAL PAPER 121/1

SECTION 1 (50 MARKS)

Answer all the questions in this section

1. Without using mathematical tables or a calculator evaluate (4 marks)

$$3\sqrt{\frac{675 \times 135}{2025}}$$

2. All prime numbers less than ten are arranged in descending order to form a Number.

- (a) Write down the number formed (1 mark)
(b) State the total value of the second digit in the number formed in (a) above (1 mark)

3. Simplify

$$P^2 + 2pq + q^2$$

$$P^3 - pq^2 + p^2q - q^3$$

(4 marks)

4. In the regular (

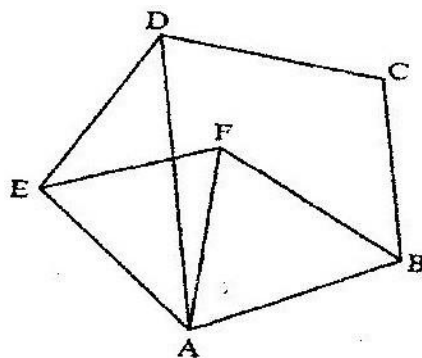

figure below, ABCDE is a pentagon and ABF is an equilateral triangle (1mark)

Find the size

of

- a) $\angle ADE$ (1 mark)
b) $\angle AEF$ (1 mark)
c) $\angle DAF$ (1 mark)

5. Solve the inequality $3 - 2x < x \leq 2x + 5$ and show the solution on the number line
6. The length of a rectangle is $(3x + 1)$ cm, its width is 3 cm shorter than its length. Given that the area of the rectangle is 28cm^2 , find its length.
7. In this question, mathematical table should not be used A Kenyan bank buys and sells foreign currencies as shown below

Buying

Selling

	(In Kenya shillings)	In Kenya Shillings
1 Hong Kong dollar	9.74	9.77
1 South African rand	12.03	12.11

A tourists arrived in Kenya with 105 000 Hong Kong dollars and changed the whole amount to Kenyan shillings. While in Kenya, she pent Kshs 403 897 and changed the balance to South African rand before leaving for South Africa. Calculate the amount, in South African rand that she received.

(3 marks)

8. In this question use a pair of compasses and a ruler only
- (a) construct triangle ABC such that $AB = 6$ cm, $BC = 8$ cm and $\angle ABC 135^0$
(2 marks)
- (b) Construct the height of triangle ABC in a) above taking BC as the base
(1 mark)
9. A line with gradient of -3 passes through the points (3. k) and (k.8). Find the value of k and hence express the equation of the line in the form $ax + by = c$, where a, b, and c are constants.

10. Without using mathematical tables or a calculator evaluate
 $6 \log_2 3 \sqrt{64} + 10 \log_3 5 \sqrt{243}$ (3 marks)

11. The diagram below represents a school gate with double shutters. The shutters are such opened through an angle of 63^0 . The edges of the gate, PQ and RS are each 1.8 m

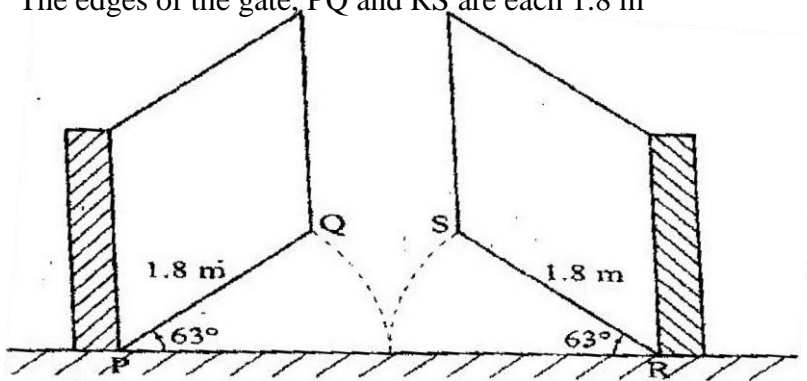

Calculate the shortest distance QS, correct to 4 significant figures (3 marks)

12. Two points P and Q have coordinates $(-2, 3)$ and $(1, 3)$ respectively. A translation map point P to $P' (10, 10)$
- (a) Find the coordinates of Q' the image of Q under the translation (1 mark)
- (b) The position vector of P and Q in (a) above are p and q respectively given that $mp - nq = \begin{pmatrix} -12 \\ 9 \end{pmatrix}$ (3 marks)

Find the value of m and n

13. The diagram below represents a right pyramid on a square base of side 3 cm. The slant of the pyramid is 4 cm.

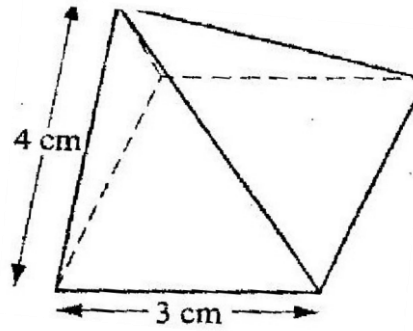

represents a base of side 3 cm pyramid is 4

- (a) Draw a net of the pyramid (2 marks)
- (b) On the net drawn, measure the height of a triangular face from the top of the Pyramid (1 mark)
14. Hadija and Kagendo bought the same types of pens and exercise books from the same shop
 Hadija bought 2 pens and 3 exercise books for Kshs 78. Kagendo bought pens and 4 exercise books for Kshs 108
 Calculate the cost of each item (3 marks)
15. The histogram below represents the distribution of marks obtained in a test. The bar marked A has a height of 3.2 units and a width of 5 units. The bar marked B has a height of 1.2 units and a width of 10 units

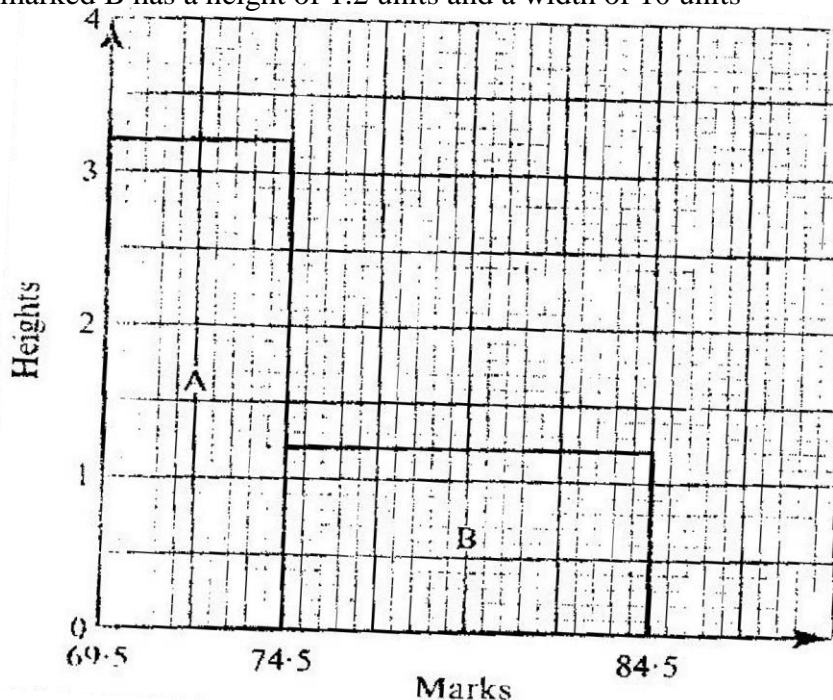

If the frequency of the class represented by bar B is 6, determine the frequency of the class represented by bar A.

16. A circle centre O, has the equation $x^2 + y^2 = 4$
 The area of the circle in the first quadrant is divided into 5 vertical strips of width 0.4 cm
- (a) Use the equation of the circle to complete the table below for values of y correct to 2 decimal places (1 mark)

X	0	0.4	0.8	1.2	1.6	2.0
Y	2.00			1.60		0

- (b) Use the trapezium rule to estimate the area of the circle (3 marks)

SECTION II (50 MARKS)

Answer any five questions in this section)

17. In the year 2001, the price of a sofa set in a shop was Kshs 12,000
- (a) Calculate the amount of money received from the sales of 240 sofa sets that year (2 marks)
- (b) (i) In the year 2002 the price of each sofa set increased by 25% while the number of sets sold decreased by 10%
 Calculate the percentage increase in the amount received from the sales (3 marks)
- (ii) If at the end of year 2002, the price of each sofa set changed in the ratio 16:15, calculate the price of each sofa set in the year 2003 (1 mark)
- (c) The number of sofa sets sold in the year 2003 was P% less than the number sold in the year 2001. Calculate the value of P, given that the amounts received from sales in the two years were equal. (4 marks)

18. on the Cartesian plane below, triangle PQR has vertices P(2, 3), Q (1,2) and R (4,1) while triangles P''Q''R'' has vertices P''(-2, 3), Q''(-1,2) and R''(4, 1)

P''Q''R'' has vertices P''(-2, 3), Q''(-1, 2) and R''(4, 1)

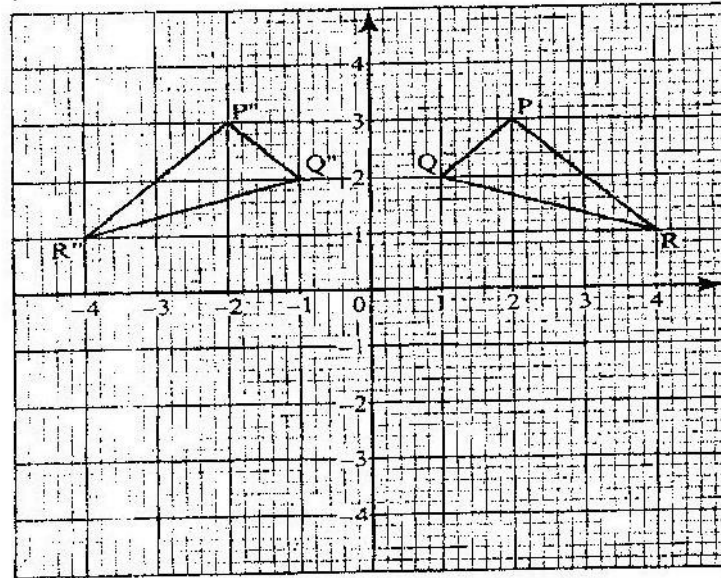

- (a) Describe fully a single transformation which maps triangle PQR onto triangle P''Q''R'' (2 marks)
- (b) On the same plane, draw triangle P'Q'R', the image of triangle PQR, under reflection in line $y = -x$ (2 marks)
- (c) Describe fully a single transformation which maps triangle P'Q'R' onto triangle P''Q''R'' (2 marks)
- (d) Draw triangle P'''Q'''R''' such that it can be mapped onto triangle PQR by a positive quarter turn about (0,0) (2 marks)
- (e) State all pairs of triangle that are oppositely congruent (2 marks)
19. The diagram below (not drawn to scale) represents the cross-section of a solid prism of height 8.0 cm (3 marks)

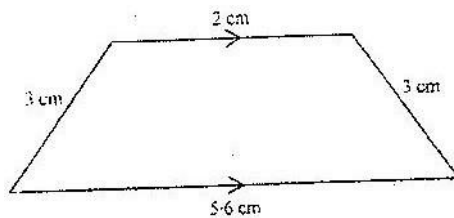

- (a) Calculate the volume of the prism (3 marks)
- (b) Given that the density of the prism is 5.75 g/cm^3 , calculate its mass in grams (2 marks)

- (c) A second prism is similar to first one but is made of a different material. The volume of the second is 246.24cm^3
- (i) calculate the area of the cross section of the second prism (3 marks) (ii)
Given that the ratio of the mass of the first to that of the second is 2: 5 and the density of the second prism (2 marks)

20. A bus left Mombasa and traveled towards Nairobi at an average speed of 60km/hr . after $2\frac{1}{2}$ hours; a car left Mombasa and traveled along the same road at an average speed of 100km/hr . If the distance between Mombasa and Nairobi is 500km , Determine

(a) (i) The distance of the bus from Nairobi when the car took off (2 marks)

(ii) The distance the car traveled to catch up with the bus

(b) Immediately the car caught up with the bus, the car stopped for 25 minutes. Find the new average speed at which the car traveled in order to reach Nairobi at

the same time as the bus. (4 marks)

21. The figure below represents a quadrilateral piece of land ABCD divided into three triangular plots. The lengths BE and CD are 100m and 80m respectively. Angle $\angle ABE = 30^\circ$, $\angle ACE = 45^\circ$ and $\angle ACD = 100^\circ$

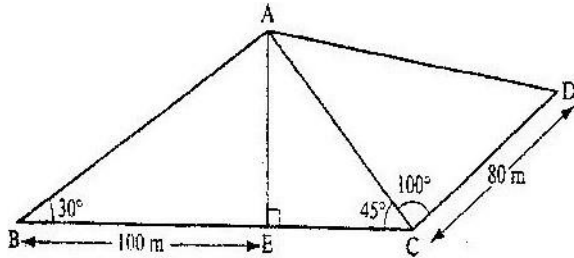

Find to four significant figures:

- (i) The length of AE (2 marks)
- (ii) The length of AD (3 marks)
- (iii) the perimeter of the piece of land (3 marks)
- (b) The plots are to be fenced with five strands of barbed wire leaving an entrance of 2.8m wide to each plot. The type of barbed wire to be used is sold in rolls of lengths 480m . Calculate the number of rolls of barbed wire that must be bought to complete the fencing of the plots (2 marks)

22. In the diagram below, the coordinates of points A and B are $(1,6)$ and $(15,6)$ respectively)

Point N
on OB
such that
 $ON = 2OB$.
Line OA

is
3
is

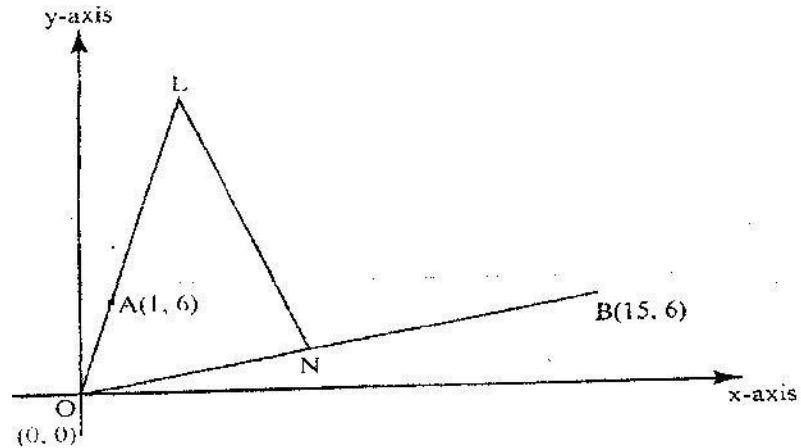

produced to L such that
 $OL = 3OA$

- (a) Find vector LN (3 marks)
- (b) Given that a point M is on LN such that $LM: MN = 3:4$, find the coordinates of M (2 marks)
- (c) If line OM is produced to T such that $OM: MT = 6:1$
 - (i) Find the position vector of T (1 mark)
 - (ii) Show that points L, T and B are collinear (4 marks)

23. The figure below is a model representing a storage container. The model whose total height is 15cm is made up of a conical top, a hemispherical bottom and the middle part is cylindrical. The radius of the base of the cone and that of the hemisphere are each 3cm. The height of the cylindrical part is 8cm.

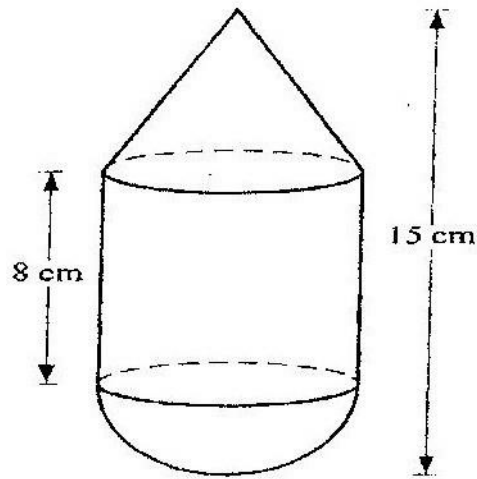

- (a) Calculate the external surface area of the model (4 marks)
- (b) The actual storage container has a total height of 6 metres. The outside of the actual storage container is to be painted. Calculate the amount of paint required if an area of 20m^2 requires 0.75 litres of the paint (6 marks)
24. A particle moves along straight line such that its displacement S metres from a given point is $S = t^3 - 5t^2 + 4$ where t is time in seconds Find
- (a) the displacement of particle at $t = 5$ (2 marks)
- (b) the velocity of the particle when $t = 5$ (3 marks)
- (c) the values of t when the particle is momentarily at rest (3 marks)
- (d) The acceleration of the particle when $t = 2$ (2 marks)

K.C.S.E 2006 MATHEMATICS PAPER 121/2
SECTION 1 (50 Marks)

1. In this question, show all the steps in your calculations, giving your answers at each stage

Use logarithms, correct to 4 decimal places, to evaluate (4 marks)

$$\sqrt[3]{\frac{36.72 \times (0.46)^2}{185.4}}$$

2. Make s the subject of the formula (4 marks)

$$\sqrt{P} = r \sqrt{1 - as^2}$$

3. In the figure below R , T and S are points on a circle centre O . PQ is a tangent to the circle at T . POR is a straight line and $\angle QPR = 20^\circ$

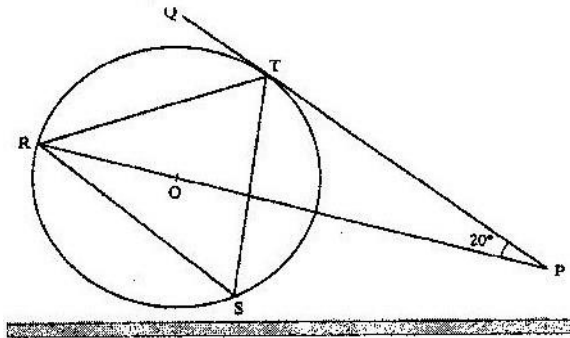

Find the size of $\angle RST$ (2 marks)

4. By correcting each number to one significant figure, approximate the value of 788×0.006 . Hence calculate the percentage error arising from this approximation.

(3 marks)

5. The data below represents the ages in months at which 6 babies started walking: 9, 11, 12, 13, 11, and 10. Without using a calculator, find the exact value of the variance (3 marks)

6. Without using a calculator or mathematical tables, simplify $3\sqrt{2} - \sqrt{3}$ (3 marks)

$$2\sqrt{3} - \sqrt{2}$$

7. The figure below shows a circle centre O and a point Q which is outside the circle

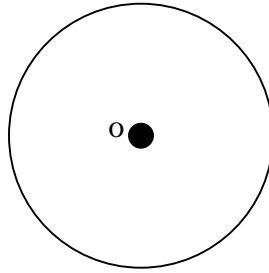

Using a ruler and a pair of compasses, only locate a point on the circle such that angle OPQ = 90° (2 marks)

8. The table below is a part of tax table for monthly income for the year 2004

Monthly taxable income In (kshs)	Tax rate percentage (%) in each shillings
Under Kshs 9681	10%
From Kshs 9681 but under 18801	15%
From Kshs 18801 but 27921	20%

In the tax year 2004, the tax of Kerubo's monthly income was Kshs 1916

Calculate Kerubos monthly income (3 marks)

9. Given that $q\mathbf{i} + \frac{1}{3}\mathbf{j} + \frac{2}{3}\mathbf{k}$ is a unit vector, find q (2 marks)
10. The points which coordinates (5,5) and (-3,-1) are the ends of a diameter of a circle centre A Determine:
 (a) the coordinates of A (1 mark)
 (b) The equation of the circle, expressing it in form $x^2 + y^2 + ax + by + c = 0$ where a, b, and c are constants (3 marks)
11. Use binomial expression to evaluate (4 marks)

$$\left(2 + \frac{1}{\sqrt{2}} \right)^5 + \left(2 - \frac{1}{\sqrt{2}} \right)^5$$
12. Three quantities t, x and y are such that t varies directly as x and inversely as the square root of y. Find the percentage in t if x decreases by 4% when y increases by 44% (4 marks)
13. The figure below is drawn to scale. It represents a field in the shape of an equilateral triangle of side 80m

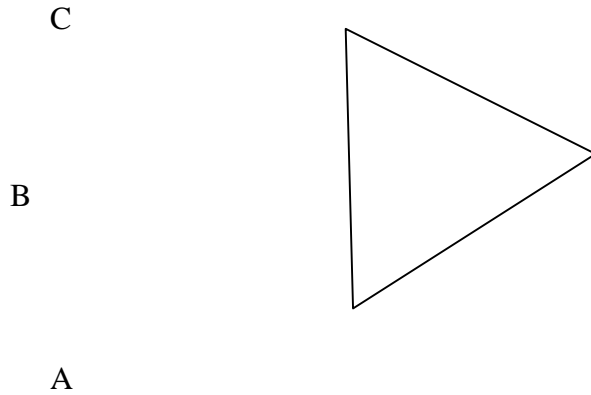

The owner wants to plant some flowers in the field. The flowers must be at most, 60m from A and nearer to B than to C. If no flower is to be more than 40m from BC, show by shading, the exact region where the flowers may be planted (4 marks)

14. The table shows some corresponding values of x and y for the curve represented by

$$Y = \frac{1}{4} x^3 - 2$$

X	-3	-2	-1	0	1	2	3	
Y	-8.8		-4	-2.3	-2	-1.8	0	4.8

On the grid provided below, draw the graph of $y = \frac{1}{4} x^3 - 2$ for $-3 \leq x \leq 3$. Use the graph to estimate the value of x when $y = 2$ (3 marks)

15. A particle moving in a straight line passes through a fixed point O with a velocity of 9m/s. The acceleration of the particle, t seconds after passing through O is given by $a = (10 - 2t) \text{ m/s}^2$. Find the velocity of the particle when t = 3 seconds (3 marks)

16. Two places P and Q are at ($36^\circ\text{N}, 125^\circ\text{W}$) and ($36^\circ\text{N}, 125^\circ\text{W}$) and ($36^\circ\text{N}, 125^\circ\text{W}$) and ($36^\circ\text{N}, 55^\circ\text{E}$) respectively. Calculate the distance in nautical miles between P and Q measured along the great circle through the North pole. (3 marks)

SECTION II (50 marks)

17. A certain sum of money is deposited in a bank that pays simple interest at a certain rate.

After 5 years the total amount of money in an account is Kshs 358 400. The interest earned each year is 12 800

Calculate

- (i) the amount of money which was deposited (2 marks)
 (ii) the annual rate of interest that the bank paid (2 marks)

(b) A computer whose marked price is Kshs 40,000 is sold at Kshs 56,000 on hire purchase terms.

(i) Kioko bought the computer on hire purchase term. He paid a deposit of 25% of the hire purchase price and cleared the balance by equal monthly installments of

Kshs 2625

Calculate the number of installments (3 marks)

(ii) Had Kioko bought the computer on cash terms he would have been allowed a discount of $12\frac{1}{2}\%$ on marked price. Calculate the difference between the cash price and the hire purchase price and express as a percentage of the cash price.

18. A garden measures 10m long and 8 m wide. A path of uniform width is made all round the garden. The total area of the garden and the paths is 168 m^2 .

(a) Find the width of the path (4 marks)

(b) The path is to be covered with square concrete slabs. Each corner of the path is covered with a slab whose side is equal to the width of the path.

The rest of the path is covered with slabs of side 50 cm. The cost of making each corner slab is Kshs 600 while the cost of making each smaller slab is Kshs 50.

Calculate

(i) The number of smaller slabs used (3 marks)

19. Triangle ABC is shown on the coordinates plane below

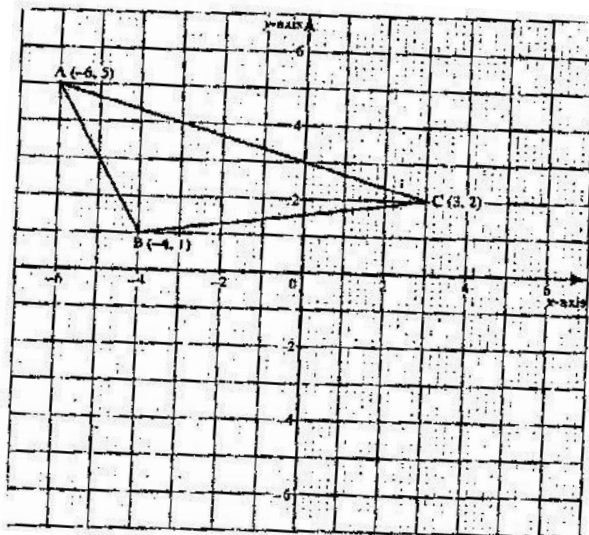

(a) Given that A (-6, 5) is mapped onto A' (6,-4) by a shear with y- axis invariant

(i) draw triangle A'B'B', the image of triangle ABC under the shear

(3 marks)

- (ii) Determine the matrix representing this shear (2 marks)
- (b) Triangle A B C is mapped on to A'' B'' C'' by a transformation defined by the matrix $\begin{pmatrix} 1 & 1 \\ 0 & 1 \end{pmatrix}$
- (i) Draw triangle A'' B'' C''
- (ii) Describe fully a single transformation that maps ABC onto A''B'' C''
20. (a) Two integers x and y are selected at random from the integers 1 to 8. If the same integer may be selected twice, find the probability that
- (i) $x - y = 2$ (2 marks)
- (ii) $x - y$ is more (2 marks)
- (iii) $x > y$ (2 marks)
- (b) A die is biased so that when tossed, the probability of a number r showing up, is given by $p \propto Kr$ where K is a constant and $r = 1, 2, 3, 4, 5$ and 6 (the number on the faces of the die)
- (i) Find the value of K (2 marks)
- (ii) if the die is tossed twice, calculate the probability that the total score is 11 (2 marks)
21. A solution whose volume is 80 litres is made 40% of water and 60% of alcohol. When litres of water are added, the percentage of alcohol drops to 40%
- (a) Find the value of x (4 marks)
- (b) Thirty litres of water is added to the new solution. Calculate the percentage (c) If 5 litres of the solution in (b) is added to 2 litres of the original solution, calculate in the simplest form, the ratio of water to that of alcohol in the resulting solution (4 marks)
22. The product of the first three terms of geometric progression is 64. If the first term is a, and the common ratio is r.
- (a) Express r in terms of a (3 marks)
- (b) Given that the sum of the three terms is 14
- (i) Find the value of a and r and hence write down two possible sequence each up to the 4th term.
- (ii) Find the product of the 50th terms of two sequences (2 marks)
23. Mwanjoki flying company operates a flying service. It has two types of aeroplanes. The smaller one uses 180 litres of fuel per hour while the bigger one uses 300 litres per hour.
- The fuel available per week is 18,000 litres. The company is allowed 80 flying hours per week while the smaller aeroplane must be flown for y hours per week.
- (a) Write down all the inequalities representing the above information (3 marks)

(b) On the grid provided on page 21, draw all the inequalities in a) above by shading the unwanted regions (3 marks)

(c) The profits on the smaller aeroplane is Kshs 4000 per hour while that on the bigger one is Kshs 6000 per hour

Use the graph drawn in (b) above to determine the maximum profit that the company made per week. (3 marks)

24. The diagram below shows a sketch of the line $y = 3x$ and the curve $y = 4 - x^2$ intersecting at points P and Q.

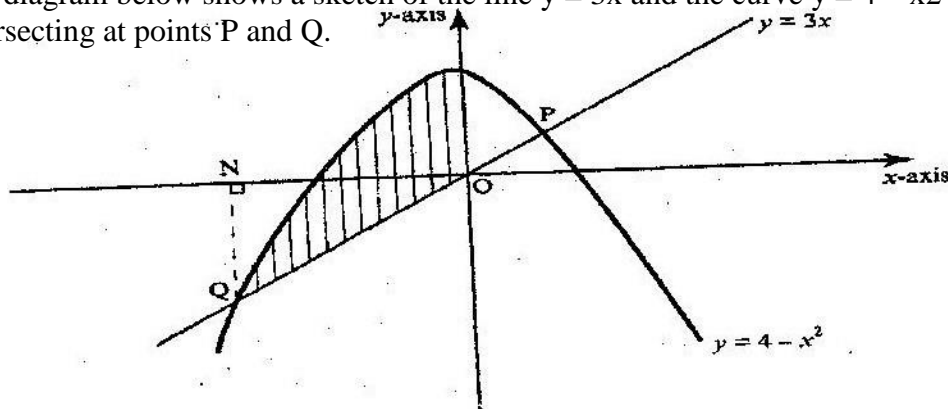

a) Find the coordinates of P and Q

(b) Given that QN is perpendicular to the x-axis at N, calculate

(i) The area bounded by the curve $y = 4 - x^2$, the x-axis and the line QN (2 marks)

(ii) The area of the shaded region that lies below the x-axis

(iii) The area of the region enclosed by the curve $y = 4 - x^2$, the line $y = 3x$ and the y-axis

K.C.S.E MATHEMATICS PAPER 1 2007

Answer all the questions in this section.

1. Evaluate without using mathematical tables or a calculator $\frac{0.0084 \times 1.23 \times 3.5}{2.87 \times 0.056}$

Expressing the answer as a fraction in its simplest form (2 marks)

2. The size of an interior angle of a regular polygon is $3x^\circ$ while its exterior angle is $(x - 20)^\circ$. Find the number of sides of the polygon (3 marks)

3. Expand the expression $(x^2 - y^2)(x^2 + y^2)(x^4 - y^4)$ (2 marks)

4. A Kenyan businessman bought goods from Japan worth 2, 950 000 Japanese yen. On arrival in Kenya custom duty of 20% was charged on the value of the goods. If the exchange rates were as follows

1 US dollar = 118 Japanese Yen

1 US dollar = 76 Kenya shillings

Calculate the duty paid in Kenya shillings (3 marks)

5. The gradient of the tangent to the curve $y = ax^3 + bx$ at the point (1,1) is -5
Calculate the values of a and b (4 marks)

6. Simplify the expression $\frac{15a^2b - 10ab^2}{3a^2 - 5ab + 2b^2}$ (3 marks)

7. A square brass plate is 2 mm thick and has a mass of 1.05 kg. The density of the brass is 8.4 g/cm^3 . Calculate the length of the plate in centimeters (3 marks)

8. Given that x is an acute angle and $\cos x = \frac{2\sqrt{5}}{5}$, find without using mathematical tables or a calculator, $\tan (90 - x)^\circ$.

9. A cylindrical solid of radius 5 cm and length 12 cm floats lengthwise in water to a depth of 2.5 cm as shown in the figure below.

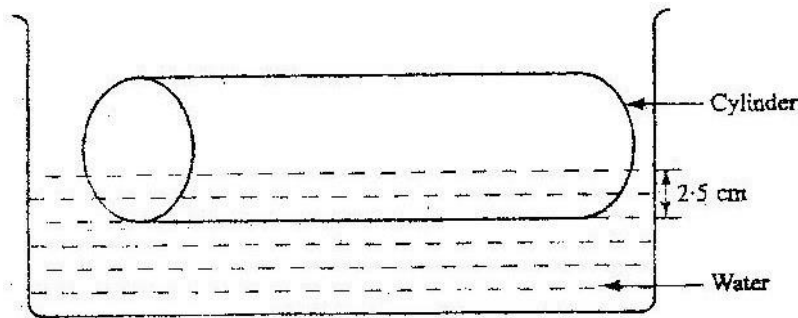

Calculate the area of the curved surface of the solid in contact with water, correct to 4 significant figures (4 marks)

10. In the figure
= 8.4 cm and

below $\angle A = 62^\circ$, $\angle B = 41^\circ$, BC
CN is the bisector of $\angle ACB$.

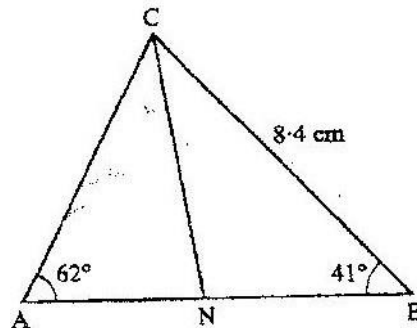

Calculate the length of CN to 1 decimal place. (3 marks)

11. In fourteen years time, a mother will be twice as old as her son. Four years ago, the sum of their ages was 30 years. Find how old the mother was, when the son was born. (4 marks)
12. (a) Draw a regular pentagon of side 4 cm (1 mark)
 (b) On the diagram drawn, construct a circle which touches all the sides of the pentagon (2 marks)
13. The sum of two numbers x and y is 40. write down an expression, in terms of x , for the sum of the squares of the two numbers.
 Hence determine the minimum value of $x^2 + y^2$ (4 marks)
14. In the figure below, PQR is an equilateral triangle of side 6 cm. Arcs QR, PR and PQ arcs of circles with centers at P, Q and R respectively.

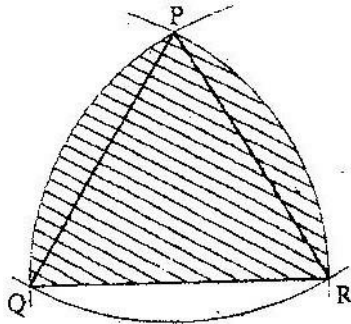

- Calculate the area of the shaded region to 4 significant figures (4 marks)
15. Points L and M are equidistant from another point K. The bearing of L from K is 330° . The bearing of M from K is 220° .
 Calculate the bearing of M from L
16. A rally car traveled for 2 hours 40 minutes at an average speed of 120 km/h. The car consumes an average of 1 litre of fuel for every 4 kilometers.
 A litre of the fuel costs Kshs 59
 Calculate the amount of money spent on fuel (3 marks)

SECTION II (50 marks)

Answer any five questions in this section

17. Three business partners: Asha Nangila and Cherop contributed Kshs 60,000, Kshs 85,000 and Kshs 105 000 respectively. They agreed to put 25% of the profit back into business each year. They also agreed to put aside 40% of the remaining profit to cater for taxes and insurance. The rest of the profit would then be shared among the partners in the ratio of their contributions. At the end of the first year, the business realized a gross profit of Kshs 225 000
 (a) Calculate the amount of money Cherop received more than Asha at the end of the first year (5 marks)

- (b) Nangila further invested Kshs 25,000 into the business at the beginning of the second year. Given that the gross profit at the end of the second year increased in the ratio 10: 9, calculate Nangila's share of the profit at the end of the second year. (5 marks)

18. In the diagram below PA represents an electricity post of height 9.6 m. BB and RC represents two storey buildings of heights 15.4 m and 33.4 m respectively. The angle of depression of A from B is 5.5° While the angle of elevation of C from B is 30.5° and $BC = 35\text{m}$.

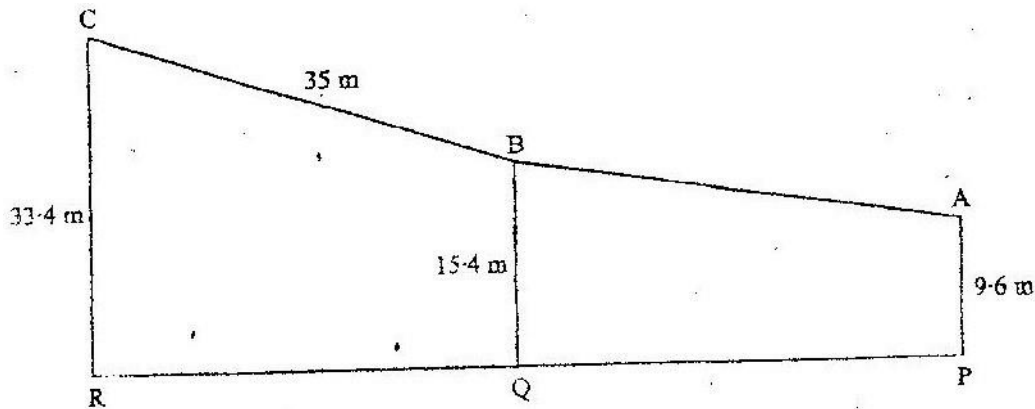

- (a) Calculate, to the nearest metre, the distance AB (2 marks)
- (b) By scale drawing find,
- The distance AC in metres (5 marks)
 - $\angle BCA$ and hence determine the angle of depression of A from C (3 marks)
19. A frequency distribution of marks obtained by 120 candidates is to be represented in a histogram. The table below shows the grouped marks. Frequencies for all the groups and also the area and height of the rectangle for the group 30 – 60 marks.

Marks	0-10	10-30	30-60	60-70	70-100
Frequency	12	40	36	8	24
Area of rectangle			180		
Height of rectangle			6		

- (a) (i) Complete the table (4 marks)
(ii) On the grid provided below, draw the histogram (2 marks)

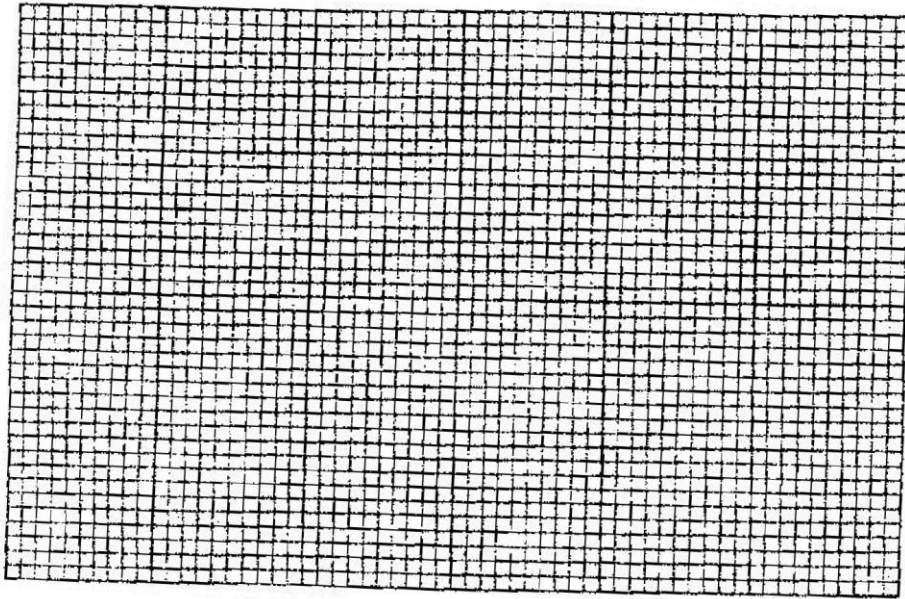

(b) (i) State the group in which the median mark lies (1 mark)

(ii) A vertical line drawn through the median mark divides the total area of the histogram into two equal parts

Using this information or otherwise, estimate the median mark (3mks)

20. A retailer planned to buy some computers form a wholesaler for a total of Kshs 1,800,000. Before the retailer could buy the computers the price per unit was reduced by Kshs 4,000. This reduction in price enabled the retailer to buy five more computers using the same amount of money as originally planned.

(a) Determine the number of computers the retailer bought (6 marks)

(b) Two of the computers purchased got damaged while in store, the rest were sold and the retailer made a 15% profit

Calculate the profit made by the retailer on each computer sold (4 marks)

21. In the figure below, $OQ = q$ and $OR = r$. Point X divides OQ in the ratio 1: 2 and Y divides OR in the ratio 3: 4 lines XR and YQ intersect at E.

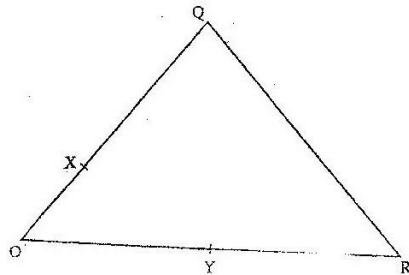

(a) Express in terms of q

(i) XR

and r

(1 mark)

(ii) YQ (1 mark)

(b) If $XE = m XR$ and $YE = n YQ$, express OE in terms of: (1 mark)

(i) r, q and m

(ii) r, q and n (1 mark)

(c) Using the results in (b) above, find the values of m and n. (6 marks)

22. Two cylindrical containers are similar. The larger one has internal cross-section area of 45cm^2 and can hold 0.945 litres of liquid when full. The smaller container has internal cross-section area of 20cm^2

(a) Calculate the capacity of the smaller container

(b) The larger container is filled with juice to a height of 13 cm. Juice is then drawn from it and emptied into the smaller container until the depths of the juice in both containers are equal.

Calculate the depths of juice in each container. (2marks)

(c) On fifth of the juice in the larger container in part (b) above is further drawn and emptied into the smaller container. Find the difference in the depths of the juice in the two containers. (4 marks)

23. (a) Find the inverse of the matrix $\begin{pmatrix} 9 & 8 \\ 7 & 6 \end{pmatrix}$ (2 marks)

(b) In a certain week a businessman bought 36 bicycles and 32 radios for total of Kshs 227 280. In the following week, he bought 28 bicycles and 24 radios for a total of Kshs 174 960

Using matrix method, find the price of each bicycle and each radio that he bought (4 marks)

(c) In the third week, the price of each bicycle was reduced by 10% while the price of each radio was raised by 10%. The businessman bought as many bicycles and as many radios as he had bought in the first two weeks.

Find by matrix method, the total cost of the bicycles and radios that the businessman bought in the third week. (4 marks)

24. The diagram on the grid below represents an extract of a survey map showing two adjacent plots belonging to Kazungu and Ndoe.

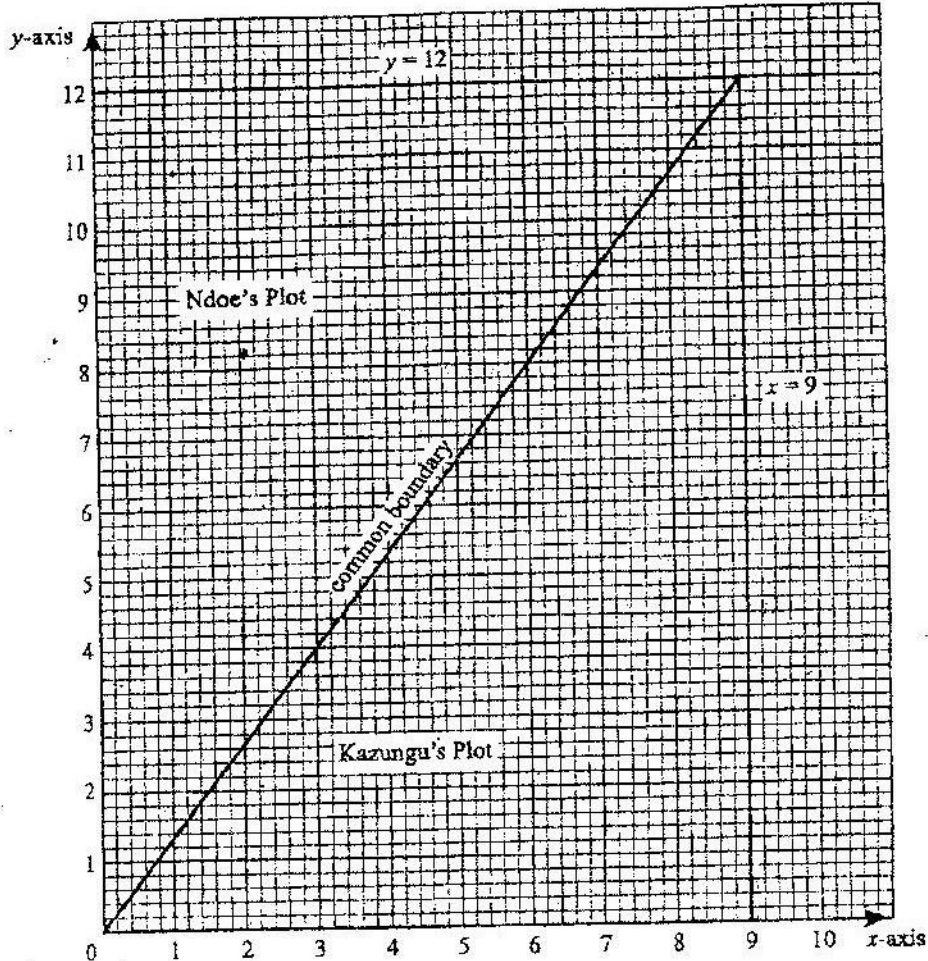

The two dispute the common boundary with each claiming boundary along different smooth curves coordinates (x, y) and (x, y_2) in the table below, represents points on the boundaries as claimed by Kazungu Ndoe respectively.

x	0	1	2	3	4	5	6	7	8	9
y_1	0	4	5.7	6.9	8	9	9.8	10.6	11.3	12
y_2	0	0.2	0.6	1.3	2.4	3.7	5.3	7.3	9.5	12

- (a) On the grid provided above draw and label the boundaries as claimed by Kazungu and Ndoe (2 marks)

K.C.S.E MATHEMATICS PAPER 2 2007
SECTION 1 (50 Marks)

Answer all the questions in this section

- Using logarithm tables, evaluate $\left(\frac{0.032 \times 14.26}{0.006} \right)^{2/3}$ (3 marks)
- Given that $y = 2x - z$, express x in terms of y and z (3 marks)

$$X + 3z$$

3. Solve the equation $3 \cos x = 2 \sin 2x$, where $0^\circ \leq x \leq 360^\circ$ (4 marks)
4. (a) Expand the expression $\left(1 + \frac{1}{2}x\right)^5$ in ascending powers of x , leaving the coefficients as fractions in their simplest form (2 marks)
- (b) Use the first three terms of the expansion in (a) above to estimate the value of $\left(1 \frac{1}{20}\right)^5$ (2 marks)
5. A particle moves in a straight line through a point P. Its velocity v m/s is given by $v = 2t - 1$, where t is time in seconds, after passing P. The distance s of the particle from P when $t = 2$ is 5 metres. Find the expression for s in terms of t . (3 marks)
6. The cash price of a T.V set is Kshs 13,800. A customer opts to buy the set on Hire purchase terms by paying a deposit of Kshs 2,280. If simple interest of 20% p.a is charged on the balance and the customer is required to repay by 24 equal monthly installments, calculate the amount of each installment. (3 marks)
7. Find the equation of a straight line which is equidistant from the points (2,3) and (6, 1), expressing it in the form $ax + by = c$ where a , b and c are constants (4 marks)
8. A rectangular block has a square base whose side is exactly 8 cm. Its height measured to the nearest millimeter is 3.1 cm. Find in cubic centimeters, the greatest possible error in calculating its volume. (2 marks)
9. Water and milk are mixed such that the ratio of the volume of water to that of milk is 4: 1. Taking the density of water as 1 g/cm^3 and that of milk as 1.2 g/cm^3 , find the mass in grams of 2.5 litres of the mixture. (3 marks)
10. A carpenter wishes to make a ladder with 15 cross- pieces. The cross- pieces are to diminish uniformly in length from 67 cm at the bottom to 32 cm at the top. Calculate the length in cm, of the seventh cross- piece from the bottom (3 marks)
11. In the figure below AB is a diameter of the circle. Chord PQ intersects AB at N. A tangent to the circle at B meets PQ produced at R.

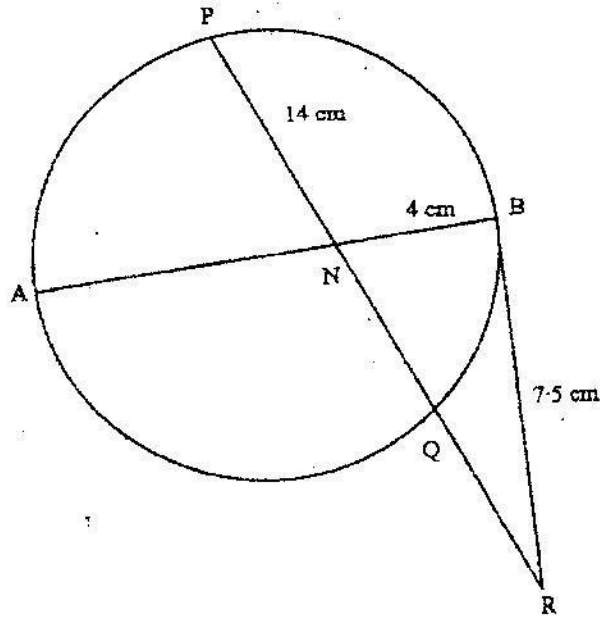

Given that $PN = 14\text{cm}$, $NB = 4\text{ cm}$ and $BR = 7.5\text{ cm}$, calculate the length of:

- (a) NR (1 mark)
 (b) AN (3 marks)

12. Vector q has a magnitude of 7 and is parallel to vector p . Given that $p = 3\mathbf{i} - \mathbf{j} + 1\frac{1}{2}\mathbf{k}$, express vector q in terms of \mathbf{i} , \mathbf{j} , and \mathbf{k} . (2 marks)
13. Two places A and B are on the same circle of latitude north of the equator. The longitude of A is 118°W and the longitude of B is 133°E . The shorter distance between A and B measured along the circle of latitude is 5422 nautical miles.
 Find, to the nearest degree, the latitude on which A and B lie (3 marks)

14. The figure below is a sketch of the graph of the function $y = (x+1)(x-2)$

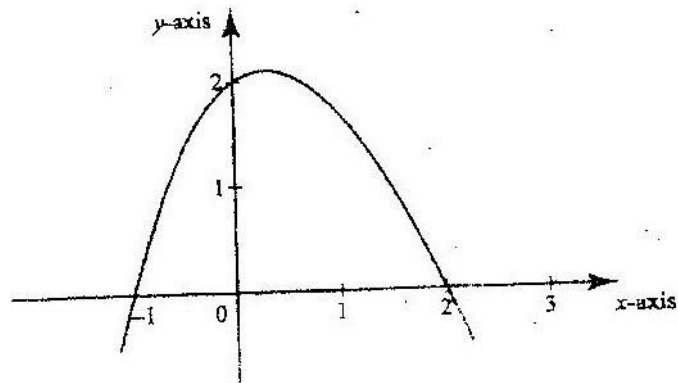

below is the graph of the quadratic function $y = (x+1)(x-2)$

Find the value of k

15. Simplify $3 + \frac{1}{\sqrt{5} - 2} - \frac{1}{\sqrt{5}}$ leaving the answer in the form $a + b\sqrt{c}$, where a, b and c are rational numbers (3 marks)
16. Find the radius and the coordinate of the centre of the circle whose equation is $2x^2 + 2y^2 - 3x + 2y + \frac{1}{2} = 0$ (4 marks)

SECTION 11 (50 MARKS)

Answer any five questions in this section

17. A tank has two inlet taps P and Q and an outlet tap R. when empty, the tank can be filled by tap P alone in $4\frac{1}{2}$ hours or by tap Q alone in 3 hours. When full, the tank can be emptied in 2 hours by tap R.
- (a) The tank is initially empty. Find how long it would take to fill up the tank
- (i) If tap R is closed and taps P and Q are opened at the same time (2 marks)
- (ii) If all the three taps are opened at the same time (2 marks)
- (b) The tank is initially empty and the three taps are opened as follows
- P at 8.00 a.m
Q at 8.45 a.m
R at 9.00 a.m
- (i) Find the fraction of the tank that would be filled by 9.00 a.m (3 marks)
- (ii) Find the time the tank would be fully filled up (3 marks)
18. Given that y is inversely proportional to x^n and k as the constant of proportionality;
- (a) (i) Write down a formula connecting y, x, n and k (1 mark)
- (ii) If $x = 2$ when $y = 12$ and $x = 4$ when $y = 3$, write down two expressions for k in terms of n.
Hence, find the value of n and k. (7 marks)
- (b) Using the value of n obtained in (a) (ii) above, find y when $x = 5\frac{1}{3}$ (2 marks)
19. (a) Given that $y = 8 \sin 2x - 6 \cos x$, complete the table below for the missing values of y, correct to 1 decimal place.

X	0 ^o	15 ^o	30 ^o	45 ^o	60 ^o	75 ^o	90 ^o	105 ^o	120 ^o
$Y = 8 \sin 2x - 6 \cos x$	-6	-1.8		3.8	3.9	2.4	0		-3.9

(b) On the grid provided, below, draw the graph of $y = 8 \sin 2x - 6 \cos x$ for $0^{\circ} \leq x \leq 120^{\circ}$

Take the scale 2 cm for 15^o on the x- axis

2 cm for 2 units on the y – axis (4 marks)

(c) Use the graph to estimate

(i) The maximum value of y (1 marks)

(ii) The value of x for which $4 \sin 2x - 3 \cos x = 1$ (3 marks)

20. The gradient function of a curve is given by the expression $2x + 1$. If the curve passes through the point $(-4, 6)$; (a) Find:

(i) The equation of the curve (3 marks)

(ii) The values of x, at which the curve cuts the x- axis (3 marks)

(b) Determine the area enclosed by the curve and the x- axis (4 marks)

21. In this question use a ruler and a pair of compasses only In the figure below, AB and PQ are straight lines

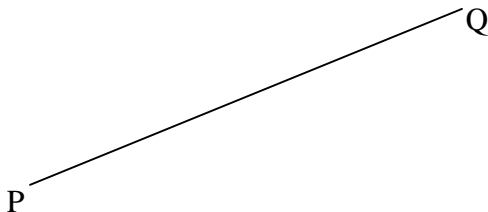

(a) Use the figure to:

(i) Find a point R on AB such that R is equidistant from P and Q (1 mark)

(ii) Complete a polygon PQRST with AB as its line of symmetry and hence measure the distance of R from TS. (5 marks)

(b) Shade the region within the polygon in which a variable point X must lie given that X satisfies the following conditions

I: X is nearer to PT than to PQ

II: RX is not more than 4.5 cm

III. $\angle PXT > 90^{\circ}$ (4 marks)

22. A company is considering installing two types of machines. A and B. The information about each type of machine is given in the table below.

Machine	Number of operators	Floor space	Daily profit
---------	---------------------	-------------	--------------

A	2	5m ²	Kshs 1,500
B	5	8m ²	Kshs 2,500

The company decided to install x machines of types A and y machines of type B

- (a) Write down the inequalities that express the following conditions
- I. The number of operators available is 40
 - II. The floor space available is 80m²
 - III. The company is to install not less than 3 type of A machine IV. The number of type B machines must be more than one third the number of type A machines
- (b) On the grid provided, draw the inequalities in part (a) above and shade the unwanted region (4 marks)
- (c) Draw a search line and use it to determine the number of machines of each type that should be installed to maximize the daily profit. (2 marks)

23. The table below shows the values of the length X (in metres) of a pendulum and the corresponding values of the period T (in seconds) of its oscillations obtained in an experiment.

X (metres)	0.4	1.0	1.2	1.4	1.6
T (seconds)	1.25	2.01	2.19	2.37	2.53

- (a) Construct a table of values of log X and corresponding values of log T, correcting each value to 2 decimal places (2 marks)
- (b) Given that the relation between the values of log X and log T approximate to a linear law of the form $m \log X + \log a$ where a and b are constants
- (i) Use the axes on the grid provided to draw the line of best fit for the graph of log T against log X. (2 marks)

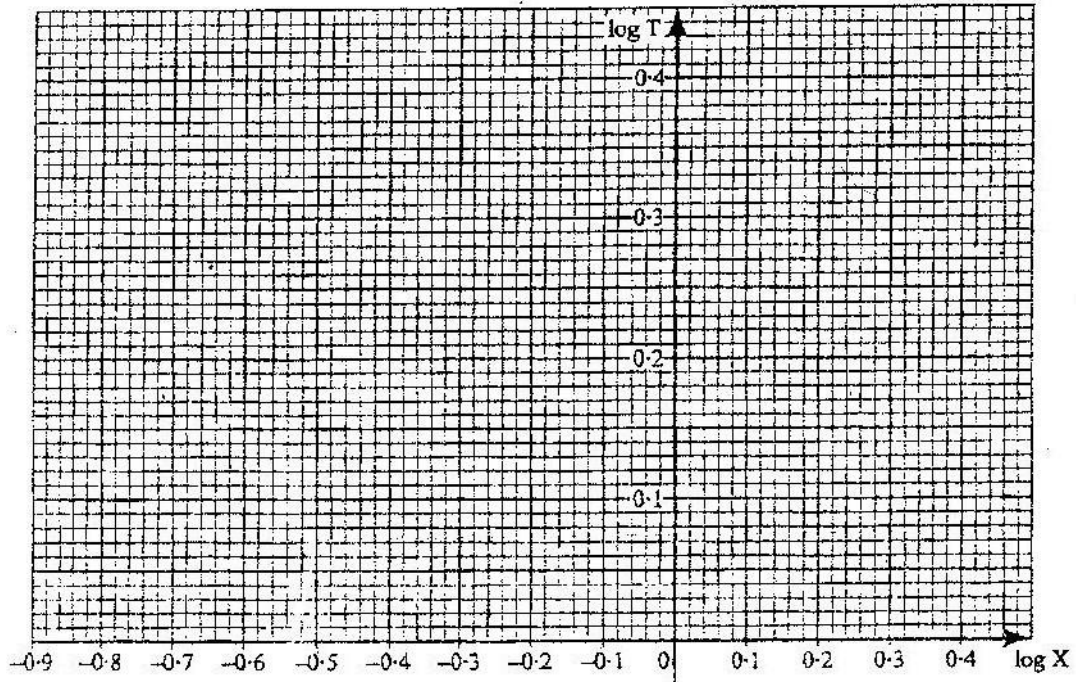

(ii) Use the graph to estimate the values of a and b (3 marks)

(b) Find, to decimal places the length of the pendulum whose period is 1 second (3 marks)

24. Two bags A and B contain identical balls except for the colours. Bag A contains 4 red balls and 2 yellow balls. Bag B contains 2 red balls and 3 yellow balls.

(a) If a ball is drawn at random from each bag, find the probability that both balls are of the same colour. (4 marks)

(b) If two balls are drawn at random from each bag, one at a time without replacement, find the probability that:

(i) The two balls drawn from bag A or bag B are red (4 marks)

(ii) All the four balls drawn are red (2 marks)

121/1

MATHEMATICS

Paper 1 Oct/Nov.

2008 2 ½ hours.

SECTION 1 (50 MAKS)

Answer all questions in this section.

1. Without using a calculator, evaluate $-8+(-5)\times(-8)-(-6)$
 $-3+(-8) \div 2 \times 4$ (2mks)
2. Simplify $\frac{27^{2/3}}{32^{-3/4}} \div 2^4$ (3mks)
3. Simplify the expression $\frac{a^4 - b^4}{a^3 - ab^2}$ (3mks)
4. Mapesa traveled by train from Butere to Nairobi. The train left Butere on a Sunday at 23 50 hours and traveled for 7 hours 15 minutes to reach Nakuru. After a 45 minutes stop in Nakuru, the train took 5 hours 40 minutes to reach Nairobi.
Find the time, in the 12 hours clock system and the day Mapesa arrived in Nairobi. (2mks)
5. The figure below shows a net of a solid

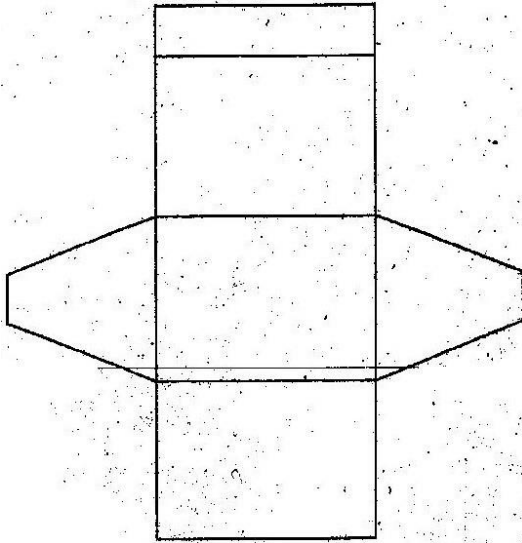

Below is a part of the sketch of the solid whose net is shown above.

Complete the sketch of the solid, showing the hidden edges with broken lines. (3mks)

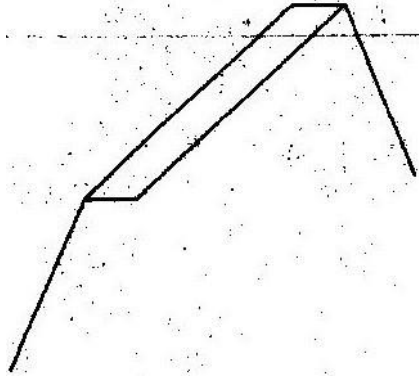

6. A fuel dealer makes a profit of Kshs. 520 for every 1000 litres of petrol sold and Ksh. 480 for every 1000 litres of diesel sold.
In a certain month the dealer sold twice as much diesel as petrol. If the total fuel sold that month was 900,000 litres, find the dealer's profit for the month. (3mks)

7. A liquid spray of mass 384g is packed in a cylindrical container of internal radius 3.2cm. Given that the density of the liquid is 0.6g/cm^3 , calculate to 2 decimal places the height of the liquid in the container. (3mks)

8. Line BC below is a side of a triangle ABC and also a side of a parallelogram BCDE.

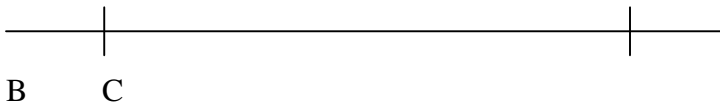

Using a ruler and a pair of compasses only construct:

- (i) The triangle ABC given that $\angle ABC = 120^\circ$ and $AB = 6\text{cm}$ (1mk)
- (ii) The parallelogram BCDE whose area is equal to that of the triangle ABC and point E is on line AB (3mks)
9. A solid metal sphere of radius 4.2 cm was melted and the molten material used to make a cube. Find to 3 significant figures the length of the side of the cube. (3mks)
10. An angle of 1.8 radians at the centre of a circle subtends an area of length 23.4cm
Find;
- a) The radius of the circle (2mks)
- b) The area of the sector enclosed by the arc and the radii. (2mks)
11. Three vertices of a rhombus ABCD are; A(-4,-3), B(1,-1) and c are constants. (2mks)
- a) Draw the rhombus on the grid provided below. (2mks)
- b) Find the equation of the line AD in the form $y = mx + c$, where m and c are constants. (2mks)

12. Two matrices A and B are such that $A = \begin{pmatrix} k & 4 \\ 3 & 2 \end{pmatrix}$ and $B = \begin{pmatrix} 1 & 2 \\ 3 & 4 \end{pmatrix}$

Given that the determinant of $AB = 4$, find the value of k.

13. A rectangular and two circular cut-outs of metal sheet of negligible thickness are used to make a closed cylinder. The rectangular cut-out has a height of 18cm. Each circular cut-out has a radius of 5.2cm. Calculate in terms of π , the surface area of the cylinder (3mks)
14. Given that $\log 4 = 0.6021$ and $\log 6 = 0.7782$, without using mathematical tables or a calculator, evaluate $\log 0.096$. (3mks)
15. The equation of line L_1 is $2y - 5x - 8 = 0$ and line L_2 passes through the points $(-5, 0)$ and $(5, -4)$. Without drawing the lines L_1 and L_2 show that the two lines are perpendicular to each other. (3mks)
16. Solve the equation;
 $2 \cos 2\theta = 1$ for $0^\circ \leq \theta \leq 360^\circ$ (4mks)

SECTION II (50 MKS)

Answer any five questions in this section.

17. a) The ratio of Juma's and Akinyi's earnings was 5:3. Juma's earnings rose to Ksh 8400 after an increase of 12%.
 Calculate the percentage increase in Akinyi's earnings given that the sum of their new earnings was Ksh. 14100. (6mks)
- b) Juma and Akinyi contributed all the new earnings to buy maize at Ksh 1175 per bag. The maize was then sold at Ksh 1762.50 per bag. The two shared all the money from the sales of the maize in the ratio of their contributions.

Calculate the amount that Akinyi got. (4mks)

18. The figure below is a sketch of the curve whose equation is $y = x^2 + x + 5$. It cuts the line $y = 11$ at points P and Q.

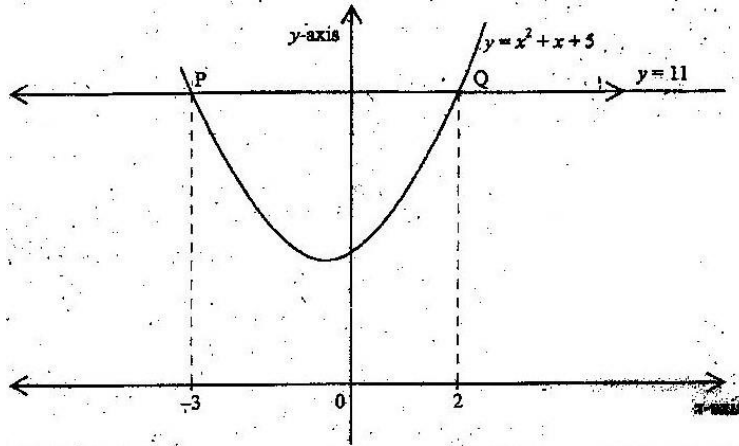

- a) Find the area bounded by the curve $y = x^2 + x + 5$ and the line $y = 11$ using the trapezium rule with 5 strips. (5mks)
- b) Calculate the difference in the area if the mid-ordinate rule with 5 ordinates was used instead of the trapezium rule. (5mks)

- 19 In the figure below $AB = p$, $AD = q$, $DE = \frac{1}{2} AB$ and $BC = \frac{2}{3} BD$

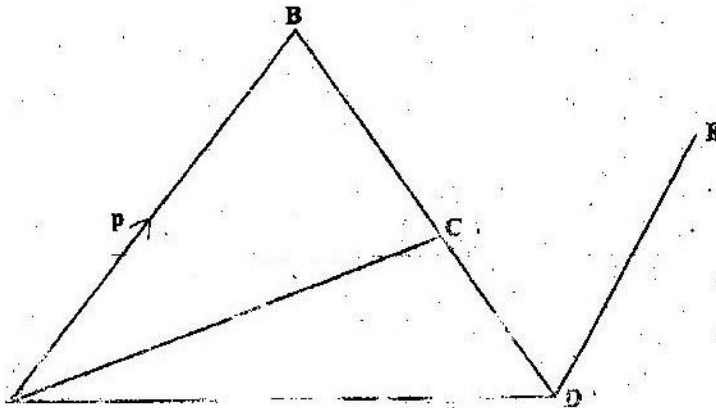

- a) Find in terms of p and q the vectors: (1mk)
- (i) \vec{BD} ; (1mk)
- (ii) \vec{BC} ; (1mk)
- (iii) \vec{CD} ; (1mk)
- (iv) \vec{AC} . (2mks)
- b) Given that $\vec{AC} = k\vec{CE}$, where k is a scalar, find
- (i) The value of k (4mks)
- (ii) The ratio in which C divides AE (1mk)

20. The diagram below represents two vertical watch-towers AB and CD on a level ground. P and Q are two points on a straight road BD . The height of the tower

AB is 20m road a BD is 200m.

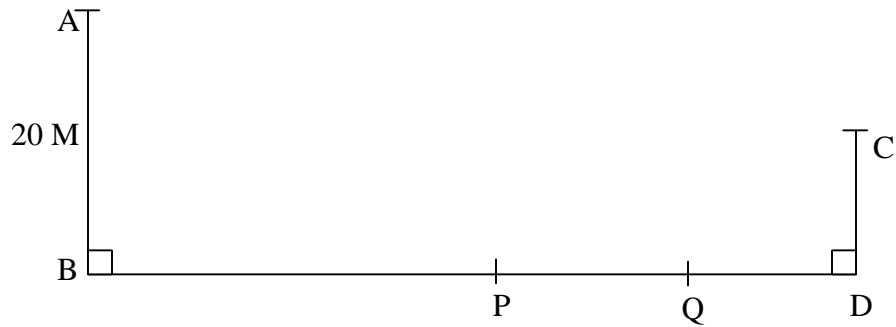

- A car moves from B towards D. At point P, the angle of depression of the car from point A is 11.3° . Calculate the distance BP to 4 significant figures. (2mks)
- If the car takes 5 seconds to move from P to Q at an average speed of 36 km/h, calculate the angle of depression of Q from A to 2 decimal places (3mks)
- Given that $QC=50.9\text{m}$, calculate;
 - The height of CD in meters to 2 decimal places; (2mks)
 - The angle of elevation of A from C to the nearest degree. (3mks)

21. The diagram below shows a triangle ABC with A (3, 4), B (1, 3) and C (2, 1).

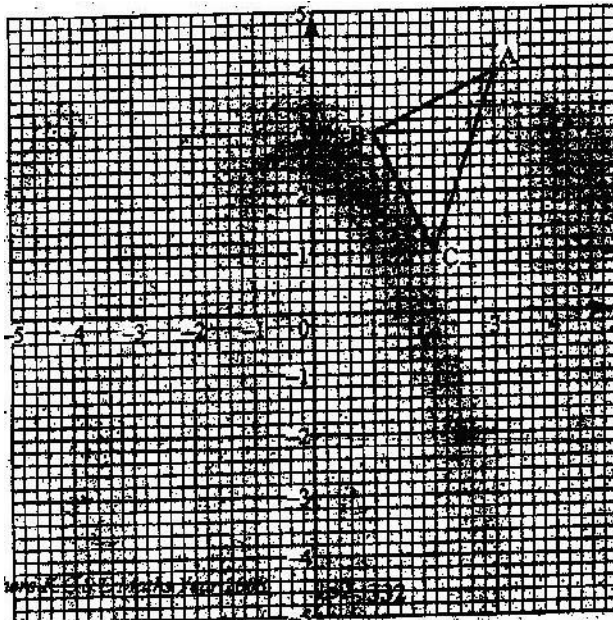

- Draw A 'B'C' the image of ABC under a rotation of $+90^\circ$ about (0, 0). (2mks)
- Drawn A "B" the image of A "B'C" under a reflection in the line $y=x$. (2mks)
- Draw A. "B" C. the image under a rotation of -90° about (0, 0) (2mks)

- d) Describe a single transformation that maps ABC'' onto $A'''B'''C'''$
(2mks)
- e) Write down the equations of the lines of symmetry of the quadrilateral $BB''A'''A$ (2mks)

22. The diagram below represents a conical vessel which stands vertically. The vessels contains water to a depth of 30cm. The radius of the surface in the vessel is 21cm. (Take $\pi=22/7$).

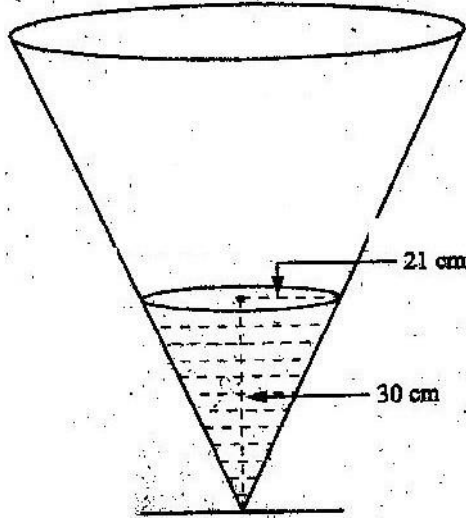

- a) Calculate the volume of the water in the vessels in cm^3
- b) When a metal sphere is completely submerged in the water, the level of the water in the vessels rises by 6cm.
Calculate:
- (i) The radius of the new water surface in the vessel; (2mrks)
- (ii) The volume of the metal sphere in cm^3 (3mks)
- (iii) The radius of the sphere. (3mks)
23. A group of people planned to contribute equally towards a water project which needed Ksh 200 000 to complete, However, 40 members of the group without from the project.
As a result, each of the remaining members were to contribute Ksh 2500.
- a) Find the original number of members in the group. (5mks)
- b) Forty five percent of the value of the project was funded by Constituency Development Fund (CDF). Calculate the amount of contribution that would be made by each of the remaining members of the group. (3mks)
- c) Member's contributions were in terms of labour provided and money contributed. If the ratio of the value of labour to the money contributed was 6:19; calculate the total amount of money contributed by the members. (2mks)

24. The distance s metres from a fixed point O , covered by a particle after t seconds is given by the equation; $S = t^3 - 6t^2 + 9t + 5$.
- Calculate the gradient to the curve at $t=0.5$ seconds (3mks)
 - Determine the values of s at the maximum and minimum turning points of the curve. (4mks)
- c) On the space provided, sketch the curve of $s = t^3 - 6t^2 + 9t + 5$. (3mks) **121/2**

MATHEMATICS

Paper 2

Oct/Nov 2008

2 ½ hours

SECTION I (50 MARKS)

Answer all the questions in this section in the spaces provided.

1. In this question, show all the steps in your calculations, giving the answer each stage. Use logarithms correct to decimal places, to evaluate.

$$\frac{6.373 \log 4.948}{\sqrt{0.004636}}$$

(3mks)

2. Make h the subject of the formula

(3mks)

$$q = \frac{1+rh}{1-ht}$$

3. Line AB given below is one side of triangle ABC . Using a ruler and a pair of compasses only;

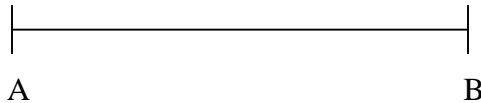

- Complete the triangle ABC such that $BC=5\text{cm}$ and $\angle ABC=45^\circ$
- On the same diagram construct a circle touching sides AC , BA produced and BC produced.

4. The position vectors of points A and B are $\begin{pmatrix} 3 \\ -1 \\ -4 \end{pmatrix}$ and $\begin{pmatrix} 8 \\ -6 \\ 6 \end{pmatrix}$ respectively.

A point P divides AB in the ratio $2:3$. Find the position Vector of point P .

(3mks)

5. The top of a table is a regular hexagon. Each side of the hexagon measures 50.0 cm. Find the maximum percentage error in calculating the perimeter of the top of the table. (3mks)

6. A student at a certain college has a 60% chance of passing an examination at the first attempt. Each time a student fails and repeats the examination his chances of passing are increased by 15%

Calculate the probability that a student in the college passes an examination at the second or at the third attempt. (3mks)

7. An aero plane flies at an average speed of 500 knots due East from a point p (53.4° E) to another point Q. It takes $2\frac{1}{4}$ hours to reach point Q.

Calculate:

- (i) The distance in nautical miles it traveled; (1mk)
 (ii) The longitude of point Q to 2 decimal places (2mks)

8. a) Expand and simplify the expression

$$\left(10 + \frac{2}{x}\right)^5$$

(2mks)

- b) Use the expansion in (a) above to find the value of 14^5 (2mks)

9. In the figure below, angles BAC and ADC are equal. Angle ACD is a right angle. The ratio of the sides.

AC: BC = 4: 3

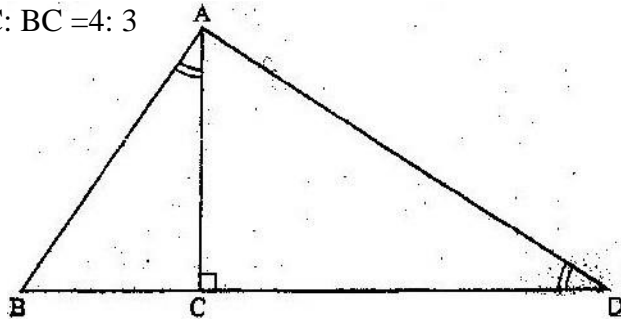

Given that the area of triangle ABC is 24 cm^2 . Find the triangle ACD (3mks)

10. Points A(2,2) and B(4,3) are mapped onto A'(2,8) and B'(4,15) respectively by a transformation T.

Find the matrix of T. (4mks)

11. The equation of a circle is given by $4x^2 + 4y^2 - 8x + 20y - 7 = 0$.

Determine the coordinates of the centre of the circle. (3mks)

12. Solve for y in the equation $\log_{10}(3y+2) - 1 - \log_{10}(y-4)$ (3mks)

13. Without using a calculator or mathematical tables, express

$\sqrt{3}$ in surd form and simplify

$1 - \cos 30^{\circ}$ (3mks)

14. The figure below represents a triangular prism. The faces ABCD, ADEF and

CBFE are rectangles.

AB=8cm, BC=14cm, BF=7cm and AF=7cm.

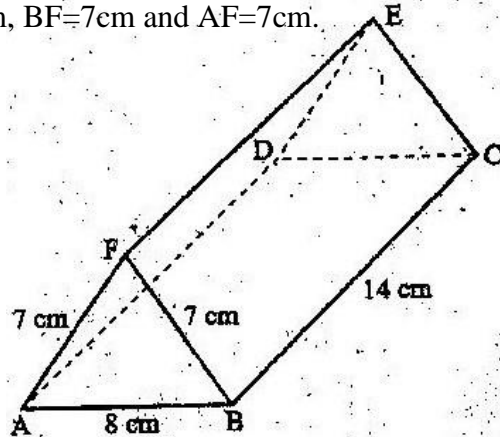

15. Calculate the angle between faces BCEF and ABCD. (3mks)
 A particle moves in a straight line from a fixed point. Its velocity V m/s after t seconds is given by $V=9t^2 - 4t + 1$

Calculate the distance traveled by the particle during the third second. (3mks)

16. Find in radians, the values of x in the interval $0^0 \leq x \leq 2\pi^{0+}$ for which $2 \cos^2 x = 1$.
 (Leave the answers in terms of π) (4mks)

SECTION II (50MKS)

Answer any five questions in this section.

17. a) A trader deals in two types of rice; type A and with 50 bags of type B. If he sells the mixture at a profit of 20%, calculate the selling price of one bag of the mixture. (4mks)
 b) The trader now mixes type A with type B in the ratio $x: y$ respectively. If the cost of the mixture is Ksh 383.50 per bag, find the ratio $x: y$. (4mks)
 c) The trader mixes one bag of the mixture in part (a) with one bag of the mixture in part (b). Calculate the ratio of type A rice to type B rice in this mixture. (2mks)
18. Three variables p, q and r are such that p varies directly as q and inversely as the square of r .
- (a) When $p=9, q=12$ and $r = 2$.
 Find p when $q= 15$ and $r =5$ (4mks)
- (b) Express q in terms of p and r . (1mks)
- (c) If p is increased by 10% and r is decreased by 10%, find;
 (i) A simplified expression for the change in q in terms of p and r (3mks)
 (ii) The percentage change in q . (2mks)
19. a) complete the table below, giving the values correct to 2 decimal places.

x°	0	30	60	90	120	150	180	210	240	270	300	330	360
$\sin 2x$	0		0.87		-0.87		0	0.87	0.87				0
$3\cos x - 2$	1	0.60		-2	-3.5			-4.60			-0.5		1

- b) On the grid provided, draw the graphs of $y = \sin 2x$ and $y = 3\cos x - 2$ for $0^{\circ} \leq x \leq 360^{\circ}$ on the same axes. Use a scale of 1 cm to represent 30° on the x-axis and 2cm to represent 1 unit on the y-axis.
- c) Use the graph in (b) above to solve the equation $3 \cos x - \sin 2x = 2$.
(2mks)
- d) State the amplitude of $y = 3\cos x - 2$.
(1mk)
20. In the figure below DA is a diameter of the circle ABCD centre O, radius 10cm. TCS is a tangent to the circle at C, $AB = BC$ and angle $DAC = 38^{\circ}$

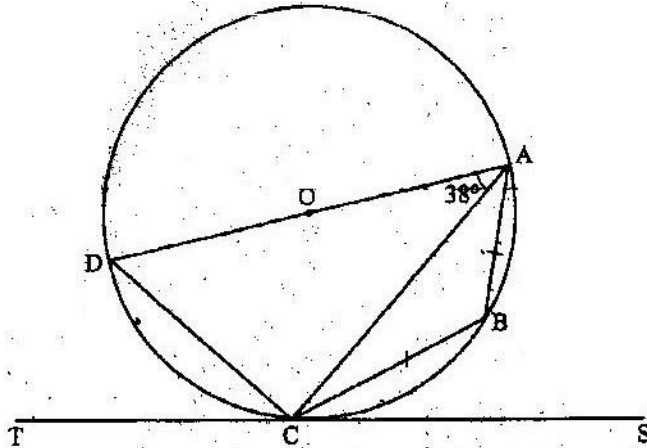

- a) Find the size of the angle;
 (i) ACS; (2mks)
 (ii) BCA (2mks)
- b) Calculate the length of:
 (i) AC (2mks)
 (ii) AB (4mks)
21. Two policemen were together at a road junction. Each had a walkie talkie. The maximum distance at which one could communicate with the other was 2.5 km. One of the policemen walked due East at 3.2 km/h while the other walked due North at 2.4 km/h the policeman who headed East traveled for x km while the one who headed North traveled for y km before they were unable to communicate.
- (a) Draw a sketch to represent the relative positions of the policemen. (1mk)
- (b) (i) From the information above form two simultaneous equations in x and y .
(2mks)
22. The table below shows the distribution of marks scored by 60 pupils in a test.

Marks	11-20	21-30	31-40	41-50	51-60	61-70	71-80	81-90
Frequency	2	5	6	10	14	11	9	3

- a) On the grid provided, draw an ogive that represents the above information
(4mks)
- b) Use the graph to estimate the interquartile range of this information.
(3mks)

23. Halima deposited Ksh. 109375 in a financial institution which paid simple interest at the rate of 8% p.a. At the end of 2 years, she withdrew all the money. She then invested the money in share. The value of the shares depreciated at 4% p.a. during the first year of investment. In the next 3 years, the value of the shares appreciated at the rate of 6% every four months

- a) Calculate the amount Halima invested in shares. (3mks)
- b) Calculate the value of Halima's shares.
- (i) At the end of the first year;
(2mks)
- (ii) At the end of the fourth year, to the nearest shilling. (3mks)
- c) Calculate Halima's gain from the share as a percentage.
(2mks)
- (ii) Find the values of x and y. (5mks)
- (iii) Calculate the time taken before the policemen were unable to communicate. (2mks)

24. The table below shows values of x and some values of y for the curve $y = x^3 + 3x^2 - 4x - 12$ in the range $-4 \leq x \leq 2$.

- a) Complete the table by filling in the missing values of y.

X	-4	-3.5	-3	-2.5	-2	-1.5	-1	-0.5	0	0.5	1	1.5	2.0
Y		-4.1		-1.1			-9.4	-9.0		-13.1		-7.9	

- b) On the grid provided, draw the graph $y = x^3 + 3x^2 - 4x - 12$ for $-4 \leq x \leq 2$.

Use the scale. Horizontal axis 2cm for 1 unit and vertical axis 2cm for 5 units.

- (3mks)
- c) By drawing a suitable straight line on the same grid as the curve, solve the equation $x^3 + 3x^2 - 5x - 6 = 0$ (5mks)

MATHEMATICS

SECTION I (50 mks)

PAPER 1

Answer all the questions in this section in the spaces provided

1.

Without using mathematical tables or calculator, evaluate

$$\underline{\quad \sqrt{5184} \quad}$$

$$6 \times 18 \div 9 + (5-3)$$

(3 mks)

2. Without using a calculator, evaluate, $\frac{2\frac{1}{4} + \frac{3}{5} \div \frac{5}{6} \text{ of } 2\frac{2}{5}}{1\frac{7}{10}}$ leaving the answer as a fraction in its simplest form (3 mks)

3. Given that the ratio $x : y = 2 : 3$, find the ratio $(5x-2y) : (x+y)$ (3 mk)

4. A bus traveling at an average speed of 63 km/h left a station at 8.15 a.m. find the average speed of the car. (3 mks)

5. Without using Logarithm tables or calculators, evaluate, $\frac{64\frac{1}{2} \times 27000^{2/3}}{2^4 \times 3^0 \times 5^2}$ (4 mks)

6. The figure below represents a plot of land ABCD such that $AB = 85$ m, $BC = 75$ m, $CD = 60$ m $DA = 50$ m and angle $ABC = 90^\circ$

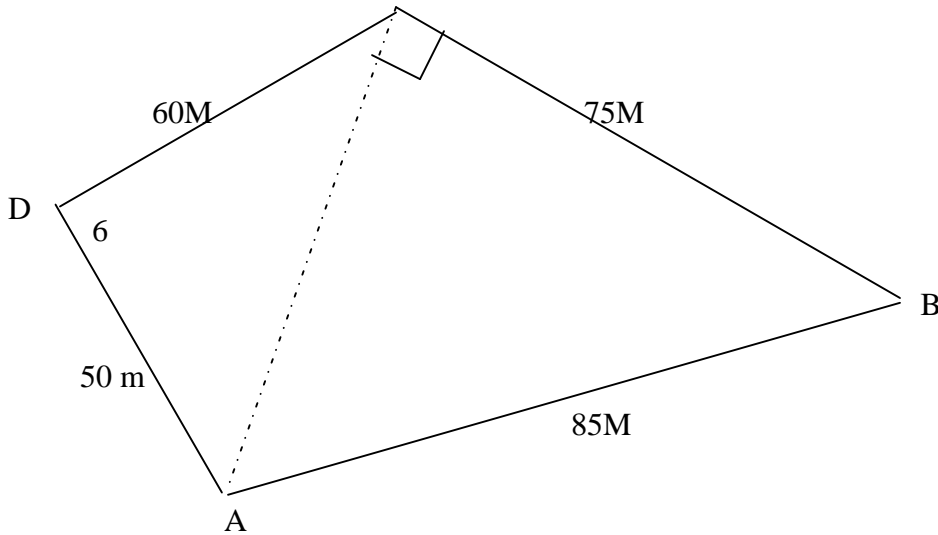

Determine the area of the plot in hectares correct to two decimal places. (4 mks)

7. A watch which loses a half-minute every hour was set to read the correct time at 05 45 h on Monday. Determine the time in the 12- hour system, the watch will show on the following Friday at 19 45h

(3 mks)

8. Simplify the expression $\frac{12x^2}{2} + \frac{ax}{2} - 6a^{2+}$

$$9x - 4a$$

(3 mks)

9. A line which joins the points A (3, k) and B (-2, 5) is parallel to another line whose equation is $5y + 2x = 10$

Find the value of k.

(3 mks)

10. The size of an interior angle of a regular polygon is $6\frac{1}{2}$ times that of its exterior angle determine the number of sides of the polygon.

(3 mks)

11. Line AB shown below is a side of a trapezium ABCD in which angle ABC is 105° , BC = 4 cm, CD = 5 cm and CD is parallel to AB.



Using a ruler and a pair of compasses only:

- a) Complete the trapezium; (3 mks)
- b) Locate point t on line AB such that angle ATD = 90° (1 mk)

12. An electric pole is supported to stand vertically on a level ground by a tight wire. The wire is pegged at a distance of 6 metres from the foot of the pole as shown.

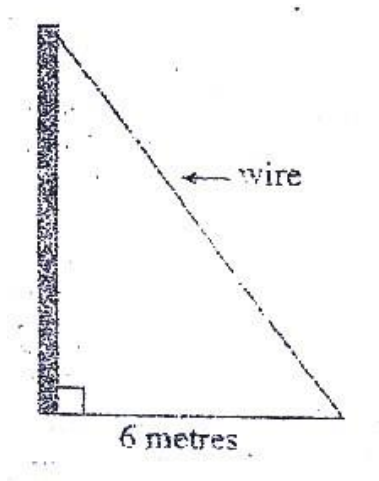

The angle which the wire makes with the ground is three times the angle it makes with the pole.

Calculate the length of the wire to the nearest centimeter. (3 mks)

13. Give the equation: $\sin(3x + 30^\circ) = \sqrt{3}$, for $0^\circ \leq x \leq 90^\circ$ (4 mks)

14. The diagonals of a rhombus PQRS intersect at T. Given that $p(2,2)$, $Q(3, 6)$ and $R(-1, 5)$:

a) Draw the rhombus PQRS on the grid provided; (1 mk)

b) State the coordinates of T. (1 mk)

15. Abdi sold a radio costing Kshs 3 800 at a profit of 20%. He earned a commission of $22\frac{1}{2}\%$ on the profit. Find the amount he earned. (2 mks)

16. The following data was obtained for the masses of certain animals.

Mass (x kg)	Frequency
$1.5 \leq x < 5.5$	16
$5.5 \leq x < 7.5$	20
$7.5 \leq x < 13.5$	18
$13.5 \leq x < 15.5$	14

Complete the histogram on the grid provided

(3 mks)

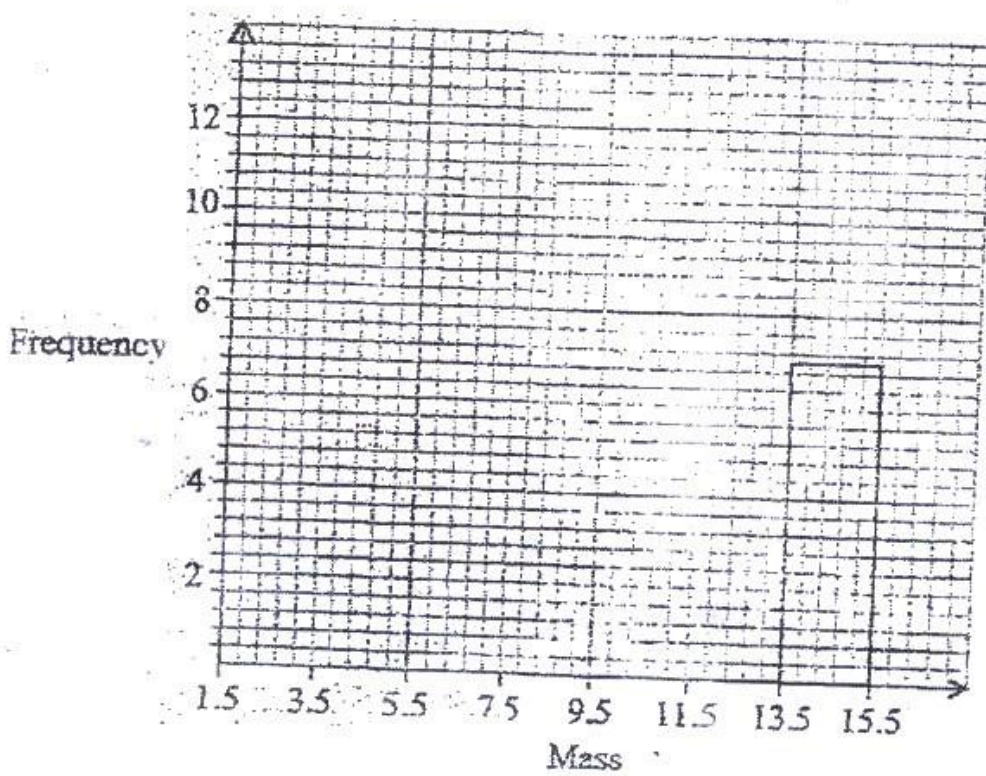

SECTION II (50 MARKS)

Answer only five questions in this section in the spaces provided.

- 17 In the figure below (not drawn to scale), $AB = 8\text{ cm}$, $AC = 6\text{ cm}$, $AD = 7\text{ cm}$, $CD = 2.82\text{ cm}$ and angle $CAB = 50^\circ$

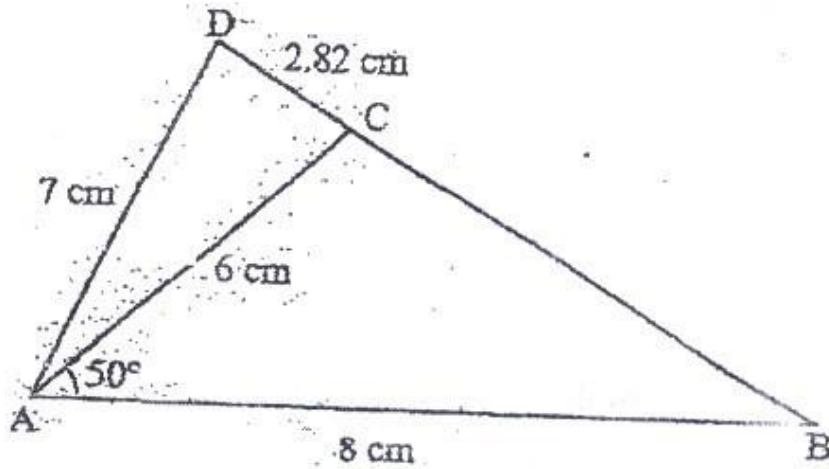

Calculate, to 2 decimal places

- The length BC, (2 mks)
 - The size of angle ABC, (3 mks)
 - The size of angle CAD, (3 mks)
 - The area of triangle ACD (2 mks)
-
- Express vector NM in terms of OB (1 mk)

c) Point P maps onto P by a translation $\begin{pmatrix} -5 \\ 8 \end{pmatrix}$ given that

$OP = OM + 2 MN$, find the coordinates of P.(3 mks)

18. The marks scored by a group of pupils in a mathematics test were as recorded in the table below

Marks	Frequency
0 -9	1
10-19	2
20-29	4
30-39	7
40-49	10
50-59	16
60-69	20
70-79	6
80-89	3
90-99	1

a) i) State the modal class (1 mk)

ii) Determine the class in which the median mark lies (2 mks)

- b) Using an assumed mean of 54.4, calculate the mean mark (7 mks)

19.

A school planned to buy x calculators for a total cost of Kshs 16 200. The supplier agreed to offer a discount of Kshs 60 per calculator. The school was then able to get three extra calculators for the same amount of money.

- a) Write an expression in terms of x , for the:

i) Original price of each calculator. (1 mk)

ii) Price of each calculator after the discount (1 mk)

- b) Form an equation in x and hence determine the number of calculators the School bought. (5 mks)

c) Calculate the discount offered to the school as a percentage (3 mks)

20. The position vectors of points A and B with respect to the origin O, are

$$\begin{pmatrix} -8 \\ \end{pmatrix} \text{ and } \begin{pmatrix} -12 \\ \end{pmatrix} \text{ respectively}$$

5 -5

a) Find:

i) The coordinates of N and M; (3 mks)

ii) The magnitude of Nm (3 mks)

21. A glass, in the form of a frustum of a cone, is represented by the diagram below.
The glass contains water to a height of 9 cm,. The bottom of the glass is a circle of radius 2 cm while the surface of the water is a circle of radius 6 cm.

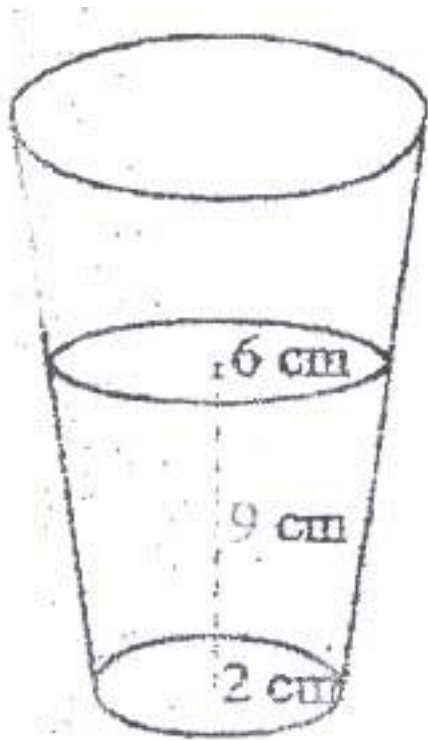

- a) Calculate the volume of the water in the glass (3 mks)
- b) When a spherical marble is submerged into the water in the glass, the water level rises by 1 cm.

Calculate:

- i) The volume of the marble; (4 mks)
- ii) The radius of the marble (3 mks)

22. The diagram below shows the speed-time graph for a train traveling between two stations. The train starts from rest and accelerates uniformly for 150 seconds. It

then travels at a constant speed for 300 seconds and finally decelerates uniformly for 200 seconds.

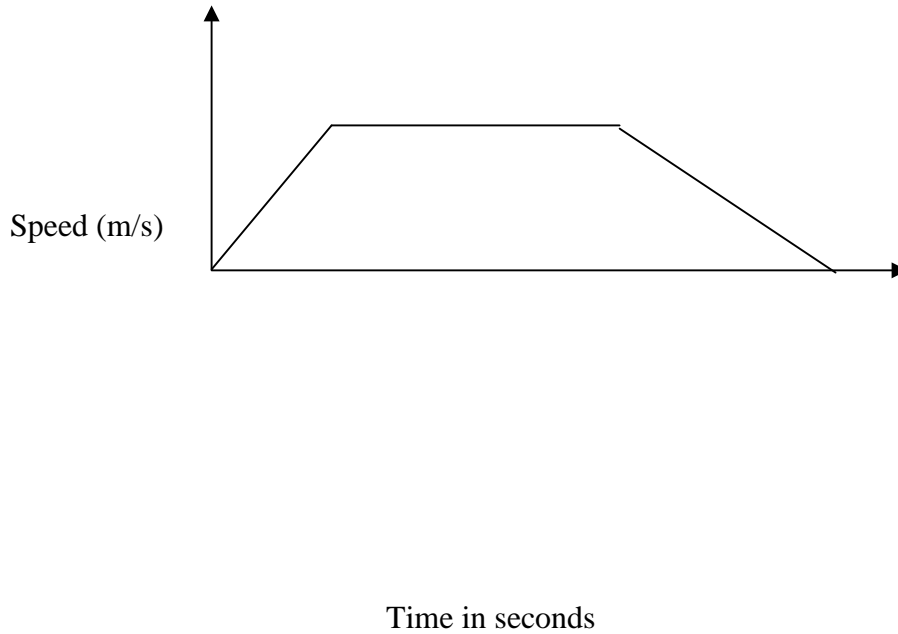

Given that the distance between the two stations is 10 450 m, calculate

the:

- a) Maximum speed, in Km/h, the train attained; (3 mks)
- b) Acceleration, (2 mks)
- c) Distance the train traveled during the last 100 seconds; (2 mks)
- d) Time the train takes to travel the first half of the journey. (3mks)

23. Three points P, Q and R are on a level ground. Q is 240 m from P on a bearing of 230° . R is 120 m to the east of P

- a) Using a scale of 1 cm to represent 40 m, draw a diagram to show the positions of P, Q and R in the space provided below. (2 mks)
- b) Determine
- i) The distance of R from Q (2 mks)
- ii) The bearing of R from Q (2 mks)
- c) A vertical post stands at P and another one at Q. A bird takes 18 seconds to fly directly from the top of the post at q to the top of the post at P.

Given that the angle of depression of the top of the post at P from the top of the post at Q is 9° ,

Calculate:

- i) The distance to the nearest metre, the bird covers; (2 mks)
- ii) The speed of the bird in Km/h (2 mks)

24. a) On the grid provided, draw a graph of the function

$$Y = \frac{1}{2}x^2 - x + 3 \text{ for } 0 \leq x \leq 6 \quad (3 \text{ mks})$$

- b) Calculate the mid-ordinates for 5 strips between $x=1$ and $x=6$, and hence Use the mid-ordinate rule to approximate the area under the curve between $x=1$, $x=6$ and the x -axis. (3 mks)
- c) Assuming that the area determined by integration to e the actual area, calculate the percentage error in using the mid-ordinate rule. (4 mks)

THE YEAR 2009

MATHEMATICS PAPER 2

SECTION (50 MKS)

Answer all the questions in this section in the spaces provided.

1. A farmer feed every two cows on 480 Kg of hay for four days. The farmer has 20 160 Kg of hay which is just enough to feed his cows for 6 weeks.
Find the number of cows in the farm. (3 mks)
2. find a quadratic equation whose roots are $1.5 + \sqrt{2}$ and $1.5 - \sqrt{2}$,
expressing it in the form $ax^2 + bx + c = 0$, where a , b and c are integers

(3 mks)

3. The mass of a wire m grams (g) is partly a constant and partly varies as the square of its thickness t mm. when $t = 2$ mm, $m = 40$ g and when $t = 3$ mm, $m = 65$ g

Determine the value of m when $t = 4$ mm. (4 mks)

4. In the figure below, O is the centre of the circle and radius ON is perpendicular to the line TS at N .

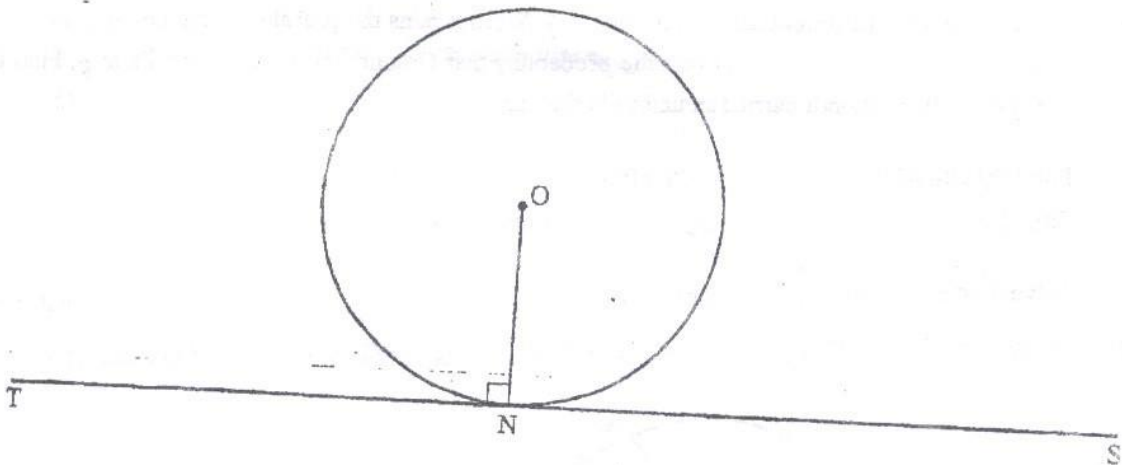

Using a ruler and a pair of compasses only, construct a triangle ABC to inscribe the circle, given that angle ABC = 60° , BC = 12 cm and points B and C are on the line TS (4 mks)

5. a solution was gently heated, its temperature readings taken at intervals of 1 minute and recorded as shown in the table below .

Time(Min)	0	1	2	3	4	5
Temperature ($^\circ\text{C}$)	4	5.2	8.4	14.3	16.3	17.5

- a) Draw the time-temperature graph on the grid provided (2 mks)
- b) Use the graph to find the average rate of change in temperature Between $t = 1.8$ and $t = 3.4$ (2 mks)

6. Vector $\text{OA} = \begin{pmatrix} 2 \\ 1 \end{pmatrix}$ and $\text{OB} = \begin{pmatrix} 6 \\ -3 \end{pmatrix}$ is on OB such that $\text{CB} = 2 \text{OC}$ and

Point D is on AB such that $\text{AD} = 3 \text{DB}$.

Express CD as a column vector. (3mks)

7. In a certain commercial bank, customer may withdraw cash through one of the two tellers at the counter. On average, one teller takes 3 minutes while the other teller takes 5 minutes to serve a customer. If the two tellers start to serve the customers at the same time, find the shortest time it takes to serve 200 customers.

(3 mks)

8. a) Expand and simplify the binomial expression $(2 - x)^7$ in ascending powers of x . (2mks)
- b) Use the expansion up to the fourth term to evaluate $(1.97)^7$ correct to 4 decimal places (2 mks)

9. The area of triangle FGH is 21 cm^2 . The triangle FGH is transformed using the matrix
- $$\begin{pmatrix} 4 & 5 \\ 1 & 2 \end{pmatrix}$$

Calculate the area of the image of triangle FGH (2 mks)

10. Simplify $\frac{\sqrt{3}}{\sqrt{3}-\sqrt{2}}$

$$\frac{\sqrt{3}}{\sqrt{3}-\sqrt{2}}$$

(2 mks)

11. A circle whose equation is $(x - 1)^2 + (y - k)^2 = 10$ passes through the point (2,5).

Find the coordinates of the two possible centres of the circle. (3

mks)

12. On a certain day, the probability that it rains is $\frac{1}{7}$. When it rains the probability that Omondi carries an umbrella is $\frac{2}{3}$. When it does not rain the probability that Omondi carries an umbrella is $\frac{1}{6}$. Find the Probability that Omondi carried an umbrella that day.

(2 mks)

13. Point P (40°S , 45°E) and point Q (40°S , 60°W) are on the surface of the Earth.

Calculate the shortest distance along a circle of latitude between the two points.

(3 mks)

14. Solve $4 - 4 \cos^2 \alpha = -1$ for $0^{\circ} \leq \alpha \leq 360^{\circ}$

(4 mks)

15. In the figure below, AT is a tangent to the circle at A $\angle \text{ATB} = 48^{\circ}$, $\text{BC} = 5 \text{ cm}$ and

$CT = 4 \text{ cm.}$

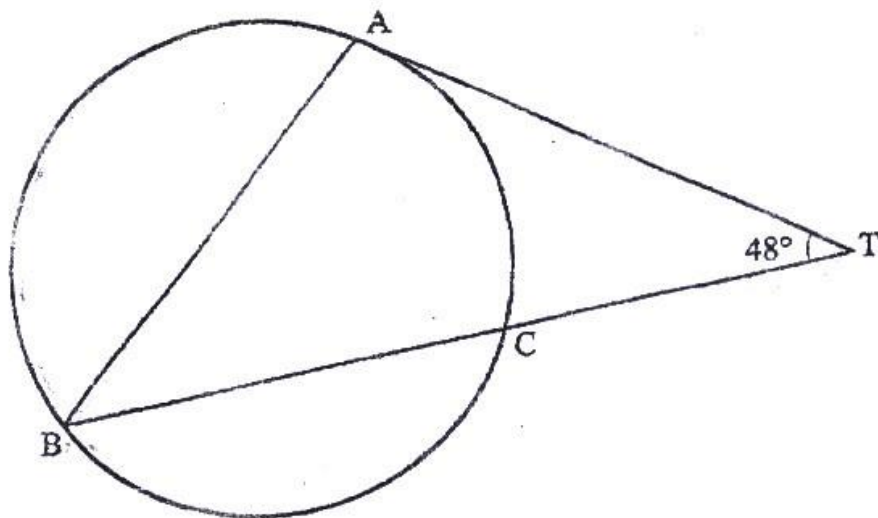

Calculate the length AT.

(2 mks)

16. A particle moves in a straight line with a velocity $V \text{ ms}^{-1}$. Its velocity after t seconds is given by $V = 3t^2 - 6t - 9$.

The figure below is a sketch of the velocity-time graph of the particle
Calculate the distance the particle moves between $t = 1$ and $t = 4$ (4 mks)

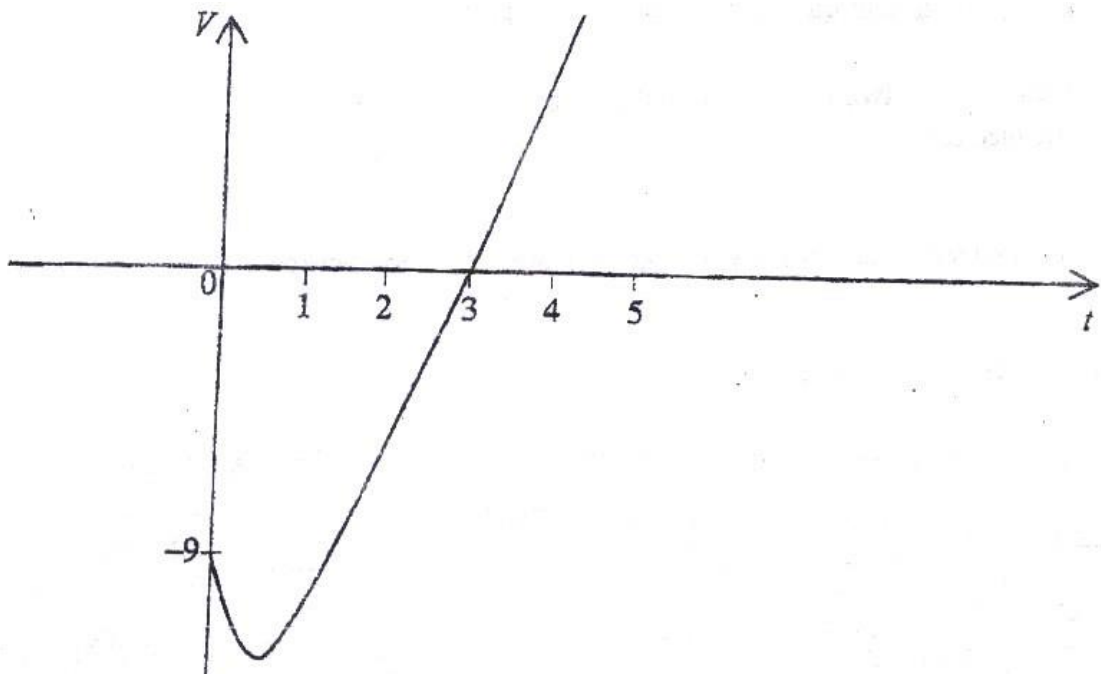

SECTION II (50 MKS)

Answer only five questions in this section in the spaces provided

17. A water vendor has a tank of capacity 18900 litres. The tank is being filled with water from two pipe A and B which are closed immediately when the tank is full.

Water flows at the rate of

- a) If the tank is empty and the two pipes are opened at the same time, calculate the time it takes to fill the tank. (3 mks)
- b) On a certain day the vendor opened the two pipes A and B to fill the empty tank. After 25 minutes he opened the outlet to supply water to his customers at an average rate of 20 Liters per minute
- i) Calculate the time it took to fill the tank on that day. (3 mks)
- ii) The vendor supplied a total of 542 jerricans, each containing 25 litres of water, on the day. If the water that remained in the tank was 6 300 litres, calculate, in litres, the amount of water that was wasted. (3 mks)
18. At the beginning of the year 1998, Kanyingi bought two houses, one in Thika and the other one Nairobi, each at Ksh 1 240 000. The value of the house in Thika appreciated at the rate of 12% p.a

- a) Calculate the value of the house in Thika after 9 years, to the nearest shilling. (2 mks)
- b) After n years, the value of the house in Thika was Kshs 2 741 245 while the value of the house in Nairobi was Kshs 2 917 231. (4 mks)
- i) Find n
- ii) Find the annual rate of appreciation of the house in Nairobi. (4 mks)

19. The table below shows the number of goals scored in handball matches during a tournament.

Number of goal	0-9	10-19	20-29	30-39	40-49

Number of matches	2	14	24	12	8
-------------------	---	----	----	----	---

Draw a cumulative frequency curve on the grid provided (5 mks)

b) Using the curve drawn in (a) above determine;

i) The median; (1 mk)

ii) The number of matches in which goals scored were not more than 37;

(1 mk)

iii) The inter-quartile range (3 mks)

20. Triangle PQR shown on the grid has vertices p(5,5), Q(10, 10) and R(10,15)

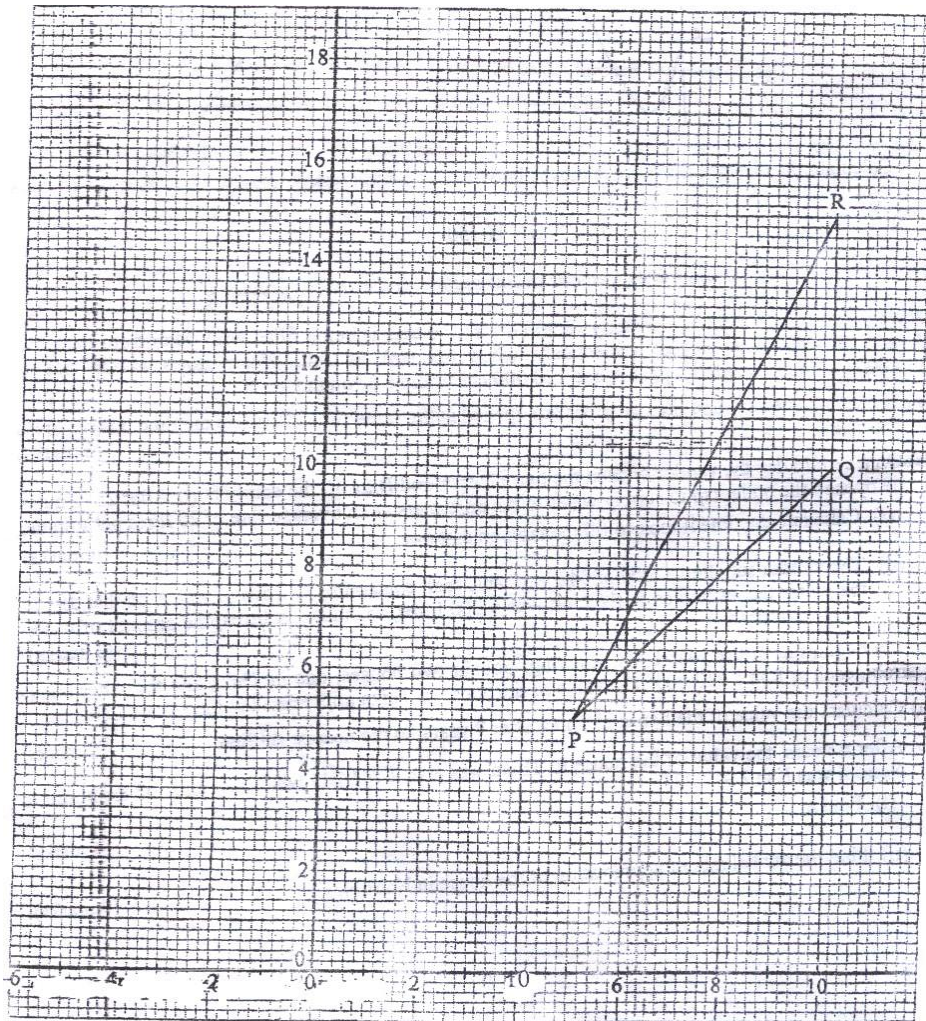

- a) Find the coordinates of the points P' , Q' and R' and the images of P, Q and R respectively under transformation M whose matrix is

0.8
$$= \begin{pmatrix} 0.6 & \\ & 0.6 \end{pmatrix}$$
 (2 mks)

- b) Given that M is a reflection;
- i) draw triangle $P'Q'R'$ and the mirror line of the reflection; (1 mk)

- ii) Determine the equation of the mirror line of the reflection (1 mk)
- c) Triangle $P''Q''R''$ is the image of triangle $P'Q'R'$ under reflection N is a reflection in the y -axis.
- i) draw triangle $P''Q''R''$
- ii) Determine a 2×2 matrix equivalent to the transformation NM (2 mks)
- iii) Describe fully a single transformation that maps triangle PQR onto triangle $P''Q''R''$ (2 mks)

21. The table below shows income tax rates.

Monthly income in Kenya shillings (Kshs)	Tax rate percentage (%) In each shilling
Up to 9 680	10
From 9681 to 18 800	15
From 18 801 to 27 920	20
From 27 921 to 37 040	25
From 37 041 and above	30

In certain year, Robi's monthly taxable earnings amounted to Kshs. 24 200.

a) Calculate the tax charged on Robi's monthly earnings. (4 mks)

b) Robi was entitled to the following tax reliefs:

I: monthly personal relief of Ksh 1 056;

II: Monthly insurance relief at the rate of 15% of the premium paid.

Calculate the tax paid by Robi each month, if she paid a monthly premium of

Kshs 2 400 towards her life insurance policy. (2 mks)

C) During a certain month, Robi received additional earnings which were taxed at 20% in each shilling. Given that she paid 36.3% more tax that month, calculate

the percentage increase in her earnings. (4

mks)

22. The figure below shows a right pyramid mounted onto a cuboid. $AB=BC= 15\sqrt{2}$ cm, $CG=$ and $VG = 17\sqrt{2}$ cm.

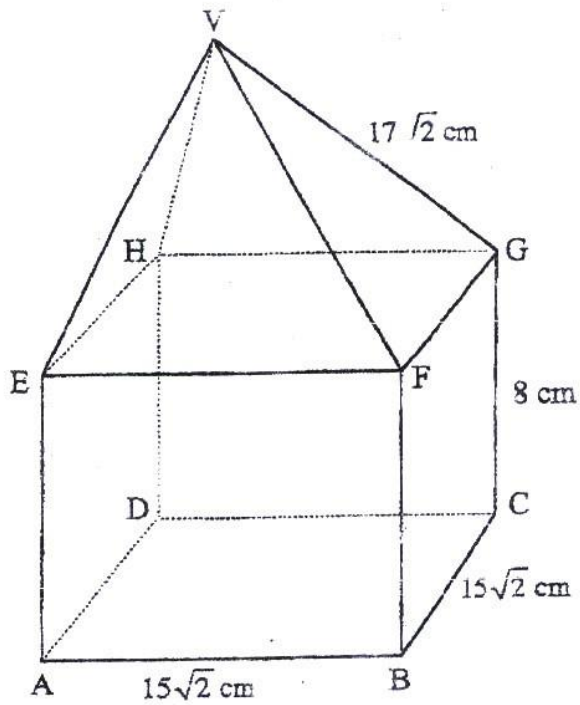

Calculate:

- The length of AC;
- The angle between the line AG and the plane ABCD;
- The vertical height of point V from the plane ABCD;
- The angle between the planes EFV and ABCD.

23. a) The first term of an Arithmetic Progression (AP) is 2. The sum of the first 8 terms of the AP is 156

i) Find the common difference of the AP. (2 mks)

ii) Given that the sum of the first n terms of the AP is 416, find n . (2mks)

b) The 3rd, 5th and 8th terms of another AP form the first three terms of a Geometric Progression (GP)

If the common difference of the AP is 3, find:

i) The first term of the GP; (4 mks)

ii) The sum of the first 9 terms of the GP, to 4 significant figures. (2mks)

24. Amina carried out an experiment to determine the average volume of a ball bearing. He started by submerging three ball bearings in water contained in a measuring cylinder. She then added one ball a time into the cylinder until the balls were nine..

The corresponding readings were recorded as shown in the table below

Number of ball bearings(x)	3	4	5	6	7	8	9
Measuring cylinder reading (y)	98.0	105.0	123.0	130.5	145.6	156.9	170.0

- a) i) On the grid provided, Plot (x, y) where x is the number of ball bearings and y is the corresponding measuring cylinder, reading.

(3 mks)

- ii) Use the plotted points to draw the line of best fit (1 mk)

- b) Use the plotted points to draw the line of best fit. (1 mk)

- i) The average volume of a ball bearing; (2 mks)

- ii) The equation of the line. (2 mks)

- c) Using the equation of line in b(ii) above, determine the volume of the water in the cylinder. (2 mks)

