

5.6 ELECTRICITY (448)

5.6.1 Electricity Paper 1 (448/1)

1. (a) **Institutions that train electrical technicians in Kenya:**

- University colleges
- Institutes of technology
- Technical training institutes
- Vocational Training centres
- National polytechnics

Any $4 \times \frac{1}{2} = 2$ marks

(b) **Components of a business plan:**

- (i) Business description
- (ii) Organisation/ management plan
- (iii) Marketing plan
- (iv) Production/ operation plan
- (v) Financial plan

Any $4 \times \frac{1}{2} = 2$ marks

2. (a) **Disposal of electrical waste materials**

- Lead acid battery - return to the manufacturer.
- Fluorescent tube - break and bury.

$2 \times \frac{1}{2} = 1$ mark

(b) **Use of extinguishers**

Water - to put out fires on burning solid materials

Foam - to put out fires on burning oils and chemicals

Dry powder - used to deal with fires on burning flammable liquids and some solids as wood and paper.

3. (a) Value of resistor = 680Ω (1 mark) $\pm 20\%$ (1 mark)

(b) Maximum current $I = \sqrt{\frac{P}{R}}$ 1 mark

$$P = 1 \text{ W}$$

$$I = \sqrt{\frac{1}{680.68}} \quad \frac{1}{2} \text{ mark}$$

$$= \sqrt{\frac{1}{544}} \quad \frac{1}{2} \text{ mark}$$

$$= 42.87 \text{ Amps}$$

1 mark
5 marks

4. (a) Lenz's law of electromagnetic induction states that the direction of an induced emf is always such that it tends to set up a current opposing the motion or change of flux responsible for inducing that emf.

- (b) **Characteristics of magnetic lines of force.**
- They have a direction from north to south poles.
 - They form complete loops.
 - They do not cross each other.

Any 2 x 1 = 2 marks

5. (a) Sensitivity is the amount of current $\frac{1}{2}$ required to provide full scale $\frac{1}{2}$ deflection of the pointer. (1 mark)

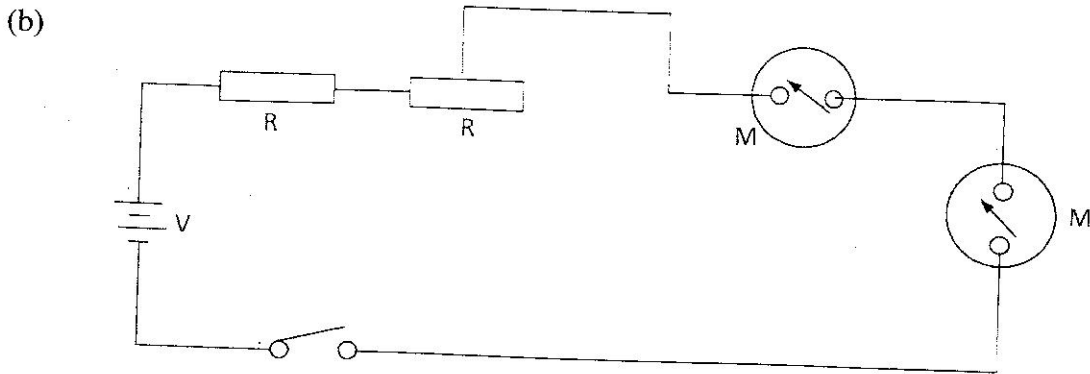

Figure 1

Components $6 \times \frac{1}{2} = 3$ marks
 Series connection = 1 mark
 4 marks

6. (a) **Armature reaction:** This refers to the distortion of $\frac{1}{2}$ the main magnetic field of a d.c generator by the magnetic field created by a generated $\frac{1}{2}$ current $\textcircled{1}$ around the conductor.

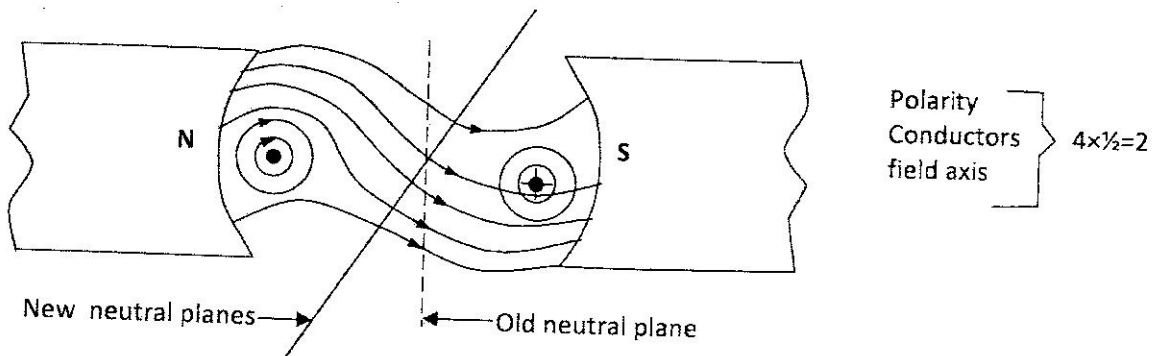

Figure 2

OR

Armature reaction changes the neutral plane of the main field such that it becomes $\textcircled{1}$ irregular. This causes arcing between the brushes and the commutator and also $\textcircled{1}$ lowers generator output. (4 marks)

(b) **Methods of reducing Reaction:**

- Adjusting the brushes to the new neutral plane.
 - Use of interpoles between main field poles to cancel its effect.
 - Use of compensating windings in series with the armature to counter its effects.
- Any 2 x 1 = 2 marks

7. (a) Intrinsic semiconductor is made of semiconductor material in its pure form. Extrinsic semiconductor is intrinsic semiconductor to which some suitable impurity or doping agent has been added in small amounts. (3 marks)

Examples are:

Intrinsic -

Extrinsic -

(b) **Uses of ohmmeter in trouble shooting**

- To check short circuits
- To test open circuits
- To ascertain polarity of diodes and transistors
- To measure values of resistors.

$4 \times \frac{1}{2} = 2$ marks

8. (a) **Conductor materials used in electric circuits**

- Copper
- Aluminium
- Silver
- Brass
- Gold
- Steel
- Mercury

Any 4 x $\frac{1}{2}$ = 2 marks

(b) **Advantages of MIMS over PVC cables**

- They require no further protection/ mechanically stronger
- They are impervious to oil
- They last longer
- They have better heat resistance

Any 2 x 1 = 2 marks

9. (a) (i) \therefore current through $C_1 R_3 = I_t - I_4$
 $= 1.8 - 1.2 = 0.6 \text{ A}$ $\left(\frac{1}{2}\right)$

$$\therefore \text{p.d across } R_3 = I_3 \times R_3$$

$$= 0.6 \times 50$$

$$= 30 \text{ V. } \textcircled{1}$$

AWARD FULL MARKS FOR CORRECT ALTERNATIVE METHOD.

$$(ii) \quad I_t = \frac{V}{R_t}$$

$$R_t = R_1 + (R_2 + R_3) // R_4 \quad \left(\frac{1}{2}\right)$$

$$R_2 + R_3 = 50 + 50 = 100 \Omega$$

$$100\Omega // R_4 = \frac{100 \times 50}{100 + 50} = \frac{5000}{150} = 33.3 \Omega \quad \left(\frac{1}{2}\right)$$

$$\begin{aligned} \therefore R_t &= R_1 + 33.3 \Omega \\ &= 100 + 33.3 = 133.3 \Omega \end{aligned}$$

$$I_t = \frac{V}{R_t} = \frac{240}{133.3}$$

$$= 1.8 \text{ A}$$

b) (i) $I_t = I_3 + I_4$

$$V_4 = 240 - I_t R_1 = 240 - 180 = 60 \text{ V}$$

$$\therefore \text{p.d across } R_4 = 60 \text{ V}$$

(ii) P.d across $R_4 = \text{P.d across } R_2 + R_3$

$$\text{Current through } R_4 = \frac{V_4}{R_4} = \frac{60 \text{ V}}{50 \Omega}$$

$$I_4 = 1.2 \text{ A}$$

10. (a) Marking out tools
- Scriber
 - Try square
 - Centre punch
 - Steel rule
 - Calliper

Any 4 x $\frac{1}{2}$ = 2 marks

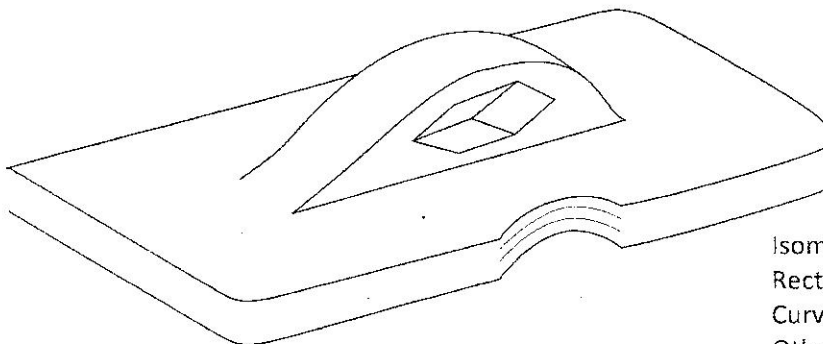

Figure 3

- Isometric view with N lowest = 1mark
- Rectangular base = 1mark
- Curved upper part = 1mark
- Other features = 1mark
- 4marks

11. (a) (i) 41 ten to binary

Divide 2 41

2 20 - 1

2 10 - 0

2 5 - 0

2 2 - 1

1 - 0

Correct method = 1

Correct answer = 1

= 101001₂

2 marks

(ii) 1101101₂ to decimal

2⁶ 2⁵ 2⁴ 2³ 2² 2¹ 2⁰

1 1 0 1 1 0 1

64 + 32 + 0 + 8 + 4 + 0 + 1

Correct method = 1

Correct answer = 1

= 109₁₀

2 marks

(b) (i) A logic gate is an elementary building block of a digital circuit. Most logic gates have two inputs and one output.

(i)

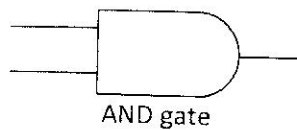

AND gate

(ii)

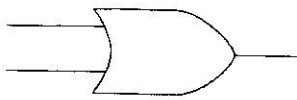

OR gate

3×1=3 Marks

(iii)



NAND gate

Figure 4

(c) NAND gate

Input 1	Input 2	Output
0	0	1
0	1	1
1	0	1
1	1	0

Input $2 \times \frac{1}{2} = 1$ mark

Output $4 \times \frac{1}{2} = 2$ marks

NOR gate

Input 1	Input 2	Output
0	0	1
0	1	0
1	0	0
1	1	0

Input $2 \times \frac{1}{2} = 1$ mark

Output $4 \times \frac{1}{2} = 2$ marks

12. (a) **Advantages**

- Size is smaller for a given kilo-volt - ampere rating
- The core is more rigid
- They are cheaper
- Lower in iron losses at higher densities

Any 3 x 1 = 3 marks

(b) **Assumptions**

- No core losses
- Windings have negligible resistance
- All the flux produced links the primary and the secondary
- Negligible emf is required to set up the flux as the core permeability is very high

Any 3 x 1 = 3 marks

(ii) (I) Ideal transformer has no losses

$$E_1 = V_1 = 5000 \text{ V} \quad \left(\frac{1}{2}\right)$$

$$E_2 = V_2 = 500 \text{ V} \quad \left(\frac{1}{2}\right)$$

$$\text{Turns Ratio} = \frac{E_1}{E_2} = \frac{N_1}{N_2} = \frac{5000}{500} = 10 \quad (1)$$

$$\therefore \frac{N_1}{N_2} = 10 \Rightarrow N_1 = 10 \times N_2 \quad \left(\frac{1}{2}\right)$$

$$\begin{aligned} N_1 &= 10 \times 40 \\ &= 400 \text{ turns} \quad (1) \end{aligned}$$

$$(II) \quad I_1 V_1 = \text{VA (input)} \quad \textcircled{\frac{1}{2}}$$

\therefore Primary full load current (I_1)

$$= \frac{\text{kVA}}{V_1} = \frac{10 \times 10^3}{5000} \quad \textcircled{\frac{1}{2}}$$

$$= 2 \text{ A} \quad \textcircled{\frac{1}{2}}$$

$$(III) \quad I_2 V_2 = \text{VA (output)} \quad \textcircled{\frac{1}{2}}$$

\therefore Secondary full-load current (I_2)

$$= \frac{\text{kVA}}{V_2} = \frac{10 \times 10^3}{500} \quad \textcircled{\frac{1}{2}}$$

$$= 20 \text{ A} \quad \textcircled{\frac{1}{2}}$$

TOTAL = 7 marks

13. (a) (i) Current and voltage are in phase. (1 mark)

(ii) Current lags voltage. (1 mark)

(b) (i) $X_L = 2\pi fL$ (1)

$$= 2\pi \times 50 \times 0.4 \quad \textcircled{\frac{1}{2}}$$

$$= 125.6 \Omega \quad \textcircled{\frac{1}{2}}$$

(ii) $X_C = \frac{1}{2\pi fc}$ (1)

$$= \frac{1}{2 \times 3.14 \times 50 \times 50 \times 10^{-6}} \quad \textcircled{\frac{1}{2}}$$

$$= 63.7 \Omega \quad \textcircled{1}$$

(iii) Z (impedance) = $\sqrt{R^2 + (X_L - X_C)^2}$ (1)

$$= \sqrt{50^2 + (125.7 - 63.7)^2} \quad \textcircled{\frac{1}{2}}$$

$$= 79.6 \Omega \quad \textcircled{1}$$

(iv) Current $I = \frac{V}{Z}$ (1)

$$= \frac{240}{79.6} \quad \textcircled{\frac{1}{2}}$$

$$= 3 \text{ A} \quad \textcircled{\frac{1}{2}}$$

$$\begin{aligned}
 \text{(v) Power (P)} &= I^2 R \\
 &= 3^2 \times 50 \\
 &= 450 \text{ W}
 \end{aligned}$$

TOTAL = 11 marks

SECTION B

14. (a) (i) **IEE requirements**

- Must be double - wound
- Should be earthed at one point of secondary winding iron-core of transformer and metal casing
- Should have a separate control switch and connected on its own final circuit
- Should have a high grade insulation of supply cable to transformer

Any 2 x 1 = 2 marks

(ii) **Advantages of MCB**

- Easy to reset therefore replacement not necessary
- Gives better overall protection against fire and shock
- Cannot be replaced by an inexperienced person
- Highly discriminative
- Sustained overload and reject harmless transient overcurrent.

Any 2 x 1 = 2 marks

(b) **Insulation resistance test**

- Set the ohmmeter/megger to a suitable range.
Ensure the following:
 - the main supply is disconnected
 - all switches are on ON position
 - all MCB are on ON position
 - all loads e.g. bulbs are in position or join conductors where there's no load
- Connect the ohmmeter/megger between live and neutral terminals with earth terminal.
- Carryout the resistance test.
- Get the required readings.
- Repeat the procedure by taking measurements between the L and N conductors
- The reading should not be below/ mega ohm.

9 x 1 = 9 marks

15. (a)

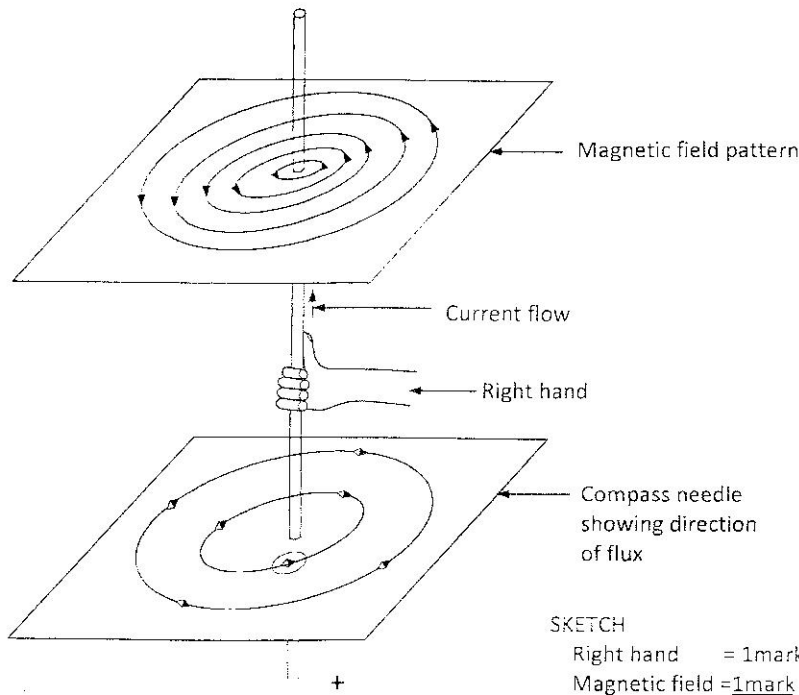

SKETCH
 Right hand = 1mark
 Magnetic field = 1mark
 2Marks

Figure 5

When conductor is gripped with right hand:
 Thumb points in direction of current
 Fingers point in direction of magnetic field } ①

(3 marks)

(b)

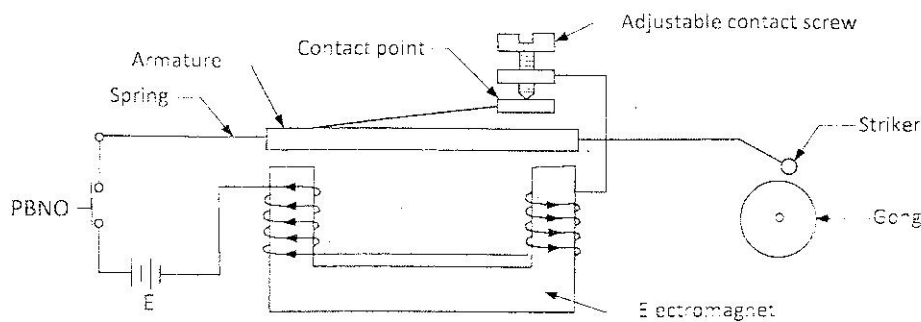

Figure 6

SKETCH
 Correct circuit = 2mark
 Labelling any 6x½ = 3mark
 5Marks

- When the push button is pressed, current flow through the circuit. ①
- The coils become energized and attracts the armature and the striker hits the gong. ① This movement of the armature away from the contact - screw breaks the circuit. ①
- The coils are denenergized and the armature falls back to its original position and its circuit is completed once again. ①
- The sequence of movements recurs causing a continuous ringing/trembling sound. ①