

3.22 AVIATION TECHNOLOGY (450)

3.22.1 Aviation Technology Paper 1 (450/1)

SECTION A (44 marks)

Answer all questions in this section.

- 1 (a) Differentiate between class **B** and **C** types of fire. (2 marks)
- (b) State the type of fire extinguishing agents used for each of the following classes of fire.
- (i) Class **C**
- (ii) Class **D**
- (2 marks)
- 2 Outline **three** roles of aircraft dispatchers. (3 marks)
- 3 Explain **four** measuring instruments used by meteorologists. (4 marks)
- 4 (a) State **two** advantages of using blind rivets. (2 marks)
- (b) Explain the reason why structural screws are used for joining aircraft parts. (1 mark)
- 5 (a) Differentiate between profile drag and induced drag. (2 marks)
- (b) Sketch airflow pattern over each of the following body shapes
- (i) Flat plate
- (ii) Stationary cylinder
- (iii) Streamlined. (3 marks)
- (c) Describe the behaviour of “Boundary layer” on an aircraft wing in flight. (2 marks)
- 6 (a) Differentiate between non-destructive and destructive testing. (2 marks)
- (b) Define each of the following terms as applied in aircraft structures:
- (i) fuselage;
- (ii) cockpit.
- 7 Distinguish between a wet sump and dry sump aeropiston oil lubricating system. (6 marks)

- 8** (a) Outline the meaning of each of the four range colour markings on aircraft instruments. (4 marks)
- (b) Give **two** aircraft instruments controlled by gyroscopes. (1 mark)
- 9** (a) Explain how each of the following tools are used during fabrication of aircraft parts.
- (i) Bucking bars;
- (ii) Countersink bit. (2 marks)
- (b) State **two** reasons for removing paint on an aircraft part. (2 marks)
- 10** Sketch the following drawing symbols: (4 marks)
- (a) Machined surface
- (b) Long break line
- (c) Ohmmeter
- (d) Transformer

- 13** (a) Outline **three** advantages of plastics over metals in aircraft construction. (3 marks)
- (b) Explain **five** selection criteria for aircraft engine bolts. (5 marks)
- (c) Outline the procedure of making a through M10 threads on a 10mm mild steel plate. (6 marks)
- 14** (a) Explain **four** functions of aircraft tabs during flight. (4 marks)
- (b) With the aid of labelled sketches, describe the operation of each of the following aircraft tabs to effect pitching moments.
- (i) Servo
- (ii) Trim (10 marks)
- 15** (a) Define each of the following terms as applied to Aviation industry. (2 marks)
- (i) Indicated airspeed.
- (ii) Ground speed.
- (b) Explain the function of each of the following aircraft electrical safety devices. (3 marks)
- (i) Magnetic indicators.
- (ii) Circuit breakers.
- (iii) Weight switch.
- (c) With the aid of a labelled sketch, explain the principle of electrical power generation of an aircraft. (9 marks)

STATION 1

INSTRUCTIONS

Figure 1 shows the exploded view of light aircraft single disc brake assembly.

On the drawing paper provided:

- (a) Sketch in good proportion a pictorial view of the assembled unit. (7 marks)
- (b) Name the six parts labelled 1, 2, 3, 4, 5 and 6. (3 marks)

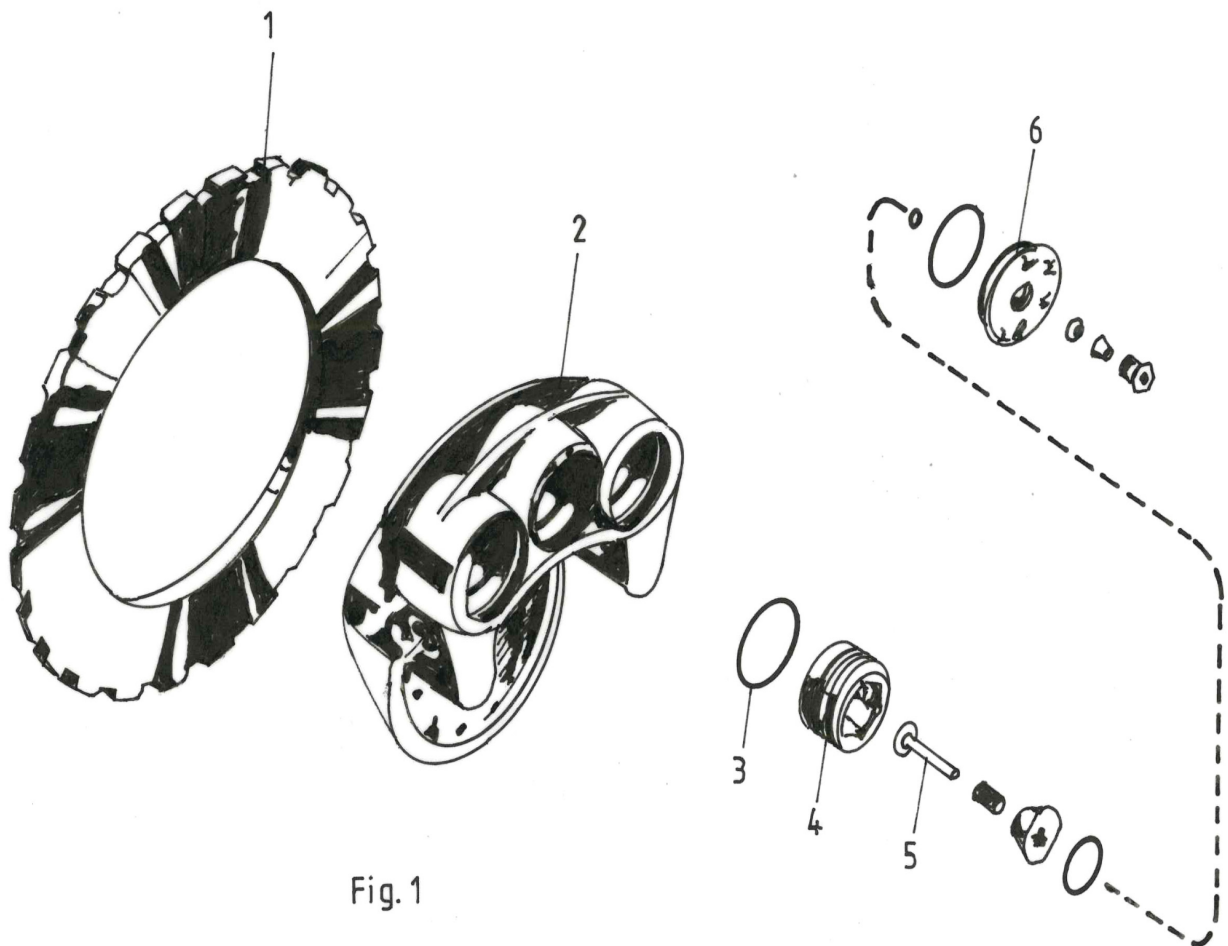

Fig. 1

STATION 2

INSTRUCTIONS

Using the tools, materials and equipment provided, make an aircraft panel hinge shown in figure 2. (10 marks)

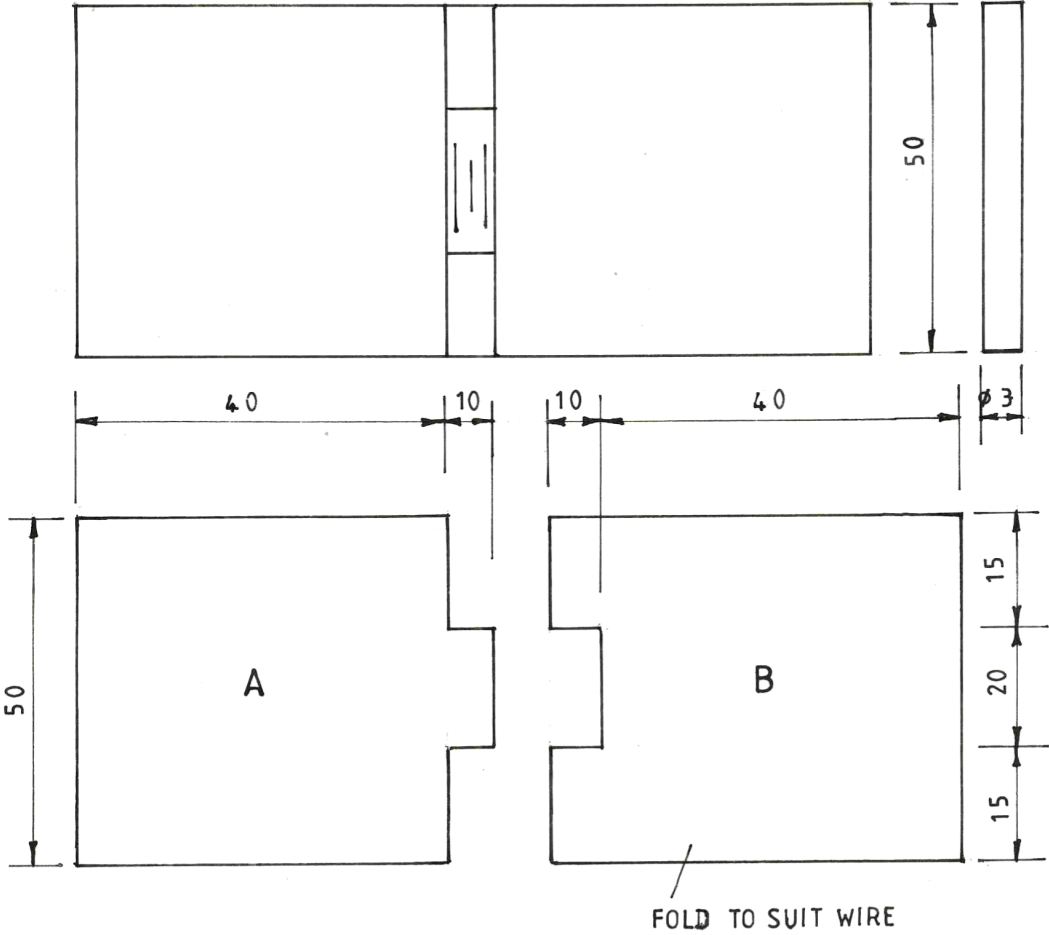

Fig. 2

STATION 3

INSTRUCTIONS

Using the Bunsen burner, materials and tools provided carry out the following

- (a) (i) Hold the piece marked K on the Burner and observe as it burns and fill the table below.
(ii) Repeat a(i) on the piece marked L.

	Observation	Material	Application
K			
L			

(3 marks)

- (b) Using the materials and tools provided, carry out the following.
Centre punch each of the materials marked M and N and fill the table below.

	Mark Observation	Material	Application
M			
N			

(3 marks)

- (c) Identify each of the following aircraft breakdown spares labelled P and R and fill the table below.

	Spare	Use	Probable fault	Maintenance Requirement
P				
R				

(4 marks)

SECTION 4

INSTRUCTIONS

Study the aircraft component and do the following:

- (a) (i) Identify the component and state its function.
- (ii) Remove the circlip. Let the examiner check your work.
- (iii) Name the parts painted Red, Blue and Yellow and state the function of each.

Name	Function
Red
Blue
Yellow

- (iv) Observe two defects on the parts and state the effect of each.

Defect	Effect
.....

- (v) Assemble the component.
Let the examiner check your work. (8 marks)

- (b) (i) Explain how the component is operated.
- (ii) Give the major maintenance task on the component. (2 marks)

STATION 5

INSTRUCTIONS

Study the components labelled A, B and C and carry out the following

- (a)
- (i) Identify the components
 - (ii) State the type
 - (iii) State the condition
 - (iv) State the use.

Component	Identification	Type	Condition	Use
A				
B				
C				

(6 marks)

- (b) Study the aircraft fuel system components labelled D and E and do the following:

- (i) Identify the parts.

D

E

- (ii) State where each is used.

D

E

- (iii) State **two** maintenance requirements.

- (iv) State **two** rejection criteria.

(4 marks)

STATION 6

INSTRUCTIONS

Study the aircraft tyre provided and do the following

- (a) Identify the tyre defects labelled A to E, state the cause of each on an aircraft and complete the table below.

ITEM	DEFECT	PROBABLE CAUSE
A		
B		
C		
D		
E		

(5 marks)

- (b) State the importance of the parts marked White and Blue.

White

Blue

(2 marks)

- (c) Give **three** manufacturer's specifications on the tyre and the meaning of each.

1

2

3

(3 marks)

STATION 7

INSTRUCTIONS

Study the markings on aircraft model labelled X and Y provided, representing imaginary arrangement of lines of forces according to aircraft design and do the following:

- (a) determine the correct arrangement of the lines of forces;

.....
.....

(1 mark)

- (b) identify each of the lines on the correct arrangement and give reasons;

1
2
3
4

(4 marks)

- (c) name points 5, 6 and 7 and state reason for the position of each;

5
6
7

(3 marks)

- (d) give **two** advantages of the correct arrangement;

.....

STATION 8

INSTRUCTIONS

The pilot for aircraft marked “A” has been cleared to taxi and encounters each of the scenarios 1ST, 2ND, 3RD, 4TH and 5TH as shown on the airfield plan provided.

Study each scenario and in the table below state the expected immediate action and reason for the action. (10 marks)

SCENARIOS	IMMEDIATE ACTION	REASON FOR THE ACTION
1 ST		
2 ND		
3 RD		
4 TH		
5 TH		

STATION 9

INSTRUCTIONS

- (a) Connect the components as shown in figure 3.
Let examiner check your work.

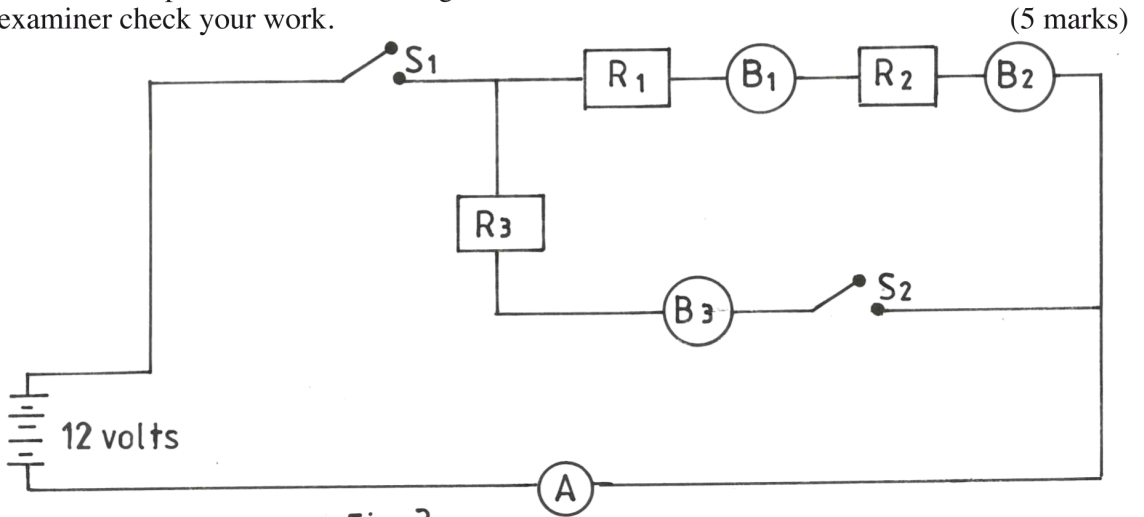

Fig. 3

- (b) (i) Close switch S_1 and S_2 and state what happens.
 (ii) Select switch S_2 to off position and state what happens.
 (iii) State the reasons behind your observations in b(i) and b(ii).

Reasons for observation in b(i)

Reasons for observation in b(ii)

(4 marks)

- (c) State **one** application of each of the circuit modes in a(i) and a(ii).

(1 mark)

STATION 10

INSTRUCTIONS

Study the four stroke engine component provided and do the following:

- (a) (i) identify the component.
 (ii) state the material used for its manufacture.
 (iii) name type of gear.
 (iv) record the number of teeth.

(2 marks)

(b) Measure and record each of the following:

- (i) diameter of the journal labelled A.
- (ii) height of the lobe labelled B.
- (iii) distance between lobes B and C.
- (iv) the angle of the lobe labelled B.

4 marks)

(c) Give the functions of:

- (i) component
- (ii) areas painted

Blue

Red

Yellow

(2 marks)

(d) Name **two** maintenance aspects and two possible faults:

- (i) Maintenance aspects.
- (ii) Possible faults.

(2 marks)