

3.7 GENERAL SCIENCE (237)

3.7.1 General Science Paper 1 (237/1)

SECTION A: BIOLOGY (34 marks)

Answer *all* the questions in this section in the spaces provided.

- 1 (a) State **one** precaution that should be observed to protect bench tops when performing laboratory experiments. (1 mark)
- (b) State the importance of transport in plants. (3 marks)
- (i)
- (ii)
- (iii)

2 The diagram below represents a terrestrial plant.

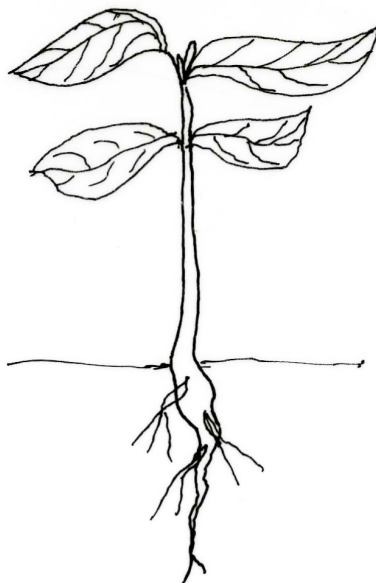

Based on the observation of the diagram:

- (a) state the class to which the plant belongs; (1 mark)
- (b) give a reason for your answer in 2(a) above. (1 mark)

- 3 A strip of raw pawpaw measuring 3 cm in length was immersed in a beaker of water. After 30 minutes the strip measured 3.2 cm.
- (a) Explain the change in length. (2 marks)
- (b) State **one** other observation that was made on the raw pawpaw strip at the end of the experiment. (1 mark)

- 4 The diagram below represents a plant cell as seen under high power of the light microscope.

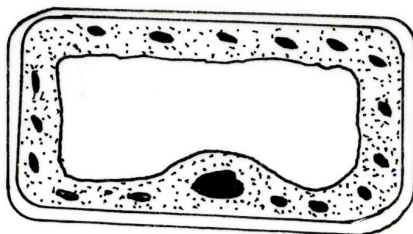

- (a) Based on observations of the diagram, give **three** reasons why it is a plant cell. (3 marks)
- (b) Name the organelle that carries out autotrophic nutrition in plants. (1 mark)
- 5 (a) Give a reason in each case why enzymes are:
- (i) catalysts; (1 mark)
- (ii) denatured by high temperatures. (1 mark)
- (b) Explain the effect of temperature on the rate of photosynthesis. (2 marks)
- 6 (a) State **two** reasons for carrying out vaccination. (2 marks)
- (b) What is an allergic reaction? (1 mark)
- 7 (a) Explain how age affects the rate of breathing in human beings. (2 marks)
- (b) Name the causative agent of pulmonary tuberculosis. (1 mark)

- 8 (a) The diagrams below represents an experimental set-up that was used to investigate the process of respiration.

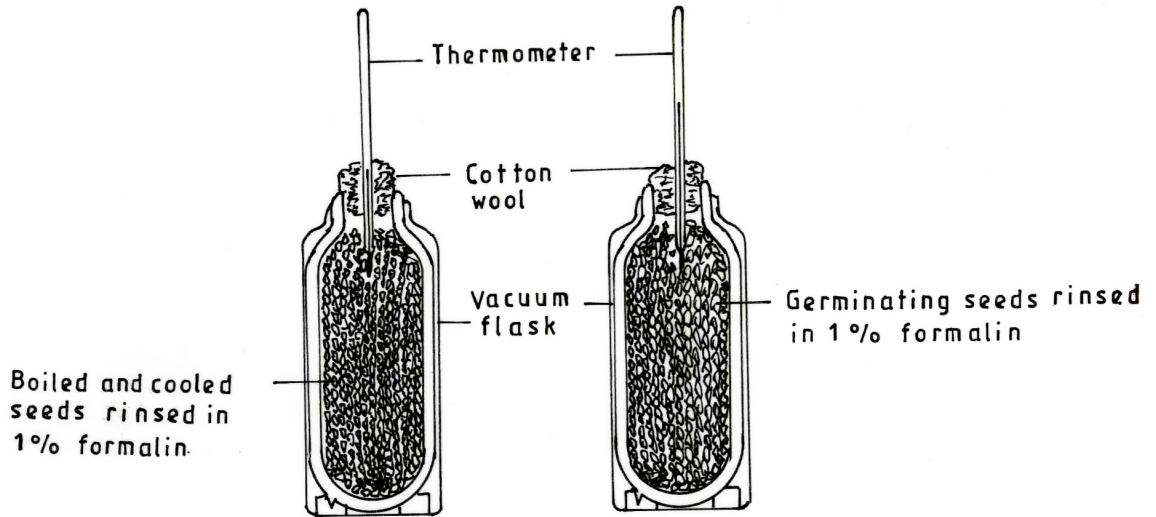

- (i) State the aim of the investigation. (1 mark)
- (ii) State the purpose of rinsing the seeds in 1% formalin. (1 mark)
- (b) Name **two** end products of digestion of a meal consisting of boiled rice and beans without oil. (2 marks)
- 9 (a) Apart from thermoregulation, state **two** other roles of the skin in homeostasis. (2 marks)
- (b) How does amoeba maintain osmotic pressure when placed in hypotonic solution? (2 marks)
- 10 How is the liver involved in thermoregulation? (3 marks)

SECTION B: CHEMISTRY (33 Marks)

Answer *all* the questions in this section in the spaces provided.

- 11** An experiment was set up to investigate the products of a burning candle as shown in the diagram below.

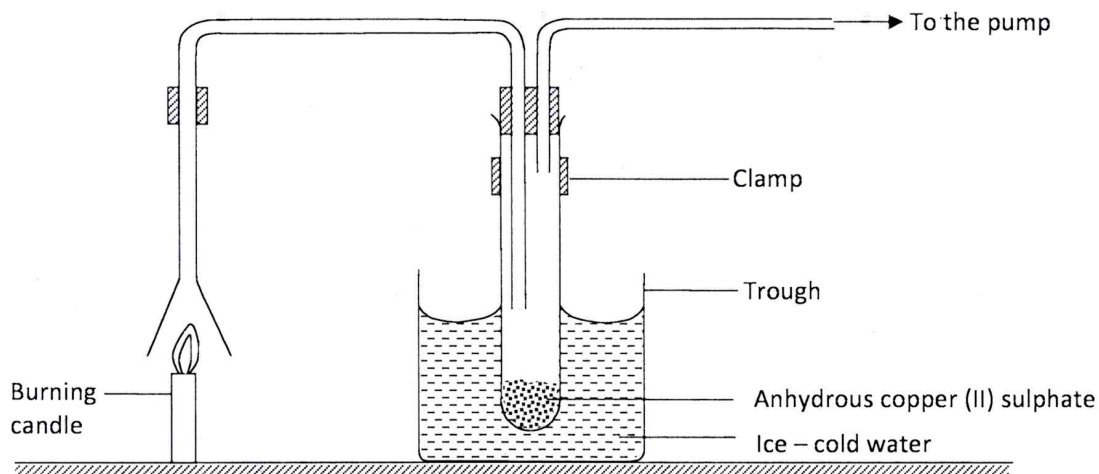

- (a) (i) State an observation made on the anhydrous copper (II) sulphate. (1 mark)
- (ii) Explain the observation made in a(i) above. (1 mark)
- (b) What effect does the other product of burning candle have on the environment? (1 mark)

- 12 The diagram below is a set-up for the laboratory preparation of oxygen gas.

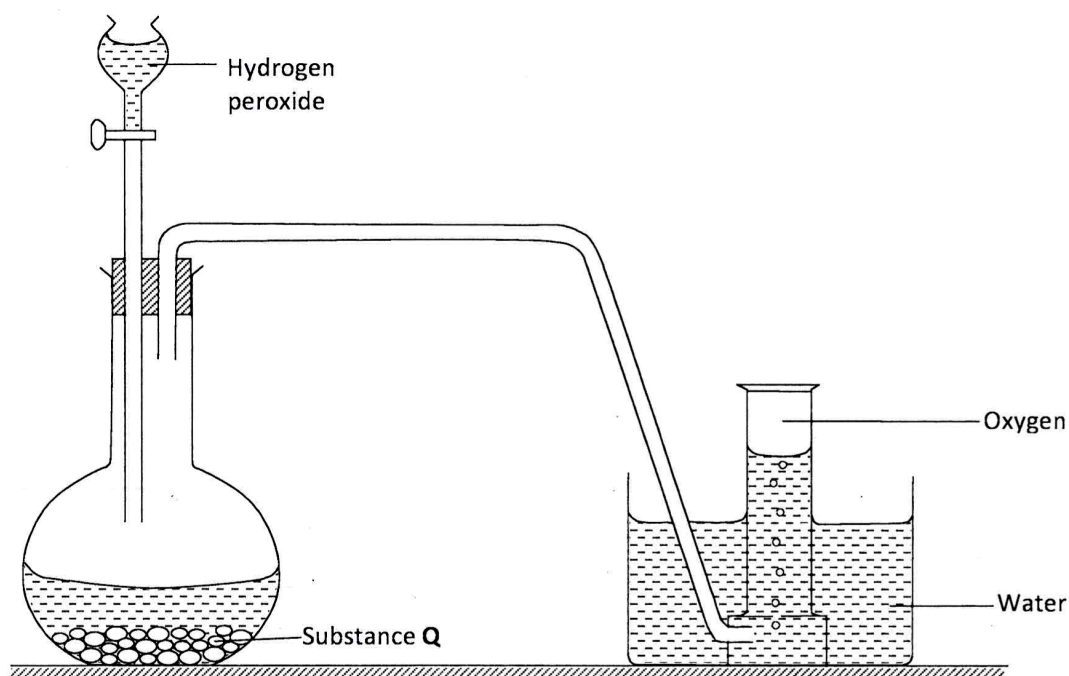

- (a) Name substance Q. (1 mark)
- (b) Write an equation for the reaction that produces oxygen gas. (1 mark)
- (c) Name **two** other reagents which can be used to prepare oxygen in the laboratory. (1 mark)
- (d) Describe a laboratory test to show that the gas produced is oxygen. (1 mark)

- 13 The table below shows the pH values of solutions.

Solution	M	N	O	P
pH	2	7	12	14

- (a) Which solution is likely to be calcium hydroxide? (1 mark)
- (b) Name the products formed when solution M reacts with sodium carbonate. (1 mark)
- 14 (a) (i) What is meant by the term “**hygroscopic salt**”? (1 mark)
- (ii) Give **one** example of an hygroscopic salt. (1 mark)
- (b) State **one** use of sodium chloride other than being a food additive. (1 mark)

- 15 A student set up an experiment to investigate the effect of passing an electric current through lead (II) bromide using graphite electrodes as shown below.

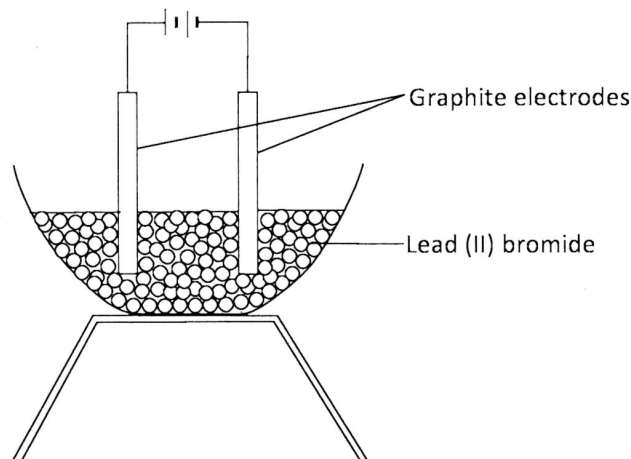

- (a) Identify a mistake in the set-up. (1 mark)
- (b) Name the product formed at the anode after the mistake was corrected. (1 mark)
- 16 (a) Hard water is healthy for drinking. Explain. (1 mark)
- (b) Explain how ion-exchange is used to remove hardness in water. (2 marks)
- 17 A student used paper chromatography to separate pigments in different inks and obtained the results shown in the diagram below.

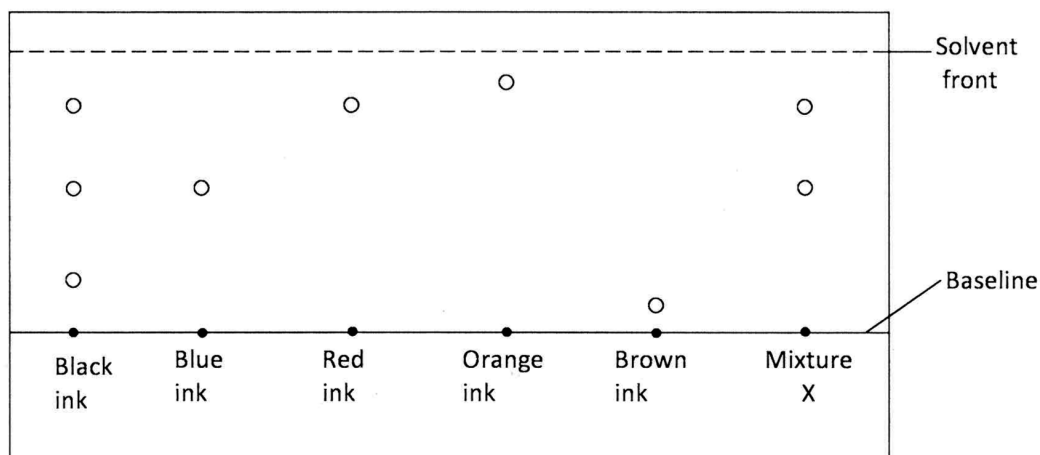

- (a) Identify the inks that are in X. (1 mark)
- (b) Which of the inks is **least** soluble? (1 mark)
- 18 Describe how sodium chloride can be obtained from a mixture of sulphur powder and sodium chloride. (3 marks)

19 (a) What is meant by the term “ionization energy”? (1 mark)

(b) Study the following table and use it to answer the questions that follow. The letters do not represent the actual symbols of the elements.

Element	P	Q	R	S	T	U	V	W
Electronic configuration	2.8.1	2.8.2	2.8.3	2.8.4	2.8.5	2.8.6	2.8.7	2.8.8
1st ionization energy (kJ mol ⁻¹)	494	736	576	787	1017	1000	1255	1519

(i) From the table, ionization energies increase generally from element P to element W. Explain. (2 marks)

(ii) What types of oxides are formed by elements:

(I) R($\frac{1}{2}$ mark)

(II) U($\frac{1}{2}$ mark)

20 The table below shows the atomic numbers of elements of the periodic table represented by letters A to H. The letters are not the actual symbols of the elements.

Element	A	B	C	D	E	F	G	H
Atomic Number	3	7	8	9	10	11	12	13

(a) Select from the table **two** elements that belong to the same group. (1 mark)

(b) Write the formula of a compound formed between elements H and C. (1 mark)

(c) Which of the elements is monoatomic? (1 mark)

(d) Select an element that forms a divalent cation. (1 mark)

21 (a) Identify the types of bonds in carbon (II) oxide molecule. (1 mark)

(b) Explain why graphite is used as a lubricant. (2 marks)

SECTION C: PHYSICS (33 marks)

Answer **all** the questions in this Section in the spaces provided.

- 22 A stopwatch showed a reading of 0.05 s before the start button was pressed. When this stopwatch was used to measure the time taken by a stone to drop from the top of a building to the ground it recorded 3.68 s. Determine the time of fall. (2 marks)
- 23 Define the term density. (1 mark)
- 24 An object is found to have a weight of 12.5 N at a place where the acceleration due to gravity is 10 ms^{-2} . Determine the mass of the object. (3 marks)
- 25 Explain how a drinking straw is used to draw a liquid from a bottle into the mouth. (3 marks)
- 26 State the reason why it is possible to compress a gas but not a liquid. (1 mark)
- 27 (a) Overhead power cables between posts are allowed to sag a bit. Explain why this is necessary. (2 marks)
- (b) **Figure 1** shows a bimetallic strip made of brass and iron.

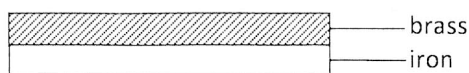

Figure 1

In the space below, draw the appearance of the strip when heated (*brass expands more than iron*). (1 mark)

- 28 Define the term heat energy. (2 marks)
- 29 **Figure 2** shows a uniform metre rule pivoted at the 20 cm mark and balanced by a weight of 4.5 N.

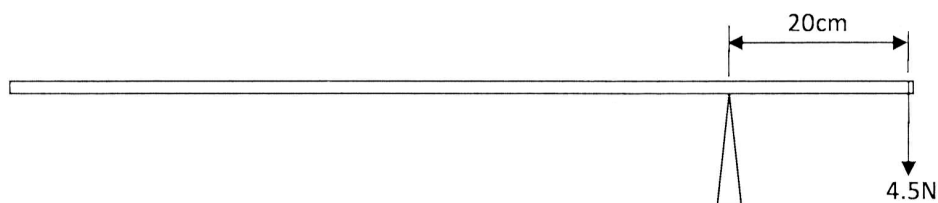

Figure 2

Determine the weight of the rule. (3 marks)

30 **Figure 3** shows a cone resting on a flat surface.

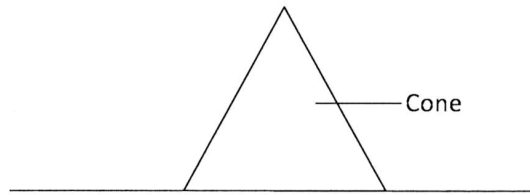

Figure 3

- (a) Name the state of equilibrium of the cone. (1 mark)
- (b) State the reason for the answer in (a) above. (1 mark)

31 **Figure 4** shows a velocity - time graph for the motion of a certain body.

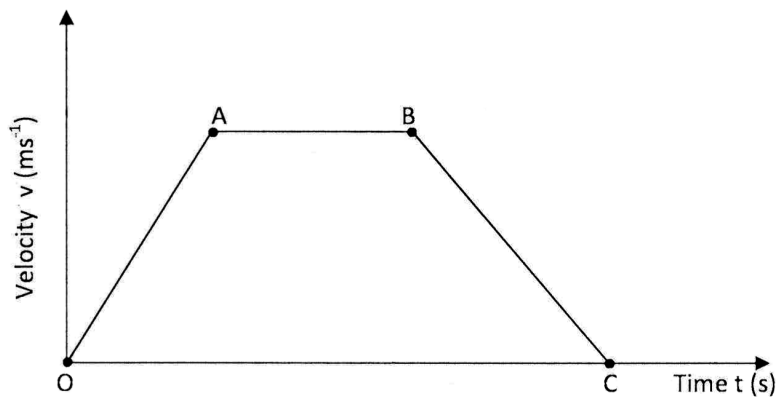

Figure 4

Describe the motion of the body in the region:

- (a) OA; (1 mark)
 - (b) AB; (1 mark)
 - (c) BC. (1 mark)
- 32 The length of a spring is 20 cm. When it is used to support a mass of 0.4 kg, its new length is 20.8 cm. Determine the spring constant. (*take acceleration due to gravity $g = 10 \text{ ms}^{-2}$*) (3 marks)
- 33 It is observed that a passenger standing in a stationary truck tends to fall in a direction opposite to the motion of the truck when it suddenly starts moving. Explain this observation. (2 marks)

- 34 **Figure 5** shows a cork floating in water and held in position by a thin thread attached to the bottom of the container.

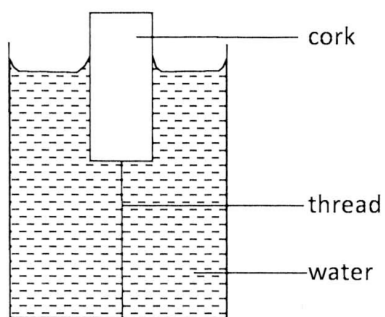

Figure 5

- Name **three** forces acting on the cork. (3 marks)
- 35 State the energy changes that take place when a torch is switched on starting with the chemical energy in the cells. (2 marks)

3.7.2 General Science Paper 2 (237/2)

SECTION A: BIOLOGY (34 marks)

Answer *ALL* the questions in this section in the spaces provided.

- 1 Differentiate between ecology and ecosystem. (2 marks)
- 2 (a) Name **three** air pollutants produced when charcoal is burnt in a poorly ventilated room. (3 marks)
- (b) Name the causative agent of amoebic dysentery. (1 mark)
- 3 The diagram below represents the human male reproductive system.

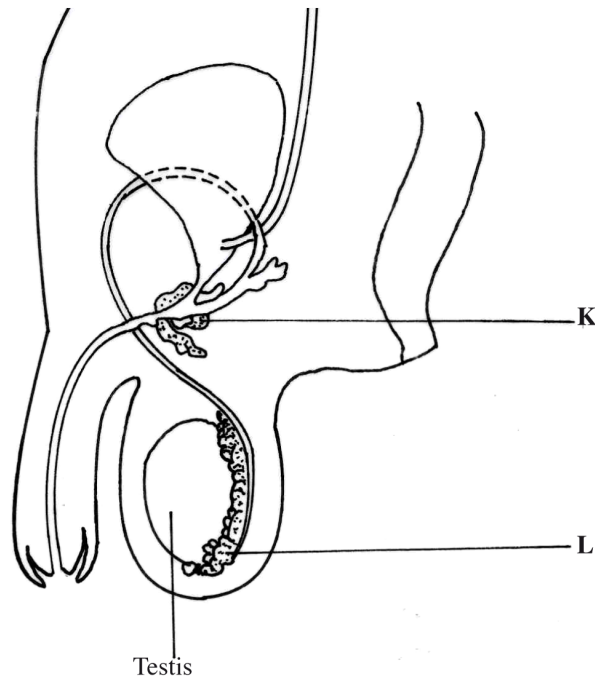

- (a) (i) Name the parts labelled **K** and **L**.
- K**; (1 mark)
- L**. (1 mark)
- (ii) State the role of the hormone produced by the testis. (1 mark)
- (b) What is meant by the term mitosis? (1 mark)
- 4 (a) What is gestation period? (1 mark)
- (b) State **two** symptoms of Herpes simplex. (2 marks)
- (c) What is a genotype? (1 mark)

- 5 (a) State the meaning of seed viability. (1 mark)
- (b) State **two** reasons why water is required for seed germination. (2 marks)
- 6 (a) Giving an example, describe continuous growth in animals. (2 marks)
- (b) Distinguish between the terms homozygosity and heterozygosity. (2 marks)
- 7 (a) What is chemical evolution? (2 marks)
- (b) State **two** ways in which meiosis is important in sexual reproduction. (2 marks)
- 8 State the meaning of the following terms: (3 marks)
- (a) irritability;
- (b) stimulus;
- (c) response.
- 9 Name **three** structures of the human ear that are involved in balance and posture. (3 marks)
- 10 State **three** functions of an endoskeleton. (3 marks)

SECTION B: CHEMISTRY (33 marks)

Answer ALL the questions in this section in the spaces provided.

- 11 The set-up shown below was used to investigate some properties of chlorine gas.

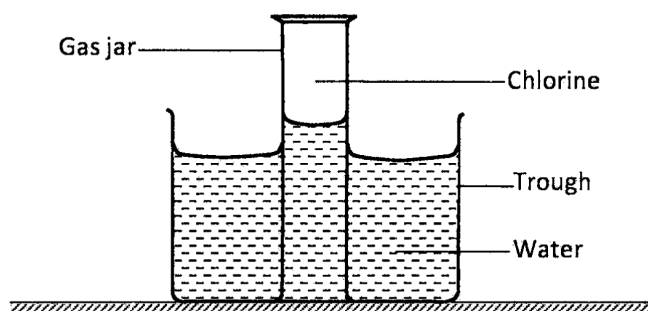

- (a) Explain why the level of water in the gas jar was higher than in the trough after some time. (1 mark)
- (b) (i) What would be observed if blue litmus paper was dipped into the water in the trough? (1 mark)
- (ii) Explain the observations made in b(i) above. (2 marks)

12 Calculate the number of moles contained in 30g of potassium nitrate (K = 39.0; N = 14.0; O = 16.0). (2 marks)

13 A balloon filled with air was tied and held above a trough containing hot water as shown in the diagram.

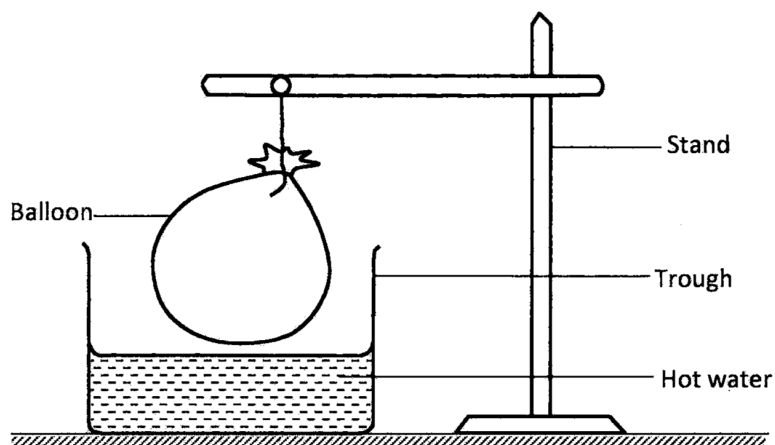

(a) State the observation made on the balloon. (1 mark)

(b) Explain the observation in (a) above. (2 marks)

14 (a) What is meant by the term **dilution**? (1 mark)

(b) Calculate the mass in grams contained in 25.0 cm³ of 0.2M sodium hydroxide solution (Na = 23.0; O = 16.0; H = 1.0). (2 marks)

15 (a) Name **one** natural polymer and state its use. (1 mark)

Natural polymer.

Use.

(b) State **one** advantage and **one** disadvantage of synthetic polymers. (1 mark)

Advantage

Disadvantage

16 (a) Iron metal exists naturally in different ores. Other than haematite, name another common ore of iron. (1 mark)

(b) During the extraction of iron metal, one of the reactions in the blast furnace is:

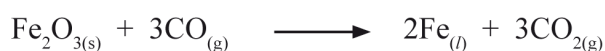

(i) Name the raw material that is used to produce carbon (II) oxide. (1 mark)

(ii) Iron metal produced in the reaction is in liquid state. Explain. (1 mark)

- (c) State with a reason, **one** use of stainless steel. (2 marks)

Use:

Reason:

- 17 The set-up shown below was used by a student to prepare sulphur (IV) oxide gas. Study it and answer the questions that follow.

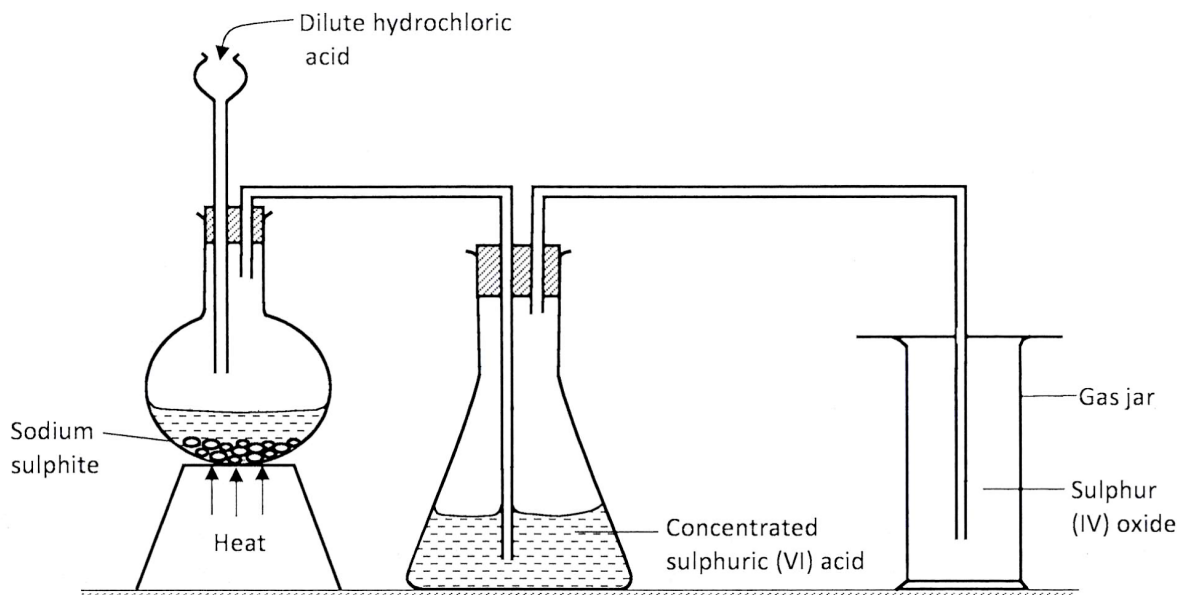

- (a) (i) Identify a mistake on the set-up that will affect collection of sulphur (IV) oxide gas. (½ mark)
- (ii) How would the mistake be corrected? (½ mark)
- (b) (i) State the use of concentrated sulphuric (VI) acid in the above set-up. (1 mark)
- (ii) What would happen if concentrated sulphuric (VI) acid was replaced with water? (1 mark)
- (c) State **one** use of sulphur (IV) oxide gas. (1 mark)

- 18 When Potassium chloride was dissolved in water, the following change occurred.



- (a) (i) State the type of energy change in the above reaction. (1 mark)
- (ii) The above experiment was done in a boiling tube. State the observation that was made. (1 mark)
- (iii) Name the type of reaction in a(ii) above. (1 mark)

(b) Name **two** factors considered when choosing a fuel. (2 marks)

19 (a) Name the compound $\text{CH}_3\text{CHCHCH}_3$. (1 mark)

(b) Name the type of reaction that takes place when the compound in (a) above is reacted with hydrogen chloride gas. (1 mark)

20 0.1M hydrochloric acid was reacted with sodium thiosulphate solution. The time taken for the cross to disappear was recorded at different temperatures as shown on the graph.

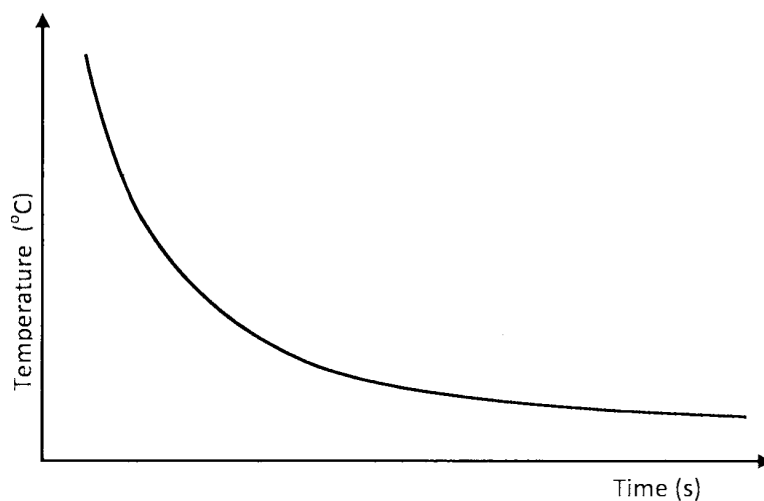

(a) Explain the shape of the curve. (1 mark)

(b) What conclusion would be made from the curve? (1 mark)

(c) Sketch another curve on the same axis that would be obtained when the concentration of hydrochloric acid is doubled. (1 mark)

SECTION C: PHYSICS (33 marks)

Answer **ALL** the questions in this section in the spaces provided.

- 21** **Figure 1**, shows an image I formed when an object O is placed in front of a convex mirror.

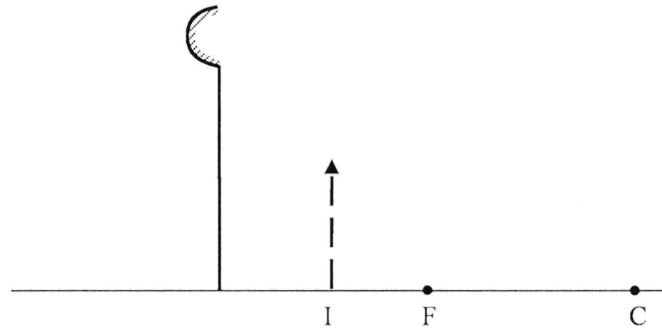

Figure 1

Complete the ray diagram to show the position of object O. (3 marks)

- 22** When a polythene rod is rubbed with a dry piece of cloth, and then brought near a negatively charged pith ball, the ball is observed to move away. Explain this observation. (2 marks)

- 23** (a) Name **one** defect of a simple cell. (1 mark)
- (b) State how the defect in (a) above is minimized. (1 mark)

- 24** **Figure 2** shows iron keepers used in storing bar magnets.

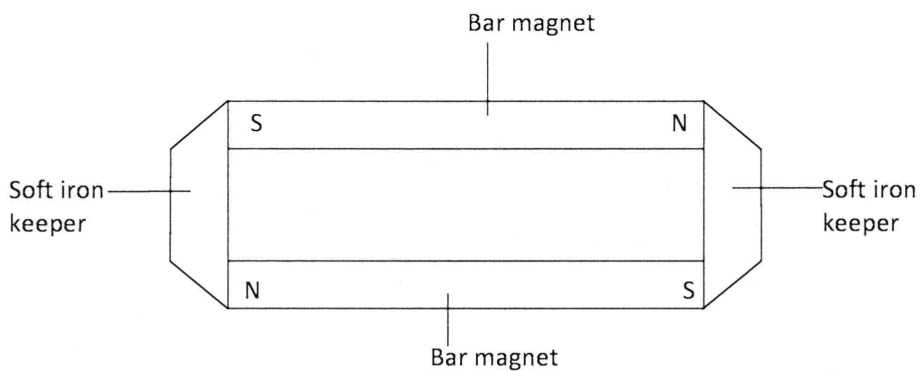

Figure 2

On the figure show the poles induced in the keepers. (1 mark)

- 25 **Figure 3**, shows an arrow which indicates the direction of travel of a wave in a medium. P, a particle of the medium is in the path of the wave.

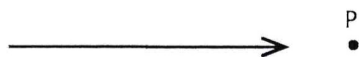

Figure 3

In the space provided, sketch the diagram to show how the particle P moves when the wave is

- (a) transverse. (b) longitudinal (2 marks)
- 26 State **two** factors that affect the speed of sound in air. (2 marks)
- 27 Define the term potential difference. (1 mark)
- 28 **Figure 4**, shows two circuits X and Y in which two identical coils are used to heat two equal amounts of water. The two circuits are switched on at the same time.

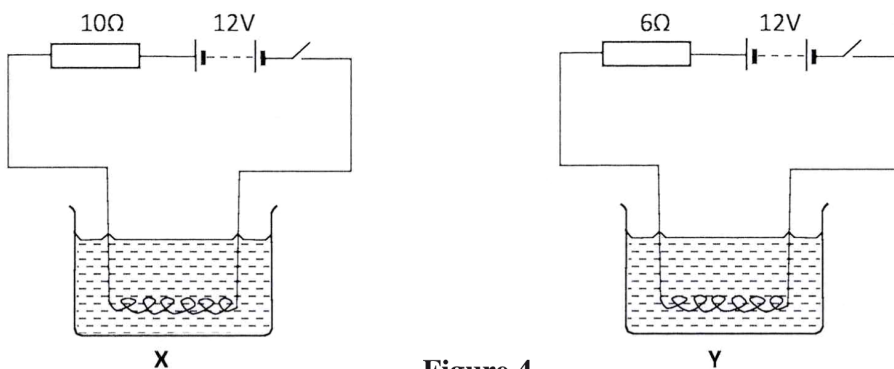

Figure 4

- (a) State the circuit in which the water boils first. (1 mark)
- (b) Explain the answer in (a) above. (2 marks)
- 29 It is observed that a swimming pool full of water appears shallower than it actually is. Explain this observation. (3 marks)

- 30 **Figure 5**, shows an object O placed in front of a converging lens whose principal foci are F_1 and F_2 .

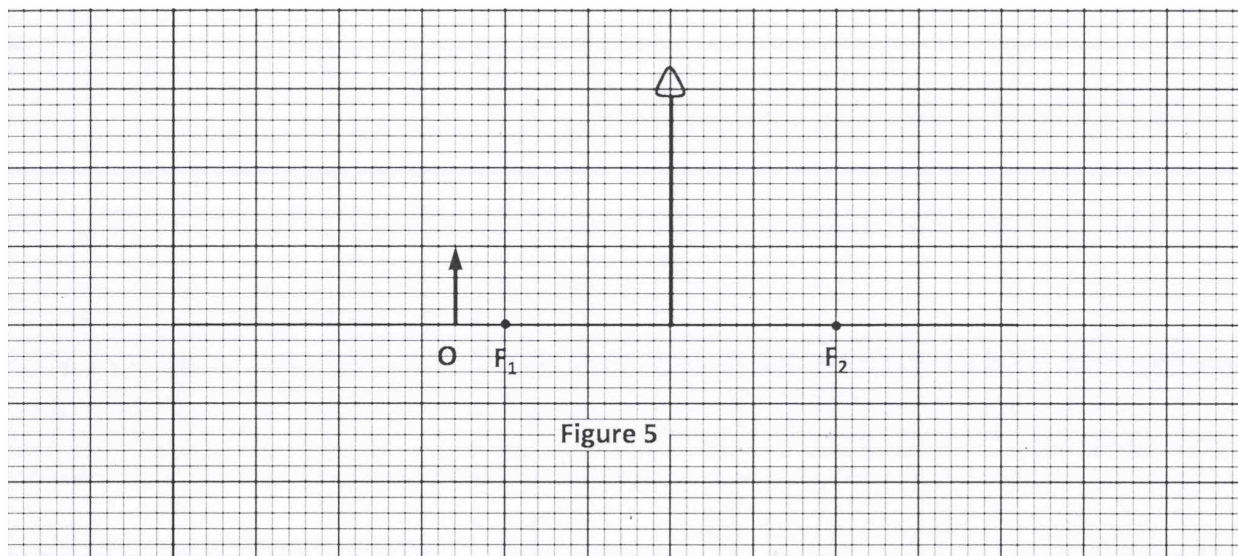

Figure 5

Figure 5

Using rays, complete the diagram to show the position of the image. (3 marks)

- 31 **Figure 6**, shows a displacement - time graph of a wave.

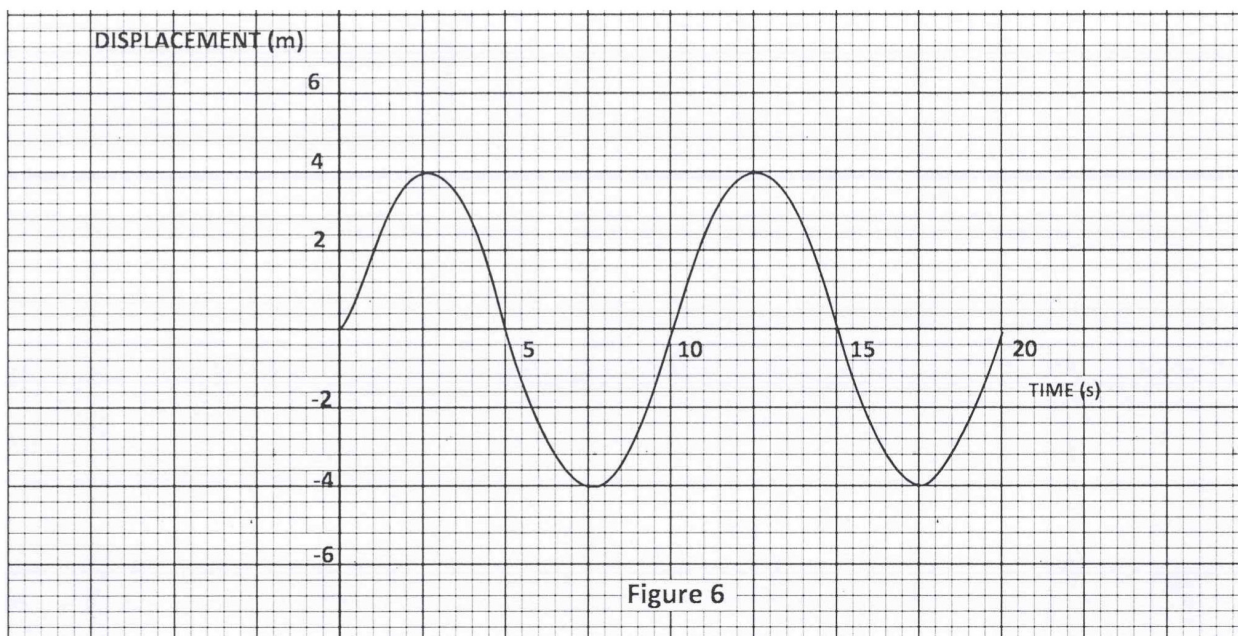

Figure 6

Figure 6

Determine the amplitude of the waveform. (1 mark)

- 32** An electric iron is rated 1500 W. Determine the cost of using the iron for 30 hours given that the cost of electricity is Ksh.8 per kilowatt hour. (3 marks)
- 33** (a) State **one** way in which the path of a cathode ray can be changed. (1 mark)
- (b) The control grid in a cathode ray oscilloscope (CRO) is used to control the brightness of the spot on the screen. Explain how the brightness of the spot may be reduced. (2 marks)
- 34** State **two** ways in which the conductivity of a semiconductor can be increased. (2 marks)
- 35** Explain the danger of radioactive emissions on a human body. (2 marks)