

3.3 MATHEMATICS (121 AND 122)

3.3.1 Mathematics Alt.A Paper 1 (121/1)

SECTION I (50 marks)

Answer *all* the questions in this section in the spaces provided.

- 1 Ntutu had cows, sheep and goats in his farm. The number of cows was 32 and number of sheep was twelve times the number of cows. The number of goats was 1344 more than the number of sheep. If he sold $\frac{3}{4}$ of the goats, find the number of goats that remained. (4 marks)

- 2 Use the prime factors of 1764 and 2744 to evaluate

$$\frac{\sqrt{1764}}{\sqrt[3]{2744}}$$

(3 marks)

- 3 The mass of a solid cone of radius 14 cm and height 18 cm is 4.62 kg. Find its density in g/cm^3 . (3 marks)

- 4 The figure below represents a triangular prism ABCDEF. X is a point on BC.

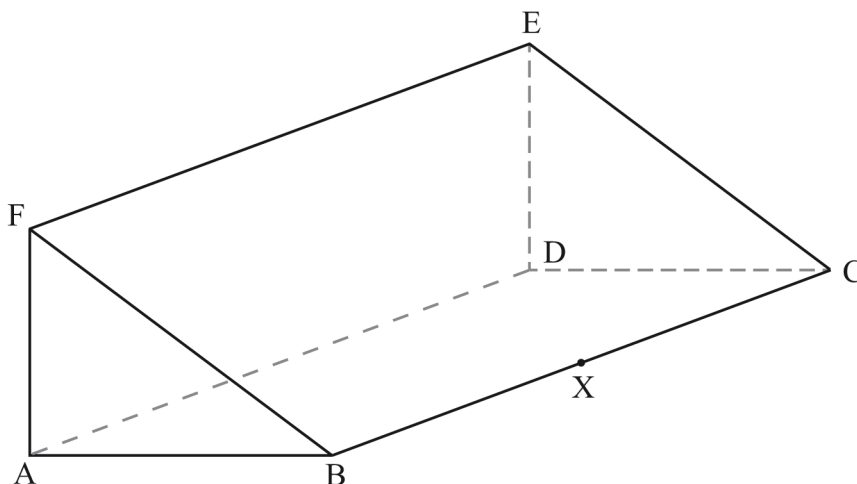

- (a) Draw a net of the prism. (2 marks)
- (b) Find the distance DX. (1 mark)
- 5 A businessman makes a profit of 20% when he sells a carpet for Ksh 36 000. In a trade fair he sold one such carpet for Ksh 33 600. Calculate the percentage profit made on the sale of the carpet during the trade fair. (3 marks)

6 Simplify $\frac{243^{\frac{-2}{5}} \times 125^{\frac{2}{3}}}{9^{\frac{-3}{2}}}$ (3 marks)

7 The area of a sector of a circle, radius 2.1 cm, is 2.31 cm^2 . The arc of the sector subtends an angle θ , at the centre of the circle. Find the value of θ in radians correct to 2 decimal places. (2 marks)

8 Expand and simplify $(x + 2y)^2 - (2y - 3)^2$. (2 marks)

9 A plane leaves an airstrip L and flies on a bearing of 040° to airstrip M, 500 km away. The plane then flies on a bearing of 316° to airstrip N. The bearing of N from L is 350° . By scale drawing, determine the distance between airstrips M and N. (4 marks)

10 The sum of interior angles of a regular polygon is 1800° . Find the size of each exterior angle. (3 marks)

11 A cow is 4 years 8 months older than a heifer. The product of their ages is 8 years. Determine the age of the cow and that of the heifer. (4 marks)

12 Solve $4 \leq 3x - 2 < 9 + x$ hence list the integral values that satisfies the inequality. (3 marks)

13 The figure below shows a rectangular container of dimensions 40 cm by 25 cm by 90 cm. A cylindrical pipe of radius 7.5 cm is fitted in the container as shown.

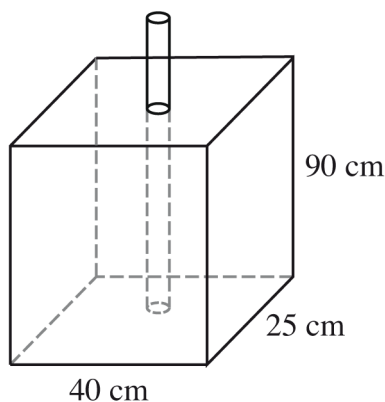

Water is poured into the container in the space outside the pipe such that the water level is 80% the height of the container. Calculate the amount of water, in litres, in the container correct to 3 significant figures. (4 marks)

14 A minor arc of a circle subtends an angle of 105° at the centre of the circle. If the radius of the circle is 8.4 cm, find the length of the major arc. (Take $\pi = \frac{22}{7}$) (3 marks)

- 15 Twenty five machines working at a rate of 9 hours per day can complete a job in 16 days. A contractor intends to complete the job in 10 days using similar machines working at a rate of 12 hours per day. Find the number of machines the contractor requires to complete the job. (3 marks)
- 16 Points A $(-2, 2)$ and B $(-3, 7)$ are mapped onto A' $(4, -10)$ and B' $(0, 10)$ by an enlargement. Find the scale factor of the enlargement. (3 marks)

SECTION II (50 marks)

Answer only five questions in this section in the spaces provided.

- 17 A line L passes through points $(-2, 3)$ and $(-1, 6)$ and is perpendicular to a line P at $(-1, 6)$.
- (a) Find the equation of L. (2 marks)
- (b) Find the equation of P in the form $ax + by = c$, where a, b and c are constants. (2 marks)
- (c) Given that another line Q is parallel to L and passes through point $(1, 2)$, find the x and y intercepts of Q. (3 marks)
- (d) Find the point of intersection of lines P and Q. (3 marks)
- 18 The lengths, in cm, of pencils used by pupils in a standard one class on a certain day were recorded as follows.
- | | | | | | | | | | |
|----|----|----|----|----|----|----|----|----|----|
| 3 | 7 | 9 | 9 | 20 | 14 | 10 | 6 | 8 | 13 |
| 14 | 3 | 17 | 13 | 8 | 12 | 5 | 15 | 14 | 15 |
| 7 | 12 | 11 | 6 | 10 | 19 | 9 | 14 | 6 | 9 |
| 10 | 16 | 13 | 9 | 12 | 11 | 10 | 7 | 10 | 11 |
- (a) Using a class width of 3, and starting with the shortest length of the pencils, make a frequency distribution table for the data. (2 marks)
- (b) Calculate:
- (i) the mean length of the pencils; (3 marks)
- (ii) the percentage of pencils that were longer than 8 cm but shorter than 15 cm. (2 marks)
- (c) On the grid provided, draw a frequency polygon for the data. (3 marks)

- 19 The figure below represents a speed time graph for a cheetah which covered 825 m in 40 seconds.

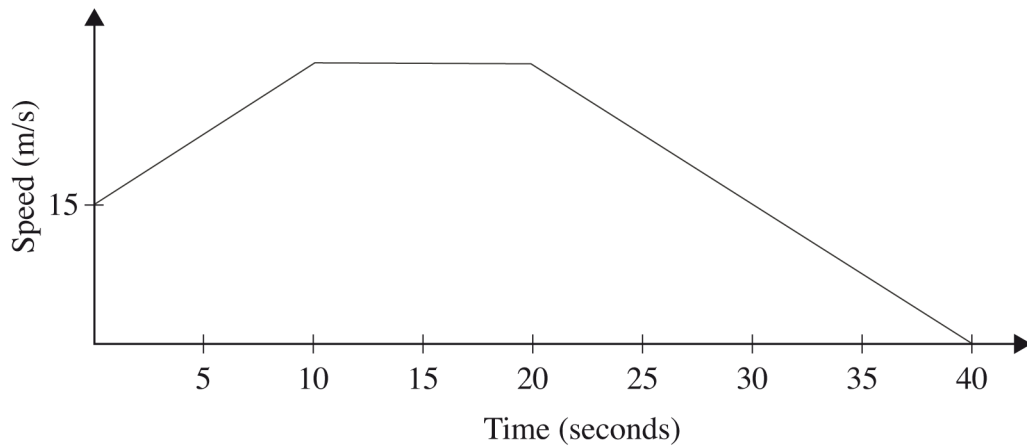

- (a) State the speed of the cheetah when recording of its motion started. (1 mark)
- (b) Calculate the maximum speed attained by the cheetah. (3 marks)
- (c) Calculate the acceleration of the cheetah in:
- (i) the first 10 seconds; (2 marks)
- (ii) the last 20 seconds. (1 mark)
- (d) Calculate the average speed of the cheetah in the first 20 seconds. (3 marks)

- 20 The figure below shows a right pyramid VABCDE. The base ABCDE is a regular pentagon. $AO = 15$ cm and $VO = 36$ cm.

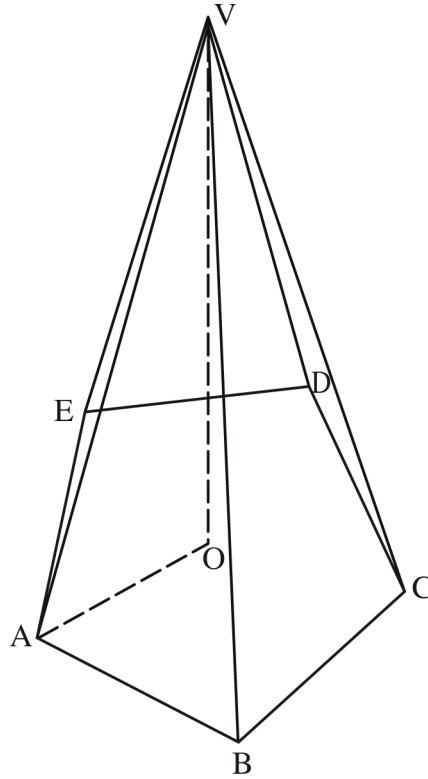

Calculate:

- (a) the area of the base correct to 2 decimal places; (3 marks)
- (b) the length AV; (1 mark)
- (c) the surface area of the pyramid correct to 2 decimal places; (4 marks)
- (d) the volume of the pyramid correct to 4 significant figures. (2 marks)
- 21 (a) Complete the table below for the function $y = x^2 - 3x + 6$ in the range $-2 \leq x \leq 8$. (2 marks)

x	-2	-1	0	1	2	3	4	5	6	7	8
y											

- (b) Use the trapezium rule with 10 strips to estimate the area bounded by the curve, $y = x^2 - 3x + 6$, the lines $x = -2$, $x = 8$, and the x-axis. (3 marks)
- (c) Use the mid-ordinate rule with 5 strips to estimate the area bounded by the curve, $y = x^2 - 3x + 6$, the lines $x = -2$, $x = 8$ and the x-axis. (2 marks)
- (d) By integration, determine the actual area bounded by the curve $y = x^2 - 3x + 6$, the lines $x = -2$, $x = 8$, and the x-axis. (3 marks)

- 22 (a) Using a pair of compasses and ruler only, construct:
- triangle ABC in which $AB = 5 \text{ cm}$, $\angle BAC = 30^\circ$ and $\angle ABC = 105^\circ$; (3 marks)
 - a circle that passes through the vertices of the triangle ABC. Measure the radius. (3 marks)
 - the height of triangle ABC with AB as the base. Measure the height. (2 marks)
- (b) Determine the area of the circle that lies outside the triangle correct to 2 decimal places. (2 marks)

- 23 The figure below represents a piece of land in the shape of a quadrilateral in which $AB = 240 \text{ m}$, $BC = 70 \text{ m}$, $CD = 200 \text{ m}$, $\angle BCD = 150^\circ$ and $\angle ABC = 90^\circ$.

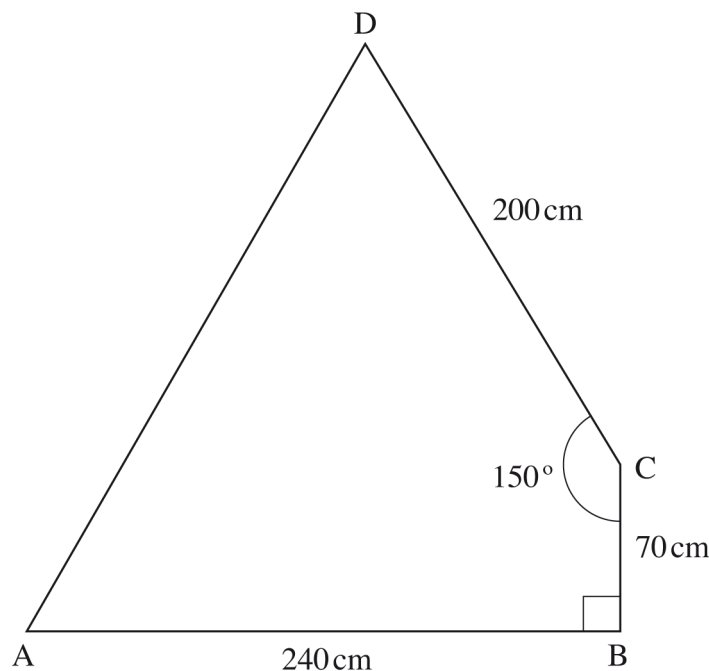

Calculate:

- the size of $\angle BAC$ correct to 2 decimal places; (2 marks)
 - the length AD correct to one decimal place; (4 marks)
 - the area of the piece of land, in hectares, correct to 2 decimal places. (4 marks)
- 24 The equation of a curve is given by $y = x^3 - 4x^2 - 3x$.
- Find the value of y when $x = -1$. (1 mark)
 - Determine the stationary points of the curve. (5 marks)
 - Find the equation of the normal to the curve at $x = 1$. (4 marks)

SECTION I (50 marks)

Answer **all** the questions in this section in the spaces provided.

- 1 The lengths of two similar iron bars were given as 12.5 m and 9.23 m. Calculate the maximum possible difference in length between the two bars. (3 marks)
- 2 The first term of an arithmetic sequence is -7 and the common difference is 3.
 - (a) List the first six terms of the sequence; (1 mark)
 - (b) Determine the sum of the first 50 terms of the sequence. (2 marks)
- 3 In the figure below, BOD is the diameter of the circle centre O. Angle $ABD = 30^\circ$ and angle $AXD = 70^\circ$.

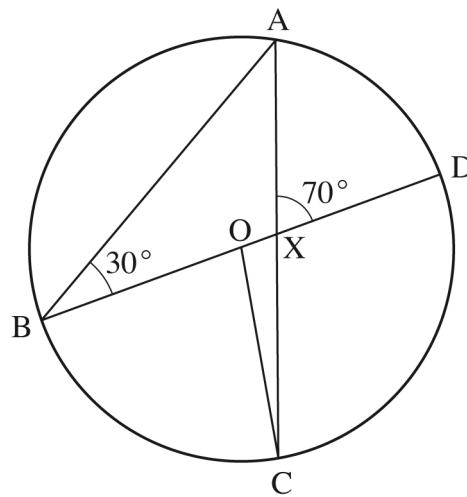

Determine the size of:

- (a) reflex angle BOC; (2 marks)
 - (b) angle ACO. (1 mark)
- 4 Three quantities L, M and N are such that L varies directly as M and inversely as the square of N. Given that $L = 2$ when $M = 12$ and $N = 6$, determine the equation connecting the three quantities. (3 marks)

- 5 The table below shows the frequency distribution of marks scored by students in a test.

Marks	Frequency
1 – 10	2
11 – 20	4
21 – 30	11
31 – 40	5
41 – 50	3

Determine the median mark correct to 2 s.f. (4 marks)

- 6 Determine the amplitude and period of the function, $y = 2 \cos (3x - 45)^\circ$. (2 marks)

- 7 In a transformation, an object with an area of 5 cm^2 is mapped onto an image whose area is 30 cm^2 . Given that the matrix of the transformation is $\begin{pmatrix} x & x-1 \\ 2 & 4 \end{pmatrix}$, find the value of x . (3 marks)

- 8 Expand $(3 - x)^7$ up to the term containing x^4 . Hence find the approximate value of $(2.8)^7$. (3 marks)

- 9 Solve the equation;

$$2 \log 15 - \log x = \log 5 + \log (x - 4). \quad (4 \text{ marks})$$

- 10 The figure below represents a cuboid PQRSTU VW.

PQ = 60 cm, QR = 11 cm and RW = 10 cm.

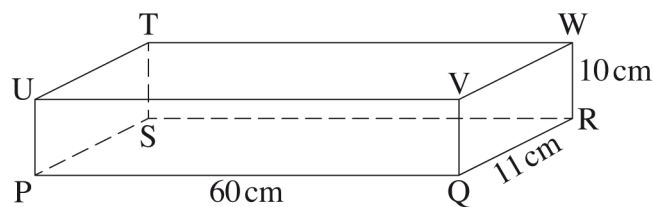

Calculate the angle between line PW and plane PQRS, correct to 2 decimal places. (3 marks)

- 11 Solve the simultaneous equations;

$$3x - y = 9$$

$$x^2 - xy = 4 \quad (4 \text{ marks})$$

- 12 Muga bought a plot of land for Ksh 280 000. After 4 years, the value of the plot was Ksh 495 000. Determine the rate of appreciation, per annum, correct to one decimal place. (3 marks)
- 13 The shortest distance between two points A (40°N , 20°W) and B ($\theta^\circ\text{S}$, 20°W) on the surface of the earth is 8008 km. Given that the radius of the earth is 6370 km, determine the position of B. (Take $\pi = \frac{22}{7}$). (3 marks)
- 14 Vectors \mathbf{r} and \mathbf{s} are such that $\mathbf{r} = 7\mathbf{i} + 2\mathbf{j} - \mathbf{k}$ and $\mathbf{s} = -\mathbf{i} + \mathbf{j} - \mathbf{k}$. Find $|\mathbf{r} + \mathbf{s}|$. (3 marks)
- 15 The gradient of a curve is given by $\frac{dy}{dx} = x^2 - 4x + 3$. The curve passes through the point (1,0). Find the equation of the curve. (3 marks)
- 16 The graph below shows the rate of cooling of a liquid with respect to time.

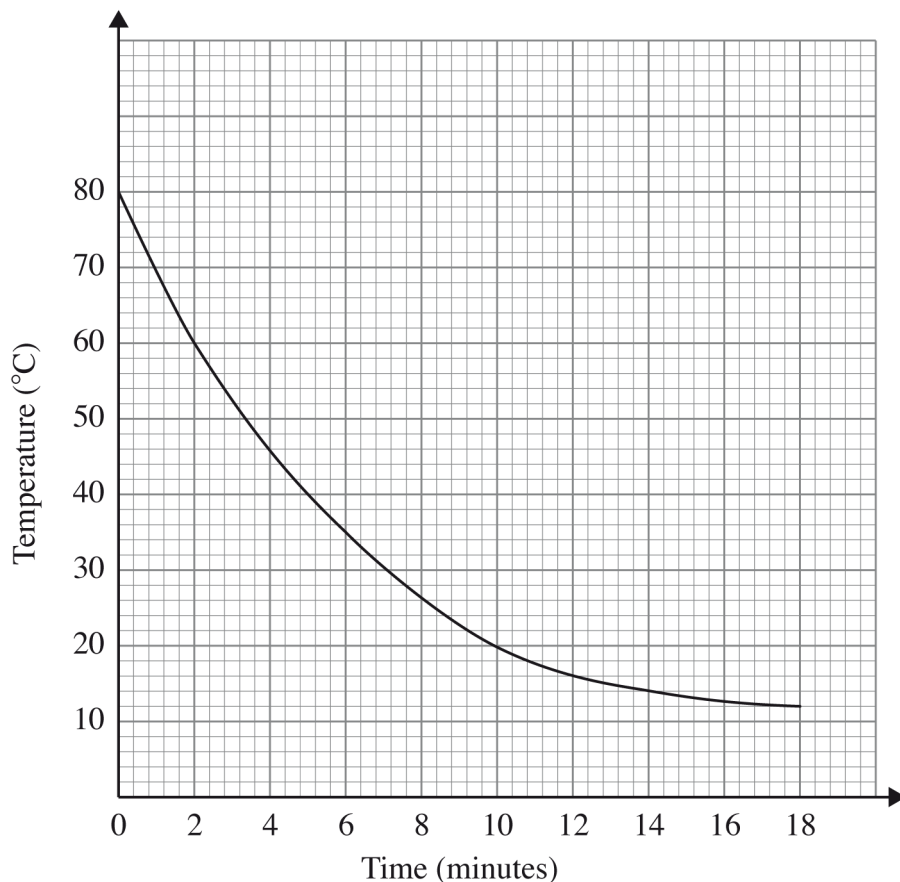

Determine the average rate of cooling of the liquid between the second and the eleventh minutes. (3 marks)

SECTION II (50 marks)

*Answer only **five** questions in this section in the spaces provided.*

17 A paint dealer mixes three types of paint A, B and C, in the ratios $A:B = 3:4$ and $B:C = 1:2$. The mixture is to contain 168 litres of C.

- (a) Find the ratio $A:B:C$. (2 marks)
- (b) Find the required number of litres of B. (2 marks)
- (c) The cost per litre of type A is Ksh 160, type B is Ksh 205 and type C is Ksh 100.
 - (i) Calculate the cost per litre of the mixture. (2 marks)
 - (ii) Find the percentage profit if the selling price of the mixture is Ksh 182 per litre. (2 marks)
 - (iii) Find the selling price of a litre of the mixture if the dealer makes a 25% profit. (2 marks)

18 In the figure below OS is the radius of the circle centre O. Chords SQ and TU are extended to meet at P and OR is perpendicular to QS at R. $OS = 61$ cm, $PU = 50$ cm, $UT = 40$ cm and $PQ = 30$ cm.

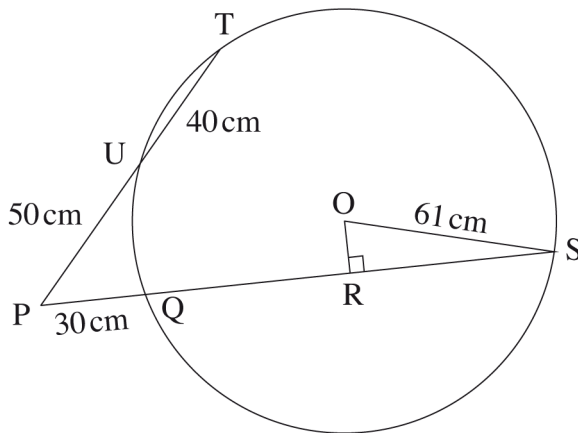

- (a) Calculate the length of:
 - (i) QS; (2 marks)
 - (ii) OR. (3 marks)
- (b) Calculate, correct to 1 decimal place:
 - (i) the size of angle ROS; (2 marks)
 - (ii) the length of the minor arc QS. (3 marks)

- 19 The table below shows income tax rates for a certain year.

Monthly income in Kenya shillings (Ksh)	Tax rate in each shilling
0 – 10164	10%
10165 – 19740	15%
19741 – 29316	20%
29317 – 38892	25%
over 38892	30%

A tax relief of Ksh 1162 per month was allowed. In a certain month, of that year, an employee's taxable income in the fifth band was Ksh 2108.

- (a) Calculate:
- (i) the employee's total taxable income in that month; (2 marks)
 - (ii) the tax payable by the employee in that month. (5 marks)
- (b) The employee's income included a house allowance of Ksh 15 000 per month. The employee contributed 5% of the basic salary to a co-operative society. Calculate the employees net pay for that month. (3 marks)

- 20 The dimensions of a rectangular floor of a proposed building are such that:
- the length is greater than the width but at most twice the width;
 - the sum of the width and the length is, more than 8 metres but less than 20 metres. If x represents the width and y the length.

- (a) write inequalities to represent the above information. (4 marks)
- (b) (i) Represent the inequalities in part (a) above on the grid provided. (4 marks)
- (ii) Using the integral values of x and y , find the maximum possible area of the floor. (2 marks)

21 Each morning Gataro does one of the following exercises:
 Cycling, jogging or weightlifting.
 He chooses the exercise to do by rolling a fair die. The faces of the die are numbered
 1, 1, 2, 3, 4 and 5.
 If the score is 2, 3 or 5, he goes for cycling.
 If the score is 1, he goes for jogging.
 If the score is 4, he goes for weightlifting.

- (a) Find the probability that:
- (i) on a given morning, he goes for cycling or weightlifting; (2 marks)
 - (ii) on two consecutive mornings he goes for jogging. (2 marks)
- (b) In the afternoon, Gataro plays either football or hockey but never both games. The probability that Gataro plays hockey in the afternoon is:
- $\frac{1}{3}$ if he cycled;
 - $\frac{2}{5}$ if he jogged and
 - $\frac{1}{2}$ if he did weightlifting in the morning.

Complete the tree diagram below by writing the appropriate probability on each branch. (2 marks)

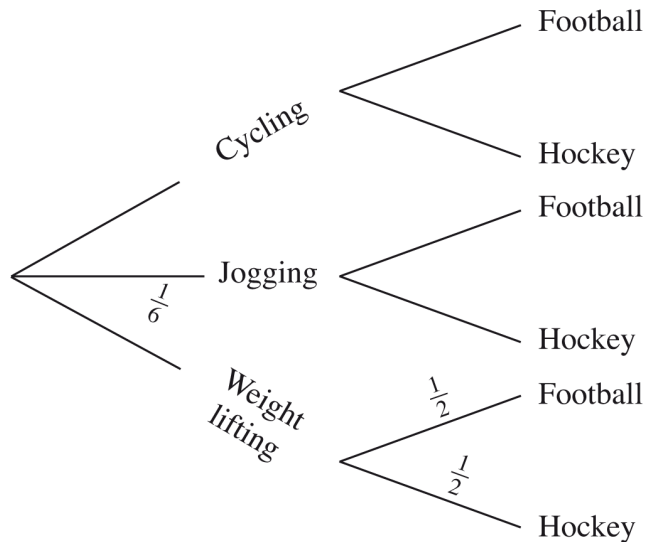

- (c) Find the probability that on any given day:
- (i) Gataro plays football; (2 marks)
 - (ii) Gataro neither jogs nor plays football. (2 marks)

- 22 In the figure below $\mathbf{OA} = \mathbf{a}$ and $\mathbf{OB} = \mathbf{b}$. M is the mid-point of OA and $AN:NB = 2:1$.

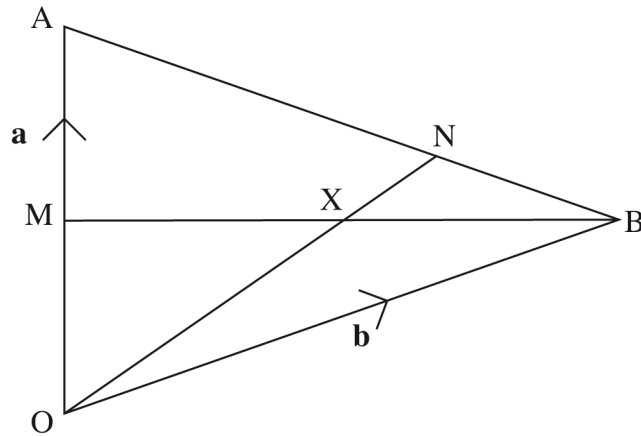

- (a) Express in terms of \mathbf{a} and \mathbf{b} :
- (i) \mathbf{BA} ; (1 mark)
 - (ii) \mathbf{BN} ; (1 mark)
 - (iii) \mathbf{ON} . (2 marks)
- (b) Given that $\mathbf{BX} = h\mathbf{BM}$ and $\mathbf{OX} = k\mathbf{ON}$ determine the values of h and k . (6 marks)
- 23 Figure ABCD below is a scale drawing representing a square plot of side 80 metres.

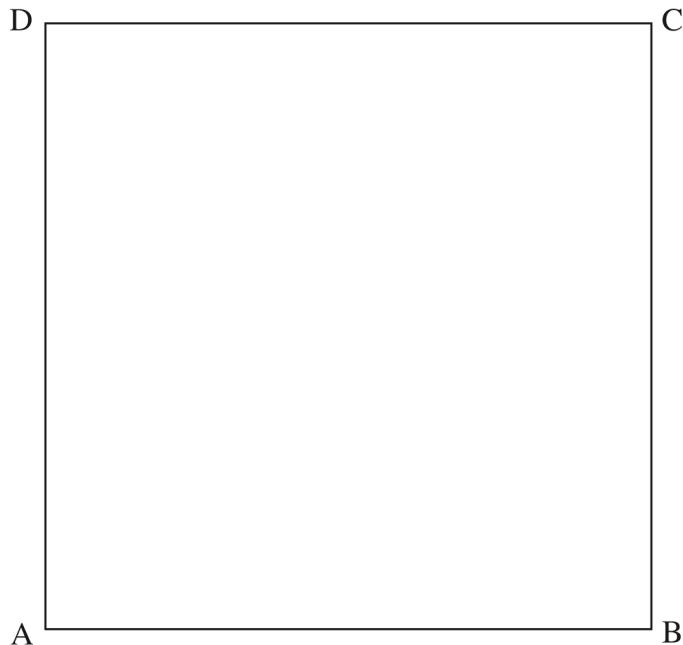

- (a) On the drawing, construct:
- (i) the locus of a point P, such that it is equidistant from AD and BC. (2 marks)
 - (ii) the locus of a point Q such that $\angle AQB = 60^\circ$. (3 marks)

- (b) (i) Mark on the drawing the point Q_1 , the intersection of the locus of Q and line AD. Determine the length of BQ_1 , in metres. (1 mark)
- (ii) Calculate, correct to the nearest m^2 , the area of the region bounded by the locus of P, the locus of Q and the line BQ_1 . (4 marks)

24 In an experiment involving two variables t and r , the following results were obtained.

t	1.0	1.5	2.0	2.5	3.0	3.5
r	1.50	1.45	1.30	1.25	1.05	1.00

- (a) On the grid provided, draw the line of best fit for the data. (4 marks)
- (b) The variables r and t are connected by the equation $r = at + k$ where a and k are constants. Determine:
- (i) the values of a and k ; (3 marks)
- (ii) the equation of the line of best fit. (1 mark)
- (iii) the value of t when $r = 0$. (2 marks)

3.3.3 Mathematics Alt. B Paper 1 (122/1)

SECTION I (50 marks)

Answer *all* the questions in this section in the spaces provided.

1 Evaluate

$$\frac{-8 \times +2 + -11}{+18 \div -2 \times +3}$$

(2 marks)

2 During a prize-giving day in a school, there were four times as many students as parents. The number of girls was 84 more than the number of boys. If there were 630 girls, calculate the number of parents present. (3 marks)

3 Given that $3x + 5y = 300$ and $x + y = 78$, find the value of $10x + 15y$. (3 marks)

4 A group of families shared 96 packets of maize meal, 84 packets of wheat flour and 36 packets of sugar.

Determine:

(a) the greatest number of families that shared the foodstuffs equally; (2 marks)

(b) the total number of packets of foodstuffs that each family received. (2 marks)

5 Express $\frac{128}{2^5 \div 2^8}$ in the simplest index form. (3 marks)

6 Line AB shown below is a side of a parallelogram ABCD in which $AD = 6$ cm and angle $DAB = 30^\circ$.



Using a pair of compasses and ruler only, complete the parallelogram ABCD. (3 marks)

7 An acute angle α is such that $\sin(4\alpha)^\circ = \cos(\alpha + 10)^\circ$. Find:

(a) the value of α ; (2 marks)

(b) $\sin \alpha$, correct to 3 decimal places. (1 mark)

8 Without using a calculator or mathematical tables, evaluate:

$$\frac{0.375 \div 0.06 - 4.2}{3.96 + 2.8 \times 0.05}$$

(3 marks)

- 9 Three children Awino, Buko and Chebet had two types of fruits each. Awino had twice as many mangoes as Buko while Buko had three times as many mangoes as Chebet. Also, Buko had three times as many oranges as Awino while Chebet had twice as many oranges as Awino. If Buko had x mangoes and y oranges, write a simplified expression to represent the total number of fruits the three children had. (3 marks)
- 10 A solid has a circular cross-section of radius 1.4 cm and a height of 4 cm.
- (a) Name the solid. (1 mark)
- (b) Draw an accurate net of the solid. (2 marks)
- 11 The tip of the minute hand of a clock moves through a distance of 17.6 cm between 3.00 pm and 3.12 pm. Find the length of the minute hand. (4 marks)
- 12 In the figure below, O is the centre of the circle. PQRS is a cyclic quadrilateral and RST is a straight line. Angle RPQ = 21° and angle TSP = 147° .

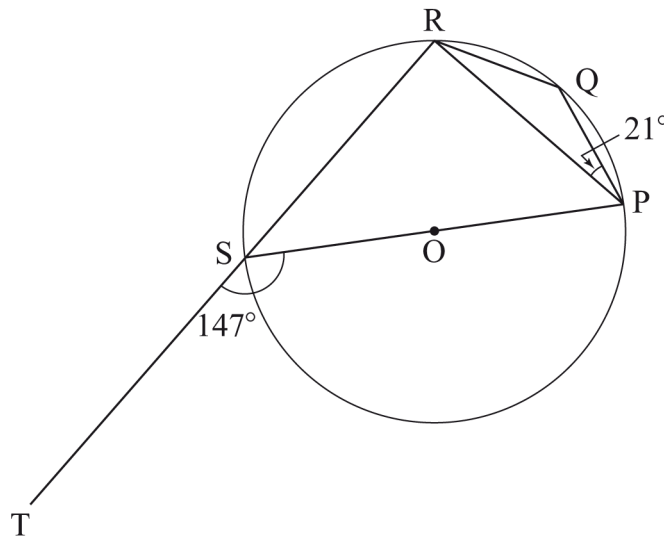

- Calculate the size of angle SRQ. (3 marks)
- 13 Factorise $2x^2 + 6y - 3x - 4xy$. (2 marks)
- 14 The area of a rhombus is 34 cm^2 . One of the interior angles is 30° . Calculate the length of a side of the rhombus to the nearest centimetre. (3 marks)

- 15 The vertices of a triangle are $P(-3,1)$, $Q(1,3)$ and $R(4,2)$. The vertices of its image under an enlargement are $P'(-7,4)$, $Q'(1,8)$ and $R'(7,6)$.

(a) On the grid provided, draw triangle PQR and its image. (2 marks)

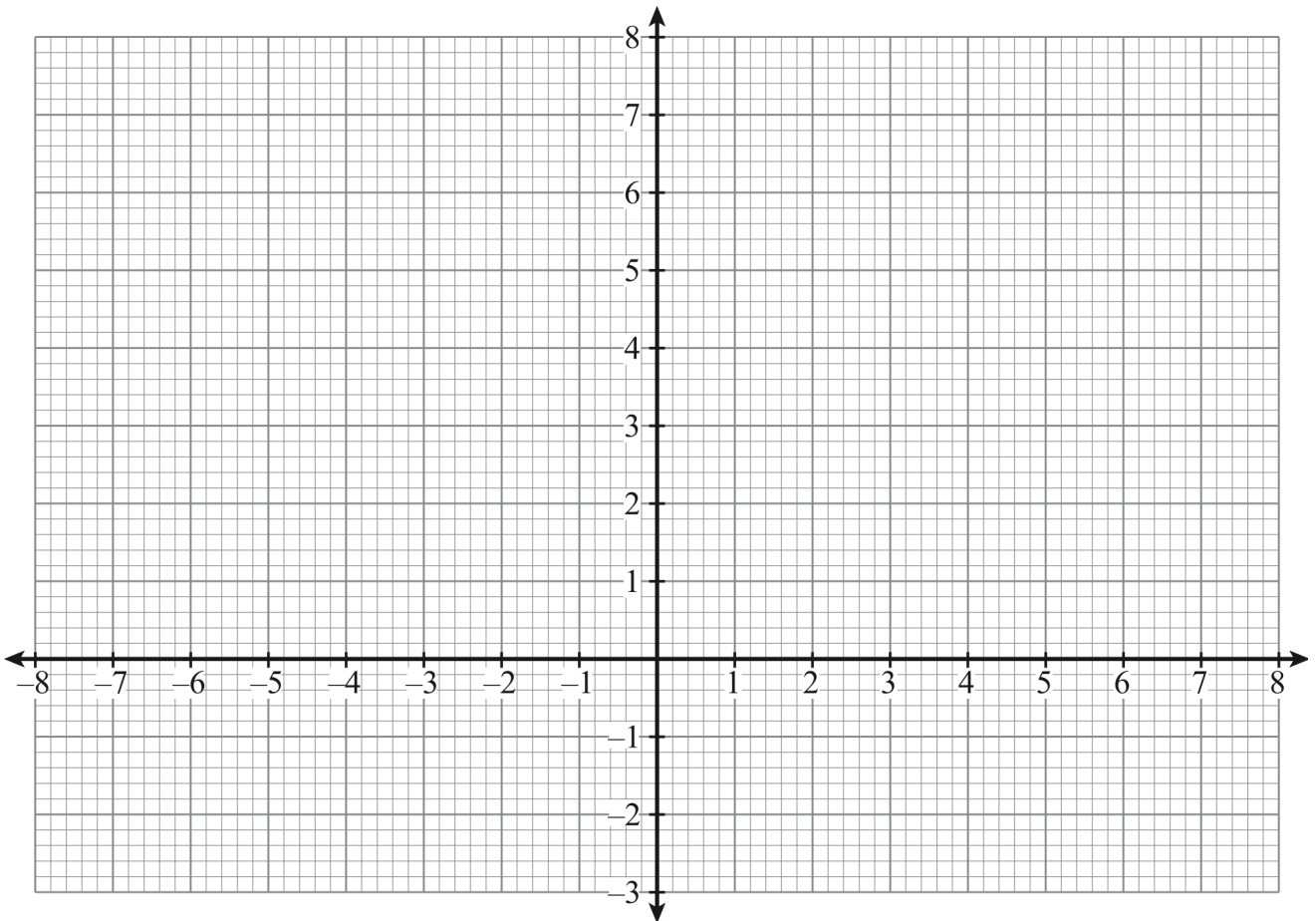

(b) Determine the centre and scale factor of the enlargement. (2 marks)

- 16 A tumbler is in the shape of a frustum of a cone. The radii of the circular ends are 2.1 cm and 3.5 cm. The slant height of the tumbler is 5 cm. Calculate the area of the curved surface. (4 marks)

SECTION II (50 marks)

*Answer any **five** questions from this section in the spaces provided.*

17 Keya, Limo and Mumo invested some money into a business. Keya contributed Ksh 30 000, Limo contributed Ksh 50 000 and Mumo contributed 25% of the total amount contributed by Keya and Limo.

(a) Calculate:

(i) the amount of money contributed by Mumo; (2 marks)

(ii) the ratio in which Keya, Limo and Mumo made their contribution. (2 marks)

(b) After one year, the business realised a profit of Ksh 25 000 which was shared by the partners in the ratio of their contributions. Find the amount of money Mumo got. (2 marks)

(c) During the second year, Mumo added some more money to the business. The new ratio of their contributions was, Keya:Limo:Mumo = 3:5:7.

Calculate:

(i) the total amount of money Mumo added to the business in the second year. (2 marks)

(ii) Mumo's percentage contribution in the business by the end of the second year. (2 marks)

18 The capacity of a cylindrical container is 1.54 litres. The height of the container is 10 cm.

(Take $\pi = \frac{22}{7}$)

(a) Calculate the diameter of the container. (3 marks)

(b) Along each end of the curved surface, a ribbon of width 1.5 cm is fixed with an overlap of 2 cm.

Calculate:

(i) the total length of the ribbon used; (3 marks)

(ii) the surface area of the part of container covered by the ribbon. (1 mark)

(c) Given that the container is open at one end, calculate the outer surface area of the container. (3 marks)

- 19 Figure ABCD below is a scale drawing of a piece of land in which AD represents 90 m. The square PQRS represents the homestead.

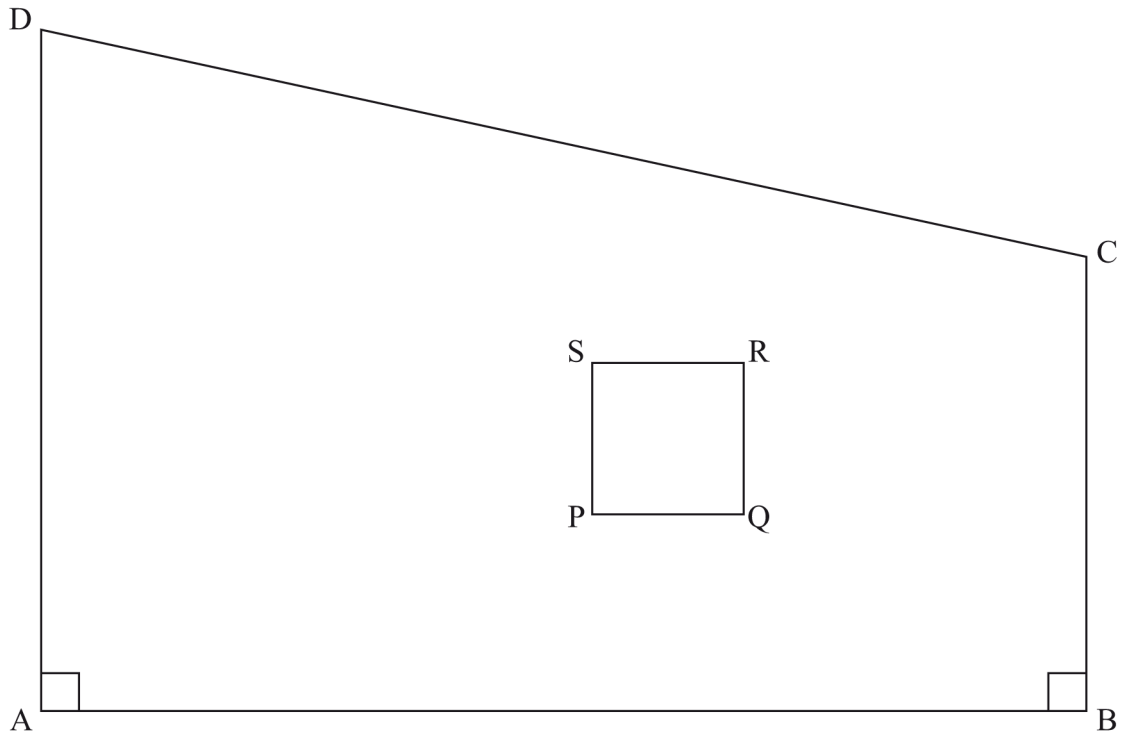

- (a) State, in ratio form, the scale used. (2 marks)
- (b) Calculate:
- (i) the perimeter of the homestead in metres. (2 marks)
- (ii) the area of the piece of land in hectares. (3 marks)
- (c) On the scale drawing show the shortest distance from the centre of the homestead to side CD and hence determine the distance in metres. (3 marks)
- 20 A line L_1 passes through points $(-3, -2)$ and $(6, 1)$.
- (a) Find the equation of L_1 in the form $y = mx + c$, where m and c are constants. (3 marks)
- (b) A line L_2 is perpendicular to L_1 and passes through point $(-1, 2)$. Find the equation of L_2 in the form $ax + by + c = 0$, where a , b and c are constants. (3 marks)
- (c) Another line L_3 is parallel to L_2 and passes through point $(1, 1)$. Determine the co-ordinates of the x -intercept and the y -intercept of L_3 . (4 marks)

- 21** Using a ruler and a pair of compasses only:
- (a) Construct triangle PQR such that $PQ = 6.5$ cm, $QR = 8$ cm, and angle $PQR = 75^\circ$. (4 marks)
- (b) On triangle PQR in part (a) above, construct:
- (i) the perpendicular bisector of line RP to meet line RP at M and line RQ at N. (1 mark)
- (ii) the bisector of angle RPQ to meet line MN at O. Measure angle POM. (2 marks)
- (iii) a circle centre O and radius OM, to meet line RQ at X and Y. Measure chord XY and angle XOY. (3 marks)
- 22** An athlete ran two laps around a 400 metre track. He ran the first lap in 64 seconds and then increased his speed in the second lap by 6%.
- (a) Calculate his speed, in metres per second, during:
- (i) the first lap; (2 marks)
- (ii) the second lap; (2 marks)
- (b) Calculate, to 2 decimal places:
- (i) the total time taken to run the two laps; (3 marks)
- (ii) the average speed, in km/h, for the two laps. (3 marks)
- 23** Kerubo bought 420 bananas at Ksh 20 for every 8 bananas. For every 70 bananas she bought, she was given one extra banana. She hired a cart for Ksh 50 to transport the bananas. During transportation 14 bananas got spoilt and the remaining ones were sold.
- (a) Determine:
- (i) the total amount of money that Kerubo spent; (2 marks)
- (ii) the number of bananas sold. (1 mark)
- (b) Kerubo made a 60% profit after selling some of the bananas at Ksh 30 for every 5 and the rest at Ksh 10 for every 3.
- Calculate:
- (i) the number of bananas sold at Ksh 30 for every 5. (4 marks)
- (ii) the amount of money obtained from the bananas sold at Ksh 10 for every 3. (3 marks)

- 24 (a) (i) On the grid provided, draw triangle RST such that $R(-3,1)$, $S(-3,-4)$ and $T(2,-4)$. (1 mark)
- (ii) Determine the area of the triangle RST. (2 marks)
- (b) On the same grid:
- (i) plot point U such that RSTU is a square. State the coordinates of point U; (2 marks)
- (ii) plot point V such that $SV = 2SU$ and S, U and V lie on a straight line. State the coordinates of V. (2 marks)
- (c) Calculate the area of RSTV. (3 marks)

3.3.4 Mathematics Alt. B Paper 2 (122/2)

SECTION I (50 marks)

Answer **all** the questions in this section in the spaces provided.

- 1 Use a calculator to evaluate $\frac{(0.214)^{\frac{1}{2}} - (0.38)^3}{(0.817)^{\frac{1}{4}}}$ giving the answer correct to 4 significant figures. (2 marks)
- 2 The third term of a geometric progression is $1\frac{1}{4}$ and the sixth term is $\frac{5}{32}$. Determine:
- (a) the common ratio; (2 marks)
- (b) the first term. (2 marks)
- 3 The lengths of the parallel sides of a trapezium are $(3a + 3)$ cm and $3a$ cm. The perpendicular distance between the parallel sides is $4a$ cm. If the area of the trapezium is 60cm^2 , find the value of a . (3 marks)
- 4 The figure below shows a region enclosed by a curve drawn on a 1 cm square grid.

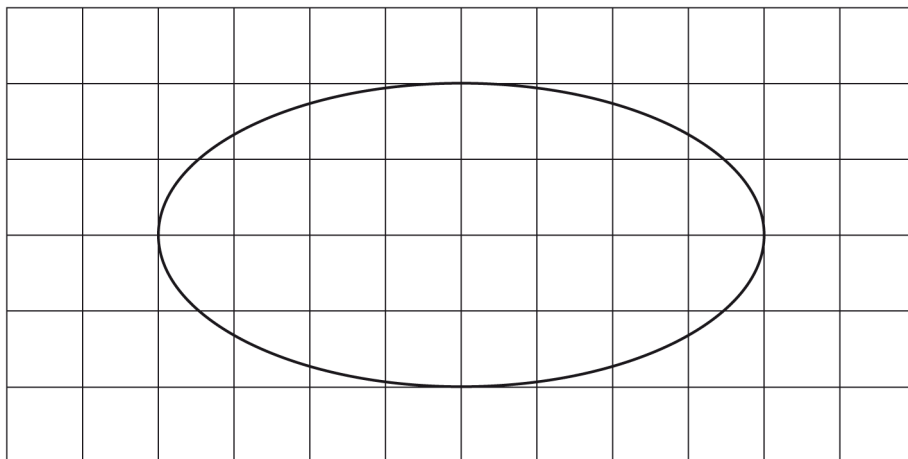

- Estimate the area of the region in square centimetres. (3 marks)
- 5 Makena deposited Ksh 48 000 in a fixed account in a bank. The bank paid a compound interest at a rate of 5% p.a. Calculate the interest earned at the end of 3 years. (3 marks)
- 6 Three vectors are such that $\mathbf{a} = 4\mathbf{i} + 5\mathbf{j}$, $\mathbf{b} = 8\mathbf{i} - 3\mathbf{j}$ and $\mathbf{c} = p\mathbf{i} + 3q\mathbf{j}$, where p and q are scalars. Given that $3\mathbf{a} - 2\mathbf{b} = \mathbf{c}$, determine the values of p and q . (3 marks)
- 7 Machine A can complete some work in 8 hours while machine B can complete the same work in 10 hours. The two machines were set to do the work at the same time. After 3 hours, machine B broke down. Determine the time taken by machine A to complete the remaining piece of work. (4 marks)

- 8 The figure below shows a curve which passes through point A(1,2).

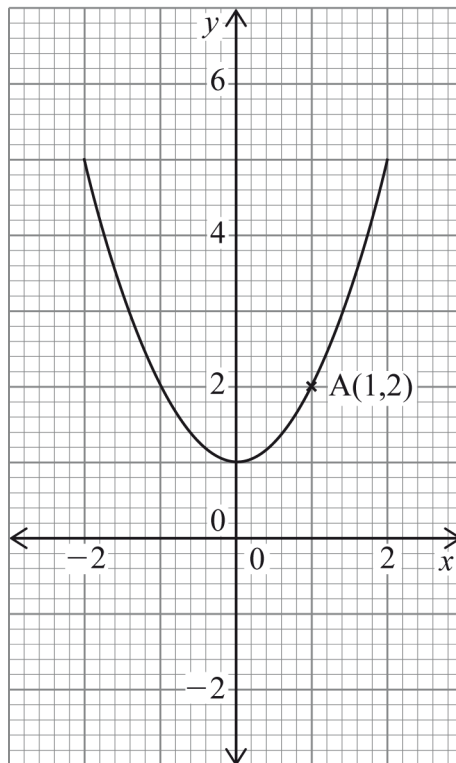

- Determine the instantaneous rate of change at A. (3 marks)
- 9 Solve the equation, $\tan(2\theta - 30)^\circ = \sqrt{3}$ for $0^\circ \leq \theta \leq 360^\circ$. (3 marks)
- 10 Two points, S and T are on the surface of the earth. The position of S is $(50^\circ \text{ S}, 138^\circ \text{ E})$ and that of T is $(22^\circ \text{ N}, 138^\circ \text{ E})$. Determine the shortest distance on the surface of the earth between S and T. (Take radius of the earth to be 6370 km and $\pi = \frac{22}{7}$) (3 marks)
- 11 Two matrices **M** and **N** are such that $\mathbf{MN} = \begin{pmatrix} 1 & 0 \\ 0 & 1 \end{pmatrix}$. Given that $\mathbf{M} = \begin{pmatrix} 8 & 3 \\ 4 & 2 \end{pmatrix}$, find **N**. (3 marks)
- 12 When Khisa walks for 5 hours at x km/h and Barongo walks for 6 hours at y km/h, they cover a total distance of 50 km. When Khisa walks for 7 hours at x km/h and Barongo walks for 5 hours at y km/h, they cover a total distance of 53 km. Determine the speeds x and y . (4 marks)
- 13 Four types of vehicles passed through a particular place on a road, on a certain day as shown in the table below.

Type of vehicle	Cars	Lorries	Motorcycles	Pick-ups
No. of vehicles	14	11	38	9

- Draw a pie-chart to represent the information. (3 marks)

- 14 The area of a parallelogram ABCD is 27 cm^2 . $A'B'C'D'$ is the image of ABCD under a transformation matrix $\begin{pmatrix} \frac{2}{3} & 0 \\ 0 & \frac{2}{3} \end{pmatrix}$. Find the area of $A'B'C'D'$. (3 marks)

- 15 The volume, $V \text{ cm}^3$, of a liquid in a vertical tube varies as the height, $h \text{ cm}$, of the tube. The table below shows values of h and the corresponding values of V .

$h \text{ cm}$	10	13	15	20	22	25
$V \text{ cm}^3$	12	15.6	18	24	26.4	30

- (a) On the grid provided, draw the graph of V against h . (2 marks)

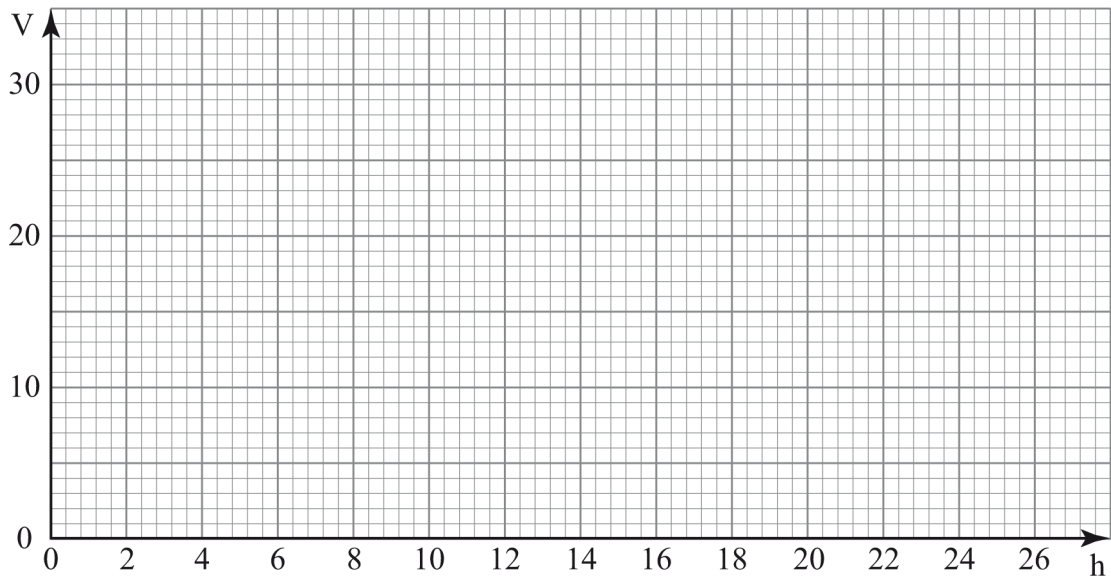

- (b) Use the graph to find the constant of proportionality. (1 mark)

- 16 Two chords AB and CD of a circle intersect internally at T. $AB = 15 \text{ cm}$, $TB = 3 \text{ cm}$ and $TD = 4 \text{ cm}$. Find the ratio in which T divides CD. (3 marks)

SECTION II (50 marks)

Answer any five questions from this section in the spaces provided.

- 17** A shop offered goods on both cash and hire purchase terms. The cash price of a water pump in the shop was Ksh 40 000.
- (a) Muiruri purchased the pump on hire purchase terms by paying a deposit equivalent to $20\frac{1}{2}\%$ of the cash price followed by 12 equal monthly instalments of Ksh 4800. Calculate:
- (i) the amount of deposit Muiruri paid; (2 marks)
 - (ii) the total hire purchase price; (2 marks)
 - (iii) the deposit as a percentage of the hire purchase price, correct to 1 decimal place; (2 marks)
 - (iv) the amount of the hire purchase price Muiruri paid above the cash price. (1 mark)
- (b) Bidii purchased an identical water pump whose hire purchase price was the same as that paid by Muiruri. Bidii paid 12 equal instalments of Ksh 4000. Calculate the deposit paid by Bidii as a percentage of the cash price. (3 marks)
- 18** A metal dealer cut a wire into pieces and arranged them in an ascending order of their lengths. The shortest piece was 0.5 m and the longest was 15 m. The difference in length of successive pieces was 25 cm.
- (a) Determine:
- (i) the total number of pieces cut; (2 marks)
 - (ii) the length of the tenth piece. (2 marks)
 - (iii) the total length of all the pieces. (2 marks)
- (b) Determine the number of pieces starting from the shortest, that will give a total length of 63 m. (4 marks)

- 19 (a) Complete the table below for the equation $y = x^2 + 3x - 5$. (2 marks)

x	-6	-5	-4	-3	-2	-1	0	1	2	3
y			-1				-5			

- (b) (i) On the grid provided, draw the graph of $y = x^2 + 3x - 5$ for $-6 \leq x \leq 3$.
(Use 1 cm to represent 1 unit on the horizontal axis and 2 cm to represent 5 units on the vertical axis) (3 marks)
- (ii) From the graph, estimate the values of x when $y = 0$. (2 marks)
- (c) (i) On the same grid, draw the line $y = 2x + 2$. (1 mark)
- (ii) From the graph determine the points of intersection of the curve $y = x^2 + 3x - 5$ and the line $y = 2x + 2$. (2 marks)

- 20 The table below shows marks scored by some students in a mathematics test.

Marks	30-39	40-49	50-59	60-69	70-79	80-89	90-99
No. of students	2	4	10	13	14	5	2

- (a) Calculate the mean mark. (3 marks)
- (b) On the grid provided, draw an ogive to represent the information. (4 marks)
- (c) Use the graph to determine:
- (i) the median; (2 marks)
- (ii) the position of the student who scored 75 marks. (1 mark)

- 21 The figure below is a quadrilateral ABCD. $AB = 6 \text{ cm}$, $BD = 9.2 \text{ cm}$ and angle $BDC = 40^\circ$.

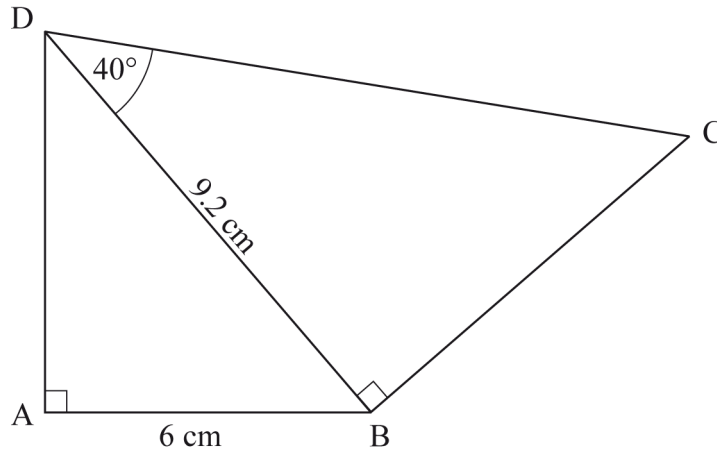

Calculate, correct to one decimal place:

- (a) the length AD; (2 marks)
 - (b) the size of angle ABD; (2 marks)
 - (c) the length BC; (2 marks)
 - (d) the area of triangle ACD. (4 marks)
- 22 Daudi goes to work by means of either a train, a bus or a motorcycle. On any given day, the probability of using a train is 0.3, the probability of using a bus is 0.5 and the probability of using a motorcycle is 0.2. When he uses a train, the probability of being punctual is 0.8. When he uses a bus, the probability of being punctual is 0.7 and when he uses a motorcycle, the probability of being punctual is 0.9.
- Calculate the probability that Daudi:
- (a) uses a train and is punctual for work; (2 marks)
 - (b) uses a bus and is late for work; (2 marks)
 - (c) is punctual for work; (3 marks)
 - (d) is late for work; (1 mark)
 - (e) uses either a train or a bus and is punctual for work. (2 marks)

23 The vertices of a triangle ABC are A(2, 4), B(2, 9) and C(6, 2).

(a) On the grid provided:

(i) draw triangle ABC;

(1 mark)

(ii) draw triangle A'B'C', the image of triangle ABC under a transformation

$$\mathbf{T} = \begin{pmatrix} -\frac{3}{5} & \frac{4}{5} \\ \frac{4}{5} & \frac{3}{5} \end{pmatrix}.$$

(3 marks)

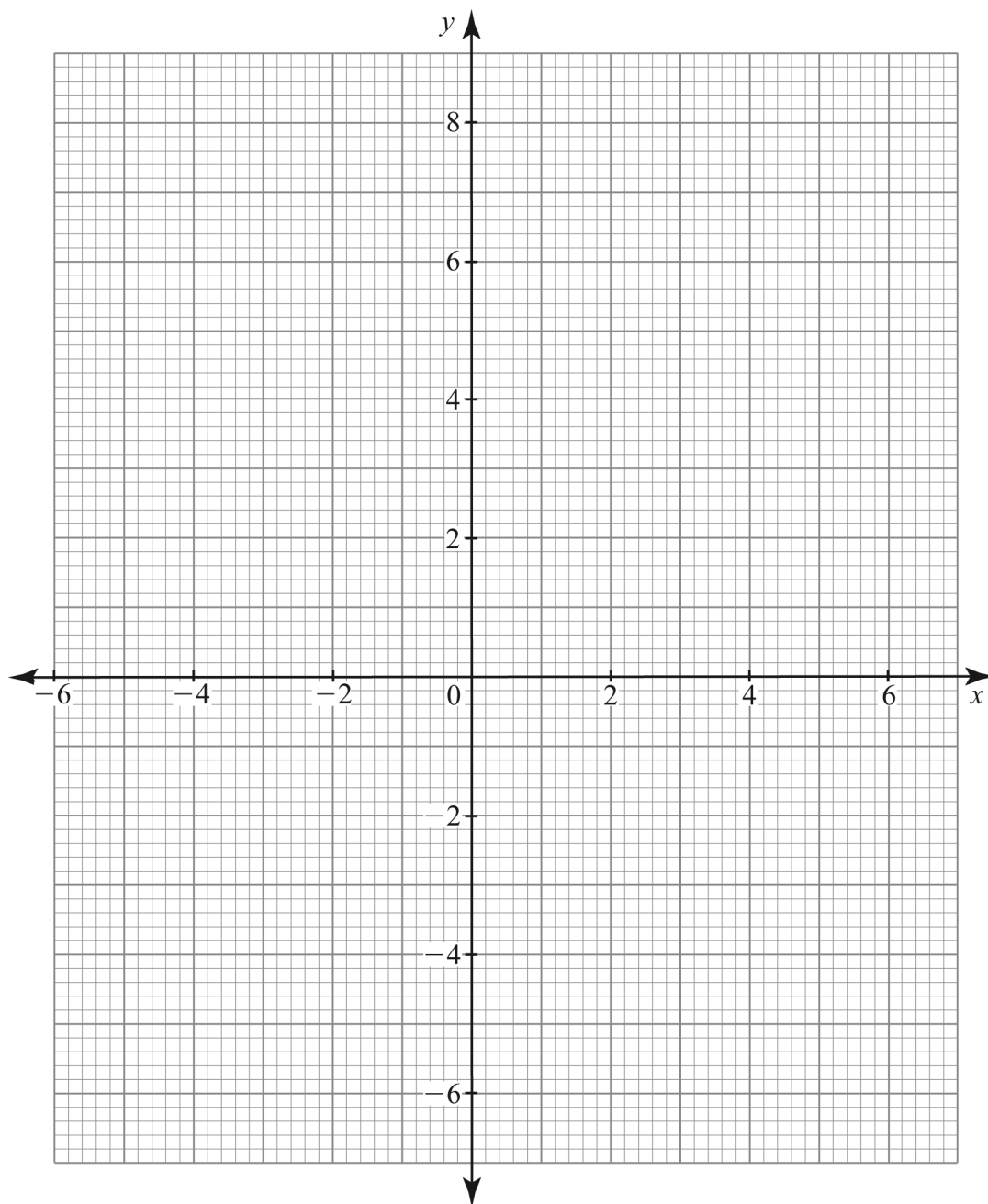

- (b) Describe transformation **T** fully. (2 marks)
- (c) The images of the vertices of triangle $A'B'C'$ under a transformation **H** are $A''(-2, -4)$, $B''(-6, -7)$ and $C''(2, -6)$.
- (i) On the same grid as in (a), draw triangle $A''B''C''$; (1 mark)
- (ii) determine the matrix of transformation **H**. (1 mark)
- (d) Find a single matrix of transformation that maps $A''B''C''$ onto ABC . (2 marks)

24 A fruit vendor carried out the following transactions in January 2014. On January 1st, she had a cash balance of Ksh 3250. On January 3rd, she bought 1200 oranges at Ksh 90 for every 12. On January 4th, she bought 150 pawpaws at Ksh 11 each, vegetables for Ksh 700 and paid Ksh 200 for transport. On January 5th, she sold 1175 oranges at Ksh 10 each. On January 6th, she sold 145 pawpaws at Ksh 12.50 each and vegetables for Ksh 1140. On January 8th, she paid a market fee of Ksh 150. On January 10th, she paid Ksh 400 to her assistant as wages. Prepare a single column cash account for the fruit vendor's transactions and balance it as at 11th January 2014. (10 marks)