

3.5 PHYSICS (232)

3.5.1 Physics Paper 1 (232/1)

SECTION A: (25 marks)

Answer **ALL** the questions in this section in the spaces provided.

- 1 A student measured the length of a wire four times using a metre rule and obtained the following readings: 18.6 cm; 18.5 cm; 18.6 cm and 18.5 cm. Determine the length the student should record. (2 marks)
- 2 **Figure 1** shows a magnified scale of a micrometer screw gauge.

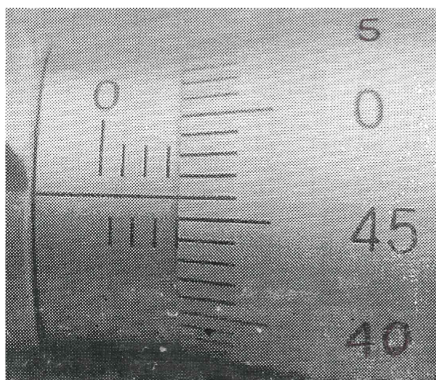

Figure 1

- Record the reading indicated. (1 mark)
- 3 State the reason why it is **not correct** to quote the weight of solid objects in kilograms. (1 mark)
- 4 **Figure 2** shows a section of a curved surface **ABCD**. Point **A** is higher than point **B** while **BCD** is horizontal. Part **ABC** is smooth while **CD** is rough. A mass **m** is released from rest at **A** and moves towards **D**.

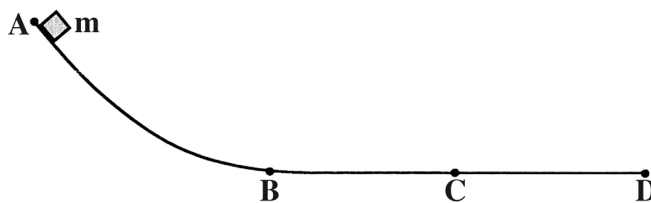

Figure 2

State the changes in the velocity of **m** between:

- (a) **B** and **C**; (1 mark)
- (b) **C** and **D**. (1 mark)

- 5 **Figure 3** shows two cylinders of different cross-sectional areas connected with a tube. The cylinders contain an incompressible fluid and are fitted with pistons of cross-sectional areas 4 cm^2 and 24 cm^2 .

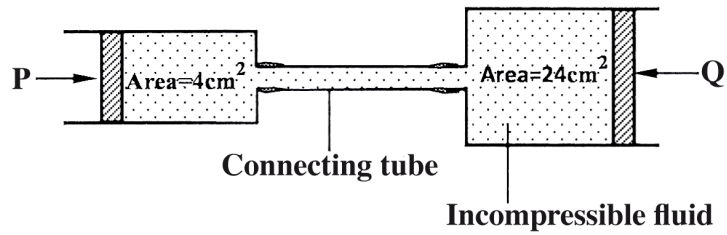

Figure 3

Opposing forces P and Q are applied to the pistons such that the pistons do not move. If the pressure on the smaller piston is 5 N cm^{-2} . Determine force Q . (2 marks)

- 6 An oil drop of volume $V \text{ m}^3$ introduced on the surface of water spreads to form a patch whose area is $A \text{ m}^2$. Derive an expression for obtaining the diameter, d of a molecule of oil. (2 marks)

- 7 **Figure 4** shows a source of heat placed at equal distances from two identical flasks X and Y containing air. The surface of X is painted black while Y is clear.

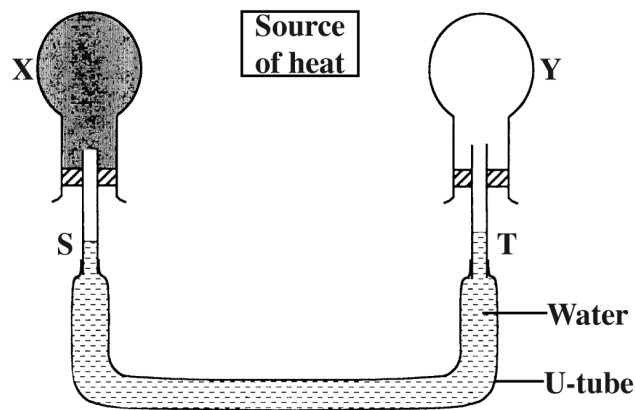

Figure 4

X and Y are linked by a U-tube filled with water whose levels S and T are initially the same. It is later observed that S falls while T rises. Explain this observation. (2 mark)

- 8 **Figure 5** shows a uniform rod 4 m long and of mass 2 kg. It is pivoted 1 m from one end and balanced horizontally by a string attached near the other end.

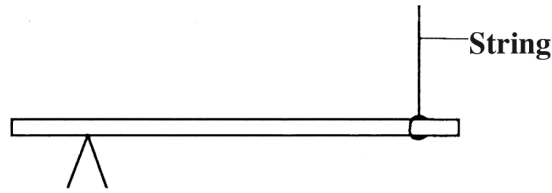

Figure 5

Determine the position where a mass of 5 kg should be placed on the rod so that the rod remains horizontal and the tension in the string is zero. (3 marks)

- 9 **Figure 6** shows two identical rods **JK** and **LK** connected with a hinge at **K**.

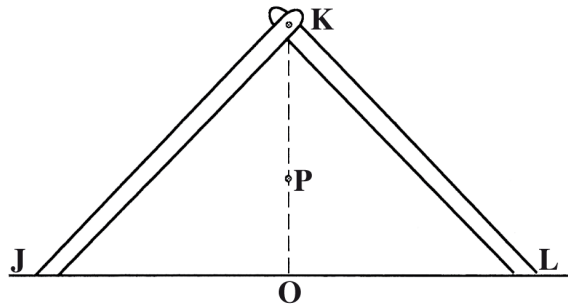

Figure 6

The position of the centre of gravity for the system is at **P**. The arrangement is now adjusted so that **J** and **L** move equal distances towards **O**. Sketch the new arrangement on the same diagram and mark the new position of the centre of gravity. (2 marks)

- 10 A light spiral spring extends by 4 mm when loaded with a weight W . The spring is connected in series with an identical spring. The combination is loaded with the weight W . Determine the extension of the combination. (2 marks)

- 11 **Figure 7** shows an incompressible fluid flowing through a pipe, A_1 and A_2 are the cross-sectional areas of the pipes in the larger section and smaller section of the pipe respectively, while v_1 and v_2 are speeds of the fluid at the two sections of the pipe.

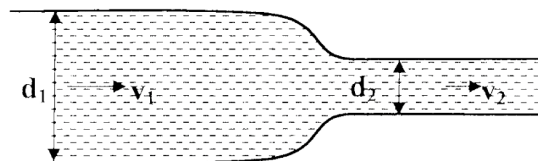
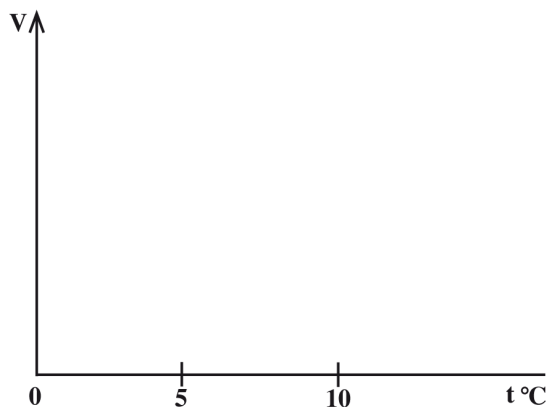

Figure 7

Derive an expression for the ratio of the speeds $\frac{v_2}{v_1}$ in terms of A_1 and A_2 . (2 marks)

- 12 On the axis provided, sketch the graph which shows the relationship between volume and temperature of a fixed mass of water in the temperature range 0°C to 10°C . (1 mark)



- 13 **Figure 8** shows a graph of the variation of temperature with time for a pure substance heated at a constant rate.

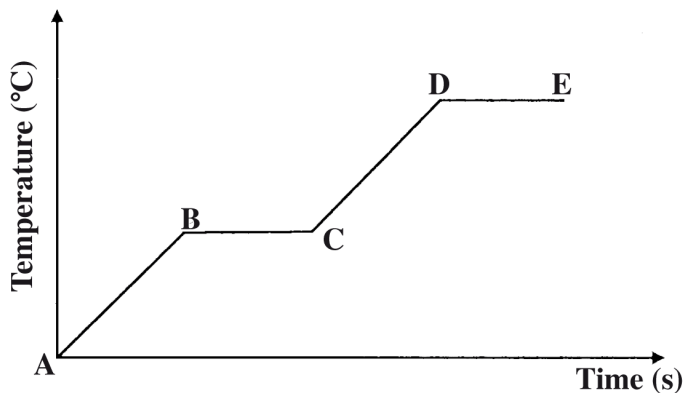

Figure 8

Assuming that heat transfer to the surroundings is negligible, state the changes observed on the substance in region:

- (a) **BC;** (1 mark)
- (b) **DE.** (1 mark)
- 14 In a smoke cell experiment to demonstrate Brownian motion, smoke particles are seen moving randomly. State the cause of the randomness. (1 mark)

SECTION B: (55 marks)

Answer *all* the questions in this section in the spaces provided.

- 15 **Figure 9** shows a velocity-time graph for the motion of a body of mass 2 kg.

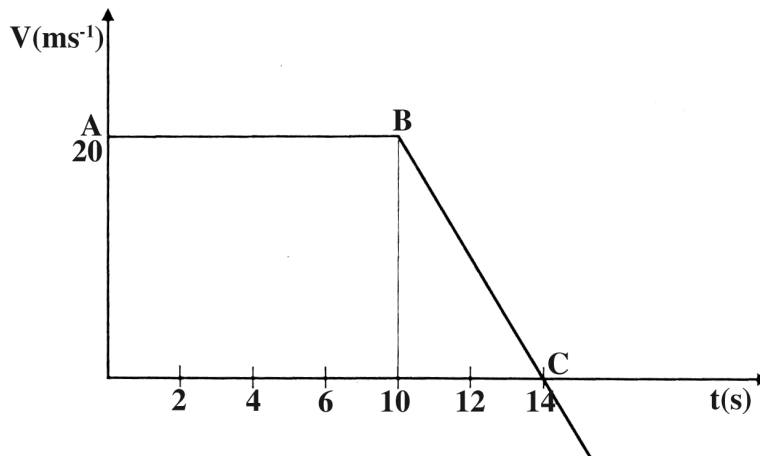

Figure 9

- (a) Use the graph to determine the:
- (i) displacement of the body after 8 seconds. (3 marks)
 - (ii) acceleration after point **B**; (3 marks)
 - (iii) force acting on the body in part (a) (ii). (3 marks)
- (b) Sketch a displacement-time graph for the motion from point **A** to **C**. (2 marks)

- 16 **Figure 10** shows a trolley of weight 20 N pulled by a force of 4 N from the bottom to the top of an inclined plane at a uniform speed.

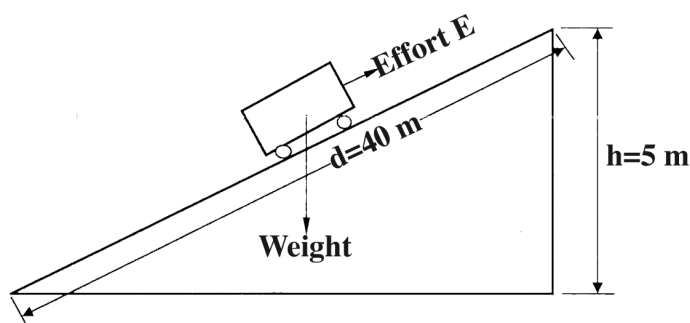

Figure 10

- (a) (i) State the value of the force acting downwards along the inclined plane. (1 mark)
- (ii) Explain how the value in part (a) (i) is obtained. (2 marks)

- (b) For the system, determine the:
- (i) mechanical advantage; (3 marks)
 - (ii) velocity ratio; (3 marks)
 - (iii) efficiency. (2 marks)
- 17** (a) A long horizontal capillary tube of uniform bore sealed at one end contains dry air trapped by a drop of mercury. The length of the air column is 142 mm at 17°C. Determine the length of the air column at 25°C. (3 marks)
- (b) The pressure of the air inside a car tyre increases if the car stands out in the sun for some time on a hot day. Explain the pressure increase in terms of the kinetic theory of gases. (3 marks)
- (c) In an experiment to determine the specific latent heat of vapourization of water, steam of mass 10 g at 100°C is passed into 100 g of water initially at 20°C in a container of negligible heat capacity. The temperature of the water rises to 70°C.
(Take the specific heat capacity of water as $4.2 \times 10^3 \text{ J kg}^{-1} \text{ K}^{-1}$ and the boiling point of water as 100°C)
- (i) Determine the specific latent heat of vapourization of water. (4 marks)
 - (ii) State **two** sources of error in this experiment. (2 mark)
- 18** (a) When a bus goes round a bend on a flat road, it experiences a centripetal force. State what provides the centripetal force. (1 mark)
- (b) State the purpose of banking roads at bends. (1 mark)
- (c) A student whirls a stone of mass 0.2 kg tied to a string of length 0.4 m in a vertical plane at a constant speed of 2 revolutions per second.
(Take acceleration due to gravity g as 10 ms^{-2})
- (i) State **two** forces acting on the stone when it is at the highest point. (2 marks)
 - (ii) Determine the:
 - I angular velocity of the stone; (3 marks)
 - II tension in the string when the stone is at the highest point; (3 marks)

- 19 **Figure 11** shows a test-tube whose cross-sectional area is 2 cm^2 partially filled with lead shot floating vertically in water.

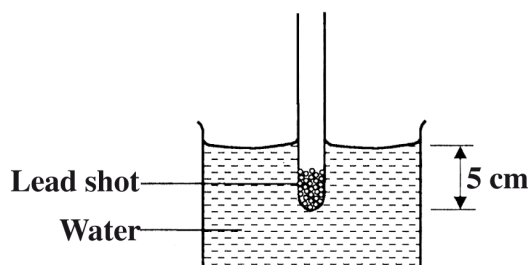

Figure 11

(Take gravitational acceleration as 10 ms^{-2} and density of water ρ_w as 1 g cm^{-3})

- (a) (i) Determine the:
- I volume of the water displaced; (2 marks)
 - II weight of water displaced. (3 marks)
- (ii) State the combined weight of the test-tube and the lead shot. (1 mark)
- (iii) Determine the length of the test-tube that would be submerged in a liquid of density 0.8 g cm^{-3} . (4 marks)
- (b) The set up in **figure 11** can be used as a hydrometer to measure densities of liquids. State how such a hydrometer would be improved to measure small differences in densities of liquids. (1 mark)

SECTION A (25 marks)

Answer *all* the questions in this section in the spaces provided.

1 **Figure 1** shows two parallel rays from a distant object passing through a convex lens:

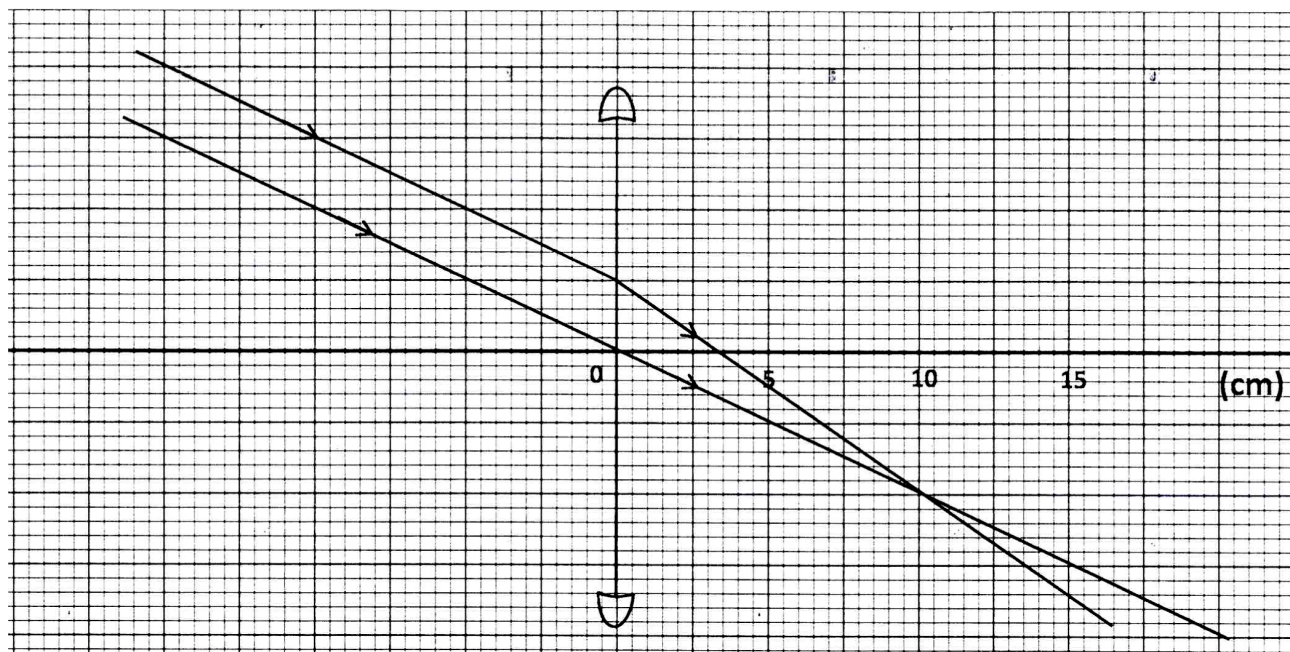

Figure 1

- (a) Indicate on the diagram, the position of the principal focus of the lens. (1 mark)
 - (b) Determine the focal length of the lens. (1 mark)
- 2 State the effect of decreasing the distance between the plates of a parallel plate capacitor on the capacitance. (1 mark)
- 3 **Figure 2** shows circular waves originating from the principal focus F of a concave mirror and moving towards the mirror.

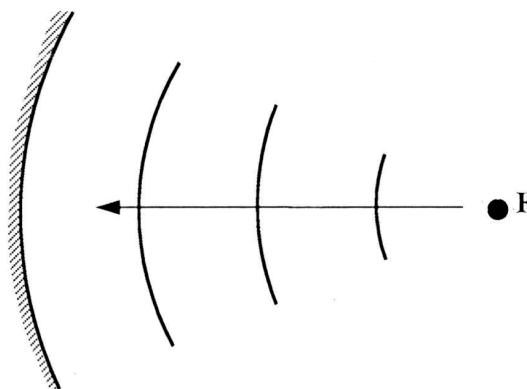

Figure 2

Complete the diagram to show the reflected waves.

(1 mark)

- 4 The frequency of an electromagnetic wave is 4.0×10^6 Hz. Determine its wavelength. (take speed of light as 3.0×10^8 ms⁻¹). (3 marks)
- 5 **Figure 3** shows a nail on which a wire is to be wound to make an electromagnet.

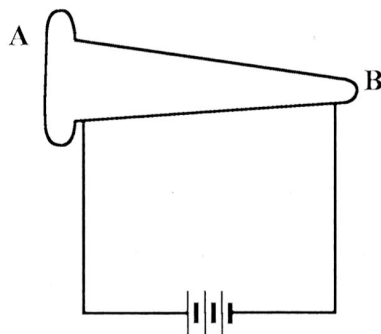

Figure 3

- By drawing, show how the wire should be wound around the nail so that end A becomes a north pole and end B a south pole. (1 mark)
- 6 It is observed that when the cap of an uncharged electroscope is irradiated with light of high frequency, the leaf of the electroscope rises. Explain this observation. (3 marks)
- 7 **Figure 4** shows the magnetic field pattern around two bar magnets placed side by side.

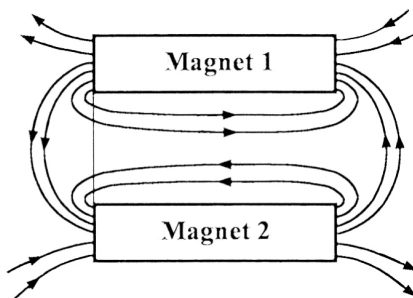

Figure 4

Indicate on the diagram the poles of each magnet. (1 mark)

8 **Figure 5** shows a graph of current against voltage for a semiconductor diode.

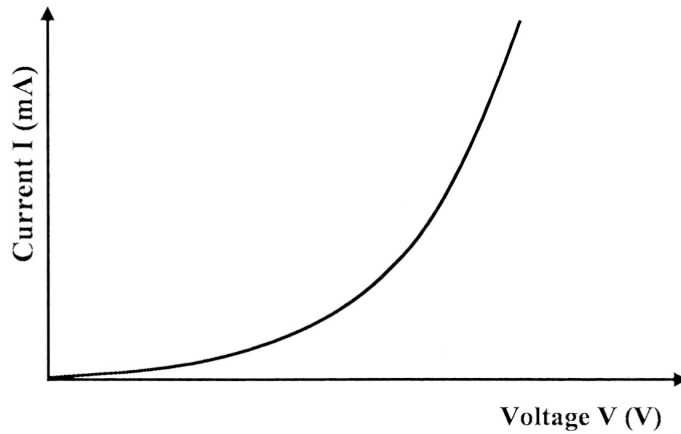

Figure 5

In the space provided, draw a circuit diagram that may be used to obtain values needed to draw the graph in **figure 5**. (3 marks)

9 Radium undergoes radioactive decay by emitting an alpha particle to form a daughter nuclide Q as in the reaction:



Determine the values of:

(a) x (1 mark)

(b) y (1 mark)

10 State **two** uses of a charged gold leaf electroscope. (2 marks)

11 The anode of an x-ray tube becomes hot when the tube is in use. State the reason for this. (1 mark)

12 Draw a ray diagram to show how a ray of light may be totally internally reflected two times in an isosceles right - angled glass prism. (*Assume that the critical angle of glass is 42°*) (2 marks)

13 The current of electrons hitting the screen of a cathode ray oscilloscope is 2.0×10^{-4} A . Determine the number of electrons that strike the screen each second. (*take charge of an electron as 1.6×10^{-19} C*). (3 marks)

SECTION B (55 marks)

Answer *all* the questions in this section in the spaces provided.

14 (a) **Figure 6** shows a simple electric bell circuit.

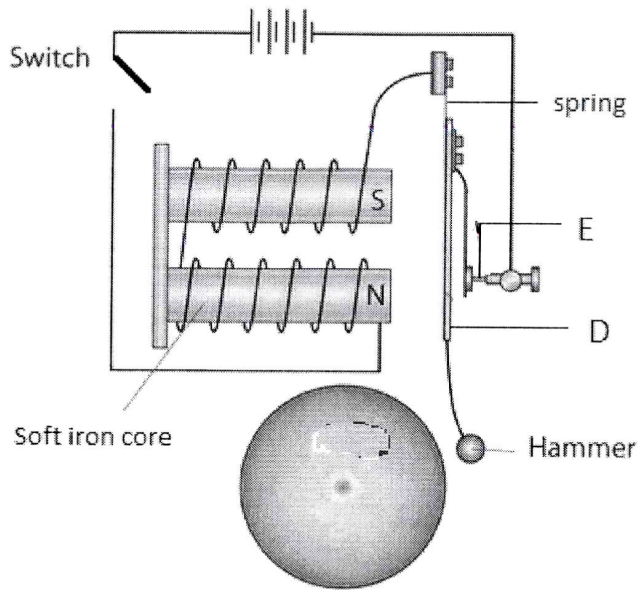

Figure 6

(i) Name the parts labelled:

(I) **D** (1 mark)

(II) **E** (1 mark)

(ii) When the switch is closed, the hammer hits the gong repeatedly. Explain why:

(I) the hammer hits the gong. (2 marks)

(II) the hammer hits the gong repeatedly. (3 marks)

(b) An electric bulb is rated 60 W, 240 V. Determine:

(i) the current that flows through it when it is connected to a 240 V supply. (3 marks)

(ii) the resistance of the bulb. (3 marks)

15 (a) One of the causes of energy loss in a transformer is heating in the coils when current flows. State:

(i) the reason why the current causes heating. (1 mark)

(ii) how the heating can be minimized. (1 mark)

(b) The input voltage of a transformer is 240 V and its output is 12 V. When an 80 W bulb is connected across the secondary coil, the current in the primary coil is 0.36 A. Determine:

(i) the ratio $\frac{N_P}{N_S}$ of the transformer, (where N_P is the number of turns in the primary coil and N_S is the number of turns in the secondary coil) (3 marks)

(ii) the power input of the transformer. (3 marks)

(iii) the power output of the transformer. (1 mark)

(iv) the efficiency of the transformer. (2 marks)

16 (a) **Figure 7** shows resistors R_1 and R_2 connected in parallel. Their ends are connected to a battery of potential difference V volts.

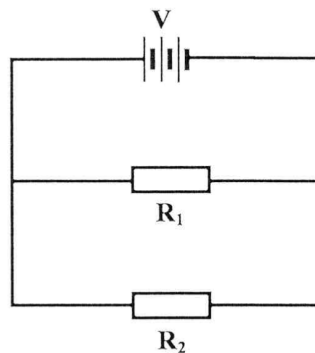

Figure 7

(i) In terms of V , R_1 and R_2 , write an expression for:

(I) current I_1 through R_1 . (1 mark)

(II) current I_2 through R_2 ; (1 mark)

(III) total current I in the circuit. (1 mark)

(ii) Show that the total resistance R_T is given by $R_T = \frac{R_1 R_2}{R_1 + R_2}$. (3 marks)

- (b) **Figure 8** shows a negatively charged rod placed near an uncharged conductor resting on an insulating support.

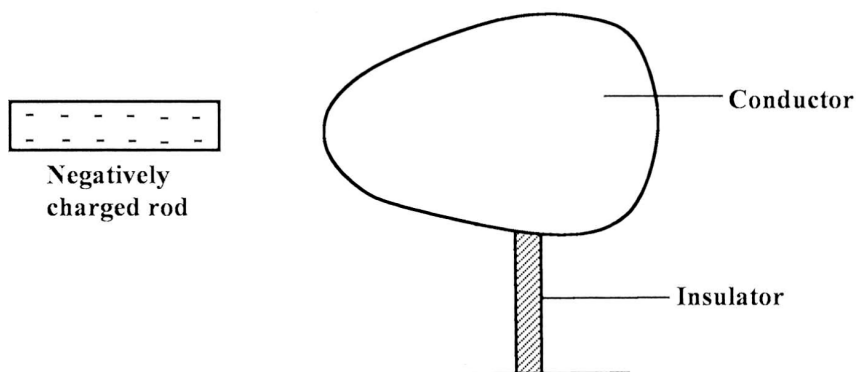

Figure 8

- (i) Show the charge distribution on the conductor. (2 marks)
- (ii) State the effect:
- (I) of momentarily touching the conductor with a finger while the charged rod is still near the conductor. (1 mark)
- (II) on the charge distribution of withdrawing the negatively charged rod after momentarily touching the conductor. (1 mark)
- (iii) In the space provided, sketch a diagram to show how the charge in ii (II) would have been distributed if the conductor was a sphere. (1 mark)

- 17 (a) **Figure 9** shows two speakers S_1 and S_2 which produce sound of the same frequency. They are placed equidistant from a line AB and a line PQ . (PQ is perpendicular to line AB).

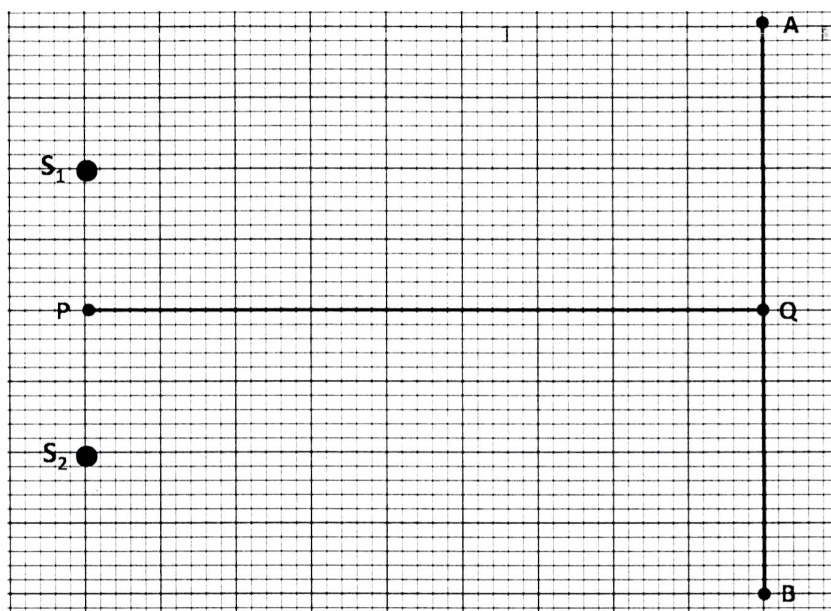

Figure 9

- (i) A student walking from A to B hears alternating loud and soft sounds. Explain why at some point the sound heard is soft. (2 marks)
- (ii) The student now walks along line PQ . State with reason the nature of the sound the student hears. (3 marks)
- (b) **Figure 10** shows sound waves in air produced by a vibrating tuning fork. R is an air molecule on the path of the waves.

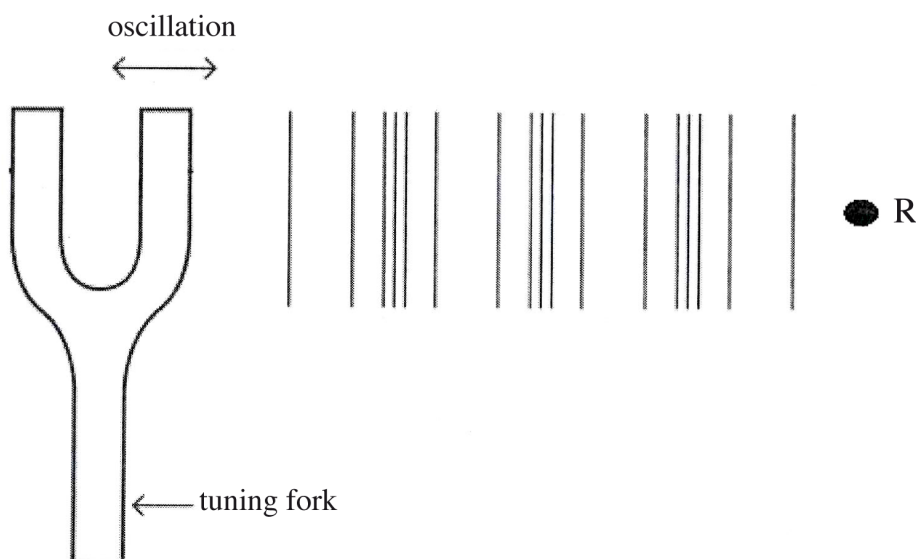

Figure 10

- (i) Using a line, indicate on the diagram a distance d equal to one wavelength of the wave. (1 mark)

- (ii) In the space provided, show with an arrow the direction of motion of the air molecule R as the waves pass. (1 mark)
- (iii) Explain the reason for the answer in (ii). (2 marks)

18 **Figure 11** shows an object placed 10 cm in front of a concave mirror whose radius of curvature is 40 cm.

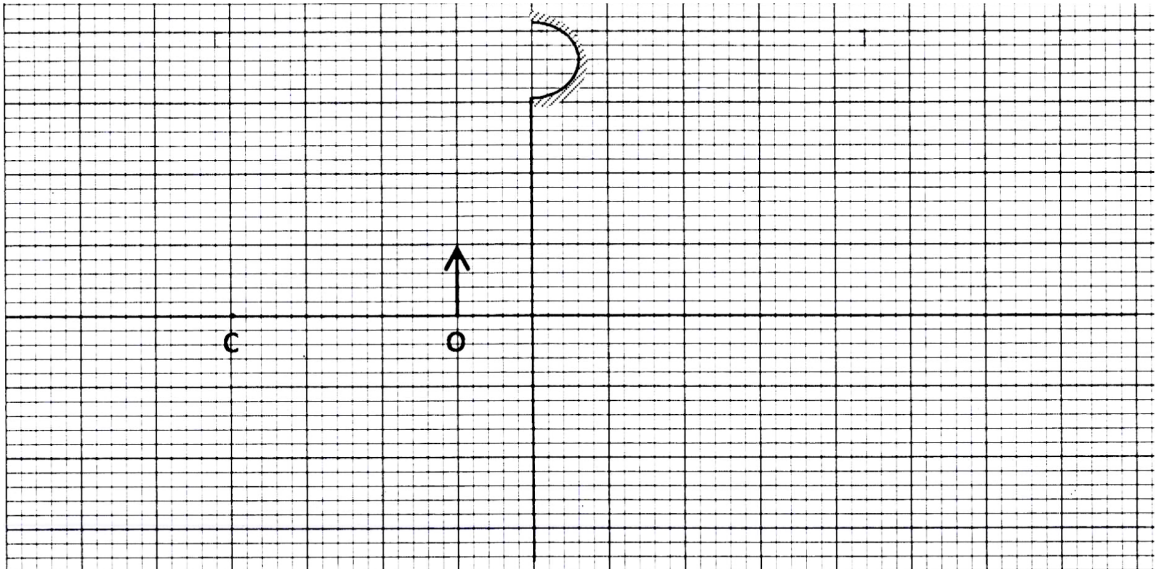

Figure 11

- (a) (i) On the same figure, draw a ray diagram to show the position of the image formed. (3 marks)
- (ii) Use the ray diagram to determine:
- (I) the image distance. (1 mark)
- (II) the magnification. (3 marks)
- (iii) State where the position of the image would be if the object had been placed at the principal focus. (1 mark)
- (b) Draw a ray diagram to show the formation of a partially dark shadow and a totally dark shadow during the eclipse of the sun. (3 marks)

3.5.3 Physics Paper 3 (232/3)

Question 1

PART A

You are provided with the following:

- a metre rule
- 3 optical pins
- 2 small wooden blocks
- a stop watch
- a stand, a boss and clamp
- a piece of sellotape

Proceed as follows:

- Using the two wooden blocks, clamp two optical pins about 4 cm apart in the stand so that they project out of the blocks in a horizontal plane.
- Using a piece of sellotape, attach the third optical pin across the metre rule at a distance $x = 10$ cm from the 50 cm mark. Now suspend the metre rule on the two clamped pins so that it can swing freely in a vertical plane with the third pin as the axis. (See **figure 1**)

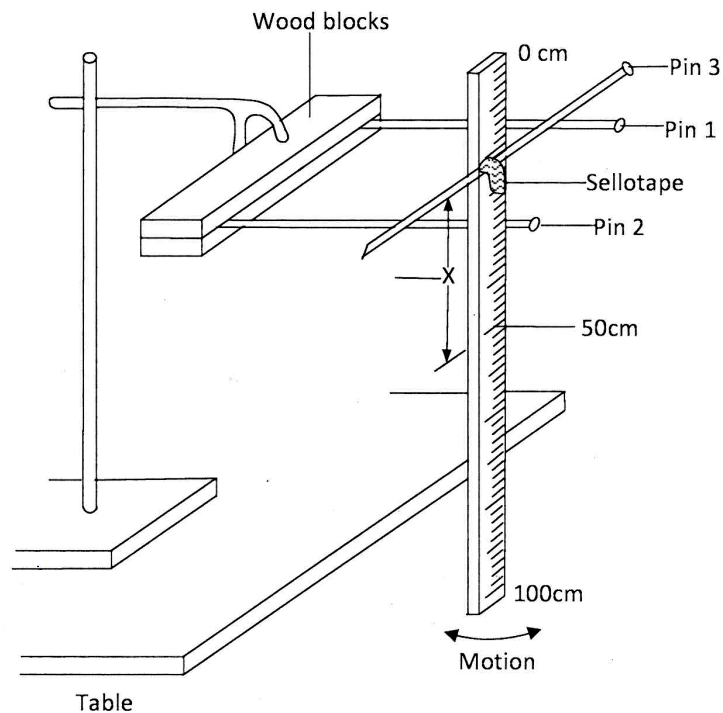

Figure 1

- (c) Displace the lower end of the metre rule slightly and let it oscillate as shown in the **figure 1**. Measure and record in table 1 the time t (s) for 20 oscillations. (**Correct to one decimal place**.)
- (d) (i) Repeat the procedure in (b) and (c) for the values of x shown in table 1.
- (ii) For each value of x shown in the table, determine the period T (s), **correct to two decimal places**, and complete the table. (The period T is the time for one complete oscillation).

Table 1

Distance X (cm)	10	14	18	22	26	30
Time t (s)						
Period T (s)						
T^2 , X correct to 1 decimal place						
X^2						

- (e) On the grid provided, plot a graph of T^2X (y-axis) against X^2 (origin not required). (5 marks)
- (f) From the graph, determine:
- (i) the slope S of the graph. (3 marks)
- (ii) the value of constant r given that:
 $rS = 39.5$ (2 marks)

PART B

You are provided with the following:

- a converging mirror
- a rectangular piece of manilla paper
- a half meter rule
- a stand, boss and clamp
- a dropper
- liquid Q

Proceed as follows:

- (g) (i) Using the wooden blocks clamp the manilla paper in the stand so that it projects out of the blocks in a horizontal plane, about 30 cm above the bench.

(ii) Place the mirror on the bench so that its centre is vertically below the free end of the manilla paper.

(h) With your eye vertically above the free end of the manilla, observe its inverted diminished image appearing as in **figure 2**.

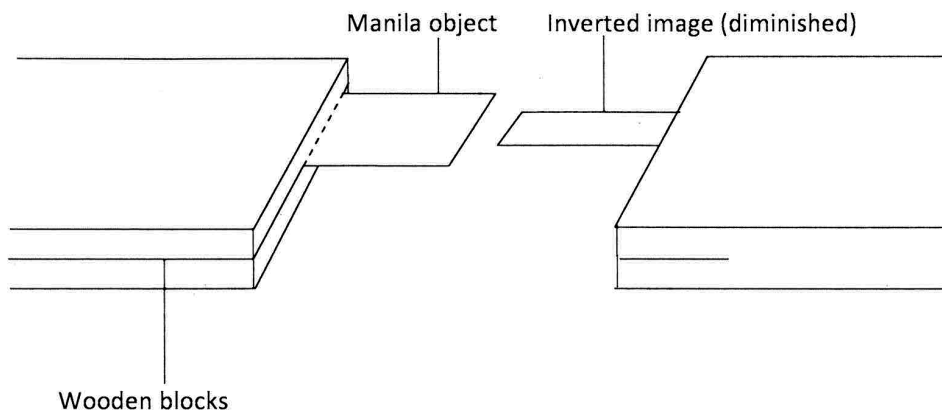

Figure 2

(i) Now adjust the height of the manilla vertically above the centre of the mirror until its width and that of the inverted image are equal as in **figure 3**.

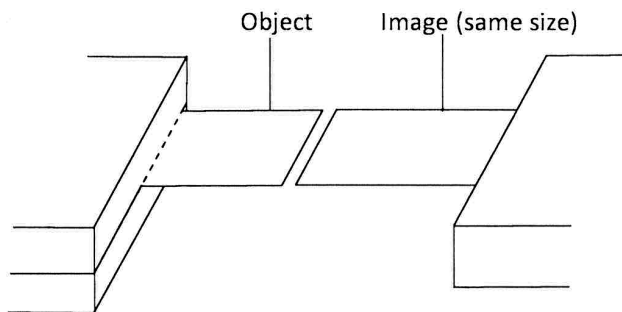

Figure 3

Measure and record the distance L_1 between the manilla paper and the bench.

$L_1 = \dots\dots\dots$ cm (1 mark)

(j) Using the dropper provided put some liquid Q on the mirror so that its surface is about 3 cm in diameter. Repeat part (i). Measure and record the distance L_2 between the manilla paper and the bench.

$L_2 = \dots\dots\dots$ cm (1 mark)

(k) Determine constant k given that:

$L_1 = kL_2$ (2 marks)

Question 2

You are provided with the following:

- four $10\ \Omega$ resistors
 - a resistance wire labelled S mounted on a half metre rule
 - a resistance wire AB mounted on a metre rule
 - two dry cells and a cell holder
 - a centre zero galvanometer G
 - 8 connecting wires each with a crocodile clip at one end
 - a jockey
 - a micrometer screw gauge
 - a switch
- (a) Set up the circuit as in **figure 4** in which R is near A and S is near B. (R is a $10\ \Omega$ resistor or an appropriate combination of 10-ohm resistors).

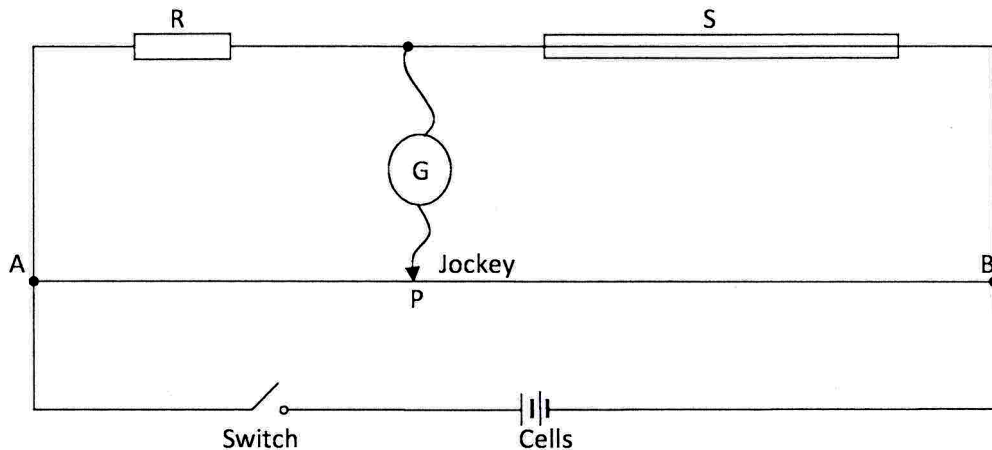

Figure 4

- (b) Starting with a single $10\ \Omega$ resistor as R, close the switch. Using the jockey tap wire AB briefly near end A and observe the deflection on the galvanometer. Now tap the wire near end B and again observe the deflection of the galvanometer. (*The two deflections should be in opposite directions*)
- (c) Still with the $10\ \Omega$ resistor as R, tap at various points along wire AB to obtain a point P at which the galvanometer shows zero deflection. Measure and record in table 2 the length L (m) between A and P. (**Record L correct to 3 decimal places**)
- (d) Repeat part (c) to obtain L for other values of R shown in table 2. (6 marks)
- (e) Determine:
- (i) $\frac{1}{L}$ for all the values of L correct to 2 decimal places. (1 mark)

- (ii) $\frac{1}{R}$ for all values of R correct to 3 decimal places. (1 mark)

R(Ω)	5	10	15	20	25	30
L(m)						
$\frac{1}{L}$						
$\frac{1}{R}$						

- (f) On the grid provided, plot a graph of $\frac{1}{L}$ (y-axis) against $\frac{1}{R}$ (origin not required). (5 marks)

- (g) (i) Determine the slope n of the graph. (3 marks)

- (ii) State the unit of n. (1 mark)

- (h) Using the micrometer screw gauge, measure and record the diameter D of wire S in metres.

D = m. (1 mark)

- (i) Determine the value of constant k given that

$$4k = \pi D^2 n \quad (3 \text{ marks})$$