

4.14 ART AND DESIGN (442)

4.14.1 Art & Design Paper 1 (442/1)

SECTION A (20 marks)

1. (a) Art and design forms a basis for every subject in the curriculum.
The statement express the fact that art and design:

- Enhances understanding through use of teaching and learning aids.
- Helps develop creativity in other subjects.
- Used for illustrations, drawing, making models etc.

Any 1 x 2 = (2 marks)

- (b) **Missing colours in the triad.**

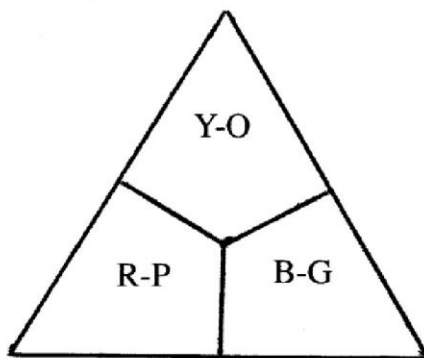

Red - purple
Blue - Green

1 x 2 = (2 marks)

- (c) **Recede:** applies to cool colours blue, green, purple they appear to draw back/ move back / grow less or smaller; diminish. (1 mark)

Advance: applies to warm colours, red, yellow, orange, appear to project / standout / move forwards. (1 mark)

- (d) **Mood portrayed in the artwork:**

- sadness;
- thoughtfulness.

(1 mark)

- (e) **The two picture making techniques are**

- montage;
- collage.

1 x 2 = 2 marks

- (f) **Types of balance:** Radial balance;
Asymmetrical balance.

1 x 2 = (2 marks)

- (g) **Dabbing:** To apply by tapping gently with a brush, rug, or a sponge.

Airbrushing: application of paint by use of a spray gun or can or atomizer with compressed air and paint.

1 x 2 = (2 marks)

(h) **Two roles of packaging design:**

- Marketing / advertising / aesthetic appeal / identify.
- Protect the contents / product from damage, contamination.
- Distinguish the content / product.

Any 2 x 1 = (2 marks)

(i) **Slip mould:** Uses liquid clay.

Press mould uses moist solid clay.

2 x 1 = (2 marks)

(j) Print making process used to create half tones is referred to as mezzotint. (1 mark)

(k) **Shellac:** easy to remove after printing, and screen re-used.

Varnish: difficult to remove from the mesh and therefore the screen cannot be re-used.
1 x 1 = 1 mark

(l) **Importance of spacers in ornament production:**

- used to separate bands of colour.
- keeps ornaments rigid and in shape.
- Create a variety / enhance aesthetic appeal/design

Any 1 x 1 = 1 mark

Total = 20 marks

SECTION B (25 marks)

2.

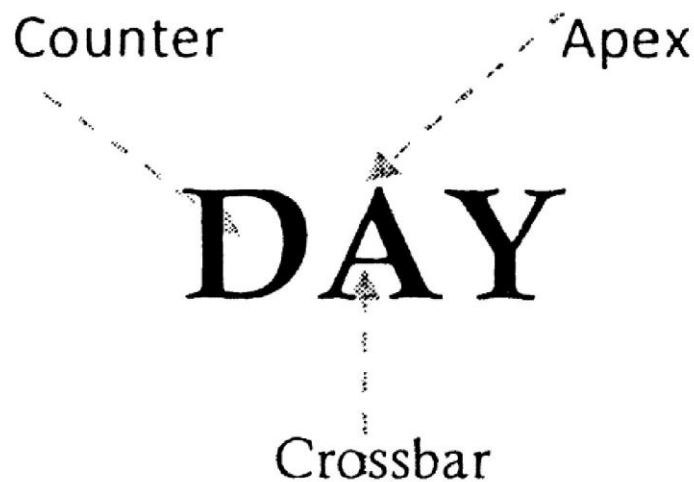

Precision and spacing	1 x 1 =	1 mark
Uppercase	1 x 1 =	1 mark
Labelling	3 x 1 =	3 marks
Total	=	5 marks

3. (a) (i) **Caricature:** It's a portrait that exaggerates or distorts the basic essence of a person or thing to create an easily identifiable visual likeness.

OR

A drawing of a character or person deliberately distorted or parts exaggerated for satirical effect.

(1 mark)

- (b) (ii) **Characteristics of caricature:**

- Exaggerated / distorted features with easily identifiable visual likeness.
- It's drawn as a single image (not in panels).
- Very simplified

1 x 2 = 2 marks

- (c) (iii) **Significance of caricature to visual communication:**

- It's the briefest and sharpest way of stating a criticism
- It addresses the audience to the lacking and improper odds, evils and parts of society.

1 x 2 = (2 marks)

Total = 5 marks

4.

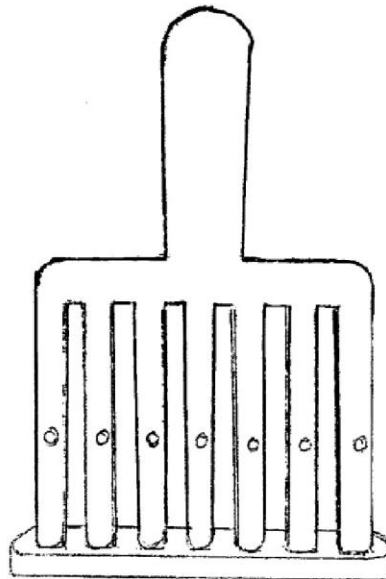

Technique : weaving 1 mark

Tool Rigid heddle loom 1 mark

- Functions:
- spaces out the warp threads 1 mark
 - creates sheds 1 mark
 - used to beat down weft threads 1 mark
 - Holds the warp threads 1 mark
 - Determines the width of the fabric 1 mark

Total = 5 marks

5. Steps involved in open firing of clay articles:

- (i) Dig a wide shallow open pit.
- (ii) Arrange twigs, dry leaves, pieces of wood at the bottom of the pit.
- (iii) Place/stack the clay articles on top and cover with more leaves, twigs and pieces of wood, until a mould is built up over the pieces.
- (iv) Once stacking process is finished, the pile can be lit around the edges and left to smolder for several hours or days.
- (v) Monitor the firing and keep feeding the fire until the articles are fully fired, bury the pit in earth to cut off oxygen supply.

5 x 1 = 5 marks

6. Factors that determine the choice of materials in ornament making

- (i) Availability of the materials
- (ii) Cost of the materials
- (iii) Durability of the materials
- (iv) Function of the ornament
- (v) Style/design/shape of the ornament

5 x 1 = 5 marks

SECTION B (15 marks)

7. (a) (i) Worm's eye view:

- The object is above the eye level.
- The horizon is low.
- The observer cannot see the top of the object.

Any 2 x 1 = 2 marks

(ii) Normal eye view:

- The object is at the eye level.
- The horizon is at the same level with the object.
- The observer can neither see the top or bottom of the object.

Any 2 x 1 = 2 marks

(iii) Bird's eye view:

- The object is below the eye level.
- The horizon is high.
- The observer cannot see the bottom of the object.

Any 2 x 1 = 2 marks

Total = 6 marks

(b) A desk drawn in two point perspective

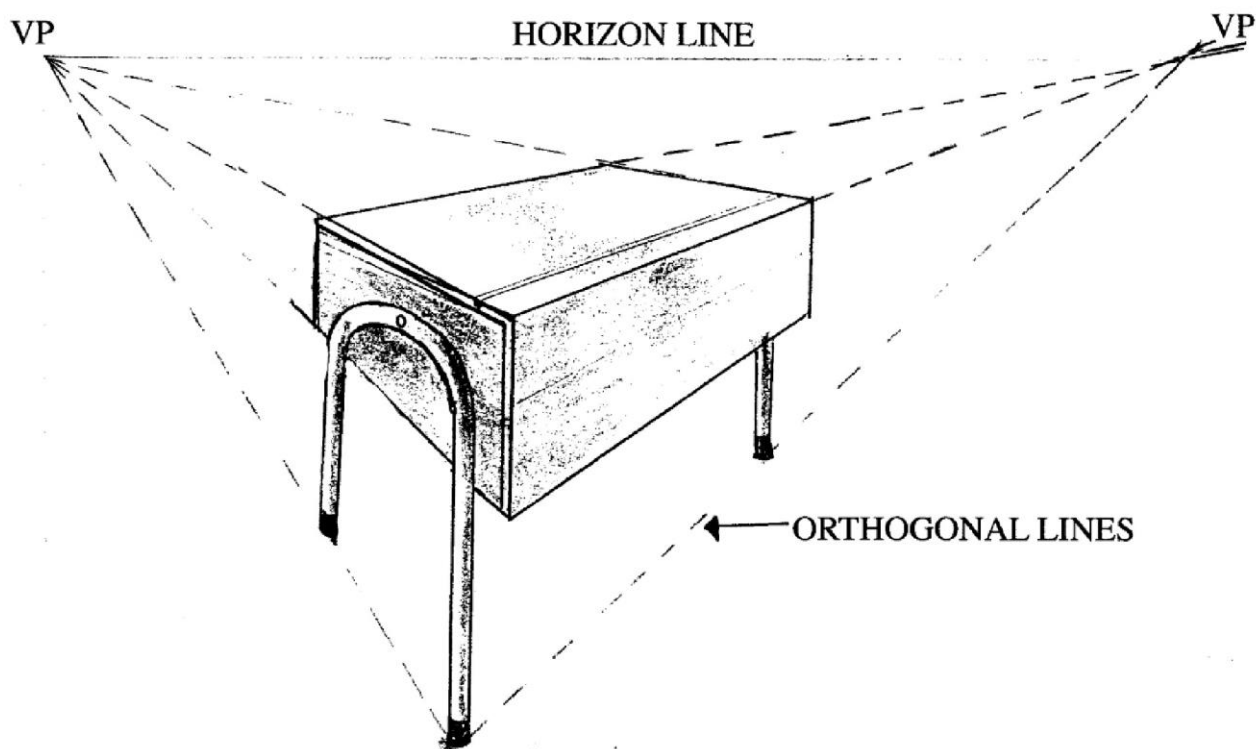

Labelling

- Horizon line / eye level (label) 1 mark
 - orthogonal / perspective lines 2 marks
 - Accuracy (desk/lines)(desk in two point perspective) 4 marks
 - Vanishing points 2 marks
- Total 9 marks**

8. (a) Technique - casting 1 mark

(b) (i) **Modelling**

Merits

- The material is malleable/pliable
- Easy to work with / manipulate
- Both addition and subtraction methods are applicable while creating forms
- Material can be re-used/recycled
- Durable in material form and easy to handle
- Allows for a wide variety of designs / details Any 5 x 1 = 5 marks

Limitations

- The work has to be fired for durability
- Clay work is fragile and needs careful handling
- Limited in size
- Placement - limit to indoor only
- Dried under controlled conditions. Any 2 x 1 = 2 marks

(ii) **Construction**

Merits

- Design derives spontaneous inspiration from the material
- A variety of materials used
- Materials easily available i.e found objects

- Size of sculpture not limited
- The framework (armature) of the sculpture ensures stability and strength.
- Suitable for both indoor and outdoor display.

Any 5 x 1 = 5 marks

Limitations

- Limited in creating intricate details.
- Leans towards abstraction.
- Requires different joining (construction) skills
- Requires high level skills to produce because of the different technical processes involved.

Any 2 x 1 = 2 marks

Total = 15 marks

9. (i) Sketch of motif as it would appear on block



Motif in Reverse

1 mark

- (ii) Labelling of parts - positive - Black parts
Negative - white parts

1 mark

1 mark

- (iii) Block printing process

- Sketch design
- Work out colour scheme / colour separation
- Transfer design for the 1st colour onto the block
- Cut out/scoop/gauge the negative parts
- Prepare the ink by rolling it out on a glass pane
- Apply ink onto the block by use of a roller
- Place the paper on the printing surface and put registration marks
- Place the inked block face down on the printing paper or block face-up and printing paper on top
- Apply pressure evenly to bring out impression
- Remove the block/paper and leave the print to dry
- Clean the block and transfer the design for the 2nd colour
- Repeat the process for the 2nd colour.

1 mark each x 12 = 12 marks

Total = 15 marks

4.14.1 Art & Design Paper 2 (442/2)

ALTERNATIVE A: DRAWING/PAINTING

QUESTIONS 1 & 2

1. INTERPRETATION	MARKS
(i) Relevance of subject matter to theme	08
(ii) Appropriateness of mood/atmosphere	04 14
(ii) Correct dimensions (measurements)	02
2. COMPOSITION	
(i) Appropriate use of space	04
(ii) Appropriate format	04
(iii) Unity/rhythm/balance	08 30
(iv) Originality/creativity/imagination/	08
(v) Rendition of perspective (aerial/linear)	06
3. FORM/STRUCTURE	
(i) Definition of forms	10
(ii) Capture of actions/mood	06
(iii) Articulation of posture and features	06 32
(iv) Proportions of forms in relation to each other and whole	06
(v) Texture/pattern	04
4. TONE/COLOUR	
(i) Tonal value to create volume/depth	06
(ii) Harmony/contrast	06
(iii) Competency in use of media (workmanship)	04 20
(iv) Appropriateness to subject matter	04
5. PRESENTATION	
(i) Neatness	02
(ii) Appropriate finish	02 04
TOTAL	100 MARKS

SECTION B: GRAPHIC DESIGN

QUESTION 3 & 4

		MARKS	
1.	INTERPRETATION		
	(i) Subject matter:	02	
	(ii) Requirements: understanding of graphic process- correct information/contents of signage/brochure	06	
	(iii) Correct dimensions	02	
	(iv) Appropriate format	02	16
	(v) Mood/symbolism in relation to subject matter	04	
2.	COMPOSITION		
	(i) Layout of pictorial forms/letters	08	
	(ii) Spacing of letters, words and lines	10	
	(iii) Originality/creativity/imagination	10	32
	(iv) Rhythm/unity/balance	04	
3.	FORM/STRUCTURE		
	(i) Definition of forms (pictorial/letters)	12	
	(ii) Proportion of forms (pictorial/letters) in relation to each other and whole	10	30
	(iii) Appropriateness of forms/(pictorial/letters to function.	08	
4.	COLOUR		
	(i) Appropriate colour	06	
	(ii) Harmony/contrast	06	12
5.	PROFESSIONAL SKILLS		
	(i) Precision	06	
	(ii) Neatness	02	10
	(iii) Presentation/finish	02	
	TOTAL		100 MARKS