

3.20.2 Electricity Paper 2 (448/2)

1 STATION 1

Using the components, materials and equipment provided, carry out the following tasks:

- (a) Connect the circuit as shown in **figure 1**. Let the examiner check your work. (7 marks)

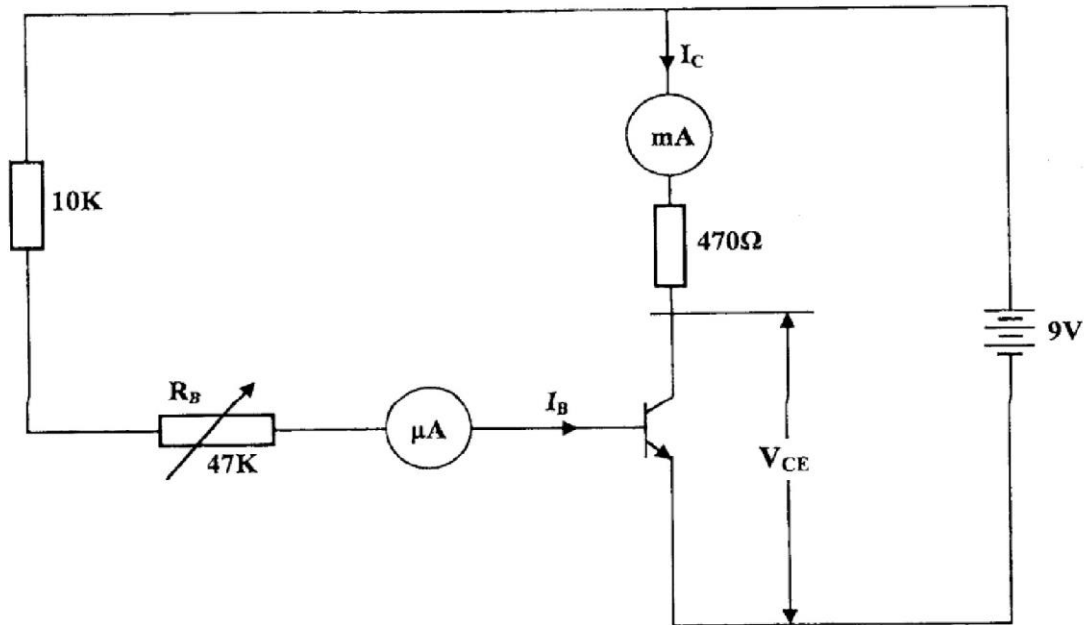

Figure 1

- (b) Vary the base resistance R_B to obtain each of the base current I_B values shown in **table 1**. For each value of I_B , measure and record in the table the corresponding values of V_{CE} and I_C . (6 marks)

Table 1

$I_B (\mu A)$	$V_{CE} (V)$	$I_C (mA)$
200		
220		
240		
260		
280		
300		

- (c) Using the values in table 1:
- determine the current gain β when $I_B = 240 \mu A$. (2 marks)
 - plot a graph of I_C against V_{CE} . (5 marks)

2 STATION 2

Using the tools, equipment and materials provided, fabricate the saddle bracket shown in **figure 2**. (20 marks)

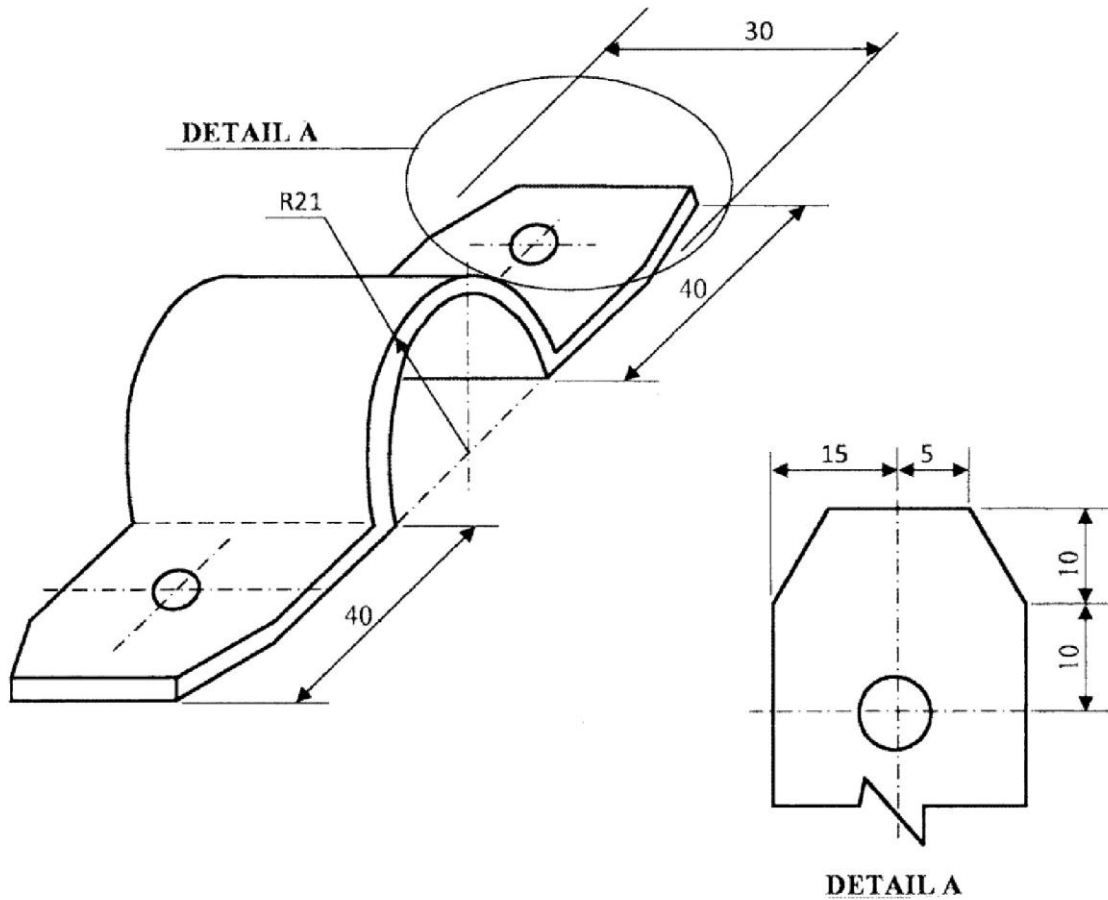

Figure 2

3 STATION 3

Using materials, components and equipment provided, perform the following tasks:

- (a) Connect the circuit shown in **figure 3**. Let the examiner check your work.

(5 marks)

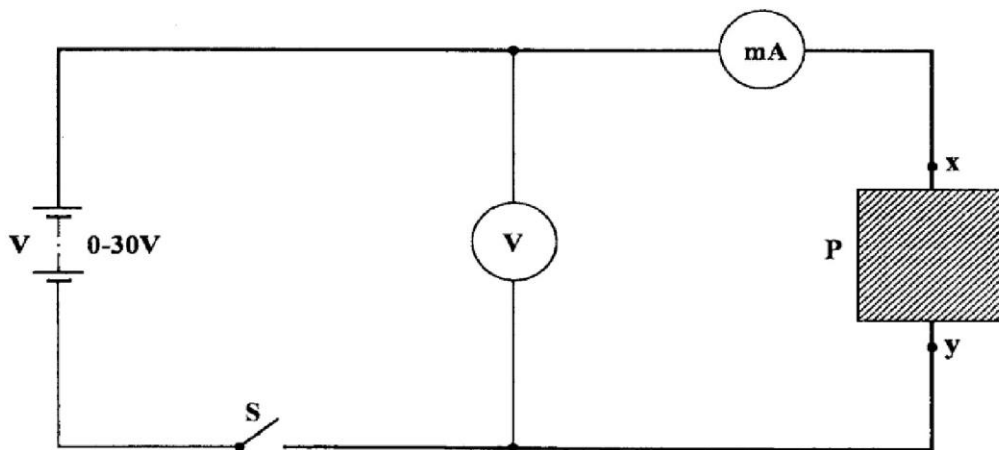

Figure 3

- (b) Close the switch S and adjust the power supply to obtain voltage values shown in **table 2**. For each voltage obtained, measure and record in the table the corresponding value of current.

Table 2

Voltage, V (V)	2.0	5.0	8.0	12.0	16.0	22.0
Current, I (mA)						

(6 marks)

- (c) Using the values in **table 2**, draw the graph of current I against voltage V. (5 marks)
- (d) Determine the slope of the graph. (3 marks)
- (e) Name the electrical quantity expressed by the slope of the graph and name its unit. (1 mark)

4 STATION 4

Figure 4 shows the block diagram of the electronic circuit.

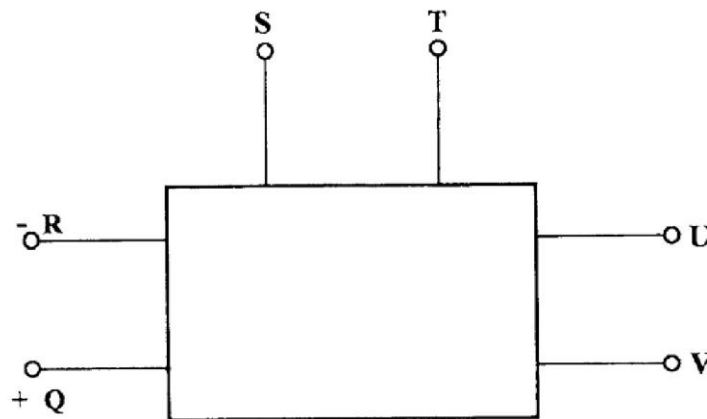

Figure 4

Use the equipment and accessories provided to perform the following tasks.

- (a) With the power supply off and output knob at minimum, connect the equipment to the terminals on circuit P as follows:-
- Q and R, a voltmeter;
 - S and T, a voltmeter;
 - U and V, a milliammeter;
 - Q and R, power supply.

(Let the examiner check your work)

(4 marks)

- (b) Turn the power supply ON. Adjust the power supply voltage to obtain the voltage values, E_s shown in **Table 3**.

In each case, measure and record in table 3 the corresponding values of Load Voltage V_L and load current I_L .

Table 3

ES	V_{LOAD}	I_{LOAD}
1		
3		
6		
7		
10		
12		

(9 marks)

(c) Plot a graph of load voltage V_L against power source voltage E_s . (5 marks)

(d) State **one** application of the circuit P and give the reason for your answer. (2 marks)

5 STATION 5

Using PVC sheathed wiring, complete the installation shown in **figure 5**, such that the bell is operated from either A or B. (20 marks)

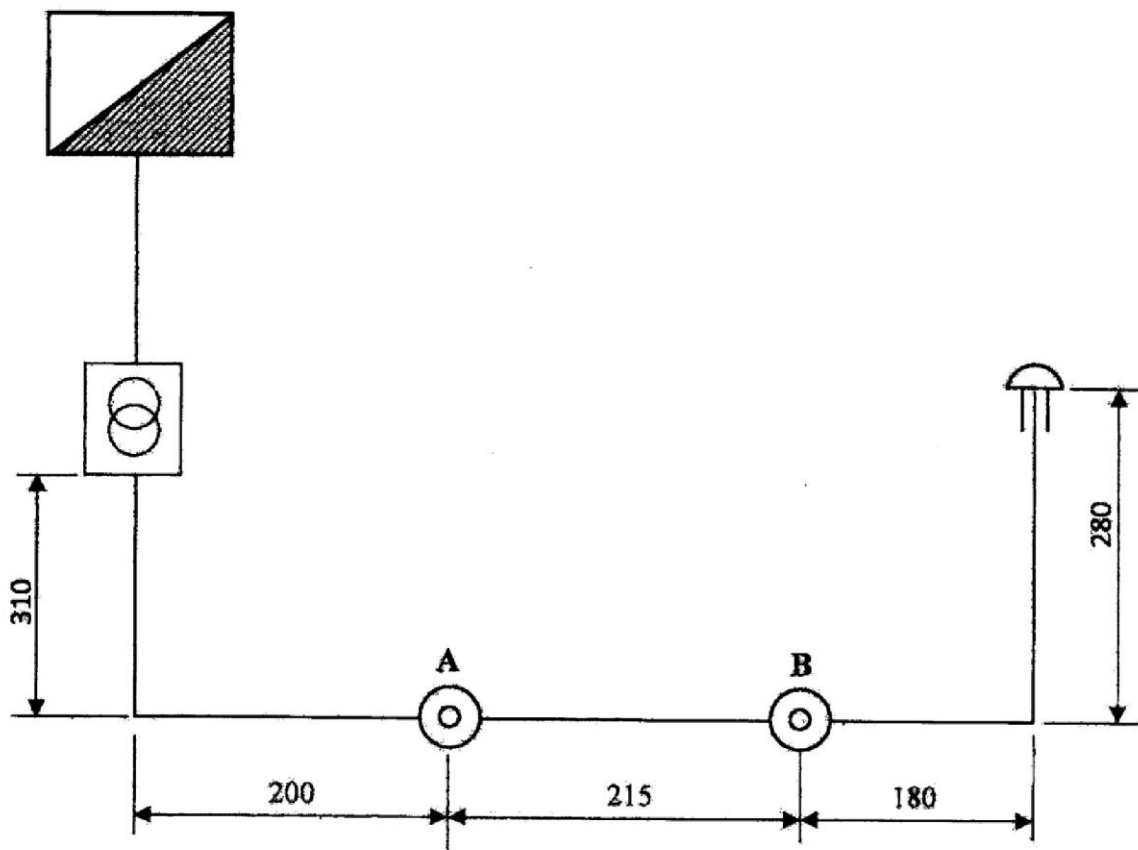

Figure 5