

3.19 POWER MECHANICS (447)

3.19.1 Power Mechanics Paper 1 (447/1)

SECTION A (40 marks)

Answer *all* the questions in this section in the spaces provided.

- 1 (a) Define a “machine”. (1 mark)
- (b) State **two** reasons for having a first aid box in a vehicle. (2 marks)
- 2 (a) State **three** functional characteristics of a road wheel. (3 marks)
- (b) (i) Define a business plan. (1 mark)
- (ii) List **four** components of a business plan. (2 marks)
- 3 (a) A piston ring fitted in a cylinder has a gap clearance of 0.25 mm at room temperature. Explain what happens to the gap clearance when the ring is hotter than the cylinder. (2 marks)
- (b) Name the parts labelled A, B, C and D on the fastener in **figure 1**. (2 marks)

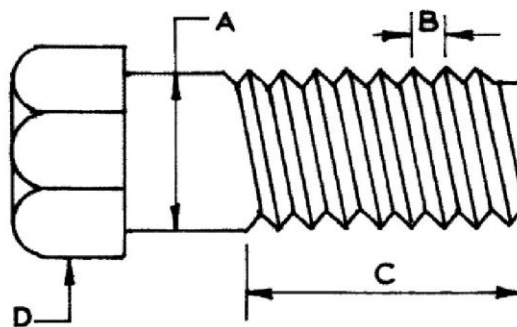

Fig.1

- A
- B
- C
- D

- 4 (a) State the purpose of each of the following tools:
- (i) reamer; (1 mark)
- (ii) tap. (1 mark)

- (b) State **two** factors to consider when selecting a spanner for a motor vehicle repair task. (2 marks)
- 5 (a) State **four** applications of a photovoltaic cell. (2 marks)
- (b) List **four** types of lighting circuits of a motor vehicle. (2 marks)
- 6 (a) State **two** functions of the final drive. (2 marks)
- (b) Sketch the symbols used to represent the following in assembly drawings: (2 marks)
- (i) a square;
- (ii) a countersunk.
- 7 Outline **three** properties of soldering flux. (3 marks)
- 8 (a) List **four** types of manual steering gearboxes. (2 marks)
- (b) Name **four** types of springs used in vehicle suspension systems. (2 marks)
- 9 State **four** purposes of lubricating oil additives. (4 marks)
- 10 Outline **eight** components of a pressurized water cooling system of a motor vehicle. (4 marks)

SECTION B (60 marks)

Answer **question 11** on A_3 paper and any other **three** questions from this section in the spaces provided. Candidates are advised to spend **not more than 25 minutes** on question 11.

11 Figure 2 shows a machine block drawn in isometric projection.

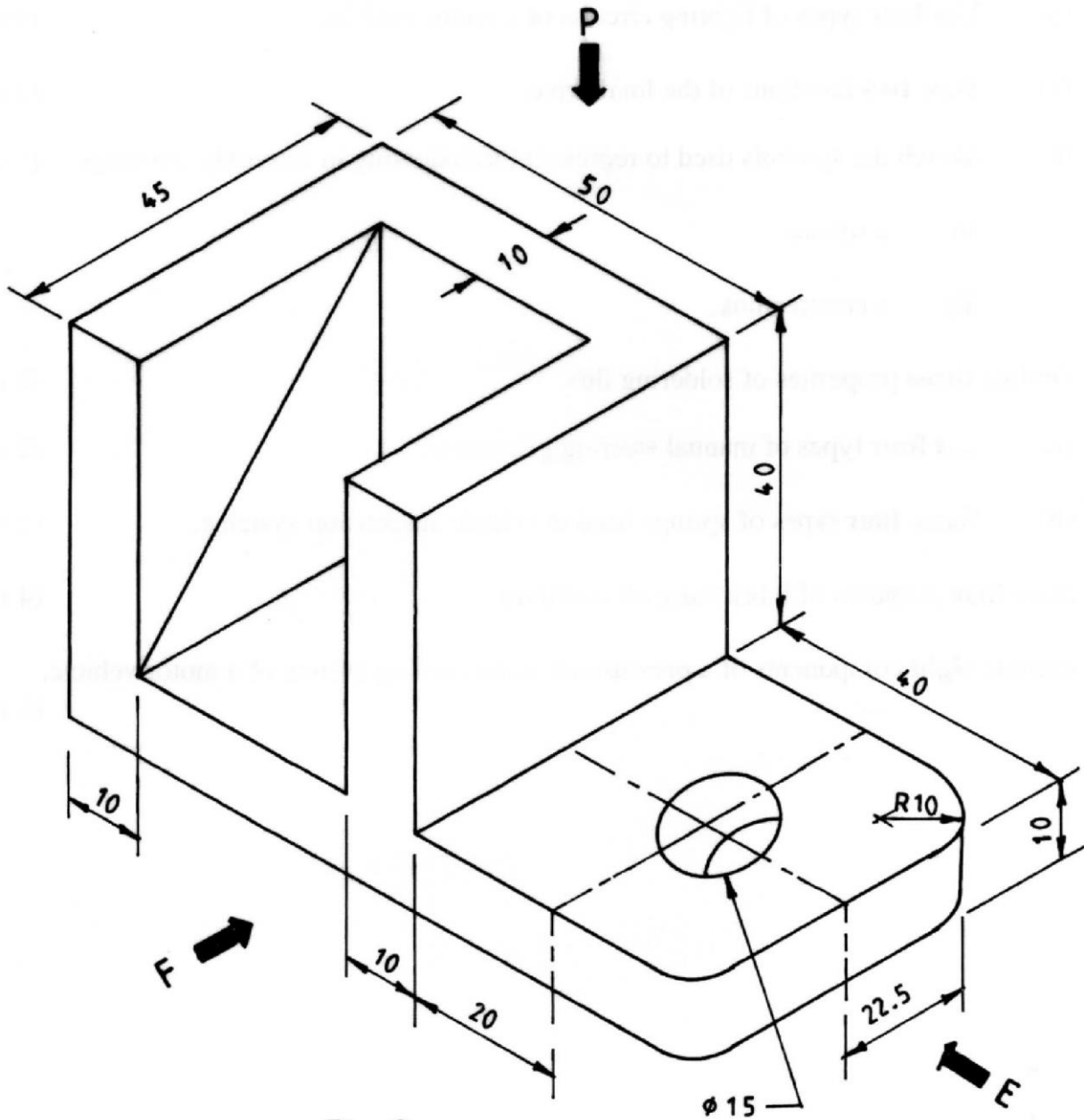

Fig. 2

Draw **full size** in 3rd angle projection the following views:

- (a) front elevation in direction "F";
- (b) end elevation in direction "E";
- (c) plan.

(15 marks)

12 The figure 3 shows a disc brake assembly:

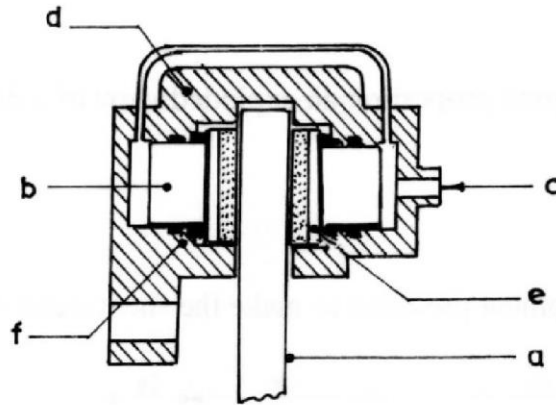

Fig. 3-disc brake assembly

- (a) Name the parts labelled a, b, c, d, e and f. (3 marks)
- (b) Explain the operation of the system when:
- (i) brakes are applied; (5 marks)
 - (ii) brakes are off. (7 marks)
- 13 (a) State **three** functions of the exhaust system. (3 marks)
- (b) (i) State the cause of back pressure in an exhaust system. (1 mark)
- (ii) Explain the consequence of excessive back pressure. (2 marks)
- (c) With the aid of a labelled cross-sectional sketch, describe the construction of an absorption silencer. (9 marks)
- 14 (a) State **three** operational differences between petrol and diesel engines. (3 marks)
- (b) Compare a petrol and a diesel engine of the same size with reference to: (12 marks)
- (i) weight;
 - (ii) running costs;
 - (iii) emissions;
 - (iv) thermal efficiency;
 - (v) compression ratio;
 - (vi) operating temperatures.
- 15 (a) State **four** functions of oil in an engine. (4 marks)
- (b) Describe the following lubrication methods used in different engines: (11 marks)
- (i) splash feed;
 - (ii) pressure feed.