

3.4 MATHEMATICS ALTERNATIVE B (122)

3.4.1 Mathematics Alt.B Paper 1 (122/1)

SECTION I (50 marks)

Answer all the questions in this section in the spaces provided.

1. (a) Express 4732 in terms of its prime factors. (1 mark)
- (b) Find the smallest positive number that must be multiplied by 4732 to make it a perfect square. (1 mark)

2. Three people Juma, Weru and Njeri went round a circular racing track, 3.12 km long. They all started from the same point and moved in the same direction. Juma walked at 48 m per minute, Weru ran at 120 m per minute while Njeri cycled at 156 m per minute.

If they started travelling at 0700 h, find the time when they were first together again. (3 marks)

3. Evaluate $\frac{-9 \div +3 \times +4 - ^{-}2}{(+15 - ^{-}5) \div ^{-}4}$ (3 marks)

4. Without using a calculator, evaluate $\frac{\frac{3}{4} \text{ of } 8\frac{1}{5} - 4\frac{1}{2}}{1\frac{1}{4} \div 1\frac{7}{8} \times 3\frac{3}{10}}$ (3 marks)

5. Use logarithms to evaluate:

$$\frac{84.56 \sqrt[3]{0.0027}}{0.045} \quad \text{correct to 4 significant figures.} \quad (4 \text{ marks})$$

6. The diagram below represents a cube of side 10 cm from which a cuboid measuring x cm by x cm by 10 cm is removed as shown.

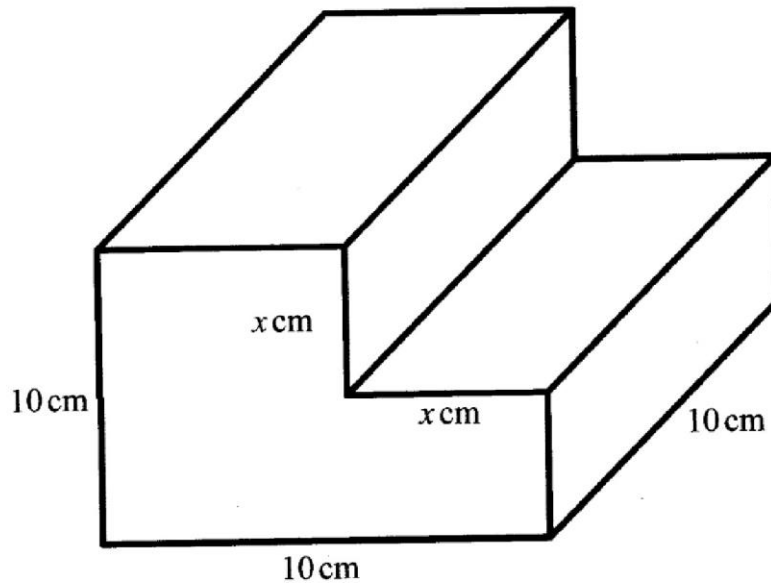

Write an expression in terms of x , for the surface area of the remaining solid. (3 marks)

7. A cylindrical tank 1.4 m in diameter contains 3234 litres of water. Find the depth, in metres, of the water. (Take $\pi = \frac{22}{7}$). (3 marks)

8. The figure below represents a quadrilateral ABCD in which angle $DAB = 60^\circ$, angle $BCD = 30^\circ$ and $BC = DC = 40$ cm. Side $AB = AD$.

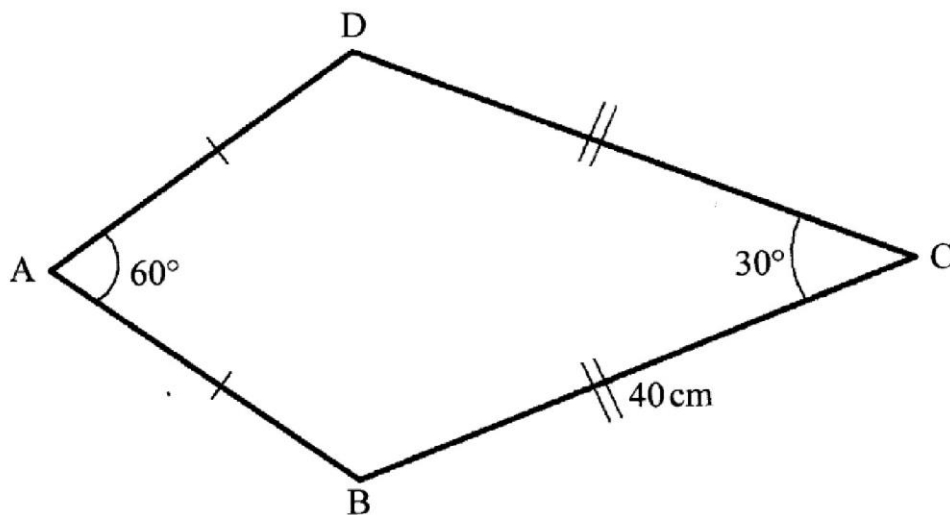

Calculate the area of the quadrilateral ABCD correct to 4 significant figures. (4 marks)

9. The area of a sector of a circle is 36.96 cm^2 . The sector subtends an angle of 135° at the centre of the circle. Find the radius of the circle. (Take $\pi = \frac{22}{7}$). (3 marks)

10. Evaluate the expression $\frac{r^2 + \sqrt[3]{r}}{t - 3\frac{2}{3}}$ given that $t = 5$ and $r = 27$. (2 marks)
11. Two employees Njoka and Okoth contributed $\frac{1}{4}$ and $\frac{1}{6}$ of their salaries respectively to start a project. The contribution amounted to Ksh 16 000. If Njoka contributed $\frac{4}{9}$ and Okoth $\frac{1}{3}$ of their salaries, the contribution would have been Ksh 30 000. Calculate each person's salary. (3 marks)
12. Solve $x - 8 \leq -x \geq 4 - 3x$ and represent the integral values of x on a number line. (4 marks)
13. Figure ABCDEF is a regular hexagon. Line AE and BF intersect at G. (4 marks)

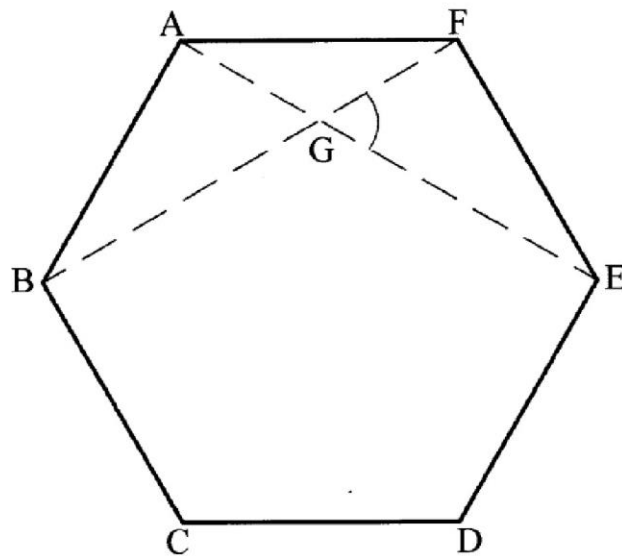

- Find the size of angle FGE. (3 marks)
14. Using a ruler and a pair of compasses only, construct triangle PQR in which $PQ = 8$ cm, $\angle RPQ = 60^\circ$ and $\angle PRQ = 75^\circ$. Measure PR. (4 marks)
15. The marked price of a TV set is Ksh 36 000. A dealer sold the set and allowed a 12% discount on the marked price and still made a 25% profit on the cost price. Find the cost price of the set. (3 marks)

16. Figure $A'B'C'D'$ is the image of $ABCD$ under a rotation. By construction, determine the centre P and the angle of rotation. (3 marks)

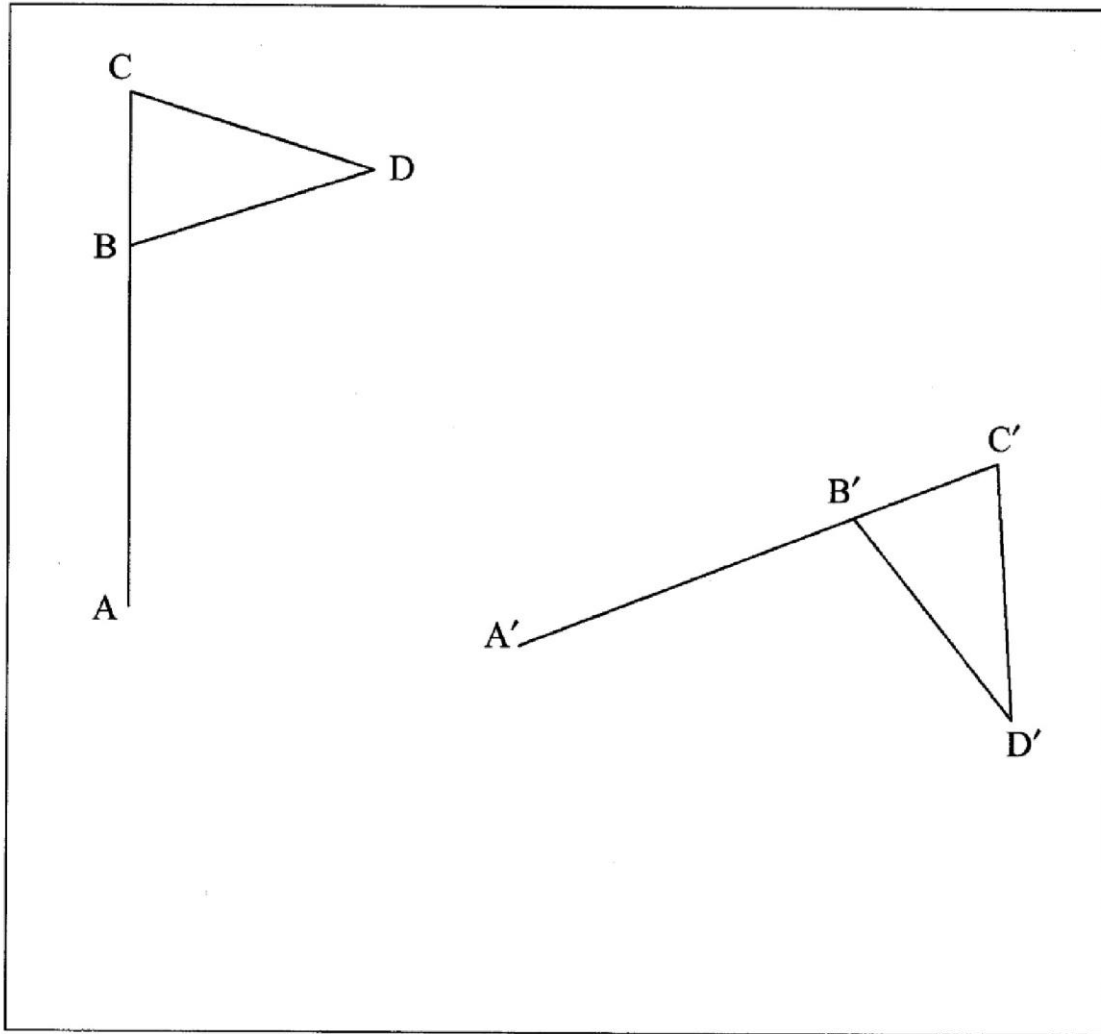

SECTION II (50 marks)

Answer any five questions in this section in the spaces provided.

17. A saleslady earns a monthly salary of Ksh 60 000. She gets a commission of 4% on the value of goods she sells above Ksh 250 000 but less than Ksh 400 000. On goods sold above Ksh 400 000, she gets a commission of 7.5%.
- (a) In a certain month, she sold goods worth Ksh 525 000. Calculate her total earnings that month. (4 marks)
- (b) In another month, she earned a total of Ksh 94 500. Find the value of goods that she sold that month. (6 marks)
18. Lines $y + 2x = 4$ and $3x - y = 1$ intersect at point T.
- (a) Find the equation of line L_1 , which passes through point T and $(3, -2)$. (5 marks)

- (b) A line L_2 passes through $(5,4)$ and is parallel to L_1 . Find the equation of L_2 in the form $y = mx + c$ where m and c are constants. (2 marks)
- (c) Another line L_3 is perpendicular to L_1 at T . Find the equation of L_3 in the form $ax + by = c$ where a , b and c are integers. (3 marks)

19. A car travelled from town A to town B. The car started from rest at A and moved with a constant acceleration for 2 minutes and attained a speed of 1.2 km/minute. It then maintained this speed for a further 10 minutes before decelerating at a constant rate for another four minutes. The car finally came to rest at B.

- (a) On the grid provided, draw a speed-time graph for the car. (4 marks)
- (b) Use the graph to calculate:
- (i) the distance, in metres, the car travelled during its deceleration; (2 marks)
- (ii) the distance, in kilometres, covered by the car in the whole journey; (2 marks)
- (iii) the average speed, in km/h, for the whole journey. (2 marks)

20. The figure below is a square of side x cm. The square is divided into four regions A, B, C and D. Regions A and C are squares. Square C is of side y cm. Regions B and D are rectangles.

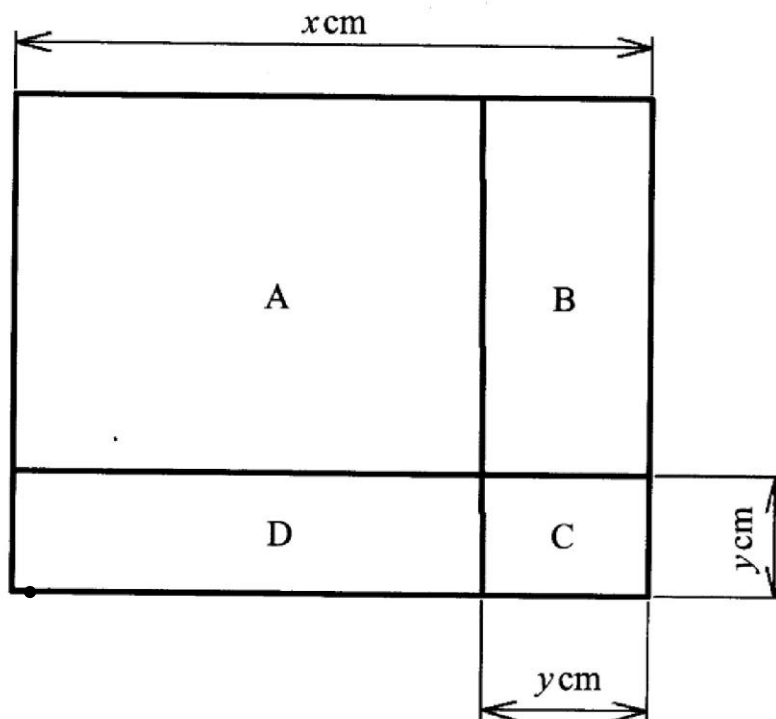

- (a) Find the total area of the following regions in terms of x and y in factorised form:
- (i) A and C; (1 mark)
- (ii) B and D; (2 marks)

(ii) A, B, C and D. (2 marks)

(b) Find the total area of B and D in terms of x given that $y = 2$ cm. (2 marks)

(c) Factorise $25c^2 - 16$. (1 mark)

(d) Evaluate without using mathematical tables:

(i) $5024^2 - 4976^2$ (1 mark)

(ii) $8.96^2 - 1.04^2$ (1 mark)

21. The figure below represents a right pyramid VEFHG mounted on a cuboid ABCDEFGH. Line AB = 6 cm, DA = 8 cm and AF = BG = CH = DE = 3 cm. Line VE = VF = VG = VH = 13 cm.

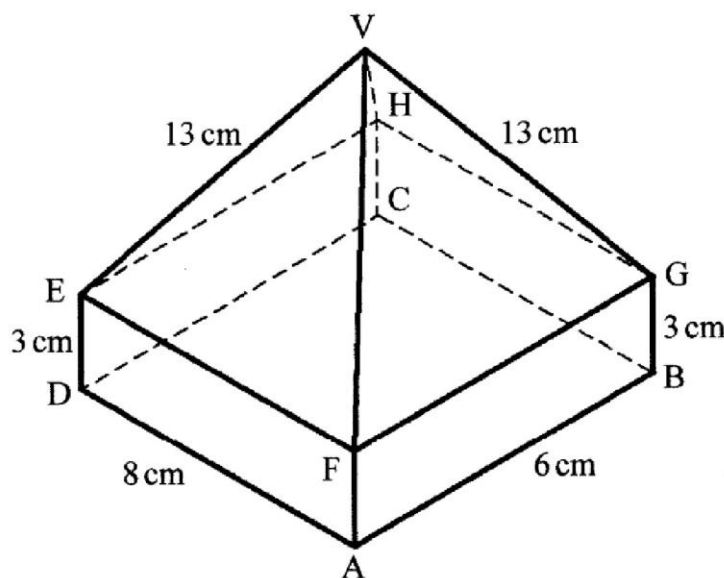

Calculate, correct to 2 decimal places:

(a) the surface area of the rectangular faces; (3 marks)

(b) the surface area of the triangular faces. (5 marks)

(c) the total surface area of the solid. (2 marks)

22. The figure below is a solid which consists of a frustum of a cone, a cylinder and a hemispherical top. The internal radii of the frustum are 42 cm and 21 cm. The vertical height of the original cone was 40 cm and the height of the cylinder is 30 cm.

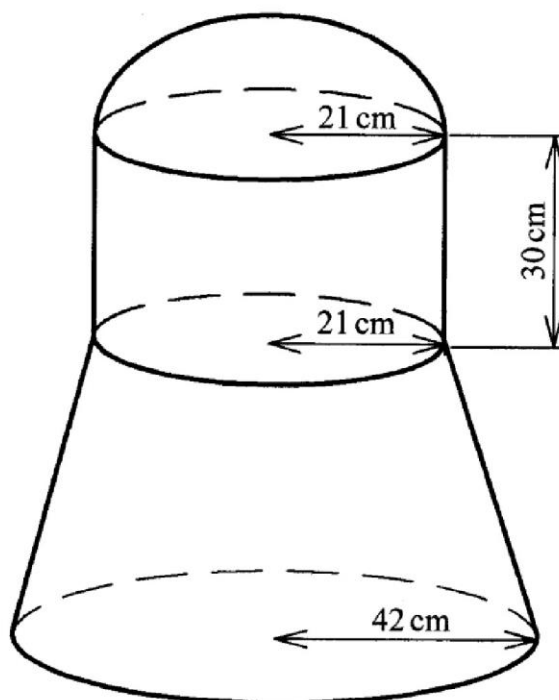

Calculate:

- the volume of the frustum part; (5 marks)
 - the volume of the cylindrical part; (2 marks)
 - the total volume of the solid. (3 marks)
23. Four posts A, B, C and D stand on a level horizontal ground. Post B is 240 m on a bearing of 060° from A, C is 210 m to the south of B and D is 150 m on a bearing of 140° from A.
- Using a scale of 1 cm to represent 30 m, show the relative positions of the posts. (4 marks)
 - Use the scale drawing to:
 - find the distance and the bearing of C from D; (2 marks)
 - determine how far A is to the west of B. (2 marks)
 - The height of post D is 18 m. Calculate, correct to 2 decimal places, the angle of elevation of the top of post D from the foot of post A. (2 marks)

24. The vertices of a triangle are $A(-2, 2)$, $B(2, 2)$ and $C(2, 8)$.
- (a) On the grid provided, draw triangle ABC and its image $A'B'C'$ under a rotation of -90° about $R(1,1)$. (3 marks)
- (b) The vertices of triangle $A''B''C''$ are $A''(-1, -5)$, $B''(-1, -3)$ and $C''(-4, -3)$.
- (i) Draw triangle $A''B''C''$. (1 mark)
- (ii) Describe fully the transformation X that maps $\Delta A'B'C'$ onto $\Delta A''B''C''$. (3 marks)
- (c) Triangle $A'''B'''C'''$ is the image of triangle $A''B''C''$ under a reflection in the line $x = 0$. On the same grid, draw triangle $A'''B'''C'''$. (1 mark)
- (d) State the type of congruence between:
- (i) ΔABC and $\Delta A'B'C'$. (1 mark)
- (ii) $\Delta A''B''C''$ and $\Delta A'''B'''C'''$. (1 mark)