



**MARKING SCHEME**  
**THE ROYAL EXAM SERIES**  
Kenya Certificate of Secondary Education



**GEOGRAPHY 312/1**

1.(a) What is Geography?

(2 Mks)

Geography is the study of the distribution and interrelationships of natural and human phenomena in relation to the earth's surface/It is the study of the earth as a home of human kind.

b) Give **three** proofs that the earth is almost spherical in shape.

(3 Mks)

Circumnavigation of the earth. When one sails or flies along a straight path without changing direction, he or she comes back to the starting point.

The earth's horizon appears spherical when observed from a high point.

Rising and setting of the sun, since people living in the east see the sun earlier than those in the west.

When a ship is approaching the land from the sea, an observer standing on a high cliff first sees the smoke, then the mast and finally the rest of the ship's body.

During the eclipse of the moon, (lunar eclipse), a spherical shadow of the earth is cast on the moon.

All other planets are spherical, hence the Earth being a planet, is not an exception.

Photographs of the earth taken from the space by satellites show that the earth has a spherical shape.

2. (a) Differentiate between weathering and mass wasting.

(2 marks)

Weathering is the breakdown/disintegration/decomposition of rocks at or near surface of the earth in situ by physical/chemical processes while mass wasting is displacement/movement of weathered materials down a slope under the influence of gravity.

(b) State three causes of landslides.

(3 marks)

The gradient of the slope.

Nature of the materials on the slope.

The amount of precipitation.

Occurrence of earth movements such as earthquakes.

Rise in temperature in glaciated highlands.

Clearing of vegetation cover on the steep slopes.

Human activities on steep slopes such as mining and construction.

3. Describe the formation of planet earth according to passing star theory.

(5 marks)

A star with greater gravitational force passed near the sun.

The star pulled large volume of gaseous materials from the sun.

The materials exploded and split into portions which cooled and condensed to form planets. The gravitational force of the sun set planets on their orbits. The smaller gaseous materials formed smaller heavenly bodies such as planetoids natural satellites and comets, all of which revolves around the sun. Planet earth is one of those planets that were formed in this process.

4. The diagram below shows a coastal landform.



(a) Name the features marked **P** and **K**.

(2

Mks)

P – Bay

K – Tombolo

(b) List down **three** types of ocean tides.

(3 Mks)

Perigian tides.

Apogean tides.

Spring tides.

Neap tides.

5 (a) Name the types of earth movements that occur within the earth's crust.(2 Mks)

Horizontal earth movement

Vertical earth movement

(b) Describe the origin of continents according to the theory of continental drift. (3 Mks)

There was initially one super continent/Landmass known as Pangaea.

It was surrounded by large water mass known as panthalassa.

Later Pangaea broke into two continents namely Laurasia (Northern continent) and Gondwanaland (Southern continent).

The two were separated by a narrow ocean called Tethys.

Laurasia split into the current Northern continents: North America, Europe and Asia, while Gondwanaland split to the current Southern continents: Africa, South America, India, Australia, New Zealand and Antarctica.

6. (a) (i) What type of map is **KIJABE** map extract?

(1 marks)

- A topographical map.

(ii) Give the six figure grid reference of the cattle dip near Kenton. (2 marks)

- 279014

(iii) Give the longitudinal extent of the map. (2 marks)

- From  $36^{\circ}30'E$  to  $36^{\circ}45'E$

(b) (i) Calculate the area to the south of the power line. Give your answer in  $\text{km}^2$ . (2 marks)

*Full squares: 16*

*Half squares: 28*

*Total:  $16+14= 30\text{km}^2$  (+-  $0.5\text{km}^2$ )*

(ii) Describe settlement distribution in the area covered by the map. (5 marks)

- *There are no settlement within the Ewaso Kedong valley*
- *There are nucleated settlement in the markets/shopping centres/villages*
- *Some areas with steep slopes /ridges /river valleys have fewer /no settlement*
- *There are fewer settlement within the forest*
- *Kinale/Kinari forest station has dense settlement*
- *There are no settlement within the plantations*
- *There are few settlements to the west of Naivasha-Narok road*
- *The area covered by the map is generally sparsely settled*
- *There are linear settlement along some roads in the area covered by the map*

(c) Explain *three* factors favoring cattle rearing in the area covered by the map. (6 marks)

- *The presence of scrub and scattered trees show that there is natural pasture for cattle*
- *The presence of many rivers/sources of water show that there is adequate water for cattle*
- *The area has high altitude/above 1000m which provide cool conditions suitable for cattle rearing*
- *The many cattle dips for treatment show that there is access to veterinary services*
- *There are large tracts of land with few settlements ensuring extensive areas available for grazing*
- *Availability of transport as shown by roads/railway for movement of cattle/cattle products*

- Dense settlement to provide market for cattle/cattle products

- (d) (i) Draw a square 10cm by 10 cm to represent the area enclosed by Eastings 30 and 40 and northings 90 and 00. (2 marks)

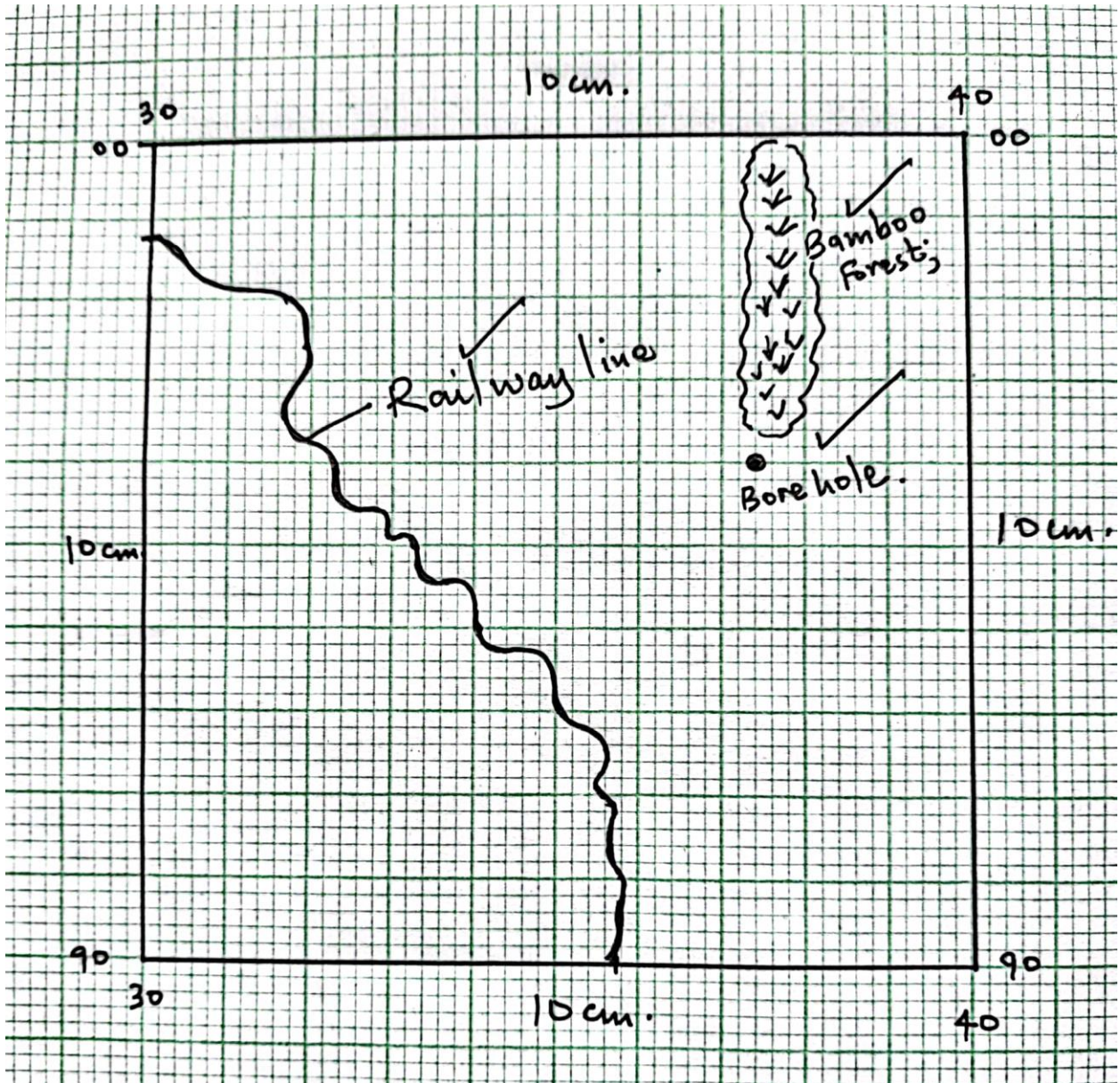

(5 marks)

- A railway line.
- A bamboo forest.
- A borehole.
- New scale.

(Reduction 2 marks, features 3 marks, new scale 2 marks).



7. (a) Name **two** instruments kept in a Stevenson screen. **(2 marks)**

Hygrometer  
 Maximum thermometer  
 Minimum thermometer  
 The six's thermometer

(b) The diagram below shows a weather measuring instrument. Use it to answer the questions below.

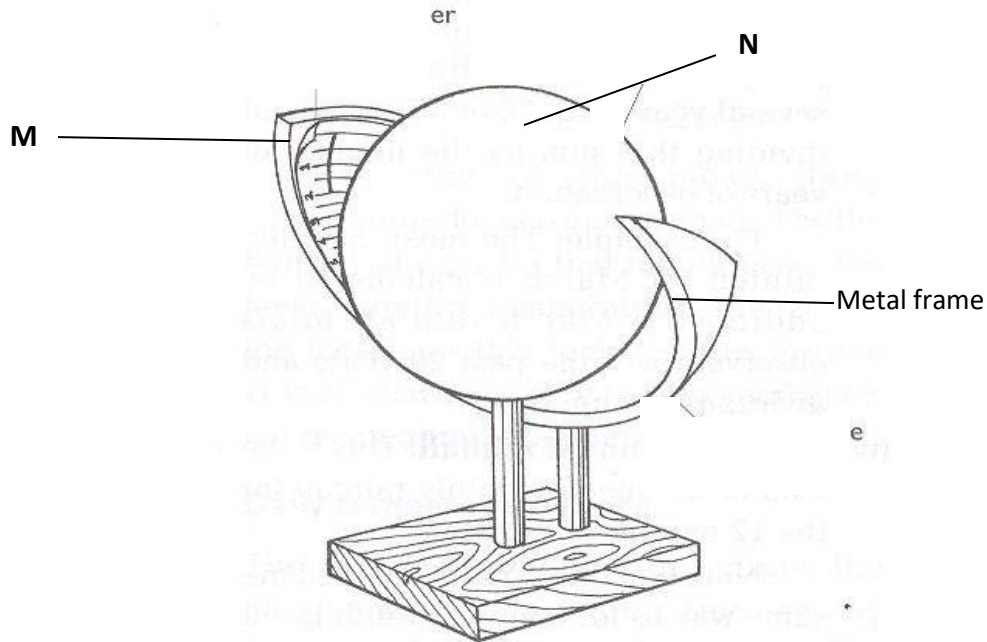

Name the parts marked **M** and **N**. **(2 marks)**

**M** - Sensitized card  
**N** - Cylindrical glass lens

Describe how the instrument works. **(4 marks)**

The glass sphere focusses the sun's rays on a sensitized card which is graduated in hours and minutes.

The heat burns the paper/card as the sun moves across the sky.

The unburnt sections in the card indicates when there was cloud cover.

At the end of the day, the card is removed and the number of hours that the sun shined are obtained by adding the burnt sections on the card.

(c) The table below shows climatic figure for station **Q**. Use it to answer the questions that follow.

Months	<b>J</b>	<b>F</b>	<b>M</b>	<b>A</b>	<b>M</b>	<b>J</b>	<b>J</b>	<b>A</b>	<b>S</b>	<b>O</b>	<b>N</b>	<b>D</b>
Temp in °C	30	31	31	29	27	27	28	29	28	28	27	30
Rainfall in mm	257	246	231	234	207	201	218	227	234	240	235	230

- (i) Calculate the annual range of temperature for station Q. (2 marks)

$$\begin{aligned} &= 31^{\circ}\text{C} - 27^{\circ}\text{C} \\ &= 4^{\circ}\text{C} \end{aligned}$$

- (ii) Outline **four** characteristics of climate in station Q. (4 marks)

The station experiences high temperatures.

Highest temperature is  $31^{\circ}\text{C}$ /the lowest temperature is  $27^{\circ}\text{C}$ .

The annual range of temperature is  $4^{\circ}\text{C}$ /the station has a low range of temperature.

The station experiences high rainfall/2760mm.

The station experiences rainfall throughout the year/there is no dry month.

Lowest rainfall is experienced in May and July when temperature is also lowest.

The station has one rainfall maxima.

- (d) With the aid of a well-labelled diagram, describe the formation of cyclonic rainfall. (6 marks)

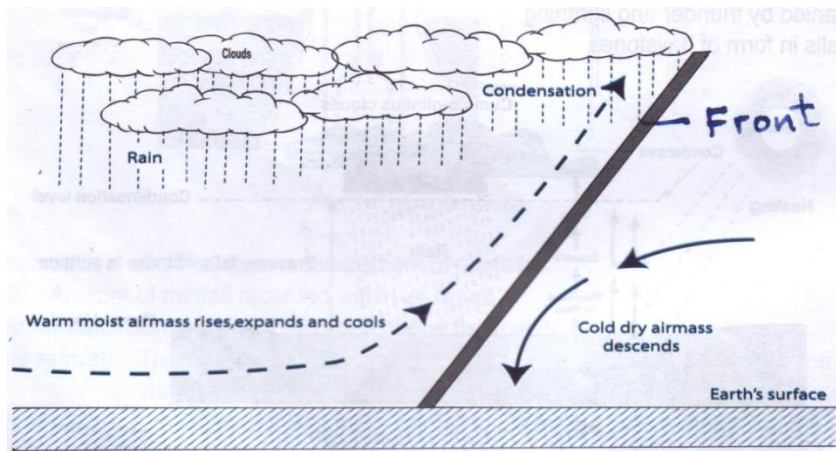

*Text* – 4 marks

*Diagram – 2*

*marks*

*TOTAL* (6 marks)

It occurs along the temperature front.

It is the meeting point of cold, heavy dry polar easterlies and warm, light and moist north/south westerlies.

The meeting of the air masses forms a front.

When the two air masses meet along the front, the warm lighter westerly, winds rises over the cold polar air.

Since it is moist, the air condenses forming clouds.

The clouds become heavy enough, eventually falling as rain through the cold air.

This is cyclonic/frontal rainfall.

- (e) You intend to carry out a field study of a weather station in your school.

- (i) Give **two** methods of recording data that you are likely to use.

Filling in questionnaires  
Labelling of samples  
Note taking  
Taking photographs  
Sketching diagrams  
Tabulation

(ii) State **three** reasons why the recording of data at a school weather station may be inaccurate. **(3 marks)**

Human error.  
Interference with the instruments by animals and people.  
Poor siting of a weather station.  
Extreme weather conditions.  
Natural calamities i.e. landslides.  
Use of defective instruments.

8. (a) Three types of faults:

Normal  
Reverse/ thrust/ low angle over thrust  
Tear / shear / transform  
Continual fault

(b) (i) How compressional forces can lead to the formation of a rift valley  
Diagram

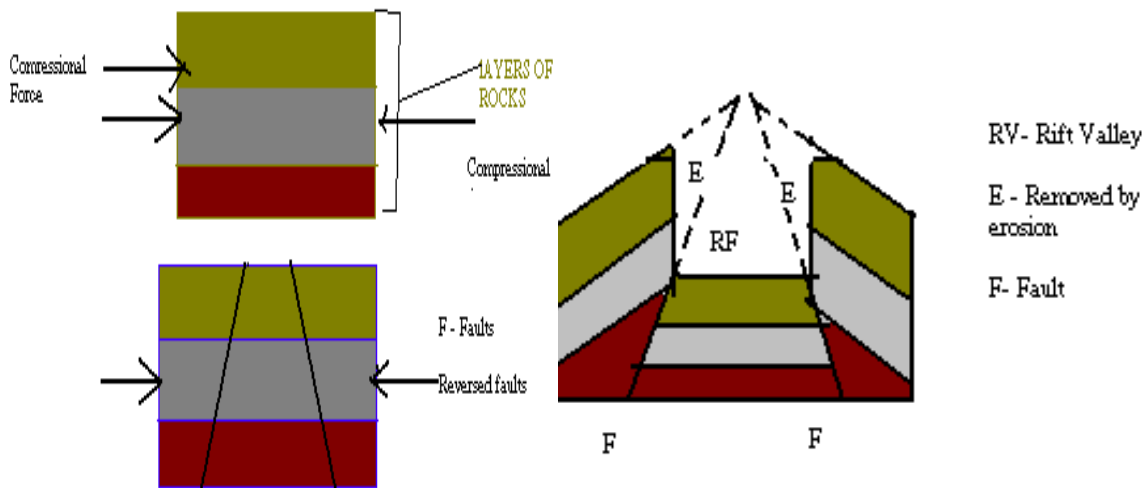

Layers of rocks are subjected to compressional forces  
Two parallel faults develop  
Outer blocks are thrust upwards  
Middle block sinks / remains at a lower level  
The protruding parts are eroded by erosion / collapse  
Diagram = 3 marks      Explanation 4 x 1 = 4  
(ii) Two examples of Horst Mountains in east Africa:  
Pare

Usambara

Ruwenzori

Any 2 x 1 = 2 marks

(iii)

If rift faulting occurs in an enclosed area, a basin may be formed. When rivers flow into the basin, a lake may be formed. This basin may become an area of inland drainage.

Some rivers may end up flowing along fault lines, thus forming a fault-guided drainage pattern.

Uplifting of land which follows faulting may block a river. This may cause it to reverse or change its direction of flow.

When faulting occurs across a river valley, it may cause the river to disappear into the ground through a fault line.

When faulting occurs across a river valley, vertical displacement of land may occur. The river forms a waterfall where it descends the newly formed escarpment.

Faulting may lead to the formation of escarpments with springs forming at the base due to exposure of the water table.

(iv)

tilt block

escarpment / scarp slope

block mountain / horsts

fault steps

(c) Ways in which features resulting from faulting are of economic importance:

Blocks / horst mountains are a source of rivers which provide water for industrial/ agricultural / domestic use / HEP production.

Rift valley formation has led to exposure of minerals such as diatomites/ soda ash which are mined on the rift valley floor.

Mountains formed through faulting attract rain which favour agriculture activities / settlements

Rift valley lakes are important fishing grounds/provide water for irrigation / transportation.

Faulted features provide scenery which promotes tourist industry.

Any 3 x 2 = 4 marks

9.(a) (i) A lake is a mass of water which occupies a basin, depression or a wide hollow on the earth's surface. (1 x 2 = 2mks)

(ii) - Earth movement

Vulcanicity

Erosion

Deposition

Meteorites.

Human activities

By mass movement

(any 3x1 = 3mks)

(iii) - Rainwater

Rivers

Underground water

Melting ice

(any 3x1 = 3mks)



- Lake Victoria was formed as a result of earth movement (down warping) which resulted into formation of a basin like depression.

The level to the west and south was uplifted therefore making the rivers flowing westward to start flowing eastward to back tilting.

The reversal of the drainage caused river water to flood their valleys and fill the depression to form a lake.

- They have surface outlets / rivers through which excess salt deposits are carried away. Some have underground outlets which drains the salts that would have accumulated at the bed.

Some experience low rates of evaporation because they are located in low temperature areas.

The lakes have regular inlets of fresh water which dilutes the salts.

Some of the lakes are located in areas of high rainfall which keeps the water fresh.

(first two correct 2 x 2 = 4mks)

- Some lakes provide water for domestic and industrial use.

Some lakes provide water for irrigation.

Some lakes are sources of minerals e.g. Turkana and L. Magadi.

Lake shores are sources of sand which is used in the construction industry.

Some lakes are used to generate HEP.

Some lakes are used for transport.

Lakes attract tourists.

Some lakes are used for fishing.

(first 3 correct x 1 = 3mks)

(i) NB: Mark any relevant as regards to the lakes e.g.

To find out the importance of lakes.

To find out problems affecting lakes.

To find out the sources of water in the lake.

(2 x 1 = 2mks)

(ii) - Drawing sketches

Note taking

Tape recording

Taking photographs.

(any 2x1 = 2mks)

(iii) - Agriculture - excessive irrigation reduces the volume of the lake.

Chemicals used in the farms pollute the water.

Industrialization: disposal of industrial wastes pollutes the lake water.

Deforestation – may cause the lake to be silted.

Introduction of weeds.

(any first 2x1 = 2mks)

**10. (a) Describe plucking as a process of glacial erosion.**

(4 Mks)

Pressure from the overlying mass of ice causes freeze thaw action.

Melting water fills the cracks/joints in the bed rock.

As water freezes it exerts pressure on the cracks enlarging them.

The enlarged cracks lead to disintegration of the rock.

The rock debris are scoured or pulled off the mother rock by the moving ice.

The disintegrated rocks eventually get embedded within the mass of ice.

As the ice moves, it pulls out or gorges out the embedded rock from the mother rock.

This process is called plucking.

(b) Explain three conditions that lead to glacial deposition. (6 Mks)

Rising temperature lead to melting of ice thereby causing the ice to deposit its load.

Change of gradient to relatively flat surface will reduce the velocity of the glacial movement which will subsequently lead to deposition of glacial materials.

Alternating warm and cold periods lead to seasonal melting of ice which allows materials embedded in the ice to be released and deposited.

Stagnation/accumulation of glaciers leads to pressure at the base of the glacier which in turn leads to melting of ice at the base. The melt water then carries and deposits materials underneath which loosens the heavy materials beneath the mass ice and is subsequently deposited.

Friction at the base and sides of a glacier and a rough surface leads to melting of ice, causing the ice to deposit its load.

(c) The diagram below shows features resulting from glacial deposition on a lowland area.

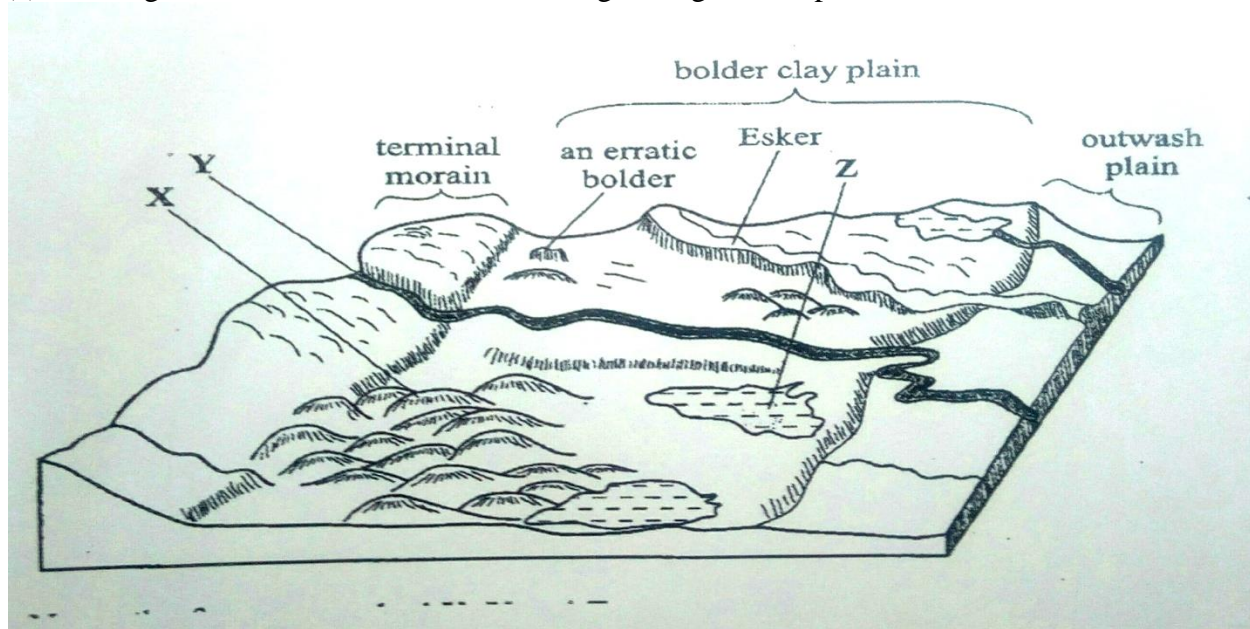

(i) Name the features marked X, Y and Z. (3

Mks)

X - Drumlins

Y – A river/melt water

Z – kettle lake/lake

(ii) Describe how terminal moraine is formed. (4 Mks)

Moving ice carries solid materials

Moving ice stagnates and ice at the snout melts.

Melting ice releases its load

Gradually the load piles into a ridge

Over time the ridge forms a horse shoe shape/block of solid materials called terminal moraine

(d) Explain four positive effects of glaciations in lowland areas. (8 Mks)

Glacial till provides fertile soils which are suitable for arable farming.

Ice sheets in their scouring effect may expose the minerals making them easy to extract.

Out wash plains comprise of sand and gravel which are used as building/construction materials.

Glacial lakes found in lowland areas can be exploited for various economic uses such as fishing and transportation.

Glaciation forms features such as drumlins, eskers which are tourists attraction hence foreign exchange earnings.

Glaciated lowlands are generally flat and ideal for establishment of settlements/development of transportation network.