

AGRICULTURE FORM IV NOTES

27.0.0 Livestock Production V (Poultry) (25 Lessons)

28.0.0 Livestock Production VI (Cattle) (16 Lessons)

29.0.0 Farm Power and Machinery (18 Lessons)

30.0.0 Agricultural Economics III (Production Economics) (20 Lessons)

31.0.0 Agricultural Economics IV (Farm Accounts) (10 Lessons)

32.0.0 Agricultural Economics V (Agricultural Marketing and Organisations) (10 Lessons) 33.0.0

Agroforestry (10 Lessons)

Livestock Production V (Poultry)

Introduction

- Poultry industry in Kenya has developed tremendously due to the use of artificial incubation and brooding and easy availability of hybrid birds, both egg layers and broilers.
- Poultry production has become an easy source of income and food for the rural as well as the urban communities.
- The term poultry includes domestic birds such as turkeys, ducks, geese, pheasants, doves and pigeons.
- Ostrich farming has become a lucrative activity.
- Poultry production starts with incubation of eggs.

Parts of an Egg

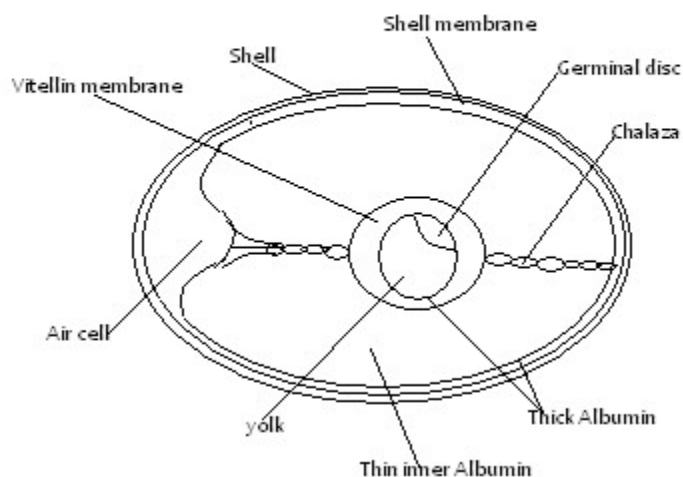

Parts of an Egg

- Shell
 - Forms 10-12% of the whole egg content.
 - Made of calcium and phosphorus.
 - Protects the inner egg contents.
 - Shell membrane
 - Made of inner and outer membranes.
 - Lining of the egg shell.
 - Constitutes 1 % of the total egg content.
 - Albumen (egg white)
 - About 55-60% of the total egg content.
 - It is divided into chalaza, thick and thin albumen.
 - Chalaza holds the egg yolk in position.
 - Albumen serves as food for the chick.
 - Yolk
 - 30-33% of the total egg content.
 - Supply embryo with nutrients.
 - Germinal disc -The embryo which develops into a chick if fertilized.
 - Vitelline membrane - Gives the yolk its round shape.
 - Air sac
 - Keeps the egg fresh by allowing gaseous exchange.
 - Provides oxygen for the embryo
- Egg Candling:

□

- This is the practice of determining the internal qualities of an egg by examining it against a light source.

Procedure

- The egg is placed on a hole made on a cardboard box. This is called a candling box.
- A source of light is placed in the box directly under the egg.
- The observer then looks through the egg against the source of light below. □ Abnormalities on and within the egg can be seen through the translucent shell.

Incubation

- Involves the provision of fertile eggs with the proper condition for embryonic development.

Selection of Eggs for Incubation

- Should be fertile.
- Should be of medium size about 55- 60gms in weight.
- Should have smooth shell.
- Should be oval shaped.
- Should not be cracked.
- Eggs should be clean to ensure that pores are open.
- Should not have abnormalities such as blood spots, meat spots and double yolk.
- Eggs should not be more than 5 days old.
- Eggs should be fresh that is collected within one week.

Internal egg qualities can be determined through the egg candling process.

Methods of Incubation

Natural Incubation

- This involves the use of a broody hen which sits on the eggs to provide them with conditions necessary for hatching.
- Takes 20-21 days.
- The hen is given about 10-15 eggs.

Signs of Broodiness in Poultry

- Tendency to sit on an egg after laying.
- Moulting of the hen.
- Making some noise at the laying nests.
- Feathers are raised.
- It becomes aggressive when disturbed. □ It stops laying.

Preparation and Management of Natural Incubation

- The hen is given "China eggs" to sit on to induce broodiness.
- When broody the hen should be provided with a nesting nest or a saucershaped nest scooped on the ground.
- The nest shall be lined with soft bedding and fertile eggs provided.
- The eggs are set in the evening or night.
- The bird is dusted to control external parasites.
- The hen is allowed t hour outside to feed and exercise everyday.
- Broken eggs should be removed immediately.

- The hen should not be disturbed.

Advantages of Natural Incubation

- It is cheap.
- High hatchability.
- Low risk involved.
- Useful in small scale production.
- Less skill is required. □ Less laborious.

Disadvantages of Natural Incubation

- Egg production is low because the hen will not lay eggs during incubation. □ It is not possible to plan when to incubate.
- If the hen dies the eggs will be destroyed.
- If the hen deserts the eggs or refuses to sit on them the farmer will incur losses. □ Only few chicks can be hatched at a time by one hen.
- Diseases and parasites could easily be transmitted to the chicks.

Artificial Incubation

- This is the use of artificial device known as an incubator for hatching eggs.

Conditions Necessary for Artificial Hatching of Eggs

- Temperature - maintain at 37.5°C-39.4 °C throughout to control the rate of embryonic development of the chick. High or low temperatures are lethal.
- Ventilation - Good air circulation.
- Carbon dioxide: oxygen ratio maintained at 0.03%:21 %. □ Relative humidity - Maintained at 60%.
 - High humidity leads to marshy chicks
 - low humidity the chick may stick to the shell.
- Turning of Eggs –
 - Done 3-4 times a day to facilitate uniform distribution of heat for uniform development of chick.
 - Turn slowly 180 ° clockwise along the axis to avoid breaking the blood vessels.
 - Some incubators have automatic turning mechanism.
- Cleanliness - cleaning and disinfecting the incubator with formaldehyde solution.

Advantages of Artificial Incubation

- It facilitates large scale production of chicks.
- Incubators are always ready when needed.
- Artificial incubation leads to higher egg production because broodiness in the hens is not required, so there is more time for laying eggs.

Disadvantages of Artificial Incubation

- High initial capital in buying an incubator.
- High level of management and attention is required.

-
-
-

- It is not economical for only a small number of eggs.
- High risks involved in turning the eggs.

Brooding and Rearing of Chicks

- Brooding is the rearing of day old chicks upto 8 weeks old for the layer chicks and 2 weeks for the broiler chicks.
For successful brooding the source of the chicks should be considered.

Sources of Chicks

The following factors should be considered:

- The reputation of the supplier (hatchery).
- Time taken by the chicks in transit. □ Proper sexing and breed identification.

Brooding

Natural Brooding

- A hen is allowed to take care of the chicks.
- She provides them with warmth and security.
- She stays with the chicks for 8 weeks and then rejects them.

Advantages □ It is

cheap.

- Less labour is needed.
- Suitable for small scale.

Disadvantages of Natural Brooding

- Not possible to produce large numbers of chicks.
- The hen goes off laying during brooding time.
- Only possible when a broody hen is available. **Artificial Brooding**
- The chicks are raised artificially in a structure known as a brooder until they are 8 weeks old.

Brooder Requirements

- Temperature - should be about 35°C in the 15th week and reduced to 21°C by the 8th week.
- Litter - wood shavings which are capable of absorbing 60% moisture without showing wetness should be used.
- Space confinement - Done by use of hardboards which are about 25cm high and form a circular space. A space of 1m² for 25 chicks is required.

□

- - Feeders and waterers - should be enough for the chicks and evenly distributed in the brooder.
 - Ventilators - windows should be enough to allow proper air circulation but direct draught should be avoided.

Types of Heaters in the Brooder

- Electric heaters - one ordinary bulb 100 watts can raise 30 chicks.
- One infrared bulb 240 watts can raise 100 chicks.
- Kerosene burners - Hurricane lamps can raise 100 chicks.
- Charcoal burners - these are specially made jikos with heat deflectors.

Brooder Management

Preparation Before Chicks Arrive

Start 2-3 days before arrival.

The brooder house should be cleaned to remove old litter and then disinfected. New litters 5-10cm high should be put in and covered with absorbent materials/news papers.

Equipment should be cleaned, disinfected and tested to make sure that they are working.

- The brooder is lit about 6 hours before the chicks arrive.
- Feed and water should be placed into shallow containers.
- Brooder space should be confined with a hard board to prevent chicks straying far from the source of heat.

Management After Arrival of the Chicks

- Chicks are placed in the brooder during the day to familiarize with the brooder.
- If chicks arrive stressed and weak they should be given glucose solution in the waterers.
- In case the heat source is charcoal burners they should be covered with wire mesh.
- Feed chicks with chick mash which is later mixed with growers mash as the chicks grow.
- Clean water should be provided and changed regularly.
- Constant attention should be given to the chicks for the first 2 weeks.
- Any vices should be checked and controlled.
- Any dead chicks should be removed as soon as seen.
- Ventilation should be used to control the temperature and humidity in the brooder.
- Constant disinfection is required at the entrance to avoid diseases.
- Brooder space should be increased as the chicks grow.
- Debeaking should be done at 10 days old.
- Vaccination against diseases such as Gumboro after 2 weeks, New Castle at 3-4 weeks and fowl typhoid at 7 weeks.
- Dusting to control external parasites.

□

□

□

□

- Growers' mash should be introduced gradually at 7 weeks old.
- Chicks are removed from the brooder when they are 8 weeks old.
- On average the chick uses about 1.5kg - 2.2kg of chick mash by the time it is 8 weeks old.

Temperature Control in the Brooder

If the brooder temperatures are low the following should be done:

- Brooder space is reduced.
- Heaters are increased. □ Ventilators are closed.

If the brooder temperatures are too high the following should be done:

- Brooder space is increased.
- Heaters should be reduced.
- Ventilators should be opened.
- Management of the Growers
- The growers are birds at the age of 9 weeks to the point of lay that is at 18 weeks.
- Growers should be fed on growers' mash.

By this time the growers should be occupying the main poultry house.

□

-
-
-

Sick birds should be isolated and treated.

A foot bath for constant disinfection should be placed at the entrance.

- Each bird is fed 115 gms per day of growers' mash. Greens and soluble grit should also be provided.
- Clean water should be provided all the time (ad libitum).
- Drenching against internal parasites should be done by adding a dewormer into the water.
- Vermins should be controlled.
- Litter should be kept dry by turning.
- Vaccination should be done as required.
- Layer pullets require dimly lit house. **Management of the Layers**
- Layers' mash should be introduced at 18 weeks and increased gradually.
- The birds start laying at 18-21 weeks.
- The birds should be vaccinated against New Castle and fowl typhoid.
- Enough floor space roosts, feeders and waterers should be provided.
- Each hen should be given 120gms per day of layers' mash.
- Clean water should be provided ad libitum.
- Eggs should be collected twice a day at noon and in the evening.
- Green leaves should be provided to keep the birds busy thus preventing cannibalism and improve the yellow colour of the yolk.
- Grains should be given in addition to the layers' mash at the rate of 65gms per bird per day.
- Soluble grit or oyster shells should be provided at all times for efficient digestion and strong shelled eggs.
- Layers should be fed according to their body weight and the rate of egg production for example a 70kg bag should feed 100 layers for 4-5 days.
- Enough laying nests should be provided at least 1 per 5 layers.
- The laying boxes should be dimly lit to reduce egg eating.
- Debeaking should be done when necessary.
- Broken eggs and dead birds should be disposed off properly.
- The non-layers and cannibals should be culled.

Management of Broilers

- Broilers are table birds kept for meat production.
- They have high growth rates or high feed conversion ratio.
- The objective is to produce a kilogram of quality poultry meat from less than two kg of broiler feed.
- The broiler chick requires special broiler feed from day old to 4 weeks of age.
- Broiler starters' mash or crumbs should be fed.

□

-
-
- - This contains coccidiostat, high level of protein, vitamins and trace elements for early growth.
 - From 4 weeks to 8 weeks they are given broiler follow-on mash or pellets.
 - This feed contains high level of metabolisable energy to ensure a good cover of subcutaneous fat in the finished broiler.
 - From 8 weeks until slaughter finisher pellets should be given to increase the size. Adequate clean water should be provided at all times (ad libitum). High level of hygiene should be maintained to reduce mortality rate. Birds should be dusted with appropriate pesticides to control external parasites.
 - Deworming should be done routinely. Vaccination against common diseases should be done.
 - Dead birds should be disposed off properly.
 - Broilers should be kept under deep litter system, the house should be well ventilated and well lit.

Poultry Rearing Systems

- extensive,
- semi intensive □ intensive systems.

The Extensive Systems

Free Range

- Birds are set free throughout the day to fend for themselves.
- Birds are confined in night shelters for the night.
- There is no supplementation.

Advantages

- Birds eat insects and green leaves therefore less feed is required.
- Cheap method.
- Cannibalism and egg eating are reduced since the birds are not crowded.
- Manure is evenly spread in the runs.
- Low labour requirement.
- Birds get plenty of exercises thus helping to keep in good health. □ No need to provide grit as birds pick it from the soil.

Disadvantages

- More land is required if a farmer wants to rear many birds.
- Birds can be stolen or eaten by predators.
- Eggs get lost in the vegetation or stolen. □ Eggs get dirty.
- Difficult to determine layers from non-layers.
- Birds get easily infected with diseases and parasites of the area.
- Breeding programme is not easy to follow.

- Birds can destroy crops where perimeter fencing is not constructed.
- Low productivity per unit area.

Semi-Intensive

Fold System

- Birds are confined in small portable structures called folds. □ A fold measures 3.5m long, 1.5m wide and 1.5m height.
- 1/3 of the fold is roofed while the rest is enclosed with wire mesh.
- Birds get plenty of sunlight.
- Birds get fresh grass as the fold is moved to new grounds.

Advantages

- Manure is evenly spread in the field.
- Less feed is used because birds eat grass.
- Reduces build up of parasites and diseases since the fold is moved often.
- Birds are protected from predators.

Disadvantages

- Few birds are kept per fold.
- It is laborious since the folds are moved from one place to the other.
- Individual egg production record is difficult to keep. □ The fold does not last long because of
- high frequency of handling.
- The return per unit area of land is low.

Intensive System

Deep Litter System

- Birds are confined in a house throughout their life.
- The floor of the house is made up of litter which accumulates over time.
- Enough feeders, waterers and laying boxes are provided depending on the number of birds and space available.
- Movable roosts and perches made of timber frames should be provided in the house.
- Stress and vices should be watched closely and controlled.
- Eggs should be collected as frequently as possible to prevent dirt and egg eating. □ The house should be dimly lit.
- The floor space requirement should be 1m² per 2-3 birds.

Advantages

- High stocking rate per unit area of land.
- Low labour requirement.
- Fast accumulation of manure.
- There is control of feeding, egg production and movement of birds.
- Safety of the birds is guaranteed from predators. □ No loss of eggs.
- Useful method when rearing breeding stock.

-
-
-
- Regular cleaning of the house is not necessary since the litter absorbs the droppings.
 - Easy collection of eggs.

Disadvantages

- High incidence of cannibalism like egg eating, feather plucking and toe pecking.
- Pests and disease causing organisms accumulate in the litter.
- Individual records of the birds are not possible. □ May be difficult to find litter.
- Eggs become dirty if laid on the floor.
- Feeders and waterers may be contaminated by the litter.
- The system encourages broodiness in hens.
- High infestation of diseases if the management is below standard.
- If there is a disease outbreak, it can spread very quickly throughout the house due to the communal housing.
- High cost of building deep litter house.

Battery Cage System

- Birds are confined in cages which are placed in the poultry house. □ The cages are made of wire mesh □ Each cage contains 1-3 birds.
- Water and feed troughs together with eggs trays are fitted along the front side of the cages.
- The floor of the cages should be slanting to allow the eggs to roll out of the cages.
- Droppings from the cages fall from behind for easy cleaning.

Advantages

- Records are easily kept therefore culling is easy.
- Birds do not become broody.
- More eggs are collected due to restricted movement of the hens and complete control of egg eating.
- Tender meat is obtained from the culls because the muscles have not been toughened much.
- Handling is easier than in the other systems and individual attention to hens is given. □ Stocking rate is very high.
- Vices are greatly reduced.
- Eggs are clean because hens do not step on them.
- The system can easily be mechanised.
- Birds do not contaminate the food and water.
- Sick birds can be detected easily and isolated for treatment.
- Wire floors prevent re-infestation of parasitic worms and coccidiosis.
- No bullying during feeding. □ Low labour requirement.

Disadvantages

- Initial costs for cages, equipment and house are excessively high.
- Requires high level of management.
- Higher maintenance costs where automation is used.
- Birds may get fatigue due to lack of exercises thus lowering productivity.
- In case of disease outbreak, spreading is very fast.
- Birds develop bruises on combs, breasts and toes as they stick their necks out-to feed and walk in the cages.
- Not useful when rearing breeding stock and the rearing of broilers.
- Cannot be used for brooding young chicks.

Stress and Vices in Chicken

- Stress is a condition imposed on the birds making them disturbed and uncomfortable.
- Stress reduces production and brings about poor performance.
- Vices are habits developed by animals.
- These affect production and health of the birds.

- Usually they are bad habits.

Cause of Stress in Poultry

- Sudden changes in routine management.
- Presence of strangers in the poultry house.
- Presence of animals and vermins.
- Too much noise.
- Constant and poor handling.
- Sudden weather changes.
- Disturbance of the pecking order. □ Overcrowding □ Poor hygiene.
- Disease and pest attack.

Lack of food and water. Control of Stress

- Poultry house should be kept quiet and constructed away from noise.
- Poultry house should be insulated to maintain constant temperatures.
- Parasites and diseases should be controlled.
- Change in routine management should be gradual.
- Enough feed and water should be provided.

Vices

- Feather pecking.
- Cannibalism (toe and vent pecking).
- Egg eating.

Pecking and Cannibalism

- Situation where birds peck at each other resulting in death or injury.

Effects:

- Feather and body growth rate IS reduced.
- Loss of birds due to death may result from cannibalism.
- Culling rate is increased (economic loss).
- The appearance of the carcass is spoiled thereby reducing its market value.

Causes of Cannibalism

- Overcrowding in the house.
- High temperatures in the poultry house making the birds uncomfortable.
- Too bright light.
- External parasite infestation.
- Inadequate and incorrect feeding.
- Idleness of the birds.
- Greediness of the birds.
- Disturbances of the pecking order.
- Prolapses of the rectum which occurs once in a while.
- Bright light in the lying boxes.

Preventive Measures

- Ample spacing should be provided on the floor, feeders, waterers and laying boxes.
- Overheating should be avoided during brooding.

- The house should be dimly lit for the layers.
- Laying nests should be darkened and above the ground.
- Dusting should be done to control external parasites.
- Provide enough balanced ration.
- Birds should be kept busy.
- New/strange birds should not be allowed in the house.

Egg Eating

A vice influenced by the following:

- Presence of broken or soft shelled eggs.
- Idleness of the birds.
- Inadequate laying nests.
- Mineral deficiencies.
- Bright light in the laying nests.
- Greediness of the birds.

Preventive Measures

- Eggs should be collected regularly.
- Laying boxes raised above the ground.
- Laying boxes should be darkened.
- Birds should be given balanced ration.
- Debeaking should be done as need be. □ Birds should be kept busy with greens.
- Birds should be kept according to age groups.
- Injured birds should be isolated and treated.

Marketing of Poultry Products

- Poultry products include eggs and meat.

Marketing of Eggs

- Eggs are delicate and perishable foods and have the highest value when fresh.

The factors considered when sorting out and grading eggs for the market include:

- Size/weight of the egg - large eggs fetch high prices than small ones. The average weight should be about 57gms.
- Shape of the egg - The normal egg shape is oval, with a broad end and a narrow end.
- Cleanliness - Consumers prefer clean eggs.
- Colour of the shell - Brown eggs are popular with the consumers.
- Candling qualities - candling is done to determine freshness of the eggs and presence of any other egg abnormalities.
- Shell texture - should be smooth and without cracks.

Poultry Meat

- Broilers are slaughtered at the age of 1-2.5 months old with a live weight of 1.5-2kgs.
- The birds are killed and dressed in a clean way before being wrapped in clean bags ready for sale.
- The meat is sold in hotels and restaurants.

- Whole birds can be sold live in local markets.

Livestock Production VI (Cattle)

Introduction

- Cattle production is a widely distributed enterprise in Kenya.
- Most farming communities choose between the exotic and the ' local breeds or their crosses depending on the environmental conditions.
- Whereas the backbone of beef industry in Kenya is made up of the indigenous animals and their crosses, and based in the somewhat drier areas, the-dairy industry is mainly based on the exotic breeds and their crosses and common in the wetter regions of Kenya.
- Whatever production undertaken, the returns depend mostly on the management levels provided to these animals.
- A productive herd starts with good management of the young stock.

Raising of Young Stock.

- The young one of cattle is known as a calf.

Feeding Dairy Calves

- Newborn calves should be given colostrums within the first 3-5 days of their life.
- Colostrum is important for the following reasons:
 - It is highly digestible.
 - It contains antibiotics.
 - It is highly nutritious.
 - It serves as a laxative. □ Calves can be fed using natural method (direct suckling) or artificially/bucket feeding. Natural Method

- In this method, calves suckle the mother directly.

Advantages

- The calf takes milk at body temperature.
- The milk is free from contaminants.
- Less problems of scouring.

Disadvantages

- Underfeeding of the calf may result.
- Cows may not let down milk in case the calf dies.

- Difficult to keep accurate production records.

Artificial/Bucket Feeding

- The calf is trained to feed from the bucket immediately after birth.

The calf is trained as follows:

- Well measured milk is put in a clean bucket.
- Index finger is inserted into the mouth of the calf.
- The head of the calf is lowered slowly into the bucket until the calf starts to drink the milk.
- The finger is withdrawn slowly as the calf continues to drink from the bucket.
- The procedure is repeated until the calf gets used to the process. **Advantages**
- Easy to keep accurate production record/milk yields of the cow.
- Possible to regulate the amount of milk given to the calf
- The cow does not need the presence of the calf in order to let down milk
- Easy to maintain high hygiene standards.

Disadvantages

- Laborious
- Calf may be given cold milk
- Equipment used and the stockman may be dirty leading to scours

Preparation of artificial colostrums

Ingredients used

- A fresh egg whipped in 0.86 litres of warm water
- Litre of warm water
- One teaspoonful of cod liver oil
- One tablespoonful of castor oil
- Note; colostrums is fed to the calves three times a day for the first 4 days of life and thereafter twice a day.

Weaning of calves

Early weaning

- Calf is fed on whole milk up to the tenth week then it is weaned
- Calf is given milk equal to 10% of its body weight up to the 8th week
- After 8th week, milk is reduced gradually by 1 kg until weaning □ Calf is given early weaning concentrates and soft forage

Early Weaning Guide

Age in weeks	Whole milk(kg/day)	Concentrates(kg/day)

1	Colostrums ad libitum	-
2-3	5	-
4-5	6	0.25kg/day
6-7	6	0.5kg/day
8-9	5	0.75kg/day
10-11	4	1.00kg/day
12-3	-	1.50kg/day
14-15	-	2.00kg/day
16	-	2.00kg/day

Late weaning

- Calf is fed on whole milk up to the 3rd week, when milk is replaced gradually with skim milk.
- At the age of 3 weeks the calf is introduced to calf pellets or pencils and green fodder. □ The calf is given plenty of clean water.
- The calf continues to be given additional skim milk up to the age of 14 weeks when maximum amount of milk is given.
- Skim milk is reduced from 14 weeks to 16 weeks when weaning is done.

Late weaning guide

Age in weeks	Whole milk (kg/day)	Concentrates (kg/day)	Skim milk (kg/day)
1	Colostrums ad libitum	-	-
2	3.5	-	-
3	4	-	-
4	4.5	0.25kg/day	1
5	4.0	0.5kg/day	3
6	3.0	0.75kg/day	5
7	-	1.00kg/day	7
8-14	-	2.00kg/day	8
15	-	2.00kg/day	4
16	-	2.00kg/day	4

Rearing of replacement stock

- The replacement stock includes young heifers and bulls which have been selected for breeding to replace the old stock.

Management Practice

- Parasite control-Spraying against external parasites and deworming against internal parasites.
- Disease control-Calves are vaccinated routinely against diseases such as;
 - Blackquater-at 4 months old.
 - Anthrax and Blackquater at 6 months old
 - Brucellosis - 3-8 months old (heifers).
- Castration - for male calves not selected for breeding.
- Identification - Suitable methods are used. It allows proper record keeping.
- Removal of Extra Teats ;
 - These teats are known as supernumerary teats which make milking of the animal difficult.
 - They are clipped off with teat clippers.
- Dehorning/Disbudding - The removal of horn buds using suitable methods.

Calf Housing

Requirement of a Calf Pen;

- Should be clean and easy to clean.
- Be warm and dry.
- Have adequate space to allow exercise and feeding.
- Should be properly lit and allow sunlight for Vitamin D.
- Have proper drainage to avoid dampness.
- Draught free to prevent chilling.
- Be well ventilated to allow fresh air.

Types of Pens

These can be;

- permanent
- mobile/movable.

Permanent Pens

- Have a solid floor raised above the ground. □ The floor should be slanted for drainage.
- Constructed near the milking parlour. **Mobile/Movable Pens**
- Have an open floor to allow grass into the pen.
- Easily moved from one place to another to avoid soiling.
- Kept outdoors in the pastures to allow the calf to nibble on pastures. **Single Housing**
- Calves should be housed singly up to the age of 3 weeks, when they are put in group pens.
- This is to avoid them licking each other and swallowing hairs which form indigestible balls.

Milk and Milking

- Milk is the white lacteal substance secreted by the mammary glands of the female mammals.

Composition of Milk

- Protein - Casein and whey.
- Fat - Butter fat.
- Carbohydrates - Lactose
- Minerals - mainly calcium and phosphorus.
- Water

Factors Affecting Milk Composition

- Age of the animal.
- Conditions of the animal.
- Stage of lactation and pregnancy.
- Completeness of milking.
- Type of breed.
- Season of the year.
- Type of food eaten.
- Physiological conditions such as diseases.

Milk Secretion and Milk Let-down

- Milk is secreted by the mammary glands which is an accessory gland of the reproductive system.
- The mammary gland of a cow is known as an udder.

Structure of the udder

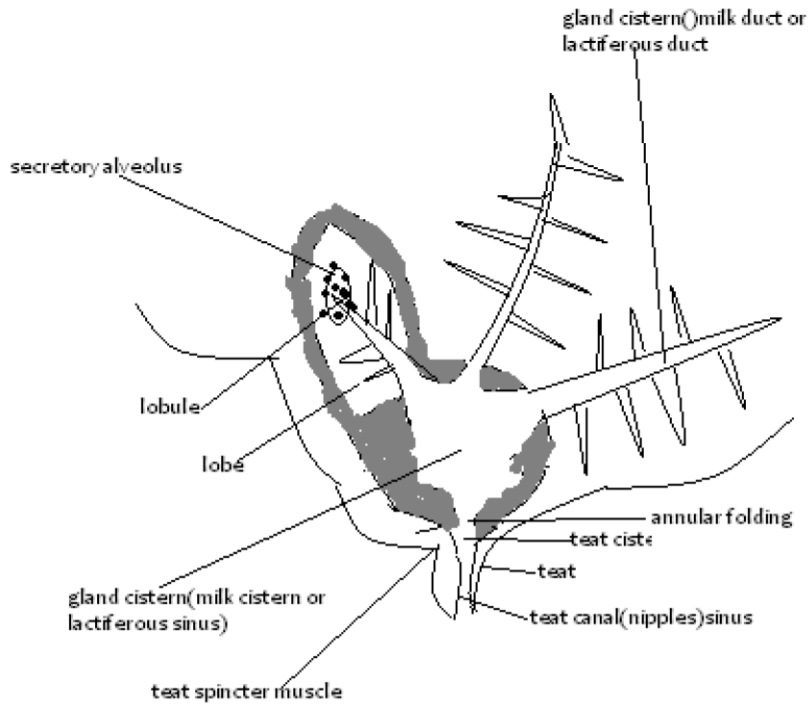

Structure of the Udder

The udder is composed of the following parts:

- Alveolus cells - synthesize and secrete milk.
- Lobule - a group of alveolus cells.
- Lobe - Several lobules grouped together and drained by lactiferous ducts.
- Gland cistern - space where milk collects from the lobes.
- Teat cistern - A space where milk collects before emission. □ Teat -An organ which drains each quarter of the udder.

Milk Secretion

- The process of milk secretion is known as lactogenesis. □ The digested food is taken to the udder via blood vessels.
- In the udder the nutrients are carried into the alveoli cells where metabolic reactions take place to build up these nutrients into milk.
- A hormone prolactine is secreted by pituitary gland which brings about lactogenesis.
- The milk secreted is then stored in the upper parts of the udder waiting to be released.

Milk Let -Down

- The process of milk let-down occurs naturally when the animal is stimulated.
- Milk secreted moves from alveolar region through the ducts to the gland cistern.
- Oxytocin, a hormone secreted by the pituitary gland causes the contraction of the udder muscles forcing the milk down the teats.
- Oxytocin hormone lasts 7 -10 minutes in the blood stream hence fast milking is important to withdraw the milk.
- Milk is withdrawn from the teats by gently squeezing them.

Factors Influencing Milk Let-Down

- Presence of the calf.
- Presence of the milkman/milker.
- Rattling of the milk equipment.
- Site of the food/feeding the animal.
- Massaging or washing the udder. □ Sight of the milk parlour.

Factors Inhibiting Milk Let-Down

- Beating the animal/inflicting pain to the animal.
- Presence of strangers and animals for example dogs.
- Poor milking techniques.
- Absence of the calf (in case the cow is used to it).

Clean Milk Production

The following factors are essential for clean milk production:

- A healthy lactating cow.
- A healthy and clean milker.
- Clean and properly constructed milking parlour.
- Clean and disinfected milking equipment.
- Proper handling of the milk after milking.

Milking Procedure

- The animals are brought near the milking parlour 15-20 minutes before milking to get into the mood of being milked.
- Milking materials such as equipment, feeds, ropes, stools and salve are collected and placed near the milking parlour.
- The animals are allowed into the milking stall one by one as the milking proceeds as follows:
 - The animal is restrained in the stall.
 - Feed is weighed and placed into the feed trough.
 - The udder is thoroughly washed, disinfected and dried with a clean cloth.
 - A strip cup is used to test for mastitis on each quarter.
 - Milking proceeds by squeezing the teats with the full hand. If machine milking the teat cups are placed on the teats.

- For hand milking start with the hindquarters and finish with the forequarters.
- Fast milking should take about 8 minutes then end with stripping the udder.
- The milk is weighed and recorded.
- The animal is then released.

Dry Cow Therapy

- This is the infusion of antibiotics into the teat canal of a cow that is preparing for drying off.
- It prevents bacterial infection which leads to mastitis.

Milk Products

- Pasteurized milk - milk that is heated and cooled immediately.
 - Ultra Heat Treated (UHT) - milk heated to a temperature of 130-135C, packed and then cooled.
 - Butter - Milk butter fat separated by a process known as churning. □ Cream -A layer of is: that collects at the top of the milk when left to stand.
 - Cheese - Milk proteins which have been compressed.
 - Ghee - Milk fat made from heating cream or butter.
 - Skim milk - Milk without butter fat.
- ### Marketing of Milk
- The Kenya Dairy Board regulates the production and sale of milk and milk products through various Dairy Co-operative Societies.
 - Processors and distributors of milk and milk products include; ○ KCC, ○ Brookside Dairies, ○ Tuzo, ○ Delamere Dairies ○ Limuru Dairies.

Marketing of Beef

Done by the following:

- Individual fanners through the local slaughter house.
- Livestock marketing division.
- Kenya Meat Commission. □ Farmer's Choice.

Farm Power and Machinery

Introduction

- Farm power is any form of energy used in the farm to do work.

Sources of Farm Power

Human Power

- Performs light tasks.
- Quality of work produced is variable.
- Takes a long time to complete a task.

Animal Power

□

Done by draught animals such as camels, donkeys, horses and elephants.

- Used in land preparation and transportation.

Disadvantages

- Slow.
- Animals are liable to sickness and get tired. □ Need enough food.

Wind Power

- To pump water from boreholes.
- To winnow crops such as beans, finger millet and rice. □ Generate electricity.

Disadvantages

- Not easy to control and may not be available when needed.

Water Power □

Irrigation.

- Grinding mills (to grind maize grains). Disadvantages
- Difficult to use in the farm because it is not easy to control. Biomass

This includes: □ wood or charcoal □ biogas power.

Charcoal/Wood Fuel Energy

Uses

- Provides heat for boiling water and cooking.
- Dehydrating of some crops.
- Curing of tobacco.

Disadvantages

- Exhaustible.
- It cannot be used directly in some farm operations.
- Large quantities are required.
- They are bulky hence difficult to transport.

Biogas

Uses

- Provides heat and light for cooking, boiling water and lighting.

□
□

- Produces electricity.

Disadvantages

Only possible where there are animals under zero grazing unit. It is labour-consuming.

- Large quantities of dung are required.
- Cannot be used directly in some farm operations. Fossil Fuels

These include:

- coal, □ petroleum oils □ natural gas.

Uses

- Petrol or diesel is burned in internal combustion engines to produce power.
- Kerosene is the main source of power to light rural homes.
- Natural gas is used for cooking, heating and lighting. Electrical Power

It includes:

- hydro-electrical power (HEP),
- geothermal,
- nuclear
- power stored in batteries.
- Nuclear energy is a potential source of power which has not yet been used in the farms.

Uses of Electrical Power

- Runs stationary machines such as milling machines, grinding mills, cooling machines and water pumps.
- Supplies heat and light for operations of brooders.

Disadvantages

- Cannot be used directly in some farm operations.
- Lack of electricity in the rural areas.
- Power failures can lead to high losses.
- It is costly to install and maintain.

Solar Energy

Energy obtained from the sun.

-
-

□

Uses

- Provides heat and light.
- Used by all the plants in photosynthesis.
- Dehydrating crops such as vegetables, maize grains, beans and hay.
- Boils water which drives turbines to produce power for minor uses.

Disadvantage

Low concentration of energy on cloudy days.
Expensive In collecting and concentrating equipment.
Cannot be used directly in some farm operations.

- Requires skilled labour to install and maintain.

Tractor

- The tractor has an internal combustion engine which burns petrol or diesel to produce power.
- This power is then passed to the gear box from where it is transmitted in various ways. □ The common tractor engine is a four stroke cycle engine.

The four strokes are:

- Induction stroke.
- Compression stroke.
- Power stroke.
- Exhaust stroke.

Induction Stroke

- Piston moves down.
- Inlet valve opens.
- Fuel and air get into the cylinder.

Compression Stroke

- Inlet valve is closed.
- Piston moves up the cylinder.
- Fuel-air mixture is compressed.

Power Stroke

- A spark is produced at spark plug, igniting the fuel-air mixture. □ The increased pressure forces the piston down the cylinder.

Exhaust Stroke –

-
-

- Exhaust valve opens.
- Piston moves up the cylinder.
- Burned fuel-air mixture expelled.

Advantages of the Four Stroke Engines

- Produce high power which can do heavy farm work.
- Have efficient fuel and oil utilization.
- Perform a wide range of farm operations.
- Are effectively cooled with water thus allowing the production of large engine size. □ Exhaust gasses are effectively expelled from the cylinders.

Disadvantages

- Are expensive to buy and maintain
- Their use is limited in some areas;
Tractor can only be used on flat or gently sloping areas
Require skilled personnel and support services

□
□

-
-
-

The Two Stroke Engines

- Found in small machines such as mowers, motor bikes, and water pumps which do light jobs in the farm.
- All the cycles are completed in two strokes of the piston.

These strokes are;

Induction and compression stroke

- The piston is at the bottom
- Piston moves up uncovering the inlet port
- Fuel-air mixture is drawn in
- Ignition occurs when the piston reaches the top
- Piston is forced downward compressing the mixture in the crank. Power and exhaust stroke
- The piston is at the top
- Ignited gases produce pressure which force the piston downwards
- The piston covers the inlet port and traps fresh fuel-air mixture in the crank case
- Piston moves further down to uncover the exhaust port
- Fuel-air mixture transferred from the crankcase to the combustion chamber.

What Advantages of two stroke engine?

- Cheap to buy and easy to maintain
- Economical in fuel consumption
- Can be used in a wide range of farmland, including hilly areas
- Can do small tasks in the farm which would be un-economical to do using the four stroke engine.

What disadvantages of two stroke engine?

- They produce less power hence cannot be used for heavy duties.
- They are inefficient in burning fuel to produce power.
- They are air cooled thus limiting the size of the engine.

Systems of a Tractor

The modern tractor has the following systems:

The fuel system.
Electrical system
Ignition system

- Cooling system
- Power transmission system.

The Fuel System

Supplies fuel to the engine.

Categorized into two types depending on the fuel used.

These are:

- The petrol fuel system.
- The diesel fuel system

The Petrol Fuel System

Consists of:

- Fuel tank - storage of fuel.
- Fuel filter - removes foreign particles from the fuel.
- Carburettor –
 - atomises fuel into spray.
 - introduces fuel-air mixture into the engines.
 - Regulates fuel-air into suitable proportions.
- Fuel pump - forces fuel into the carburettor.
- Delivery pipe - connects all the devices.

Maintenance

- Cleaning the carburettor regularly.
- Cleaning the fuel filter in petrol.
- Cleaning the hole in the fuel tank cap.

The Diesel Fuel System

Consists of:

- Fuel tank - storage of fuel.
- Fuel injection pump - pumps diesel through injection nozzles and breaks into fine spray.
- Fuel filters - remove foreign particles from the fuel.
- Delivery pipes - connect the various devices.

Maintenance

- Replacing the fuel filter.
- Bleeding in case air is trapped in the system.

-
-
-

- Cleaning the sediment bowl regularly.

Structural and Functional Differences Between Petrol and Diesel Engines

before it gets into the engine.	cylinder.
<input type="checkbox"/> Fuel is ignited by an electric spark.	<input type="checkbox"/> Fuel is ignited by compression of air and fuel mixture in the cylinder.
<input type="checkbox"/> It produces little smoke because petrol is completely burnt.	<input type="checkbox"/> It produces a lot of smoke since the diesel is not completely burnt.
<input type="checkbox"/> Petrol engine is light in weight and suited for light duties.	<input type="checkbox"/> It is relatively heavy in weight and suited for heavy duties.
Petrol engine	Diesel Engine
<input type="checkbox"/> It has a carburettor	<input type="checkbox"/> It has an injection pump.
<input type="checkbox"/> Fuel and air are mixed in the carburettor	<input type="checkbox"/> The fuel and air are mixed within the

b

Electrical System

Consists of the following:

- Battery
 - Converts chemical energy into electrical energy.
 - Stores electrical energy produced by the running
- Ignition circuit - provide the electrical required by the spark plugs. current that produces a spark in the engine.
- Generator circuit - provide the electrical current that starts the engine.
- Lighting circuit - supply the electrical current required for the lighting system. Starter motor circuit - starts the engine.

Care and Maintenance of a Tractor Battery

- The level of electrolyte should be kept just above the plate by topping with distilled water.
- Corroded terminals should be scrapped clean and smeared with grease.
- The battery should be tightly fixed in a box to avoid spillage and damage.
- The battery should be fitted correctly on the tractor.
- The battery should be charged regularly and periodically.
- In case of long storage the battery contents should be kept upside down.
- The generator fan belt should always be functional to ensure the battery is always charged.

Ignition System

Consists of:

- Ignition - change the low voltage from the battery to high voltage current required by the spark plugs.
- Condenser - absorbs the self-induced current in the primary circuit.
 - stores current for a short time.
 - passes electric current to the distributor.
- Distributor - distributes the high voltage current to the spark plugs.
- Contact breaker - Interrupts the normal flow of current in the primary circuit.

State the Maintenance practices carried on the Ignition System

- The carbon deposits on the spark plug electrodes should be removed.
 - The spark plugs whose electrodes are worn out should be replaced.
 - The contact breaker points should be cleaned.
 - The breaker points should be adjusted so that they lie between 0.30mm and 0.50mm.
- The condenser should be replaced regularly.
The ignition systems should always be kept dry.
Ignition wires with poor insulation should be replaced.

Cooling System

- The cooling system aims at preventing the engine from overheating which would cause piston seizure in the cylinder.
- Some tractor engines are cooled by air while others are cooled by water.

State the Characteristics of Air Cooled Engines

- They are simple in construction.
- They have fins and a fan blade which assists the circulation.

-
-
-

- They are light in weight for they have no radiators and water jackets.

Limitations

- They get hot quickly and use heavy lubricating oil.
- The cooling is not adequate under all conditions especially when carrying heavy loads.

Water Cooled Systems

- It consists of the radiator, water jackets, water hoses, water pump, thermostat and a fanning mechanism.
- Water is used to absorb heat from the engine block at a reasonable rate.

Care and Maintenance of Water Cooling system

- The water pumps should be lubricated regularly.
- Clean water should be used in the radiator and trash removed from the fins.
- All pipes should be fitted tightly to avoid blockage.
- The radiator should be filled with clean water before starting the day's work.
- Fan belt tension should be checked regularly and if too tight or too loose should be adjusted accordingly.

Lubrication System

- This system is aimed at supplying oil to all parts of the engine where friction is likely to occur.

Importance of Lubrication system

- It helps to increase the efficiency of the machine and reduces the rate of wear and tear of moving parts.
- It reduces the heat created by the rubbing surfaces and acts as a seal between them.
- It acts as a cleaning agent because it washes off all the dust, dirt, soot and metal chippings from the oil paths to the sump.

Types of Lubrication Systems;

-
-
-

Splash feed type

Force feed type

Oil mist type

Types of Lubricants

- SAE 10 - This is thin engine oil which gives little protection when heated.
- SAE 50 - This is thicker engine oil which is recommended for protecting the bearings.
- SAE 90 - 100 - These are transmission oils which are recommended for clutch, gear box, wheel lubrication and ball bearings.

Note: SAE - Society of Automobile Engines.

Care and Maintenance of Lubrication Systems

- Old or contaminated oil should not be used for lubrication.
- Oil should be drained when still hot to avoid sticking on the walls of the sump.
- The oil filters should be replaced when necessary.
- The correct type of oil should be used as per the manufacturers' instructions. **Power Transmission System**

- The function of this system is to transfer power from the tractor engine to the drive shaft, the wheel axle, the power take off shaft and the hydraulic system.
- The system consists of the clutch, gear box, differential and the final drive.

The power transmitted from the engine is made available for use through the following:

- The propeller shaft - it connects the gear box to the differential.
- The power take off shaft (PTO shaft) -It is located at the rear part of the tractor and rotates at the same speed as the crankshaft of the engine.
- Hydraulic system - it is operated by the use of a lever near the drivers seat.
- It is connected to the 3-point linkage and helps to lower or raise implements mounted on the 3-point linkages such as ploughs, mowers, planters and sprayers. □ Draw bar –
 - It is a one-point linkage at the rear part of the tractor.
 - It serves for the attachment of trailed implements that can be used during harrowing, transportation or rolling.

Tractor Servicing

- The aim of tractor servicing is to keep the tractor in good and efficient working conditions.
- Tractor servicing is either;
 - short
 - long term.

List the Short Term Tractor Servicing

It includes:

-
-
-

- Checking the engine oil daily by use of a dip stick.
- If the oil level is low, it should be added.
- The fuel level should be checked at the start of every day's work and added if necessary.
- Water level in the radiator should be checked and if possible topped up.
- The level of the electrolyte should be checked daily and topped up with distilled water accordingly. □
Nuts and bolts should be tightened every day.
- Lost nuts and bolts should be replaced before the day's work.
- Grease should be applied by use of grease gun through the nipples.
- Large sediments from the sediments bowl should be removed.
- The tyre pressure should be checked daily before the day's work.
- The fan belt tension should be checked to ensure that it deflects between 1.9cm and 2.5cm when pushed.
- The brake shaft bearing should be greased.
- The brake fluid level is maintained at the recommended level.

Long Term Services

- The engine oil should be drained completely from the oil sump and replaced with new oil.
- The gear box oil should be checked and refilled as recommended.
- The oil in the differential should be replaced as recommended.
- The linkage and the pulley attachment should be greased.
- The pulley oil level should be checked and added if need be.
- The dirty oil should be removed and replaced with clean one.

Farm Machinery

Tractor Drawn Implements

- These are implements which are attached to the tractor during operation.

State the two categories. Tractor Drawn Implements

- One-point hitch implements ;
 - Are attached to the tractor at only one point that is, the draw bar.
 - They include all trailed implements such as the trailers, heavy harrows, planters and rollers.
- Three point hitch implements;
 - Are implements attached to the tractor at three points that is, the top linkage point and two lower linkage points.
 - They are operated by the hydraulic system.
 - They include ploughs, most harrows, subsoiler, planters, mower, ridgers, sprayers and rotavators.

Trailers

- They are one-point hitch implements.
- They are used for transportation of goods.
- Small ones have two wheels while big ones have four wheels.

Maintenance

- All the moving parts should be lubricated.
- Tyre pressure should be adjusted to the correct pressure.
- Worn out tyres should be replaced.
- Loose nuts and bolts should be tightened, worn-out ones should be replaced.
- The implements should be kept under a shed during long storage.

Ploughs

- They are primary tillage implements.
- The common type of ploughs include:
 - Disc ploughs.
 - Mould board ploughs.

Disc ploughs

- It is made up of heavy steel concave discs of 60-70cm diameter.

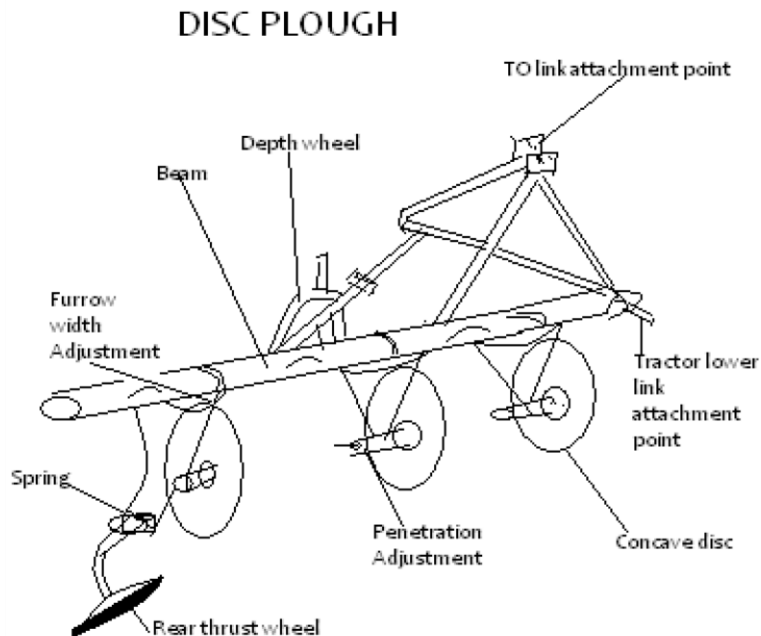

-
-
-

Parts and Functions of a disc plough

□ The hitchmast:

- Is an attachment for the three point hitch.
- Made up of two side links and a top link.
- These are parts connected to hydraulic system of a tractor for lifting and pulling.
- The beam: Supports all other parts. It also adds weight for better penetration.
- Depth wheel:
 - Used when driving on highway, ➤ it also controls the depth of ploughing.
 - May not be present in all disc ploughs.
- The standard or leg: Connects the discs to the beam.
- The hub: Allows the discs to rotate smoothly hence does the cutting of furrow slices. □ The scrapers: Remove the trash and mud or soil which cling to the discs, □ Disc blades: Cut and invert the furrow slices.
- Rear furrow wheel: Controls the depth of digging and stabilises the discs.

Adjustment

□

The cutting angle should be adjusted at 35° - 50° from the line of travel.
Achieved by pivoting the beam or the standard.

- Depth of digging: This is corrected by changing the height of depth wheel or adjusting hydraulic system and adding weights.

Care and Maintenance of Disc Plough

- Check for loose nuts and bolts and replace them.
- Sharpen the disc blades if blunt.
- Lubricate the rotating parts by use of oil/grease to reduce friction.
- Paint the exposed parts for example the beam/framework.
- Clean the implement at the end of each day's work before storage.
- Store the implements in a shed.
- The unpainted parts should be coated with old engine oil to prevent rust. Uses of a Disc Plough

Used in areas with the following conditions:

- Virgin land with many obstacles.
- Land with too much trash or tall vegetation.
- Opening up pasture land.

Mouldboard ploughs

- This primary tillage implement is suited in areas without obstacles such as stones, tree stumps, and roots.
- It gives a uniform depth of ploughing.

MOULDBOARD PLOUGH

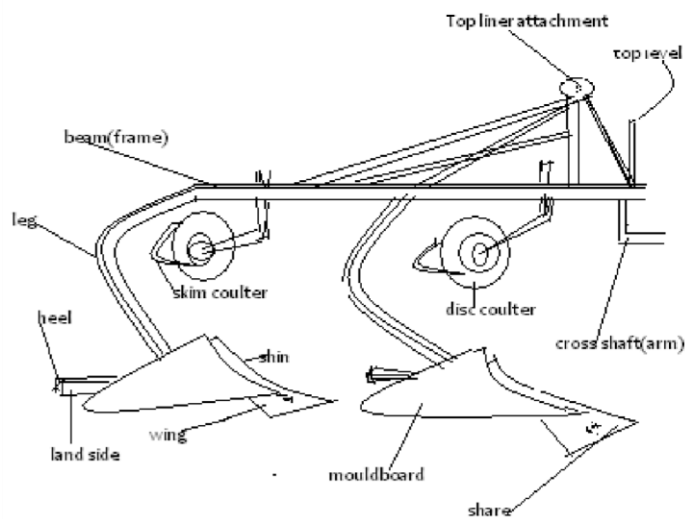

Parts and Functions Mouldboard ploughs

- **Share:** This makes the horizontal cut and starts the turning of the furrow slices.
- **Mouldboard:** Continues the turning of the furrow slices and pulverizes the soil.
- **Disc coulter:** Makes a vertical cut in the soil to separate the furrow slice from the un-ploughed land.
- **Skim coulter:** Removes any trash from between the furrow slices.
- **Frog:** It is the part where the share, mould board and the landside are attached.
- **Landside:** Stabilizes the plough and absorbs the side forces created when furrow is turned.
- **Shin:** Leading edge of a mouldboard.
- **Knife coulter:** Is a vertical knife which cuts trash and earth ahead of the share.

Care and Maintenance

- Lubricate the rolling parts for example wheel bearings and disc coulter bearings.
- Paint scratched parts of the plough.
- Sharpen the share or replace if worn out.
- Check all loose nuts and bolts and replace where necessary.
- Clean the implement after each day's work to remove soil, mud and trash.
- For long storage, keep under a shed and apply lubricants.

Adjustment

- **Depth:**
 - Controlled by raising or lowering the depth wheel.
 - Controlled by hydraulic control lever setting.
- **Pitch:** controlled by altering the length of the top link.
- **Front furrow width:** Controlled by cross shaft adjustment lever or by rotating the cross shaft crank.
- **Lateral levelling:** Controlled by tractor lift rod.

Operational differences between a disc and a mouldboard

Disc Plough	Mouldboard Plough
<input type="checkbox"/> Suitable on field with stones, roots and stumps.	<input type="checkbox"/> Cannot be used on fields with stone, roots or stumps.
<input type="checkbox"/> Does not invert the furrow slices completely.	<input type="checkbox"/> Inverts the furrow slices completely.
<input type="checkbox"/> More secondary operations are necessary after it has been used.	<input type="checkbox"/> Fewer secondary operations are needed.

<input type="checkbox"/> Cuts at varying points.	<input type="checkbox"/> Operates at uniform depth.
<input type="checkbox"/> Not easily broken by obstacles.	<input type="checkbox"/> Can easily be broken by obstacles.
<input type="checkbox"/> Requires less power to operate.	<input type="checkbox"/> Requires more power to operate.

Harrows

- They are secondary cultivation implements.
- There are different types of harrows. The common ones are:
 - disc, Harrows
 - spring tine Harrows ➤ spike tooth harrows.

Disc Harrows

- It comprises of a set of gangs with concave discs.

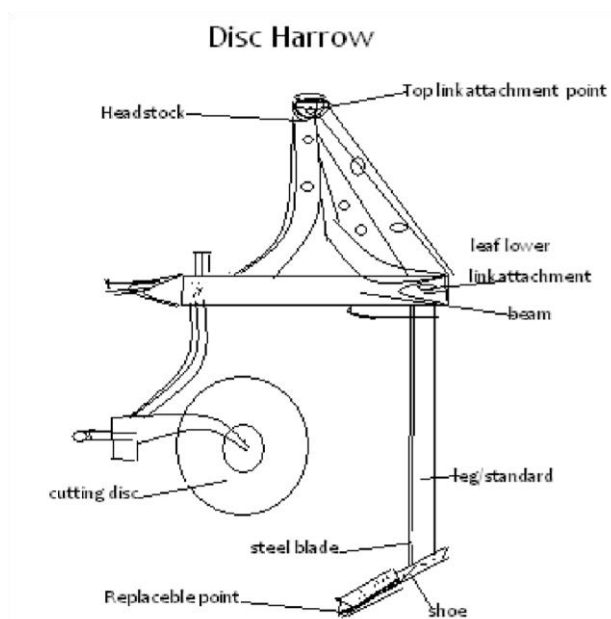

Uses

- Mixing the soil particles.
- Levelling the seedbed by breaking large lumps of soil.

- Killing weeds.

Disk harrows can be classified according to the arrangement of the gangs such as;

- s tandem, ➤ double tandem ➤ offset tandem.

Depth Adjustment

- Adding weights on the harrows.
- Use of hydraulic force.
- Use of light or heavy harrows.
- Use of regulating wheels.

Care and Maintenance

- Check for loose nuts and bolts daily. □ Lubricate the shafts and bearings.
- Clean and oil before storage.

Spring Tine Harrow

- Is made up of flat and curved tines which act as springs.

Uses

- Levels and smoothens the seedbed.
- Breaks the soil clods.
- Mixes trash and soil thus preventing wind erosion.
- Aerates the soil.

Adjustments

- Depth is controlled by the horizontal connecting link and depth wheel.
- For individual tine, use crossbar and loosening the screws.

Care and Maintenance

- Check for loose nuts and bolts and tighten them if necessary.
- Clean after use.
- Oil the lever mechanism.

Spike Tooth Harrows

- Consists of a metal framework with rigid metal spikes which break up the soil by vigorously hitting large lumps of soils as it is pulled through the soil. Uses
 - It smoothens and compacts the soil.
 - It breaks big lumps of soil into small particles.
 - Can be used for cultivating small crops if well set.

Subsoilers

- Heavy and require high horse power to pull.
- Ploughing depth of 51-90cm.

Functions

- Break up compacted soil.
- Break up the hardpan.

Care and Maintenance

- Clean it after use
- Check the point and if worn out, replace it.
- Oil when not in use.

Ridger

- It is double mould board plough used to make ridges and furrows.
- It is used to prevent water logging and draining through furrows for easy harvesting of root crops.

Rollers

□

This is an equipment used to compact the soil gently especially where tiny seeds are to be planted.

Rotavators: (Rotary cultivators)

- Work on the principles of high speed of revolving flail blades which beat and cut the soil together with trash.
- It is an equipment for both primary and secondary tillage operations. □ It is driven by the P.T.O. shaft of a tractor. Uses
- Breaks up large soil particles into small ones.
- Mixes the vegetation and the soil.
- Achieves two operations in one pass.

Adjustments

- Forward speed of the tractor gives a fine tilth of the seedbed done through the gearbox.
- Depth of work done by control of depth wheel.
- Slip clutch may break in case the knives come across obstructions

Mowers

Uses

- Cutting grass for hay or silage making, □ cutting overgrown grass □ clearing the field.

Reciprocating Mower

Parts and Functions

- Swath stick: Keeps the cut crop falling correctly. □ Swath board: To remove the cut crop.
- Shoe: Has a runner to absorb the weight and wear.
- Cutter bar: Is a flat bar which guides the fingers.
- Wear plate: Counteracts downward force and holds the knives.

Adjustments

- To adjust knife register by moving the whole bar away or towards the yoke.
- Knife lead: The outer shoe should be adjusted to be outer than the inner shoe by 4cm.

Maintenance

- Check for loose nuts and bolts and tighten where necessary.
- Keep knife section sharp.
- Lubricate the knife parts.
- Check knife to ledger plate cup for best cutting. □ Keep all the parts tight.

Rotary Mowers

- Cutting edge consists of two blades fitted opposite to each other on horizontal disc.
- The cutting blades swing round at high speed horizontally to the ground hence cutting is effected.

Adjustment and Maintenance

- Blades should be sharp.
- Guards to be fitted around the blades to protect the operator from flying objects.
- Lubricate the P.T.O. shafts.
- Check the gear-box oil regularly and fill to the right level if necessary.

Planters

- They are machines used for sowing seeds.
- There are two types:
 - Row crop planters.
 - Seed drills.

Functions of the Planters

- Meter the seed and fertilizers from seed and fertilizer hopper.
- Open the seed furrow.
- Deposit the seed in the furrow through the delivery tubes.
- Cover the seed

Functions of Parts of a Seed Plate

- Filler plate: gives proper seed depth.
- False ring: allows the seed to fall from the seed plate into the boot.
- Knockout pawl: pushes the seeds out of the cell by the roller action.
- Cut-off pawl: prevents more than one seed remaining in a plate cell.
- Cells: shaped holes to hold the seed.

Adjustments

- Adjust the coulters depth for the right crop.
- Fix the right seed plate.
- Place the planter in the level position.
- All the shafts should be free to turn.

Care and Maintenance

□

-
-

- Check all loose nuts, bolts and tighten them.
- Clean and oil the planter after use.
- Grease the drive sprockets regularly.

Seeders

- The grain drill sows grains of wheat, barley, oats, peas, beans and alfalfa seeds.

Parts that can be adjusted to change the sowing rate;

- Select the side of the feed wheel recommended on the drill charts for the seed-rate. Change the speed of the wheels by changing the gears or sprockets or both.

Change the position of the feed gate in the cup.

Use reducers below the feed wheel.

Care and Maintenance

- Keep seed and fertilizer hoppers dry and clean after each day's work.
- Check the drive shaft and lubricate them.
- Paint the parts for example fertilizer hopper to be shiny

Combine Harvester

Use

- Harvesting cereal crops for example maize, wheat and barley.

It is designed to do the following:

- Cutting ➤ Threshing.
- Winnowing
- Bagging

Parts of a Combine Harvester

- Cutter bar - cuts the grain head.
- Pick up reel- direct crop into the cutter bar,
- Elevator - channels the cut grain to the threshing drum.
- Winnowing fan - fans trash up onto a straw walker and directs it out of the combine harvester.
- Delivery tube - delivers the clean grains into a collecting tank from where it is bagged.

Maintenance of a Combine Harvester

- Loose nuts and bolts should be tightened.
- Remove all foreign materials stuck in the machine at the end of the day's work.

Ridgers

- They are used for harvesting tuber crops and for making furrows or ridges.

□

Maintenance

- Lubricate the moving parts.
- Clean the implement after use.
- Store under a shed.
- Repair or replace worn-out or broken parts.
- Loose nuts and bolts should be tightened.
- Unpainted parts should be oiled during long storage.
- Shares should be sharpened if blunt.

Foragers

- They are tractor mounted and operated by power from the P.T.O. shaft .
- Used for harvesting forage crops such as Napier grass, sorghum and maize.

Maintenance

Tighten loose nuts and bolts.

-
-

Lubricate moving parts.
Store in a shed.

- Clean after the day's work.
- Repair/replace worn out or broken parts.
- Unpainted parts should be oiled to prevent rust.

Maize Shellers

- These are stationary implements which are either hand or tractor driven.
- They consist of a rotating disc which shell maize grains from cobs.

Maintenance

- Greasing moving parts.
- Removing any stuck maize cobs.
- Repair or replace worn out or broken parts. □ Store in a shed.

Animal Drawn Implements

Ox Plough

- Ox-plough is a simple type of a mouldboard plough which is pulled by a pair of oxen, donkeys or camels.

Ox-Plough

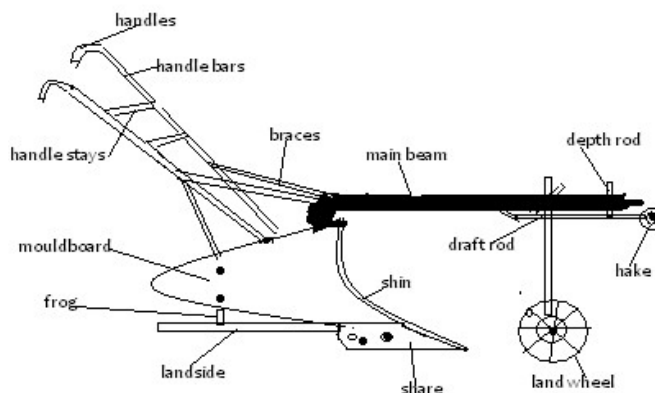

-

Explain the functions of the following parts of an ox-plough

- Main beam - It is the main component onto which all the other parts are attached. Mouldboard - It inverts the cut furrow slice upside down.
Plough share -It cuts the furrow slices.
Land wheel- It regulates the depth of plough.
- Draft rod - It is on this rod that a chain is connected on which a yoke is linked.
- It forms the draught mechanism of the plough.

What are the Advantages of an Ox-Plough Over Tractor Drawn Plough ?

- Less skill is required to operate it.
- Useful where tractors cannot be used for example steep slopes. □ Cheap to buy and maintain.

What are the disadvantages of an Ox-Plough Over Tractor Drawn Plough ?

- Much time is wasted in training oxen.
- Tedious and laborious to the driver of the animals and the controller of the implement.
- Animals can be sick or in poor physical state.
- Extra land is required as grazing fields for the oxen.

Adjustments

- Depth of plough is controlled by the land wheel and draft rod

Care and Maintenance

- Sharpen or replacing of the worn out share
- Replacement of worn out parts such as hooks and draw bar assembly.
- Oiling the shiny parts e.g mouldboard □ Wash off the soil after use.
- Paint the handles, beam and braces to prevent rusting.

Ox-Drawn Cart

- These are small carriages harnessed to the animals by a yoke □ The small carts have only two wheels bigger ones have four.
- They are pulled by animals in singles or in pairs □ Carts are used for transport.

Maintenance

-
-

- Moving parts should be oiled
- The yoke should be repaired when worn out or replaced if not repaired
- Tyre pressure should be checked and adjusted accordingly □ Repair other damages on the cart.

Agricultural Economics III: (Production Economics)

Introduction

- The agricultural sector is a key player in the economy of our country.
- It is a major employer and brings a lot of national income through foreign exchange.

National Income

- These are the total earnings from goods and services produced by a country in a period of one year.

Relationship Between Firm and Household

- A household is considered to be a unit comprising a farmer and family members.
- It produces raw materials and consumes manufactured goods.
- A firm on the other hand, is any manufacturing or processing unit which consumes raw materials and produces manufactured goods.
- Both household and firm generate income, which in turn, is used to:
 - Improve the standard of living of the household members by paying for essential goods and services.
 - The firms build more industries to create more employment and revenue through salaries and wages.
 - Finance government projects through taxes and hence further national development.

Gross Domestic Product (G.D.P.)

- This is the sum total of all goods and services produced in a country in a period of one year.

Gross National Product (G.N.P.)

- Is the sum total of G.D.P. and the difference between income inflow (revenue coming into the country from outside) and income outflow (money going out of the country by foreign investors). □ It represents the total income earned within the country and from abroad.

Per Capita Income

- Is the Gross National Income (in terms of revenue) divided by the number of people living in the country.
- It is not a good measure of the economic well-being of the people because of the uneven distribution of income among them.

Contribution of Agriculture to National Development

- The interaction between household and the firm generate income which is used to finance further expansion of the firms.
- This creates more employment and revenue.
- The government taxes the income to finance national development programmes such as;
 - health,
 - education,
 - water, energy
 - communication.

Factors of Production

- A factor of production is anything that contributes directly to output, that is, it is a productive resource.
- Productive resources usually employed in the production of goods and services. Include:
 - Land
 - Labour
 - Capital
 - Management

Land

- As a factor of production, refers to the natural characteristics and properties of a given area of land.
- The key factor here is productivity for example soil fertility, presence of water and minerals and is always fixed and has no geographical mobility.

Labor

- Besides being a consumer, human beings are also a factor of production.
- They provide the labour force (human power) required in the production process.
- Labour is assessed in terms of productivity and not mere numbers of workers or labourers.
- Labour is measured in terms of man hours, man days or man months. The labourer's productive capacity depends on such factors as;
 - age,
 - health,
 - state of nutrition ➤ level of education.
- The amount of work and the efficiency with which it is performed determines the quality of labour.

Capital

- Capital refers to all man-made assets that help land and labour to produce.
- It is categorized into:
 - Fixed/durable;
 - Working capital
 - Liquid capital

Fixed/durable;

Capital for example

- machinery,
- buildings
- permanent improvements on land like fences,
- roads,
- irrigation facilities □ water supply system.

Working capital;

Which include consumer goods such as;

- fertilizers,
- livestock feeds, □ fuel in store, □ pesticides.

Liquid capital;

For example;

- ready money,
- bank deposits, □ shares in financial institutions.

Management;

- It is a process of decision making in the farm.
- Managers use their knowledge and judgment to decide how to combine the other three productive resources in the best way possible.
- They make plans, execute them and bear the risks or consequences which such plans entail.

Production Function

Definition

- Production function is a physical relationship between inputs and outputs in a production process.
- It tells the quantity of output (product) that may be expected from a given combination of inputs.
- Production function may be expressed in table form or graphically as a curve.

Examples:

Feeding pigs for pork production at varying levels of concentrate feed.

1.

Unit of feed	Body wt. Gains (kg)	Marginal products (kg)
0	212	-
10	222	10
20	238	16
30	251	13
30	261	10
50	269	8
60	275	6
70	280	5
80	283	3
90	285	2
100	286	1

Types of Production Functions

- A production function assumes three forms which may be treated as different types:
 - Increasing Returns
 - Constant Returns
 - Decreasing (Diminishing) Returns

Increasing Returns

- In this type, each additional unit of input results in a larger increase in output than the preceding unit. □ This shows that resources are under utilized.

Constant Returns

- The amount of the product increases by the same amount for each additional input; that is constant returns to input factor. □ Again here resources are under utilized.

Decreasing (Diminishing) Returns

- Here, each additional unit of input results in a smaller increase in output than the preceding unit.
- Resource use is stretched to the maximum.
- It is the most commonly encountered form in agricultural enterprises; □ It gives rise to the law of Diminishing Returns.

Examples:

- Feeding dairy cows for milk production with varying amounts of feed.
- Crop responses to application of varying amounts of fertilizers.
- Use of varying units of labour on fixed unit of land.

Economic Laws and Principles

The Law of Diminishing Returns

- The law of diminishing returns states that; "if successive units of one input are added to fixed quantities of other inputs a point is eventually reached where additional product (output) per additional unit of input declines."
- This law is encountered practically in all forms of agricultural production.
- It is useful in determining the most rational and profitable level of production.

Example:

Production of maize at varying levels of N.P.K. fertilizer application on a fixed area of land.

Unit of NPK Fertilizer (bags)	Total Yields	Marginal Products (bags)
30	10	-
60	27	17
90	42	15
120	56	14
150	63	7
180	65	3
210	65	0
240	60	-5
270	52	-8
300	42	-10

Zones of a production function curves

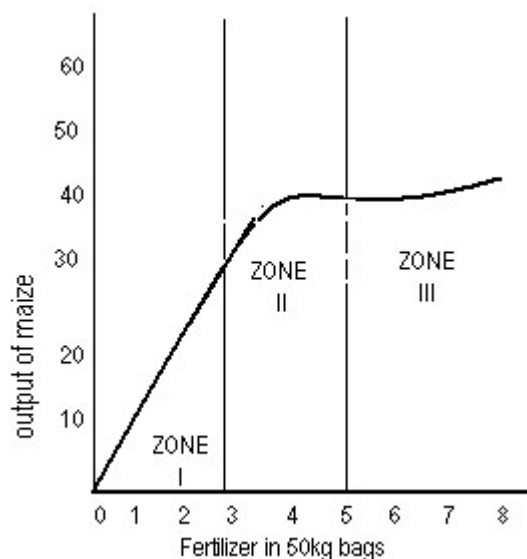

Zones of a production function curves these are:

- Irrational zone or Zone I.
- Rational zone or Zone II ➤
- Irrational zone or Zone III.

- The three zones are arrived at by drawing two perpendicular lines through the production function curve, one at $MP = AP$ and another at $MP=O$.
- In Zone I resources are not fully utilized while in Zone III, excessive application of resources leads to production decline or loss.
- It is not economical to produce at these levels.
- In Zone II resources are maximally utilized resulting in maximum production.
- It is therefore economical (or wise) to produce at this level.

Principle of Substitution

States-”if the output in a production process is constant, it is profitable to substitute one input factor for another, as long as it is cheaper than its next alternative.”

- This principle is applicable in a situation where more than one variable input factors are used.
- For example feeding hay and concentrates for milk production, farmyard manure and phosphatic fertilizers in the production of maize.
- The basic problem that the producer wishes to solve when two input factors are used in combination is in what proportions must the variable inputs be combined in order to produce at a minimum cost and hence attain maximum profit.
- To solve the above problem, the producer must determine the least cost combination of inputs used.
- The least cost combination is attained at a point where the Marginal Rate of Substitution (MRS) equals the inverse of price ratio of the factors involved.

That is:

$$\Delta X_2 = P X_1$$

$$\Delta X_1 = P X_2$$

X_1 - first input factor

X_2 - second input factor

- change (increase or decrease)

P - price (cost of input factors)

Examples:

- Producing 20 bags of maize using varying combinations of farmyard manure and phosphate fertilizers.
- Price of farm yard manure (FYM) is KShs10/- per unit and that of phosphate fertilizer is Kshs 50/- per unit

X_1 (P-fert)	x_2 (N-fert)	$\frac{\Delta X_2}{\Delta X_1}$ (MRS)
100kg units	100kg units	
1	9.00	-
2	4.00	5.1
3	2.80	1.20
4	2.40	0.40
5	2.00	0.40
6	1.80	0.20
7	1.65	0.15

8	155	0.10
9	1.45	0.10
10	1.45	0.05

In the above example, the following assumptions are made:

- A fixed quantity of output is to be produced.
- Input factors in combination substitute for one another at varying rates.
- Relative prices of input factors do not change drastically during the period of production.

NOTE: one input factor substitutes for the other at diminishing varying marginal rate of substitution.

Principle of Equimarginal Returns

- This principle states, "That the last unit of an input factor spent in one enterprise yields a marginal return exactly equal to the marginal return earned from the last unit invested in each of the other enterprises."

Example

- If the last shs.100/- spent buying cattle feed will return more than shs. 100/= spent on buying fertilizer for growing maize, then it is advisable to purchase more feed up to a point where the last shs.100/- spent on it will return exactly the same as the last shs.100/- spent on fertilizers.
- This concept is only relevant in a situation where farmers do not have adequate capital to employ inputs up to the level where marginal revenue equals the marginal cost.

The principal of Profit Maximization

- The profit is defined as the difference, in monetary terms, between the total returns (income) and total costs (expenses) in a production process.
- Profit maximisation aims at obtaining the highest returns at a minimum cost per unit of input factor used.
- This can be done by considering two concepts.

Marginal Concept

- Profit is maximised when the marginal (additional or extra) revenue (MR) is equal to, or slightly higher than, the marginal cost (Mc).
- At this point every added input factor brings in higher returns than the expenses incurred in investing it.

Net Revenue Concepts

- Profit is said to be maximized in a production process when the Net Revenue (differences between total revenue and total costs) is the highest that is ; $NR = TR - TC$.

- This is arrived at by analyzing the total cost and total revenue earned from a particular enterprise and then subtracting the former from the latter.

When calculating the profit using whatever concept, the following assumptions are made:

- Cost of inputs (such as fertilizers, labour) remains constant during the period of production.
- Price of the produce (product) remains unchanged. □ Fixed costs are ignored that is only varying costs directly involved are considered.

Farm Planning

- Planning is the process of establishing the organizational objectives and defining the means of achieving them.

Factors to consider in drawing a farm plan.

- Size of the farm.
- Environmental factors.
- The current trends in labour markets.
- Farmer's objectives and preferences.
- Possible production enterprises.
- Existing market conditions and price trends.
- Availability and cost of farm inputs.
- Government regulations/policy.
- Security.
- Communication and transport facilities

Farm Budgeting

- Farm budgeting is the process of estimating the future outcomes of a proposed farm plan,
- That is; the future incomes and expenses of a farm plan.

Importance of Farm Budgeting

- It helps the farm in decision making.
- It helps the farmer to predict future □ returns that is planning ahead.
- It helps the farmer to avoid incurring losses by investing in less profitable enterprises.
- It helps the farmer to secure loans from financial institutions such as Agricultural Finance Corporation and commercial banks.
- It ensures a periodic analysis of the farm business.
- It acts as a record which can be used for future reference. □ It pinpoints strengths or weaknesses in farm operations.

Types of Budgets

Partial Budget

- It represents financial effects on minor changes in a farm organisation.

- It is necessary when a farmer wants to replace or reduce enterprise.

Complete Budget

- A complete budget is necessary when the farmer wants to start a new business where both the variable costs and the fixed costs are likely to be affected. □ It involves a major change or reorganization in the farm business.

Agricultural Services Available to the Farmer:

- Agricultural production efficiency is greatly increased by services rendered to the farming communities by;
 - Government institutions
 - Non-governmental organizations.

Some of these services are:

- Extension and Training:
- Banking Services:
- Credit:

Extension and Training: □ In the field and in farmer's training centres.

Banking Services:

- These enables the farmers to save some of their farm income and invest them in future projects. **Credit:**
- Credit is a financial assistance advanced to agricultural farmers to finance their farm projects and repay it with interest. □ It is a borrowed resource.

Types of Credit

- Credit is categorised according to;
 - Time of repayment
 - The types of projects to be financed.

Examples are:

Short-term Credit

- Repayable within one year and is advanced for the purchase of;
 - seeds,
 - fertilizers,
 - animal feeds .

Medium-term Credit

- Repayable within 2 - 5 years and is used to finance projects such as;
 - fencing materials, ➤
 - purchase of livestock, ➤
 - light farm equipment .

Long-term Credit

- Repayable period is up to 15 years and even more.
- It is given for the long-term or durable projects such as;
 - purchase of land,
 - construction of soil and water conservation structures,
 - farm buildings,
 - irrigation projects for perennial cash crops for example;
 - ❖ coffee, ❖ farm machinery ❖ implements.

Sources of Credit

- Co-operative societies and unions.
- Crop boards.
- Commercial banks.
- Agricultural Finance Corporation.
- Insurance companies.
- Individual money lenders.
- Settlement fund trustee.

Artificial Insemination Services:

- Provides farmers with semen from improved or superior bulls to improve their livestock herds through controlled breeding.

Agricultural Research Organization

- These develop and pass on to farmers, improved production techniques as well as crop and livestock species with better performance in different ecological zones.

Marketing Outlets

- These are agencies that ensure effective and efficient conveyance of farm produce to points of processing and consumption.
- They are largely crop marketing boards or corporations and cooperative societies.

Veterinary Services

- In the field are veterinary officers who help the farmer in treating and controlling livestock diseases and parasites.

Farm Input Supplies

- Farmers are able to obtain their farm inputs from organizations such as co-operatives and private companies.
- These organizations bring inputs closer to the farmers for example Kenya Farmers Association and private agrovets.

Tractor Hire Services

- This involves hiring of tractors and machinery at a cost by farmers who are not privileged to own their own.

Sources

- Ministry of Agriculture □ Private contractors.
- Individual farmers. □ Other service providers.

Risks and Uncertainties in Farming

- Uncertainty-is the state of not knowing about future events or outcomes.
- Risks-is the difference (divergence) between the expected and the actual outcome.

Types of Risks and Uncertainties

- Fluctuation of commodity prices.
- Physical yield uncertainty.
- Ownership uncertainty.
- Outbreak of pests and diseases.
- Sickness and injury.
- New production technique.
- Obsolescence for example machinery may become outdated or obsolete within a short time.
- Death of either farmer or livestock.
- Natural catastrophies such as;
 - floods,
 - drought,
 - earthquakes,
 - storm and strong winds which may destroy crops or kill the animals.

Ways in Which Farmers Adjust to Risks and Uncertainties

- Diversification.
- Selecting more certain enterprises.
- Contracting.
- Insurance.
- Input rationing.
- Flexibility in production methods.
- Adopting modern methods of production.

Agricultural Economics IV: (Farm Accounts)

Introduction

- Financial and physical records if accurately kept in the farm serve as very important tools in decision-making.
- The records are kept in several books and statements as follows: **Financial Documents**

They include:

- Invoices.
- Receipts.
- Delivery notes □ Purchase records.

An Invoice

- This is a document issued by the seller to the buyer for goods taken on credit, and payment to be done later.
- The original is given to the buyer and duplicate retained by seller.

The invoice shows the following:

- The buyer and seller.
- Date of transaction.
- Amount involved.
- Invoice number.

A Receipt

- This is a document issued by the seller to the buyer when cash payment for goods delivered is made.

It shows the following:

- The buyer and the seller.
- Date of transaction.
- Amount involved.
- Serial number

Delivery Note

- It is a document which shows that the goods have been delivered.
- The receiver verifies the goods and then signs on the delivery note.

Features:

The delivery note shows the following:

- Goods delivered as per order.
- Quality or condition.

- People involved in the transaction.
- Date of delivery. **Journal:**
- It is a book of first entry showing a record of all business transactions arranged in the order in which they occur.
- Its pages are divided vertically into five sections.
- The information is posted to the ledger **Inventory:**
- This is a list of all the possession/assets item by item and their market value.
- Such items are land, livestock, tools and equipment and crops in the store.
- Valuation is an estimation of the value of each asset or item, based on market price or cost of production.

Local Purchase Order:

- Issued by the purchasing officer of the supplier for example school.
- It shows people involved in the transaction, types and amounts of goods ordered and dates.
- It should be written and signed by the authorised officer.
- It is written in duplicate and the original is given to the supplier.

Financial Books

Ledger:

- Is a book which contains individual accounts.
- It is a principle book of accounts in which entries contained in all the other books are entered.
- It is a storehouse of all the transactions.
- Each page is numbered and vertically divided into two equal parts namely credit and debit.
- Each part is further sub-divided into four sections. **Cash Book:**
- It is a book where transactions involving cash or cheque payments are recorded.
- It involves cash or cheque payments and receipts.
- It is divided into two parts - debit and credit side.
- All the receipts of cash or cheque are recorded on the debit and all payments are recorded on the credit side.

Example: Enter the following entries in the cash book.

- 1.7.05 -Received shs.2,000 from Ndete by cheque.
- 2.7.05-Bought D.A.P. fertilizer and paid cheque of shs. 5,000.
- 3.7.05-Received shs.5,000 cash from Ngala.

- 4.7.05 -Paid water bill for shs 400 in cash.
- 9.7.05-Paid telephone bill of 1,500 by cheque.
- 11.7.05 -Deposited shs.2,000 in the bank.
- 20.7.05 -Withdrew shs.2,000 from the bank for home use.

Cash Book record

DR				CR			
Date	Details	Cash	Bank	Date	Details	Cash	Bank
1.7.05	Received from Ndete		2,000	2.7.05	D.A.P		5,000
3.7.05	Received from Ngala	5,00		4.7.05	Water bill	400	
11.7.05	Cash	02,000		9.7.05	Telephone bill	500	
				20.7.05	Cash		2,000

Financial Statements

Cash Account Sheet

- It involves the recording of sales and receipts, purchases and expense.
- Each sale or purchase is entered twice, once in the total column and once in the analysis column.
- The sum of all the entries in the total column should always equal the sum of the entries in all the other columns.
- The cash analysis account sheet is given above. **The Balance Sheet**
- It is a financial statement of assets and liabilities recorded on a given date.
- It shows the financial position of a farm business at a glance (snapshot).

Assets are items owned by the farmer,

These include:

- Property (money, goods and buildings).
- Debts receivable from other people.
- Goods and services paid for in advance.

Assets can be divided into two:

- Fixed assets: assets of permanent nature and not easily converted into cash.
- Current assets: assets which can be easily converted into cash.

- Liabilities are claims to the farmer's property such as bank overdraft and debts payable.

They are divided into:

- Current liabilities - debts which must be paid within a short time.
- Long term liabilities - debts which are payable over many years or over a long period.

Profit and Loss Account

- Prepared at the end of a calendar year.
- It is a final account which summarises the sale and receipts (income flowing in the business) and the purchases and expenses (flowing out of the business).
- **Note:** If assets are more than liabilities then the balancing factor is net capital (in the liability side) hence the farm business is said to be solvent.
- If the liabilities are more than the assets, then the balancing factor is a loss (in the asset side) hence the farm business is insolvent.
- To calculate profit or loss, account, valuation is done by having an inventory of all the assets.
- Valuation of the assets is determined by market price and cost of production for machinery and buildings as depreciation factor, is attached.

Format of a balance sheet Balance sheet of Katilo school as 31-12-2009

Assets	Shs	Cts.	Liabilities	Shs.	Cts.
Fixed Assets			Long-term Liabilities		
Land			Long-term loan for land development		
Buildings			Loans payable over 15 years		
Fences and other structures					
Current Assets			Current Liabilities -		
Livestock			-Debts payable		
Debts receivable			-Credits from friends		
Cash in bank			-Short-term loans		
Cash in hand					
Sub-total			Sub-total		
Total			Total		

Format
Profit and Loss Account of Kitheko Farm at 31-12-2009

Sales and Receipts	Shs.	Cts.	Purchase & Expenses	Shs.	Cts.
1. Income during the year			1. Opening valuation		
2. Debts receivable			2. Expenditure during the year		
3. Closing valuation Balance (being a loss)			3. Debts payable Balance (being farm a profit or net income)		
TOTAL			TOTAL		

Agricultural Economics V (Agricultural Marketing and Organizations)

Introduction

- Agricultural marketing is an economic activity which involves the distribution of farm produce from the farm to the consumer.

Market and Marketing

- Market is an institution for the exchange of goods and services or a place where selling and buying of goods takes place.
- Marketing refers to the flow of goods and services from the producer to the consumers.

Marketing Functions

- Transportation - Movement of goods from production centres to the consumption centres.
- Buying and selling - Purchase of goods from the producer to be sold to the consumer.
- Storage - Agricultural products are seasonal hence storage is necessary.
- Processing - Changing of raw form into utilizable form.
- Grading and standardisation - Sorting into uniform lots of certain qualities.
- Assembling - Collecting the farm produce from the farm to the market centres.

- Collecting market information – To know the prices, supply and demand of certain commodities.
- Advertising - Making the consumers aware of the produce.
- Bearing of risks - Such as fire risk, price fluctuation.
- Financing or expenditure on other processes.
- Packaging or putting into small packs and labelling.
- Packing or putting produce In containers such as bags.

Marketing Agencies and Institutions

Middlemen (itinerant trader) - are the people who buy from the producer and sell to other agencies.

- Wholesalers - Buy in bulk and sell to the retailers.

- Retailers - Buy from the wholesalers and sell in small units to the consumers.

Problems in Marketing Agricultural Produce

- Farm produce are bulky, that is weight and volume are high but low in monetary value thus difficult to transport.
- Most of the agricultural products are perishable for example milk, vegetables and fruits.
- Storage problems (since they are bulky they require a lot of space).
- Lack of proper transport system since agricultural products are in the rural areas and the market are situated in urban centres.
- Lack of market information hence farmers are exploited by middlemen.

Price Theory

- Price is the amount of money paid in exchange for goods or services.
- Price theory is concerned with the determination of price of any commodity.
- Price is determined where demand for and supply of any commodity are equal to each other.

Demand

- It is the quantity of any commodity which is purchased at any price within a given time.
- The law of demand states that quantity demanded changes inversely with the price. Demand

Curve

- The curve slopes from left to right downwards.
- This means people buy more at lower prices and vice versa.

Demand Curve

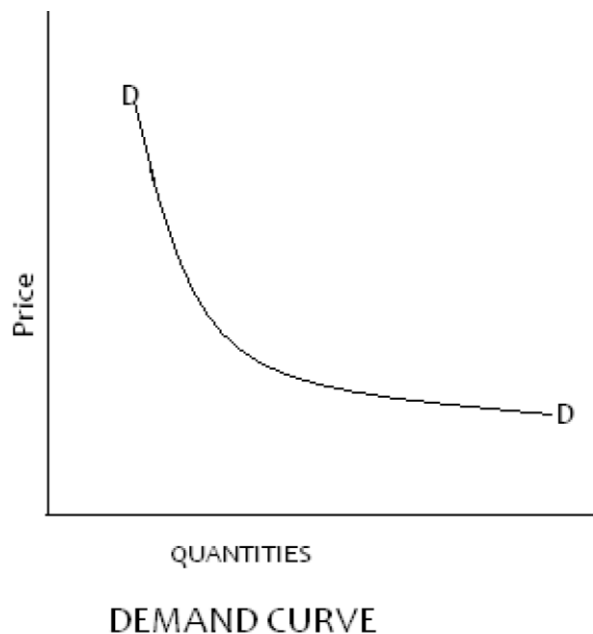

Factors Affecting the Demand of a Commodity

- Population
- Income of the consumer.
- New inventions.
- Taste and preference of the individual.
- Price of the substitute commodities.
- Price expectations. □ Advertisement.
- Culture and social values of the consumers.
- Price of commodities having joint demand for example tractors and diesel.

Elasticity of Demand

- It is the responsiveness of demand to a change in price.
- Elasticity of demand = $\frac{\text{Percentage change in quantity demanded}}{\text{Percentage change in price}}$

Types of Elasticity of Demand

- Elastic demand is one where the ratio is more than 1.
- Unitary elasticity is one where the ratio is equal to 1. □ Inelastic demand is one where the ratio is less than 1.

Supply

- Supply is the quantity of any commodity which is offered for sale at any price at a given time.

The law of supply states that when price rises, quantity supplied increases and when price falls quantity supplied decreases (other factors held constant).

The curve rises from left to right upwards.

This means that people are willing to offer more for sale at higher prices.

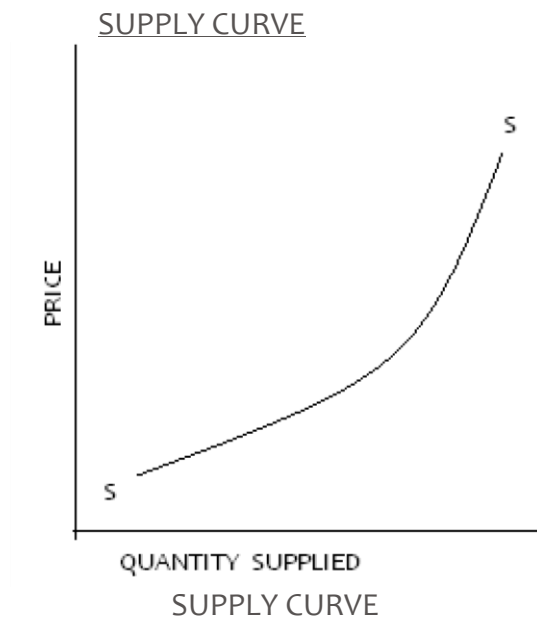

Factors Affecting Supply of a Commodity

- Number of sellers
- Price of substitute commodities.
- New technology.
- Price expectation.
- Peace and security.
- Weather conditions.
- Policy of the government.
- Cost of production of the commodities.

Elasticity of Supply

This refers to the rate at which quantity supplied changes due to a change in price level.

$$\text{Elasticity of Supply} = \frac{\text{Percentage change in quantity supplied}}{\text{Percentage change in Price}}$$

Elasticity of Supply= Percentage change in Price

Type of Elasticity of Supply

- Elastic supply one where the ratio is more than 1.

- Unitary elasticity of supply is one where the ratio is equal to 1. □ In elastic supply is one where the ratio is less than 1.

- One of the problems of agricultural produce is that supply does not readily adjust to price changes.

Equilibrium Price

- Is the price at which demand and supply are equal.
- That means whatever is offered for sale at the market is bought.
- In the graph below, the quantity supplied and demanded are equal at a price of Shs.300 and quantity of 80kg.
- At this point the price is higher than shs.300 then the supply will be greater than demand and there will be surplus hence price will fall.
- If, on the other hand, the price is less than shs.300 demand will be greater than supply hence shortage and rise in price.

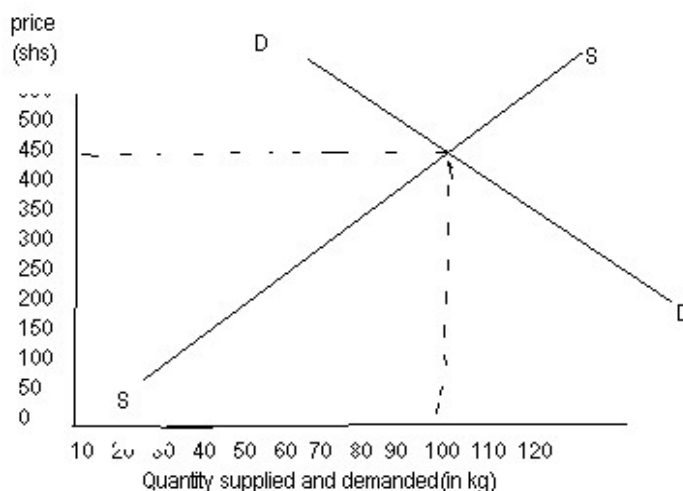

Agricultural Organization

- Agricultural organizations are agencies which, through their activities, promote agricultural development.
- These organizations are co-operatives and statutory boards.

Co-operatives

- A co-operative is an organisation of people with a common aim of pooling their resources to achieve their objectives.

Functions of Co-operatives

A co-operative society carries out the following functions:

- Collecting and assembling members' produce.
 - Processing the farm produce after collection.
 - Transportation of members' produce to market points.
 - Negotiation of fair prices with the purchasing agencies for the members' produce.
 - Purchase and distribution to members of farm inputs.
 - Storage of members' produce before transmission to market points.
 - Provision of credit facilities to members on easy terms.
 - Training and education of members on improved farming techniques.
 - Offering farm machinery services to their members on hire terms for farm operations.
 - Co-operatives may invest in other viable ventures and the profits realised are shared among members in form of dividends or bonuses.
- ### Formation and Structure of Co-operatives

The formation of a co-operative takes the following stages:

- Individuals with common interest collect together to form a primary co-operative society
 - At least ten (10) members qualify for registration.
 - Each primary co-operative society elect their office bearers consisting of chairman, secretary and treasurer.
 - Several primary co-operative societies are usually amalgamated to form a district cooperative union.
 - Tertiary co-operative unions are nationwide organizations to which the secondary co-operative unions are affiliated.
 - Examples are Kenya Planters Co-operative Union, Kenya Farmers Union, Kenya Cooperative Creameries, Co-operative Bank of Kenya, etc.
 - Apex organizations. This is represented in Kenya by Kenya National Federation of Co-operatives which is an affiliate of the International Co-operative Alliance.
- ### Problems Facing Co-operatives

Co-operatives encounter the following problems in their operations:

- Managerial problems arising from:
 - Financial mismanagement due to poor accounting.
 - Corruption and misappropriation of cooperative resources by the personnel in the system.
 - Lack of advisory services on technical operations.
 - Inability to meet the set obligations of providing credit facilities due to malpractices.
- The nature of agricultural products and associated problems.
 - Bulkiness hence difficulties in transportation and storage.
 - Perishability of produce hence difficult to sustain quality.
- Inadequate capital to invest in the cooperative undertakings.
- Transport problems due to poor roads.

➤ This hampers the produce getting to the market points in time. **Statutory Boards**

➤ A statutory board is an organization established by an Act of Parliament and charged with the running or managing of a certain industry within the government sector.

Marketing Boards

- Some of the statutory boards are charged with the marketing of certain farm produce and are thus called marketing boards.
- Examples are the Coffee Board, Pyrethrum Board, Cotton Seed and Lint Marketing Board, Tea Boards, National Cereals and Produce Board, Kenya Meat Commission, the Dairy Board of Kenya and others.
- Their marketing functions are to look for market and better prices.

Research Organization

- These are research centres which among other things, carry out research and trials on:
- Development of new varieties and cultivars of crops.
- Breeding disease and pest resistant varieties of crops and types of animals.
- Adaptations of crop and livestock species to ecological conditions of certain areas.
- Use of fertilizers and pesticides on crops in specific areas.
- Development of early maturing and high yielding species.
- Soil testing and crop analysis. Advisory services of agro-economic aspects.

Other Organizations

Kenya National Farmers' Union negotiates for:

- Reasonable and affordable prices of farm inputs.
- Better prices for farm produce.
- Better credit facilities.
- Better control of diseases and pest.

Agricultural Society of Kenya

- Organizes agricultural shows in the country.
- Encourages improvement of livestock through exhibitions and educating farmers □ Organizes the running of young farmers' clubs.
- Organizes and finances the ploughing contests during which farmers learn the modern techniques of seedbed preparation.
- Publish "Kenya Farmers" magazines.

Young Farmers and 4-K Clubs.

These are student organizations whose objectives are:

- To expose the young students and encourage them to appreciate agriculture as a profession in their career.
- To encourage the youth to develop leadership qualities through assignment of small farming projects.
- Organizing students exchange programmes with other club members both locally and abroad.
- To develop better farming skills through judging competitions, annual rallies and camps.

Agricultural Based Women Groups

- These are self-help groups whose objective is to uplift the economic status of their members by carrying out agricultural related activities.

Their success depends on the following factors:

- Commitment of their leaders.
- Motivation of the members.
- Sacrifice for each other.

Agroforestry

Introduction

- In Kenya land use is changing from extensive methods of farming to more productive and sustainable intensive methods.
- Agroforestry is a method of farming which has become increasingly important.

Definition

- This is the practice of integrating a variety of land use
- It combines tree growing, pasture and crop production practice on the same piece of land to improve the output of the land.

Forms of Agroforestry

- **Agroforestry;**
 - It is a combination of trees/shrubs and crops in agricultural production.
- **Silvopastoral:** ➤ It is a combination of growing tree/shrubs, pastoral and keeping of livestock. □ **Agrosilvopastoral:**
 - It is a combination of growing trees/shrubs, animals, pastures, and crops.

Importance of Agroforestry

- Environmental protection.
- Source of income.
- Afforestation for timber production.
- Maintenance of soil fertility.
- Aesthetic value.
- Labour saving in firewood collection.
- Source of food and feed.
- Source of fuel wood.

Important Trees and Shrubs for Particular Purposes

- Eucalyptus Spp;
 - Timber,
 - Bee forage,
 - Fuel wood,
 - Medicinal, ➤ Production of essential oils.
- Acacia Spp;
 - Leaves and pods eaten by animals,
 - Provision of shade.
- Cajanus cajan (pigeon peas);
 - Proteinous feed for human, ➤ Used as fodder ➤ Firewood.
- Croton megalocarpus(croton);
 - Fuel wood timber for poles ➤ Handles for hand tools.
- Erythrina abyssinica (flame tree);
 - Wood carvings,
 - Bee forage,
 - Nitrogen fixation ➤ Medicinal.
- Markhamia lutea (markhamia tree);
 - Timber for construction,
 - Shade, ➤ Soil protection, ➤ Bee forage.
- Grevillea robusta (silky oak.)
 - Timber,
 - Fuel wood,
 - Fodder,
 - Bee forage,
 - Soil protection, ➤ Wind breaker ➤ Shade.
- Sesbania sesban (sesbania);
 - Fodder,
 - Nitrogen fixation,
 - Shade, ➤ Fuel wood.
- Calliandra calothyrsus (calliandra);
 - Fuel wood,
 - Fodder,
 - Nitrogen fixation,
 - Shade, ➤ Bee forage.
- Persea americana (avocado);
 - Fodder,
 - Fruit production,
 - Shade,
 - Fuel wood.
- Mangifera indica (mango);

- Fruit production,
- Shade trees,
- Wind break,
- Soil protection, ➤ Fuel wood.

Characteristics of Agroforestry Tree Species:

- Fast growth rate.
- Deep rooted.
- Nitrogen fixation ability. □ By-product production ability.
- Be multipurpose in nature.
- Should not possess competitive ability with main crop ..
- Have coppicing and lopping ability.
- Have appropriate canopy - should not shade others.
- Nutritious and palatable.

Trees and Shrubs to Avoid at Certain Sites and Reasons

- Eucalyptus Spp.-should not be planted near water sources because it would absorb the water.
- Eucalyptus Spp. -should not be planted on the arable land as the roots have allelopathic effects on other vegetation including crops.
- Tall trees should not be planted near farm buildings because they may fall and damaging the buildings, their roots will break the building stones gradually.
- Bushy trees or shrubs should not be near farm buildings as they may harbour predators.
- Tall trees planted with main crop of a lower canopy intercept the rainfall, affecting the growth of the main crop.
- Cypress trees have leaves which produce acidity in the soil preventing undergrowth beneath the tree.
- These trees should not be planted within the farm but at the periphery. Tree Nursery
- Tree nurseries are structures used to raise tree seedlings until they are ready for transplanting.
- There are 2 main types: Bare root nurseries:

These are also known as 'Swaziland' beds where the seedlings are raised directly into the soil.

Advantages

- Cheap and less time consuming. □ Require less labour □ Occupy a small space.
- Many seedlings are raised in a small space.
- Transportation of seedlings is easy.

Disadvantages

- Root damage when uprooting the seedlings.
- Difficult to transport.
- Lower survival rate after transplanting.

Containerized nursery:

- The seedlings in this type of nursery are raised in containers such as pots, polythene bags or tubes and tins.

Advantages

- Higher survival rate after transplanting.
- No root damage.
- Successful in arid areas.

Disadvantages

- Labour intensive.
- Difficult to get containers.
- Sometimes it may be difficult to get the right type of soil to use in the containers.

Seed Collection and Preparation

Seed Collection

Seeds should be collected from;

- Adaptable trees,
- High yielding,
- Healthy
- Resistant to pests /diseases.
- The mother plant should be identified first.

The following methods used to collect seeds.

- Shaking the tree.
- Gathering from under the tree.
- Lopping of the tree.
- Climbing on the trees.
- Hooking method.

Seed Preparation

- This done when seeds are collected from a fresh fruit, they should be soaked in water, then washed and dried.
- Cleaning and sorting: done to remove immature seeds, rotten seeds, broken or damaged seeds.
- Drying: Done by sun-drying or oven drying.
- Seed testing: this determines;

- Seed quality for percentage purity,
- Seed weight,
- Moisture content,
- Germination percentage.
- Seeds should be stored in dry containers at room temperature.
- Seed treatment: seeds are treated first to break the seed dormancy and ensure rapid germination;
 - Hot water treatment: used to soften the seed coat to make it more permeable to water.
 - Examples of seeds which require this treatment are leucaenia, calliandra and acacia.
 - Mechanical breaking: done by nicking the seed coat with a knife for easy entrance of water for example seeds of croton trees.
 - Light burning: applied to the wattle tree seeds.

Nursery Management

The following are the practices carried out in the nursery when the seedlings are growing:

- **Mulching:**
 - Aim is to reduce excessive evaporation,
 - Moderates the soil temperature,
 - When it decays it improves the soil structure,
 - Reduces the impact of the raindrops.
- **Weeding:**
 - Done to reduce competition for growth factors by uprooting the weeds,
 - Use a sharp pointed stick. □ **Watering:**
 - Done by use of a watering can
 - Done twice a day in the morning and in the evening.
- **Pricking out:**
 - It is the removal of seedlings in an overcrowded area to another nursery bed,
 - This allows the seedlings to grow strong and healthy. □ **Root pruning:**
 - It is the cutting of the roots longer than the pots.

Root pruning is done for the following reasons;

 - Make lifting easier
 - Encourage fast establishment.
 - Reduce damage to the seedlings.
 - Encourage development of a short dense and strong rooting system.
- **Shading:**
 - Done to reduce the intensity of sunlight .
 - Dark conditions should be avoided.

- Pest and disease control:
 - Use of appropriate chemicals,
 - Sterilization of soil through heat treatment, ➤
Fencing to protect seedlings against animal damage.
- Hardening off:
 - It is the practice of preparing seedlings to adapt to the ecological conditions prevailing in the seedbed.
 - It involves gradual reduction of shade and watering 1-2weeks before transplanting.
- Transplanting:
 - The practice of transferring seedlings from the nursery bed to the main field where they grow to maturity.

Procedure of Transplanting

- Holes are dug early before transplanting.
- Topsoil is mixed with compost manure.
- The seedlings are watered well a day before transplanting.
- The seedlings are removed from the nurseries carefully with a ball of soil for the bare root seedlings and roots trimmed for the containerized seedlings.
- The seedling is placed in the hole at the same height it was in the nursery.
- The container is removed carefully.
- The soil is returned into the hole and firmed around the seedling.
- The seedling is watered and mulched. Care and Management of Trees □

Protection:

- From damage by animals such as goats and cattle by eating the leaves.
- It is done by fencing the fields or using small poles around each seedling with or without wire nettings, can be done for individual trees or an entire field.
- Pruning and trimming:
 - Pruning is the removal of extra or unwanted parts of a plant.
 - The unwanted part may be due to breakage, overcrowding, pests or disease attacks and over production.
 - Pruning initiates growth of shoots and trains the tree to have the required shape.
 - Regular cutting back of the trees is known as coppicing,
 - It is done at the beginning of each cropping season to reduce competition for water, minerals, nutrients and sunlight with crops.
 - The materials pruned or coppiced are used as fuel wood or for fodder crops.
- Grafting old trees:
 - This is the practice of uniting two separate woody stems.
 - The part with the rooting system is known as root stock (base)

- The part which is grafted onto the rootstock is called a **scion** which has buds that develop into the future plant.
- The ability of the scion and the rootstock to form a successful union is known as **compatibility**.
- Methods of grafting include whip or tongue grafting, side grafting and approach grafting.

Agroforestry Practices

- **Alley Cropping/Hedgerow Intercropping:**
 - The growing of multipurpose trees and shrubs together with crops.

Benefits

- Improve soil fertility through nitrogen fixation and organic matter.
- Provision of green manure.
- Used as fence and mark boundaries.
- Acts as windbreaks.
- Suppress weeds.
- Source of timber and fuel wood.

- **Multi-storey cropping ;**

- This is the growing together of trees of different heights.
- The system is based on crops which can tolerate shading.
- The trees and crops form different levels of canopy which look like storey.

Benefits

- Increases water conservation for pastures.
- None of the crops or trees included will be shaded.
- Act as windbreak for crops.
- Creates suitable micro-climate in the area.
- Trees are used for timber, fuel wood and forage.

- **Woodlots (farm forests)**

- These are plots of land set aside for trees only.
- They are established in the hilly and less productive parts of the farm.
- Fast growing tree species such as Eucalyptus spp. should be grown.

Sites for Agroforestry:

- Farm boundaries - provide live fences.

- River banks - protect water catchment areas. □ Homesteads - provision of shade and windbreak □ Terraces - for soil conservation.
- Steep slopes - as contour hedges to encourage water seepage.

Tree Harvesting Methods

- Pollarding;
 - This is the extensive cutting back of the crown of the tree about 2-3 meters above the ground level to harvest all the side branches.
 - It stimulates the development of a new crown and branches.
- Coppicing;
 - Cutting the main stem of the tree completely at a height of 10 - 50 cm above the ground.
 - The tree should be cut in a slanting angle.
- Lopping or side pruning ;
 - The removal of selected branches of the tree ➤ Done to produce fuel wood and fodder.
- Shaking of the tree ;
 - This is a method of harvesting pods and seeds from trees without cutting the tree.
- Cutting back;
 - The tree is cut from the base to allow new growth as done in coffee when changing the cycle.
- Thinning;
 - The removal of some of the trees growing in lines to give the remaining trees enough space to grow.