

## INTRODUCTION TO AGRICULTURE

### K.C.S.E PAST PAPERS

1. 1996: What is plantation farming system?
2. 1997: State the main characteristics of shifting cultivation.
3. 1997: Differentiate between olericulture and pomoculture
4. 1997: State three characteristics of shifting cultivation.
5. 2001: State six reasons why agriculture is important in Kenya's economy
6. 2002: State two ways in which agriculture contributes directly to the development of industries.
7. 2004: Give the limitations of pastoral Farming.
8. 2004: State any two disadvantages of pastoral nomadism system of farming.

### FACTORS INFLUENCING AGRICULTURE

#### K.C.S.E PAST PAPERS

1. 1995: List four environmental factors that affect crop distribution in Kenya.
2. 1996: State two ways by which wind affects the growth of crops.
3. 1997: a) State two ways by which wind affects the growth of crops.  
b) Give two roles of micro-organisms in the soil that are beneficial to crops  
c) State three properties of soil that are influenced by its texture.
4. 1999: List down the four aspects of rainfall that affect agriculture.
5. 1999: Describe the environmental conditions that may lead to low crop yields.
6. 2000: Outline three effects of soil organisms which benefit crop growth.
7. 2001: State two causes of hard pan in a crop yield.
8. 2002: a) Name two processes of rock weathering.  
b) Differentiate between soil texture and soil structure.  
c) State three benefits of good soil structure in crop production.
9. 2003: a) List two aspects of light that influence crop growth.  
b) The diagram below shows an experiment set up using soil types G, H and J and observations made after 24 hours. Study the diagram and answer the questions that follow.

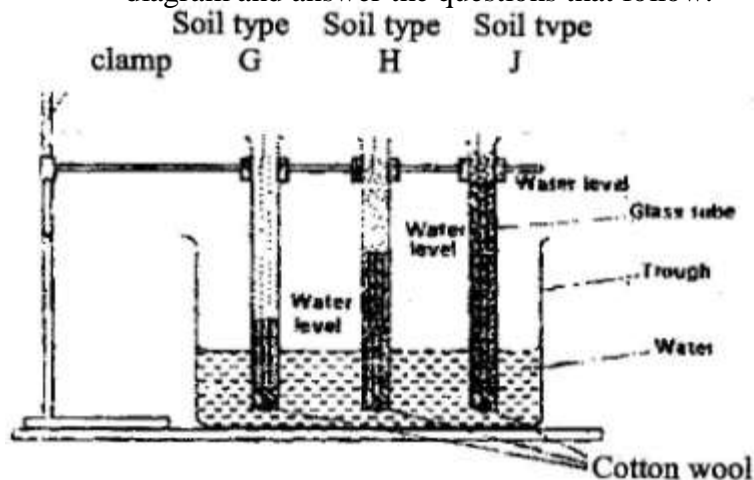

- i) What is the experiment represented above designed to study?
  - ii) Name the three soil types & H and J.
  - iii) What is the characteristic texture of soil types G and J?
  - iv) State how a farmer would improve the structure of soil type G.
10. 2004: a) Give 3 reasons why soil is important to crops.  
 b) State two benefits of optimum soil temperature in crop production.  
 c) Give 3 factors of soil that influence soil productivity.
11. 2004: Give three reasons why soil is important to crops.
12. 2004: a) Give four reasons why a well drained soil is suitable for crop production.  
 b) State two benefits of optimum soil temperature in crop production.  
 c) Give three soil factors that influence soil productivity.
13. 2005: State three advantages of adding organic matter to sandy soil.
14. 2005: a) State two roles of good soil aeration in crop growth.  
 b) Give two roles of micro-organisms in the soil that are beneficial to crops.  
 c) State three properties of soil that are influenced by its texture.

**FARM TOOLS AND MACHINERY**

1. 1995: Give one use of each of the following hammers;  
 i) Ball pein hammer    ii) Sledge hammer  
 State two maintenance practices that should be carried out on a wheelbarrow.
2. 1996 The diagram labeled N I, N II, N III below represent some tools used in farms.



N I



N II



N III

- i) What functional advantage does the tool labeled N II have over the tool labeled N III?
- ii) What is the function of tool labeled N I
- iii) Give the maintenance practice of N I

3. Study the photographs below carefully and answer the questions that follows:

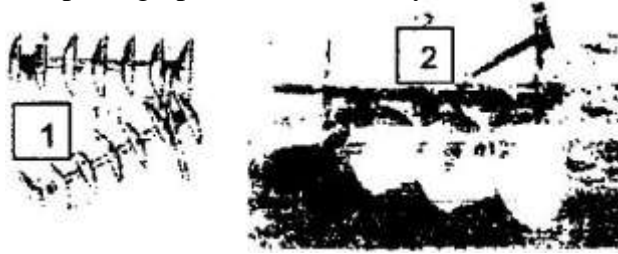

- a) i) Identify 1-----  
2-----
  - ii) Give the land preparation stage when 2 is used
  - b) i) Which of the tools is suited for a field with roots, trash and other obstacles?
  - ii) Give a reason for your answer in b(i)
4. 1996: State one use of each of the following tools;
    - (i) Spoke shave
    - (ii) Plumb bob
  5. 1997: Name two tools used for cutting galvanized iron pipes.
  6. 1998: State four maintenance requirements of a jack plane.
  7. 1998: List four tools used for laying concrete blocks when constructing a wall.
  8. 1999:
    - a) What is the difference between a tenon saw and a crosscut saw?
    - b) What safety measure should be taken when using a crosscut saw?
    - c) Give three maintenance practices that should be carried out on crosscut saws.
  9. 2000: Give the factor, that are considered when selecting a garden tool for primary cultivation.
  - 10: 2000
    - (a) State one use of each of the following tools, (i) sickle  
ii) Secateurs.
    - b) Give two reasons for proper maintenance of farm implements.
    - c) State three factors that should be considered when selecting gardener tools for primary cultivation.
  12. 2001: L, M, N and O are diagrams of farm tools. Study them and answer the questions that follow.

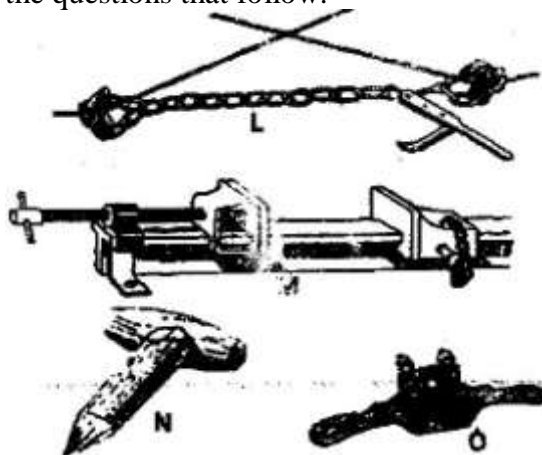

- i) Identify the farm tools; L, M, N and O. (ii) State the use of each tool L, M, N and O.

13. 2001: List the tool used for each of the following
- Tightening barbed wires during fencing,
  - Smoothening concrete floors during plastering.
  - Administration of liquid medicine to livestock through the mouth.
  - Processing butter-----
14. 2003: List five tools used when constructing a wooden fence.
15. 2003: a) Diagrams M, N, P and Q represents some farm tools.

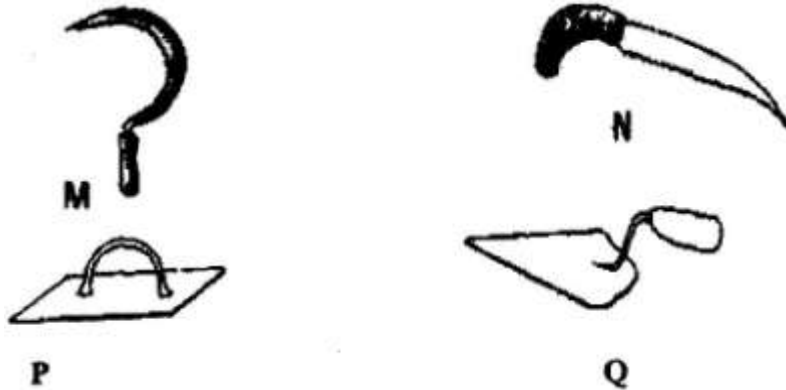

- Identify the tools; M,N,P and Q.
  - Give the use of each of the tools named above.
  - State two maintenance practices that should be carried out on tool M.
- (b) The diagram below shows a farm equipment. Study it and answer the questions that follow.

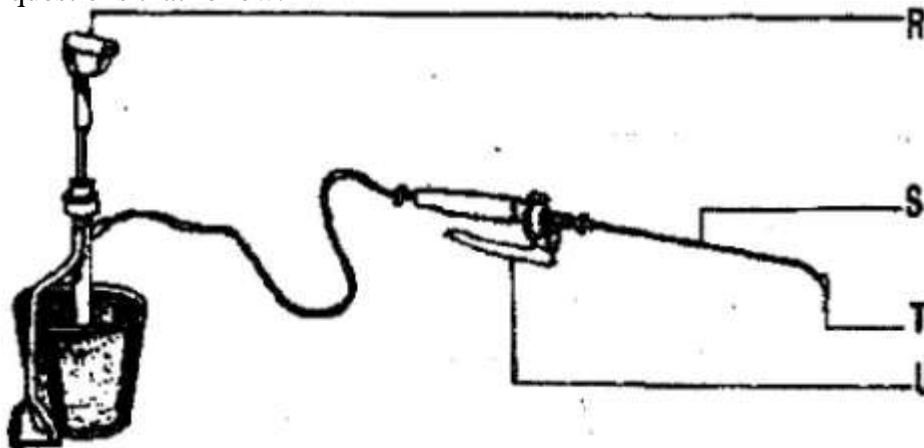

- Identify the equipment.
- Name the parts labeled R, S, T and U.

### CROP PRODUCTION – LAND PREPARATION

#### **K.C.S.E PAST PAPERS**

- 1994: State 4 reasons for primary cultivation.
- 1997: State four reasons for primary cultivation.
- 1999: State four factors which determine the depth of ploughing.
- 2000: (a) Give two reasons why the use of fire should be discouraged in clearing land during seedbed preparation.

- b) Give two reasons for secondary cultivation.
- c) State two benefits of minimum tillage in crop production.
- 4. 2000: List four implements used to carry out secondary cultivation
- 5. 2001: State two causes of hard pans in a crop field.
- 6. 2001: Give the maintenance practices of a disc plough.
- 7. 2002: State reasons why use of fire in clearing land is discouraged.
- 8. 2003: Outline the main reasons for secondary tillage.
- 9. 2004: State the main benefits of minimum tillage
- 10. 2005: a) State one condition under which a farmer would prefer to use an ox-cart instead of tractor – drawn trailer.
- b) Give three maintenance practices carried on an ox – plough.
- 11. 2004: Give four farming practices that may help in achieving minimum tillage.

### **WATER SUPPLY AND IRRIGATION**

#### **K.C.S.E PAST PAPERS**

- 1. 1994: Give the main methods of conveying water from place to place.
- 2. 1995: State two methods of storing water on a farm.
- 3. 1995: State two ways of overcoming the problem of water logging in crop production.
- 4. 1996: State four methods of treating water for domestic use.
- 5. 1997: (a) Give two ways of conserving water for livestock use.
- 6. State two means by which water can be conveyed from the place of Storage to where it is needed on the farm.
- 7. 1998: Name four types of water pumps which can be used on the farm.
- 8. 1998: List two features of plastic pipes a farmer should consider before buying the pipes.
- 9. 1998: a) State three factors to be considered before deciding on irrigation in crop production.
- b) State three advantages of overhead irrigation compared to surface irrigation.
- 10. 1998: Give four features of plastic pipes a farmer should consider before buying the pipes.
- 11. 1998: Name four types of water pumps which can be used on a farm.
- 12. 1998: Which of these factors would you consider in deciding on irrigation in crop production.
- 13. 2000: In what way is water useful for agriculture activities?
- 14. 2000: a) Explain the reasons for treating water on the farm.
- b) State the uses of water in the farm.
- c) Describe the process involved in water treatment using a chemical treatment system.
- 15. 2001: Give two factors that influence the quantity of water used in the farm.
- 16. 2001: State three farming activities which may cause pollution to water sources.
- 17. 2002: State three advantages of crop irrigation in a farm.

18. 2003: Study the illustration below carefully and answer the questions which follow.

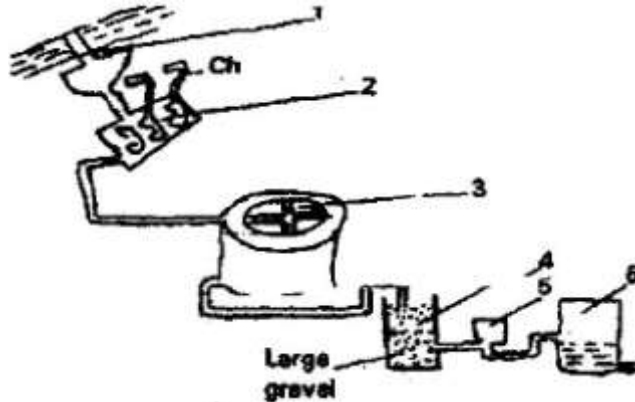

- a) Identify the illustration  
 b) Explain part 1 -6
19. 2003: Outline two routine maintenance practices carried out on water storage tanks.
20. 2003: List three types of surface irrigation in crop production.
21. 2003: List four methods used to drain farm land.
22. 2004: a) List three surface water sources found in a farm.  
 b) Give two reasons for treating water before use in a farm.
23. 2004: Give the reasons why water treatment is important.

### SOIL FERTILITY – ORGANIC MANURES

#### **K.C.S.E PAST PAPERS.**

1. 1995: How is green manuring carried out on a farm?  
 1995: (a) Give four reasons why it is advantageous to use farm yard manure instead of straight fertilizer.  
 (b) State four factors that determine the quality of farm yard manure.
2. 1998: State four ways by which plant nutrients may be lost from the soil.
3. Outline the various benefits of F. Y. M in the farm.
4. 1999: a) Define soil fertility  
 b) List the major characteristics of a fertile soil.
5. The diagram below is a presentation of a cross section through a compost heap. Study it and answer the questions which follow.

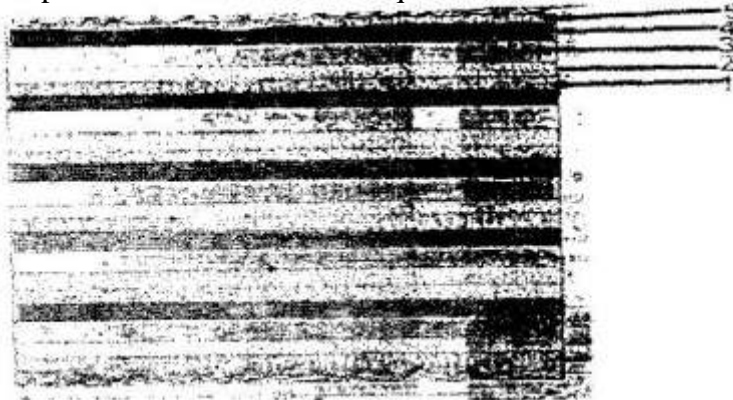

- a) i) Name the parts labeled 1 –  
Give the importance of 5, 4, 3
- b) Why is it advisable that
  - i) A long sharp pointed stick driven into the file at an angle.
  - ii) Compost pits be preferably alone in more drier area / weather.
- 9. 1999: Give four ways by which soil loses its fertility
- 10. 2000: State four characteristics that make a crop suitable for green manuring.
- 11. 2002: State three factors that determine the quality of compost manure.
- 12. 2003: State four characteristics of a fertile soil.
- 13. 2003: Name three farming practices which may lead to soil erosion.
- 14. 2005: State three factors which should be considered when sitting a compost heap.
- 15. 2005: State three advantages of adding organic matter to sandy soil.

### **LIVESTOCK PRODUCTION – (COMMON BREEDS)**

#### **K.C.S.E PAST PAPERS**

- 2. 1996: i) Name the breed of camel that is used for provision of quicker mode of transport and is & better adapted for arid conditions.
- ii) Give two reasons why this species of camel is well adapted to North par of Kenya.
- 3. 1998: i) Give two reasons why jersey breeds is better suited for marginal areas than Friesians breed.
- 3. 1999: Name the major characteristics of indigenous cattle breeds.
- 4. 1999: Give the major features of exotic beef breeds
- 1. 2000: Name the exotic cattle with
  - i) Highest butter fat content
  - ii) Lowest butter fat content
- 5. 2001: State two characteristics of goats that make them adaptable to arid areas of Kenya.
- 6. 2001: Give three ways used to improve & production in indigenous cattle.

### **AGRICULTURE ECONOMICS – BASIC CONCEPTS AND FARM RECORDS**

#### **KCSE PAST PAPERS**

- 1. 1994: List any four types of records a farmer should keep.
- 2. 2001: State four reasons for keeping health records in livestock production
- 3. 2005: State the conditions under which the opportunity cost is Zero in a farming enterprise.

### **SOIL FERTILITY II – INORGANIC FERTILIZERS**

#### **KCSE PAST PAPERS**

- 1. 1995/2001: State four characteristics of Nitrogenous fertilizers (2mks)
- 2. 1996: Calculate the amount of K<sub>2</sub>O contained in 400kg of a compound fertilizer 25:10:5. (2mks)

3. 1996: State four functions of Potassium in plant growth. (2mks)
4. Give two symptoms of potassium deficiency in crops ( 2mks)
5. 1998: State four ways by which plant nutrients may be lost from the soil (2mks)
6. 2001 a) State three functions of nitrogen in crops (2mks)  
b) State two symptoms of nitrogen deficiency in a growing maize crop (2mks)
7. 2003: State four effects of excessive application of Nitrogenous fertilizers on crop growth. (2mks)
8. 2004: Give two functions of sulphur in crops (2mks)
9. 2004: Give four deficiency symptoms of phosphorous in crops. (2mks)
10. 2005: List four ways of applying fertilizers in crops (2mks)
11. 2005: a) Differentiate between macro – nutrients and mirco – nutrients (2mks)  
b) State four functions of Calcium in plant growth and development (2mks)

### **CROP PRODUCTION II – PLANTING**

#### **KCSE PAST PAPERS.**

1. 1995: State four benefits of using vegetative propagation in orange production.(2mks)
2. 1995: (a) Give two advantages of growing cereal crops in rows instead of broadcasting.(2mks)  
(b) Give two reasons for planting crops at correct spacing (2mks)  
(c) Give two factors that determine the depth at which seeds should be planted. (2mks)
3. 1996: State any four factors that determine the spacing of a crop (2mks)
4. 1997: Give two reasons for sowing annual crops early in the planting season.(2mks)
5. 1997: Why should legume seeds be inoculated before planting (1mks)
6. 1997: State two benefits a farmer would get by having the correct plant population in the production of annual crops. (2mks)
7. 1998: State four factors that influence spacing when planting a pure stand maize. (2mk)
8. 1998: Give two factors that would influence the time of planting beans (1mk)
9. 1999: Give four reasons for seed selection in crop production. (2mks)
10. 1999: State six factors that influence the spacing of an annual crop. (2mks)
11. 2000: Give four advantages of under sowing in pasture production. (2mks)
12. 2000: (a) Give two harmful effects of high population density in a maize crop growth for grain production (2mks)  
(b) Calculate the plant population per hectares of a maize crop planted at a spacing of 100cm x 50cm. Show your working (2mks)
13. 2002: Name two crop production practices carried after planting to achieve optimum plant population. (1mk)
14. 2002: State five qualities of the mother plant which should be considered when selecting vegetative materials for planting. (2mks)



15. 2002: State four factors that determine the time of planting of a crop. (2mks)
16. 2002: Give four disadvantages of planting seed using broadcasting method. (2mks)
17. 2004: List four factors that determine (2mks)
18. 2005: Give six reasons for timely planting of annual crops. (3mks)

### **CROP PRODUCTION-NURSERY PRACTICES**

#### **KCSE PAST PAPERS**

- 1996/2005: Give a reason for carrying out each of the following practices in a tomato nursery. (2mks)
- (i) Pricking out (ii) Hardening off.
- 1997: Give two activities carried out during hardening off tomato seedlings (2mks)
- 1998: Give two characteristics of a good root stock for grafting. (1mk)

### **CROP PRODUCTION (IV) – FIELD PRACTICES**

#### **KCSE PAST PAPERS**

1. 1997/2005: State four reasons for pruning fruit crops (2mks)
2. 1998: Give two reasons for drying grains before storage. (2mks)
3. 1999: (a) Why is training done in some crops. (1mk)  
(b) Name two crops, which require training.
5. 1999: State two factors that determine the stage at which a grain crop is ready for harvesting (1mk)
6. 1999: State four benefits of using organic matter for mulching, sounds (2mks)
7. 2000: State two ways in which inorganic mulch helps to conserve moisture in the soil (1mk)
8. 2001: (a) What is crop rotation? (1mk)  
(b) State three advantages of crop rotation. (1mk)  
(c) State three factors considered when designing a crop rotation programme (2mks)

### **CROP PRODUCTION (V) – VEGETABLES**

#### **KCSE PAST PAPERS**

1. 1996/2005: (a) Give one cause of blossom end rot in tomatoes  
(b) State two methods of controlling blossom end rot in tomatoes (2mks)
2. 1996/2005: State four factors to consider when grading tomatoes for fresh market.

### **LIVESTOCK HEALTH – INTRODUCTION**

#### **KCSE PAST PAPERS**

1. 1996/1997: (a) State three advantages of keeping a herd of dairy cattle health. (3mks)
2. 1997: (a) State two reasons for maintaining livestock in good health. (2mks)

- (b) Name two noticeable diseases in cattle. (2mks)
3. 1999: state two ways by which proper feeding contribute to disease control in livestock. (1mk)
  4. 2000: Explain measures used to control livestock diseases. (12 marks)
  5. 2002: Give four ways in which diseases can spread can spread from one animal to the other within the farm.

### LIVE STOCK HEALTH – PARASITES

#### KCSE PAST PAPERS

1. 1995: (a) Which livestock disease is transmitted by each of the following ticks? (2mks)
  - (i) Blue tick (*Boophilous decoloratus*)
  - (ii) Brown ear tick (*Rhipicephalous appendicula tus*)
 (b) How many hosts does the red-legged tick (*Rhipicephalous averts*) require to complete its life cycle? (1mk)
2. 1998: (a) State four signs of infestation by external parasites in livestock? (2mks)
3. (a) State four signs of infestation by external parasites in livestock? (2mks)
 (b) Name the intermediate host for each of the following internal parasites. (2mks)
 

Tape worm (*Taenia solium*) (ii) Liver fluke (*Fasciola hepatica*)
4. 200: describe the life cycle of a three- host tick. (8mks)
5. 2003: State four non-chemical methods of controlling ticks in cattle. (2mks)
6. 2004: Give four measures that should be taken to control tapeworms on the farm. (2mks)

### LIVE STOCK PRODUCTION (II) – NUTRITION

#### KCSE PAST PAPERS

1. 1995/2002: What is a production ration as used in animal nutrition? (1mk)
2. 1995: Name two groups into which vitamins are classified. (1 mk)
3. 1996: State 3 factors that influence the amount of water intake by a farm Animal. (1<sup>1</sup>/<sub>2</sub> mks)
4. 1996: (a) Differentiate between a roughage and a concentrate feed in animal nutrition. (2mks)
 (b) State three ways in which a production ration may be utilized by cattle. (3 mks)
5. 1998: Give four characteristics of a livestock roughage feedstuff.
6. 1998: Outline four functions of proteins in the body of an animal. (2mks)
7. 1999/2002: Outline four factors that determine the nutritional requirements in cattle (2mks)
8. 2000: Give 4 functions of calcium in dairy cow. (2mks)
9. 2001: State four factors that are considered when formulating a livestock ration (2 marks)
10. 2002: (a) Explain the term “production ration” as used in livestock productions. (1mk)
 (b) State four factor which determine the amount of feed an animal

- can consume. (4mks)
11. 2004. State three reasons for feeding livestock. (1½mks)

### **LIVE STOCK PRODUCTION (III) - SELECTION AND BREEDING**

#### **KCSE PAST PAPERS.**

1. 1994: (a) How does crossbreeding improve livestock production.
2. 1994: State six signs that are likely to be observed when a cow is on heat
3. 1996: State four disadvantages of natural mating as a method of breeding in dairy cattle management.
4. 1997: Define the term out crossing in animal breeding.
5. The diagram below shows the reproductive system of a cow. Study it carefully and answer the questions that follow.



- a)
    - i) Name the parts labeled A B and C.
    - ii) State the function of each of the parts labeled a and b
  - b)
    - (i) Give two methods of mating in cattle
    - (ii) How long is the oestrus cycle in cattle?
6. 1998: Explain the term hybrid vigour as used in livestock production.
  7. 1999: Describe the factors a farmer should consider when selecting a young female pig (Gilt) for breeding.
  8. 2003:
    - (a) Define the following terms as used in livestock breeding.
      - (i) Inbreeding
      - (ii) Out crossing
    - (b) Outline three disadvantages of artificial insemination in cattle management
    - (c) State three desirable characteristics to be considered when selecting a heifer for milk production.

### **LIVESTOCK PRODUCTION (IV) – REARING PRACTICES**

#### **KCSE PAST PAPERS**

1. **1994:** Name two kinds of livestock which can be castrated using a rubber ring.
2. **1994:** Give four reasons why bees may swarm from a hive.

3. **1996:** Below is a diagram of a sheep with some parts labeled A, B, and C. Study the diagram and answer the questions that follow.

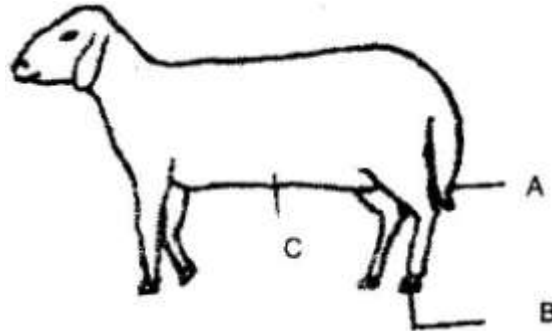

- (i) What operation is usually carried out on the part labeled A during a sheep's early stages of life?
- (ii) Why is it necessary to carry out the operation in (i) above?
- (iii) At what stage of sheep should the operation in (i) above be carried out?
- (iv) Give two methods of carrying out the operation in (i) above,
- (v) Which operation is usually carried out on part labeled B
- (vi) What problem would occur if the operation in (V) above is not carried out?
- (vii) How should the sheep be held when shearing wool around part labeled C?
4. **1998:** Why should smoke be used during harvesting of honey?
5. **1998:** state four reasons for culling breeding sows.
6. **1998:** (a) Define the term colostrums.  
(c) Explain three qualities that make colostrums suitable for newly born calves.  
(d) Give three methods of feeding colostrums to a newly born calf.
6. **1999:** Give six signs a cow would show just before parturition.
7. **2000:** State four reasons for castrating male piglets.
8. **2000:** Give two qualities of creep feed that makes it suitable for piglets.
9. **2000:** State two reasons why it is necessary to place sugar syrup close to a beehive.
10. **2000:** State four routine management practices that should be carried out on a lactating ewe.
11. **2001:** State six management practices in fish rearing.
12. **2002:** Give five signs, which indicate that a sow is about to farrow.
13. **2002:** State four conditions which would make it necessary to feed bees.
14. **2003:** State four management practices that should be carried out during the mating season in sheep.
15. **2005:** Name four species of fresh water fish reared in Kenya.

### FARM STRUCTURES.

1. **1994:** The diagram below represents a calf pen. Study it to answer the questions that follow.

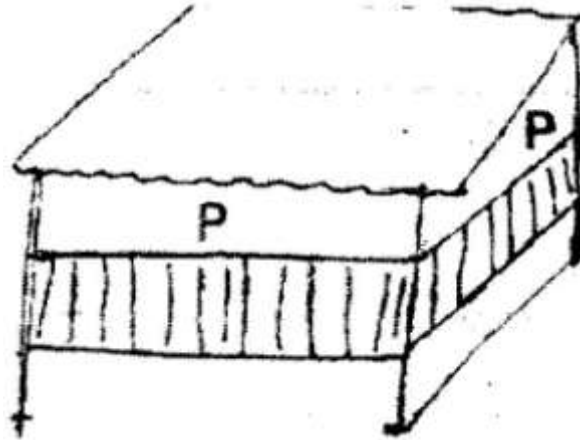

- (i) How high should the floor be above the ground level?  
(ii) Why should the floor of the calf pen be raised?  
(iii) Why should the parts of the pen marked p be open?  
(iv) State three factors that should be considered in sitting a calf pen?
2. **1995:** State two advantages of using wood in the construction of farm buildings
3. **1995:** Describe the construction of a rabbit hutch under the following sub-headings.
4. **1996:** Give two reasons for treating timber to be used in construction of farm buildings.
5. **1996:** State one advantage and one disadvantage of using barbed wire instead of plain wire for fencing paddocks.
6. **1996:** State two functions of ventilation in an animal house.
7. **1996:** a) One of the recommended ratio of mixing ingredients for making Concrete block is 1:3:4, Name ingredients represented by the numbers 1, 3 and 4 in the mixture.  
b) If stronger concrete blocks were to be made, name the ingredient that would be increased.  
c) State three properties of concrete that make it suitable for constructing farm buildings.  
d) In addition to concrete, name three other materials that would be required to construct the floor of milking shed.
8. **1997:** State four features of a good maize granary.
9. **1998:** State two reasons why maintenance of farm structures is important.
10. **1998:** a) State any four factors that would influence the sitting of a calf pen.  
b) State four factors to consider when selecting materials for constructing a calf pen.  
c) Give four maintenance practices that should be carried out on a permanent calf pen.
11. **1999:** Give two practices, other than use of preservatives, that can be carried out on wooden fencing posts to make them last long.
12. **1999:** State six features of an ideal calf pen.

13. **1999:** Outline any four maintenance practices that should be carried out in a deep litter poultry house.
14. **2001:** Give two advantages of concrete blocks over timber as building materials.
15. **2001:**
  - a) State the uses of fences in farms.
  - b) What factors would be considered when sitting a farm structures.
16. **2002:** a) State four advantages of a hedge in a farm.
17. **2003:** State four advantages of using a Kenya Top Bar Hive ove log hive.
18. **2003:** Outline two routine maintenance practices carried out on water tanks.
19. **2004:**
  - a) Explain the uses of various hand tools in the construction a Kenya Top Bar Hive
  - b) Describe the procedure of erecting wooden posts for fencing.
20. **2005:** State three disadvantages of using steel in construction of farm buildings.

### SOIL AND WATER CONSERVATION

#### KCSE PAST PAPERS

1. **1995:** Give one way through which check dams control soil erosion.
2. **1997:** State two ways by which trees help in soil conservation.
3. **1997:** State two reasons for carrying out soil conservation in a farm.
4. **1998:** State two ways by which grass cover help to conserve soil.
5. **2003:** State two ways by which inorganic mulch help to conserve water in the Soil.
6. **2004:** Define the terms;
  - a) Forestation
  - b) Re-a forestation
7. **2005:** Outline three factors, which may influence soil erosion.

### WEEDS AND WEED CONTROL

#### KCSE PAST PAPERS

1. **1998:** State four reasons why timely weed control is advisable in crop production.
2. **2000:** Give four ways of controlling weeds in a maize field. (2mks)
3. **2000:** PP2: Diagram & and H show weeds.
  - i) Identify the weeds. (2mks)
  - ii) State the economic importance of the weed shown in diagram G (2mks)
  - iii) Why is it difficult to control weed in diagram G? (1mk)
4. **2001:** State six disadvantages of weeds in crop production (3mks)
5. **2004:** (i) State four factors that contribute to the competitive ability of weeds. (2mks)

6. **2004:** The diagram below represents a weed.



- i) Identify the weed (1/2 mrks)
- ii) Classify the weed according to its life span. (1/2 mark)
- iii) State one harmful effect of the weed to livestock. (1mk)

### **AGRICULTURE ECONOMICS (II)- LAND TENURE AND REFORMS**

#### **KCSE PAST PAPERS**

1. **1997:** State four disadvantages of communal land tenure system.
2. **1999:** Give two ways in which land consolidation helps to improve farm management.
3. **2003:** State four objectives of land settlement which have been undertaken in Kenya
4. **2005:** Give two forms of collective land tenure system in

### **CROP PESTS AND DISEASES**

#### **KCSE PAST PAPERS**

1. **1994:** PP2  
Below is a diagram of a bird labeled A. Which is a crop pest?



- i) Identify the pest

- ii) State two ways by which the bird causes loss in crops.
  - iii) State four methods, which are used to control the pests.
2. 1995: The diagram labeled D below shows a Kale crop invested by a pest

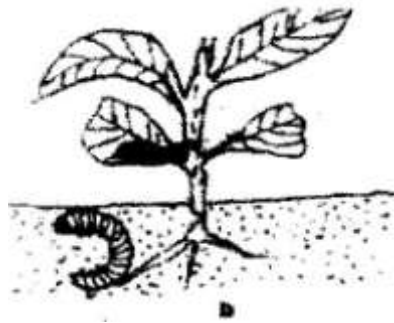

- i) Identify the pest.
  - ii) What damage does the pest cause the crop?
  - iii) State two methods of controlling the pest
3. 1995: Give two methods of controlling the pest?
4. 1995: State two cultural methods of controlling bollworms in a crop of cotton.
5. 1996: Give two ways of controlling bacteria blight in cotton.
6. 1998/1999: State four factors that affect the effectiveness of a pesticide.
7. 1999: a) State two feeding habits of field insect pests.  
b) State two cultural methods of pest control in stored grains.
8. 1999: Explain how various practices carried out in the field help to control crop diseases.
9. 2003: State three cultural ways of controlling nematodes in a field of bananas.
10. 2003: a) Define the term "Economic Injury Level" of a crop.  
b) Give two ways by which pesticides kills crop pests.  
c) State four disadvantages of chemical pest control in crop production.
11. 2004: Give three harmful effects of pests in crop production
12. 2005: State two cultural methods in controlling bollworms in a tomato crop.
13. 2005: Give two possible causes of swelling on the roots of bean plants.

### CROP PRODUCTION (VI) FIELD PRACTICES (II)

#### KCSE PAST PAPERS.

1. 1994: Name two field pests and two diseases of millet.
2. 1996: Why is it advisable to apply a straight nitrogenous fertilizer to a crop of maize at a height of 30 – 45cm.
3. 1996: Which disease causes a mass of dark spores on the flowering parts of maize?
4. 1996: State any four non – chemical methods of controlling storages pests in a maize granary.
5. 1996: List four insect pests of maize in storage.



6. **1996:** PP2 The diagram below labeled G, H, J and K shows different stages of cotton fruit.



- i) Rearrange the label G, H, J, and K to show the correct sequence in which the cotton fruit develops.
  - ii) What would be the effect of attack by cotton boll worms at the stage labeled K?
  - iii) State two conditions that should be observed when harvesting to ensure that cotton picked is of high quality.
  - iv) Name the two products which are obtained after processing cotton.
7. **1997:** State four practices used to control maize streak in the field.
8. **1998:** i) State two cultural methods of controlling pests in an established field of sorghum.
- ii) List any four insect pests that attack maize in the field.
9. **2000:** Give four ways of controlling weeds in a field of maize.
10. **2000:** Give four control measures of maize streak virus.

### FORAGE CROPS

#### **KCSE PAST PAPERS.**

- 1997 / 1995:** State two advantages of establishing a mixed grass legume pasture instead of planting a pure grass pasture.
2. **1996:** Give two disadvantages of overstocking in cattle production.
3. **1997:** State two roles of additives in silage making.
4. **1997:** a) Define the following term, (i) Under sowing (ii) Over sowing  
b) State three methods of controlling weeds in a pure grass pasture.  
c) Give three benefits of top dressing in the management of grass pastures.
5. **1998:** State four ways by which a farmer can make efficient use of a pasture crop.
6. **1999 / 2004:** Give four factors that determined the nutrient content of hay.
7. **2000:** State four advantages of under sowing in pasture production
8. **2003:** Describe field production of Napier elephant grass under the following sub-headings.
- i) Seedbed preparation

- ii) Planting
  - iii) Fertilizer application
  - iv) Weed control
  - v) Utilization
9. **2004:** (a) List three pasture legumes grown in medium altitude zones.  
(b) Give three advantages of rotational grazing.  
(c) State three ways by which overheating can be prevented in the process of making silage.
  10. **2005:** State two advantages of proper stocking pasture management.
  11. **2005:** Explain the following terms as used in pasture establishment.
    - a) Seed Inoculation
    - b) Over sowing

### **LIVE STOCK HEALTH (III) – LIVESTOCK DISEASES**

#### **KCSE PAST PAPERS.**

1. **1994:** List six routes through which pathogens can enter the body of an animal.
2. **1995:** State two methods of controlling rinder pest disease in cattle.
3. **1994/1996:** Give four symptoms of Newcastle disease in poultry.
4. **1996:** State four predisposing factors to the occurrence of mastitis in dairy cattle.
5. **1996:** State any three symptoms of mastitis in dairy cattle.
6. **1997:** Name two notifiable diseases in cattle.
7. **1996/2004:** State two measures that should be taken to prevent an outbreak of Newcastle disease in poultry.
8. **1997: PP2:** The diagram below shows the head of a chicken having symptoms of a poultry disease.
  - i) Identify the disease
  - ii) Give two reasons why the disease is of economic importance to the farmer.
  - iii) State any two methods of controlling the disease.
9. **1999:** State four symptoms of foot rot in sheep.
10. **2009:** Name the causal agents for each of the following disease,
  - i) Coccidiosis
  - ii) Black quarter
11. **2000:** i) State two predisposing factors of foot rot in sheep.  
ii) Give three symptoms of anaplasmosis disease.
12. **2000:** Explain measures used to control livestock diseases. (12mks)
13. **2001:** Give two signs that would indicate that a cow has died of anthrax.
14. **2001:** a) Name the causal organism of brucellosis in cows (1mks)  
b) Give two symptoms of brucellosis in cows.  
c) State four measures that should be taken to control brucellosis in cattle.
15. **2002:** Give three methods of controlling rinderpest in cattle.
16. **2004:** Mention four symptoms of East Coast Fever in cattle.
17. **2005:** a) State the cause of milk fever in dairy cows. (1mks)  
b) Give four symptoms of milk fever in dairy cows.  
c) State two methods of controlling milk fever.

## LIVESTOCK PRODUCTION – POULTRY

### KCSE PAST PAPERS

1. **1995:** Give three methods of controlling cannibalism in a flock of layers in deep litter system.
2. **1995:** List four factors that should be considered when grading eggs for marketing.
3. **1998:** a) Describe the artificial rearing of layer chicks from day old up to the end of brooding.  
b) Describe the characteristics of a poor layer, which should be considered during culling
4. **1999:** Outline any four maintenance practices, which should be carried out in a deep litter poultry house. (2mks)
5. **2000:** Give four conditions that reduce the quality of eggs for hatching. (2mks)
6. **2001:** Give four measures that can control egg eating by hens in a deep litter system (2mks)
7. **2002:** a) State four observations on the behaviour of chicks which would indicate that the temperature of a brooder is too high. (4mks)  
b) Give four advantages of deep litter system of poultry keeping. (4mks)
8. **2005:** List six qualities of eggs suitable for incubation (3mks)
9. **2005:** Describe the steps to be taken in maintaining hygiene in a deep litter poultry house. (5mks)

## LIVESTOCK PRODUCTION (VI) – CATTLE

### KCSE PAST PAPERS.

1. **1995:** (a) The diagram below is a cross section of part of a cows adder

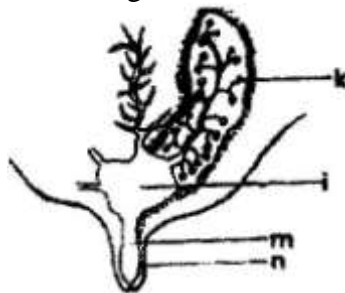

- Label on the diagram the parts marked k, l, m and n. (2mks)
- (b) i) What is milk let down? (1mk)  
ii) Which hormone stimulates milk let down.(1mk)
  - (c) State three practices which are carried out to control mastitis in lactating cows.
2. **1995:** Describe the management of a dairy heifer calf from birth until it is mature for first service. (20mks)
  3. **1997:** a) Name any two characteristics of good quality whole milk. (1mk)  
b) State three advantages of artificial calf rearing. (3mks)
  4. **1998:** State four qualities of clean milk. (2mks)

- a) Define the term colostrums (1mk)
  - b) Explain three qualities that make colostrums suitable for newly born calves. (3mks)
  - c) Give two methods of feeding colostrums to a newly born calf. (1mk)
5. **1999:** State any six practices that would ensure clean milk production (3mks)
6. **2000:** State six marketing problems affecting dairy farming in Kenya. (3mks)
7. **2001:** Describe the management of a dairy calf using artificial rearing method from birth to weaning (20 mks)

### FARM POWER AND MACHINERY

#### KCSE PAST PAPERS

1. **1995:** (a) States four advantages of farm mechanization (2mks)
- (b) Give the functions of each of the following parts of a mould board plough. (4mks)
- (i) Mould board
  - (ii) Share
  - (iii) Frog
  - (iv) Landslide.
- (c) Give two daily maintenance practices that should be carried out on a mould board plough. (2mks)
2. **1995:** The diagram below is a tractor drawn implement hitched at the rear of the tractor.

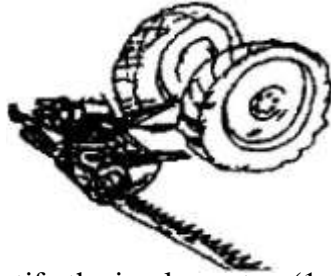

- (i) Identify the implement (1mk)
  - (ii) What is the method of power transmission for operating the implement? (1mk)
  - (iii) State three maintenance practices that should be carried out on the implement. (3mks)
3. **1996** a) Compare the use of an ox-drawn mould board plough with that of a tractor-drawn mould board plough. (9mks)
- b) Describe the maintenance practices that should be carried out on an ox-drawn mould board plough (6mks)
- c) What are the advantages and disadvantages of using tractor hire service farming instead of owning and using your own tractors. (5mks)
4. **1997** a) State two reasons of applying oil and grease on a rotary mower. (2mks)
- b) State four maintenance practices required on a rotary mower besides oiling and greasing. (2mks)
- c) State four factors that a farmer should consider before buying a tractor for use as the source of power on the farm. (2mks)

5. **1999** a) Give two uses of ox –drawn harrow (2mks)  
b) Give two maintenance practices of a ox-drawn tine harrow. (2mks)  
c) State two advantages of an ox- drawn harrow over tractor-drawn harrow. (2mks)
6. **2000:** Out line four maintenance practices of a disc harrow. (2mks)
7. **2001** a) State one method of increasing ploughing depth when using a disc plough. (1mk)  
b) State two reasons for maintaining a disc plough, (2mks)  
c) State three advantages of farm mechanization. (3mks)
8. **2003** a) State two functions of a coulter in a mould board plough. (2mks)  
b) Give three maintenance practices carried out on an Ox-drawn trailer. (3mks)
9. **2004** a) State two problems associated with tractor hire service that farmers encounter. (1mk)  
b) List four implements used to carry out secondary cultivation. (2mks)
10. **2005** a) State one condition under which a farmer would prefer to use an ox-cart instead of a tractor-drawn trailer.  
b) Give three maintenance practices carried out on an ox-plough., (3mks)

### **AGRICULTURE ECONOMIC III- PRODUCTION ECONOMICS**

1. **1995:** (a) State four ways of improving the labour productivity of farm labour. (2mks)  
(b) What is increasing returns in a production? (1m ark)  
(c) What are three classifications of farm credits according to the repayment periods? (1 ½ mks)
2. **1996:** a) Define the term opportunity cost as used in economics. (1mk)  
b) What is working capital in a farming situation (1mk)  
c) Define the term utility of a commodity as used in agriculture economics. (1 mk)
3. **1997:** (a) State any two sources of capital for farming  
(b) Explain the advantages of budgeting in farm business. (5mks)
4. **1998:** a) Explain the difference between fixed costs and variable costs in farming.  
b) Give four variable costs in the production of coffee in an established field of coffee. (2mks)  
c) Give 3 advantages of planning in a farm business. (3mks)
5. **1999:** Give two uses of gross margin analysis in farm business.

6. **1999:** a) Below is a graphical representation of The law of admonishing returns.

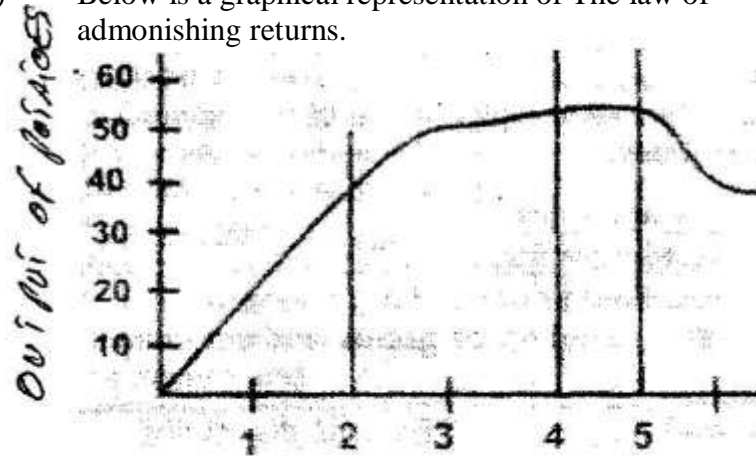

- a) Explain what happens in each of the Zones marked I, II and III in relation to output.(3mks)
- b) Which of the three is a rational zone of production? (1mks)
- c) State any three precautions a potatoes farmer would take to minimize risks in the production of potatoes. (2mks)
7. **2000:** a) State three ways of improving labour productivity in a farm.
- b) Give two changes that would indicate improvement of labour efficiency in farm. (2mks)
- c) State two ways of determining the rate of payment of casual labour in a farm. (3mks)
8. **2001:** a) State four factors that influence the supply of casual labour in a farm.(2mks)
- b) State six ways by which a farmer can risk and uncertainties.
- c) State six reasons why agriculture is important in Kenya economy.(3mks)
9. **2002:** State 2 reasons for choosing the right enterprise combination in farming business. (1mks)
10. **2003:** a) Give four examples of joint products in livestock production.
- b) List four variable inputs in poultry production.
- c) A farmer can combine dairy meal and home made in

Dairy meal (kg)	Home made feed (kg)	Marginal rate of substitution
1	48	O
2	39	V
3	32	7
4	27	W
5	23	4
6	21	X
7	20	1
8	19	y

- i) Given the above information, calculate the marginal rate of substitution and give values of V, W, X and X (4mks)

- ii) Given that the price of dairy meal is Ksh. 8.00 per kilogram and that of homemade feeds is Ksh. 2.00 per kilogram, calculate the least cost combination. (1 mks)
11. **2004:** a) Name three – product relationships in agriculture economics.  
 b) Explain the following terms as used in agriculture economics.  
 i) Production function  
 ii) Equi-marginal returns.
12. **2005:** Name five sources of agriculture credit in Kenya (1 ½ mks)
13. Give two examples in each case of the following costs incurred in the production of milk.  
 a) Variable costs (1mk)  
 b) Fixed costs (1mks)
14. **2005:** a) Differentiate between partial budget and complete budget. (2mks)  
 b) Explain how factors may adjust uncertain rules in farming business (2mks)

The cost of fertilizer is Kshs. 1500 per unit and the price of maize is Ksh. 1200 per bag.

- i) At what unit of fertilizer input should the farmer be advised to stop applying any more fertilizer to the maize.  
 ii) Give two reasons for your answer in b (i) above.  
 iii) Calculate the marginal return at the point of optimum production.

### AGRICULTURAL ECONOMICS

#### (FARM ACCOUNTS)

1. **1996:** a) List four types of financial books farmers should keep. (2mks)
- 1996:** State two uses of a balance sheet. (2 mks)
2. **1998:** Study the following information which was extracted from Mr. Rambo's farm record on 31 -12 – 95 and answer the question below.

	Kshs.
Loans payable to bank	300,000
Five milking cows	250,000
400 layers	80,000
20 goats	30,000
Debts payable to cooperative	20,000
Buildings and structures	600,000
Bonus payable to workers	19,000
Cattle feed in store	10,000
Animal drugs in store	4,000
Debts receivable	18,000
Breakages to repair	30,000
Cash at hand	20,000
Cash in bank	30,000
Spray equipment	12,000

Prepare a balance sheet for Rambo's farm using the information above 7 mks

3. **2001:** a) Explain the following terms as used in farm account.
- Cash account
  - Ledger
  - Balance sheet
  - Purchase order.
- Name two types of inventories used in farm accounts. (2mks)
4. **2002:** On 5 – 1- 2001 Tamu farm purchased on credit the following items from a K. F. A shop.
- 20 bags of dairy meal, 70kg each @ sh. 1,100 per bag.
  - 16 bags of bran, 70kg each @ sh. 700 per bag.
  - 18 bags of D.S.P fertilizer, 50kg each @ sh. 1,500 per bag.
  - 45 bags of seed maize, each 2kg @ Ksh. 300 per bag.
  - 8 shearing knives (medium size) @ sh. 300 per knife.
- Prepare the purchase order that Tamu farm made to K.F.A. (6mks)
  - Calculate the value of each item purchased and the total value of the order.(3mks)
5. **2004:** The following accounts information is from Mrs. Mbuta's farm for the year ended 31 – 12 – 2003.
- |                        |              |
|------------------------|--------------|
| Opening valuation      | Ksh. 6,000/= |
| Paid wages             | Ksh. 5000/=  |
| Bought equipment worth | Ksh. 8,000/= |
| Bought pig feeds worth | Ksh. 4,000/= |
| Sold mature pigs worth | Ksh. 7,000/= |
| Bought drugs worth     | Ksh. 3,200/= |
| Sold maize worth       | Ksh. 3,000/= |
| Closing valuation      | Ksh. 4,000/= |
- Using the information above, prepare a profit and loss account for Mrs. Mbuta's farm.
  - From the calculations in (i) above, state whether Mrs. Mbuta made a profit or a loss. (1mk)
6. **2005:** a) What is opening valuation as used in farm account? (1mks)
- State the use of each of the following financial documents (3mks)
    - Cash receipt
    - Purchase order.
    - Delivery note.

## AGRICULTURAL ECONOMICS

### (AGRICULTURAL MARKETING AND ORGANIZATION)

1. **1995:** a) What is the minimum number of people required to form a co-operative society? (1mks)
- State four factors that may influence the supply of a commodity in a market? (4mks)
  - State four problems that farmers are likely to face when marketing their produce. (4mks)
  - Name two marketing organizations for coffee in Kenya. (1mk)



2. **1996:** a) Differentiate between market and marketing? (2mks)  
b) What is an imperfect market? (1mk)  
c) How will the price of mangoes in the short run be affected if the quantity of mangoes supplied in a market is increased  
d) State any four problems a dairy farmer is likely to face in marketing milk. (2mks)
3. **1997:** a) State the law of demand. (1mk)  
b) State four factors that determine the demand of a commodity in a free market economy. (4mks)  
c) What is elasticity of demand for a commodity? (1mk)  
d) Explain the functions of agricultural marketing boards. (15 mks)
4. **1998:** a) Give four benefits a farmer would derive from being a member of a dairy co-operative society. (2mks)
5. **1999:** a) Explain the problems farmers face in marketing of agricultural produce. (9mks)  
b) Describe the various agencies and institutions involved in marketing of a agricultural produce. (5mks)
6. **2000:** a) State six factors that influence demand for a commodity in a market. (3mks)
7. **2003:** a) Given that at a price of Ksh.100 per bag, 20 bags of maize are demanded, but when the price changes to Ksh.800 per bag, 22 bags of are demanded. Calculate the elasticity of demand. Show your working. (3mks)
8. **2003:** a) Describe the functions of agricultural marketing (10mks)  
b) Explain the role of agricultural co-operatives in Kenya. (10mks)
9. **2004:** a) State six problems experienced by farmers in marketing agricultural produce. (3mks)

**K.C.S.E AGRICULTURE PAPER 1 2006**  
**SECTION A (30 marks)**

*Answer all the questions in this section in the spaces provided*

1. Differentiate between Olericulture and pomoculture as used in crop production ( 1 mk)
2. State three ways by which biological agents can enhance the process of soil formation ( 1 ½ mk)
3. State four advantages of drip irrigation ( 2 mks)
4. State four advantages of adding organic manure to a sandy soil ( 2 mks)
5. State two factors that would determine the amount of fertilizer to be top dressed to a crop in the field ( 1 mk)
6. State four advantages of applying lime as a measure of improving soil condition ( 2 mks)
7. Give four reasons for using certified seeds for planting ( 2 mks)
8. Give four reasons for planting crops at the correct spacing ( 2 mks)
9. State three effects of soil erosion ( 2 mks)
10. Name four methods used to control weeds in pastures ( 2 mks)
11. State two benefits of conserving forage crops ( 2 mks)
12. Mention four practices that should be carried out to maintain grass pasture ( 1 ½ mks)
13. Define the following terms as used in agriculture economics
  - (a) Gross domestic product (GDP) ( 1 ½ mks)
  - (b) Per capita income ( ½ mks)
14. What is profit maximization in agriculture economics? ( ½ marks)
15. State four benefits of budgeting to a farm manager ( 2 mks)
16. Give two reasons why farmers keep farm accounts
17. State activities carried out by young farmers club in Kenya ( 2 mks)
18. State four ways by which afforestation helps in land reclamation ( 2 mks)
19. State three advantages of multiple stem pruning over single stem pruning in coffee ( 1 ½ mks)

**SECTION B (20 mks)**

*Answer ALL the questions in this section in the spaces provided*

20. Two maize pests are shown in the diagram below. Study them and answer the questions that follow,

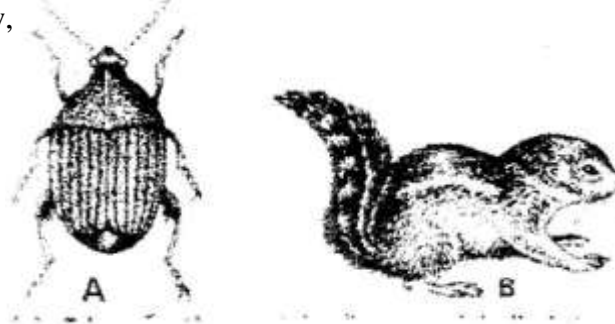

- (a) Identify the pests in the diagram labeled A and B ( 1 mk)
- (b) at what stage of maize production does each damage the crop?
- (c) Give one way of controlling each of the pests in the field

21 (a) state the law of diminishing returns in a production process

(b) Use the information on the table below to answer the questions that follow

Fertilizer input ( units)	Maize yield (bags)	Marginal productions (bags)
0	50	12
1	62	12
2	66	4
3	68	2
4	69	1
5	69	0

The cost of fertilizer is Kshs 1500 per unit and the price of maize is Kshs 1200 per bag.

- At what unit of fertilizer input should the farmer be advised to stop applying any more fertilizer to the maize? ( 1mk)
- Give a reason for your answer in (b) above
- Calculate the marginal return at the point of optimum production ( 1mk)

22. (a) Describe the procedure which should be followed in spraying a crop in tomatoes using a fungicide in powder form, water and a knapsack sprayer. ( 3 mks)

- Name one fungal disease of tomatoes that can be controlled using the above procedure. (1mks)
- State four safety measures that should be taken while spraying the crop with the fungicide. (2mks)

23. The diagram below shows a weed



- Identify the weed (1mk)
- State two reasons for controlling the weed. (2mks)
- Name two herbicides that can be used to control the weed in a field of maize (1mk)
- At what stage of growth of maize should the weed be controlled using a post emergence herbicide?

**SECTION C (40 MARKS)**

*Answer any TWO questions in this section in the spaces provided at the end of the section.*

24. Describe the establishment of kales under the following sub – headings:
- a) Nursery preparation
  - b) Establishment in the nursery
  - c) Management of seedlings in the nursery.
  - d) Transplanting of seedlings.
25. a) Outline the factors necessary for proper functioning of farmers' co-operative societies in Kenya. (5mks)
- b) Explain how farmers overcome risks and uncertainties in a farming business.
- c) Describe the steps farmers should follow when planning a farm business
26. a) List various methods of harvesting water in a farm
- b) Outline farming activities which may encourage soil erosion.
- c) Explain how various farming practices would help to conserve soil in a farm.

**K.C.S.E. 2006 PAPER 2**  
**SECTION A (30 MARKS)**

*Answer ALL the questions in this section in the spaces provided.*

1. Name a breed of sheep with a Lambing percentage of above 125 and whose fleece may be inferior due to black fibres. (1mk)
2. List two appropriate hand tools needed to finish off the handle of a fork-jembe. (1mk)
3. What is “cropping” in fish farming? (1mk)
4. State four functions of lubrication system in a tractor. (2mks)
5. Give four maintenance practices carried out on the water cooling system of a tractor. (2mks)
6. State reasons why a farmer would choose to use a disc plough rather than a mould board plough. (2mks)
7. State four construction features necessary in a fish pond. (2mks)
8. Give four ways in which disease causing organisms can gain access into a newly born calf (2mks)
9. State four ways of controlling tsetse flies. (2mks)
10. Give two predisposing factors of foot-rot in sheep. (1mk)
11. State four factors which should be considered when selecting dairy goats for breeding. (2mks)
12. Give four reasons why camels are suited to living in arid areas. (2mks)
13. Name two functions of the crop in the digestive system of chicken. (1mk)
14. State four methods of dehorning (2mks)
15. Mention six causes of stress to a flock of layers. (3mks)
16. State four functions of the worker bees in a bee colony. (2mks)
17. State four features of a good pig house. (2mks)

**SECTION B (20 MARKS)**

*Answer ALL the questions in this section in the spaces provided.*

18. (a) A diagram of a planter is shown below. Study it and answer the questions that follow.

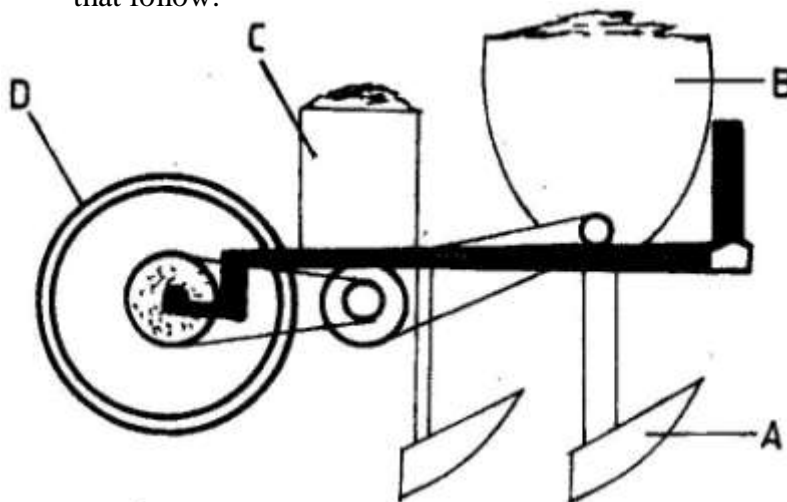

(i) Identify the parts labelled A, B, C, and D, (2mks)

- A \_\_\_\_\_
- B \_\_\_\_\_
- C \_\_\_\_\_
- D \_\_\_\_\_

(ii) State two maintenance practices carried out on the planter. (2mks)

b) Study the diagrams of workshop tools shown below



(i) Identify the tools labeled E and F (1mk)

- E \_\_\_\_\_
- F \_\_\_\_\_

(ii) What functional advantage does tool E have over tool F? (1mk)

19. The diagram below represents a calf pen. Study the diagram and answer the questions that follow.

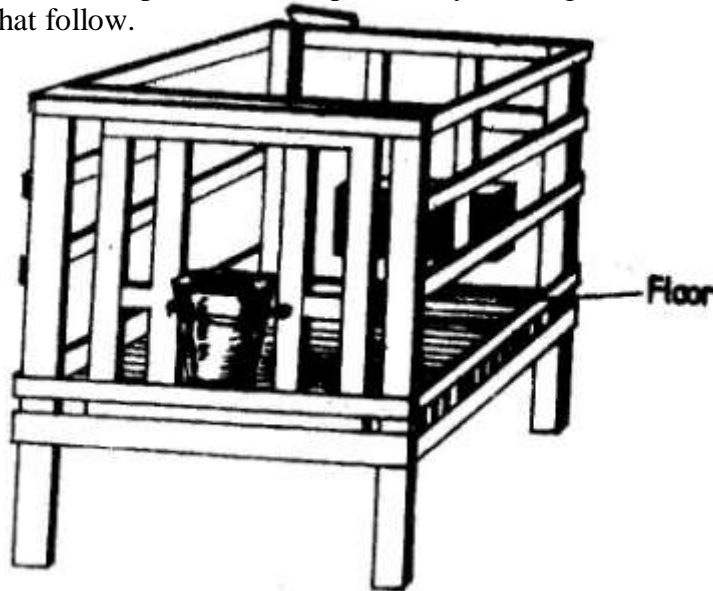

- (a) (i) Identify the type of floor. (½ mk)
- (ii) How high should the floor be raised above the ground level? (1mk)

- (b) (i) Give one reason for having the floor of the calf pen raised. (1mk)  
(ii) State three factors that should be considered in sitting the calf pen. (3mks)
20. (a) Define the term digestible Crude Protein (DCP) (½ mk)
- (b) A farmer wanted to prepare a 200kg of calf rearing ration containing 20% DCP. Using the Pears Square Method, calculate the amount of Maize containing 10% DCP and Sunflower containing 35% DCP the farmer would need to prepare the ration. (Show your work) (4mks)

21. A diagram of a cow is shown below. Study it and answer the questions that follow.

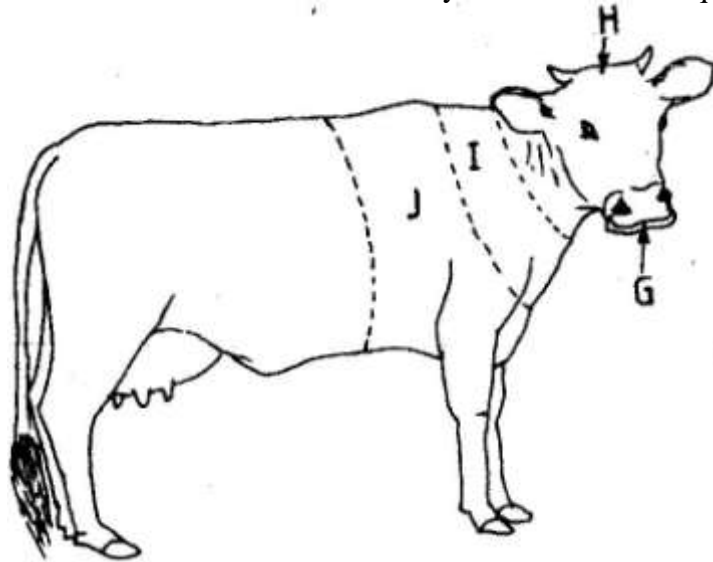

- (a) Name the parts labeled G, H, I and J.

G \_\_\_\_\_  
H \_\_\_\_\_  
I \_\_\_\_\_  
J \_\_\_\_\_

- (b) Name four parts of the animal preferred by a two host tick. (2mks)

**SECTION C (40 MARKS)**

*Answer any TWO questions in this section in the spaces provided at the end of the section.*

22. a) Outline the procedure followed when hand spraying cattle to ensure effective use of acaricides to control ticks. (10mks)
- b) Discuss Foot and Mouth disease under the following headings:
- (i) Casual organisms. (1mk)
  - (ii) Livestock species attacked. (2mks)
  - (iii) Symptoms of attack. (4mks)
  - (iv) Control measures. (3mks)
23. a) Describe the management practices that a farmer should carry out to improve milk production in a low yielding herd of dairy cattle.(15mks)
- b) Describe the management practices that would ensure maximum yield of fish in a fish pond. (5mks)
24. a) What are the advantages of farm mechanization? (6mks)
- b) Explain the differences between a two stroke and a four stroke cycle engine. (6mks)
- c) Outline the daily maintenance practices that should be carried out on a farm tractor (8mks)



## K.C.S.E 2007 AGRICULTURE PAPER 1

### SECTION A [30 MARKS]

Answer **ALL** the questions in this section in the spaces provided.

1. Give **four** conditions of the land which may make it necessary to carry out reclamation practices. [2marks]
2. List **three** physical weathering agents in the soil formation process [1<sup>1</sup>/<sub>2</sub>]
3. State **two** mechanical methods of separating soil particles according to size during soil analysis [1marks]
4. Give **two** benefits of possessing a land Title Deed to a farmer. [1mark]
5. Give four advantages of crop rotation [2 marks]
6. State four factors that should be considered when classifying crop pest
7. State **three** functions of boron in crop development. [1<sup>1</sup>/<sub>2</sub>]
8. Outline **four** observable indicators of economic development of a nation [2marks]
9. Give three factors that may influence the price of an agricultural commodity. [1<sup>1</sup>/<sub>2</sub>]
10. Name three examples of leguminous fodder crops. [1<sup>1</sup>/<sub>2</sub>]
11. Give two factors that may determine the size of a pit for silage making [1mark]
12. Give three reasons for controlling weeds in pastures. 1<sup>1</sup>/<sub>2</sub>
13. State six characteristics of a productive soil. ( 3 mks)
14. State any five qualities that should be considered when selecting seeds for planting ( 2 ½ mk)
- 15 (a) State four practices which encourage soil erosion ( 2 mks)  
(b) Name two forms of gulley erosion ( 1 mk)
16. (a) State four advantages of land consolidation ( 2 mks)  
(b) Give two advantages of leasehold tenure system in farming ( 1 mk)

### SECTION B ( 20 MARKS)

Answer all the questions in this section in the spaces provided

17. The table below shows the demand and supply of potatoes at UKULIMA market.

Price (Kshs)	Quantity demanded (in bags)	Quantity supplied (in bags)
1200	50	250
1000	90	200
800	150	150
600	225	70
400	335	0

- (a) Using suitable scales, draw and label a graph showing the relationship between the demand and supply of the potatoes at UKULIMA market. ( 5 mks)
- (b) What is the equilibrium price of the potatoes? ( 1 mk)
- (c) From the graph determine:
  - (i) The number of bags of potatoes that would be bought if the price per bag is Kshs 900/= ( 1 mk)
  - (ii) The price of a bag of potatoes if 180 bags are supplied ( 1 mk)

18. The diagrams labeled A<sub>1</sub>, A<sub>2</sub>, A<sub>3</sub>, and B below illustrate materials and methods of vegetative propagation. Study them and answer the questions that follow.

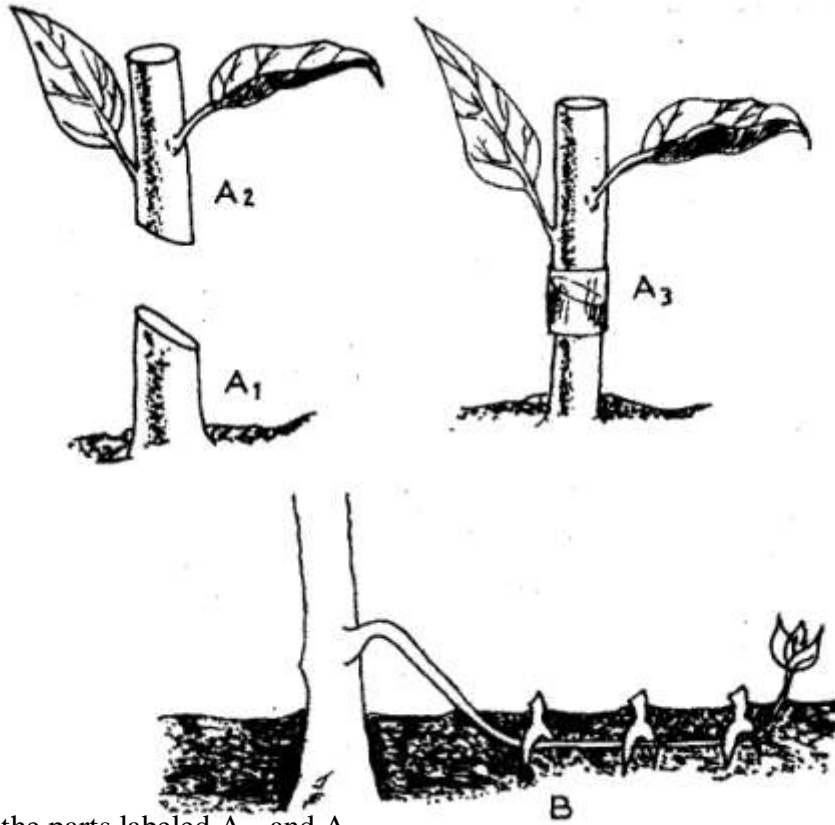

- (a) Name the parts labeled A<sub>1</sub>, and A<sub>2</sub> (2 mks)

A<sub>1</sub>

A<sub>2</sub>

- (b) Name the methods of propagation illustrated in diagrams A<sub>3</sub> and B (2 mks)

A<sub>3</sub>

B

19. Study the crop illustrated in the diagram below and answer the questions that follow

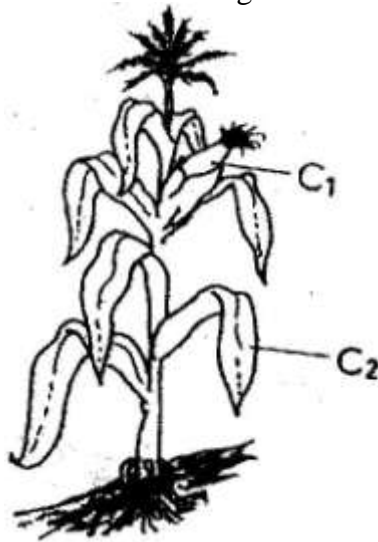

- (a) Name one insect pest which attacks the part labeled C<sub>1</sub> and one disease which attacks the part labeled C<sub>2</sub> (2 mks)

C<sub>1</sub>

C<sub>2</sub>

20. A member of young farmers club was advised to apply a complete fertilizer 30:20:10 in a tomato plot measuring 10m long by 5m wide at the rate of 300kg per hectare

- (a) State the percentage of P<sub>2</sub>O<sub>5</sub> in the complete fertilizer ( 1 mk)
- (b) Calculate the amount of fertilizer the member would require for the plot (2 mks) (Show your working)

21. The diagrams labeled D and E below are illustrations of coffee established using two different formative pruning systems. Study them and answer the questions that follow.



- (a) Name the system of pruning illustrated in diagram D above ( 1mk)  
(b) Outline how the pruning system illustrated in diagram E is carried out ( 2 mks)

**SECTION C (40 MARKS)**

*Answer any two questions in this section in the spaces provided after questions 24*

22. (a) Describe the field production of irrigated rice under the following sub-headings
- (i) Land preparation ( 7 mks)
  - (ii) Water control ( 6 mks)
- (b) Describe the management of trees grown under various agro- forestry systems ( 7 mks)
23. (a) Describe the problems of marketing of agricultural produce ( 10 mks)
- (b) Discuss the importance of budgeting in agricultural production ( 10 mks)
24. (a) Discuss the importance of irrigation in farming ( 12 mks)
- (b) Explain the factors that influence the type of irrigation to be used in a farm ( 8 mks)

**K.C.S.E 2007 AGRICULTURE PAPER 2**

**SECTION A (30 marks)**

*Answer ALL the questions in this section in the spaces provided.*

1. Give two reasons for using litter in a poultry house. (1mk)
2. Name two diseases of poultry that are controlled by vaccination. (1mk)
3. State two factors that could lead to failure to conceive in sows after service. (1mk)
4. Give two causes of scouring in calves. (1mk)
5. State three factors that would determine the amount of concentrate fed to dairy cattle.(1 ½ marks)
6. Give three ways of stimulating milk let-down in a dairy cow.(1 ½ marks)
7. State two reasons for dehorning cattle. (1mk)
8. List two equipment used in handling cattle during an agricultural exhibition.(1mk)
9. State three signs of anthrax infection disease observed in the carcass of cattle.(1 ½ mks)
10. Give three effects of external parasites that are harmful to livestock. (1 ½ mks)
11. State four factors to consider when siting a fish pond. (2mks)
12. State three adjustments that should be carried out on a tractor – mounted mouldboard plough in preparation for ploughing. (1 ½ mks)
13. a) Name four breeds of dairy goats. (2mks)  
b) Mention two distinguishing characteristics of the Bactrian camel breed. (1mk)
14. State five methods of maintaining good health in livestock. (2 ½ mks)
15. List four sources of farm power which are environmental friendly. (2mks)
16. State three maintenance practices that should be carried out on a feed trough. (1 ½ mks)
17. Name four systems of a tractor engine. (2mks)
18. List three types of calf pens. (1 ½ mks)
19. State four conditions that would encourage hens to eat eggs in poultry production (2mks)

**SECTION B (20 MKS)**

*Answer ALL the questions in this section in the spaces provided.*

20. The diagrams labeled A and B below show the teeth arrangements in hand workshop tools.

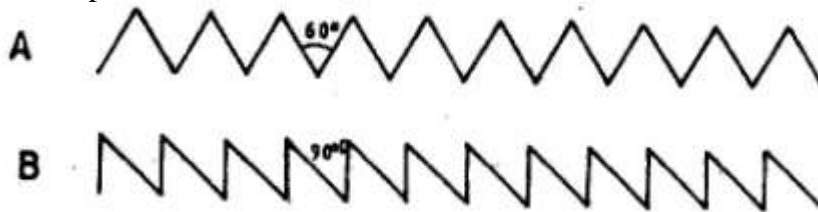

- a) Identify the tools represented with by the teeth arrangements A and B.(1mk)  
A .....  
B .....
- b) State one functional difference between tools represented by the teeth arrangements A and B.

A .....  
 B .....

c) Give two maintenance practices for the tools represented by the teeth arrangement shown above. (2mks)

21. a) The diagram below illustrates a method of identification in livestock production. Study the diagram and answer the questions that follow.

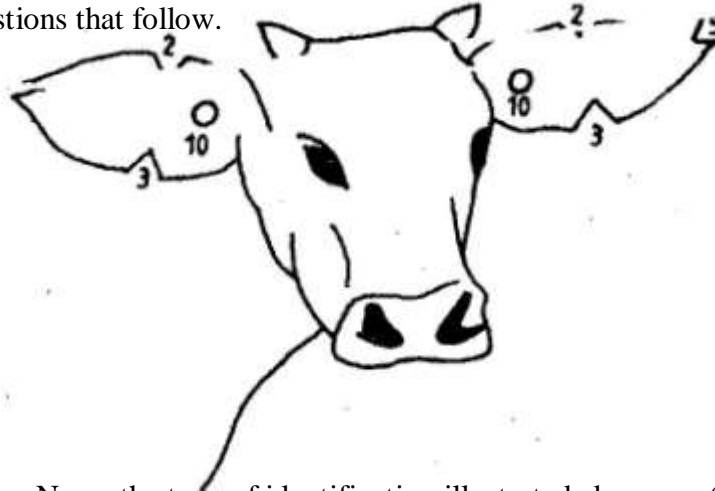

i) Name the type of identification illustrated above. (1mks)

ii) Give the identification number of the animal illustrated in the diagram above. (1mk)

iii) Using diagrams illustrate how you can identify animals Nos 24 and 36 using the above method. (2mks)

Animal No. 24

Animal No. 36

(b) If a sow was successfully served on 27<sup>th</sup> September, 2006, state the date she is likely to have farrowed. (1mks)

22. The diagram below shows a type of a farm gate. Study the diagram and answer the questions that follow.

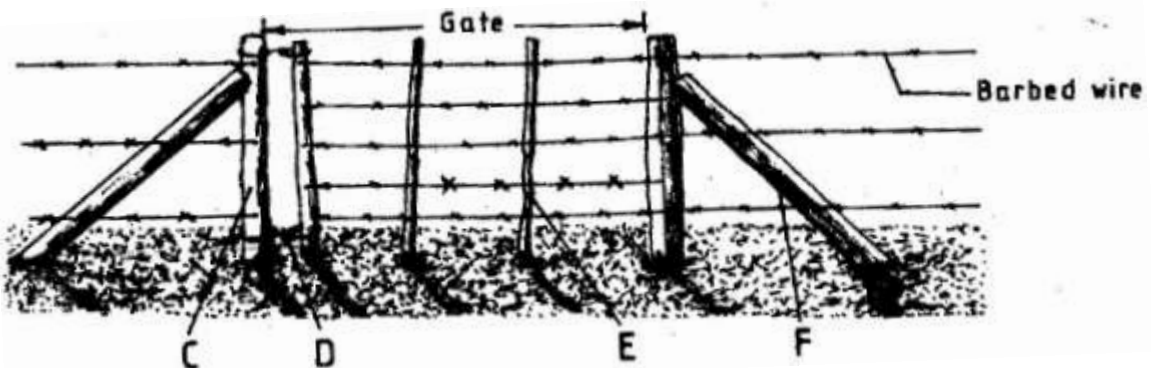

a) Identify the type of gate shown (1/2 mk)

b) Name the parts labeled C, D and E. (1 1/2 mks)

C .....

D .....

E .....

- c) i) State one function of the part labeled F. (1mk)  
F .....
- ii) State two functions of the gate illustrated above. (2mks)

23. The diagram below shows a farm implement. Study it and answer the questions that follow.

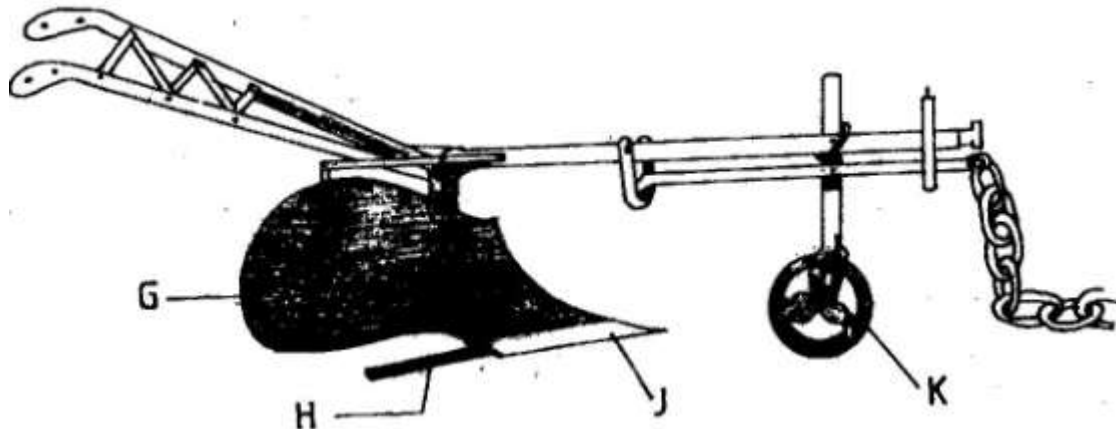

- a) Identify the farm implement illustrated above. (1mk)
- b) Name the parts labeled G, H, J and K.  
G .....
- H .....
- J .....
- K .....
- c) State four functions of the farm implement illustrated above. (2mks)

**SECTION C (40 marks)**

*Answer any TWO questions in this section in the spaces provided after question 26.*

- 24. a) Describe the advantages of the battery system of rearing layers. (10mks)
- b) Outline the factors to consider when selection livestock for breeding.
- 25. a) Name the strokes in a four stroke engine and describe how each operates.(12mks)
- b) Describe the functions of the gear box in a tractor. (8mks)
- 26. a) Name and describe the features of an ideal calf pen. (9mks)
- b) Discuss pneumonia in calves under the following sub – headings:
  - i) Predisposing factors (3mks)
  - ii) Symptoms (5mks)
  - iii) Control measures (3mks)