

NAME \_\_\_\_\_ ADMNO \_\_\_\_\_

SIGNATURE \_\_\_\_\_ DATE \_\_\_\_\_ CLASS \_\_\_\_\_

232/1  
**PHYSICS**  
**PAPER 1 (THEORY)**  
**2 HOURS**

## ASUMBI GIRLS HIGH SCHOOL

### TERM 2 – DECEMBER 2021

### FORM 4 – PHYSICS PAPER 1

#### INSTRUCTIONS

- Write your name and admission number in the space provided
- Sign and write the date of the examination in the space provided above
- This paper consists of two sections A and B.
- Answer all the questions in the spaces provided.
- All workings must be clearly shown.
- Mathematical tables and silent electronic calculators may be used.
- This paper consists of 11 printed pages. Candidates should check to ensure that all pages are printed as indicated and no questions are missing

For examiner's use only

SECTION	QUESTION	TOTAL MARKS	CANDIDATE'S SCORE
A	1-13	25	
B	14	12	
	15	10	
	16	12	
	17	10	
	18	11	
	GRAND TOTAL	80	

TOTAL CANDIDATE'S SCORE

Section A  + section B  =

232/1  
**Physics**  
**Paper 1**

**SECTION A (25 MARKS)**

**Answer all the questions in this section in the spaces provided.**

**(Take  $g=10\text{N/kg}$  or  $10\text{m/s}^2$ )**

1. The figure 1 below shows a wire wound on a test tube. The windings just touch each other. If the total number of complete loops was found to be 15, and the distance covered by the windings on the test tube is 20cm; find the radius of the wire. (2marks)

**Figure 1**

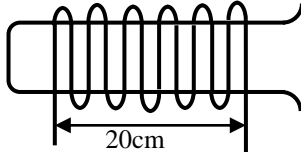

.....

.....

.....

2. A paratrooper flexes his legs when he lands. Explain (1mark)

.....

.....

3. A needle may float on clean water but sinks when a detergent is added. Explain. (1 mark)

.....

.....

4. The mass of a fabric of a large balloon is 100kg. the balloon is filled with 200 m<sup>3</sup> of helium and attached to a cable fixed to the ground as shown below.

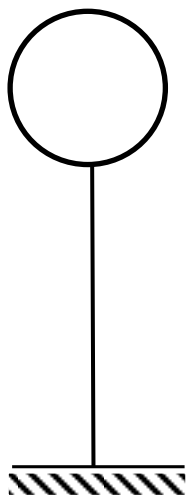

Given that the densities of air and helium are 1.3 kg/m<sup>3</sup> and 0.018kg/m<sup>3</sup> respectively, determine the tension in the string. (3 marks)

.....

.....

.....

.....

5. Water flows in a pipe of diameter 7cm at a speed of 5m/s. The water then gets to the perforated end which has 20 holes of diameter 0.7cm each. Determine the speed of water jets. (3 marks)

.....

.....

.....

.....

.....

6. For an enclosed system with a liquid, a force is applied at one point.  
 a) Briefly explain how force is transmitted to other parts of the system. (2 marks)

.....

.....

.....

.....

.....

b) State one application of such a system. (1 marks)

.....

.....

7. A 150g mass tied on a string is whirled in a vertical circle of radius 30cm with a uniform speed. At the lowest position the tension in the string is 9.5N. Calculate the velocity of the mass. (3 marks)

.....

.....

.....

.....

.....

8. A spring of elastic constant K has its length increased from 4.00m when unloaded to 4.25m when loaded with a 75N weight. Assuming that the elastic limit is not exceeded, determine the value of K. (2 marks)

.....

.....

.....

.....

9. The figure 2 below shows a glass tube fitted on to a boiling tube filled with water. State and explain what is observed when the boiling tube is heated. (2marks)

Figure 2

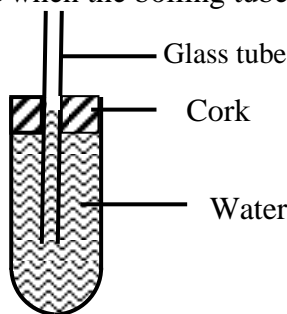

.....

.....

10. A bus that carries goods in the roof carrier is less stable than one that carries goods in the boot. Explain why this is so. (1 mark)

11. A rod consists of glass on one part and copper on the other. The rod is wrapped with a piece of paper and then a flame passed below it. It is observed that the paper on the side with glass is charred while that on the side of copper is not. Explain this observation. (1 mark)

12. The figure 3 below shows a uniform 50cm rod. It is balanced horizontally by a load of 4N on one end. Calculate the weight of the rod. (2marks)

fig. 3



13. The figure 4 below shows a bimetallic strip cooled below room temperature. Sketch on the side the bimetallic strip at room temperature. (1Mark)

Figure 4.

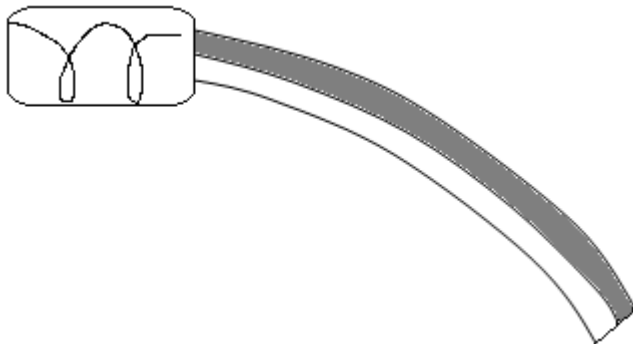

**SECTION B (55 Marks)**

**Answer all questions in this section in the spaces provided.**

14. a) Define “absolute zero temperature” for an ideal gas (1 Mark)

.....

.....

b) Using kinetic theory, explain Boyle’s law for an ideal gas. (2Marks)

.....

.....

.....

c) The diagram shows an experiment to investigate the relationship between volume and temperature of a fixed mass of gas at constant pressure.

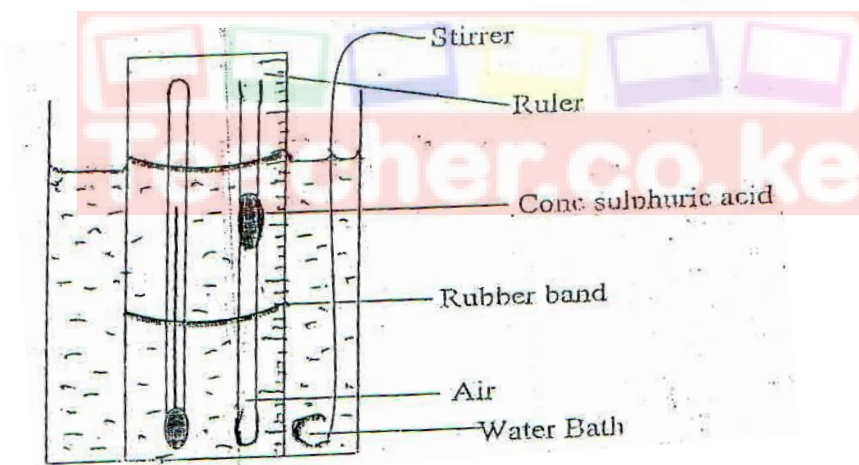

i) Explain the function of;  
(I) Concentrated sulphuric acid (1 Mark)

.....

.....

(II) Stirrer (1 Mark)

.....

.....

ii). Explain how the set up above can be used to verify Charles law for an ideal gas (3Marks)

.....

.....

.....

.....

iii. On the grid below sketch a graph of volume ( $\text{cm}^3$ ) against temperature ( $^{\circ}\text{C}$ ). Mark with letter T the absolute zero temperature. (2 Marks)

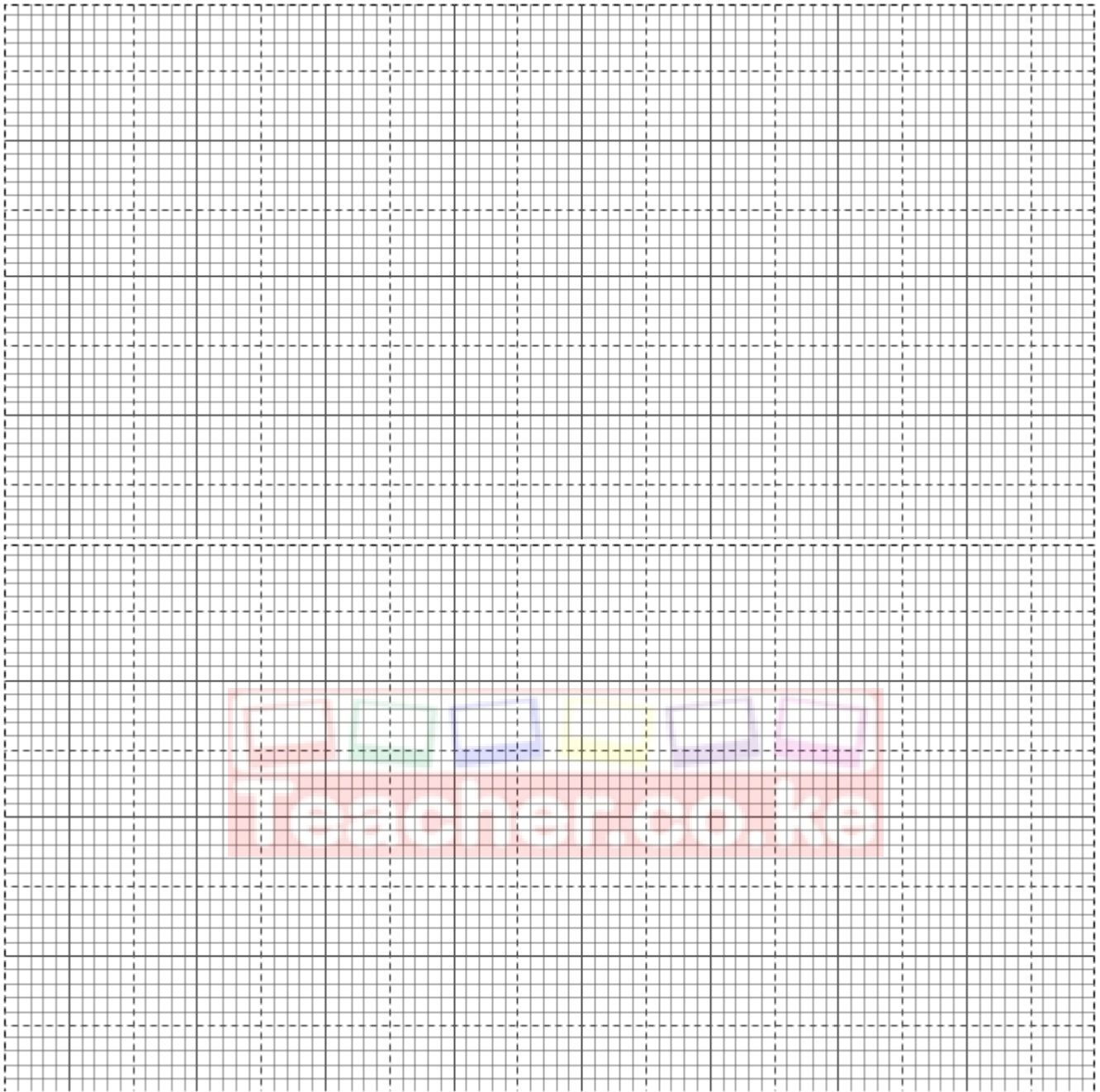

(d) A column of air 20cm long is trapped by mercury thread 6cm long as shown in figure 7 (a) below.

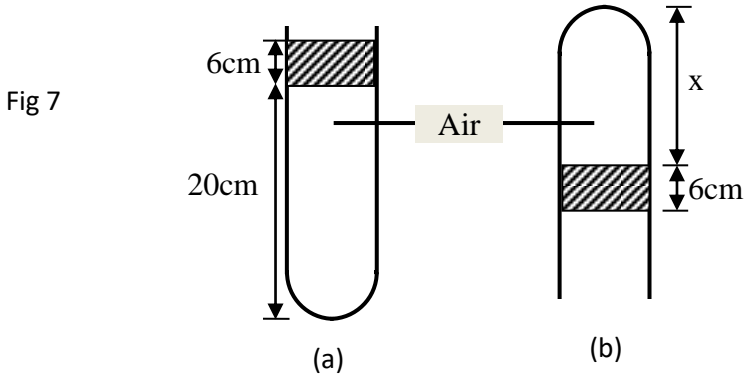

If the tube is now inverted, determine column X in figure b). Take atmospheric pressure as 76cm of mercury. (2Marks)

15. The figure 8 below shows an experimental set up for estimating the diameter of an oil molecule.

Figure 8

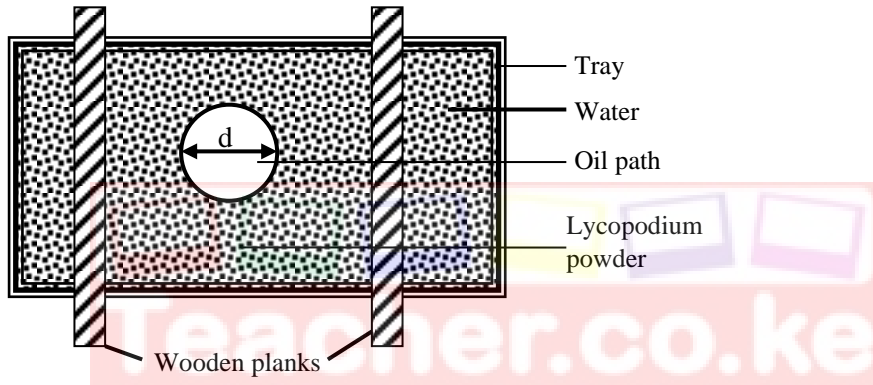

a) Describe how the oil patch is formed (2Marks)

b) i) In this experiment the diameter 'd' of the oil patch was measured to be 21cm for an oil drop of radius 0.28mm. Determine the diameter of the oil molecule. (3Marks)

ii) State any two assumptions made in calculating the diameter of the oil molecule. (2Marks)

c) What is the role of the lycopodium powder in this experiment? (1Mark)

d) Describe one method of determining the diameter of an oil drop.

(2Marks)

16. The figure 9 below shows the pattern formed on a tape in an experiment to determine the acceleration of a trolley. The frequency of the ticker tape used was 50Hz

**Figure 9**

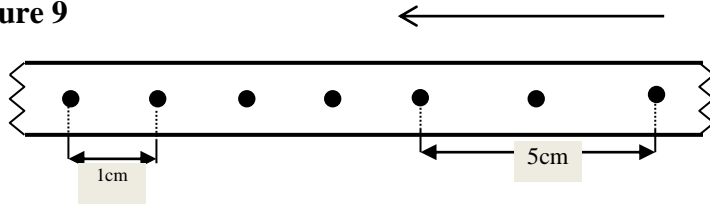

Calculate

i) The initial velocity of the trolley

(2Marks)

ii) The final velocity of the trolley

(2Marks)

iii) The acceleration of the trolley

(2Marks)

b) A gun is fired vertically upwards from the top of an open truck moving horizontally at a uniform velocity of 50m/s. The bullet attains a maximum height of 45m.

Calculate

i) The time taken by the bullet to reach the maximum height

(3Marks)

ii) The distance covered by the truck just before the bullet reaches the level from which it was fired.

(3Marks)



17. A man used a wooden plank to lift a wooden log from the ground to a stationary truck as shown in the figure. The wooden plank is inclined at an angle of  $30^\circ$  to the ground.

Figure 10

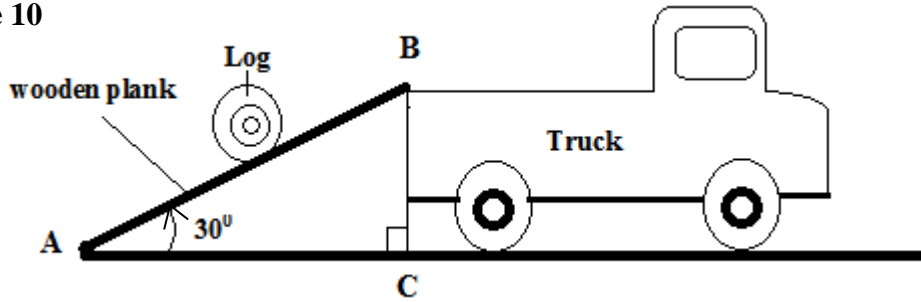

i) Show that the velocity ratio of the system is given as  $V.R = \frac{1}{\sin 30^\circ}$  (3Marks)

.....

.....

.....

.....

ii) Given that the system is 65% efficient, determine the Mechanical Advantage. (3 marks)

.....

.....

.....

iii) Explain why the efficiency of this system cannot be 100%. (1Mark)

.....

.....

b) The figure 11 shows a pulley system.  
Figure 11

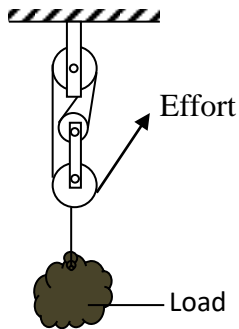

i) State the velocity ratio of the machine. (1Mark)

.....

.....

ii) Explain what happens to the Mechanical Advantage of the machine as the load is increased gradually. (1Mark)

.....

.....

c) Water drops from a waterfall to the bottom. The temperature of the water is found to be higher at the bottom than at the top. State the energy transformations. (1Mark)

.....

.....

18. a) Define “specific heat capacity” of a substance

(1Mark)

.....  
 .....

b) In an experiment an aluminium block of mass 2kg was heated using an immersion heater as shown in figure 12 below

Figure 12

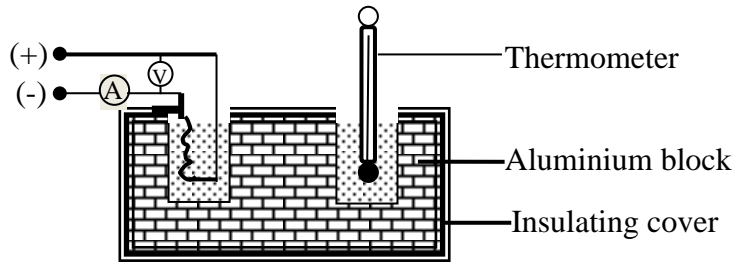

The temperature of the block was recorded every minute for exactly five minutes and then the heater was switched off. A graph of temperature in  $^{\circ}\text{C}$  against time in minutes for the experiment is shown below.

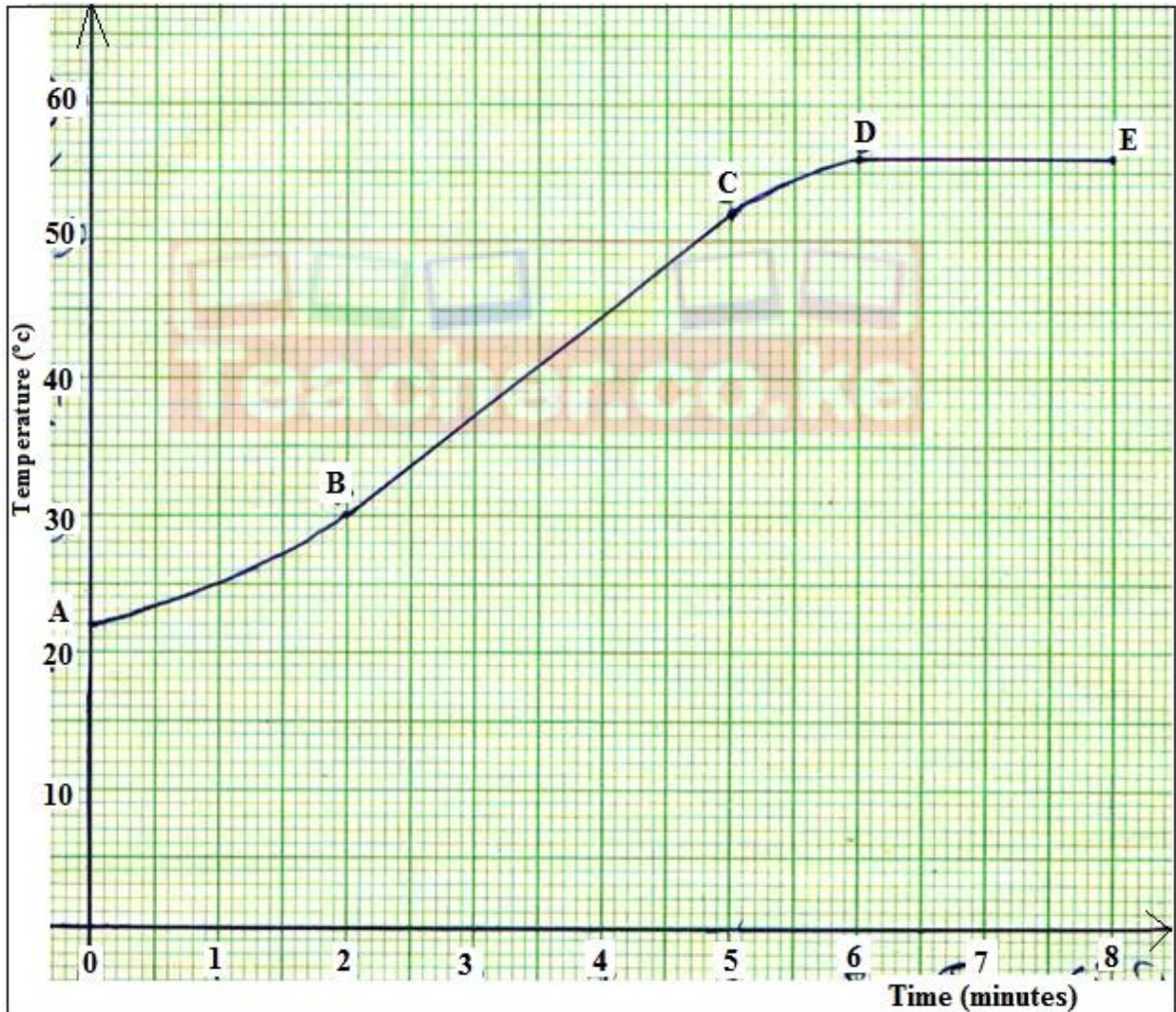

Figure 13

Study the graph above and answer the questions that follow.  
Suggest why;

i) The reading in the thermometer rose relatively slowly between point A and B. (1Mark)

.....  
.....

ii) The temperature continued to rise after the heater was switched off (1Mark)

.....  
.....

iii) Use the straight portion of the graph (Bto C)to calculate the specific heat capacity of the aluminium given that the voltmeter read 22.00V and ammeter 10A throughout the course of the experiment. (3Marks)

.....  
.....  
.....

c) Explain the two reasons why the value calculated in b) iii) will not be accurate. (2Marks)

.....  
.....

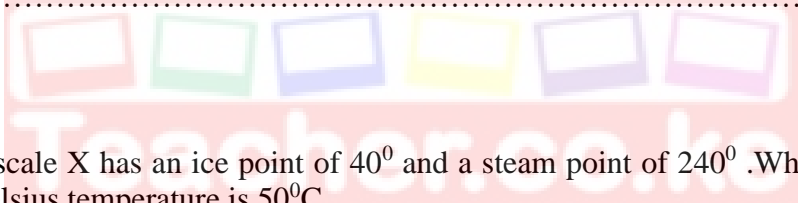

d) A temperature scale X has an ice point of  $40^{\circ}$  and a steam point of  $240^{\circ}$  .What is the temperature in  $X^{\circ}$  when the Celsius temperature is  $50^{\circ}\text{C}$ . (3Marks)

.....  
.....  
.....