

CHM 191: INTRODUCTORY PRACTICAL CHEMISTRY 1

COURSE DEVELOPMENT

Course Developer:

Dr. Femi Peters
National Open University of Nigeria
Lagos

Units Writer:

Dr. Femi Peters
National Open University of Nigeria
Lagos

Programme Leader:

Dr. M. Oki
National Open University of Nigeria
Lagos

Course Coordinator:

Mr. Adakole Ikepe
National Open University of Nigeria
Lagos.



NATIONAL OPEN UNIVERSITY OF NIGERIA

National Open University of Nigeria
Headquarters
14/16 Ahmadu Bello Way
Victoria Island
Lagos

NOUN Building
No 5, Dar Es Salaam Street,
Off Aminu Kano Crescent, Wuse
11, Abuja Nigeria

e-mail: centralinfo@nou.edu.ng
url: www.nou.edu.ng

(c) National Open University of Nigeria 2007

ISBN: 978-058-577-X

All Right Reserved

Printed by: Prime Link Investment Nigeria Limited, Abuja.
For National Open University of Nigeria

CONTENTS

MODULE 1:

	Page
QUANTITATIVE (INORGANIC) ANALYSIS	1
1.0 Introduction	1
2.0 Objectives	2-3
UNIT: 1 APPARATUS AND EXPERIMENTAL TECHNIQUES	4
1.0 Introduction	4
2.0 Objectives	4
3.0 Laboratory regulations and safety	4-8
4.0 Laboratory note book	9-10
5.0 Laboratory apparatus and operations	10
5.1 Heating	11-14
5.2 Evaporation	14
5.3 Precipitation	14
5.4 Digestion	15
5.5 Filtration	15-18
5.6 Drying and ignition of precipitates	18-19
5.7 Cooling	20
5.8 Volumetric tools and techniques	20
5.8.1 Volumetric flask	20-21
5.8.2 Pipette	21-22
5.8.3 Burettes	23
5.8.4 The conical flask	23
5.9 Common laboratory reagents	24-25
6.0 Summary	25
UNIT 2: UNITS OF MEASUREMENT	26
1.0 Introduction	26
2.0 Objective	26
3.0 Units of measurement	26-27
3.1 Unit of mass (m)	27
3.2 Units of volume (V)	28
4.0 Amount of substance	28
4.1 Concentration	29

4.2	Mole	29
4.2.1	Mole as applied to solid	30
4.2.2	The mole as applied to solution	30-31
4.2.3	Other units of concentration	32-33
5.0	Standard solution	33
6.0	Principles of dilution	34-37
7.0	Summary	37
8.0	Answers to SAQ'S	37-38
9.0	Tutor marked assignment	38
10.0	References and other resources	38

UNIT 3: UNITS OF MEASUREMENT 39

1.0	Introduction	39
2.0	Objectives	39
3.0	Experiment. Appreciation of a solution of known concentration and obtaining a diluted solution from the original solution	39
3.1	Introduction	39
3.2	Objectives	40
3.3	Principles	40-41
3.4	Requirements	42
3.5	Procedure	42-43
3.6	Observation and results	43
4.0	Experiment 1B	43
4.1	Objectives	44
4.2	Principles	44
4.4	Requirements	44
4.5	Procedure	44-46
4.6	Exercise	46
4.7	Answer	46

UNIT 4: PREPARATION OF A NON-STANDARD SOLUTION AND STANDARDIZING SAME. 47

1.0	Introduction	47
2.0	Objectives	47
3.0	Experiment 2A	47
3.1	Introduction	47
3.2	Objectives	48
3.3	Principle	48

3.4	Requirements	48
3.5	Procedure	48-49
3.6	Observations and results	49
3.7	Treatment of results	49
3.8	Exercise	49
4.0	Experiment 2B	50
4.1	Introduction	50
4.2	Objectives	50
4.3	Procedure	51
4.4	Results	51
4.5	Treatment of results	52
5.0	Conclusion	52
6.0	Summary	52

UNIT 5: VOLUMETRIC ANALYSIS

		53
1.0	Introduction	53-55
2.0	Objectives	55
3.0	Acid-base titration	55
3.1	Introduction	56-57
3.2	Indicator	57-58
3.2.1	ph Scale	58
3.2.2	Choice of indicator in acid-base titrations	58
3.2.3	Wrong use of indicator	58-59
3.3	Problem solving in acid-base titrations	59-60
3.3.1	Writing balanced chemical equation	60
3.3.2	Calculation of molar concentration	61-63
4.0	Conclusion	63
5.0	Answers to SAQ'S	63
6.0	References and other resources	63

UNIT 6: ACID-BASE II STANDARDIZATION OF A NON-STANDARD SOLUTION

		64
1.0	Introduction	64
2.0	Objectives	64
3.0	Experiment	64
3.1	Requirement	64
3.2	Procedure	65
3.3	Results	65-67
4.0	Conclusion	67

5.0	Answers	67
UNIT 7: ACID-BASE II DETERMINATION OF PERCENT PURITY OF A SUBSTANCE		68
1.0	Introduction	68
2.0	Objectives	69
3.0	Experiment	69
3.1	Requirements	69
3.2	Procedure	69
3.3	Results	70
3.4	Treatment of results	70-72
4.0	Conclusion	72
5.0	Answers to SAQ	72
UNIT 8: ACID-BASE IV DETERMINATION OF CONCENTRATION OF A SUBSTANCE IN EXCESS (BACK TITRATION)		73
1.0	Introduction	73
2.0	Objectives	73-74
3.0	Experiment	74
3.1	Requirements	74
3.2	Procedure	74-75
3.3	Results	75
3.4	Treatment of results	76-77
4.0	Conclusion	78
5.0	Answers to SAQ'S	78
UNIT 9: ACID-BASE V DETERMINATION OF THE AMOUNT OF NaOH AND Na ₂ CO ₃ IN A MIXTURE (DOUBLE INDICATOR METHOD)		79-80
1.0	Introduction	80
2.0	Objectives	80
3.0	Experiments	80-81
3.2	Procedure	81-82
3.3	Results	82
3.4	Treatment of results	82-83
4.0	Conclusion	84
5.0	Tutor marked assignment	84
MODULE 2:		85

QUANTITATIVE PHYSICAL IN ORGANIC ANALYSIS	85
1.0 Introduction	85-86
2.0 Objectives	86
UNIT 10: OXIDATION-REDUCTION REACTIONS	87
1.0 Introduction	87
2.0 Objectives	88-89
3.0 Theory	89-92
3.1 Oxidizing and reducing agents	92
3.2 Balancing redox equations	92
3.2.1 The ion electron method	92-94
3.2.2 The oxidation state method	94-95
4.0 Conclusion	95
5.0 Summary	96
6.0 References and other resources	96
7.0 Tutor marked assignment	96
UNIT 11: REDOX TITRATION II. USE OF POTASSIUM PERMANGANATE AS AN OXIDANT.	97
1.0 Introduction	97
2.0 Objectives	97-98
3.0 Experiment	98
3.1 Introduction	98-99
3.2 Objectives	99
3.3 Requirement	100
3.4 Procedure	100-101
3.5 Result	101
3.6 Treatments of results	101-102
4.0 Conclusion	102
5.0 Summary	102-103
UNIT 12: REDOX TITRATION III USE OF POTASSIUM	104

PERMANGANATE AS AN OXIDANT

1.0	Introduction	
2.0	Objectives	104
3.0	Experiment	104
3.1	Requirement	104
3.2	Procedure	104
3.3	Results	105
3.4	Treatments of results	106
4.0	Conclusion	106-107
5.0	Summary	107
		107

UNIT 13: REDOX TITRATION IV USE OF POTASSIUM PERMANGANATE AS AN OXIDANT 108

1.0	Introduction	
2.0	Objectives	108
3.0	Theory of oxidizing action of iodine	108
1.2	Indicators for iodimetry/iodometric titrations	108-110
2.0	Objectives	110-111
3.0	Experiment	111
3.1	Introduction	111
3.2	Objectives	111-112
3.3	Requirements and procedure	112
3.5	Results	112
3.6	Treatment of results	112-113
4.0	Conclusion	114-115
5.0	Summary	115
		115

UNIT 14: REDOX (REACTIVITY) SERIES IN METALS 116

1.0	Introduction	
2.0	Objectives	116
3.0	Experiment 1.	116
3.1	Introduction	116
3.2	Objectives	116-117
3.3	Requirements	117
3.4	Procedure	117
3.5	Results	117
3.6	Treatment of result	118
4.0	Experiment	118
4.1	Introduction	118
		119-120

4.2	Objectives	120
4.3	Requirement	120
4.4	Procedure	120-122
4.5	Results	122
4.6	Treatments of result	122
5.0	Conclusion	123
6.0	Summary	123

UNIT 15: ENERGY EFFECTS IN CHEMICAL REACTIONS 124

1.0	Introduction	124
2.0	Objectives	124
3.0	Experiment 1.	124
3.1	Introduction	124-125
3.2	Requirements	125-126
3.3	Procedure	126
3.4	Results	126
3.5	Treatment of results	127
4.0	Experiment 2.	127-128
4.1	Introduction	128
4.2	Requirements	128-129
1.3	Procedure	129
1.4	Results	129
4.5	Treatment of results	130
5.0	Conclusion	130
6.0	Summary	

Module 1:

Quantitative (Inorganic) Analysis

1.0 Introduction

We wish to introduce you to the first set of experiments you will be performing in chemistry during your programme with NOUN. These sets of experiment seek to describe how you can determine the relative amounts of components in a sample. It is called **Quantitative Analysis**. It enables you to determine how much of a component is present in a sample to be analysed. This is unlike qualitative analysis which you will come across in the next practical chemistry course and which indicates, through a systematic and logical manner, the identity of the component contained in the sample to be analysed.

There are many methods of performing quantitative analysis. There is the gravimetric method, there are the instrumentation methods, and there is the spectrophotometric method of analysis. The method we shall be concerned with is titrimetric (volumetric) analysis. Volumetric analysis is the determination of concentrations of solutions by titrating the solution with another solution whose concentration is known. It involves weighing, preparing a solution and titrating. In this course, firstly, we shall perform titration experiments involving acid – base compounds. Thereafter we shall go into redox reactions where we shall titrate an oxidizing agent with a reducing agent.

Finally, we shall draw your attention to energy relations in chemical reactions. This latter part is to introduce you to physical chemistry which you will encounter at a higher level practical chemistry course.

In module 1 of this Introductory Practical Chemistry 1 course, CHM 191, our main emphasis shall be to introduce you to Acid – base volumetric quantitative analytical methods. Before we go into experiments, we shall expose you to simple laboratory techniques, laboratory apparatus and operations such as heating, evaporation, cooling and weighing.

Some of these techniques and operations you will need at this level of your programme, some you will need at later levels of your

programme. We shall describe laboratory safety rules and precautions to you and explain the use of some of the tools you will specially use for volumetric analysis. All these are contained in unit 1 of this module. In unit 2, we shall familiarise you with how you can express concentrations of solutions and the different units that can be used for such expressions.

We will also expose you to the concept of mole which we believe will not only enhance your understanding of this practical course but will further improve your understanding of the general principle of chemistry. In volumetric analysis, our main desire is the determination of concentration of a solute in a definite volume of solution in which it is contained. This we shall take you through.

Finally, we shall concentrate our practical experiments on acid – base titration as an example of quantitative volumetric analysis. In particular, we will consider the techniques of standardisation of non – standard aqueous solutions and the determination of amounts of substances in such aqueous solutions. Units 3, 4, 5, and 6 deal with such fundamental but simple acid – base titrations involving preparation of a solution and titrating this solution against another solution whose concentration may or may not be known. In units 7, 8, 9 and 10, simple applications of acid – base titrations are demonstrated to acquaint you with the depth to which acid – base volumetric analysis can be applied.

2.0 Objectives

After going through this module and performing the experiments set in it, you would be able to:

- Use the tools necessary to perform experiments in volumetric analysis
- Calculate concentrations of solutions from titration data.
- Relate choice of indicator to type of reaction
- Determine the purity or impurity of a sample.

- Know what type of reactions are classified as acid- base reactions
- Determine the stoichiometric mole ratio from a balanced acid - base reaction equation.

UNIT 1: APPARATUS AND EXPERIMENTAL TECHNIQUES

1.0 Introduction

In this unit we will discuss some of the common experimental techniques, which you will use for carrying out experiments in this chemistry Laboratory course. We will also describe the apparatus required for various experiments, in addition to the common laboratory apparatus with which you are already familiar. Safety in the laboratory and preparation of a laboratory notebook are very important aspects of any laboratory course. We will, therefore, first of all describe the safety measure, which you should always take cognizance of in a chemistry laboratory; and how to prepare a laboratory notebook.

2.0 Objectives

After studying this unit, you should be able to:

- Take proper safety measure while working in a chemistry laboratory
- Record experiments in laboratory note books
- Identify and properly handle the laboratory apparatus, and
- Perform common laboratory operations such as heating, evaporation, precipitation, digestion, filtration, drying, ignition, cooling and weighing etc.

3.0 Laboratory Regulations and Safety

Chemistry laboratories are potentially dangerous place because they contain inflammable liquids, poisonous chemicals and fragile glass wares. Where high – pressure cylinders of gases are used, they also pose a potential danger. Safety in laboratory is important not only to you, but to other students and staff also in the laboratory. Therefore, proper precautions must be taken and safe experimental procedure must be followed while working in a chemistry laboratory.

Some important general safety precautions are given below. Any special precautions or safety measures, if required, are given in the

particular experiments. You should read all these carefully and follow them faithfully.

- Wear a lab coat or an apron when working in the laboratory.
- Be familiar with the layout of the laboratory especially where fire extinguishers, blankets or the first aid box are.
- Learn the location of the nearest exit from your laboratory to the outside of the building.
- Never work alone in the laboratory
- Always wear safety glasses or goggles in the laboratory. Even if you are only washing glassware and are not doing any work yourself, other students working nearby may have an accident that involves you. Unlike many chemical reactions, damage to eyes is irreversible. If you wear spectacles, make sure that they contain shatterproof lenses.
- Check the glassware before using. It should not have any cracks or imperfections.
- Almost all organic liquids are inflammable and therefore should never be heated on naked flame. Instead, you should use a water bath, an oil bath or an electric hot plate.
- Keep test tube away from yourself and others while heating it on a burner.
- Most of the chemicals you will work with are poisonous to some degree. Even common substances such as mercury, benzene and carbon tetrachloride are poisonous and potentially dangerous. Therefore, all chemicals must be handled with caution. As far as possible direct contact with skin must be avoided. Rubber or plastic gloves can be worn while handling especially toxic compound. Never taste anything unless specifically directed to do so. Avoid inhaling vapours of any compound. A list of some hazardous chemicals and their harmful effects are given in table 1.

Table 1: List of hazardous chemicals and their effects.

Hazardous Chemicals	Effects
Salts of Ag, Sb, Ti, V, $C_2O_4^{2-}$, F, MnO_4 , H_2S	Most of these are very dangerous but only if swallowed. $AgNO_3$ causes caustic burns. Almost as poisonous as HCN. Exposure dulls the sense of smell.
SO_2 , NO_2 , Cl_2 , Br_2 , I_2 , HNO_3 , H_2SO_4 , HF	All are dangerous as well as unpleasant. When concentrated, all cause rapid destruction of the skin; HF is especially dangerous.
$HClO_3$, $HClO_4$ and their salts	Highly oxidizing.
Chlorinated alkanes, e.g. $CHCl_3$, CCl_4	Most of these are narcotics, causing mental confusion
Benzene	Toxic vapours causing dizziness and is suspected to be a cancer agent.
Benzoyl chloride	Irritant.
Ether, ethanol	Very highly inflammable
Nitrobenzene	Toxic vapours
Phenol	Burns the skin

- There will be no smoking, eating or drinking in the laboratory.
- Never heat a closed system, it will act as a bomb
- Never wear loose clothing which might drag into an experiment or open flame.
- No Bare feet or wearing of high heeled shoes are not allowed in the laboratory.
- Do not carry out unauthorized experiments.

- Do not remove chemicals or apparatus from the laboratory without permission.
- A fume hood must be used for handling dangerous substances and for carrying out reactions in which noxious gases are evolved.
- Ask your laboratory demonstrator for safe disposal of chemicals and glassware. Never pour solvents and other chemicals into the sink, put them into special containers for waste.
- Do not throw used filter papers or broken glassware into the sink, put them in dustbins.
- wash your hands with soap when you leave the laboratory after doing an experiment.
- Ensure that gas and water taps are closed before leaving the laboratory.

However, even if you are a careful worker and follow the rules of safety, accidents can occur – that's why they are called accidents. For such occasions, you must be fully equipped and must know what to do in such a case. There should be a first – aid box in every laboratory containing some common things like Dettol, Pure honey, Band – aid, Bandages, Cotton, etc. Generally, the most common accidents that occur are cuts, burns, fires, poisoning and rarely, an explosion. Let us see one by one, what first aid should be given to a student, when such a mishap occurs.

1) **Cuts**

The most common accidents in the chemistry laboratory are cuts from broken glassware. If you have a cut, wash the wound well with cold water immediately. If bleeding is severe apply pressure directly on the wound to stop the bleeding and then proceed to the health clinic.

2) **Burns:**

Burns generally caused by hot equipment can be treated as the cuts are treated, that is, wash the burnt part with cold water for sometime and

often apply pure honey to it. Chemicals very often cause burns too. Take. 2 gives you a list of remedies for a few chemicals reagents.

3) Fire

A small fire in the beaker, caused by the vapours of an inflammable liquid, can be extinguished by covering it with a watch glass. If the clothes catch fire, one should lie on the floor and wrapping a blanket around the body can smother the fire into extinguishing.

4) Poisoning

If one happens to swallow a poisonous chemical, plenty of water should be given if the person is conscious. For a corrosive poison, calcium hydroxide solution (lime water) should be given as soon as possible. An antidote should be given only in the case of non- corrosive poisons.

5) Explosion

Sometimes a faulty technique during the experiment can lead to an explosion. You should work with highly oxidizing or explosive chemicals only under strict supervision.

6) Chemical spill in the eyes

Flush eye(s) with large amounts of cold water. Then bathe the eyes with 5% boric acids if the accident involved a base or 50% sodium bicarbonate if the accident involved an acid.

Table 2 Remedies for a few chemical reagents

Chemicals	Remedy
Acids like HNO_3 , H_2SO_4 , NaHCO_3 , HCl	Wash with NaHCO_3 or 2M ammonium carbonate (leaves no residue on clothes), and then apply Vaseline or a soothing cream.
Alkalines, e.g., NaOH , KOH etc.	Wash with 1M acetic acid, then apply Vaseline or a soothing cream
Bromine	Wash with 2M ammonia, keep the affected part dipped in NaHSO_3 till bromine is

Phenol	washed off, and then apply Vaseline.
Sodium	Wash with ethanol and then hospital treatment Apply Ethanol on a cotton wool pad.

4.0 Laboratory Note Book

One of the important characteristics of a scientist is the habit of keeping good record of the work that has been done. The record should reflect all the planning that has gone in as well as the observations at different stages of the experiment.

A chemist must observe things like whether there was a colour change when the reactants were mixed or a reagent was added to the solution; whether a precipitate was formed or a gas evolved; whether the reaction was exothermic, and record them. These observations may appear insignificant but experience have proved it helpful in correct interpretation of an experimental result.

While preparing a laboratory notebook, the following important features may be kept in mind.

- Record all observations and data in the notebook at the time they are obtained. Never use scrap of paper for recording or noting things like weights of reactants taken, melting or boiling points, etc. they might get lost or mixed up.
- The record should be so thorough and well organised that on reading it, it should be possible for any one to understand what has been done and able to repeat it. It may not be necessary to copy out the exact procedure, since this is given in your laboratory manual. However, results should be summarized, conclusion drawn from each experiment and explanation provided if the results vary from those expected. Certain marks have been allotted for maintaining a good laboratory notebook.

Handwritten mark resembling a stylized 'R' or 'B'.

- The laboratory notebook is a complete log of all operations, dates times, and information must be entered regularly. A good format will be:

1. Title of experiment Date
2. Aim of the experiment
3. Brief outline of experimental procedure
 - Apparatus
 - Chemical Reagents
 - Brief Procedure
4. Data
5. Results
6. Calculations if necessary
7. Conclusion

- A bound notebook should be used for laboratory record. Special laboratory note books are available, one side of the pages being ruled and the other side blank.
- All entries must be made in ink. If you commit a mistake, it should be crossed and the correct entry should be made.
- The first few pages in the notebook should be left for making a list of contents.

5.0 Laboratory Apparatus and Operations

You will find at the next page of this study unit for this course, sketches and diagram, (figure 1) of common general laboratory apparatus you will encounter in the chemistry laboratory. You will be making use of them frequently. Make sure you familiarise yourself with each of them in your locker.

Wet chemical analysis and preparatory chemistry require the use of some other apparatus and laboratory operations with which you should become familiar. It is presumed that you are already familiar with common laboratory apparatus and glassware such as the test tubes, boiling tubes, beakers, burners, test tube stand, conical flasks, watch glasses, funnels, glass tubes, china dishes, pipettes, burettes, funnel stand, tripod stand, burette stand etc. In this section at proper places we will familiarise you with some more glassware and apparatus, which will be used in various experiments in this course.

Heating, evaporation, precipitation, digestion, filtration, drying and ignition, cooling, weighing are some of the important laboratory operations, which you will perform during your study of chemistry as part of your programme. Let us study these operations and some of the apparatus required for them in some details.

5.1 Heating

Heating is one of the common operations, which you frequently perform in a chemistry laboratory. You resort to heating for a variety of reasons. Heating increases the solubility of most substances. It also increases the rate of chemical reactions. You have to heat substance to dry them. In gravimetric analysis, the precipitate is sometimes heated to a high temperature to convert it into a compound of constant composition.

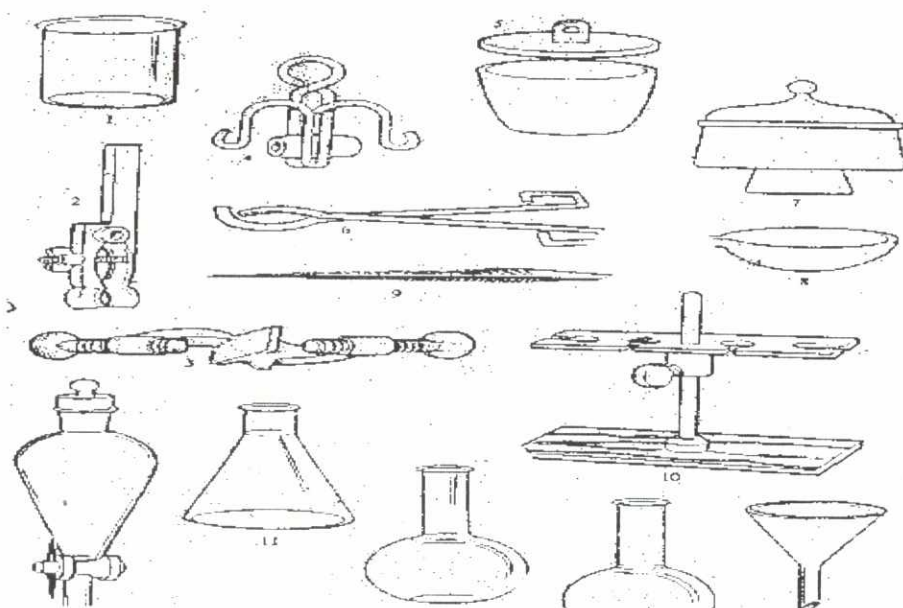

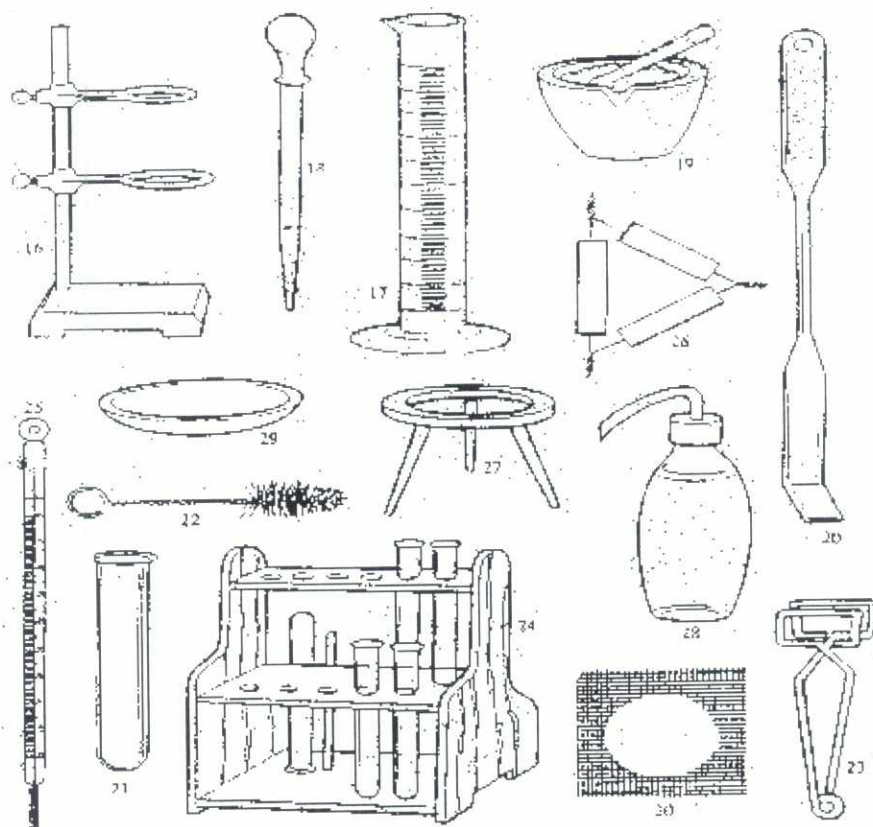

1. Beaker
2. Clamp
3. Clamp holder
4. Clip (Mohr's chip or rubber clip)
5. Crucible and crucible cover
6. Crucible tongs
7. Desiccator
8. Evaporating dish
9. File, triangular
10. Filter stand or rack
11. Flask, conical
12. Flask, flat bottom
13. Flask, round bottom
14. Funnel (filter)
15. Funnel (Separatory)
16. Iron stand and rings
17. Measuring cylinder
18. Medicine dropper
19. Mortar and pestle
20. Spatula
21. Test - tube
22. Test – tube brush
23. Test – tube holder
24. Test – tube rack
25. Thermometer
26. Triangle
27. Tripod or tripod stand
28. Wash bottle (plastic)
29. Watch glass
30. Wire gauze

Fig1. Common laboratory apparatus.

In all the chemistry laboratory courses, you will use the following heating devices:

- i. Bunsen burner
- ii. Water bath
- iii. Electric oven
- iv. Muffle furnace

The Bunsen burner is a widely employed heating device in an inorganic chemistry laboratory. It is used to attain moderately high temperature of up to 600°C . The maximum temperature is attained by adjusting the regulator so as to admit rather more air than is required to produce a non-luminous flame.

Boiling water bath are for heating solutions up to 100°C , for evaporation of liquids to reduce their volumes and for digestion of precipitates. The simplest form of a water bath is a beaker in which water is boiled. The vessel to be heated is kept on the rim of the beaker. Copper or Aluminum water bath as shown in fig.2. are commercially available. These have a copper or aluminum bowl fitted with a series of metallic rings to adjust the size of the opening. This allows heating of vessels of various sizes. The bath is partly filled with water and heated on a burner or electrically.

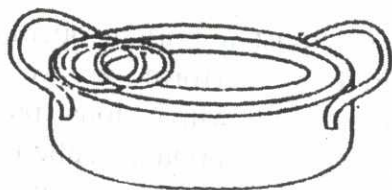

Fig. 2: A copper water bath

Electric ovens or drying ovens are very convenient heating devices. They have a temperature range from room temperature to about 300°C . The temperature can be thermostatically controlled to within $\pm 1 - 2^{\circ}\text{C}$. They are mainly for drying solids or precipitates and glasswares at comparatively low controlled temperature.

Electrically heated muffle furnaces are used to ignite sample to high temperature either to burn organic matter prior to inorganic analysis or to convert precipitates to a weighable form in gravimetric analysis. Temperature of up to 1200°C can be attained with muffle furnaces.

5.2 Evaporation

During experiments, you may be asked to reduce the volume of a solution. Sometimes you may have to evaporate a solution to dryness. Both these operations can be conveniently carried out in a porcelain – evaporating dish. Rapid evaporation can be achieved by heating the dish containing the solution directly on wire gauze. ‘

If corrosive fumes may evolve during evaporation, the process must be carried out in a fume hood. When evaporating to dryness, in order to avoid bumping and spattering, you should remove the dish from the burner whilst there is still liquid left. The heat capacity of the hot dish is sufficient to complete the operation without further heating.

You may also accomplish the reduction in volume of a solution by direct heating in a small beaker over a wire gauze or by heating in a boiling tube held in a holder over a naked flame. But while evaporating in a boiling tube, care must be taken that the liquid does not bump violently.

5.3 Precipitation

Precipitation is one of the most important operations, which you are very frequently required to perform in wet chemical analysis. **Precipitation** is a process in which ions present in solution is converted into an insoluble compound called **precipitate** by the addition of another compound called precipitant or precipitating reagent. Precipitation is usually carried out in test tube (in qualitative analysis) or in beakers (in quantitative analysis).

The solution of precipitant is added slowly by means of a dropper, pipette or burette and with efficient stirring. The solution of the precipitant is added down the side of the precipitating vessel by avoiding splashing. Only a moderate excess of the precipitant should be added.

A very large excess precipitant may sometimes lead to dissolution or contamination of the precipitate. After the precipitate has settled, a few drops of the precipitate should always be added to ensure complete precipitation.

5.4 Digestion

In gravimetric analysis, to ensure complete precipitation and to make all particles of filterable size, the precipitate is digested before filtration. Digestion also helps in reducing the amount of absorbed impurities. In some cases settling the beaker aside and leaving the precipitate in contact with the mother liquor at room temperature for 12 – 24 hours carry out digestion.

In others, where a higher temperature is permissible, digestion is usually effected by heating for 15 – 20 minutes near the boiling point of the solvent. The beaker is kept covered by a watch glass with its convex surface downward.

5.5 Filtration

Filtration is the process of separation of a solid (crystals or precipitate) from the liquid (mother liquor). Filtration is a very important and commonly used operation in chemistry laboratory. Filtration can be carried out either under atmospheric pressure (ordinary filtration) or under reduced pressure (suction filtration). Filters for filtering precipitate are of various types. We will discuss here three types of them:

- i. Filter papers
- ii. Sintered glass crucible
- iii. Porcelain Buchner funnel

Filter paper is frequently used to filter precipitates in qualitative analysis. In some gravimetric estimation, the precipitate is ignited at high temperature to convert it to a well – defined compound of known composition. For example, Fe^{3+} is precipitated as hydrated iron oxide, $\text{Fe}_2\text{O}_3 \cdot x\text{H}_2\text{O}$ and ignited Fe_2O_3 before weighing. When a precipitate is to be ignited, it should be collected in an ash less filter paper, which

leaves little residue on ignition. Filter paper is suitable when the precipitate is not easily reduced by the action of carbon of the paper on ignition.

Filter paper for quantitative analysis is made of various degrees of porosity. The filter paper used must be of such porosity as to retain the smallest particles of precipitate and yet permit rapid filtration.

Filter papers of three grades are generally made, one for very fine particles such as BaSO_4 , a second for average precipitates such as AgCl , which contain medium – sized particles, and a third for gelatinous precipitates such as $\text{Fe}_2\text{O}_3 \cdot x\text{H}_2\text{O}$.

Proper folding and fitting of the filter paper in the funnel can increase the rate of filtration. A properly folded filter paper is illustrated in fig. 3. The circle of filter paper is folded exactly in half. This is folded again in quarters in such a way that the vertices of the two quarters do not coincide, but are displaced about 3mm at the corners. The outside corner of the paper is the torn off and the paper placed in a glass funnel in such a way that three layers of filter paper are on one side a single layer on the other.

To seal the paper into funnel, the paper is moistened and the upper part pressed gently against the walls of the funnel with fingers. The upper edge of the filter paper should be about 1cm from the upper rim of the glass funnel. The filter should never be more than about two- thirds full of the solution. After the filter paper is seated in the funnel, the liquid containing suspended precipitate is poured down a glass rod into the funnel as illustrated in fig. 4. Care must be taken in transferring of the precipitate to avoid losses.

The particles adhering to the beaker or rod are removed by scrubbing the with walls with a moistened rubber porcelain. Wash the remainder of the loosened precipitate from the beaker and from the porcelain into the funnel.

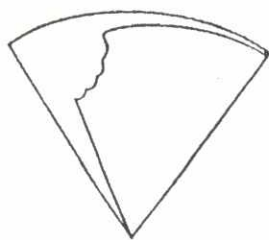

Fig. 3 A property paper filter

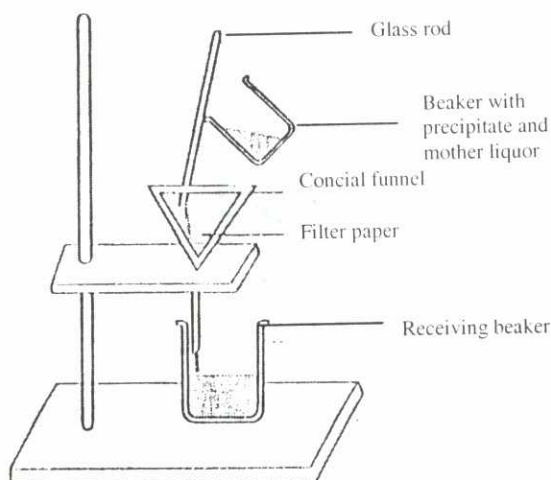

Fig. 4 Procedure for filtering a precipitate

After the precipitate is transferred to the filter, it is washed with five or six more portions of wash liquid. Add the liquid around the top edge of the filter paper to wash the precipitate down into the funnel. Each portion should be allowed to drain before adding the next one.

Ordinary filtration is generally a slow operation. It can be speeded up by use of suction filtration. If the filtration does not need to be ignited, it most conveniently collected in a sintered glass crucible (fig 5) by suction filtration. This crucible has a porous disk that allows the liquid to pass through, but retain solid particles. Suction can be applied by means of a water pump.

Water pump sucks out air, reducing the pressure inside the filtration flask and thus speeding up the rate of filtration. When a large quantity of precipitate or any other solid is to be filtered, a Buchner funnel, which is shown in fig. 6, is employed.

The Bucher funnel consists of a porcelain funnel in which a perforated plate is incorporated. A filter paper circle, cut correct to size covers the perforated plate. The Bucher funnel is fitted into the filter flask by means of a cork. The filter paper is wetted with water and suction put on before pouring in the solution to be filtered.



Fig.5 A sintered glass



fig. 6 A Buckner funnel crucible

5.6 Drying and Ignition of Precipitates.

In gravimetric analysis after a precipitate has been filtered and washed, it must be brought to a constant composition before final weighing is concluded. Drying or ignition of the precipitate achieves this. Whether a precipitate should be dried ignited depends upon the nature of the precipitate and upon the type of filtering medium used. Precipitates such as BaSO_4 , PbCrO_4 , AgCl , nickel dimethylglyoximate become dry and acquire a constant weight on heating up to 250°C . The precipitates of these type can be conveniently filtered in a sintered glass crucible and dried in an electric oven.

Here we would like to point out that the precipitates of the above type can also be filtered in ash less gravimetric filter paper and then ignited to a constant weight. But ignition requires a higher temperature of up to 1200°C .

Therefore, it is more convenient to filter them in a sintered glass crucible and dry in an electric drying oven. On the other hand, gelatinous precipitates such as those of $\text{Fe}_2\text{O}_3 \cdot x\text{H}_2\text{O}$ and $\text{Al}(\text{OH})_3$ clog the pores of the sintered filter crucible and therefore, are filtered through an ash less filter paper.

They also have a variable composition and should be ignited to convert them into a form of constant composition (such as Fe_2O_3 or Al_2O_3) suitable for weighing. Calcium is often precipitated as the oxalate, CaC_2O_4 , which is not weighed as such but is decomposed by ignition to CaO and then weighed.

Place a silica crucible on a clay pipe triangle kept on a tripod stand (fig. 7). Heat the crucible strongly for half an hour on a Bunsen burner

flame. Remove the burner and allow the crucible to cool in air for 2 – 3 minutes. Then place the crucible in a desiccator with the help of a pair of tongs (fig 8). Allow the crucible to attain the room temperature and then weigh it. Repeat the process of heating, cooling and weighing till the weight of the crucible becomes constant.

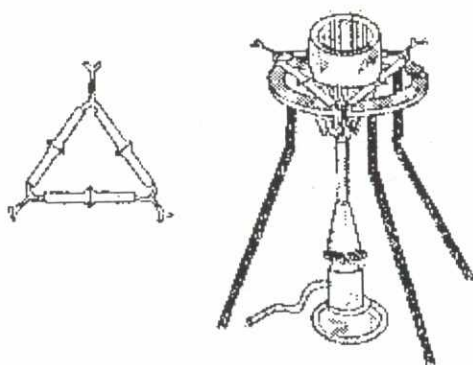

Fig.7. Heating a silica crucible

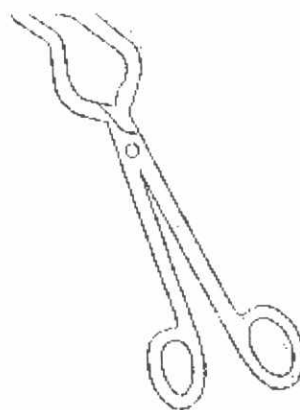

Fig 8. A pair of tongs

Detach carefully the well drained filter paper containing the precipitates from the funnel. Fold the filter paper into a packet so as to completely enclose the precipitate.

Place the packet into the weighed silica crucible supported on a clay pipe triangle and tripod stand. Tilt the crucible slightly and partially cover with the lid.

Place a small flame under the crucible so that the filter paper and the precipitate become dry. Then increase the flame slightly so as to slowly carbonize the paper. Do not allow the paper to burn, as this may cause a mechanical loss of the precipitate. If the paper catches fire, put off the fire by covering the crucible with the lid with the help of a pair of tongs.

When the paper has completely carbonized, increase the size of burner flame until the bottom of the crucible is heated to redness. Continue heating strongly until the carbon residue is burnt away. Cool the crucible in a dessicator and then weigh.

Repeat the process of heating, cooling and weighing till the weight of the crucible with the precipitate become constant.

5.6 Cooling

After the crucible and the precipitate have been dried in an electric – drying oven or heated strongly on a burner flame, they should be cooled to room temperature before weighing. Cooling is done in a desiccator as shown in fig. 9.

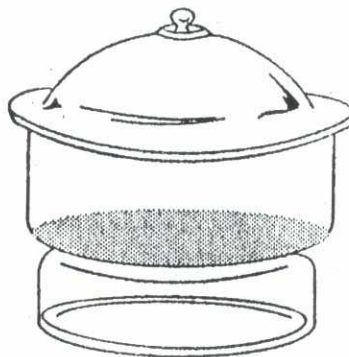

Fig. 9 A desiccator

A desiccator is an airtight container that contains a drying agent or desiccant such as anhydrous calcium chloride, silica etc. the desiccant absorbs moisture and keeps the air dry in the desiccators. The desiccant has to be changed from time to time as it becomes spent after absorbing moisture. The interface between the lid and the body of the desiccators is greased to make an airtight seal. The correct way to open a desiccators is to slide the lid side ways until it can be removed. When placing the lid on the table, the greased surface should be kept upwards.

5.8 Volumetric Tools and Techniques

These are tools and techniques commonly encountered during volumetric analyses.

5.8.1. Volumetric Flask

Volumetric flasks are flat bottom flasks with long necks designed to contain definite stated volumes of liquid. They are available in sizes ranging from 5cm^3 to 5dm^3 . Of these, the most commonly used in volumetric analysis is the 250cm^3 capacity flask.

Most of these flasks have round fit stoppers. A volumetric flask invariably has a calibration mark on its neck indicating the level to which the liquid must be added to reach the volume indicated as the capacity of the flask. Thus, volumetric flasks are used mostly for the preparation of standard solutions of a definite volume.

A brief method of filling the volumetric flask can be stated here. The material whose solution is to be prepared is weighed into a weighing container say a weighing bottle, watch glass etc. the material is then put inside a small beaker of capacity between 50cm^3 and 100cm^3 and dissolved with a small volume of distilled water.

The weighing material is itself rinsed with a small amount of water onto the beaker. More water is added to ensure the material is totally rinsed away from the weighing bottle. The beaker is allowed to cool to room temperature if it appears the body of the beaker is getting warm or hot. The cooled solution is then poured into the volumetric flask of definite volume and capacity through the use of a funnel placed on the mouth of the volumetric flask.. The beaker is rinsed with small volumes of water and the rinsing added to the flask.

The funnel is next rinsed by squirting water onto it from a wash bottle into the volumetric flask. After this is done, the funnel is removed from the mouth of the flask. Water is now added to the volumetric flask from the wash bottle up to its neck but not to the mark. The flask is stoppered and shaken thoroughly. It is allowed to settle and thereafter, water from the wash bottle is added to finally make it to the mark.

5.8.2 Pipettes.

Pipettes are used for transferring liquids or solutions from one container to another container. They are of two types. The commonest and the one you most likely will use is the transfer pipette. This is a long tube with a short cylindrical bulb at the middle. They have varying capacities between 1cm^3 to 50cm^3 . Of these the most commonly used for quantitative analysis are the 10 , 20 and 25cm^3 capacity pipettes.

The second type of pipette is the graduated or measuring pipette. This is a straight, uniform bore that is graduated along its length. It is used for delivering liquids of definite volume which are usually not up to the

round figure value of 10, 20cm³. If volumes greater than 20cm³ are required to be delivered, a burette will likely be the equipment to be used. A pipette is used to transfer liquids as follows.

The transfer pipette which must have been washed with soap and rinsed with water is seen to be clean and dry. It is now rinsed with the solution to be put into it about two times. The pipette is now placed in the bulk of the solution to be put into it about two times. The pipette is now placed in the bulk to be transferred with its tip well dipped inside the liquid and almost touching the bottom of the container containing the solution to be transferred. The liquid is sucked up to a level just above the calibration mark on the stem of the pipette. The top of the pipette is then closed with the tip of the fore finger while the pipette is being withdrawn from the liquid.

Whilst using your finger tip, and holding the pipette upright, you release the finger pressure to allow the solution to run out until the lower part of the meniscus falls on the mark. If there is any drop of the liquid hanging from the tip of the pipette, the tip of the pipette is made to just touch the bottom surface of the container containing the liquid. Do not off blow the remaining solution at the tip of the pipette.

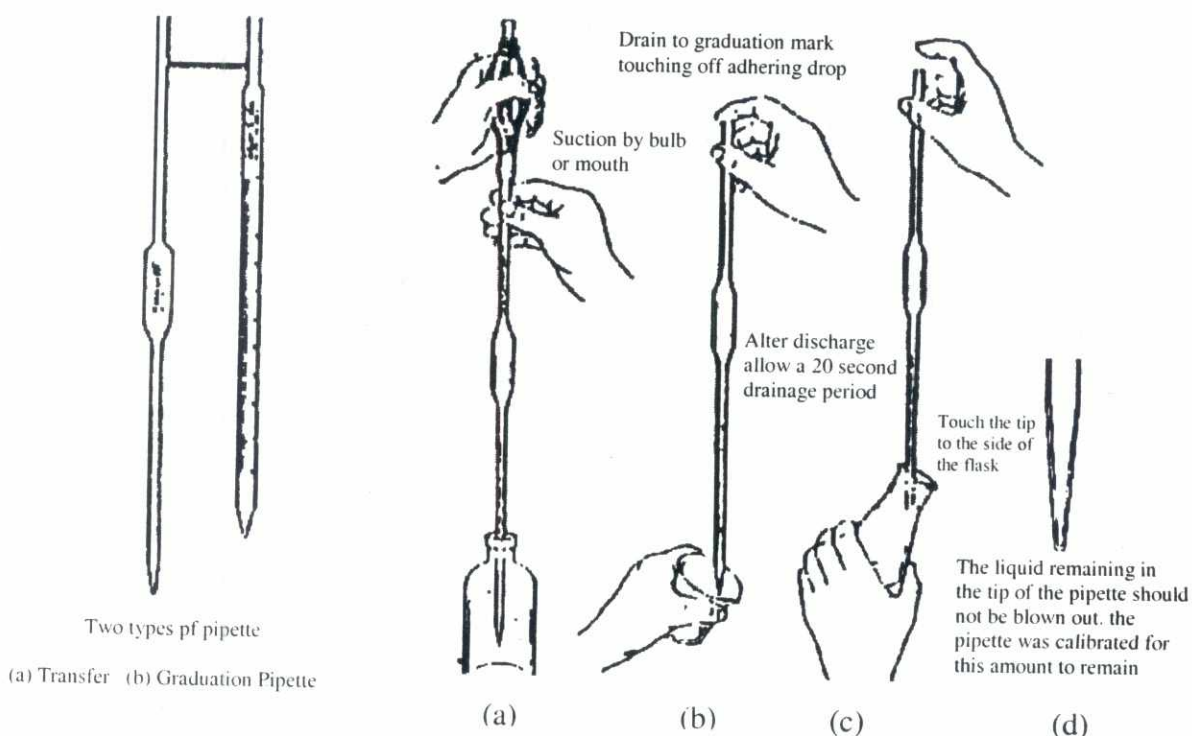

Fig. 8: How to transfer liquid with a pipette to a flask

5.8.3 Burette

A burette is a long glass tube fitted with a tap or stopcock through which the liquid contained in it is delivered via a small opening at one end. It is designed to measure accurately the volume of liquid delivered during a titration.

The commonest one has capacity of 50cm³ though there are other capacities and are all graduated at 1cm³ and 0.1cm³ respectively.

The burette readings can be reported to two decimal places. This normal practice is to read the lower part of the meniscus of a liquid in the burette. This part of reading the burette is often found to be inappropriate by some students as a result of errors due to light. So a card or a strip of paper is placed as the other side of the student such that the top of the strip is level with the bottom edge of the meniscus.

For intensely coloured solutions such as that from potassium permanganate, the top of the meniscus is read instead as light is not likely to affect your sight during reading of the burette.

A burette is used as follows. After ensuring that the burette is washed clean and dry, it is then rinsed two times with distilled water and allowed to drain by opening the tap or the stopcock. Lubricate the stopcock or tap with grease so as to prevent leakage. Now pour in the liquid usually through the use of a funnel placed on top of the mouth of the burette pass the mark on the graduate burette. Then remove the funnel immediately.

Now run the burette by opening the tap or stopcock so that the liquid runs out through the opening at the end of the burette thereby completely filling up the burette from the tip to the zero mark. A note of advice on the way the burette is run during titration. When running liquid out of the burette, use your left hand to open the tap and your right hand to hold the flask at the same swirling time as the titration proceeds.

5.8.4 The Conical Flask.

The conical flask is used in volumetric analysis as a container in which the reactants meet and the product is formed. The most conventional size for volumetric work is the 250cm³ conical flask.

5.9 Common Laboratory Reagents

You will be using a number of reagents and chemical during your experiments. There are laboratory assistants to help you to get reagents. Most of these chemicals are kept in the reagent shelves and are properly labelled. The bench shelves have mostly liquid

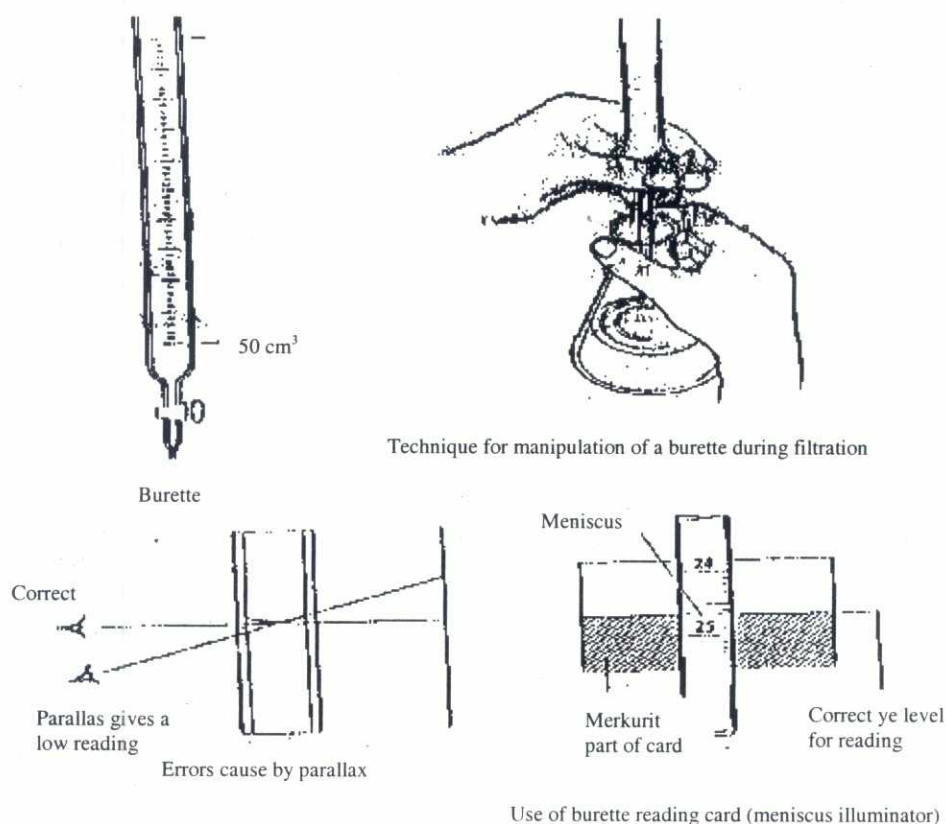

Fig. 9 How to read the level of liquid in a burette

reagents, which include hydrochloric, sulphuric and nitric acids. Besides these, other solutions like silver nitrate, ammonium hydroxide, sodium hydroxide, barium chloride, etc, may also be kept there. You have to be very careful while using all these, especially, the acids.

Mishandling any chemicals may result in injury. You should thoroughly read the section 3.0 in the unit before starting your experiment. Thus tells you about safety measures in the laboratory.

The solid reagents are kept on a common table. You should use a spatula and take only the required amount of the compounds from the bottle or the pack. Don't waste any chemical. The liquid should be taken with the help of droppers.

Your laboratory demonstrator will provide the special chemicals and solutions required for any experiment at the time of performing the experiment.

6.0 Summary

In this unit we have discussed the safety measure, which you should take while working in a chemistry laboratory. We also described the importance of keeping records of experiments, which you perform in the laboratory.

We discussed various laboratory operations, which you would perform in your degree programme. We also familiarized you with the common apparatus, which you will require for performing various experiments in this course.

UNIT 2: UNITS OF MEASUREMENT

1.0 Introduction

Weighing an object is a practice common in a chemistry laboratory. The object in this case is usually a salt, a compound, a reagent, water, or glass container. The result of weighing is the mass in weight of the object. Because chemistry is a scientific discipline, weighing must be definitive, reproducible and comparable with other weightings done in other laboratories.

Thus, measured or weighed quantities must be expressed in appropriate and comparable unit for proper understanding of the object in relation with other quantity. If we forget to give the units when reporting the result, the measurement will be meaningless as it will be difficult to interpret. It is therefore a must that all measurements must be accompanied with the appropriate unit.

2.0 Objective

At the end of this unit, you should be:

- Familiar with S.I. (international system) units of mass, volume, amount of substance, concentration
- Familiar with mole concept as applied to solids and solutions
- Familiar with other units of expressing concentrations of solutions
- Familiar with the principles of dilution
- Be able to calculate concentration of solutions

3.0 Units of measurement

Due to the varying tasks we would be carrying out in the laboratory experiments, you will discover that we shall be measuring such

quantities as the mass or weight, volume and length of materials or objects as the situation demands.

However for the purpose of this unit, we shall dwell more on mass and volume.

3.1 Unit of mass (m)

The base unit of a measured solid material say a bottle, or a salt is the kilogram, abbreviated as kg. However, its lower fractional unit, the gram g, is commonly used. Multiples e.g. metric ton, of it are also in use especially in a chemical industrial weighing operation. The relationship between the various kilogram units is presented thus.

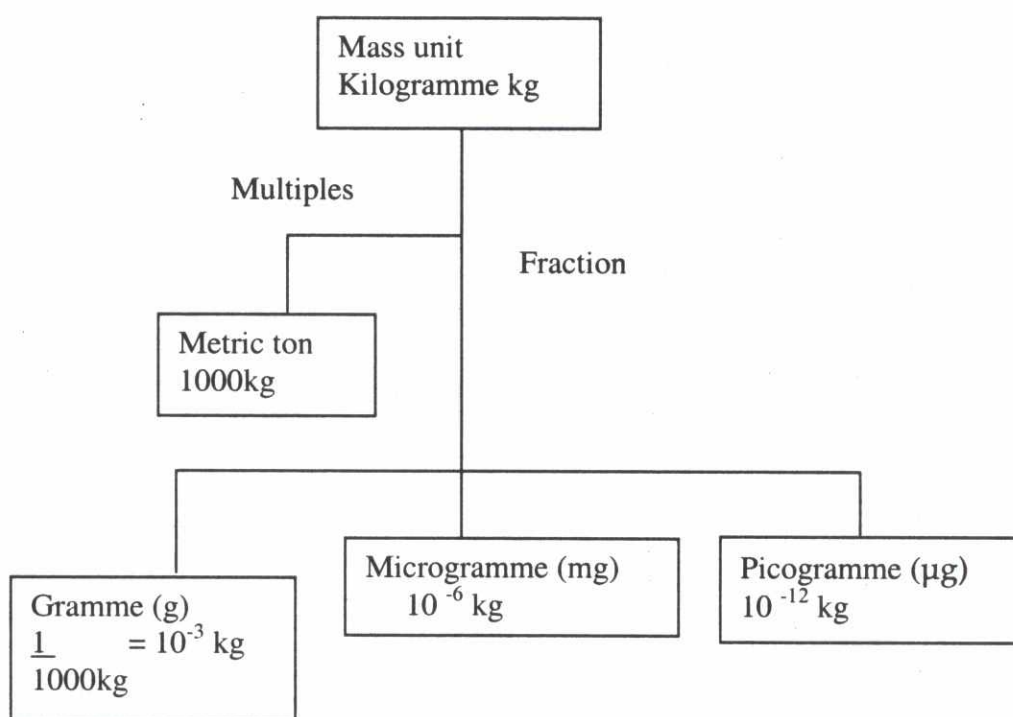

The apparatus used for weighing is called a balance. There are many balances varying in both precision and accuracy. During the course of your program, you will be exposed to such varied balances as analytical balance, balm balance and top – loading balance. Do not be disturbed if you may not have to use any of these balances in this course.

Weighings may have been done for you prior to the laboratory exercise. As you go higher in your programme however, you will definitely make use of a balance yourself.

3.2 Units of Volume (V)

The base unit of measured liquid, which is called volume, is the cubic metre, abbreviated as m^3 . All other units are fractions or multiple of it. The more commonly used ones are cubic decimeter, dm^3 and cubic centimeter, cm^3 . You are also probably aware of such terms as litre, l and millilitre, ml. The relationships between these units of volume are:

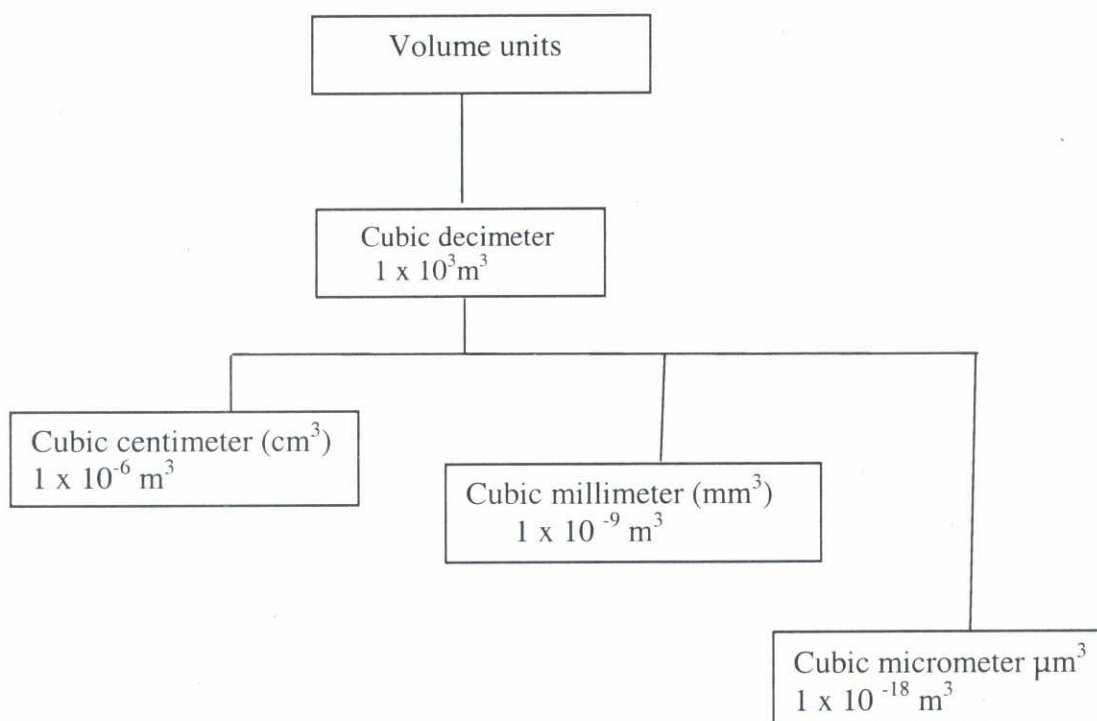

The value equivalent of these units is $1000cm^3 = 1dm^3 = 1 \text{ litre} = 1000ml$.

4.0 Amount of substance

4.1 Concentration

Now that we know, or that we are familiar with weighings and their units, the next thing we should concern ourselves with, is the concentration of a substance

SAQ So what is concentration of a substance?

Answers The term concentration of a substance refers to the amount or quantity of the substance either wholly (e.g. 10g of salt) in relation to another substance (e.g. 10g of salt in water).

However, much as this is explicit enough, in pure chemistry terms, another term called the mole is regarded as the base unit of the quantity or amount of the substance in chemistry. Let us now focus our attention on what a mole is.

4.2 Mole

What therefore is a mole? Why must we express our concentration term in moles? A mole, abbreviated as mol, is the amount of substance, which contains as many elementary units as there are atoms in 12.0g of carbon – 12. These elementary units may be atoms, molecules, ions, electrons etc. in effect we could have one mole of sodium ions, or sodium atoms or one mole ethanol molecules.

The number of such elementary units in a mole of a substance is equal to 6.02×10^{23} particles. This 6.02×10^{23} is called the Avogadro number. We need to express our measured quantity (concentration of a substance) in mole because we have found out that in chemistry, substance react with each other on the bases of **moles equivalent** rather than on amount in grams though this can be worked out if we know the moles.

What we are really saying is that whilst it is true that we can measure in grams (solids) or in cm^3 (liquids). These units must be expressed in the mole unit.

4.2.1 Mole as applied to solid

To do this, let us propose another definition of a mole. The mole of an element or compound is the atomic, ionic, or molecular/ formular mass of the substance expressed in grams (if solid).

That is

$$\text{Mole} = \frac{\text{Mass measure in grams}}{\text{Molar mass in grams per mole}}$$

SAQ1 An undergraduate student used a top loading balance to weigh some quantity of sodium hydroxide. If the weight measure is 10g, express this as mole. (Na = 23, O = 16, H =1).

4.2.2 The mole as applied to solutions

If the weight of the sodium hydroxide weighed above is now dissolved in a definite amount (volume) of water, it may then be necessary to know the concentration of the solution in terms of the number of particles (formula units) present as well as in terms of the mass of solute in the solution.

For these reasons, a number of methods of expressing the amount of solute in solution have been derived and widely used.

This suggests that concentration may be given in more than one way (unit) depending on the units in which the quantity of components or quantity of sample is expressed. For instance, a solution with a relatively small amount of solute is said to be dilute. Another in which large amount or quantity of solute say 200g of NaOH in 1000cm³ of water is said to be a concentrated solution. In effect we can simply express concentration **quantitatively** by calling a solution dilute or concentrated.

We can now redefine concentration as follows: if a sample mixture contains components A₁, A₂, etc then the concentration of component A₁ in the mixture is

$$\frac{\text{Quantity of } A_1 \text{ in the sample}}{\text{Quantity of sample}}$$

A similar equation can be written for any other components in the sample mixture. But more often, the precise concentration terms must be used. That is, solutions must be expressed **quantitatively**, several methods are used.

i. Molarity:

The molarity of a solution is defined as the number of moles of solute in one cubic decimeter (dm^3) or one litre (L) of solution.

$$\text{Molarity} = \frac{\text{Moles of solute}}{\text{Volume of solution in } 1 \text{ dm}^3}$$

Thus, a solution is one molar with respect to a given solute if it contains one mole of that solute in one cubic decimeter (dm^3) of solution.

ii. Molality:

The molality of a solution is defined as the number of moles of solute in one kilogram (kg) of solution.

Let us remind ourselves here of what a molal or indeed 1 molal is:

$$\frac{\text{The weight in grams of a substance}}{\text{Formula weight in grams of the substance}}$$

iii. Normality (N):

Normality is the number of gram – equivalent weight of solute in 1 dm^3 of solution. This term is no longer in use but you will probably encounter it in some chemistry textbooks.

$$\text{Normality} = \frac{\text{Equivalent weight of solute}}{\text{Volume of solution in } \text{dm}^3}$$

SAQ2.

Which is of a higher concentration: a one molar solution or a one molal solution?

4.3 Other units of concentration

Other units of expressing concentration are also encountered in chemistry. This is particularly so when the formula or relative molecular mass of the individual component or a mixture is not known. In these cases it is impossible to use either the molar or molal units. The concentration must therefore be expressed in other units.

i. Percentage of weight (w/w %)

This is defined as the ratio of the weight of solute to the total weight of solute plus solvent multiplied by 100.

$$\text{wt/wt}\% = \frac{\text{wt of solute} \times 100}{\text{wt of solute} + \text{wt of solvent}}$$

ii. Percentage by volume (v/v %)

This is defined as the ratio of the volume of solute to the total volume of solute plus solvent multiplied by 100.

$$\text{Vol / vol}\% = \frac{\text{volume of solute (cm}^3\text{)} \times 100}{\text{Volume of solute} + \text{volume of solvent (cm}^3\text{)}}$$

iii. Percentage weight by volume

This is defined as the number of grams of solute in one hundred (100) cm³ of solution multiplied by 100.

$$\text{Wt / vol}\% = \frac{\text{weight of solute in gram}}{\text{Volume of solutions in cm}^3} \times 100$$

These are the most commonly used ways of expressing concentration in chemistry and specifically in the chemistry laboratory. But there are others such as mole fraction, pH, parts per thousand (ppt), parts per million (ppm), gram per unit volume, specific gravity and volume ratios.

Some of these you will come across in your programme in the chemistry laboratory courses, some you will come across in chemistry texts. It must be stressed that, the units of expressing concentrations of solutions discussed here are thoroughly understood by you.

Understanding them is very basic to understanding this practical chemistry course is all about. It must also be stressed that regardless of concentration unit, the concentration of a solution is better expressed in molarity. This becomes important when we recall that volumes of reacting solutions of the same concentrations bear simple ratios to one another. That is, reactions between reactants to give products occur in mole ratios to one another.

SAQ3. A solution contains 2.65g of anhydrous NaCO_3 in 250cm^3 of solution.

Find the concentrations of the solution in:

- i. Grams per dm^3
- ii. Weight / weight percent
- iii. Weight/ volume percent
- iv. Mol per dm^3

(The formula weight of $\text{Na}_2\text{CO}_3 = 106$, 1cm^3 of water weighs 1g.)

5.0 Standard solution

You will recall that we are now in a position to know the concentration terms of a solution once we know the relative amounts of the solute and the solvent making up the solution. Now let us describe a standard solution.

A standard solution is a solution of which the concentration is accurately known. A standard solution is prepared by weighting a pure solute, dissolve it in a suitable solvent, usually water and make up the solution to a definite volume in a volumetric flask.

6.0 Principle of dilution

It is usual practice in a chemistry laboratory to have a solution of known concentration from which other solutions also of known concentrations can be obtained without reweighing the solute. When this is required, the first solution is usually of higher concentrations than the subsequent solution(s) from which the solutions are derived. That is, the subsequent solutions are of successive lower concentrations and are only obtained from the higher concentration solution by dilution with water.

Whenever a certain volume, V_1 of a solution of concentration C_1 is diluted with pure water to a new volume V , the amount, n , of the substance in the solution remains the same. However the concentration changes by decreasing to C_2 . This exercise is easily understood using this example:

A solution in a bottle is 1.20 molar concentrated. What volume of it must be diluted with water to obtain 600cm^3 of 0.05 molar solution.

Note that I have specifically not mentioned the name of the solution. Whether acid, base, salt, or a specific name whether HCl, NaOH etc. these are not really necessary. What is important is knowing the volume and molar concentrations of the two solutions.

For this example in this assessment question what do we know.

- i. We know the original concentration to be 1.20 mole dm^{-3} . Let us call it C_1 .
- ii. We know the concentration of the new solution we would like to prepare. Lets call it C_2 .
- iii. We know the volume of the new solution we would like to prepare. Lets call it V_2

What we do not know is the volume of the original solution, which we want to dilute. Lets call this V_1 .

Therefore

$$C_1 V_1 = C_2 V_2$$

$$1.2V_1 = 0.05 \times 600$$

$$V_1 = \frac{0.05 \times 600}{1.2} = \frac{300}{1.2}$$

$$= 25\text{cm}^3$$

That is, you will take 25cm^3 of C_1 and add 575cm^3 of water to make 600cm^3 . The new solution will be a 0.05 molar solution.

This particular means of preparing another solution of a different concentration is particularly useful when we are working with acids. This is because acids are naturally provided for us in a solution form in a bottle and it is from this bottle that we take a certain volume which we dilute (or add water) to get our desired concentration. For example, what will be the molar concentration of a solution we would have obtained if we dilute 10.0cm^3 of a solution of conc. H_2SO_4 that is 18.0 molar concentrated?

Using exactly what we did above, we would use

$$C_1 V_1 = C_2 V_2$$

Where 1 is the original solution and 2 is the new solution we are preparing.

Substituting the values therefore $C_1 = 18.0\text{molar}$, $V_1 = 10\text{cm}^3$, $C_2 =$ unknown and $V_2 = 1\text{dm}^3$ (1000cm^3)

$$18 \times 10 = C_2 \times 1000$$

$$C_2 = \frac{180}{1000} = 0.18 \text{ molar}$$

The usual problem encountered by the student is not in calculating the above concentration, but rather in knowing the amount of acid to take that will give the desired concentration on dilution. This has to do with the fact that the actual concentration of the acid may not actually have been provided. Instead you are just given a bottle of the acid and you are told to prepare a certain concentration in a certain volume of water. On the label of the bottle of an acid, certain very important information are usually given.

The label will give the following information: specific gravity; concentration by weight%. Using this two information, you can now calculate the actual concentration of the acid you have been provided with. Let us illustrate this with an example.

The label on a stock bottle of an acid reads: 56% by mass and 1.25 specific gravity. If the molar mass of the acid is 56, find (i) the concentration in grams per dm^3 (ii) the moles per dm^3 (iii) the volume of this acid that is required to prepare 250cm^3 of 1.0 molar concentration of the acid.

- i. The specific gravity means that 1 cm^3 of solution weighs 1.25g or 1000cm^3 (1 dm^3) weighs $1.25 \times 1000\text{g} = 1250\text{g}$.
 Also 56% by weight of the acid means 100g of the acid solution contain 56g of the acid solute.
 Since 1 dm^3 weighs 1250g
 1250g of solution will contain $\frac{56 \times 1250}{100}$ of the acid
 i.e. 1 dm^3 will contain $= 700\text{g}$ of the acid.
 Therefore mass concentration is $700\text{g}/\text{dm}^3$

- ii. The formula mass of the acid is given as 56g.
 Molar concentration $= \frac{\text{mass concentration}}{\text{molar mass}}$
 $= \frac{700\text{gdm}^{-3}}{56\text{gmol}^{-1}}$
 $= 12.5\text{mol dm}^{-3}$

So it has taken us this long to calculate the actual concentration of the acid in the bottle given to us. To find the volume which we shall take out of this bottle to prepare our new solution, we go back to our dilution principle.

- iii. $C_1 V_1 = C_2 V_2$
 Where 1 is the original solution and 2 is the new solution we are preparing.
 Substituting the values therefore, $C_1 = 12.5$
 molar, $V_1 = \text{unknown}$,
 $C_2 = 1.0$ molar and $V_2 = 250\text{cm}^3$

$$12.5 \times V_1 = 1.0 \times 250$$

$$V_1 = \frac{25}{12.5} = 2.0 \text{ cm}^3$$

that is, we take 2 cm^3 of the acid in the bottle, put in a 250 cm^3 volumetric flask and fill it up to mark with distilled water.

7.0 Summary

In this unit, we have discussed the various concentration terms you are likely going to use in the chemistry practical class of this course. We have emphasized particularly the use of mole as means of expressing concentrations of solutions. We also described how you can obtain a solution of another concentration from an already prepared solution by the dilution method.

8.0 Answers to SAQ'S

SAQ1.

$$\text{Mole} = \frac{\text{Mass measure in grams}}{10} = 0.25 \text{ mole}$$

2. A 1 molar solution is of a higher concentration than a 1 molal solution because we would have added more of the solvent (water) in the case of the molal solution than in the case of the molar solution.

$$3. \text{ i) mass concentration} = \frac{\text{mass (g)}}{\text{Volume (dm}^3)} = \frac{2.65 \text{ g}}{\frac{250 \text{ cm}^3}{1000 \text{ dm}^3}} = \frac{2.65}{0.25 \text{ dm}^3} = 10.6 \text{ g dm}^{-3}$$

$$\text{ii) Weight/ weight percent} = \frac{\text{weight of Na}_2\text{CO}_3 \text{ (g)} \times 100}{\text{Weight of Na}_2\text{CO}_3 + \text{weight of water (g)}}$$

$$= \frac{2.65 \text{ g}}{250 \text{ g} + 2.65 \text{ g}} \times 100$$

$$= \frac{265 \text{ g}}{252.65 \text{ g}}$$

$$= 1.05 \text{ (w/w \%)}$$

$$\text{iii) Weight / volume percent} = \frac{\text{weight of Na}_2\text{CO}_3 \text{ (g)} \times 100}{\text{Volume of solution in cm}^3}$$

$$= \frac{2.56\text{g} \times 100}{250\text{cm}^3}$$

$$= 1.06(\text{w/v } \%)$$

iv) Mol per dm^3 or molarity

First find the amount in moles

$$\text{Amount in moles} = \frac{\text{Mass or weight of solute}}{\text{Formular weight}} = \frac{2.65}{106}$$

$$= 0.025 \text{ mole}$$

Then find volume in dm^3

$$\text{Volume (dm}^3\text{)} = \frac{250}{1000} = 0.250\text{dm}^3$$

$$\therefore \text{Moles / dm}^3 \text{ or molarity} = 0.10 \text{ mole / dm}^3$$

9.0 Tutor marked Assignment

1. What is the molar concentration of a solution containing 2.5g of potassium hydroxide in 200cm^3 of solution ($k=39$, $H = 1$, $O =16$).
2. The label on a stock bottle of HCl reads; specific gravity 1.18; 36% by mass of HCl. What volume of this acid is required to make 1dm^3 of 3.0 molar HCl?

10.0 References and other sources

Godwin Ojokuku (1992), Practical Chemistry for Senior Secondary Schools, Revised edn, Gbabeks Publisher Limited, Ibadan, Nigeria.

UNIT 3: UNITS OF MEASUREMENT

1.0 Introduction

In the previous unit, we discussed the various concentration terms that you will likely come across in chemistry practical classes involving quantitative analysis. These concentration terms were discussed in relation to their bearing on solutions. Thus, we now know what a standard solution is and what a stock solution is, infact we discussed how to estimate the concentrations of these solutions. In this unit, we shall go a little bit further by attempting to prepare these solutions.

2.0 Objectives

After going through this unit and performing the experiments set in it, you should be able to:

- Prepare standard solutions of acids and bases
- Estimate the concentration of any prepared solution

3.0 Experiment 1: Preparation of a solution of known concentration and obtaining a diluted solution form the original solution.

3.1 Introduction

In unit 2, we described the underlying concept of use of units in a chemical laboratory operation. In particular is the appropriateness of units applied to weighed substances without which the measurement will be a waste because it will be impossible to interpret and therefore use the result. A main necessity of weighing is to enable a description of the concentration of a solution and be able to define what a solution is.

In this unit, we will discuss the preparation of a standard solution, which we will also regard as a stock solution from which other solutions of different concentrations can be obtained.

3.2 Objectives

After studying this unit, you should be able to:

- i. Use a desiccator
- ii. Use an oven
- iii. Use measure up to mark
- iv. Use a standard volumetric flask
- v. Obtain a solution of lower concentration from a solution of higher concentration
- vi. Prepare a standard solution

Experiment 1A

In this experiment you will learn how to prepare a standard solution of sodium carbonate, Na_2CO_3 .

3.3 Principle

A standard solution of a substance can be prepared if the substance can be obtained in pure state. When a substance is not available in pure form, a solution of approximate concentration is first prepared. This is not a standard solution. To make a standard solution from this, it will have to be standardized, that is, its accurate concentration determined by titrating the solution of approximate concentration against a standard solution of a pure substance.

Why would some substance be obtained in pure form and some substances in an impure form?

A substance which can be obtained in a pure form will be a substance which when, purchased does not change in its chemical composition with time of storage. Such substances will have the following characteristics:

It will be:-

- Of high molar or formula mass
- Easily obtained in a high state of purity
- Anhydrous
- Non – deliquescent
- Non- hygroscopic
- Readily soluble in water or in the required solvent

Such a substance can be used to prepare a standard solution. Such a substance is called a primary standard. Example of such substances are sodium carbonate, Na_2CO_3 (a base), benzoic acid, $\text{C}_6\text{H}_5\text{CO}_2\text{H}$ (an acid). There are some substances which though, are hydrated but do not efflorescences which can also be used in the preparation of a standard solution. Such a substance is called a secondary standard. An example is an acid called oxalic acid ($\text{H}_2\text{C}_2\text{O}_4$).

It is now deductible from the features of primary standards mentioned above, the properties of some compounds which make them unsuitable for use as a primary standard.

These substances cannot be obtained in pure form. They cannot maintain their composition with time. Some may efflorescence, that is loose water of hydration. Some are deliquescent, for example potassium hydroxide, that is, take in only moisture from the atmosphere e.g. H_2SO_4 whilst others cannot just be obtained in high state of purity.

Finally, other are simply volatile liquids and corrosive e.g. HCl and HNO_3 acids and are therefore not suitable as primary standards.

SAQ1 What is a primary Standard? Give two example of primary standard. Why is it not possible to use a solution of sulphuric acid as a primary standard?

3.4 Requirements

Chemicals	Apparatus	Quantity
sodium carbonate Na_2CO_3 previously weighed by your demonstrator	Evaporating dish	1 No
Water	Oven	1 No
	Dessicator	1 No
Sodium hydrogen carbonate (NaHCO_3) to (alternate to sodium carbonate, Na_2CO_3).	Stoppered weighing bottle	1 No
	Beaker 400cm^3	1 No
	Glass rod	1 No
	250cm^3 standard	1 No
	Volumetric flask	
	Glass funnel	1 No
	Wash bottle	1 No
	Funnel stand	1 No
	White tile	1 No

3.5 Procedure

1. Place in an evaporating dish, the previously weighed sample of anhydrous sodium carbonate in an oven for about 10 minutes.. Thereafter, allow to cool in the desiccator.
2. Note the weight of the sample
3. In case, you have sodium hydrogen carbonate instead of sodium carbonate, heat the crystals of sodium hydrogen carbonate to expel water vapour and carbon dioxide according to the equation
$$2\text{NaHCO}_3 \longrightarrow \text{Na}_2\text{CO}_3 + \text{H}_2\text{O} + \text{CO}_2$$

The residue is allowed to cool in a dessicator and weighed. The process of heating, cooling and weighing is repeated until a constant weight is achieved.

4. Weigh accurately a stoppered weighing bottle. Then weigh the sample inside the bottle.
5. Transfer the solid with care into a 400cm^3 beaker containing about 50cm^3 of distilled water. Then wash the stoppered weighing bottle

with distilled water from a wash bottle so that all traces of the solid are transferred in to the beaker. Stir the solution with a glass rod and if necessary, warm to ensure complete dissolution of solid. (Note if you had to warm, allow the solution to cool to room temperature before further work is carried out).

6. The solution is then transferred into a 250cm^3 standard volumetric flask by pouring it down the glass rod through a funnel. The beaker is rinsed several times with water and the washings added into the standard volumetric flask containing the dissolved salt. Shake to make sure that all solid particles are dissolved.
7. Then add more water from the wash bottle to the 250cm^3 mark on the flask. Stopper and further shake to obtain a homogenous solution.

3.6 Observation and Results

- i. Weight of sodium carbonate taken = g.
- ii. Calculation of molar concentration of dissolved Na_2CO_3 .
If x g of Na_2CO_3 was made up to 250cm^3 with distilled water.
Then the amount in moles of Na_2CO_3 in 250cm^3

$$= \frac{\text{weight measured in g}}{\text{Formular mass in g mole}^{-1}} = \frac{x \text{ moles}}{106}$$

$$= Y \text{ moles}$$

Then the amount in moles of Na_2CO_3 in 1dm^3 i.e. molar concentration.

$$= \frac{Y \text{ moles} \times 1000\text{cm}^3}{250\text{cm}^3}$$

$$= 4y \text{ moles dm}^{-3}$$

4.0 Experiments 1B

In this experiment you will learn how to prepare solutions of lower concentrations from the standard solution prepared in experiment 1A.

4.1 Objectives

To respectively prepare a 0.10 molar and 0.05 molar solution of Na_2CO_3 from a 1.00 molar solution of the salt in experiment 1.A.

4.2 Principle

This experiment uses the concept of dilution method to prepare a solution of lower concentration from higher concentration.

It is generally accepted that in the preparations of a series of solutions of the same substance, but of different concentrations, a solution of high concentration is first prepared. This is then diluted with the appropriate solvent to the required predetermined concentration.

For example, if you are to prepare a 1.00molar, 0.10molar, 0.05 molar concentrations of any substance respectively and in this particular case, sodium carbonate, the 1.00 molar concentration is first prepared. Thereafter an appropriate volume of the 1.00 molar solution is then measure using an appropriate measuring device, say a pipette or a burette, into an appropriate standard volumetric flask and then make up the solution to the mark.

SAQ2. Is it practically possible to prepare a solution of high concentration from a solution of lower concentration?

4.4 Requirements

Chemicals	Apparatus	Quantity
A 1.00 molar Na_2CO_3 Previously prepared from experiment 1A	Graduated Pipette	1 No
	Volumetric flasks 250cm^3	2 No
	Dropping Pipette	1 No
Distilled water	wash bottle	1 No

4.5 Procedure

- For the purpose of this experiment, it will be assumed that the solution of Na_2CO_3 , prepared in experiment 1A is 1.00molar.

That is, the value of the grams of the salt in experiment 1A is 26.5g. In effect, we had weighed 26.5g of Na_2CO_3 and dissolved it in 250cm^3 of distilled water in a volumetric flask

- b) For the purpose of this experiment, this standard solution can now be referred to as a stock solution. **A stock solution is a solution of accurately known concentration from which the solutions of lesser concentrations can be obtained.**
- c) This is one of the experiments where you would have done your calculations before starting the experiment, since you are going to prepare a solution. So we shall bring forward the calculation.

Pre – experiment Calculation

If you refer to unit 2, you will be able to recall our example of preparing a 0.05 molar solution from a 1.2 molar solution. The same method of calculation is applicable here.

The stock solution has the following particulars concentration, C_1 which is 1.00 molar; volume V_1 is the value we do not know.

The new solution will have the following particulars concentration C_2 which is 0.10 molar and Volume, V_2 is the capacity of the volumetric flask which in this case is 250cm^3 .

$$\begin{aligned}C_1 V_1 &= C_2 V_2 \\1.0 \times V_1 &= 0.10 \times 250 \\ \therefore V_1 &= \frac{0.10 \times 250}{1.0} = 2.5\text{cm}^3\end{aligned}$$

\therefore You must measure out about 2.5cm^3 of the stock solution.

1. Wash a 20cm^3 graduated pipette with distilled water.
2. Rinse the pipette with about 3cm^3 of the 1.00 molar stock (standard) solution of Na_2CO_3 prepared in experiment 1A.
3. Pipette 2.5cm^3 of the 1.00 molar solution into a clean 250cm^3 volumetric flask.

4. Add distilled water from a wash bottle and then make up the solution to the mark on the volumetric flask with distilled water by use of a dropping pipette.
5. Shake the solutions thoroughly and stopper.

4.6 Exercise

Now take the 0.10 molar solution prepared in experiment 1b above as a stock solution, prepare a 0.05 molar solution.

4.7 Answers

1. (a) A primary standard is a substance that can be used to prepare a solution whose concentration is accurately known.
 - (b) Two examples are sodium carbonate and succinic acid.
 - (c) Sulphuric acid can not be used as a primary standard because:
 - (i) It cannot keep its concentration over a long time due to its volatility.
 - (ii) It is highly corrosive and
 - (iii) It takes in moisture from the atmosphere.
2. It is not practically possible because we will have to remove and reduce some volume of the solvent (water) from the diluted solution. But whilst reducing the water content from a solution is practically possible one may not be able to do this accurately.

UNIT 4 : PREPARATION OF A NON – STANDARD SOLUTION AND STANDARDIZING SAME.

1.0 Introduction

In unit 3, we prepared a standard solution of Na_2CO_3 in a standard volumetric flask, which is also solution of definite concentration because the substance we used, i.e. sodium carbonate is a primary standard. You will recall that in unit 2 not all substances can be used as primary standard substances. Thereafter, we discussed those substances which can not be used as primary standard.

Can you recall these features?

In this unit, we shall describe such solutions and how to prepare them and standardize them that is, determine their accurate concentration.

2.0 Objectives

After going through this unit and performing the experiments in it, you should be able to:

- Prepare a non-standard solution
- Determine the actual concentration of a non-standard solution

Experiment 2

In this unit, you will prepare a solution of approximate concentration and which is thereafter standardise using a standard solution.

3.0 Experiments 2A

3.1 Introduction

In this experiment you will learn how to prepare an approximate 1.0 molar solution of hydrochloric acid.

3.2 Objectives

After going through this unit, you will be able to:

- Prepare a solution of an approximate concentration of substances that are not suitable for use as primary standard.
- Determine the actual concentration of the solution prepared through a standardization method.

3.3 Principle

If you recall experiment 1a where a distinction was made between certain substances whose concentration can accurately be measured and prepared and certain other substances whose concentrations cannot be accurately prepared. These substances whose concentration cannot be accurately prepared are also important and you must therefore be able to prepare them and determine their accurate concentration.

This is done by preparing an approximate concentration and then standardise them, that is, react them, which in practice means titrating them, with a standard solution whose accurate concentration is known.

3.4 Requirements

Chemicals	Apparatus	Quantity	Quantity
Solution of pure concentrated HCl which is 11.6 mol dm^{-3}	Measuring cylinder (10 cm^3)		1No
	Burette (10 cm^3)		1No
Distilled water	Volumetric flask		1No
	Wash bottle		1No

3.5 Procedure

1. Measure accurately 20 cm^3 of pure concentrated HCl by the use of a dry measuring cylinder or a burette. **Caution.** Be careful not to spill the acid on your person or on the bench. Acids are very corrosive and 'eat' anything it comes in contact with. Refer to unit 1 on safety and regulations.

2. Pour the acid into a 250cm³ volumetric flask containing about 100cm³ of distilled water gradually but gently. **Caution.** This method of adding acid to water is the preferred method. Never add water into acid. You could cause an explosion. This is because the dissolution of acid in water is exothermic, that is, it releases (**the beaker becomes hot**) energy which may be so great as to cause an explosion.
3. Shake the mixture and allow the mixture to cool to room temperature.
4. Make up to the 250cm³ mark with more distilled water from the wash bottle. Then, shake thoroughly.
5. Stopper and allow to cool to room temperature.

3.6 Observations and Results

1. As the acid was being gradually added, there was hissing sound accompanied with some observation of colourless vapour.
2. Furthermore, the volumetric flask was getting hotter.

3.7 Treatment of Results

The concentration of the pure HCl used is 11.7 molar. If 20.0cm³ V₁ of 11.7 molar of C₁ of HCl acid is diluted to 250cm³V₂, then the new concentration C₂ will be C₁ V₁ = C₂ V₂

$$\begin{aligned}
 11.7 \times 20\text{cm}^3 &= C_2 \times 250\text{cm}^3 \\
 C_2 &= 11.7 \times 20 \text{ moles dm}^{-3} \\
 &= 0.936 \text{ moles dm}^{-3}
 \end{aligned}$$

3.8 Exercise

- Did I hear you say that it is similar to did in experiment 1B?
- Did I hear you say that the concentration of 0.936 moles dm⁻³ we obtained is not the 1.0 molar solution we set out to prepare?

To answer the first question, yes, the method of arriving at our concentration C_2 is the same method we used in experiment 1B. That is, it is purely a dilution process. This will tell you that all liquid solutions can be so treated.

In answering the second question, yes the concentration is not up to the 1.0 molar solution we set out to prepare. But didn't I say we can only prepare an approximate concentration when we use certain substance such as HCl ?

To now know the accurate concentration of the HCl prepared, we will have to perform the standardisation process.

Note it will be improper but not impracticable to regard this solution as a stock solution because its actual concentration from which subsequent solutions can be obtained is not known.

4.0 Experiment 2B

4.1 Introduction

Standardisation of an approximate 1.0 molar solution of hydrochloric acid with standard solution of 0.5M Na_2CO_3 solution.

4.2 Objectives

After doing this experiment you will be able to do a titration experiment to determine the actual concentration of a solution using a standard solution.

4.3 Requirement

Chemicals	Apparatus	Quantity	Quantity
Solution of Na_2CO_3 prepared in experiment 1A	Pipette	25cm ³	1No
	Burette	50cm ³	1No
Solution of HCl prepared in experiment 2B	Glass funnel		1No
	Conical flask	250cm ³	
	White tile or white		
Methyl orange indicator	Sheet of paper, clamp		1No

4.4 Procedure

1. Put up a clamp with the 50cm³ capacity burette. Rinse the burette with the solution of the acid.
2. Fill the burette with the acid solution with the aid of a glass funnel. Fill it more than the 50cm³ mark, remove the funnel and release the tap of the burette such that some of the solution will drop out into a waste beaker. Stop the release when the liquid reaches the 50cm³ mark, this will expel any air bubble trapped within the body of the liquid
3. Rinse the pipette with the 0.5 molar Na₂CO₃ solution. Pipette out 25cm³ of the solution from the volumetric flask into a clean 250cm³ conical flask. Add two or three drops of the methyl orange indicator. Place the conical flask containing the Na₂CO₃ solution on the white tile or sheet of paper.
4. Run the acid from the burette into the base until the colour of the solution changes to pink.
5. Record the reading of the burette
6. Repeat steps 2, 3, 4, and 5 two more times.
7. Prepare a table as shown in section 4.5 of this unit and find the average volume of the acid used in the titration.

4.5 Results

The values used here are hypothetical			
Burette Reading	1st Titration	2nd Titration	3rd Titration
Initial reading	0.00cm ³	0.00cm ³	0.00cm ³
Final reading	24.60cm ³	24.40	24.40
Volume of acid	24.60cm³	24.40cm³	24.40cm³

$$\begin{aligned}\text{The average volume of the acid used} &= \frac{24.40 + 24.40}{2} \\ &= 24.40\text{cm}^3\end{aligned}$$

4.6 Treatment of Results

You are carrying out this calculation without previous introduction on problem solving. I would suggest you note the method of calculation for now. More detailed explanation would be given in the next unit.

Equation of the Reaction

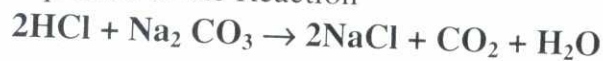

From the equation, 2 moles of HCl react with 1 mole of Na_2CO_3 .

Using the formula you are familiar with

$$\frac{C_A V_A}{C_B V_B} = \frac{n_A}{n_B} \text{ where}$$

C_A	=	Concentration	= unknown
V_A	=	Volume of the acid obtained from titration	= 24.40cm^3
C_B	=	Concentration of the Na_2CO_3	= 0.5mol dm^{-3}
V_B	=	Volume of the Na_2CO_3	= 25cm^3
n_A	=	No. of moles of acid from the balanced equation	
n_B	=	No. of moles of Na_2CO_3 from the balanced equation	

$$\therefore \frac{C_A \times 24.40}{0.5 \times 25} = \frac{2}{1}$$

$$C_A = \frac{0.5 \times 25 \times 2}{24.40} = \frac{25\text{mol dm}^{-3}}{24.40} = 1.03\text{mol dm}^{-3}$$

5.0 Conclusion

The actual concentration of the solution of HCl prepared is 1.03mol dm^{-3} and not 0.096mol dm^{-3} we thought we prepared from the dilution process.

6 Summary

We have just determined the actual concentration of an acid solution we could not exactly define before this experiment. This experiment demonstrates the process of standardisation.

UNIT 5: VOLUMETRIC ANALYSIS

1.0 Introduction

Two important goals of chemical analysis in chemistry are:

1. The determination of what the constituents in a sample are and
2. The determination of how much of each constituent is in a sample.

The first is called qualitative analysis and embraces essentially the detection of elemental ions and functional groups in a single compound, we will come across this in the next course.

The second is called quantitative analysis, determines the amount of the elements or compounds present in a sample. There are definite techniques useful for this type of analysis, such as gravimetric analysis, volumetric analysis and instrumental analysis.

In this unit we shall restrict our discussion to only volumetric analysis.

Volumetric methods of analysis are comprised of techniques in which the volume of a gas is measured or the volume of a solution of known concentration is measured. The latter technique is known as titrimetric analysis. Titrimetric analysis consists of titration. Titration is the procedure by which a solution of known concentration is added to another solution until the chemical reaction between the two solutes is complete.

The solution whose concentration is known is called the standard solution or the titrant. In titration the standard solution (titrant) is slowly added from a burette to a solution, which contains a known mass of solute. The latter solution is commonly referred to as the unknown.

The point at which stoichiometrically equivalent quantities of substances have been brought together is known as the equivalence point of titration. This point signifies when the reaction must have come to completion.

Thus, in the process of titrating an unknown solution with a standard solution, there must be some way to determine when the equivalence point of the titration has been reached. This is because, in most of the cases, the two solutions being titrated against each other are colorless and determining the equivalence point will be a guessing game and thereby introduce error. To avert such inappropriateness, the end of the equivalence point is usually done by using what is called an indicator.

The indicator in most cases is an organic substance (a dye) which changes color or gives some other obvious physiochemical change in the titrated solution when an amount of the standard solution (titrant) added is equivalent, or with negligible error, almost equivalent to the sample. The moment at which the indicator changes the color of the titrated solution is called the end point of the titration.

In other words – the experimentally determined position of the stoichiometric point of the titration is called the end point, while the actual theoretical stoichiometric point of the titration is the equivalence point. A successful titration, a titration with good quantitative results, is possible only if the end point as established by the indicator occurs at the equivalence point of the titration.

There are four types of titrimetric analysis each of which is based on certain type of reaction i.e.

- a) Acid – Base titration
- b) Oxidation – Reduction Titration
- c) Precipitation Titration
- d) Complexometric Titration

And there are three different techniques for determination of an unknown sample in titrimetric analysis.

- a) **Direct titration** – When standard solution directly reacts with the substance being determined.
- b) **Back titration** – An accurately measured amount of one standard solution is added to the sample, in excess of the

stoichiometric amount of the substance to be determined in the sample, then unreacted excess is titrated with another standard solution. For this type of titration two standard solutions are needed.

- c) **Indirect titration** – When standard solution does not react with the substance being determined, but instead with another substance that is produced in the sample in equivalent amount of the determined substance.

In the following units, we shall concentrate on acid – base titration and on oxidation – reduction titration. The others – precipitation and complexometric titrations shall be taken up in the higher course during the course of your programme.

In addition to the three techniques, we shall concern ourselves with direct and back titrations. I shall defer the treatment of indirect titration to next higher course in practical chemistry.

3.0 Acid – base Titration

3.1 Introduction

Acid base titration involves a neutralization reaction. In this titration, acids are determined by titration with an appropriate base solution. Conversely, bases are determined by titration with an appropriate acid solution.

As you can recall from experiments 1 and 2 in the previous units, two types of solutions can be prepared from either the acidic or basic groups. These are primary standards prepared from substance whose purity and properties have been exactly known and verified.

The other group consists of substances whose purity cannot be exactly known due to a number of reasons: they are highly hygroscopic; they react with CO_2 in air or moisture in air or because they are volatile. To determine the concentration of such solutions, the approximately measured concentrated solution is titrated against a primary standard solution. This procedure as we discovered in experiment 2 unit 4 is referred to as standardisation

Let us refresh our memory concerning standardization. Standardisation usually involves:

- Preparation of primary standard solution (titrant solution).
- Preparation of a solution of approximate concentration to be standardized.
- Titration – the process during which the exact concentration of solution is determined.
- Calculation of the result from data obtained in titration .

In the titration process, one solution, usually the standard, is slowly added from the burette to another solution placed usually in a conical flask that contains a known volume or known mass of solute, until the chemical reaction between the reactants is complete.

3.2 Indicators

The point at which stoichiometrically equivalent quantities of substances have been brought together is known as equivalence point of titration. To determine when the equivalence point of titration is reached, an indicator is used. In acid base titrations, the indicators such as methyl orange, phenolphthalein and bromothymol blue which are usually organic dyes that change colour according to the hydrogen ion concentration of the solution or liquid to which they added or found themselves, are used.

For example, phenophtalein is an indicator that is colorless in acidic solution but changed to pink in basic solution.

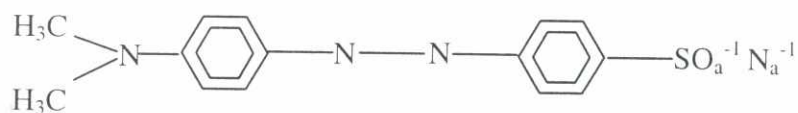

Methyl orange (yellow form)

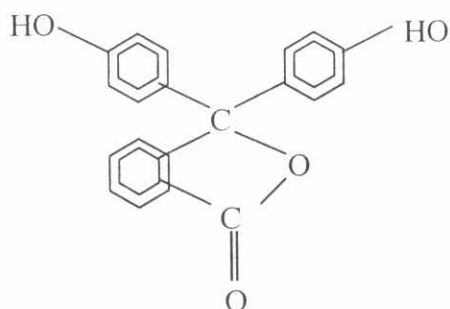

Phenolphthalein (Colourless form)

These indicators can be regarded as weak acids of which either the undissociated molecule or the dissociated anion, or both are coloured. If we take methyl orange for example,

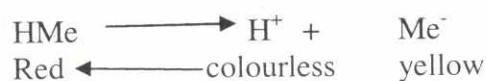

Addition of acid moves the equilibrium to the left so that the solution becomes red. Conversely, when alkali containing hydroxyl ions are added, equilibrium moves to the right and the colour becomes yellow. It is also said that it is rarely possible to find an indicator that will indicate exact equivalence point, hence the change in colour we observe when we stop the titration indicates the end of the titration. Although the end point of titration does not coincide with the equivalence point, the error is negligible.

The table below shows the list of indicators commonly used in acid – base titration, the colours they exhibit in various solutions and the pH range where colour changes take place.

3.2.1 pH Scale

The pH of a solution (or a liquid) is a measure of the hydrogen ion, H^+ , concentration in the solution. The pH scale ranges from 0 to 14. A solution with pH value less than 7 is acidic; exactly 7 is neutral, while the higher the value, the more alkaline the solution. Pure water has a pH of 7, it is neutral.

When the colour of an indicator changes, it is due to the acidity of the change in the environment it has found itself. Near the end – point, both coloured forms will be present in appreciable quantities.

INDICATOR	COLOR in			pH RANGE
	Acid	Neutral	ALKALI	
1. Litmus	Red	Purple	Blue	6.0 – 8.0
2. Methylorange	Pink	Orange	Yellow	3.1 – 4.4
3. Phenolphthalein	Colorless	Colorless	Pink	8.3- 10.0
4. Bromothymol	Yellow	Blue	Blue	6.5 – 7.8

3.2.2 Choice of Indicator in Acid – base Titrations

The choice of an indicator in an acid – base titration depends on the strengths (strong or weak) of the acid and base. The classification of the strengths of common acids and bases (alkali) is shown in the table below:

Strength of Acid		Strength of Base	
STRONG	WEAK	STRONG	WEAK
H ₂ SO ₄ ; HCl; HNO ₃	CH ₃ COOH; H ₂ C ₂ O ₄ ; H ₂ SO ₃	NaOH; KOH	Na ₂ CO ₃ ; aqNH ₃

Types of Acid – Base titrations and the choice of indicator.

Acid –Base Titration	Example	pH of solution end - point	Suitable Indicator
Strong acid vs strong base	HCl vs NaOH	7	Any indicator:
Strong acid vs weak base	H ₂ SO ₄ vs aqNH ₃	5 - 6	Methylorange
Weak vs strong base	COOH vs NaOH	8 – 9	Phenolphthalein
Weak acid vs weak base	CH ₃ COOH vs aq NH ₃	variable	No suitable Indicator

3.2.3 Wrong use of indicator

The accuracy of a titration depends on the use of the correct indicator. Wrong choice of indicator will lead to wrong result. For instance, in the titration of a solution of a strong acid (HCl) with that of a weak base (Na₂CO₃), methyl orange should be used. If Phenolphthalein is used

instead, the end point will appear when only half of the weak base, Na_2CO_3 has been used up, as shown in the following reactions.



The reason is that Phenolphthalein is sensitive to weak acid such as NaHCO_3 . The table can easily be explained. For instance if you add say methyl orange indicator the colour you will notice is yellow. As you run in the acid from the burette, the neutralisation reaction occurs. The colour in the conical flask will still be orange until complete neutralisation when there is stoichiometric equivalence of the acid and base.

The next drop of acid into the conical flask will not have a base to react with. Therefore there will be an extra drop of acid. At the point, the colour in the flask will now have to change because the indicator now finds itself in a new environment i.e. acidic environment. In the particular case of methyl orange, the color will now change to pink thus marking the end point.

SAQ1

1. Can you think of which indicator you would use when a strong acid is titrated against a weak base?
2. State the colour of the indicator before the end point and after the end point.

3.3 Problem Solving in Acid – base titration

How can the amount of substance be determined in a titrimetric analysis? Can you remember how we calculated the concentration of the hydrochloric acid solution in experiment 2b. Go back and study the calculation.

To fully understand the principle of the calculation, a thorough knowledge of the following is required:

- You must be able to write a balanced chemical equation of the reaction.
- From the balanced chemical equation, you must derive the stoichiometric mole equivalent ratio of the reactants.
- From the above, you must be able to utilize the full applications of the mole concept to arrive at the molar concentration terms.

3.3.1 Writing balanced chemical equation

The ability to write a balanced chemical equation is derived from having the full knowledge of the formula (e) of elements, molecules and compounds as a result of their respective valence. This ability, I believe you must have acquired before embarking on this programme. If you are however unsure of yourself, I will refer you to any standard textbook in chemistry at the senior secondary school level. Put briefly, the coefficients of the molecules, compounds taking part in the neutralisation reaction must be accurately determined so that

- Matter will neither have been created or destroyed
- You will have no inequality in the mass balance between the reactants and products.

SAQ 2

Write balanced chemical equations for the following acid- base reactions and indicate the stoichiometric mole ratio between the reactants.

- A reaction involving a solution of sodium hydroxide and a solution of hydrochloric acid.
- A reaction involving a solution of sodium hydroxide and a solution of sulphuric acid.
- A reaction involving a solution of sodium carbonate and a solution of hydrogen chloride.
- A reaction involving a solution of hydrated oxalic acid solution $\text{H}_2\text{C}_2\text{O}_4 \cdot 2\text{H}_2\text{O}$ and a solution of sodium hydroxide.

3.3.2 Calculation of molar concentration

If you remember what I said when we calculated the accurate concentration of the hydrochloric acid in experiment 2B. There, no explanation was given to the procedure used in arriving at the solution.

The formula or method of calculation we used in that particular problem should be well known to you from your SSCE experience. Although it is still acceptable and correct to use this method, it does not provide a full understanding of how to solve quantitative acid- base problems in chemistry.

Let us now go through the proper procedure for calculation using the mole concept.

- Can you remember the definition of a mole?
- Can you remember the formula derivation of the mole for a solid substance?
- What about the formula derivation of the mole for a solution?

The answers to these posers can be found in unit 2. Put briefly, a mole is the amount of the substance equivalent to the Avogadro number in amount of the substance. It is also the mass of the substance divided by the formula mass of the substance. But let us demonstrate this mole concept by solving appropriately the problem encountered in experiment 2B. The facts for that experiment as presented are:

- i. A standard solution of sodium carbonate was supplied with the following characteristics. The concentration of sodium carbonate was given as 0.5mol dm^{-3} (molar). The volume of sodium carbonate employed for the titration was 25.0cm^3 .
- ii. The actual concentration of the HCl was not known but the volume of the acid consumed in the titration was found to be 24.40cm^3 .

Now let us find the concentration of the HCl. The following steps may be followed.

- i. First write a balanced equation for the reaction



- ii. Then state the stoichiometric mole ratio
2 moles HCl react with 1 mole Na_2CO_3
- iii. Determine the amount in moles of the reactant whose volume and concentration are known. In this case, it is the Na_2CO_3 solution

$$\text{Amount in moles} = \frac{\text{Mass}}{\text{Molar mass}} \quad \text{or}$$

$$\begin{aligned} \text{Amount in mole} &= \frac{\text{Concentration in } \text{mol dm}^{-3} \times \text{volume } \text{cm}^3}{1000\text{cm}^3} \\ &= \frac{0.5 \times 25}{1000} \\ &= 0.0125 \text{ moles} \end{aligned}$$

This amount in moles we have determined is contained in the 25cm^3 of Na_2CO_3 that completely reacted with the acid.

- iv. Determine the equivalent amount in moles of the acid with the Na_2CO_3 .

Since from the stoichiometric balanced chemical equation, 1 mole $\text{Na}_2\text{CO}_3 = 2\text{moles HCl}$, therefore 0.0125 moles Na_2CO_3 will, have reacted with 0.025 moles HCl.
($2 \times 0.0125\text{moles}$).

This amount in moles of the acid we have determined we should remind ourselves is contained in the 24.40cm^3 of acid that reacted with the base.

- v. Finally we will determine the molar concentration of the acid

$$\text{Molar concentration} = \frac{\text{amount in mole} \times 1000\text{cm}^3}{\text{Volume}}$$

$$= \frac{0.025 \times 1000}{24.40} \\ = 1.03 \text{ mol dm}^{-3}$$

Which is exactly the same answer we got earlier.

You will observe that this method is longer than the earlier one but you will also agree it provides a better understanding of the calculation method in volumetric analysis. I recommend this method of calculation from now on.

4.0 Conclusion

In this unit, we have been introduced into acid – base titration and how to estimate the concentration of the reactants using the mole concept. We were also introduced to the difference between an end – point and an equivalence point and the use of an indicator to mark the end of one but the observance of the other.

5.0 Answers to SAQ's

1. Methyl orange indicator; colour will change from yellow to pink

2. i) $\text{NaOH} + \text{HCl} \longrightarrow \text{NaCl} + \text{H}_2\text{O}$
1 mole NaOH (is equivalent to) = 1 mole HCl

ii) $2\text{NaOH} + \text{H}_2\text{SO}_4 \longrightarrow \text{Na}_2\text{SO}_4 + 2\text{H}_2\text{O}$
2 moles NaOH = 1 mole H_2SO_4

iii) $\text{Na}_2\text{CO}_3 + 2\text{HCl} \longrightarrow 2\text{NaCl} + \text{H}_2\text{O} + \text{CO}_2$
1 mole Na_2CO_3 = 2 moles HCl

v) $2\text{NaOH} + \text{H}_2\text{C}_2\text{O}_4 \cdot 2\text{H}_2\text{O} \longrightarrow \text{Na}_2\text{C}_2\text{O}_4 + 4\text{H}_2\text{O}$
2 moles $\text{H}_2\text{C}_2\text{O}_4 \cdot 2\text{H}_2\text{O} \longrightarrow$

6.0 References and Other Resources

C.Ikoku, M.Ahmed and Emma Joju, Laboratory Exercise in Chemistry.
Forth Dimensions publishers, 1985

UNIT 6: ACID – BASE II STANDARDISATION OF A NON-STANDARD SOLUTION

1.0 Introduction

Try and remind yourself why the concentrations of HCl could not have been accurately known. In the previous experiments, we were able to determine the actual concentration of the acid solution, HCl, whose concentration was approximately measured. This we did by standardising the HCl solution with a primary standard solution of Na_2CO_3 . Having already now determined the exact concentration of the HCl, you can now use it to standardise another base e.g. NaOH whose solution also cannot be used as primary standard.

SAQ 1. Why can't sodium hydroxide be used as a primary standard?

2.0 Objectives

After the completion of this unit, you will be able to:-

- Use a pipette
- Use a Burette
- Do a titration correctly
- Calculate the concentrations of solution from titration data.
- Appreciate the use of standardised solution to standardise another solution.

3.0 Experiment

3.1 Requirements

In addition to the requirement listed in previous titration experiments, there is (i) a NaOH solution already prepared for you by the laboratory technologist (ii) a 500cm^3 volumetric flask.

3.2 Procedure

1. Take 10cm^3 of the 5M NaOH solution into a 500cm^3 volumetric flask. Dilute the portion 50 times with distilled water and mix the solution thoroughly to make it uniform.
2. Transfer accurately, using a pipette, 25cm^3 of your now standard 0.103 molar solution of hydrochloric acid to a conical flask.
3. Place the conical flask on the white sheet or tile and add two to three drops of methyl orange indicator.
4. Pour the solution of NaOH into the burette, run off to the zero mark to expel air bubble.
5. Titrate the solution of NaOH with HCl to the first permanent yellow colouration.
6. Repeat the titration using fresh portions of HCl ; unit at last two titration are within the accuracy of 0.2cm^3 of the titrant.
7. Find the average of the titre values.

3.3 Results

Titration	1 st titration	2 nd titration	3 rd titration
Final burette reading			
Initial burette reading			
Volume of NaOH used			

$$\text{Average titre reading} = \frac{\quad}{3} = 19.70\text{cm}^3(\text{assuming})$$

Your titre value will be different from the value of 19.70cm^3 we are using here. I am going to use it to illustrate the sort of calculations encountered in titrimetric analysis. So please use your own value where appropriate. This is because the concentration of the NaOH and HCl provided by the laboratory will certainly be different from mine. As we did in the last

calculation, we will write down the variables needed to solve our problems and then follow the steps.

Concentrations of the acid	=	0.103 moldm ⁻³
Volume of the acid	=	25cm ³
Concentration of NaOH	=	Unknown
Volume of the NaOH consumed	=	19.70cm ³ (assumed)

Now to the calculation

Step 1: Write a balanced chemical equation



Step 2: State stoichiometric mole equivalent of the reactants
1 mole NaOH = 1 mole HCl

Step 3: Determine the amount in moles of the reactant whose volume and concentration values are known which in this case is HCl

$$\begin{aligned}\text{Amount in moles HCl} &= \frac{\text{Concentration} \times \text{volume used}}{1000} \\ &= \frac{0.103 \times 25}{1000} \\ &= 0.00258 \text{ moles}\end{aligned}$$

This amount, 0.00258 moles is contained in the 25cm³ of HCl used in the titration

Step 4: Determine the equivalent amount in moles of the NaOH with the HCl since from stoichiometry.

$$\begin{aligned}1 \text{ mole HCl} &= 1 \text{ mole NaOH} \\ \therefore 0.00258 \text{ moles HCl} &= 0.00258 \text{ moles NaOH}\end{aligned}$$

This amount 0.00258 moles is contained in the 19.70cm³ of NaOH that reacted with the HCl.

Step 5: Determine the molar concentration of the base

$$\begin{aligned}\text{Molar concentration} &= \frac{\text{amount in moles} \times 1000}{\text{Volume}} \\ &= \frac{0.002568 \times 1000}{19.70} \\ &= 0.131 \text{ moldm}^{-3}\end{aligned}$$

4.0 Conclusion

The calculations done in this unit has exposed us to the fact that a non standard solution whose concentration was accurately determined by titrating it with a primary standard can be used to also determine the actual concentration of another non standard solution. The sequence can go on and on.

5.0 Answers

1. NaOH can not be used as a primary standard because, it absorbs moisture from the atmosphere. Therefore, its concentration cannot be guaranteed with time of storage.

UNIT 7: ACID – BASE III DETERMINATION OF PERCENT PURITY OF A SUBSTANCE

1.0 Introduction

The previous experiments in acid - base titrations had exposed us to the laboratory skills required to successfully titrate an acid against a base. We have also learnt how to calculate the volume and molar concentrations of either of the reactants. In particular we are fully aware of the standardisation procedure required to know the actual concentration of a solution whose concentration is not accurately known.

However, acid – base titrations provide more applications than this. We can also use titrimetric analysis to determine other parameters such as the percentage purity of a substance. Sometimes, one of the substances used in the titrations may be impure. This impurity may be due to improper preparations of the substance e.g. presence of water of crystallization or contamination by one of its salts e.g. contamination of NaOH by NaCl.

In any of these cases however, the neutralization reaction will only occur between the pure component of the impure substance and the pure titrant. That is, the impurity will remain in solution. In the specific cases mentioned above, the contaminant, NaCl and the water of crystallization will remain in solution whilst the pure NaOH will react with the titrant.

SAQ1

Which is greater? The mass of an impure substance or that of pure component of the impure substance to complete a neutralization reaction?

2.0 Objectives

After going through this experiment, you should be able to:-

- Estimate the percentage purity or impurity of a substance.
- Estimate the relative molecular mass of the pure substance

3.0 Experiment

Determination of the percentage purity of a substance

3.1 Requirements

Chemicals	Apparatus	Quantity
Solution of impure sulphuric acid containing 4.50g of H_2SO_4 in 250cm^3	Those listed in experiment 2	
Solution of impure base B, NaOH from last experiment containing 5.24g per dm^3		
Methyl orange indicator		

3.2 Procedure

1. Rinse a burette twice with a few drops of solution A and next fill it with same solution above the zero mark. Drain to the marking, making sure the burette is full.
2. Using a pipette, transfer 20cm^3 of solution B into a conical flask. Add two to three drops of methyl orange. Place the conical flask onto a white sheet of paper or tile.
3. Run solution A to the conical flask whilst shaking vigorously until a permanent faint pink colouration is observed.
4. Repeat the titration using fresh portions of solution B until at least two titrations are within the accuracy of 2.2cm^3 of the titrant.
5. Find the average of the titre values.

Problem.

From your average titre value, determine

- The molar concentration of solution B
- The amount in moles of solution A
- The molar concentration of solution A
- The mass concentration of the pure acid in solution A in grams per dm^3
- The percentage impurity of the solution A
- Name another indicator that might be suitable for this reaction and what would be the colour at the end point.
(Na = 23, O = 16, H = 1, S = 32)

3.3 Results

Titration result	1 st titration	2 nd titration	3 rd titration
Final burette reading			
Initial burette reading			
Volume of NaOH used			

$$\text{Average titre reading} = \frac{\quad + \quad + \quad}{3} = 22.50\text{cm}^3 \text{ (assuming)}$$

34 Treatment of Results

This is the first in a series of actual practical test. The workings have been provided to enable you further understand the steps involved in the calculation.

Note that: the titre value I have used may be different from the titre value you actually obtain.

The balanced chemical equation is

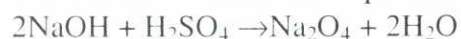

The mass concentration of solution B = 5.24 g dm^{-3}
Molar mass of NaOH = 40.0 g mol^{-1}

$$\therefore \text{ a) Molar conc. of solution B} = \frac{\text{mass}}{\text{molar mass}} = \frac{5.24 \text{ g dm}^{-3}}{40 \text{ g mol}^{-1}} = 0.131 \text{ mol dm}^{-3}$$

- b) The amount in moles of solution A.
First, we find the amount in moles of B = molar conc. X volume

$$= \frac{0.131 \text{ mol dm}^{-3} \times 20 \text{ dm}^3}{1000} = 0.0026 \text{ mole}$$

From stoichiometry

$$\begin{aligned} 2 \text{ moles of B} &= 1 \text{ mole of A} \\ \therefore 0.0026 \text{ moles of B} &= \frac{1}{2} (0.0026 \text{ moles of A}) \\ &= 0.0013 \text{ moles of A} \end{aligned}$$

- c) The molar concentration of A
= 0.0013 moles of A is contained in say, 22.50 cm^3
 $\therefore 1000 \text{ cm}^3$ will contain $\frac{0.0013 \times 1000}{22.50}$
= $0.058 \text{ moles dm}^{-3}$

- d) The mass concentration of the pure acid in grams per dm^3 molar
mass $\text{H}_2\text{SO}_4 = 2 + 32 + 64 = 98.0$ per mole
 \therefore mass concentration = $0.0058 \times 98 = 5.706 \text{ g dm}^{-3}$

- e) The percentage impurity of solution A
we must find the concentration of the original impure acid in g/dm^3 . We were provided with 4.50 g in 250 cm^3
 250 cm^3 of solution A contains 4.50 g
 $\therefore 1000 \text{ cm}^3$ (1 dm^3) will contain $\frac{4.50 \times 1000 \text{ g dm}^{-3}}{250}$

$$\begin{aligned} \therefore \text{ The concentration in } \text{g dm}^{-3} &= 18.0 \text{ g dm}^{-3} \\ \text{But the mass of solution A obtained from the titration is } &5.706 \text{ g dm}^{-3} \\ \text{Mass of the impurity} &= 18.0 - 5.7 \\ &= 12.3 \text{ g dm}^{-3} \end{aligned}$$

$$\begin{aligned}\text{The percent impurity} &= \frac{\text{mass of impurity} \times 100}{\text{mass of impure acid}} \\ &= \frac{12.3}{18.0} \times 100 \\ &= 68.33\%\end{aligned}$$

That is, **solution A is 68.33% impure.**

- f) This question was asked to enable you choose indicators in unit 5 and to make you aware that there could be other suitable indicators.

∴ Another suitable indicator is phenolphthalein indicator and the colour at the end point is colourless.

4.0 Conclusion

This experiment has demonstrated one of the most important application of volumetric analysis useful in the industry. The determination of percent purity of a substance is a quantitative method of ascertaining how pure the substance in question is as a preliminary investigation of the quality of the substance.

5.0 Answers to SAQ

1. The weight of an impure substance is usually greater than that of pure component because you will actually need more of the impure substance to complete the same reaction a pure component would require.

UNI 8: ACID – BASE IV DETERMINATION OF CONCENTRATION OF A SUBSTANCE IN EXCESS (BACK TITRATION)

1.0 Introduction

I want you to refer to unit 5 and the section under volumetric analysis. In particular, the subsection where the three different techniques for determination of an unknown sample was discussed in titimetric analysis.

In the previous units 5, 6 and 7, we had concerned our experiments to the techniques of direct titration. That is, where a standard solution directly reacts with the substance being determined.

In this unit, we shall provide only one experiment, to demonstrate another of the techniques which is popularly referred to as Back – Titration. This is obtained when in an acid – base reaction, the amount of base added to a certain amount of the acid is in excess of the stoichmetric amount of the acid required leaving the base in excess and the resulting solution basic.(If it is the acid that is excess, the remaining solution will be acidic).

The amount of base in excess can now be determined by titrating the excess basic solution against another standard acid solution different from the initial acid that reacted with the base.

2.0 Objectives

After going through this unit, you should be able to:-

1. Understand the stoichiometric equivalence of reactants
2. Estimate the amount of reactant that is in excess.

SAQ1

What would be the pH of the resulting solution of the mixture where the amount of acid added to the base is more than the actual amount required to complete neutralization.

3.0 Experiment

ACID – BASE TITRATION IV. Determination of the concentration of a substance that is in excess after a chemical reaction (back titration).

3.1 Requirements

Chemicals	Apparatus	Quantity
Sample A is a solid anhydrous sodium carbonate	As listed in experiment 2	
Sample B is a standardisation solution of HCl containing 0.303 mole/dm ³	1 litre standard flask	1No
Sample C is a standardised solution of NaOH containing 0.131 mole/ dm ³	Tripod stand	
Phenolphthalein indicator	Bunsen burner	

3.2 Procedure

1. 1000cm³ of solution B was put into a one litre (dm³) standard flask
2. Pour into the solution, all of the Na₂CO₃ sample
3. Mix thoroughly. Warm gently if necessary. You may notice slight bubble. Allow to cool if warming was performed.

4. Rinse a burette twice with a few cm^3 of solution C and next fill it with the same solution above the zero mark and drain to the mark making sure the burette tip is full.
5. Using a pipette, transfer 25cm^3 of the solution B into a 250cm^3 conical flask. Add two to three drops. Place the conical flask onto a white sheet of paper or tile.
6. Run solution C into solution B in the conical flask whilst swirling the flask to ensure adequate mixing of the content until a permanent pink colouration is observed.
7. Repeat the titration using fresh portions of solution B until at least two titration values are within the accuracy of 0.2cm^3 of the titrant.
8. Find the average of your titre values.

Problem

From your average titre value, determine

- a) The concentration in moles per dm^3 of solution C that has reacted with solution B
- b) The mass of solid sample A in grams that was dissolved in solution B (Na = 23, O = 16, H = 1)

3.3 Results

Burette reading	1 st Reading	2 nd Titration	3 rd Titration
Final reading			
Initial reading			
Volume of solution C			

$$\text{Average titre reading} = \frac{+ +}{3} = 22.50\text{cm}^3 \text{ (assuming)}$$

3.4 Treatment of results

In solving this problem, you must understand that when sample A, was added to solution B, HCl.

The reaction is represented by



Thereafter when solution C containing NaOH was now titrated against solution B, the reaction must have been with the excess amount of the HCl i.e. Back titration. The reaction can be represented by



Since there was no evidence of the first reaction, it is only the second reaction that can be used to determine the amount of the first reactant. You may wish to note also that, the average titre value that will be used in solving this problem may not coincide with the titre value you obtained in the laboratory. This is just a demonstration.

We shall begin from the titre value

The amount in moles of NaOH

$$= \text{Molar concentration} \times \text{Volume}$$

$$= \frac{0.131 \text{ mol dm}^{-3} \times \chi}{1000}$$

$$= 0.000131\chi \text{ mol of NaOH}$$

(Where χ is the average titre value obtained from the experiment)

From the stoichiometric equation.

$$1 \text{ mole NaOH} = 1 \text{ mole HCl}$$

$$\therefore 0.000131\chi \text{ moles NaOH} = 0.000131\chi \text{ moles HCl}$$

That is, 25cm^3 of HCl contained 0.000131χ moles HCl

$$\therefore 1000\text{cm}^3 \text{ of HCl will contain } \frac{0.000131 \times 1000 \times \chi \text{ mol dm}^{-3}}{25}$$

$$= 0.00524\chi \text{ mol dm}^{-3}$$

This is the molar concentration of HCl that was in excess and that reacted with the NaOH solution.

From the data provided, the original molar concentration of the HCl acid was $0.303 \text{ mole dm}^{-3}$.

Out of this, 0.00524χ reacted as excess with NaOH

= The molar amount of HCl that must have reacted with the solid Na_2CO_3 sample

$$= 0.303 - 0.00524\chi \text{ mol dm}^{-3} = \gamma \text{ mol/ dm}^3$$

To find the amount in moles, the original molar concentration of HCl was $0.303 \text{ mol dm}^{-3}$

$$\text{i.e. } 1000\text{cm}^3 \text{ will contain } \frac{0.303 \times 25 \text{ moles}}{1000}$$

$$= 0.0076 \text{ moles.}$$

Out of this 0.000131χ moles HCl reacted with the NaOH
 \therefore The mole of HCl that must have reacted with the Na_2CO_3
 $= 0.0076 - 0.000131 \chi$ moles.
 $= Z$ moles of HCl.

From equation 1



That is 2 moles HCl = 1Z mole Na_2CO_3

$$\therefore Z \text{ Mole HCl} = \frac{1}{2} Z \text{ moles } \text{Na}_2\text{CO}_3$$

$$\text{Amount in moles} = \frac{\text{mass}}{\text{Molar mass}} \quad (\text{Remember of a solid particle})$$

$$\text{Molar mass of } \text{Na}_2\text{CO}_3 = (2 \times 23) + 12 + (3 \times 16) = 106 \text{ g mole}^{-1}$$

$$\therefore \text{Amount in moles} = \frac{1}{2} Z \text{ mole} = \frac{\text{mass}}{106 \text{ g mole}^{-1}}$$

$$\text{Mass of } \text{Na}_2\text{CO}_3 \text{ added to solution B} = \frac{1}{2} Z \times 106 \\ = 53Z \text{ g.}$$

I hope you have not been confused by these calculations. This is the reason why I did not use a titre value for the first time so that you can really work yourself into the experiment.

If I may add however, the following values were obtained by me.

$$X = 28.80 \text{ cm}^3$$

$$Z = 0.0038 \text{ } \chi \text{ moles HCl}$$

$$\frac{1}{2} Z = 0.0019 \text{ moles Na}_2\text{CO}_3$$

4.0 Conclusion

In this unit, you have, for the first time used the actual titre values you obtained to solve a problem. You have therefore known the logic behind back titration experiment which essentially demonstrates the indirect method of determining the concentration of a reactant. This situation arises in real life where you have a substance you want to analyze but the substance could not be obtained in a form that you could measure its concentration or that the substance would not dissolve in an aqueous medium thereby making direct titration difficult.

5.0 Answers to SAQ's

1. The resulting solution will be acidic.

UNIT 9: ACID – BASE V DETERMINATION OF AMOUNT OF NaOH AND Na₂CO₃ IN A MIXTURE (DOUBLE INDICATOR METHOD)

1.0 Introduction

In the previous units, we performed experiments where the reactants dictated the choice of indicators. In particular, only one type of indicator was used for each of the cases and only one reactant was being quantitatively analysed. Even in the last unit where an indirect method of analysis was conducted i.e. Back titration, we used only one indicator because the reactants dictated the requirement for the use of one indicator.

However, there are cases where more than one indicator is required for analyzing our sample. We shall look into one of such reactions in this unit as an example of another technique available to you in volumetric analysis. This technique becomes useful when you have a mixture of substances making up a solution.

For example, if we have a solution containing a mixture of NaOH and Na₂CO₃, that we wish to analyse, the use of one indicator to signify the end of the reaction would be misleading because although an end point was indicated, the two substances could not have each reacted with the acid completely. To buttress this point, if HCl was titrated with this solution, the reactants that will occur in the same solution are:

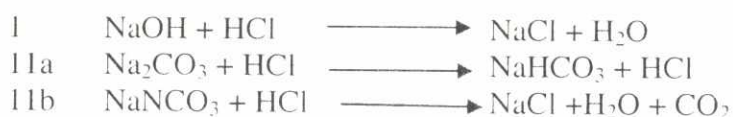

Assuming phenolphthalein is used as indicator, then the pink colour of the indicator is discharged when reactions I and I Ia are complete. This is actually the first step of the titration. At this point, all the NaOH is neutralised together with half of the Na₂CO₃ the other half of Na₂CO₃ will change to NaHCO₃.

If methyl orange is now added and a further quantity of acid is added, the amount of acid required will be that necessary to complete reaction 11b. At this stage, the other half of the carbonate is neutralised. Because one mole of NaHCO_3 is formed from one mole of Na_2CO_3 and hence the quantity of HCl required for reaction 11a and 11b will be the same.

Suppose the volume of the acid needed to reach the end –point as indicated by the phenolphthalein is \underline{a} cm^3 , and the volume of acid reacting with Na_2CO_3 is $2b$ then the volume of acid reacting with NaOH is

$$(a + b) - 2b \text{cm}^3 = (a - b) \text{cm}^3$$

Where:

\underline{b} cm^3 = burette reading at methyl orange end point minus burette reading at phenolphthalein and

\underline{a} cm^3 = burette reading at phenolphthalein end point.

2.0 Objectives

After going through this unit and performing the experiments contained in it, you would be able.

- Estimate individual components in a mixture
- Learn to use two different types of indicator in one titration
- Relate the choice of indicator to type of reaction

3.0 Experiment

Determination of the amount of NaOH and Na_2CO_3 in a given mixture.

3.1 Requirements

'A' is a standard solution of HCl of known molarity. 'B' is a solution of two bases containing unknown quantities of NaOH and Na_2CO_3 .

Additional Materials

- a) One Burette

- b) Phenolphthalein and Methyl orange indicators
- c) Unknown concentration of NaOH and Na₂CO₃ mixture.

3.2 Procedure

First step: Titration of mixture of bases against acid using Phenolphthalein.

1. Rinse the burette twice with solution 'A' containing HCl and fill it with the same acid. Note the initial burette reading.
2. Rinse the pipette with solution 'B' containing a mixture of NaOH and Na₂CO₃ and take 25cm³ portion of this solution into a 250cm³ conical flask and add 2 – 3 drops of Phenolphthalein.
3. Add acid from the burette until pink colour disappears. Note the burette reading of the Phenolphthalein.

Second Step: *Continuation of titration with the same solutions, without adding acid into the burette or base into the conical flask, using methyl orange (1 drop) as indicator.*

4. Add one drop of methyl orange indicator to the colourless solution obtained at the Phenolphthalein end point and continue adding HCl from the burette until one drop of acid gives colour. At this point the remaining NaHCO₃ is neutralised. Note the burette reading again. This is the methyl orange end –point.
5. Now pipette another 25cm³ portion of solution 'B' (base) again into a clean conical flask, fill the burette with HCl solution and start the titration carefully, first using Phenolphthalein. As in step one and then methyl orange as in step two.
6. Repeat the titration until three constant results are obtained.

Problem

From your average titre values, determine

- The concentration in moles per dm^3 of solution NaOH that has reacted
- The concentration in moles per dm^3 of solution Na_2CO_3 that has reacted.
- The amount in grams of the NaOH in the mixture
- The amount in mass of Na_2CO_3 in the mixture
- The percent composition of NaOH in the mixture
- The percent composition of Na_2CO_3 in the mixture (Na = 23, O = 16, C = 12, H = 1).

3.3 Results

Burette Reading, cm^3			Volume of HCl cm^3		
Initial Reading	Phenolphthalein end point (a cm^3)	Methyl orange end point	Vol. of HCl for NaCO_3 (b cm^3)	HCl for the whole of Na_2CO_3 (2 b cm^3)	HCl for NaOH (a - b) cm^3

3.4 Treatment of Results

Calculations:

- For the amount in moles/ dm^3 of NaOH:
 $\text{NaOH} + \text{HCl} \longrightarrow \text{NaCl} + \text{H}_2\text{O}$

First, we find the amount in moles of HCl = $\frac{\text{Molar conc.} \times \text{Volume}}{1000}$

$$= \frac{\text{Molar conc.} \times (a - b) \text{ cm}^3}{1000}$$

$$= \text{C moles}$$

From the stoichiometry, 1 mole HCl = 1 mole NaOH

∴ Amount in moles of C moles HCl = C moles of NaOH

This C mole is contained in the 25cm³ of NaOH used in the titration.

$$\begin{aligned}\therefore 1000\text{cm}^3 \text{ will contain} &= \frac{C \text{ moles} \times 1000}{25} \\ &= 40 C \text{ moles/ dm}^3\end{aligned}$$

b) For the amount in moles / dm³ of Na₂CO₃:



First, we find the amount in moles of HCl

$$\begin{aligned}&= \frac{\text{molar conc.} \times \text{volume}}{1000} \\ &= \frac{\text{molar conc.} \times (2b) \text{ cm}^3}{1000} \\ &= D \text{ moles}\end{aligned}$$

From the stoichiometry, 2 mole HCl = 1 mole NaOH

∴ Amount in moles of D moles HCl = ½ D moles of Na₂CO₃

Thus ½ D mole is contained in the 25cm³ of Na₂CO₃ used in the titration.

$$\begin{aligned}\therefore 1000\text{cm}^3 \text{ will contain} &= \frac{1/2 D \text{ moles} \times 1000}{25} \\ &= 20 D \text{ moles/ dm}^3\end{aligned}$$

c) Amount in g/dm³ of NaOH

$$\begin{aligned}\text{Concentration in g/dm}^3 &= \frac{\text{molar mass} \times \text{molar}}{\text{conc. of NaOH}} \\ &= 40 \times 40C \\ &= 1600C \text{ g/dm}^3\end{aligned}$$

d) Amount in g/dm³ of Na₂CO₃ = $\frac{\text{molar mass} \times \text{molar}}{\text{conc. of Na}_2\text{CO}_3}$

$$\begin{aligned}&= 106 \times 20D \\ &= 200D/\text{gdm}^3\end{aligned}$$

e) Percentage of the NaOH in the mixture.

$$\begin{aligned}\% \text{ of NaOH} &= \frac{\text{Mass of NaOH per dm}^3 \times 100}{\text{the combined mass of the two bases.}}\end{aligned}$$

f) Percentage of the Na₂CO₃ in the mixture

$$\begin{aligned}\% \text{ of Na}_2\text{CO}_3 &= \frac{\text{Mass of Na}_2\text{CO}_3 \text{ per dm}^3 \times 100}{\text{The combined mass of the two bases}}\end{aligned}$$

4.0 Conclusion

The experiment performed in this unit has demonstrated the use of different types of indicators in the same titration for titrimetric analysis. It also allowed for the estimation of any specific substance in a sample mixture.

5.0 Tutor marked Assignment

A 0.620g sample mixture of NaOH, Na₂CO₃ and inert material was dissolved in water and required 30.0cm³ of HCl to reach the Phenolphthalein end point. Methyl Orange was added and 6.50cm³ more of HCl was required to reach the methyl orange end point. If the HCl was 0.24mol/dm³, calculate the % NaOH and Na₂CO₃ in the sample.

Module 2

Quantitative physical inorganic Analysis

1.0 Introduction

In the first module of this introductory Practical Chemistry 1 course, CHM 191, we introduced you to quantitative analytical methods. We exposed you to simple laboratory techniques, laboratory apparatus and operations such as heating, evaporation, cooling and weighing. Some of these techniques and operations you will need at this level of your programme, some you will need at later levels of your programme.

We also exposed you to the concept of mole which we believe will not only enhance your understanding of this practical course but will further improve your general understanding of the general principle of chemistry.

Finally, we treated acid – base titration as an example of quantitative volumetric analysis. In particular, we considered the techniques of standardisation of non-standard aqueous solutions and the determination of amounts of substances in such aqueous solutions.

The present module will further expose you to other application of quantitative volumetric analysis. It will expose you to the Oxidation – Reduction type reactions which are distinct from acid base titrations. But we shall equally use the same mole – concept for the quantitative determination of its constituents.

This module has six units. In the first unit, unit 10, we shall study the theoretical aspect of Redox reactions. What is a Redox reaction? How do we determine which reagent is a reducing or oxidizing agent? And how do we balance the equation of a redox reaction from which the stoichiometric mole ratio could be determined. Next are units 11 and 12 which deal with the experimental procedure applicable to redox reactions.

In these two units we shall treat properties and the oxidizing actions of potassium permanganate, one of the most common and its titrimetric peculiarities and application is treated. Unit 14 gives us a unique

experience of linking the principle of Redox reaction to the relative reactivity of some elements to each other.

In the final unit, unit 15, we shall further expose you to two experiments of fundamental application in quantitative analysis in chemistry which deals with energy relation. The hope is that, the knowledge gained in this unit, will prepare you for two experiment of fundamental application in quantitative analyses in chemistry which deals with energy relation. The knowledge gained in this unit, will prepare you for the understanding of physical chemistry which you will certainly encounter at the next level of chemistry programme.

2.0 Objectives

After studying this module and performing the experiment set in it, you should be able to:-

- 1) Know what type of reactions are classified as Redox reactions.
- 2) Know that the experimental procedures for redox reactions are similar to acid – base reactions.
- 3) Determine the stoichiometric mole ratio from a balanced Redox equation.
- 4) Estimate concentration of reactants from Redox reactions.
- 5) Appreciate energy produced in a chemical reaction.
- 6) Understand the relative activity of metals to each other.

UNIT 10: OXIDATION – REDUCTION REACTIONS

1.0 Introduction

Oxidation – reduction reactions are reactions in which electrons are transferred from one ion or atom or molecule to another of these species in the particular reaction under consideration whether the reaction involves formation of ionic compounds or covalent compounds though it is less obvious in the latter. They are also used in titrimetric analysis like the acid – base reactions we treated in previous units.

Oxidation – reduction titration involves a change in the oxidation state for both substances being determined and the titrant oxidation involves the loss of electrons whereas reduction involves gain of electrons.

These redox reactions unlike the acid – base reactions are very slow and the procedure usually involves the use of catalyst or slight heat.

2.0 Objectives

After studying and going through these units, you should be able to:-

- Understand what Redox reactions are
- Observe that standardization procedures are the same for acid – base reactions
- Appreciate that some titrimetric analyses do not need external indicators
- Estimate concentration of substance from redox reactions
- Write balanced Redox reaction equations.

3.0 Theory

How can I determine the oxidation number or state of an element?

The oxidation number or oxidation state of an element in a compound represents the amount of oxidation (i.e. the number of electrons gained) necessary to convert one atom of the element from the free elemental state which has zero value to that in the compound. Both reduction and oxidation take place at the same time i.e. simultaneously, hence they are sometimes simply termed as REDOX reaction.

To be able to allocate the oxidation numbers of elements, ions, atoms in a compound, you may refer to any standard textbook in chemistry for a full discussion but I shall attempt to discuss the general rules with you.

There are certain guidelines that approximately indicate the oxidation states of elements, atoms and ions in compounds. Three of which are:

- 1) If you remember your periodic table, the ions formed from the elements in all the groups carry either positive or negative charges as their oxidation numbers.

Thus, Hydrogen is in group 1 of the periodic table, so it has +1 oxidation state. Oxygen is in group 6 so it has - 2 oxidation state. Carbon is in group 4 so it has + 4 oxidation state.

- 2) The sum of the oxidation states of all elements in a neutral compound add to zero e.g. $\text{SO}_2 = 0$ whereas in the case of polyatomic ions such as SO_4^{2-} , the sum of the oxidation states of the elements equals the charge on the ion i.e. -2.
- 3) The oxidation state of an element in its natural state is Zero e.g. Cl_2 , Na , P_4 etc.

SAQ 1 What is the oxidation state of C in $\text{H}_2\text{C}_2\text{O}_4$

Answer $\text{H}_2\text{C}_2\text{O}_4 = 0$; $\text{H}_2\text{CO}_3 = 0$
 $2(1) (\text{for H}_2) + \text{C} + 3(-2) = 0$
 $2 + \text{C} - 6 = 0$
 $\text{C} = + 4$

SAQ 2 what is the oxidation state of Cr in $\text{Cr}_2\text{O}_7^{2-}$

Answer Remembering rule 2, $\text{Cr}_2\text{O}_7^{2-} = -2$

Remembering rule 1, $\text{O} = -2$

$$\therefore \text{Cr}_2 + 7(-2) = -2$$

$$\text{Cr}_2 - 14 = -2$$

$$\text{Cr}_2 = 12$$

$$\text{Cr} = +6$$

Remember, when you write the oxidation number, the sign is very important. It is wrong to imply that 6 is the same as +6.

3.1 Oxidizing and reducing agents

In acid – base reactions, the reactants are so identified by their names. That is, there must be an acid and there must be a base. In similar manner, Redox reactions have two different participants. The reducing agent and the oxidizing agent respectively. There cannot be one without the other hence, the term Redox.

How can you differentiate between the two Redox participants? The substance that accepts electrons is called the oxidizing agent and the substance that donates the electrons is the reducing agent. Take this example.



Two things are noticeable from the equation:

- 1) Sodium donates one electron to form sodium ion, therefore it is the reducing agent.
- 2) Na moves from oxidation state of Zero to +1, therefore Na is oxidized.

What I am suggesting to you is that in any equation of this sort, you must be able to identify the reducing or oxidizing agent and the oxidized or reduced specie.

How does one identify and differentiate a reducing agent and an oxidizing agent in a chemical reaction? In a chemical redox reaction, two half equations are usually recognised. One

represents oxidation and the other reduction. The two balanced half equations should add up to the redox equations.

Thus, calculating the oxidation states of all elements in the equation reveal which moved from what value to the other. If an element undergoes an increase in the oxidation number, then it is the reducing agent i.e. the element has been oxidation and if a decrease in oxidizing number is observed, the substance is an oxidizing agent and it has been reduced.

Let us take an example. In the reaction,

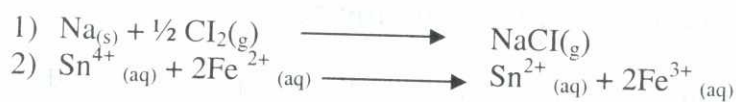

Identify the reducing agent, the oxidizing agent, the oxidized specie and the reduced specie.

Answer:

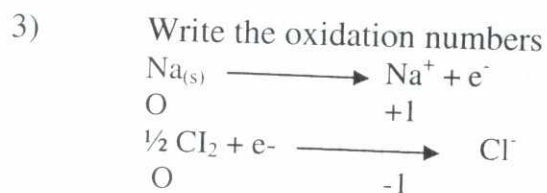
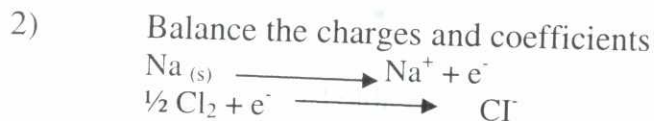
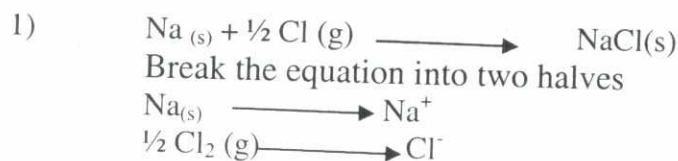

- 4) Identify the species.
 The reducing agent is Na because it donates electron;
 The oxidizing agent is Cl₂ because it accepts one electron
 Na is oxidized because it moves from 0 to + 1 i.e. an increase.

Cl_2 is reduced because it moves from 0 to -1 i.e. a decrease

- 5) In similar manner, we will discover that Sn^{4+} is reduced, Sn^{4+} is the reducing agent and Fe^{2+} is oxidized. Fe^{2+} is the oxidizing agent

The following other rules help in providing assistance in assigning oxidation states to some specific cases.

- 1) Oxygen though is usually -2, its oxidation state is lower in peroxides and super oxides such as Na_2O_2 .
- 2) Hydrogen though usually is +1 but can be found as -1 in its combination with electropositive metals such as NaH .
- 3) In some compounds with constituents atoms having natural negative oxidation states e.g. F_2O . The more electronegative takes the negative value which in this example means oxygen has a + 2 oxidation state.

SAQ3 What is the oxidation state of the underlined element in the following molecule or ion or compound.

- (i) $\underline{\text{I}}\text{O}_4^-$
- (ii) $\underline{\text{N}}\text{H}_4^+$
- (iii) $\text{Na}_2\underline{\text{S}}\text{O}_3$
- (iv) $\underline{\text{K}}\underline{\text{Mn}}\text{O}_4$

Answer

- (i) 1 in $\text{IO}_4^- = +7$
- (ii) N in $\text{NH}_4^+ = +3$
- (iii) S in $\text{Na}_2\text{SO}_3 = +2$
- (iv) Mn in $\text{KMnO}_4 = +7$

There are some well known oxidizing and reducing agents. The common oxidizing agents are KMnO_4 , $\text{K}_2\text{Cr}_2\text{O}_7$, Fe^{3+} compounds, Conc. HNO_3 , Conc. H_2SO_4 , MnO_2 , and Cl_2 . The common reducing agents are Fe^{2+} compounds, Sn^{2+} compounds, KI, pure metals, conc. HCl and SO_2 . It is also known however, that some substances can act as either reducing or oxidizing agent depending on the other substance involved in the reaction.

A good example is H_2O_2 solution which oxidizes $\text{Fe}^{2+}(\text{aq})$ to $\text{Fe}^{3+}(\text{aq})$ but itself is oxidized in another reaction involving aqueous manganate (VII) ion where it is oxidized to oxygen.

3.2 Balancing redox equations

Actually, this is the main problem you will encounter in redox reactions. Whereas in acid base reaction, the coefficients of the reacting species is all the important criteria, in redox reactions apart from the coefficient, the electrons transferred and the medium of the reaction are also very important.

3.2.1 The ion electron method

We talked earlier of writing two half equations in order to distinguish a reducing agent from an oxidizing agent. The same applies here. The two half equations are then added to produce the final balanced equation.

In doing this balancing, you must understand that there are no specific rules but instead we have guidelines which are hereby suggested:

- a) Write the whole net equation without attempting to balance it



- b) Decide which elements undergo changes in oxidation states. Write the partial equations for each of these elements and determine which of the reaction is oxidation and which is reduction.

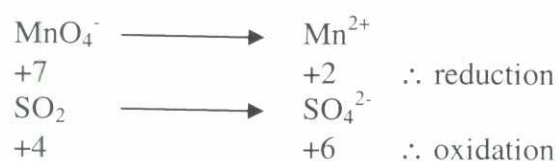

- c) Attempt to balance all the atoms in the two half equations. This you will do by adding coefficients to balance all atoms except those of H and O atoms.

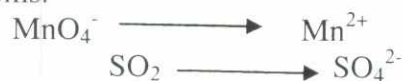

- d) Add appropriate coefficient of H₂O molecules to the side deficient in oxygen. Thereafter you either add H⁺ or OH⁻ to balance the H atoms for acid and alkaline medium respectively.

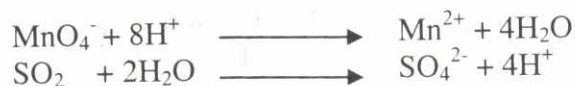

- e) Balance the two half equations electrically by adding electrons to the appropriate side of the equation so that the charges on both sides of the half equations are equal (always add electrons to the side with the higher oxidation)

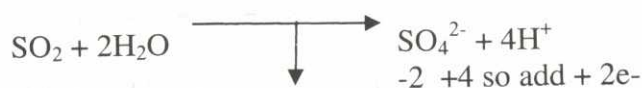

- f) Balance the electrons transferred in both half equations



- g) Add two half equations together and eliminate those electrons, ions or water molecules that appear on both sides of the equation.

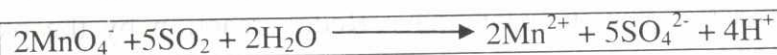
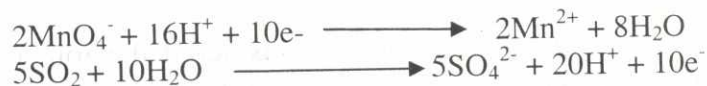

SAQ4

Balance the following redox reaction by the ion – electron method.

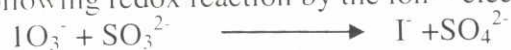

Answer:

Without going through the wordings describing each guiding step, we will attempt thus:

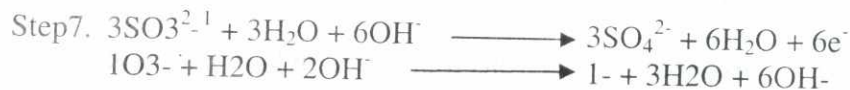
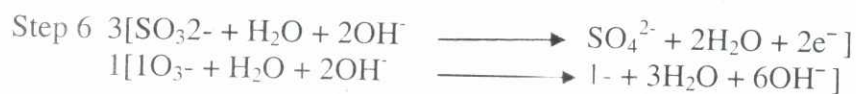
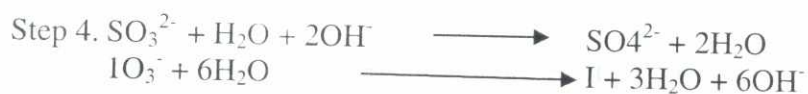
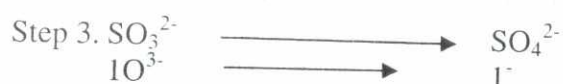
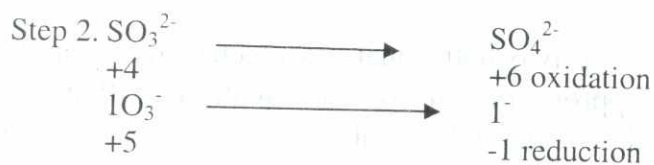

3.2.2 The oxidation state method

As it was indicated when we considered the ion- electron method of balancing a redox reaction, I can only suggest some guidelines which may assist you in balancing a Redox reaction by the oxidation state method.

For example, balance the redox reaction.



1. Determine which elements undergo a change in oxidation state from the reactants to the products.

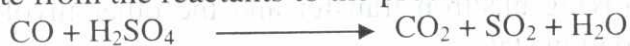

C = 0 to +4

H = +1 to +1

S = +6 to +4

O = -2 to -2

Only C and S underwent changes in oxidation states: C is oxidized and S is reduced.

2. Write the differences in the oxidation states for the elements.
For the increase, C moves from 0 to +4 i.e. a difference of +4
For the decrease, S moves from +6 to +4 i.e. a difference of +2
3. Balance the increase and decrease of oxidation states by placing coefficients in front of the increase or decrease such that the total increase equals the total decrease.
For C: = increase, $+4 \times 1 = +4$
For S = decrease $+2 \times 2 = +4$
4. Multiply the compounds or molecules with the coefficients where the elements concerned are incorporated
 $\text{C} + 2\text{H}_2\text{SO}_4 \longrightarrow \text{CO}_2 + 2\text{SO}_2 + 2\text{H}_2\text{O}$
5. Balance the coefficients of the other reactants.

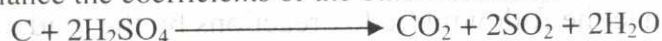

4.0 Conclusion

In this unit, we have found that if we go by the guidelines outlined above, it is possible to balance a chemical equation of a Redox reaction.

5.0 Summary

We can summarize our discussion as follows:

1. There are two related definitions of oxidation. There is one involving electron transfer and the other involving the concept of oxidation state.
2. Oxidation and reduction occur simultaneously.
3. In terms of electron transfer, oxidation can be defined as loss of electrons and reduction as gain of electrons.
4. In terms of oxidation number, oxidation can be defined as increase in the oxidation number and reduction as decrease in oxidation number.

6.0 References and other Resources

C Hill and J. S. Holman, *Chemistry in context*, ELBS and Nelson publishers, low priced edition, 1999.

E.N. Lambert and M. J. Mohammed, *Quantitative Analysis and chemical Calculations*, Heinemann Educational Books, 1983.

7.0 Tutor Marked Assignment

Balance the following redox reactions by the oxidation state method.

1. $\text{MnO}_4^- + \text{Fe}^{2+} + \text{H}^+ \longrightarrow \text{Mn}^{2+} + \text{Fe}^{3+}$
2. $\text{H}_2\text{S} + \text{Cr}_2\text{O}_7^{2-} + \text{H}^+ \longrightarrow \text{S} + \text{Cr}^{3+}$

UNIT 11: REDOX TITRATION II. USE OF POTASSIUM PERMANGANATE AS AN OXIDANT.

1.0 Introduction

Oxidation - reduction (Redox) reactions are the second group of titrimetric analysis we shall consider under volumetric analyses. The others, such as precipitation titration and complexometric titration we said will be encountered at subsequent levels of your programme.

All the basic principles involved in acid - base titrations are also applicable in redox reactions. Redox reactions are however rather slow such that the experiments may involve heating the reactions mixture or using catalysts, to hasten the reaction. The standard reagents used in Redox reactions are oxidizing or reducing agents. As was done for acid - base reactions, the concept of molar concentrations is also applicable to Redox reactions (you may therefore refresh your self with the mole concept discussed in module 1 of this course).

The amount of the oxidizing agent and that of the reducing agent titrated are related exactly as in the ratio shown in the stoichiometry in the balanced equation of the reaction at the end point. This means that

The amount in moles dm^{-3} of oxidizing agent = amount in moles dm^{-3} of oxidizing agent

In our treatment of Redox titrations, we shall concern ourselves with only two different oxidizing agents. These are potassium permanganate and the other is iodine solution. But first let us deal with potassium permanganate, solution.

2.0 Objectives

After studying and performing the experiments in this unit, you should be able to:-

- Explain the basic concepts underlying the use of potassium permanganate as an oxidizing agent
- Describe the characteristics feature of potassium permanganate solution

- Expose you to some titrimetric analysis that may not require use of an external indicator.
- Explain the basic concepts involved in the use of iodine as an oxidizing agent.
- Describe the characteristic features of iodine solution.
- Perform some redox titrimetric analysis requiring the use of an external indicator.
- Estimate the concentrations of reagents participating in a Redox reaction.

3.0 Experiment

Standardisation of a solution of potassium permanganate by a standard reductant acid.

3.1 Introduction

Potassium Permanganate (KMnO_4)

The most widely used oxidizing agent in redox titrations is potassium permanganate. It is found useful in both acidic and basic media. It may also be used in neutral solution. It however acts best in acid medium. Potassium permanganate in both solid and aqueous form is purple in colour so that addition of an organic indicator to detect the end point is meaningless because the change in colour of the organic dye indicator will not be distinctly observed as it will be masked by the colour of the potassium permanganate.

Thus, KMnO_4 acts as a self indicator. The first drop of excess KMnO_4 produces a distinct colour change.

Finally, because of its intense colouration, it is often very difficult to read the meniscus of the KMnO_4 solution in a burette. The practice therefore is to read the surface of the solution.

Potassium permanganate cannot be used as a primary standard because it is difficult to obtain pure. Even in solutions, it is decomposed by light

and traces of organic matter. Thus, the potassium permanganate solution intended for redox titrations must be standardised prior to use.

From the features of potassium permanganate described therefore, it would be obvious to us that before we can use potassium permanganate as an analytical reagent, its actual concentration must be determined since it cannot be obtained pure.

In practice, it is standardised by use of a number of standard reagents. Some of these are ammonium iron (II) sulphate, sodium ethanedioate and ethane dioic acid. In this particular laboratory exercise, we shall make use of a standard solution of ethanedioic acid (oxalic acid) a hydrated dibasic acid, that can be obtained in high purity. Oxalic acid is a good reducing agent even though it is an acid.

Since the best performance of KMnO_4 is in the acid medium, if the contents of the conical flask turns brown, it means insufficient acid catalyst was added, addition of more acid would revert the solution to colorless. Not all acids act as catalysts for permanganate reaction though. The only acid suitable for use is dilute sulphuric acid. Hydrochloric acid will be oxidized to chlorine.

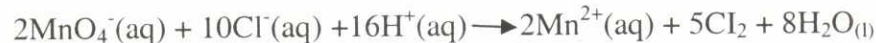

While nitric acid would compete with the permanganate ion for the reducing agent because itself is a strong oxidizing agent like the KMnO_4 .

3.2 Objectives

At the end of this practical laboratory class, you should be able to:-

- Standardise potassium permanganate solution.
- Perform titration without the need for an external indicators.
- Carry out titration reactions at elevated temperatures.
- Estimate amount of reagents from Redox reactions.

3.3 Requirements

Chemical	Apparatus Quantity	
KMnO ₄ solution	Burette (50cm ³)	1No
2M H ₂ SO ₄	Pipette (25cm ³)	1No
Oxalic acid solution	Bunsen burner	1No
Distilled water	Gauze	1No
	Tripod stand	1No
	Clamp	1No
	Retort stand	1No
	Measuring a cylinder	1No
	Conical flask (25cm ³)	3No

3.4 Procedure

1. Rinse the burette (50.0cm³) twice with a few cm³ of KMnO₄ solution. Fill the burette with the KMnO₄ solution above the Zero mark and drain to this mark, making sure the burette tip is full and the air is expelled within the body of the KmnO₄ solution.
2. Pipette out 25.0cm³ of the Oxalic acid solution to a 250cm³ conical flask, add about 15cm³ of 2M H₂SO₄ and heat to between 60 – 80⁰c.
3. Titrate the hot mixture with KMnO₄ solution until it retains a permanent faint pink colour.
4. Repeat the titration using fresh sample each time until at least two titrations are within 0.5cm³ accuracy.
5. Record your titre values using the format in previous experiments and find the average titre value.
6. From your results determine.
 - a. The number of moles of oxalic acid used in the titration.
 - b. The number of moles of permanganate used in the titration.

- c. The concentration in mol dm^{-3} of permanganate i.e. molarity.
- d. The concentration in g dm^{-3}
(Mn = 55, K = 39.0, C=12, H = 1, N =14).

3.5 Results

Burette Reading	1 st titration	2 nd titration	3 rd titration
Final reading			
Initial Readings			
Volume of KMnO_4 used			

3.6 Treatments of Results

You should be familiar with the procedure in treating results that you have obtained from performing a volumetric (titrimetric) analysis. The procedure for Redox reactions is essentially similar to acid / base titration. The main problem is the perceived difficulty in balancing the redox equation. The following steps can be used as guidelines:

Step 1: The equation of the reaction

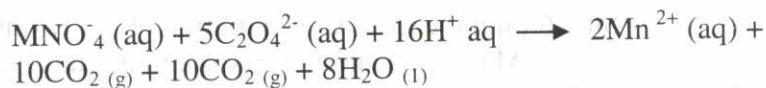

From the equation, the mole ratio between the reactants is,
5moles $\text{C}_2\text{O}_4^{2-} (\text{aq})$ is = 2mol $\text{MnO}_4^- (\text{aq})$

Step 2. We shall assume the followings:

1. the potassium permanganate solution was prepared by dissolving between 1.4 and 1.6g of the solid in 1dm^3 of solution
2. The standardised oxalic acid solution was prepared by dissolving 0.84g of solid in 250cm^3 of solution.
3. The average titre value obtained for KMnO_4 is $V\text{cm}^3$.

Step 3. The concentration of $\text{Na}_2\text{C}_2\text{O}_4$ in $\text{mol dm}^{-3} = \frac{4 \times 0.84}{90}$
 $= 0.037 \text{ mol dm}^{-3}$

No of moles used in the titration = $\frac{\text{Molarity} \times \text{volume}}{1000}$

$= 0.0009 \text{ moles of } \text{Na}_2\text{C}_2\text{O}_4$

Step 4. Find the number of moles of KMnO_4

From the equation of reaction

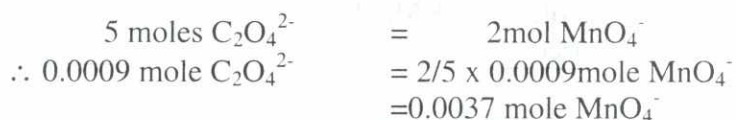

Step 5. Find the amount in moles dm^{-3} of the KMnO_4 solution

$$\begin{aligned} \text{Moles } \text{dm}^{-3} &= \frac{\text{No of mole} \times 100}{V_m} \\ \text{Moles } \text{dm}^{-3} &= \frac{0.000376 \times 1000}{V_m} \\ &= \frac{0.37}{V_m} = X \text{ moles } \text{dm}^{-3} \end{aligned}$$

Step 6. Find the mass Concentration of the KMnO_4

Mass concentration = Con. in $\text{mol dm}^{-3} \times \text{molar Mass } \text{KMnO}_4$

$$\begin{aligned} &= X \text{ mol dm}^{-3} \times 158 \text{ g mol}^{-1} \\ &= 158X \text{ g dm}^{-3} \end{aligned}$$

4.0 Conclusion

From the experiment just performed, we have found out that the actual concentration of the potassium permanganate solution can only be found after it was standardised.

5.0 Summary

1. Potassium permanganate is an oxidizing agent.
2. In performing the Oxidizing action, it must be standardised by a primary standard such as oxalic acid.

3. Potassium permanganate is a self indicating reagent. It does not require the addition of an external indicator because of its different characteristic colour changes in either the acid or basic medium.

UNIT 12: REDOX TITRATION 111 USE OF POTASSIUM PERMANGANATE AS AN OXIDANT

1.0 Introduction

If you recall in unit 7, one of the acid – base titrations we performed, was the determination of the percentage purity of a substance. In the demonstration of a similar applicability to redox reactions, we shall in this practical laboratory class attempt to determine the percentage purity of a reductant, $\text{FeSO}_4 \cdot 7\text{H}_2\text{O}$. This we will do by titrating against the standardised solution of potassium permanganate from unit 11.

2.0 Objectives

At the end of this practical class, you should be able to:

- Estimate the percentage purity of a substance using potassium permanganate as an oxidant.
- Use a standardised solution of potassium permanganate to estimate the concentration of a non – standard solution.

3.0 Experiment

Determination of the concentrations of a solution of $\text{FeSO}_4 \cdot 7\text{H}_2\text{O}$ using a standard solution of potassium permanganate.

3.1 Requirements

Chemical	Apparatus	Quantity
KMnO_4 solution	Burette (50cm^3)	1No
2M H_2SO_4	Pipette (25cm^3)	1No
$\text{FeSO}_4 \cdot 7\text{H}_2\text{O}$	Bunsen burner	1No
Distilled water	Wire Gauze	1No
	Tripod stand	1No
	Clamp	1No
	Conical flask (25cm^3)	3No

3.2 Procedure

1. Rinse the burette (50.0cm^3) twice with a few cm^3 of KMnO_4 solution. Fill the burette with the KMnO_4 solution above the Zero mark and drain to this mark, making sure the burette tip is full and any air is expelled within the body of the KMnO_4 solution.
2. Pipette out 25.0cm^3 of the solution of $\text{FeSO}_4 \cdot 7\text{H}_2\text{O}$ into a 250cm^3 conical flask and add to it 20cm^3 of 2mol dm^{-3} sulphuric acid. Heat to between 60 and 80°C .
3. Titrate the hot mixture with KMnO_4 from the burette until the solution in the conical flask attains a permanent faint pink colour.
4. Repeat the titration using fresh samples each time until at least two titrations are within 0.2cm^3 accuracy.
5. Record your titre values using the format in previous experiments and find the average titre value.
6. From your results, determine
 - a. The number of moles of potassium permanganate used in the solution.
 - b. The number of moles of the iron compound.
 - c. The concentration in mol dm^{-3} of the iron compound
 - d. The percentage purity of the crystals.

(Mn = 55, K = 39, O = 16, C = 12, H = 1, N = 14, S = 32, Fe = 56)

3.3 Results

Burette Reading	1 st titration	2 nd titration	3 rd titration
Final reading			
Initial Readings			
Volume of KMnO ₄ used			

Average volume used.

3.4 Treatment of Results

Step 1: The equation of the reaction

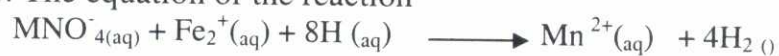

Step 2. We shall assume the followings:

1. The permanganate solution used is the standardised solution from the pervious experiment.
2. The amount in mol dm^{-3} of the KMnO₄ is 0.002 mol dm^{-3} .
3. The average titre value for KMnO₄ is $W \text{ cm}^3$.
4. The FeSO₄ · 7H₂O solution was prepared by dissolving about 7.6g of the crystals in 250 cm^3 of solution.

Step 3. The number of moles $\text{MnO}_4^- = \frac{\text{Molarity} \times (\text{volume}) \cdot W}{1000}$

$$= \frac{W \times 0.02}{1000}$$

$$= M \text{ moles}$$

Step 4. Find the number of moles of the iron II crystals from the stoichimetric equation of the reaction

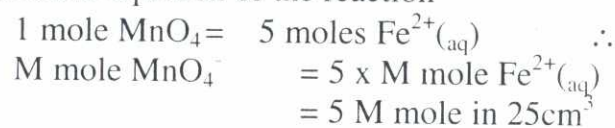

Step 5. The number in moles dm^{-3} of the Fe^{2+}

$$\begin{aligned} &= \frac{\text{No of mole} \times 1000}{\text{Volume}} \\ &= \frac{5\text{M} \times 1000}{25} \\ &= 200\text{M molesdm}^{-3} \end{aligned}$$

Step 6. The mass Concentration of the $\text{FeSO}_4 \cdot 7\text{H}_2\text{O}$

$$\begin{aligned} \text{Mass concentration} &= \text{moldm}^{-3} \times \text{molar Mass} \\ &= 20\text{M} \times 278\text{gdm}^{-3} \\ &= 5560\text{Mgdm}^{-3} \\ &= \text{Ngdm}^{-3} \end{aligned}$$

Step 7. Estimate the percentage purity of the iron salt

$$\begin{aligned} \text{Percent purity} &= \frac{\text{mass determined during experiment}}{\text{Actual mass of iron in } 100\text{cm}^3} \\ &= \frac{\text{Ngdm}^{-3} \times 100}{4 \times 7.6} \\ &= \text{q}\%. \end{aligned}$$

4.0 Conclusion

From the experiment you have learnt that the standardised solution of potassium permanganate can be used to determine the concentration of a non – standard solution. We also discovered that we can use the techniques to determine the purity of a substance as we similarly did for acid – base titration analysis.

5.0 Summary

In this unit,

1. Potassium permanganate, a very useful oxidant in redox reactions can be used to estimate the percent purity of a substance and water of crystallisation of a substance as was done for the acid base reactions.

UNIT 13: REDOX TITRATION IV; USE OF POTASSIUM IODATE AS AN OXIDANT.

1.0 Introduction

In unit 11 our discussion was on using potassium permanganate as an oxidizing agent. But we had mentioned that we will look at the actions of another oxidizing agent. This is iodine solution. The reason why we are looking at redox reactions of these two, is that they present different features of Redox reactions.

2.0 Objectives

This unit sets to demonstrate the use of iodine as an oxidizing agent in redox titrations.

SAQ1

Can you recall the properties associated with the use of potassium permanganate as an oxidizing titrant in redox reaction?

Answer

1. Potassium permanganate cannot be used as primary standard
2. Because it is characteristically coloured in both acid and basic media, it does not require the use of an external indicator. Thus, it acts as a self indicator.
3. Because it is coloured, the experimenter will have to read the upper meniscus of the burette for accurate reading.
4. Although, it works in both acidic and basic media, it acts best in the acid medium. Not all acids are equally suitable, sulphuric acid is best suitable.

3.0 Theory of Oxidizing Action of Iodine

Volumetric analyses involving iodine are usually referred to as Iodimetry. Two distinct classes of methods of analyses are possible here. The direct method and the indirect method.

In the **direct method**, standard solutions of iodine are used to estimate directly the concentrations of some oxidizable species such as SO_3^- , S_2O_3^- , H_2S , S^- and Sn^{2+} , the half equation representing this oxidizing action can be represented as:



In this way, iodine is rather selective to only the powerful reducing agents. Thus, it can be used to determine the concentrations of strong reducing agents. However, there is a problem associated with the use of iodine as a result of its being sparingly soluble in the aqueous medium in which the Redox reactions take place. To overcome this, it is normally dissolved in aqueous potassium iodide. In the KI solution, it forms the tri-iodine ion. It is this ion that actually acts as the oxidizing agent on behalf of iodine. The equation for this is represented below:

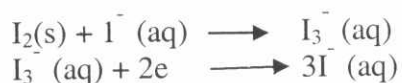

In the **indirect method**, the excess iodine ion that is deliberately produced in a reaction involving say potassium iodide in an acid medium is made to react with another different oxidizing agent. In this reaction, the quantity of iodine liberated is chemically equivalent to the quantity of oxidizing agent used. The reaction can be presented by most common oxidizing agents such as MnO_4^- , Bromine, Chromate, dichromate, manganate and iodate would liberate this iodine, for example using bromine as an example



This liberated I_2 is now quantitatively determined by titration with standard sodium thiosulphate solution acting as reducing agent according to the equation below.



The equivalent mole ratios for the three reactions will be

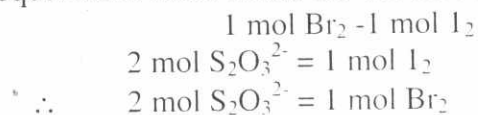

If we use iodate (v) as the oxidizing agent, the relevant equations will be

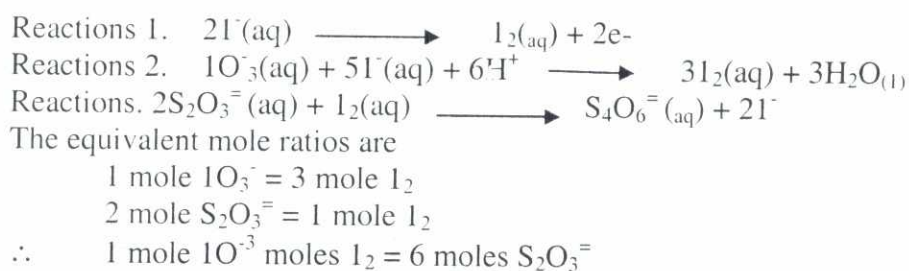

Of all the oxidizable species available for use, iodine titrations are usually used with the thiosulphate.

SAQ 2

Using copper (II) ions as the oxidizing agent to liberate iodine from iodide ions, quantitatively determining the liberated iodine by titration with sodium thiosulphate solution, deduce the equivalent mole ratios.

Answers

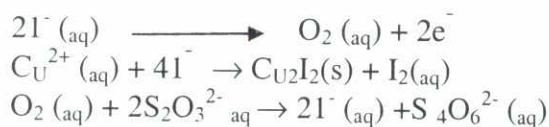

The equivalent mole ratios are

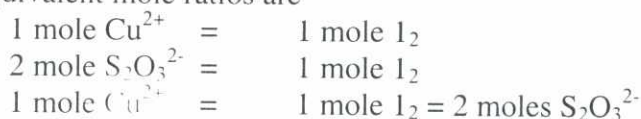

1.2 Indicators for iodimetry/ Iodometry titrations

When we discussed using permanganate ion as the oxidizing agent, we arrived at the observation that no external indicators are required during the titrations. Can you remember the reason we gave for not requiring an external indicator when the permanganate is the titrant?

In the case of iodine the situation is different, there could be 2 general cases.

1. When the solutions being reacted with iodine are colorless. It may also require no external indicator because the colour changes accompanying the varying change in oxidation states of iodine and

excess aqueous iodide and the liberated iodine is titrated with the thiosulphate solution to be standardised.

3.2 Objectives

At the end of this practical class, the student should

- Know how to standardise a solution of sodium thiosulphate
- Have been exposed to iodine titrations involving the use of starch as indicators
- Learn how to derive equivalent mole ratios from various reductants and oxidants
- Learn to do calculations from redox reactions

3.3 Requirements

Chemical	Apparatus Quantity	
Potassium iodide solution	Volumetric flask 1dm ³	2No 2No
Sodium thiosulphate solution	Conical flask 250cm ³	3No 1No
Potassium iodate solution	Burette (50cm ³)	1No
Starch indicator	Pipette 25cm ²	1No
1M hydrochloric acid	Clamp Retort stand	1No

3.2 Procedure

1. First rinse the burette twice with a few cm³ of the thiosulphate solution and pour above the Zero mark than drain to this mark, making sure the burette tip is full and the air is expelled within the body of thiosulphate solution.
2. Pipette out 25.0cm³ of the potassium iodate (v) solution into the conical flask. Add about 20.0cm³ of the hydrochloric acid and then

its ion can be used to indicate the end point. The colour changes are as follows.

Redbrown (initially) \longrightarrow light yellow (near the end point)
 \longrightarrow Colourless (at the end point).

2. When the solutions are not colourless, an indicator must be used. The most commonly used external indicator for iodine titration is starch solution. This forms a blue black complex with the tri-iodide ion during the titration that is rapidly discharged at the end point. Thus using starch as indicator, the colour variations of the solution depend on complex formation of the starch with iodide ion formed in the last stage of the titration.

For this reason and in order to avoid complications in the end point detection, the starch indicator is added at the light yellow colouration of the solution which is near the end point. At this point, the solution becomes blue black and finally changes to colourless at the end point. The colour changes can be represented thus:

Redbrown (initially) \longrightarrow light yellow (near end point)
 \longrightarrow blue black (at adding of starch) \longrightarrow Colourless (at the end point).

2.0 Objectives

This unit sets to demonstrate the use of iodine as an oxidizing agent useful in Redox titrations.

3.0 Experiment

Standardisation of an aqueous solution of sodium thiosulphate by a standard solution of potassium iodate (V)

3.1. Introduction

In this experiment our specific attention is focused on iodine as an oxidizing agent. In this experiment, an approximate concentration of sodium thiosulphate, $\text{Na}_2\text{S}_2\text{O}_3 \cdot 5\text{H}_2\text{O}$ is standardised against a primary standard. In practice, a fixed quantity of the iodate (v) is added to

add about 10.0cm^3 of the potassium iodide. Shake and titrate immediately the liberated iodine with the thiosulphate solution.

3. Monitor the change in the colour of the solution in the conical flask from redbrown to pale yellow. Then at this point add 3- 5 drops of the starch indicator. You will notice the solution changing to blue black. Continue the addition of the thiosulphate drop by drop until the blue colour disappears. This is the end point. Note that titre value.
4. Repeat the titration using fresh samples each time until at least two titrations are within 0.2cm^3 accuracy.
5. Record your titre values using the format in previous experiments.
6. Find the average titre value.

From your results, determine

1. The number of moles of the iodate
2. The amount in mol dm^{-3} of the thiosulphate ion
3. The mass concentration in g dm^{-3}

(K = 39, I = 127, O = 16, Na = 23, S = 32, H = 1)

3.5 Results

Burette Reading cm^3	1 st titration	2 nd titration	3 rd titration
Final reading			
Initial Readings			
Volume of $\text{S}_2\text{O}_3^{2-}$ used			

$$\text{Average volume use} = \frac{. + . + .}{3}$$

3.6 Treatment of results

Step 1. The equations of the reaction

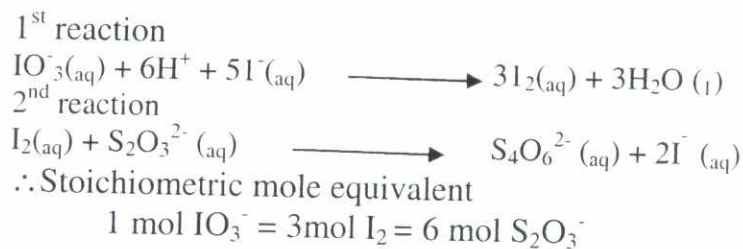

Step 2: We shall assume the following:

1. The sodium thiosulphate solution was prepared by dissolving 19.5g of the crystals in 1dm³ of solution
2. The average titre value of is Vcm³
3. The potassium iodate (v) solution was prepared by dissolving 1.5g of crystals in 500cm³ of solution.

Step3. Number of moles of KIO₃ = $\frac{1.5}{214} = 0.0070$ moles

That is, 0.0070 moles is contained in 500cm³

$$\begin{aligned}
 \therefore \text{In } 1000 \text{ cm}^3, \text{ it will contain} &= \frac{\text{no of moldm}^{-3} \times 1000}{\text{Volume}} \\
 &= \frac{0.007 \times 1000}{500} \\
 &= 0.014 \text{ moldm}^{-3}
 \end{aligned}$$

Step 4. From the equations the stoichiometric mole ratios



$$\therefore \text{No of moles of IO}_3^- \text{ in } 25\text{cm}^3 = \frac{\text{moldm}^{-3} \times 25}{1000}$$

$$= \frac{0.0014 \times 25}{1000}$$

$$= 0.00035 \text{ moles of IO}_3^-$$

$$\begin{aligned} \therefore \text{No of moles of } S_2O_3^{2-} \text{ in } V\text{cm}^3 &= 6 \times 0.00035 \\ &= 0.002 \text{ moles} \end{aligned}$$

$$\begin{aligned} \therefore \text{Molar concentration} &= \frac{\text{moles} \times 1000}{V\text{cm}^3} \text{ moldm}^{-3} \\ &= \frac{0.002 \times 1000}{V\text{cm}^3} \\ &= \frac{2 \text{ moldm}^{-3}}{V} \\ &= z \text{ moldm}^{-3} \end{aligned}$$

$$\begin{aligned} \text{The concentration in } \text{gdm}^{-3} \text{ of the } Na_2S_2O_3 \cdot 5H_2O & \\ &= \text{molar mass} \times \text{moldm}^{-3} \\ &= 248 \times z \\ &= 248z \text{ gdm}^{-3} \end{aligned}$$

4.0 Conclusion

The results obtained from the experiment has demonstrated that:

- 1) Iodine solution can be used as an oxidizing agent in titrimetric analysis.
- 2) The actual concentration of the thiosulphate crystals was 19.5g.

5.0 Summary

1. Iodine is one of the titrant commonly used in Redox titration after potassium permanganate.
2. In titrations involving iodine, the thiosulphate is usually the reductant.
3. Iodine is used in two ways. The direct method uses iodine directly to estimate the concentrations of the oxidizable agent. In the indirect method, an oxidizing agent is first reacted with an iodide which liberates iodine which is then titrated with thiosulphate.
4. When iodine requires an external indicator, it is usually starch that is used.

UNIT 14: REDOX (REACTIVITY) SERIES IN METALS

1.0 Introduction

In the previous units, the quantitative determination of substances in a reaction occurring in aqueous medium were performed through volumetric analytical techniques. However, there are other techniques that can be used to determine other specific properties of a reaction. Such other techniques include gravimetric and instrumental analysis.

In gravimetric analysis, the constituent to be determined is isolated either as an element or as a compound of definite composition. This element or compound is weighed and from its weight, its known chemical composition, the amount of the desired component is determined. In some cases this element or compound is separated by precipitation with a chemical reagent. In a few other cases, it is deposited on an electrode by electrolytic means.

2.0 Objectives

After going through this unit, you will be able to:

- Determine the relative reactivity of metals to each other.
- Determine the relative atomic weight of a metal.

3.0 Experiment 1.

Determination of the relative reactivity of Metals

3.1 Introduction

When metals are placed a solution of another metal ion, two things are expected to occur. Either a reaction is observed which is indicated by precipitation of the metal or no reaction is observed. What determines whether a displacement reaction will occur or not is dependent on the relative oxidation or reduction capability of the metals and their salts in question. In chemistry, this relative reactivity is revealed in the redox

potentials of the metals which have been compiled over time. A list of such potentials is given in the Experiment 2 of this unit.

3.2 Objectives

After going through this experiment, you will be able to:

- Arrange a group of metals in order of decreasing or increasing reactivity amongst the group.
- Determine quantitatively, the relative reactivity of metals to each other.

3.3 Requirements

Apparatus

Test-tube Rack

Test-tubes

Three (3) copper strips, 3 zinc strips, 3 iron strips

Reagents

0.1 mole/dm³ each of CuSO₄, FeSO₄ and Zn (NO₃)₂

3.4 Procedure

1. Arrange three empty test tubes on a test tube rack.
2. Put 5cm³ of each of the solutions into a test tube.
3. Put a strip of zinc metal into each of the three test tubes. Shake. Observe for 30 minutes.
4. Record your observations in the three test tubes. Which showed no visible reaction? Which showed coatings on the strips?
5. Repeat the procedure for each of the metals using fresh solutions each time and record your observations.

3.5 Results

Prepare a table using the format below and tick *for no visible reaction and ** for visible reaction

	CuSO ₄	FeSO ₄	Zn(NO ₃) ₂
Zinc metal			
Copper metal			
Iron metal			

3.6 Treatment of Result

1. If a metal strip is coated with another metal when placed in a solution of that salt, it indicates that the metal strip is more reactive than the metals whose solution it was put.
2. There should be no visible reaction when a metal is placed in solution of its own ions.
3. Arrange the metals in decreasing order of reactivity.

SAQ

In a group of metal, calcium, tin, copper and aluminum, each of which was put in a solution of the ions of the respective metal, the following observations were recorded.

1. The tin metals reacts with the copper (II) ions in solutions but not with the aluminum ions.
2. The calcium metals reacts with the aluminum ions.
3. No visible reaction was noted from the metal when put in a solution of its own salt.

Arrange the metals in order of decreasing reactivity.

Answer

From the above information, tin is more reactive than copper, but less reactive than aluminum, while calcium is more reactive than aluminum. The order is Ca > Al > Sn > Cu.

4.0 Experiment

Determination of the relative atomic weight of copper by displacement of copper element with silver metal.

4.1 Introduction

In the previous section of this unit, we discussed the relative reactivity of metals to each other. Qualitatively, this was done by noting the reaction of one metal in the solution of another metal. This description was purely a qualitative description. In actual fact, the drive for the displacement of the metals in a solution of another metals is another example of Redox reactions.

If you remember, we had discussed what redox reactions are. But we may need to remind ourselves. But perhaps the incentive for this experiment is to demonstrate another useful application to which redox reactions can be put in chemistry. That is, it can be used to determine the relative atomic mass of an element.

A substance that loses an electron is said to be oxidized while one that gains an electron is said to be reduced. Elements may be arranged in order of their ease of oxidation. A list of increasing value of oxidation potentials various elements will be seen in standard chemistry textbooks given as electrochemical series.

Oxidation potentials of some elements

Element		Oxidation potential
Na	→	$\text{Na}^+ + e$ +2.71
Mg	→	$\text{Mg}^{2+} + 2e$ +2.37
Al	→	$\text{Al}^{3+} + 3e$ +1.66
Zn	→	$\text{Zn}^{2+} + 2e$ +0.76
Fe	→	$\text{Fe}^{2+} + 2e$ +0.44
H_2	→	$2\text{H}^+ + 2e$ 0
Cu	→	$\text{Cu}^{2+} + 2e$ -0.34
2I^-	→	$\text{I}_2 + 2e$ -0.54
Ag	→	$\text{Ag}^+ + e$ -0.80
2Br^-	→	$\text{Br}_2 + 2e$ -1.09
2Cl^-	→	$\text{Cl}_2 + 2e$ -1.36

The more positive the potential, the easier will be the oxidation. Thus sodium metal is easily oxidized to sodium ions while chloride ions are not easily oxidized to chlorine atoms.

When considering a pair of oxidation potentials, the metal with the more positive (less negative) oxidation potentials will be spontaneously oxidized while the metal having the less positive (more negative) oxidation potential will be reduced. For example,

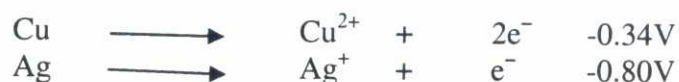

Copper having the more positive oxidation potential is oxidized while silver with the less positive oxidation potential is reduced.

4.1 Objectives

At the end of the laboratory class, you will be able to:

- Study the oxidation potentials of certain metals.
- Investigate the replacement of metallic copper by silver.
- Confirm atomic weight of copper.

4.3 Requirements

One piece of copper wire about 20cm long, 50cm³ of 0.1 moldm⁻³ AgNO₃

Pieces of sand paper	100cm ³ capacity beakers
16 x 150mm test tube	filter paper (gcm)
Light painters brush	source of flame
Watch glass	oven

4.4 Procedure

1. Measure out about 50cm³ of 0.1 moldm⁻³ AgNO₃ in a clean 100cm³ beaker.

2. Clean the copper wire between sand paper, wash and dry it.
3. Wrap it around a 16 x 150mm test tube to form a coil, leaving about 4cm handle.
4. Weigh the coil and place it into the AgNO_3 solution, leaving the handle clear of the solution (figure 1).
5. Leave it for 30 – 40 minutes, stirring occasionally by the handle to shake off the deposited silver.
6. While that is going on, take a clean dry filter paper (9cm), fold it in the form of a cone for filtering, place it on a clean dry watch glass, and weigh them together.
7. After about 40 minutes, wash all the silver off the copper wire into the beaker with distilled water. Scrub the coil gently with your brush rinsing it into the beaker, and set the coil aside to dry on a clean surface.
8. Pass briefly over a flame to dry completely, and weigh.
9. Filter the silver solution through the previously weighed filter paper. While this is going on, boil about 50cm^3 of distilled water.
10. Wash the deposited silver three times with portions of boiled water.
11. When the wash water has completely drained, **CAREFULLY** remove the filter paper with silver, place it upside down on the weighed watch glass (label it!) and place it in the oven (110°C) for 30 minutes.
12. While the silver is drying, clean up the work bench and begin filling out your report sheet.
13. After drying, allow the silver, watch glass and paper to cool to room temperature before weighing again.

14. Repeat for 5 minutes, cool and weigh again to be sure it is dry.
15. Return copper wire, deposited silver and silver wastes to the demonstrator.

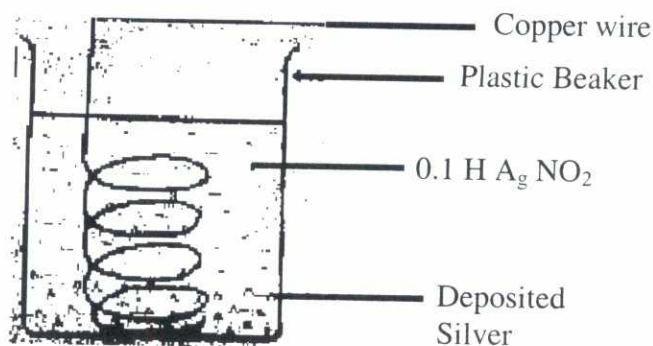

Figure 1. Deposition of silver

4.5 Results

Initial weight of copper = C_1
 Final weight of copper = C_2
 Mass of copper deposited = $C_2 - C_1 = Cg$
 Weight of silver deposited = Sg
 (Relative atomic mass of silver = 107.78)

4.6 Treatments of Result

The equation of the reaction can be written as;

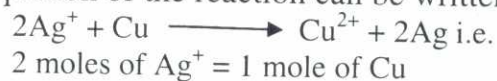

In this experiment, a weighed piece of copper wire had been placed in solution of silver ions. The copper was oxidized to copper ions while silver ions were reduced to metallic silver. From the accepted atomic mass of silver, the weight of silver deposited and the weight loss of the copper, the atomic mass of copper can be confirmed.

5.0 Conclusion

The experiments have demonstrated the relative reactivity of some metals to each other. Specifically, the experiments have shown that in a composition of relative reactivities in a group of metals containing calcium, copper, aluminum and tin, the reactivity is, in order of decreasing reactivity: $\text{Ca} > \text{Al} > \text{Sn} > \text{Cu}$ and in a group containing copper, iron and Zinc, the reactivity in decreasing order is Zn, Fe and Cu.

6.0 Summary

1. When considering a pair of oxidation potentials, the metal with the more positive (less negative) oxidation potential will be spontaneously oxidized while the metal having the less positive (more negative) oxidation potential, will be reduced.
2. A substance that loses an electron is said to be **oxidized** while one that gains an electron is said to be **reduced**.
3. Redox reactions are reactions which involve the simultaneous processes of Reduction and Oxidation.

UNIT 15: ENERGY EFFECTS IN CHEMICAL REACTIONS

1.0 Introduction

Chemical and physical processes are usually accompanied by heat gain and or heat loss. The study of thermal changes in such processes is known as Thermochemistry or Thermodynamics. A process that is accompanied by a heat gain is said to be ENDOTHERMIC while one that is accompanied by heat loss is EXOTHERMIC. Examples of Endothermic reactions are addition of ammonium chloride, NH_4Cl to water and addition of sodium ethanoate, CH_3COONa , to water. Example of exothermic reactions are addition of concentrated acids to water, neutralisation reactions displacement reactions and addition of NaOH or KOH pellets to water.

2.0 Objectives

After going through this laboratory class, the student will be able to:

- Assemble and use a simple calorimeter.
- Determine the heat capacity of metallic copper.
- Determine the heat of neutralisation for a strong acid – strong base reaction.

3.0 Experiment 1. Determination of Specific Heat Capacity for Copper

3.1 Introduction

Since different substances conduct heat to varying degrees, specific heat capacity can be defined for each substance. The specific heat capacity is a measure of the amount of heat required to raise the temperature of one mole of the substance through 1°C .

3.2 Requirements

One calorimeter frame
Two $0 - 110^\circ\text{C}$ thermometers
One stirrer

One piece of copper metal
 $100\text{cm}^3 = 1\text{M NaOH}$ (record exact concentration)
 $100\text{cm}^3 = 1\text{M HCl}$
Distilled water
Crucible tongs

3.3 Procedure

1. Assemble a calorimeter as shown in figure 1 or 2.
2. Transfer 80cm^3 of distilled water (use a measuring cylinder) to the calorimeter, close the top and insert the thermometer and stirrer.
3. Stir until the temperature is constant, then record that temperature as T_i^w (initial temperature of water) in your note book.
4. Prepare a boiling water bath with about 4cm^3 water in a water bath. While it is heating, weigh accurately the copper metal.
5. Place the copper metal in the boiling water and boil for 10 minutes. Record the temperature of the boiling water as T_i^m (initial temperature of metal). Allow the thermometer to cool before replacing it in the calorimeter or you use the spare thermometer.
6. Using a pair of crucible tongs, quickly remove the metal from the boiling water and carefully place it in the calorimeter. Close the calorimeter and stir. CAREFULLY not to break the thermometer, it should not touch the metal but must be immersed in the water.
7. When the temperature is constant, record it as T_f^w and T_f^m (final temperature of water and metal respectively).
8. Empty the calorimeter, allow the metal to cool to room temperature and repeat the procedure.

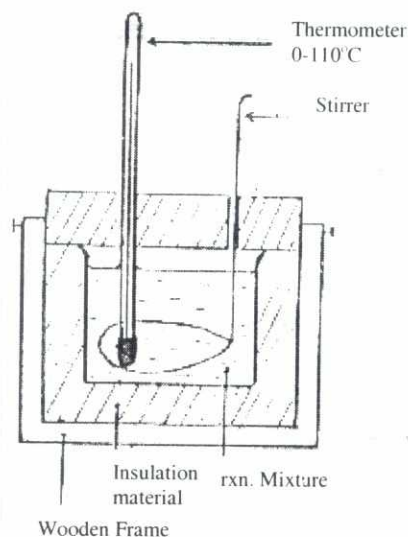

Figure 1. Calorimeter

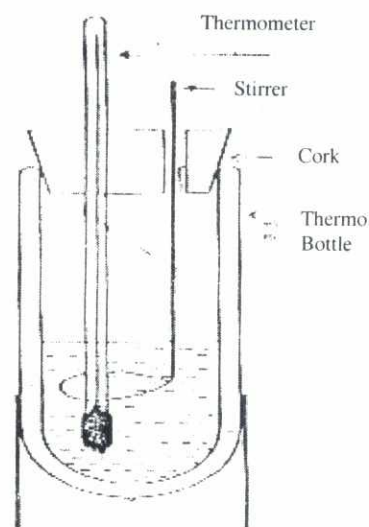

figure 2. Calorimeter

3.4 Results

The following data would have been gathered

Initial temperature of metal	=	T_i^m
Initial temperature of water	=	T_i^w
Final temperature of metal and water	=	T_f^m and T_f^w
Weight of water	=	w_b
Weight metal	=	w^a

3.5 Treatment of Results

Since the heat lost by the metal is equal to the heat gained by the water, the specific heat capacity of the metal can be calculated from the equation:

Heat lost by Cu = heat gained by water

$$-w_m C_m \frac{(T_i^m - T_f^m)}{(T_i^m - T_f^m)} = w_w C_w (T_f^w - T_i^w)$$

(^wm is weight of metal and ^ww is weight of water, while C_m and C_w are specific heat capacities of metal and water respectively). The weight of water may be estimated from the assumption that 1cm³ weighs 1g, while the specific heat capacity may be assumed to be 4.18j/g.deg. (1 cal./g.deg.).

4.0 Experiment 2

Determination of Heat of Neutralisation

4.1 Introduction

The heat of reaction is the amount of heat released or absorbed for a given amount of reactant or product. If the reaction is carried out at constant pressure, the absolute value of the heat of reaction is equal to the absolute value of the enthalpy of reaction. The heat of reaction is measured by the use of calorimeters.

The neutralisation reaction to be studied is the reaction between aqueous sodium hydroxide (NaOH) and aqueous hydrochloric acid (HCl). Sodium and chloride ions do not participate in the reaction since they remain ionized in aqueous solution. The reaction of interest is therefore.

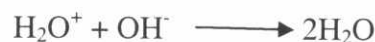

Which is exothermic. The amount of heat released is proportional to the number of moles of acid neutralised, and can be calculated from the volumes and concentrations of reactants used. For a strong acid and a strong base, the heat of neutralisation is almost constant at a value of approximately – 57.5kJ per mole of water produced. This value is almost a constant because the reactants and products are all completely ionized in the water medium.

If however, the acid or the base is weak, the heat of neutralisation would be different from the 57.5kJ per mole. In such a case, the weak acid or base would only be slightly ionized. The reaction taking place rather being a straight forward neutralisation reaction between the acid and the base, would consist of two stages of reaction thus: if the acid is the weak component for example, the first stage will involve the completion of the ionization of the weak acid. It will have a resultant heat change which would be different from the 57.5kJ per mole.



The second stage is the neutralisation proper which is the formation of the salt and water thus;



The net heat change is therefore $(-57.5 + X)$ KJ whose value is usually smaller than 55.7KJ for strong acids and strong bases.

The instruments used for measuring the heat of a reaction is called a calorimeter, which is essentially a well insulated vessel that prevents ready exchange between the contents of the calorimeter and the surrounding environment.

4.2 Requirements

One calorimeter frame
 Two 0 – 110⁰C thermometers
 One stirrer
 100cm³ = 1M NaOH (record exact concentration)
 100cm³ = 1M HCl
 Distilled water
 Crucible tongs

4.3 Procedure

1. Accurately measure out 40cm³ of the NaOH supplied (record its concentration) into a clean dry calorimeter.
2. Into a clean measuring cylinder, measure 40cm³ of the 1M HCl and record its temperature as T_i^a (initial temperature of acid). (*The molarity of the acid is slightly greater than that of the base so that the reaction mixture is acidic at the end of the reaction, to ensure that the reaction was complete*).
3. Rinse and wipe the thermometer, then determine the temperature of the base in the calorimeter and record it as T_i^b
4. Quickly but carefully add all the acid to the base in the calorimeter, replace the lid and stir.

5. When the temperature is constant, record it as the final temperature of both acid T_f^a and base T_f^b .
6. Repeat the determination with fresh samples
7. Calculate the heat of neutralisation for the reaction, using the following assumptions and equations
8. The heat lost by the reaction is equal (but negative) to the heat gained by the solution.
9. Assume density of acid and base = 1g/cm^3

4.4 Results

The following data would have been gathered

Initial temperature of calorimeter acid	=	T_i^a
Initial temperature of base	=	T_i^b
Initial temperature of metal and calorimeter and solution	=	T_f^a and base T_f^b .
Weight of base	=	w_b
Weight acid	=	w^a

4.5 Treatment of Results

Let the heat q , absorbed by the solution, be given by:-

$$q = (\text{weight of acid}) (4.18\text{J/g.deg}) (T_f^a - T_i^a) + (\text{weight of base}) (4.18\text{J/g.deg}) (T_f^b - T_i^b) = Y \text{ joules}$$

Heat of neutralisation

$$\Delta H (\text{KJ/ mole}) = - \frac{q}{1000 \times \text{moles of OH}^- \text{ neutralized}}$$

$$= - Z\text{kJ/mol}$$

Note that the number of moles of OH^- neutralised which is equal to no. moles of acid neutralised, can be calculated from the volume of base used and its molar concentration as we did many times during the discussion on acid-base titrations.

The negative sign indicates an exothermic reaction.

5.0 Conclusion

In this unit, we have been able to determine the specific heat capacity of a substance and also determine the heat of reaction between a strong acid and a strong base. We have found that the heat of reaction from such a pair of reactants is essentially the heat of neutralisation which we found to be -57.5 kJ/mol .

6.0 Summary

In this unit, the following facts were noted.

1. In a chemical reaction, there is usually accompanying the reaction energy transfer.
2. In an exothermic reaction, heat is lost from the reacting materials; in an endothermic reaction, heat is gained by the reacting materials
3. The standard heat of reaction is the amount of heat absorbed or evolved when molar quantities of the stated reactants in the equation react together under standard conditions.
4. The heat of neutralisation is the heat evolved when 1 mole of acid reacts completely with one mole of base to form equivalent mole of salt and water. For a strong acid and strong base pair, this heat is approximately 57.5 kJ/mole . For a pair in which one of them is a weak one, the heat of neutralisation is normally lower than the 57.5 kJ/mol
5. The instrument used to measure the heat of reaction is called a calorimeter.
6. The specific heat capacity is the amount of heat required to raise the temperature of 1 g of the substance through 1°C . On the other hand, the molar heat capacity is the amount of heat required to raise the temperature of one mole of substances through 1°C .



NATIONAL OPEN UNIVERSITY OF NIGERIA

Form QST1 Questionnaire

Dear Student,

While studying the units of this course, you may have found certain portions of the text difficult to comprehend. We wish to know your difficulties and suggestions, in order to improve the course. Therefore, we request you to fill out and send us the following questionnaire, which pertains to this course. If you find the space provided insufficient, kindly use additional sheet.

Course Code: _____ Course Title: _____

1. How many hours did you need for studying each of these units?

Unit	1	2	3	4	5	6	7	8	9	10	11	12	13	14	15
No. of hours															
Unit	16	17	18	19	20	21	22	23	24	25	26	27	28	29	30
No. of hours															

2. Which of these units do you find most difficult to understand?

3. Please give specific problem you find difficult with the unit.

4. How would you like the unit improved?

Please Mail to
The Course Coordinator.....THROUGH the Study Centre Manager
National Open University of Nigeria
Victoria Island,
Lagos.



NATIONAL OPEN UNIVERSITY OF NIGERIA

Form QST2 Questionnaire

In the questions below, we ask you to reflect on your experience of the course as a whole.

- 1 Course Code and Title.....
- 2 Mother tongue
- 3 I am registered for a Degree/Programme
- 4 Why did I choose to take this course?
- 5 Which study unit did I enjoy the most and why?.....
- 6 Which study unit did I enjoy the least and why?.....
- 7 Was the course material easy to understand or difficult?.....
- 8 Which particular topic do I understand better than before and how?.....
- 9 Does the course have any practical applications in the real world, e.g. for the work I currently do?...YES/NO? EXPLAIN.....
- 10 What aspects would I like to know more about or study further?.....
- 11 How could the course be improved?.....

12 Other comments about the course (*Please Tick*).....

Items	Excellent	Very Good	Good	Poor	Give specific examples, if poor
Presentation Quality	<input type="checkbox"/>	<input type="checkbox"/>	<input type="checkbox"/>	<input type="checkbox"/>	_____
Language and Style	<input type="checkbox"/>	<input type="checkbox"/>	<input type="checkbox"/>	<input type="checkbox"/>	_____
Illustrations Used (diagrams, tables, etc.)	<input type="checkbox"/>	<input type="checkbox"/>	<input type="checkbox"/>	<input type="checkbox"/>	_____
Conceptual Clarity	<input type="checkbox"/>	<input type="checkbox"/>	<input type="checkbox"/>	<input type="checkbox"/>	_____
Self Assessment Questions	<input type="checkbox"/>	<input type="checkbox"/>	<input type="checkbox"/>	<input type="checkbox"/>	_____
Facilitators response to TMA Questions	<input type="checkbox"/>	<input type="checkbox"/>	<input type="checkbox"/>	<input type="checkbox"/>	_____

