



**NATIONAL OPEN UNIVERSITY OF NIGERIA**

**SCHOOL OF SCIENCE AND TECHNOLOGY**

**COURSE CODE: CIT 104**

**COURSE TITLE: INTRODUCTION TO COMPUTERS**

# **CIT104: INTRODUCTION TO COMPUTERS**

## **COURSE GUIDE**

**NATIONAL OPEN UNIVERSITY OF  
NIGERIA**

## **Contents**

Introduction

## **The Course**

Course Aims

Course Objectives

## **Working through the Course**

Course Material

Study Units

Text Books

## **Assessment**

Tutor Marked Assignment

End of Semester Examination

## **Summary**

## **INTRODUCTION**

Computer is fast becoming the universal machine of the 21<sup>st</sup> century. Early computers were large in size and too expensive to be owned by individuals. Thus they were confined to the laboratories and few research institutes. They could only be programmed by computer engineers. The basic applications were confined to undertaking complex calculations in science and engineering. Today, computer is no longer confined to the laboratory. Computers and indeed, computing have become embedded in almost every item we use. Computing is fast becoming ubiquitous. Its application transcends science, engineering, communication, space science, aviation, financial institutions, social sciences, humanities, the military, transportation, manufacturing, extractive industries to mention but a few.

Also, early computers were designed to accept numeric data but over the years computers have been developed to accept not only numeric data, computers can now process multimedia data – text, audio and video. The combination of computer technology and communications technology gave birth to what is now widely known as Information and Communication Technologies (ICT). ICT has changed the face of virtually, all fields of human endeavour, ranging from science to engineering, commerce and industry, international trade, transportation, culture and tourism, education and research, among others. Nowadays, literacy is not only measured by the ability to read and write, but also include computer literacy. The wave of globalisation which has been largely propelled by the collapse of barriers of distance between nations and peoples in the world as result of ICT, makes it imperative for the modern man to have at least the basic knowledge of computers. This course is meant to introduce students to the historical evolution of computers, the basic components of computers, and some of its applications in the society.

## **THE COURSE**

This course Guide tells you what to expect from reading this material. The study of computers is not only of academic importance but that of a universal tool of the twenty-first century. This course, therefore, presents a systematic approach to the understanding of computers and its applications.

## **COURSE AIMS**

The aim of this course is to provide students with the basic understanding of the computer and its applications in everyday life.

## **COURSE OBJECTIVES**

The specific objectives of this course are to:

- Provide basic understanding of the historical evolution of the computer, types of computers and the classification of computers.
- Enable the students understand the components of the computer – the hardware and software.
- Help students to identify the different categories of computer software and their uses.
- Introduce students to computer programming with emphasis on the building blocks and stages of programming and writing of computer programs using visual basic.
- Enable students to identify and appreciate the areas of application of computers in the society, thereby stimulating their thought to regard computer as a tool for human use rather than a master.
- Create awareness at the early stage of the study of computers about the potential threats that computer viruses poses to the smooth operations of computers.

## **WORKING THROUGH THE COURSE**

This course involves that you would be required to spend a lot of time to read. The material, though presented in simple language, coherent and in logical sequence, requires diligent study. The material is comprehensive but would require full commitment and dedication to study on the part of the students. You are therefore, advised to avail yourself the opportunity of attending the tutorial sessions where you would have the opportunity of comparing knowledge with your peers.

## **THE COURSE MATERIAL**

You will be provided with the following materials:

Course guide

Modules

Study units

List of recommended textbooks which will serve as compliments to the course material

## **COURSE OUTLINE**

The course is made up of seven modules organized into 19 study units as follows:

### **Module 1: Understanding the computer**

Unit 1: Basic Concepts.

Unit 2: Historical overview of the Computer.

Unit 3: Classification of Computers

### **Module 2: Computer Hardware**

Unit 4: Hardware Components (1)

Unit 5: Hardware Components (2) – Peripheral Devices

Unit 6: Auxiliary Equipment

### **Module 3: Computer Software**

Unit 7: Computer Software (1)

Unit 8: Computer Software (2)

### **Module 4: Programming the Computer**

Unit 9: Computer Languages

Unit 10: Basic Principles of Computer Programming

Unit 11: Flowcharts and Algorithms

### **Module 5: Computer Application Programming**

Unit 12: Programming in Visual Basic (1)

Unit 13: Visual Basic project window

Unit 14: Creating Menu Applications

Unit 15: Analyzing Visual Basic Data

### **Module 6: Areas of Application of Computers**

Unit 16: Application of Computers in Education

Unit 17: Application of Computers in Business and industry

Unit 18: Application of Computers in Government, Military etc

## **Module 7: Threats to the Computer**

### Unit 19: Computer Virus

#### **Synopses of the Study Units**

**Unit 1:** This unit presents the definition of the computer, basic understanding of data processing, the concept of data and information, methods of data processing and the characteristics of a computer.

**Unit 2:** It gives the brief history of computer technology, evolution of computer and the generations of computer.

**Unit 3:** You are introduced to the classification of computers. This involves classification based on size, type of signal and purpose. At the end of the unit you will be able to differentiate between one class of computer from the others.

**Unit 4:** In this unit you will be familiarized with hardware components of the computer. This will enable you to appreciate the importance of each component to the overall smooth operations of the computer.

**Unit 5:** You are introduced to the peripheral devices in this unit. Also, you will be able to get deeper understanding of the functions of the input and output units. The knowledge acquired in this unit will give you a guide on the type of input and output units suitable to a particular computing environment.

**Unit 6:** The unit discusses the computer auxiliary equipment such as air conditioner, voltage stabilizer and the uninterruptible Power Supply System (UPS).

**Unit 7:** This unit introduces the computer software in some details. You will learn about the system software, language translators such as compilers and the utility software.

**Unit 8:** This unit builds on the knowledge acquired in the previous unit by this discussing various types of language translators, utility programs and application programs in greater detail.

**Unit 9:** In this unit you will learn about computer programming languages such as low level language (machine language and assemblers) and the high level languages.

**Unit 10:** You will be introduced to computer programming in this unit. Topics covered include the concept of problem solving with computers, principles of programming and stages of programming.

**Unit 11:** This unit advances further on unit 10 by discussing the use of flowchart and algorithms in computer programming. These two concepts are essential ingredients to the writing of well structured computer programs.

**Unit 12:** This unit begins our discussions on programming the computer in Visual Basic. Units 12 through 15 are dedicated to this subject. The discussions are practical in nature. The materials presented in these four units are in the form of hands-on-practice. You will benefit more and in fact, enjoy it better if you can try them using a personal computer. The steps involved are simple and explicit. By the time you run through the four units you should be able to write simple visual basic application programs. Specifically, unit 12 introduces the concept of working with graphical objects, general visual basic programming concepts, how to design a project from application wizard; and how to use toolbox.

**Unit 13:** In this unit you will learn about the visual basic project window. This will enable you gain more mastery of the visual basic programming environment.

**Unit 14:** In this unit you will learn how to create menu applications. The menu system is one of the high points of object oriented programming languages. It makes the application user-friendly and interactive. This unit therefore, equip you with the principles and steps involved in creating visual basic applications with menu.

**Unit 15:** This unit concludes the discussions on programming computers in visual basic. Specifically, this unit takes you through the analysis of visual basic data. If you have truly followed all the principles and steps discussed in the three previous units you should at this stage be able to plan, design, code and implement a simple but complete visual basic application.

**Unit 16:** This unit begins the series of presentations on the areas of application of computers in the society. The main aim is to identify some areas of application to the society at large. It is also meant to enlighten you on the various job opportunities for computer literate persons in the society. Specifically, in this unit, you are presented with detailed discussion on the areas of application of computers in education.

**Unit 17:** This unit furthers the discussion on the areas of application of computers by presenting in greater details its application in business and industry. It discusses application of computer in the development and operations of payroll, inventory control, auditing operations, personnel record keeping, preparation of customer utility bills and



payment orders, management information system, high quality production control, point of sale service, financial market and publishing industry.

**Unit 18:** This unit concludes the discussions on the areas of application of computers with particular reference to its application in science and engineering, health care, transport and communications, recreation, government and the military.

**Unit 19:** This is the concluding unit of this course. It presents discussion on computer virus as one of the major threats to the smooth operations of the computers. Detailed discussions on computer virus, its mode of transmission, detection, prevention and cure, are presented.

### **TEXT BOOKS**

More recent editions of these books are recommended for further reading.

Akinyokun, O.C, (1999). *Principles and Practice of Computing Technology*.

International Publishers Limited, Ibadan.

Balogun, V.F., Daramola, O.A., Obe, O.O., Ojokoh, B.A., and Oluwadare S.A., (2006).

*Introduction to Computing: A Practical Approach*. Tom-Ray Publications, Akure.

Chuley, J.C. (1987). *Introduction to Low Level Programming for Microprocessors*.

Macmillan Education Ltd.

Francis Scheid (1983). *Schaum's Outline Series: Computers and Programming*.

Mcgraw-Hill Book Company, Singapore.

Gray S. Popkin and Arthur H. Pike (1981). *Introduction to Data Processing with*

*BASIC*, 2<sup>nd</sup> edition, Houghton Mifflin Company, Boston.

Oliver E.C. and Chapman R.J. (1986). *Data Processing*, Seventh Edition. ELBS/DP

Publications.

Richard H. Austing and Lillian Cassel (1986). *Computers in Focus*. Books/Cole

Publication Company. Monterey, California

Tunji and Dokun (1993). *Data Processing, Principles and Concepts*. Informatics Books,

Lagos.

In addition, to these books, you can browse on the internet to get additional materials on the topics covered in this course.

## **ASSESSMENT**

There are two components of assessment for this course. The Tutor Marked Assignment (TMA), and the end of course examination.

### **TUTOR MARKED ASSIGNMENT**

The TMA is the continuous assessment component of your course. It accounts for 30% of the total score. You will be given six (6) TMA's to answer. They must be answered before you are allowed to sit for the end of course examination. The TMA's would be given to you by your facilitators at the appropriate time during the course. They are returned to you after you have done the assignment.

### **END OF COURSE EXAMINATION**

This examination concludes the assessment for the course. It constitutes 70% of the whole course. You will be informed of the time for the examination. It may or not coincide with the university semester examination.

## **SUMMARY**

This course intends to introduce you to the basic understanding of computers and its application in various areas of human endeavour. By the time you complete studying this course, you should be able to answer basic questions such as:

- What is computer?
- What are the evolutionary trends in the development of the computer?
- What are the different components of computer?
- What are the different categories of computer software?
- What are the areas of application of computers in the society?
- How could you use computer to create a user-friendly, menu-driven and interactive applications?
- What are the threats to the smooth operations of the computer?
- How can you detect, prevent and cure computer viruses?

We wish you success in this course. We do hope that this course will give you a good head start in the understanding and use of computers.  
Best wishes as you enjoy the course.

**CIT104: INTRODUCTION TO COMPUTERS (2 UNITS)**

**COURSE MANUAL**

**NATIONAL OPEN UNIVERSITY OF NIGERIA**

## **MODULE 1: UNDERSTANDING THE COMPUTER**

In this module we shall discuss the following topics:

- Basic concepts
- Historical overview of the development of computers
- Generations of computers
- Classification of computers

### **STUDY UNIT 1: BASIC CONCEPTS**

#### **Table of Contents**

Definition of the computer

Basic understanding of data processing

The concept of data and information

Methods of data processing

Characteristics of a computer

#### **1.0 Introduction**

Computer is fast becoming the universal machine of the 21<sup>st</sup> century. Early computers were large in size and too expensive to be owned by individuals. Thus they were confined to the laboratories and few research institutes. They could only be programmed by computer engineers. The basic applications were confined to undertaking complex

calculations in science and engineering. Today, computer is no longer confined the laboratory. Computers and indeed, computing have become embedded in almost every item we use. Computing is fast becoming ubiquitous. Its application transcends science, engineering, communication, space science, aviation, financial institutions, social sciences, humanities, the military, transportation, manufacturing, extractive industries to mention but a few. This unit presents the background information about computers.

## 2.0 Objectives

The objective of this unit is to enable students understand the following basic concepts:

- (a) Definition of the computer
- (b) Basic understanding of data processing
- (c) The concept of data and information
- (d) Methods of data processing
- (e) Characteristics of a computer

## 3.0 Definitions

**Computer:** A computer is basically defined as a tool or machine used for processing data to give required information. It is capable of:

- a. taking input data through the keyboard (input unit)
- b. storing the input data in a diskette, hard disk or other medium
- c. processing it at the central processing unit (CPU) and
- d. giving out the result (output) on the screen or the Visual Display Unit (VDU).

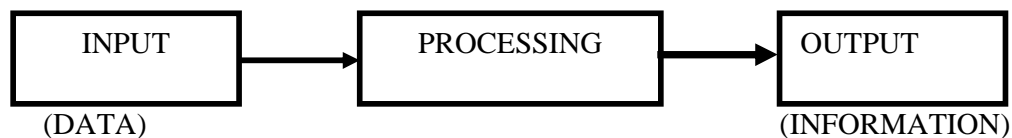

**Fig. 1.0: Schematic diagram to define a computer**

**Data:** The term data is referred to facts about a person, object or place e.g. name, age, complexion, school, class, height etc.

**Information:** Is referred to as processed data or a meaningful statement e.g. Net pay of workers, examination results of students, list of successful candidates in an examination or interview etc.

**3.1 Methods of Data Processing**

The following are the three major methods that have been widely used for data processing over the years:

- a. Manual method
- b. Mechanical method and
- c. Computer method.

**Manual Method**

The manual method of data processing involves the use of chalk, wall, pen pencil and the like. These devices, machine or tools facilitate human efforts in recording, classifying, manipulating, sorting and presenting data or information. The manual data processing operations entail considerable manual efforts. Thus, manual method is cumbersome, tiresome, boring, frustrating and time consuming. Furthermore, the processing of data by the manual method is likely to be affected by human errors. When there are errors, then the reliability, accuracy, neatness, tidiness, and validity of the data would be in doubt. The manual method does not allow for the processing of large volume of data on a regular and timely basis.

**Mechanical Method**

The mechanical method of data processing involves the use of machines such as typewriter, roneo machines, adding machines and the like. These machines facilitate

human efforts in recording, classifying, manipulating, sorting and presenting data or information. The mechanical operations are basically routine in nature. There is virtually no creative thinking. The mechanical operations are noisy, hazardous, error prone and untidy. The mechanical method does not allow for the processing of large volume of data continuously and timely.

### **Computer Method**

**The computer method of carrying out data processing has the following major features:**

- a. Data can be steadily and continuously processed
- b. The operations are practically not noisy
- c. There is a store where data and instructions can be stored temporarily and permanently.
- d. Errors can be easily and neatly corrected.
- e. Output reports are usually very neat, decent and can be produced in various forms such as adding graphs, diagrams, pictures etc.
- f. Accuracy and reliability are highly enhanced.

Below are further attributes of a computer which makes it to be an indispensable tool for human being:

### **3.2 Characteristics of a Computer**

#### **Characteristics of Computer**

1. **Speed:** The computer can manipulate large data at incredible speed and response time can be very fast.
2. **Accuracy:** Its accuracy is very high and its consistency can be relied upon. Errors committed in computing are mostly due to human rather than technological weakness. There are in-built error detecting schemes in the computer.
3. **Storage:** It has both internal and external storage facilities for holding data and instructions. This capacity varies from one machine to the other. Memories are built up in K(Kilo) modules where  $K = 1024$  memory locations.



4. **Automatic:** Once a program is in the computer's memory, it can run automatically each time it is opened. The individual has little or no instruction to give again.
5. **Reliability:** Being a machine, a computer does not suffer human traits of tiredness and lack of concentration. It will perform the last job with the same speed and accuracy as the first job every time even if ten million jobs are involved.
6. **Flexibility:** It can perform any type of task once it can be reduced to logical steps. Modern computers can be used to perform a variety of functions like on-line processing, multi-programming, real time processing etc.

### 3.3 The Computing System

The computing system is made up of the computer system, the user and the environment in which the computer is operated.

#### The Computer System

The computer system is made up of the hardware and the software.

#### The Hardware

The computer hardware comprises the input unit, the processing unit and the output unit.

The input unit comprises those media through which data is fed into the computer.

Examples include the keyboard, mouse, joystick, trackball, scanner etc.

The processing unit is made up of the Arithmetic and Logic Unit (ALU), the control unit and the main memory. The main memory also known as the primary memory is made up of the Read Only Memory (ROM) and the Random Access Memory (RAM).

The output unit is made up of those media through which data, instructions for processing the data (program), and the result of the processing operation are displayed

for the user to see. Examples of output unit are the monitor (Visual Display Unit) and the printer.

### **Software**

Computer software are the series of instructions that enable the computer to perform a task or group of tasks. A program is made up of group of instructions to perform a task. Series of programs linked together make up software. Computer programs could be categorized into system software, utility software, and application programs.

### **Computer Users**

Computer users are the different categories of personnel that operates the computer. We have expert users and casual users. The expert users could be further categorized into computer engineers, computer programmers and computer operators.

### **The Computing Environment**

The computing environment ranges from the building housing the other elements of the computing system namely the computer and the users, the furniture, auxiliary devices such as the voltage stabilizer, the Uninterruptible Power Supply System (UPS), the fans, the air conditioners etc. The schematic diagram of the computing system is presented in Fig. 1.2a. to Fig. 1.2e

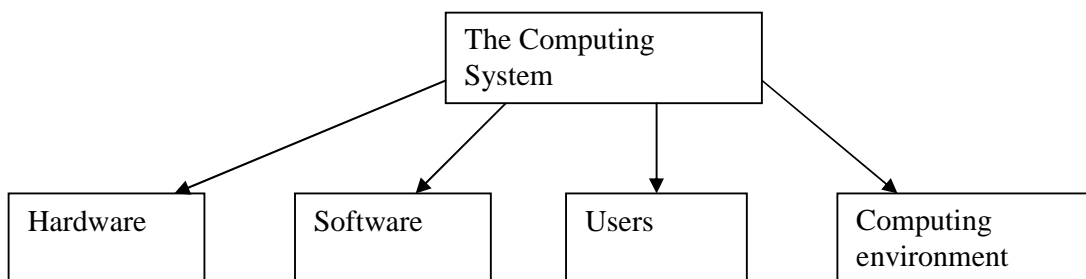

Fig. 1.2a: Schematic diagram of the computing system

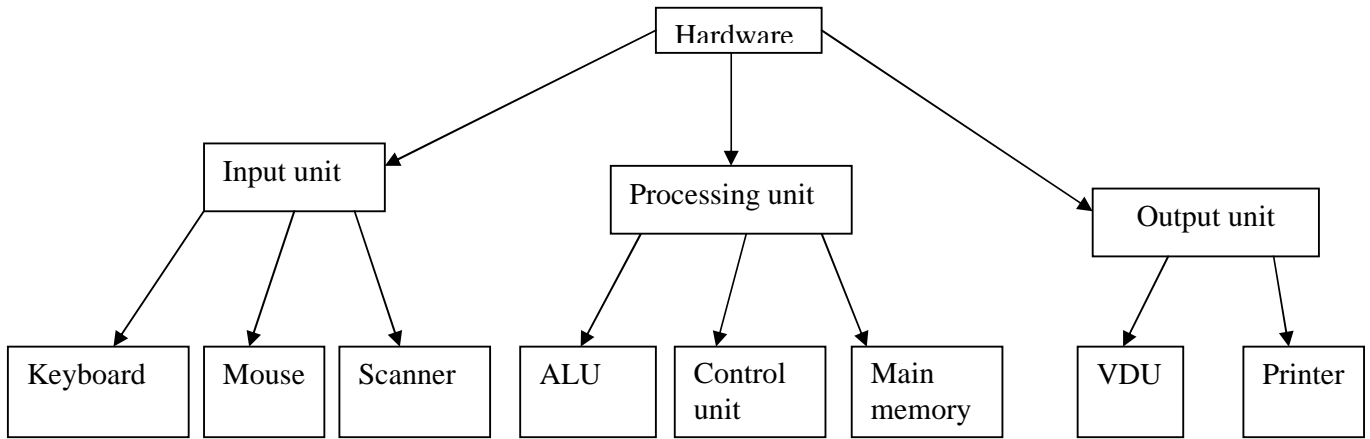

Fig. 1.2b: Computer hardware

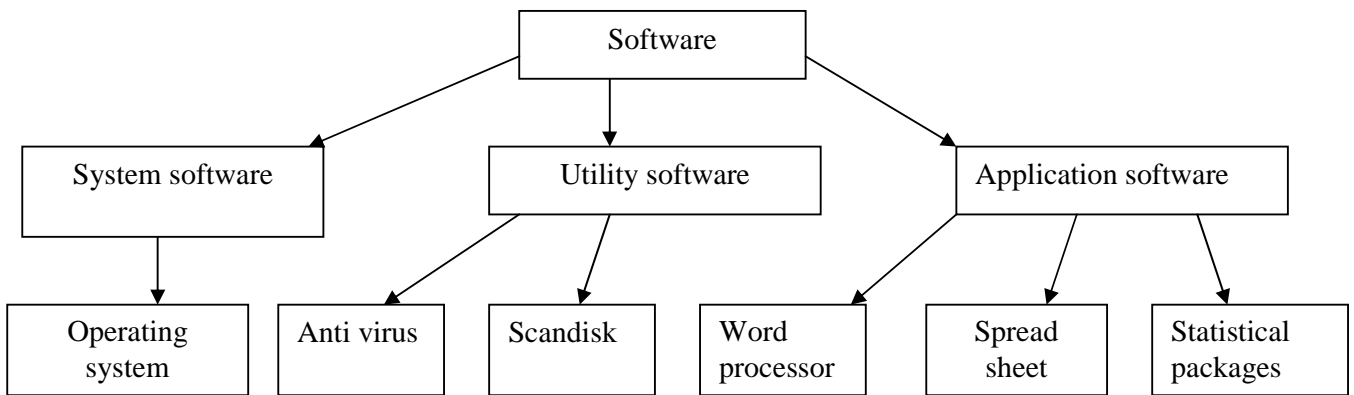

Fig. 1.2c: Computer software

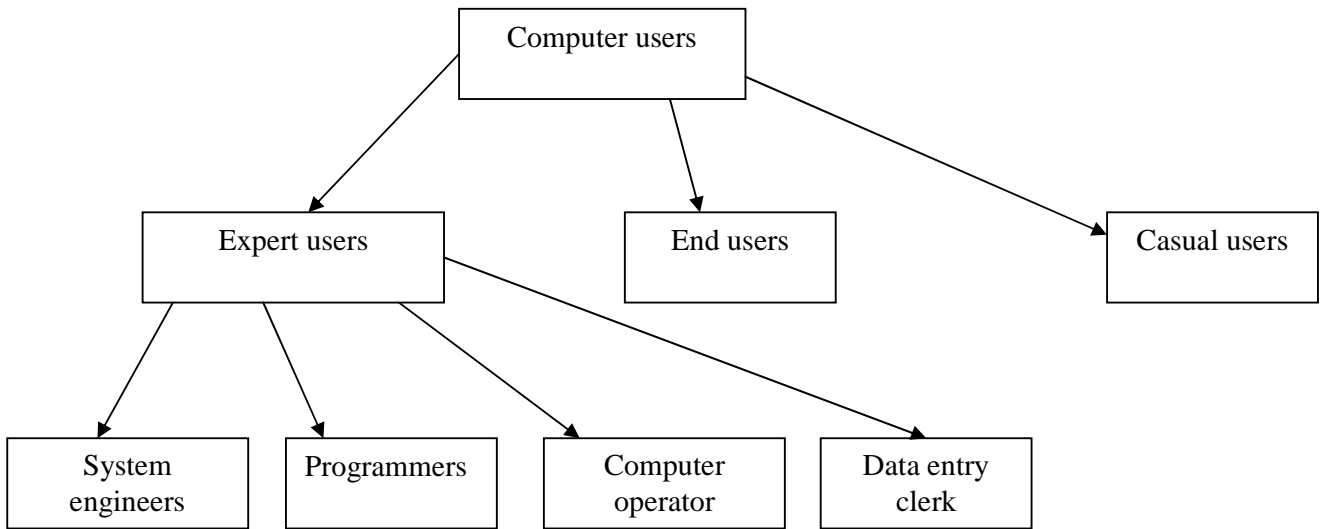

Fig. 1.2d: Computer users

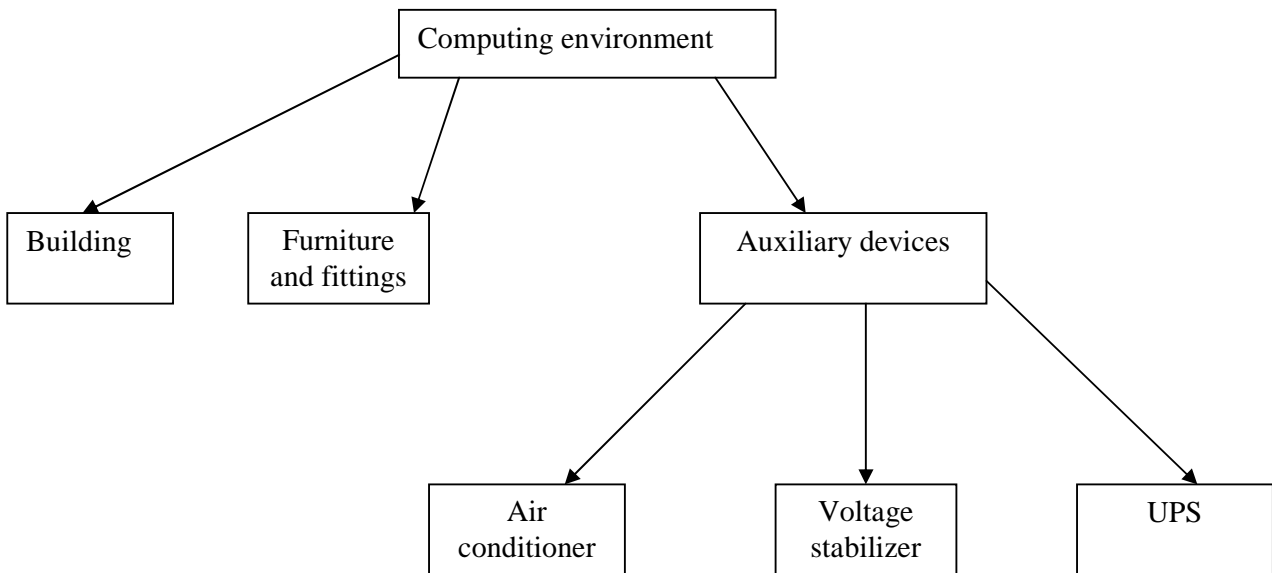

Fig. 1.2e: Computing environment

#### **4.0 Conclusion**

The computer is a machine used for a variety of purposes. Its use transcends all areas of human endeavour owing to the advantages of computer method of data processing over the manual and mechanical methods of data processing.

#### **5.0 Summary**

In this unit we have learnt the following:

- i. Computer is any electronic device that can accept data, process it and produce an output.
- ii. The computer method of data processing is superior to the manual and mechanical methods of data processing.
- iii. The computing system is made up of the computer system, the users and the computing environment.

#### **6.0 Tutor Marked Assignment**

1a. What is a computer?

1b. What are the advantages of computer method of data processing over manual and mechanical methods of data processing.

2. Draw the schematic diagram of a computing system and describe each of the components.

#### **7.0 Further reading and other Resources.**

Akinyokun, O.C, (1999). Principles and Practice of Computing Technology.

International Publishers Limited, Ibadan.

Balogun, V.F., Daramola, O.A., Obe, O.O., Ojokoh, B.A., and Oluwadare S.A., (2006).

Introduction to Computing: A Practical Approach. Tom-

Ray Publications, Akure.

## **STUDY UNIT 2: HISTORICAL OVERVIEW OF THE COMPUTER**

### **Table of content**

A brief history of computer technology.

Evolution of the computer.

Generations of computer.

### **1.0 Introduction**

The computer as we know it today has evolved over the ages. An attempt is made in this unit to present in chronological order the various landmarks and milestones in the development of the computer. Based on the milestone achievement of each era the computer evolution is categorized into generations. The generational classification however, is not rigid as we may find one generation eating into the next.

### **2.0 Objectives**

The objective of this unit is to enable the student to know the processes leading to the emergence of the modern computer. There can be no present without the past just as the future depends on the present. By the end of this unit, students should be able to appreciate and visualize the direction of research in computer technology in the nearby future.

### **3.0 A Brief History of Computer Technology**

A complete history of computing would include a multitude of diverse devices such as the ancient Chinese abacus, the Jacquard loom (1805) and Charles Babbage's "analytical engine" (1834). It would also include discussion of mechanical, analog and digital computing architectures. As late as the 1960s, mechanical devices, such as the Marchant calculator, still found widespread application in science and engineering. During the early days of electronic computing devices, there was much discussion about the relative merits of analog vs. digital computers. In fact, as late as the 1960s, analog computers were routinely used to solve systems of finite difference equations arising in oil reservoir

modeling. In the end, digital computing devices proved to have the power, economics and scalability necessary to deal with large scale computations. Digital computers now dominate the computing world in all areas ranging from the hand calculator to the supercomputer and are pervasive throughout society. Therefore, this brief sketch of the development of scientific computing is limited to the area of digital, electronic computers.

The evolution of digital computing is often divided into generations. Each generation is characterized by dramatic improvements over the previous generation in the technology used to build computers, the internal organization of computer systems, and programming languages. Although not usually associated with computer generations, there has been a steady improvement in algorithms, including algorithms used in computational science. The following history has been organized using these widely recognized generations as mileposts.

### **3.1 First Generation Electronic Computers (1937 – 1953)**

Three machines have been promoted at various times as the first electronic computers. These machines used electronic switches, in form of vacuum tubes, instead of electromechanical relays. In principle the electronic switches were more reliable, since they would have no moving parts that would wear out, but technology was still new at that time and the tubes were comparable to relays in reliability. Electronic components had one major benefit, however: they could “open” and “close” about 1,000 times faster than mechanical switches.

The earliest attempt to build an electronic computer was by J. V. Atanasoff, a professor of physics and mathematics at Iowa State, in 1937. Atanasoff set out to build a machine that would help his graduate students solve systems of partial differential equations. By 1941, he and graduate student Clifford Berry had succeeded in building a machine that could solve 29 simultaneous equations with 29 unknowns. However, the machine was not programmable, and was more of an electronic calculator.

A second early electronic machine was Colossus, designed by Alan Turing for the British military in 1943. This machine played an important role in breaking codes used by the German army in World War II. Turing's main contribution to the field of computer science was the idea of the Turing Machine, a mathematical formalism widely used in the study of computable functions. The existence of Colossus was kept secret until long after the war ended, and the credit due to Turing and his colleagues for designing one of the first working electronic computers was slow in coming.

The first general purpose programmable electronic computer was the Electronic Numerical Integrator and Computer (ENIAC), built by J. Presper Eckert and John V. Mauchly at the University of Pennsylvania. Work began in 1943, funded by the Army Ordnance Department, which needed a way to compute ballistics during World War II. The machine wasn't completed until 1945, but then it was used extensively for calculations during the design of the hydrogen bomb. By the time it was decommissioned in 1955 it had been used for research on the design of wind tunnels, random number generators, and weather prediction. Eckert, Mauchly, and John Von Neumann, a consultant to the ENIAC project, began work on a new machine before ENIAC was finished. The main contribution of EDVAC, their new project, was the



notion of a stored program. There is some controversy over who deserves the credit for this idea, but no one knows how important the idea was to the future of general purpose computers. ENIAC was controlled by a set of external switches and dials; to change the program required physically altering the settings on these controls. These controls also limited the speed of the internal electronic operations. Through the use of a memory that was large enough to hold both instructions and data, and using the program stored in memory to control the order of arithmetic operations, EDVAC was able to run orders of magnitude faster than ENIAC. By storing instructions in the same medium as data, designers could concentrate on improving the internal structure of the machine without worrying about matching it to the speed of an external control.

Regardless of who deserves the credit for the stored program idea, the EDVAC project is significant as an example of the power of interdisciplinary projects that characterize modern computational science. By recognizing that functions, in the form of a sequence of instructions for a computer, can be encoded as numbers, the EDVAC group knew the instructions could be stored in the computer's memory along with numerical data. The notion of using numbers to represent functions was a key step used by Goedel in his incompleteness theorem in 1937, work which Von Neumann, as a logician, was quite familiar with. Von Neumann's background in logic, combined with Eckert and Mauchly's electrical engineering skills, formed a very powerful interdisciplinary team.

Software technology during this period was very primitive. The first programs were written out in machine code, i.e. programmers directly wrote down the numbers that corresponded to the instructions they wanted to store in memory. By the 1950s programmers were using a symbolic notation, known as assembly language, then hand-

translating the symbolic notation into machine code. Later programs known as assemblers performed the translation task.

As primitive as they were, these first electronic machines were quite useful in applied science and engineering. Atanasoff estimated that it would take eight hours to solve a set of equations with eight unknowns using a Marchant calculator, and 381 hours to solve 29 equations for 29 unknowns. The Atanasoff-Berry computer was able to complete the task in under an hour. The first problem run on the ENIAC, a numerical simulation used in the design of the hydrogen bomb, required 20 seconds, as opposed to forty hours using mechanical calculators. Eckert and Mauchly later developed what was arguably the first commercially successful computer, the UNIVAC; in 1952, 45 minutes after the polls closed and with 7% of the vote counted, UNIVAC predicted Eisenhower would defeat Stevenson with 438 electoral votes (he ended up with 442).

### **3.2 Second Generation (1954 – 1962)**

The second generation saw several important developments at all levels of computer system design, from the technology used to build the basic circuits to the programming languages used to write scientific applications.

Electronic switches in this era were based on discrete diode and transistor technology with a switching time of approximately 0.3 microseconds. The first machines to be built with this technology include TRADIC at Bell Laboratories in 1954 and TX-0 at MIT's Lincoln Laboratory. Memory technology was based on magnetic cores which could be accessed in random order, as opposed to mercury delay lines, in which data was stored as

an acoustic wave that passed sequentially through the medium and could be accessed only when the data moved by the I/O interface.

Important innovations in computer architecture included index registers for controlling loops and floating point units for calculations based on real numbers. Prior to this accessing successive elements in an array was quite tedious and often involved writing self-modifying code (programs which modified themselves as they ran; at the time viewed as a powerful application of the principle that programs and data were fundamentally the same, this practice is now frowned upon as extremely hard to debug and is impossible in most high level languages). Floating point operations were performed by libraries of software routines in early computers, but were done in hardware in second generation machines.

During this second generation many high level programming languages were introduced, including FORTRAN (1956), ALGOL (1958), and COBOL (1959). Important commercial machines of this era include the IBM 704 and 7094. The latter introduced I/O processors for better throughput between I/O devices and main memory.

The second generation also saw the first two supercomputers designed specifically for numeric processing in scientific applications. The term “supercomputer” is generally reserved for a machine that is an order of magnitude more powerful than other machines of its era. Two machines of the 1950s deserve this title. The Livermore Atomic Research Computer (LARC) and the IBM 7030 (aka Stretch) were early examples of machines that overlapped memory operations with processor operations and had primitive forms of parallel processing.

### **3.3 Third Generation (1963 – 1972)**

The third generation brought huge gains in computational power. Innovations in this era include the use of integrated circuits, or ICs (semiconductor devices with several transistors built into one physical component), semiconductor memories starting to be used instead of magnetic cores, microprogramming as a technique for efficiently designing complex processors, the coming of age of pipelining and other forms of parallel processing, and the introduction of operating systems and time-sharing.

The first ICs were based on small-scale integration (SSI) circuits, which had around 10 devices per circuit (or “chip”), and evolved to the use of medium-scale integrated (MSI) circuits, which had up to 100 devices per chip. Multilayered printed circuits were developed and core memory was replaced by faster, solid state memories. Computer designers began to take advantage of parallelism by using multiple functional units, overlapping CPU and I/O operations, and pipelining (internal parallelism) in both the instruction stream and the data stream. In 1964, Seymour Cray developed the CDC 6600, which was the first architecture to use functional parallelism. By using 10 separate functional units that could operate simultaneously and 32 independent memory banks, the CDC 6600 was able to attain a computation rate of 1 million floating point operations per second (1 Mflops). Five years later CDC released the 7600, also developed by Seymour Cray. The CDC 7600, with its pipelined functional units, is considered to be the first vector processor and was capable of executing at 10 Mflops. The IBM 360/91, released during the same period, was roughly twice as fast as the CDC 660. It employed instruction look ahead, separate floating point and integer functional units and pipelined instruction stream. The IBM 360-195 was comparable to the CDC 7600, deriving much of its performance from a very fast cache memory. The SOLOMON computer,

developed by Westinghouse Corporation, and the ILLIAC IV, jointly developed by Burroughs, the Department of Defense and the University of Illinois, was representative of the first parallel computers. The Texas Instrument Advanced Scientific Computer (T I-ASC) and the STAR-100 of CDC were pipelined vector processors that demonstrated the viability of that design and set the standards for subsequent vector processors.

Early in this, third generation Cambridge and the University of London cooperated in the development of CPL (Combined Programming Language, 1963). CPL was, according to its authors, an attempt to capture only the important features of the complicated and sophisticated ALGOL. However, the ALGOL, CPL was large with many features that were hard to learn. In an attempt at further simplification, Martin Richards of Cambridge developed a subset of CPL called BCPL (Basic Computer Programming Language, 1967).

### **3.4 Fourth Generation (1972 – 1984)**

The next generation of computer systems saw the use of large scale integration (LSI – 1000 devices per chip) and very large scale integration (VLSI – 100,000 devices per chip) in the construction of computing elements. At this scale entire processors will fit onto a single chip, and for simple systems the entire computer (processor, main memory, and I/O controllers) can fit on one chip. Gate delays dropped to about 10ns per gate.

Semiconductor memories replaced core memories as the main memory in most systems; until this time the use of semiconductor memory in most systems was limited to registers and cache. During this period, high speed vector processors, such as the CRAY 1, CRAY X-MP and CYBER 205 dominated the high performance computing scene.

Computers with large main memory, such as the CRAY 2, began to emerge. A variety of parallel architectures began to appear; however, during this period the parallel computing efforts were of a mostly experimental nature and most computational science was carried out on vector processors. Microcomputers and workstations were introduced and saw wide use as alternatives to time-shared mainframe computers.

Developments in software include very high level languages such as FP (functional programming) and Prolog (programming in logic). These languages tend to use a *declarative* programming style as opposed to the *imperative* style of Pascal, C, FORTRAN, et al. In a declarative style, a programmer gives a mathematical specification of what should be computed, leaving many details of how it should be computed to the compiler and/or runtime system. These languages are not yet in wide use, but are very promising as notations for programs that will run on massively parallel computers (systems with over 1,000 processors). Compilers for established languages started to use sophisticated optimization techniques to improve code, and compilers for vector processors were able to vectorize simple loops (turn loops into single instructions that would initiate an operation over an entire vector).

Two important events marked the early part of the third generation: the development of the C programming language and the UNIX operating system, both at Bell Labs. In 1972, Dennis Ritchie, seeking to meet the design goals of CPL and generalize Thompson's B, developed the C language. Thompson and Ritchie then used C to write a version of UNIX for the DEC PDP-11. This C-based UNIX was soon ported to many different computers, relieving users from having to learn a new operating system each

time they change computer hardware. UNIX or a derivative of UNIX is now a de facto standard on virtually every computer system.

An important event in the development of computational science was the publication of the Lax report. In 1982, the US Department of Defense (DOD) and National Science Foundation (NSF) sponsored a panel on Large Scale Computing in Science and Engineering, chaired by Peter D. Lax. The Lax Report stated that aggressive and focused foreign initiatives in high performance computing, especially in Japan, were in sharp contrast to the absence of coordinated national attention in the United States. The report noted that university researchers had inadequate access to high performance computers. One of the first and most visible of the responses to the Lax report was the establishment of the NSF supercomputing centers. Phase I on this NSF program was designed to encourage the use of high performance computing at American universities by making cycles and training on three (and later six) existing supercomputers immediately available. Following this Phase I stage, in 1984 – 1985 NSF provided funding for the establishment of five Phase II supercomputing centers.

The Phase II centers, located in San Diego (San Diego supercomputing Centre); Illinois (National Center for Supercomputing Applications); Pittsburgh (Pittsburgh Supercomputing Center); Cornell (Cornell Theory Center); and Princeton (John Von Neumann Center), have been extremely successful at providing computing time on supercomputers to the academic community. In addition they have provided many valuable training programs and have developed several software packages that are available free of charge. These Phase II centers continue to augment the substantial high

performance computing efforts at the National Laboratories, especially the Department of Energy (DOE) and NASA sites.

### **3.5 Fifth Generation (1984 – 1990)**

The development of the next generation of computer systems is characterized mainly by the acceptance of parallel processing. Until this time, parallelism was limited to pipelining and vector processing, or at most to a few processors sharing jobs. The fifth generation saw the introduction of machines with hundreds of processors that could all be working on different parts of a single program. The scale of integration in semiconductors continued at an incredible pace, by 1990 it was possible to build chips with a million components – and semiconductor memories became standard on all computers.

Other new developments were the widespread use of computer networks and the increasing use of single-user workstations. Prior to 1985, large scale parallel processing was viewed as a research goal, but two systems introduced around this time are typical of the first commercial products to be based on parallel processing. The Sequent Balance 8000 connected up to 20 processors to a single shared memory module (but each processor had its own local cache). The machine was designed to compete with the DEC VAX-780 as a general purpose Unix system, with each processor working on a different user's job. However, Sequent provided a library of subroutines that would allow programmers to write programs that would use more than one processor, and the machine was widely used to explore parallel algorithms and programming techniques.



The Intel iPSC -1, nicknamed “the hypercube”, took a different approach. Instead of using one memory module, Intel connected each processor to its own memory and used a network interface to connect processors. This distributed memory architecture meant memory was no longer a bottleneck and large systems (using more processors) could be built. The largest iPSC-1 had 128 processors. Toward the end of this period, a third type of parallel processor was introduced to the market. In this style of machine, known as a *data-parallel* or SIMD, there are several thousand very simple processors. All processors work under the direction of a single control unit; i.e. if the control unit says “add a to b” then all processors find their local copy of a and add it to their local copy of b. Machines in this class include the Connection Machine from Thinking Machines, Inc., and the MP-1 from MasPar, Inc.

Scientific computing in this period was still dominated by vector processing. Most manufacturers of vector processors introduced parallel models, but there were very few (two to eight) processors in these parallel machines. In the area of computer networking, both wide area network (WAN) and local area network (LAN) technology developed at a rapid pace, stimulating a transition from the traditional mainframe computing environment towards a distributed computing environment in which each user has their own workstation for relatively simple tasks (editing and compiling programs, reading mail) but sharing large, expensive resources such as file servers and supercomputers. RISC technology (a style of internal organization of the CPU) and plummeting costs for RAM brought tremendous gains in computational power of relatively low cost workstations and servers. This period also saw a marked increase in both the quality and quantity of scientific visualization.

### **3.6 Sixth Generation (1990 to date )**

Transitions between generations in computer technology are hard to define, especially as they are taking place. Some changes, such as the switch from vacuum tubes to transistors, are immediately apparent as fundamental changes, but others are clear only in retrospect. Many of the developments in computer systems since 1990 reflect gradual improvements over established systems, and thus it is hard to claim they represent a transition to a new “generation”, but other developments will prove to be significant changes.

In this section, we offer some assessments about recent developments and current trends that we think will have a significant impact on computational science.

This generation is beginning with many gains in parallel computing, both in the hardware area and in improved understanding of how to develop algorithms to exploit diverse, massively parallel architectures. Parallel systems now compete with vector processors in terms of total computing power and most especially parallel systems to dominate the future.

Combinations of parallel/vector architectures are well established, and one corporation (Fujitsu) has announced plans to build a system with over 200 of its high and vector processors. Manufacturers have set themselves the goal of achieving teraflops ( $10^{12}$  arithmetic operations per second) performance by the middle of the decade, and it is clear this will be obtained only by a system with a thousand processors or more. Workstation technology has continued to improve, with processor designs now using a combination of RISC, pipelining, and parallel processing. As a result it is now possible

to procure a desktop workstation that has the same overall computing power (100 megaflops) as fourth generation supercomputers. This development has sparked an interest in heterogeneous computing: a program started on one workstation can find idle workstations elsewhere in the local network to run parallel subtasks.

One of the most dramatic changes in the sixth generation is the explosive growth of wide area networking. Network bandwidth has expanded tremendously in the last few years and will continue to improve for the next several years. T1 transmission rates are now standard for regional networks, and the national “backbone” that interconnects regional networks uses T3. networking technology is becoming more widespread than its original strong base in universities and government laboratories as it is rapidly finding application in K-12 education, community networks and private industry. A little over a decade after the warning voiced in the Lax report, the future of a strong computational science infrastructure is bright.

#### **4.0 Conclusion**

The development of computer span through many generations with each generations chronicling the landmark achievements of the period.

#### **5.0 Summary**

In this unit we have learnt that the development of computer spanned through six generations.

#### **6.0 Tutor Marked Assignment**

- a. Outline the major landmarks of the fourth and the fifth generations of computers.
- b. Explain what is meant by stored program computer architecture.

## **7.0 References and Further Reading**

Akinyokun, O.C, (1999). Principles and Practice of Computing Technology.

International Publishers Limited, Ibadan.

Balogun, V.F., Daramola, O.A., Obe, O.O., Ojokoh, B.A., and Oluwadare S.A., (2006).

Introduction to Computing: A Practical Approach. Tom-Ray Publications, Akure.

Larry Long (1984). *Introduction to Computers and Information Processing*. Prentice-Hall Inc., New Jersey.

Tunji and Dokun (1993). *Data Processing, Principles and Concepts*. Informatics Books, Lagos.

## **STUDY UNIT 3: CLASSIFICATION OF COMPUTERS**

### **Table of contents**

Categories of computers

Classification based on signal type

- Digital computer
- Analog computer
- Hybrid computer

Classification by purpose

- Special purpose
- General purpose

Classification by capacity

- Main frame
- Mini computers
- Micro computers

### **1.0 Introduction**

The computer has passed through many stages of evolution from the days of the mainframe computers to the era of microcomputers. Computers have been classified based on different criteria. In this unit, we shall classify computers based on three popular methods.

### **2.0 Objectives**

The objectives of this unit are to:

- i. Classify computers based on size, type of signal and purpose.
- ii. Study the features that differentiate one class of the computer from the others.

### **3.0 Categories of Computers**

Although there are no industry standards, computers are generally classified in the following ways:

#### **3.1 Classification Based On Signal Type**

There are basically three types of electronic computers. These are the Digital, Analog and Hybrid computers.

##### **Digital Computer**

Represent its variable in the form of digits. It counts the data it deals with, whether representing numbers, letters or other symbols, are converted into binary form on input to the computer. The data undergoes a processing after which the binary digits are converted back to alpha numeric form for output for human use. Because of the fact that business applications like inventory control, invoicing and payroll deal with discrete values (separate, disunited, discontinuous); they are beset processed with digital computers. As a result of this, digital computers are mostly used in commercial and business places today.

##### **Analog Computer**

It measures rather than counts. This type of computer sets up a model of a system. Common type represents it variables in terms of electrical voltage and sets up circuit analog to the equation connecting the variables. The answer can be either by using a voltmeter to read the value of the variable required, or by feeding the voltage into a plotting device. They hold data in the form of physical variables rather than numerical quantities. In theory, analog computers give an exact answer because the answer has not

been approximated to the nearest digit. Whereas, when we try to obtain the answers using a digital voltmeter, we often find that the accuracy is less than that which could have been obtained from an analog computer.

It is almost never used in business systems. It is used by the scientist and engineer to solve systems of partial differential equations. It is also used in controlling and monitoring of systems in such areas as hydrodynamics and rocketry; in production.

There are two useful properties of this computer once it is programmed:

1. It is simple to change the value of a constant or coefficient and study the effect of such changes.
2. It is possible to link certain variables to a time pulse to study changes with time as a variable, and chart the result on an X-Y plotter.

### **Hybrid Computer**

In some cases, the user may wish to obtain the output from an analog computer as processed by a digital computer or vice versa. To achieve this, he set up a hybrid machine where the two are connected and the analog computer may be regarded as a peripheral of the digital computer. In such a situation, a hybrid system attempts to gain the advantage of both the digital and the analog elements in the same machine. This kind of machine is usually a special-purpose device which is built for a specific task. It needs a conversion element which accepts analog inputs, and output digital value. Such converters are called digitizers. There is need for a converter from analog to digital also. It has the advantage of giving real-time response on a continuous basis. Complex calculations can be dealt with by the digital elements, thereby requiring a large memory, and giving accurate results after programming. They are mainly used in aerospace and process control applications.

### **3.2 Classification By Purpose**

Depending on their flexibility in operation, computers are classified as either special purpose or general purpose.

#### **Special Purpose Computers**

A special purpose computer is one that is designed to solve a restricted class of problems. Such computers may even be designed and built to handle only one job. In such machines, the steps or operations that the computer follows may be built into the hardware. Most of the computers used for military purposes fall into this class. Other example of special purpose computers include:

- ❖ Computers designed specifically to solve navigational problems.
- ❖ Computers designed for tracking airplane or missiles.
- ❖ Computers used for process control applications in industries such as oil refinery, chemical manufacture, steel processing and power generation.
- ❖ Computers used as robots in factories like vehicles assembly plants and glass industries.

#### **General Attributes of Special Purpose Computers**

Special purpose computer are usually very efficient for the tasks for which they are specially designed.

They are very much less complex than the General-Purpose Computers. The simplicity of the circuiting stems from the fact that provision is made only for limited facilities.

They are very much cheaper than the General-Purpose type since they involve less components and are less complex.

#### **General-Purpose Computers**

General-Purpose computers are computers designed to handle wide range of problems.

Theoretically, a general-purpose computer can be adequate by means of some easily



alterable instructions to handle any problems that can be solved by computation. In practice however, there are limitations imposed by memory size, speed and the type of input/output devices. Examples of areas where the general purpose are employed include the following:

- Payroll
- Banking
- Billing
- Sales analysis
- Cost accounting
- Manufacturing scheduling
- Inventory control

#### General Attributes of General-Purpose Computers

- General-Purpose computers are more flexible than special purpose computers. They can handle a wide spectrum of problems.

They are less efficient than the special-purpose computers due to such problems as;

- Inadequate storage;
- Low operating speed;
- Coordination of the various tasks and subsection may take time.
- General Purpose Computers are more complex than the special purpose ones.

### **3.3 Classification of Computers According to Capacity**

In the past, the capacity of computers was measured in terms of physical size. Today, however, the physical size is not a good measure of capacity because the modern technology has made it possible to achieve compactness.

A better measure of capacity today is the volume of work that computer can handle. The volume of work that a given computer handles is closely tied to the cost and to the memory size of computer. Therefore, most authorities today accept the price of rental price as the standard for ranking computers.

Here, both memory size and cost shall be used to rank (classify) computer into three main categories as follows:

- (a) Microcomputers
- (b) Medium/Mini/Small Computers
- (c) Large Computer/Main Frames.

### **Micro Computers**

Microcomputers, also known as single board computers, are the cheapest class of computers. In the microcomputer, we do not have a Central Processing Unit (CPU) as we have in the larger computers rather we have a microprocessor chip as the main data processing unit. They are the cheapest smallest and can operate under normal office condition. Examples are IBM, APPLE, COMPAQ, Hewlett Packard (HP), Dell Toshiba, e.t.c.

### **Different Types of Personal Computers (Micro Computers)**

Normally, personal computers are placed on table desk hence they are referred to as desktop personal computers. Still other types are available under the categories of personal computers. They are:

**Laptop Computers** are small size types that are battery-operated. The screen is used to cover the system while the keyboard is installed flatly on the system unit. They could

be carried about like a box when closed after operation and can be operated in vehicles while on a journey.

### **Notebook Computer**

This is like laptop computers but smaller in size. Though small, it comprises all the components of a full system.

### **Palmtop Computer**

Palmtop computer is far smaller in size. All the components are complete as any of the above but made smaller so that it can be held on the palm.

### **Uses of Personal Computers**

Personal computers can perform the following functions:

- Can be used to produce documents like memos, reports, letters and briefs.
- Can be used to calculate budget and accounting tasks
- It can analyze numeric function
- It can create illustrations
- Can be used for electronic mails
- Can help in making schedule and plan projects.
- It can assist in schedules and plan projects.
- It can assist in searching for specific information from lists or from reports.

### **Advantages of Personal Computers**

- Computer is versatile; it can be used in any establishment.
- Has faster speed for processing data.
- Can deal with several data at a time
- Can attend to several users at the same time, thereby able to process several jobs at a time.

- Capable of storing several data.
- Operating of Computer is less fatigue
- Network possible, that is linking of two or more computers together.

### **Disadvantages of Personal Computers**

- Computer is costly to maintain.
- It is very fragile and complex to handle
- It requires special skill to operate
- With the invention and innovation everyday, computer suffers from being obsolete.
- It can lead to unemployment when used mostly in less Developed Countries.
- Some computers can not function properly without the aid of cooling system e.g. air-condition or fan in some locations.

### **Mini Computers**

The Mini Computers have memory capacity in the range 128K bytes to 256 Kbytes and are also not expensive but reliable and smaller in size compare to mainframe. It was first introduced in 1965; when DEC (Digital Equipment Corporation) built the PDP – 8. Other Mini Computer includes WANG VS.

### **Mainframe**

The Main Frame Computers often called number crunches have memory capacity of the order of 4 Kbytes and they are very expensive. They can execute up to 100MIPS (Meanwhile Instructions Per Second). They have large systems and are used by many people for a variety of purpose.

#### **4.0 Conclusion**

Computers are classified based on three major criteria namely size, type of signal being processed and purpose. The classification adopted at any point in time depends on the issues involved. For instance, if our goal is to process different kinds of signals or to accept one type of signal and convert to another form of signal, we should look in the realm of analog or digital or even the hybrid computers. This of course, calls for a converter such as Analog to Digital Converter or Digital to Analog Converter as the case may be.

#### **5.0 Summary**

In this unit we have been able to understand the following:

- i. Computers could be classified based on three major criteria: size, type of signal being processed and purpose.
- ii. Based on size computers are classified as mainframe, mini computer and microcomputer.
- iii. Based on the type of signal being processed, computers are classified as analog, digital and hybrid.
- iv. Based on purpose, computers are classified as general purpose or special purpose computers.
- v. Micro computers now come in different forms due to the continued reduction in size due to advances in electronic technology. Microcomputers could be desktop, laptop or palmtop.

## 6.0 Tutor Marked Assignment

- a) Classify computer based on type of signal.
- b) Based on signal being processed, what category does each of these computing equipment belong: petrol pump, thermometer, cellphone, anti-aircraft radar control in a military based, weather forecasting equipment at the metrological station.

## 7.0 References and Further Reading

Akinyokun, O.C, (1999). *Principles and Practice of Computing Technology*.

International Publishers Limited, Ibadan.

Balogun, V.F., Daramola, O.A., Obe, O.O., Ojokoh, B.A., and Oluwadare S.A., (2006).

*Introduction to Computing: A Practical Approach*. Tom-Ray Publications, Akure.

Larry Long (1984). *Introduction to Computers and Information Processing*. Prentice-Hall Inc., New Jersey.

Gray S. Popkin and Arthur H. Pike (1981). (1981). *Introduction to Data Processing with BASIC*, 2<sup>nd</sup> edition, Houghton Mifflin Company, Boston.

## **MODULE 2: COMPUTER HARDWARE**

In this module we shall discuss the following:

- Hardware components – (the front, back and inside of the system unit)
- The peripheral devices
- The Auxiliary equipment

### **STUDY UNIT 4: HARDWARE COMPONENTS (1)**

#### **Table of content**

Essential components of the computer

The system unit

The front of the system unit

Back of the system unit

Inside the system unit

- Central processing unit (CPU)
- Power supply unit
- Mother board
- Memory chips
- Types of memory

Primary memory

Read only memory (ROM)

Random access memory (RAM)

Secondary memory

Hard Disk

Tertiary memory

Floppy disk (diskette)

CDROM

## **1.0 Introduction**

Your Personal Computer (PC) is really a collection of separate items working together as a team-with you as the captain. Some of these components are essential; others simply make working more pleasant or efficient. Adding extra items expands the variety of tasks you can accomplish with your machine.

### **1.0 The Objectives**

The objectives of this unit are to:

- i. Familiarize the student with the components of the computer.
- ii. Enable the student to appreciate the importance of each of the components to the overall smooth operations of the computer.

## **3.0 The System Unit**

The system unit is the main unit of a PC. It is the Computer itself while other units attached to it are regarded as peripherals. It could be viewed as the master conductor orchestrating your PC's operation. It is made up of several components like the Motherboard, Processor, Buses, memory, power supply unit, etc. This unit (system unit) has been confused over the years by novices as the CPU. This is not true. The CPU (Central Processing Unit) or simply processor is a component within the system unit and it is not the only thing that makes up the system unit. Hence, it will be wrong to equate the system unit with the CPU.

### **3.1 Front of the System Unit**

#### **Lights**

Your unit may display a variety of colored light on the front panel, including power and turbo signals, and light to indicate if the Hard or Floppy disk are being read or written to.



**Key Lock**

You can stop intruders tampering with your PC by using the Lock on the front panel.

Turning the key prevents the key board from working.

**Turbo Button**

Some PCs offer a choice of speeds at which they can run. A turbo switch is usually left so the computer runs at its fastest speed.

**Reset Button**

If your PC “freezes” and won’t respond to any command, try starting it up again using the reset button. Pressing the reset button loses all the work you have not saved in that session, so use it only as a last resort.

**Power On/Off**

All PCs have main power switch on the system unit. Sometimes this control is placed on the outside back panel.

**Floppy Disk Drives**

Either, or both, of two standard types of floppy disk drive may be found at the front of the system unit. Some systems also have internal CD-ROM or tape drives.



CD-ROM or DVD drive

### **3.2 Back of the System Unit**

#### **Fan Housing**

The electronic components in your PC generate a lot of heat. To prevent overheating, a fan at the back of the unit removes hot air from the system.

#### **Power “in” and “out” Sockets**

Cables plugged into these sockets carry power from the electrical outlet to the system unit and from the system unit to the monitor.

#### **Joystick Port**

Using a joystick is often much better than pressing keys to control movements when playing a computer game.

#### **Serial Ports**

Serial Ports often connect the PC to modem or mouse. Most PCs are fitted with two serial ports that may be labeled “S101” and “S102”, “Serial 1” and “Serial 2”, or “COM 1” and “COM 2”.

### **Sound Jacks**

If you have a sound fitted inside your system unit, you will see a jack or jacks at the back. These can be used to connect your PC to speakers, a microphone, or an external sound source.

### **Keyboard Port**

The cable from your keyboards ends with a round connector, which plugs into the keyboard port.

### **Network Adapter**

If an expansion card is fitted to link your PC with other PCs in your office you will see a network connector at the back of the system unit.

### **Monitor Port**

A cable from your monitor plugs into this port and carries display information to the monitor.

### **Bays for Expansion Cards**

PCs are easily expanded-perhaps to provide a modem, sound or faster graphics. You can plug cards into expansion slots inside the PC. The end of an expansion card shows at the back of your machine, allowing you to connect items.

### **3.3 Inside the system unit**



The brain behind everything that happens in your PC is contained within the system unit. Inside the unit are the impressive electronics that run programs, handle instructions, and determine the results. Most of the more important items are described below:

### **Battery**

A small battery powers a clock to keep track of the time when the PC is turned off. It also maintains low electricity to certain RAM chips that record which components are installed.

### **Disk Drive Controller Card**

This card controls the PC's disk drive motors and transfers data. The serial and parallel ports at the back of the card link internal PC components with external devices such as mouse and printer.

### **Display Adapter Card (Video Card)**

All the information your computer will display is stored in its memory. To be useful, you need to see the information. The display adapter card is the link between the PC's memory and the monitor.

### **Expansion Slots**

These long narrow connectors allow you to plug in expansion cards (also known as adapter cards), which offer extra options not available on a basic PC.

### **ROM Chips**

Read-only memory (ROM) chips have data written on them during manufacturing that tells the CPU what to do when the PC is switched on. The data is always there, even when you switch the PC off.

## RAM Chips

When a computer is switched on and running a program, RAM (Random Access Memory) is used for purposes such as holding the program and its data. But when the PC is switched off, anything held in RAM is lost.

## Empty RAM Chip Slots

These slots let you expand your computer's memory by adding extra RAM chips or modules. Some PC's work even faster because they come equipped with Cache Memory. Cache Memory consists of expensive and very fast memory chips that store the data or instructions that the CPU will look at next. Cache memory can speed up work on your computer enormously.



RAM chip

## Central Processing Unit (CPU)



Intel Processor

The Microprocessor, or Central Processing Unit (CPU), is the computer's most important single item. It does all the PC's thinking and runs the programs (series of instructions) that you request.

### **CPU Support Chips**

These chips help the CPU manage all the other parts of the computer.

### **Math Coprocessor Slot**

A math coprocessor, present in some PCs, assists the CPU in its number-crunching activities (if programs have been designed to use it).



CPU fan

### **Speaker**

The speaker emits the computer's sound output.

### **Power Supply Unit**

All the components in a PC need electrical supply. Most need a 5-volt supply although the floppy disk drive motors required 12 volts. If the components were connected to

normal household current, they would blow up, so the power supply unit converts high voltage electrical current to a low voltage.

### **Hard Disk Drive**

The hard disk is your computer's main permanent storage unit, holding large amount of data and programs. Unlike data held in RAM, the information on the hard disk is not affected when the PC is turned off – it remains there unless you instruct the PC to overwrite it or the hard disk is damaged.



Hard drive (Hard disk)

### **Motherboard**

All the electronic components in a PC are mounted on a piece of fiberglass called the motherboard. Fiberglass cannot conduct electricity, so each component is insulated from all the others. Thin lines of metal on the surface of the fiberglass connect pins from one component to another, forming the computer's electrical circuits.

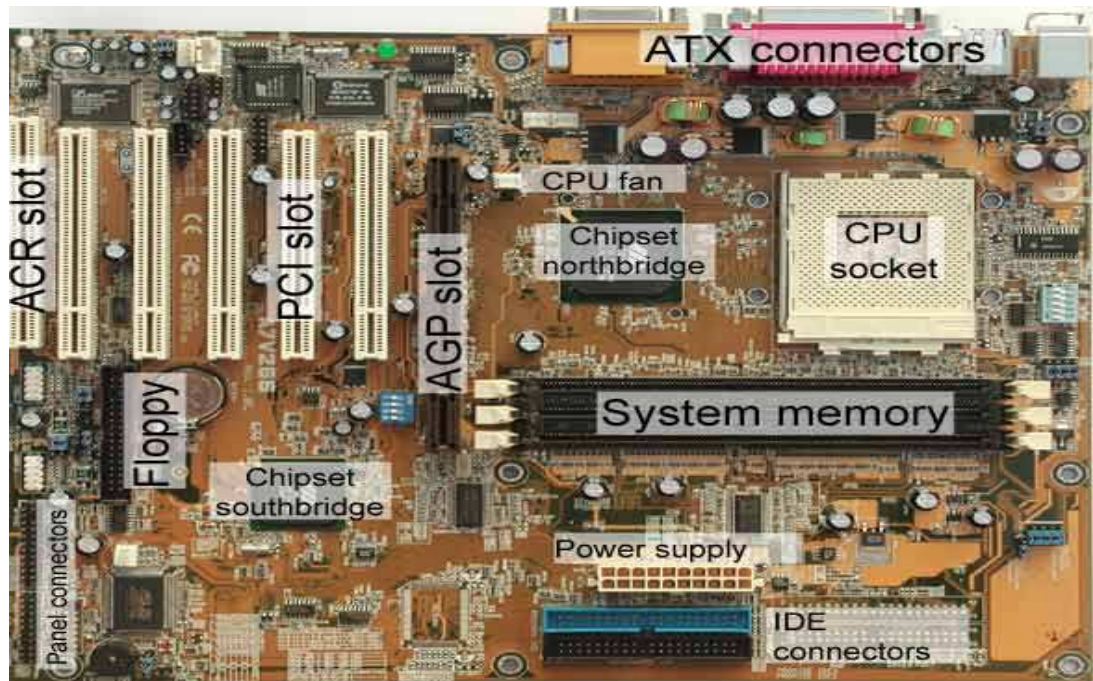

Components of a motherboard

### Intel CPUs

The earliest PCs were equipped with a CPU from Intel Corporation called the 8088. The next generation of PCs used CPU known by the number “80286 and were called “PC/AT” computers. Subsequently, PCs have been supplied with more and more powerful CPUs – the 80386, the 80486, and the more recent and impressive of all, the Intel Pentium (I, II, III, IV& M).

All these PC processors belong to a family called 80 x 86. In general, you can run the same software on PCs containing different CPUs within this family. From the outside, the chips look different only in sizes and number of pin-put inside, an 80486 has over one million components to the 3,500 that were in the first 8088. Because of these differences, the latest Pentiums runs over ten times faster.



## What is CPU

The CPU is certainly the most important PC component. CPU stands for *Central Processing Unit*. Let us briefly study that name:

- It is a processor, because it processes (moves and calculates) data.
- It is central, because it is the center of PC data processing.
- It is a unit, because it is a chip, which contains millions of transistors.

## CPU Speed

The speed of a CPU is measured in megahertz (MHz). A computer has central clock that keeps all the components in time with each other; one hertz is similar to a clock tick and megahertz is equal to one million ticks per second. If your PC runs at 333 or 400MHz, the central clock ticks 333 or 400 million times every second. As you might imagine, the faster the clock ticks, the faster the computer runs.

Without the CPU, there would be no PC. Like all other hardware components, the CPUs are continually undergoing further development. You can see the explosive technological development in data processing most clearly in the development of newer and faster CPUs. The CPUs have for years doubled their performance about every 18 months and there are no indications that this trend will stop.

When we now look at all the CPUs from a broader perspective, we can see that:

- The CPU history is closely tied to the companies IBM and especially *Intel*.

- The CPUs have their roots back to Intel's chip *4004* from 1971.
- The *compatibility* concept has been important throughout the development.

### Generations of CPUs

There are CPUs of many brand names (IBM, Texas, Cyrix, AMD), and often they make models which overlap two generations. This can make it difficult to keep track of CPUs. Here is an attempt to identify the various CPUs according to generation:

### History of CPU

The following table shows the different CPU *generations*.

PC	CPUs	Year	Number of transistors
1st. Generation	8086 and 8088	1978-81	29,000
2nd. Generation	80286	1984	134,000
3rd. Generation	80386DX and 80386SX	1987-88	275,000
4th. Generation	80486SX, 80486DX, 80486DX2 and 80486DX4	1990-92	1,200,000
5th. Generation	Pentium Cyrix 6X86 AMD K5 IDT WinChip C6	1993-95 1996 1996 1997	3,100,000 -- -- 3,500,000
Improved 5th. Generation	Pentium MMX IBM/Cyrix 6x86MX IDT WinChip2 3D	1997 1997 1998	4,500,000 6,000,000 6,000,000
6th. Generation	Pentium Pro AMD K6 Pentium II AMD K6-2	1995 1997 1997 1998	5,500,000 8,800,000 7,500,000 9,300,000
Improved 6th.	Mobile Pentium II	1999	27,400,000

Generation	Mobile Celeron Pentium III AMD K6-3 Pentium III CuMine		18,900,000 9,300,000 ? 28,000,000
7th. Generation	AMD original Athlon AMD Athlon Thunderbird Pentium 4	1999 2000 2001	22,000,000 37,000,000 42,000,000



Intel Processor

## DISKS

### Floppy Disks

Computers use disk to store information. Although there is a permanent hard disk that lives inside the system unit, you can use floppy disks to store and move data easily from one PC to another. Floppy disks come in two sizes, either 5¼ or 3½ inches in diameter. The smaller disks are able to store more data and are also less easily damaged, because of their thicker plastic cases. As both sizes can be either “high” or “low” capacity (or density), there are four main varieties of disks available. High-capacity disks are more expensive, but they can store much more information. Low-capacity disks are generally

labeled DS/DD, which stands for “double sided/double density”, while the high-capacity floppy disks are labeled DS/HD (double sided/high-density”).

### **Caring for Disks**

Treat floppy disks carefully, and you can take them almost anywhere safely. Don’t leave the disks in your PC when you finish a session. Also avoid putting anything heavy on top of your disks or leaving them in extremes of hot or cold temperature. Try not to carry disks loose in pockets or handbags where dust and dirt may get inside the containers. Take care to store them vertically, preferably in a special storage box. Remember too that you should keep floppy disks away from magnetic fields, including hidden magnets such as those in telephone, radio and television speakers, amplifiers, desk fans, and photocopiers. If you do leave floppy disks near magnetic field, your data may become corrupted and will no longer be usable.

### **Write Protecting Disks**

Write – protecting a disk means that you prevent the computer from erasing or writing over important data or programs that are already there. However, the PC can still read a write-protected disk.

## **4.0 Conclusion**

The system unit is a box housing many components. It is in fact, the most important part of the computer because it houses the processor (CPU) and other essential components that enables the computer to function.

## **5.0 Summary**

In unit we studied the components of the system unit which include the components in the front, the back and those that are inside the.

## 6.0 Tutor Marked Assignment

- a. Make a list of 5 components that could be found inside the computer systems unit.
- b. Describe the functions of each of them.
- c. Differentiate between CPU and the Systems unit.

## 7.0 References and Further Reading

Akinyokun, O.C, (1999). Principles and Practice of Computing Technology.

International Publishers Limited, Ibadan.

Balogun, V.F., Daramola, O.A., Obe, O.O., Ojokoh, B.A., and Oluwadare S.A., (2006).

Introduction to Computing: A Practical Approach. Tom-Ray Publications, Akure

Richard H. Austing and Lillian Cassel (1986). *Computers in Focus*. Books/Cole Publication Company. Monterey, California.

Larry Long (1984). *Introduction to Computers and Information Processing*. Prentice-Hall Inc., New Jersey.

## **STUDY UNIT 5**

### **HARDWARE COMPONENT (2) – PERIPHERAL DEVICES**

#### **Table of contents**

Input devices

Computer keyboard

Mouse and joystick

Digital or graphic tablet

Optical character reader (OCR)

Magnetic Ink Character Reader (MICR)

#### **1.0 Introduction**

The computer peripheral devices are those devices which are attached to the system unit.

The devices are necessary to ensure that the computer is able to accept input and display the result for the user. This section therefore discusses the input unit and the output unit.

#### **2.0 Objectives**

The objectives of this unit are to:

- i. Expose the students to those components that make up the input unit and the output unit.
- ii. Enable students get deeper understanding of the functions of the input and the output unit.
- iii. Guide the students on the type of input unit and output unit suitable to a particular computing environment.

#### **3.0 Input Devices**

##### **3.1 Computer Keyboard**

A Computer keyboard is identical to the conventional typewriter keyboard. However, it has more keys than the typewriter keyboard. A computer keyboard can be a dummy type or intelligent type. A computer keyboard is considered too be intelligent if, in addition to

performing the routine functions characteristic of a typewriter keyboard, it can initiate a series of actions for a computer to carry out by mere pressing a key or combination of two or more keys. An intelligent computer keyboard has a set of keys and when one of them is pressed, the computer can be made to carry out a specific function. For example, the pressing of a key may cause the computer to display a menu list from which a human being may be prompted to select one.

The intelligent computer keyboard has four major divisions, namely: Function keys, Alphanumeric keys, Numeric keys and Control keys.

In addition to the four types of keys, there are some special or important keys such as the following:

- (a) Return or Enter key
- (b) Escape key denoted by ESC
- (c) Control key denoted by CTRL
- (d) Alternate key denoted by ALT
- (e) Delete key denoted by DEL
- (f) Insert key denoted by INS
- (g) Backspace key
- (h) Shift key.

### **Function Keys**

The effects of the functions keys are software package dependent. That is, they mean different translations depending on which software package one is running on the computer. The function keys are traditionally labeled F1, F2, F3, F4, F5, F6, F7, F8, F9, F10, F11 and F12. The function keys are often arranged to the left of the main keyboard in two columns or they are arranged in a row above the main keyboard. In most software packages, the function key F1 is used to run the HELP program. Word perfect, for example, uses F3 for HELP program and F1 to cancel the last command issued on the computer. The function keys F7 and F12 are used to save a text and block a section of a text respectively in word perfect. Function keys can be programmed to carry out the functions desired by a programmer. For example the function keys F10 may be programmed to display menus. Thus, the operations of the function keys can be

determined by the user or programmed by the software package being used at any point in time.

### Alphanumeric Keys

The Alphanumeric keys can be likened with the conventional typewriter keys. They contain alphabetic characters, numeric characters and special characters such as comma, full stop, open bracket, close bracket, asterisk, semicolon, colon, question mark, and so on. Usually, each key carries a character at the lower part and another character at the upper part. The SHIFT key is used to switch on or off the lower and upper characters by the programmer.

### Cursor Control Keys

The cursor marks the active or current spot on the screen. It is an indicator that tells the user where in the midst of a document the system is pointing to. It may be a rectangular bar of light or a blinking underscore. When a text is being typed, the cursor moves as the carriage on a keyboard moves and character are typed in. The cursor control keys include four directional arrow keys.

CONTROL KEY	FUNCTIONS
↑	Moves the cursor one line up.
↓	Moves the cursor one line down
→	Moves the cursor one character to the right
←	Move the cursor one character to the left.
HOME	Moves the cursor to the beginning of a line or page
END	Move the cursor to the bottom left of a page or to the end of the current line in most text editors
PGDN	Moves the cursor to the top of the next page in the document or text. For example, pressing this key while on page 5 of the text will place the cursor at the top of the page 6 of the text.
PGUP	Moves the cursor to the top of the previous page. For example, if you are on page 3 of a document, pressing this key will place the cursor at the top of page 2 of the document

Other cursor control keys are HOME, PAGE UP, PAGE DOWN, and END. These keys may be part of the numeric keypad or separated from the numeric keypad. Moving the



cursor around on the screen is one of the most common tasks in an application program. In fact, cursor movement is so important in an application such as word processing that it can usually be accomplished by additional key-driven commands. The control keys and their functions are documented in Table the above table.

### **Numeric Keypad**

The numeric keypad contains a set of keys required for typing or entering number digits 0, 1, 2, 3, 4, 5, 6, 7, 8, and 9 into the computer store. A numeric key is often activated by pressing the Numlock Key. The numeric keypad is also used in combination with Alternate (Alt) key to produced extended characters. Extended characters are characters not normally found on most keyboard. For example, to produced the character alpha data denoted 'α', one holds down the Alt key and press 224; to produce character beta denoted by 'β', one holds down the Alt key and press 255 and to produce pound sterling denoted by '£', one holds down the Alt key and press 156.

### **Shift Key**

When the Shift key is pressed, the capital letters on the alphanumeric keys are activated. It also serves as the activator of characters that are at the upper part of each alphanumeric key. The Shift key has no effects on itself; its effect are realized when some other keys are pressed. Thus, if one presses the shift key and then 'equal' sign key, the 'plus' sign which is at the upper part of the 'equal' sign is activated and then it appears on the screen.

### **CapLock Key**

The CapLock Shifts all alphabetic characters into upper case (capital letters). Thus all characters typed are in lower case (small letters) when not pressed.

### **Alternate Key (Alt)**

The Alternate key can be used in combination with numeric keys to generate characters not shown on the keyboard, that is, extended characters. For example, holding the Alt key down and pressing 228 produces the summation ( $\Sigma$ ) sign; holding the Alt key down and pressing 235 produce  $\delta$  sign. To restart or reboot your computer, press Alt, Ctrl and Del keys simultaneously.

### **NumLock Key**

The Numlock key activates the numeric keypad. Neither NumLock nor CapLock affects the function keys.

### **Control Key (Ctrl)**

The Control key is often used in most text mode to perform block operations like mass deletion, insertion and so on. For example, CTRL + Y deletes a line in most text documents. It can also be used in combination with other keys to move the cursor to different locations in a text or document. In some application packages, the Alt, Ctrl and Shift key are used in combination with the function keys to perform several operations. For example, in Word Perfect word processing package, to centre a text; press Shift and F6; to print a text, press Shift and F7.

### **Escape Key (Esc)**

The Escape key cancels an operation in progress. For example, when one is editing a file or issuing a command, ESC cancels any changes one might have made or terminates the command.

### **Return or Enter Key**

The Return key serves as one of the most important keys on most keyboards. It is actually used to inform the computer the end of an input or command. It performs two functions depending on the program with which it is used. For example, suppose you are asked to respond to an operating system command at the prompt or other entries, the operating system will wait until the return key is pressed before continuing. Pressing the return key also positions the cursor at the beginning of the next line ( in text mode), which is the equivalent of pressing the carriage return on a typewriter.

### **Insert Key (Ins)**

Pressing the Insert key puts ones keyboard in insert mode, pressing it again returns to overstrike (typeover) mode. In insert mode, the characters one types are inserted at the cursor position, the character at the cursor position and all characters to the right, shift to make room for them. In overstrike or typeover mode, newly typed characters overwrite the characters at the current cursor position. In most application software insert mode is indicated by a symbol in the status line.

**Delete Key (Del)**

The delete key deletes the character at the cursor position when pressed and the remaining text moves to the left while the cursor remains at the same position.

**Back Space Key**

The Back Space Key deletes the characters to the left of the cursor when pressed and all other characters to the right of the cursor are shifted one space to the left.

**Spacebar**

The Spacebar is the longest key found on most keyboards. It erases characters at the cursor position or gives blank space when pressed.

**Tab Key**

The Tab Key moves the cursor by five spaces to the right when pressed. The number of positions moved depend on the software or the Tab Set by the operator. The Tab is normally pressed to insert paragraphs during typing. In some programs, when this key is pressed in combination with shift key, the same number of positions is moved backwards.

**Print Screen Key (Prtsc)**

When the Print Screen key is pressed in combination with the Shift Key, whatever in is the screen will be printed on a printer. The same effect can be achieved by pressing the key alone on some keyboards.

**Keeping Your Keyboard Clean and Working**

Never spill liquids on your keyboard. Coffee, soda, and other beverage spills can ruin your keyboard. Liquid spills on the keyboard have even been known to cause electrical damage to the PC itself. With that in mind, though you may not stop drinking coffee around your computer, you should at least get a spill-proof mug or keep the coffee on the other side of the desk.

Another enemy of keyboards is static electricity. Static electricity can have the same damaging effect on your keyboard as does liquid. If your keyboard doesn't respond properly after a strong static charge, you may just need to turn off the PC and turn it back on to reset the keyboard. In some cases, however, the static discharge can zap the keyboard and even parts of the PC. If you shuffle your feet across carpet or your PC is in a room with dry air, avoid touching the PC or the keyboard until you have touched something metal to discharge any static. If you don't have a metal desk or bookcase in your work area, consider buying an anti-static mat and keeping it where you can touch it before touching the PC.

Dust, dirt, food crumbs, and hair are other enemies of keyboards. Try to avoid eating over the keyboard and if your computer is in a dirty, dusty area, keep the keyboard covered when not in use.

Some dirt and dust is unavoidable. To keep the keyboard working well, you should occasionally clean it.

### **3.2 Mouse and Joystick**

A mouse looks like the electrical clipper in a barbing saloon. It consists of a pointing device very sensitive to movements. It has a roller ball and two or more buttons which can be pressed to make selection. By moving the mouse on a flat smooth surface and clicking one or combination of two buttons on its upper surface, a computer to which it is connected can be sensitized and commanded to carry out some specific tasks.

A mouse can be used to draw diagrams on computer screen more effectively and efficiently than the computer keyboard. Generally, the keyboard and the mouse do complement each other. For example, the mouse can be used to highlight an item in a menu list while the keyboard Enter Key can be pressed to activate or evoke the command associated with the highlighted item.

A mouse is the primary input device for modern computers that feature operating systems with a graphical user interface, such as Windows 98 or Windows XP. While keyboards obviously excel at entering text, numbers, and symbols, your mouse is the tool you'll use to tell your computer what to do with all the data you've entered.

Joysticks are almost exclusively used with game software and help the user more effectively control the actions of computer-simulated airplanes or arcade-style games.

All modern PC operating systems (Windows 98, Windows XP, and the Macintosh) rely on an on-screen pointer to select and execute commands. A mouse is simply an input device built to help the user control this on-screen pointer in as natural and efficient a manner as possible.

The pointer on the screen mimics the movements of your mouse. As you move your mouse, a ball encased in the bottom of your mouse rolls on the desk and in turn sends signals to the computer as to which direction to move the pointer on the screen. Move the mouse side to side, or up and down, and the on-screen pointer moves in a similar manner.

Once you have the mouse positioned to select the command or data you want to act on, you use the mouse buttons to execute the command. *The mouse controls the on-screen pointer and lets you select program icons, manipulate property sheets, and access data.*

### 3.3 Output Device

#### 3.3.1 Printers

A printer is the computer component that lets you create copies of the information stored in your computer on paper. The printed material is often called hard copy, to differentiate it from the data stored on a disk, or held in the computer's memory.

There are three basic types of printers available for use with personal computers:

**Laser printers.** These combine a magnetic roller with powdered ink called toner to transfer high-quality characters or images onto a page.

**Inkjet printers.** These have small nozzles that actually spray fast-drying ink onto the page to form characters or images. Inkjet printers spray a fine, quick-drying ink through small nozzles to produce characters and images on paper. Although the results are not quite as sharp as those of laser printers, inkjet printers provide very good quality output at a lower cost.*Dot-matrix printers.*

These use a print head to strike an inked ribbon against paper, like a typewriter, creating characters out of a series of dots. Dot-matrix printers are the cheapest printers available. They create text and images on the page by hammering several small pins against an inked ribbon. The more pins used, the better the image--9-pin and 24-pin are common options. The 24-pin printers produce a better quality output, but are somewhat slower than the 9-pin printers.

Print quality for dot-matrix printers is often described in terms of mode: draft mode (low resolution), near-letter-quality mode (medium resolution), or letter-quality mode (high resolution). The speed depends on the mode, with draft mode being the fastest.

The type of printer you choose depends on your budget and the type of output you need. For example, if all you need to print are grocery lists, you may be happy with a dot-matrix printer. In general, dot-matrix printers are noisier, slower, and produce a poorer-quality image than do laser or inkjet printers, but they are also less expensive. If you need to print newsletters, brochures, or illustrated reports, you will probably want a high-quality laser printer. Laser printers cost more than other printers, but they may be worth the price because they are fast, quiet, and produce high-quality text and graphics.

### **3.3.2 Monitors**

. The monitor does not do any processing itself. The monitor only displays the information that the video card tells it to.

#### **Monitor Sizes**

The two most common monitor sizes are 15-inch and 17-inch. If you have an older, hand-me-down PC or a very inexpensive starter PC, you may have a smaller 14-inch monitor. 21-inch monitors are also available but mostly used by graphics professionals.

#### **VGA and SVGA Monitors**

The two most common acronyms you will see on current monitors are VGA or SVGA. Both of these terms generally refer to how many dots (or pixels) in each direction the monitor can display. VGA is 640x480 (width by height) and SVGA is 800x600. This measurement is called the monitor's *resolution*, and more is better! Most new monitors are capable of displaying at least SVGA quality. In fact, 1,024x768 is somewhat of a minimum to look for.

Almost any VGA or SGVA monitor made in the last few years is capable of displaying any of these resolutions. However, it's actually the video card that determines what resolution your monitor displays at any time. The monitor is capable of switching from one resolution to another on command from the video card.

### **3.3.3 Scanners**

Scanners are peripheral devices used to *digitize* (convert to electronic format) artwork, photographs, text, or other items from hard copy. In a sense, a scanner works as a pair of eyes for your PC. Your eyes see an image and translate the image into electrical impulses that travel to and are interpreted by your brain. Similarly, a scanner captures images and converts them to digital data that travel to and are interpreted by the computer.

A scanner works by dividing an image into microscopic rows and columns and measuring, like the film in a camera, how much light (or lack thereof) reflects from each individual intersection of the rows and columns. Each reflection is recorded as a dot, or picture element (pixel). After the scanner collects information from each dot, it compiles the result into a digital file on the computer.

There are a wide variety of scanners that work in a number of different ways, but the technology behind them is essentially the same. The following sections discuss the more popular types of scanners available today.

#### **Types of scanners**

##### **Flatbed Scanners**

Flatbed scanners look and behave a lot like a photocopier. You lay the item to be scanned on a glass plate and the scanning head passes below the glass.



Flatbed scanners are very versatile: you can scan objects in a variety of sizes and shapes, including pages from a book, without damaging the original. While flatbed scanners are the best choice for a wide variety of uses, if you plan to do a lot of text scanning (called *OCR* for *Optical Character Recognition*) work, keep in mind that flatbeds only accommodate one page at a time. Scanning multi-page documents can be a slow, tedious process, because you have to manually remove one page and insert the next.

### **Sheetfed Scanners**

Sheetfed scanners look and act more like fax machines. The page or item is fed into the machine, scanned, then spit out on the other end. A sheetfed scanner is a good choice for large volumes of text, but not for handling delicate original photographs. Scanning directly from a book or other three-dimensional object is impossible.

### **Hand Scanners**

Hand scanners are a low-cost alternative to their larger, more sophisticated counterparts. As their name implies, hand scanners are manual devices you move over a flat surface, just as you do your PC's mouse

The hand scanner's advantages are many, but so are its disadvantages. Generally, hand scanners work best for small, uncomplicated images such as company logos or small black-and-white photographs. You might want a hand scanner if you do not plan to use it on a regular basis, because it usually does not require adding internal cards to your CPU, and it's easily disconnected and stored away. Most hand scanners can only scan a four-inch wide image at one time and require a steady hand. You're usually provided with software that helps you "sew up" a series of these 4-inch, side-by-side scans into one image, but this is obviously not as convenient as getting the full image at once.

### **3.3.4 Speakers and Sound**

The built-in speakers in most PC cases are used just for making system sounds, such as warning beeps and action indicators. To play more sophisticated sounds on your PC, you need a set of external speakers. Usually speakers come in pairs, and there is a plug that connects them to your sound card. Arrange the speakers with one on the left and one on the right of your desk or work area to get a stereo effect.

Optionally, some speakers come with a *subwoofer*. This improves the bass (low notes) sound. If you have a subwoofer with your speakers, it should go on the floor under your desk.

Sound is one of the favorite options on today's PCs. In fact, sound is a standard feature of most new PCs.

Everyone has their own uses for sound. You may just want to play a few music CDs with your CD-ROM drive while you are working, or you may use multimedia applications for presentations or educational programs. You may just like the sound of your jet engines roaring as you punch the throttle in a flight simulator.

#### **Components for Sound on Your PC**

To produce sound on your PC, you need a sound card and speakers. The *sound card* is an expansion card that plugs into one of the slots on your motherboard. This card processes all of the instructions that have to do with sound, and then sends the sounds to the speakers to be played. The speakers plug into the sound card and

#### **Sound Cards**

Sound cards plug into an expansion slot in your PC. The card has a set of connectors that are exposed on the back of the PC; you can plug a microphone and speakers into the

connectors. Some cards include an optional connector for a *line input*, which is used to connect another input source such as the output from a tape player or portable CD player. Other optional connectors can include a joystick connector and a MIDI connector (for connecting a MIDI keyboard). The card may include a volume control, which controls the volume of the speakers and/or headphones.

#### **4.0 Conclusion**

The system unit cannot function without the peripheral devices. The input and the output units are very important peripheral devices that must be taken care of in setting up a computer system.

#### **5.0 Summary**

In this unit we have learnt the following:

- i. Input unit which comprises
  - (a) the keyboard – ( the different categories of keys on the keyboard and their functions).
  - (b) the scanner – different types of scanners
- ii. The output unit which is made up of the
  - (a) monitor,
  - (b) the printer and,
  - (c) the speakers.

#### **6.0 Tutor Marked Assignment**

- a. Justify the need for the input and the output units in a computer system.
- b. Describe the functions of the following keys: the numeric keys, control keys, shift keys and the function keys.

- c. In what situation will you recommend the laserjet printer and the dot matrix printer.

## **7.0 References and Further Reading**

Akinyokun, O.C, (1999). *Principles and Practice of Computing Technology*.

International Publishers Limited, Ibadan.

Balogun, V.F., Daramola, O.A., Obe, O.O., Ojokoh, B.A., and Oluwadare S.A., (2006).

*Introduction to Computing: A Practical Approach*. Tom-Ray Publications, Akure.

Francis Scheid (1983). *Schaum's Outline Series: Introduction to Computer Science*, McGraw-Hill Book Company, Singapore.

Richard H. Austing and Lillian Cassel (1986). *Computers in Focus*. Books/Cole Publication Company. Monterey, California.

Larry Long (1984). *Introduction to Computers and Information Processing*. Prentice-Hall Inc., New Jersey.

Gray S. Popkin and Arthur H. Pike (1981). (1981). *Introduction to Data Processing with BASIC*, 2<sup>nd</sup> edition, Houghton Mifflin Company, Boston.

## **STUDY UNIT 6: AUXILLARY EQUIPMENT**

### **Table of content**

Air conditioner

Voltage stabilizer

Uninterruptible Power Supply System (UPS)

### **1.0 Introduction**

The auxiliary equipment as their name suggests are not computers but are necessary in a computing environment in order to ensure proper functioning and smooth running of computing activities. In this module, we shall address in some details the importance of equipment such as air conditioner, voltage stabilizer, uninterruptible power system and line transformer in a data processing environment.

### **2.0 Objectives.**

The objectives of this unit are to:

- i. Identify the auxiliary equipment in a computing environment.
- ii. Discuss the importance of the auxiliary equipment to the smooth running of a computing centre.

### **3.1 Air Conditioner**

A Computer is an electronic machine. It is, therefore, capable of generating heat. A computer is manufactured to operate in an environment with a specific temperature range. When the temperature of the environment in which a computer is kept falls outside the specific range, the computer may function badly and consequently get damaged.

The free air is basically, dust laden. Dust is metallic in nature and, as such, capable of conducting electricity. If dust is allowed to settle on a computer, particularly the electronic circuits, the dust can bridge two circuits. The bridging of two electronic circuits may cause a serious damage to the computer. Thus, air conditioners are needed in a computer environment to:

- a. Condition the temperature
- b. Prevent dust.

### **3.2 Voltage Stabilizer**

A computer when switched on, takes off at a cold state, warms up and gradually gets to a hot state. At a hot state, a computer is always roaming in an attempt to find something to do. In a situation where the public electricity such as that of PHCN in Nigeria is cut suddenly, the computer would suddenly be brought to a halt. The sudden power cut may cause the computer to lose the memory of some basic house keeping operations when power eventually returns and the computer is switched on. The sudden power cut may also cause irreparable damages to the file the computer was processing at the time the power was suddenly cut.

### **3.3 Line Voltage Transformer**

We note that computers are built to operate within a specific range of voltages. In the United State of America, computers are built to operate on 110V. A voltage transformer is a device meant to step up or step down a voltage as the case may be. In Nigeria, for example, a 110V computer requires a voltage transformer to step down the 240V to 110V. Similarly, in USA, a 240V current is connected directly to a 110V computer, the computer power unit will blow up almost immediately.

Today, the technology has improved tremendously such that if a 240V current is connected directly to a 110V computer, only a fuse, rather than the power unit will blow up. It is worth mentioning, too, that there is an advanced technology today which permits a computer to operate effectively and efficiently with the power line voltage ranging between 110V and 240V. The technology supports an inbuilt switch which can be operated at two terminals namely: the 110V terminus and 240V terminus. In recent times, the technology has been improved upon such that computers are manufactured in such a way that they can sense the voltage that is adequate. Thus, if one connects a 110V computer to a 240V current, the 110V computer has an in-built line transformer which automatically steps down the 240V current to 110V.

### **3.4 Uninterruptible Power Supply System (UPS)**

An Un-interruptible Power System (UPS) is an auxiliary hardware that is capable of:

- (a) Converting the public electricity raw line into fine line, that is, conditioning the voltage that is fed into the computer.
- (b) Storing electrical energy when the public electricity line is life
- (c) Releasing the stored electrical energy to the computer when the public electricity line is dead.

### **4.0 Conclusion**

The computer is an expensive resource and as such requires adequate protection from electrical damage. Similarly, the UPS is an expensive resource; hence there is the need for it to be protected from electrical damage, too. Therefore, in practice, it is desirable that the UPS be protected by a voltage stabilizer which is rugged and less expensive. The configuration presented in Figure is an example of a computer environment characterized by the multiple levels of protection from electrical damage. This arrangement is desirable in a situation of electrical surge and blown out.

## **5.0 Summary**

In this unit we have learn the following:

- i. Auxiliary devices create a facilitative and conducive environment for smooth operation of computers and the user.
- ii. Voltage stabilizers help to protect computing equipment from damage due to power surge.
- iii. UPS protects the computing equipment and the software from power outage during computing session. The UPS with the help of its internal battery stores electrical energy while power is on and releases power stored to the computer whenever power is off. This enables the user to end the working session and shut down normally.
- iv. A voltage transformer is a device meant to step up or step down a voltage as the case may be.

## **6.0 Tutor Marked Assignment**

With the aid of annotated diagram, describe the arrangement of the following auxiliary equipment: UPS, line voltage transformer and voltage stabilizer in relation to PHCN power source and the computer.

## **7.0 References**

Akinyokun, O.C, (1999). Principles and Practice of Computing Technology.

International Publishers Limited, Ibadan.

Balogun, V.F., Daramola, O.A., Obe, O.O., Ojokoh, B.A., and Oluwadare S.A., (2006).

Introduction to Computing: A Practical Approach. Tom-Ray Publications,  
Akure.



## **MODULE 3: COMPUTER SOFTWARE**

In this module we shall discuss computer software under these headings:

- System software
- Language translators
- Utility software
- Application software

### **Study Unit 7: COMPUTER SOFTWARE (1)**

#### **Table of content**

System software

- Operating System
- Types of operating System

Language translators

Assemblers

Interpreters

Compilers

Utility software

#### **1.0 Introduction**

The computer hardware are driven by the software. The usefulness of the computer depends on the programs that are written to manipulate it. Computer software come in different forms: the operating system, utility software, language translators and application software. This unit therefore presents detailed discussions of each category of computer software.

## **2.0 Objectives**

The objective of this unit are to:

- i. Identify the different types of computer software.
- ii. Discuss the importance of each type of software.

## **3.0 Computer Software**

The physical components of the computer are called the hardware while all the other resources or parts of the computer that are not hardware, are referred to as the Software.

Software are the set of programs that makes the computer system active. In essence, the software are the programs that run on the computer.

Then, what is a program? A Program is a series of coded instructions showing the logical steps the computer follows to solve a given problem.

### **3.1 Classification of Computer Software**

The computer software could be divided into two major groups namely System Software (Programs) and Application Software (Programs).

#### **3.1.1 System Software**

This is refers to the suits of programs that facilitates the optimal use of the hardware systems and/or provide a suitable environment for the writing, editing, debugging, testing and running of User Programs. Usually, every computer system comes with collection of these suits of programs which are provided by the Hardware Manufacturer.

### **3.1.1.2 Operating System**

An operating system is a program that acts as an interface between a user of a computer and the computer hardware. The purpose of an operating system is to provide an environment in which a user may execute programs.

The operating system is the first component of the systems programs that interests us here. Systems programs are programs written for direct execution on computer hardware in order to make the power of the computer fully and efficiently accessible to applications programmers and other computer users. Systems programming is different from application programming because it requires an intimate knowledge of the computer hardware as well as the end users' needs. Moreover, systems programs are often large and more complex than application programs, although that is not always the case. Since systems programs provide the foundation upon which application programs are built, it is most important that systems programs are reliable, efficient and correct.

In a computer system the hardware provides the basic computing resources. The applications programs define the way in which these resources are used to solve the computing problems of the users. The operating system controls and coordinates the use of the hardware among the various systems programs and application programs for the various users.

The basic resources of a computer system are provided by its hardware, software and data. The operating system provides the means for the proper use of these resources in the operation of the computer system. It simply provides an environment within which other programs can do useful work.

We can view an operating system as a resource allocator. A computer system has many resources ( hardware and software) that may be required to solve a problem: CPU time, memory space, file storage space, input/output devices etc.

The operating system acts as the manager of these resources and allocates them to specific programs and users as necessary for their tasks. Since there may be many, possibly conflicting, requests for resources, the operating system must decide which requests are allocated resources to operate the computer system fairly and efficiently. An operating system is a control program. This program controls the execution of user programs to prevent errors and improper use of the computer.

Operating systems exist because they are a reasonable way to solve the problem of creating a usable computing system. The fundamental goal of a computer system is to execute user programs and solve user problems.

The primary goal of an operating system is a convenience for the user. Operating systems exist because they are supposed to make it easier to compute with an operating system than without an operating system. This is particularly clear when you look at operating system for small personal computers.

A secondary goal is the efficient operation of an computer system. This goal is particularly important for large, shared multi-user systems. Operating systems can solve this goal. It is known that sometimes these two goals, convenience and efficiency, are contradictory.

While there is no universally agreed upon definition of the concept of an operating system, we offer the following as a reasonable starting point:

A computer's operating system ( OS ) is a group of programs designed to serve two basic purposes:

1. To control the allocation and use of the computing system's resources among the various users and tasks, and.
2. To provide an interface between the computer hardware and the programmer that simplifies and makes feasible the creation, coding, debugging, and maintenance of application programs.

Specifically, we can imagine that an effective operating system should accomplish all of the following:

- Facilitate creation and modification of program and data files through an editor program,
- Provide access to compilers to translate programs from high-level languages to machine language,
- Provide a loader program to move the compiled program code to the computer's memory for execution,
- Provide routines that handle the intricate details of I/O programming,
- Assure that when there are several active processes in the computer, each will get fair and noninterfering access to the central processing unit for execution,
- Take care of storage and device allocation,
- Provide for long term storage of user information in the form of files, and
- Permit system resources to be shared among users when appropriate, and be protected from unauthorized or mischievous intervention as necessary.

Though systems programs such as editor and translators and the various utility programs (such as sort and file transfer program) are not usually considered part of the operating system, the operating system is responsible for providing access to these system resources.

### **Types of operating system**

Modern computer operating systems may be classified into three groups, which are distinguished by the nature of interaction that takes place between the computer user and his or her program during its processing. The three groups are called batch, time-shared and real time operating systems.

#### **Batch processing operating system**

In a batch processing operating system environment users submit jobs to a central place where these jobs are collected into a batch, and subsequently placed on an input queue at the computer where they will be run. In this case, the user has no interaction with the job during its processing, and the computer's response time is the turnaround time-the time from submission of the job until execution is complete, and the results are ready for return to the person who submitted the job.

#### **Time sharing operating system**

Another mode for delivering computing services is provided by time sharing operating systems. In this environment a computer provides computing services to several or many users concurrently on-line. Here, the various users are sharing the central processor, the memory, and other resources of the computer system in a manner facilitated, controlled, and monitored by the operating system. The user, in this environment, has nearly full

interaction with the program during its execution, and the computer's response time may be expected to be no more than a few second.

### **Real time operating system**

The third class of operating systems, real time operating systems, are designed to service those applications where response time is of the essence in order to prevent error, misrepresentation or even disaster. Examples of real time operating systems are those which handle airlines reservations, machine tool control, and monitoring of a nuclear power station. The systems, in this case, are designed to be interrupted by external signal that require the immediate attention of the computer system.

In fact, many computer operating systems are hybrids, providing for more than one of these types of computing service simultaneously. It is especially common to have a background batch system running in conjunction with one of the other two on the same computer.

A number of other definitions are important to gaining an understanding of operating systems:

### **Multiprogramming operating system**

A multiprogramming operating system is a system that allows more than one active user program (or part of user program) to be stored in main memory simultaneously.

Thus, it is evident that a time-sharing system is a multiprogramming system, but note that a multiprogramming system is not necessarily a time-sharing system. A batch or real time operating system could, and indeed usually does, have more than one active user

program simultaneously in main storage. Another important, and all too similar, term is 'multiprocessing'.

A multiprocessing system is a computer hardware configuration that includes more than one independent processing unit. The term multiprocessing is generally used to refer to large computer hardware complexes found in major scientific or commercial applications.

A networked computing system is a collection of physical interconnected computers. The operating system of each of the interconnected computers must contain, in addition to its own stand-alone functionality, provisions for handling communication and transfer of program and data among the other computers with which it is connected.

A distributed computing system consists of a number of computers that are connected and managed so that they automatically share the job processing load among the constituent computers, or separate the job load as appropriate particularly configured processors. Such a system requires an operating system which, in addition to the typical stand-alone functionality, provides coordination of the operations and information flow among the component computers.

The networked and distributed computing environments and their respective operating systems are designed with more complex functional capabilities. In a network operating system the users are aware of the existence of multiple computers, and can log in to remote machines and copy files from one machine to another. Each machine runs its own local operating system and has its own user (or users).



### **Distributed operating system**

A distributed operating system, in contrast, is one that appears to its users as a traditional uniprocessor system, even though it is actually composed of multiple processors. In a true distributed system, users should not be aware of where their programs are being run or where their files are located; that should all be handled automatically and efficiently by the operating system.

### **Network operating systems**

Network operating systems are not fundamentally different from single processor operating systems. They obviously need a network interface controller and some low-level software to drive it, as well as programs to achieve remote login and remote files access, but these additions do not change the essential structure of the operating systems.

True distributed operating systems require more than just adding a little code to a uniprocessor operating system, because distributed and centralized systems differ in critical ways. Distributed systems, for example, often allow program to run on several processors at the same time, thus requiring more complex processor scheduling algorithms in order to optimize the amount of parallelism achieved.

### **Operating system components**

An operating system provides the environment within which programs are executed. To construct such an environment, the system is partitioned into small modules with a well-defined interface. The design of a new operating system is a major task. It is very important that the goals of the system be will defined before the design begins. The type of system desired is the foundation for choices between various algorithms and strategies that will be necessary.

A system as large and complex as an operating system can only be created by partitioning it into smaller pieces. Each of these pieces should be a well defined portion of the system with carefully defined inputs, outputs, and function. Obviously, not all systems have the same structure. However, many modern operating systems share the system components outlined below.

### **Process Management**

A process is the unit of work in a system. Such a system consists of a collection of processes, some of which are operating system processes, those that execute system code, and the rest being user processes, those that execute user code. All of those processes can potentially execute concurrently.

The operating system is responsible for the following activities in connection with processes managed.

- The creation and deletion of both user and system processes
- The suspension and resumption of processes.
- The provision of mechanisms for process synchronization
- The provision of mechanisms for deadlock handling.

### **Memory Management**

Memory is central to the operation of a modern computer system. Memory is a large array of words or bytes, each with its own address. Interaction is achieved through a sequence of reads or writes of specific memory address. The CPU fetches from and stores in memory.

In order for a program to be executed it must be mapped to absolute addresses and loaded in to memory. As the program executes, it accesses program instructions and data

from memory by generating these absolute is declared available, and the next program may be loaded and executed.

The operating system is responsible for the following activities in connection with memory management.

- Keep track of which parts of memory are currently being used and by whom.
- Decide which processes are to be loaded into memory when memory space becomes available.
- Allocate and deallocate memory space as needed.

### **Secondary Storage Management**

The main purpose of a computer system is to execute programs. These programs, together with the data they access, must be in main memory during execution. Since the main memory is too small to permanently accommodate all data and program, the computer system must provide secondary storage to backup main memory. Most modern computer systems use disks as the primary on-line storage of information, of both programs and data. Most programs, like compilers, assemblers, sort routines, editors, formatters, and so on, are stored on the disk until loaded into memory, and then use the disk as both the source and destination of their processing. Hence the proper management of disk storage is of central importance to a computer system.

The operating system is responsible for the following activities in connection with disk management

- Free space management
- Storage allocation

- Disk scheduling.

### **I/O System**

One of the purposes of an operating system is to hide the peculiarities of specific hardware devices from the user. For example, in Unix, the peculiarities of I/O devices are hidden from the bulk of the operating system itself by the I/O system. The I/O system consists of:

- A buffer caching system
- A general device driver code
- Drivers for specific hardware devices.

Only the device driver knows the peculiarities of a specific device.

### **File Management**

File management is one of the most visible services of an operating system. Computers can store information in several different physical forms; magnetic tape, disk, and drum are the most common forms. Each of these devices has its own characteristics and physical organization.

For convenient use of the computer system, the operating system provides a uniform logical view of information storage. The operating system abstracts from the physical properties of its storage devices to define a logical storage unit, the file. Files are mapped, by the operating system, onto physical devices.

A file is a collection of related information defined by its creator. Commonly, files represent programs (both source and object forms) and data. Data files may be numeric, alphabetic or alphanumeric. Files may be free-form, such as text files, or may be rigidly

formatted. In general a files is a sequence of bits, bytes, lines or records whose meaning is defined by its creator and user. It is a very general concept.

The operating system is responsible for the following activities in connection with file management:

- The creation and deletion of files
- The creation and deletion of directory
- The support of primitives for manipulating files and directories
- The mapping of files onto disk storage.
- Backup of files on stable (non volatile) storage.

### **Protection System**

The various processes in an operating system must be protected from each other's activities. For that purpose, various mechanisms which can be used to ensure that the files, memory segment, cpu and other resources can be operated on only by those processes that have gained proper authorization from the operating system.

For example, memory addressing hardware ensure that a process can only execute within its own address space. The timer ensure that no process can gain control of the CPU without relinquishing it. Finally, no process is allowed to do it's own I/O, to protect the integrity of the various peripheral devices.

Protection refers to a mechanism for controlling the access of programs, processes, or users to the resources defined by a computer controls to be imposed, together with some means of enforcement.

Protection can improve reliability by detecting latent errors at the interfaces between component subsystems. Early detection of interface errors can often prevent contamination of a healthy subsystem by a subsystem that is malfunctioning. An unprotected resource cannot defend against use (or misuse) by an unauthorized or incompetent user.

### **Networking**

A distributed system is a collection of processors that do not share memory or a clock. Instead, each processor has its own local memory, and the processors communicate with each other through various communication lines, such as high speed buses or telephone lines. Distributed systems vary in size and function. They may involve microprocessors, workstations, minicomputers, and large general purpose computer systems.

The processors in the system are connected through a communication network, which can be configured in the number of different ways. The network may be fully or partially connected. The communication network design must consider routing and connection strategies, and the problems of connection and security.

A distributed system provides the user with access to the various resources the system maintains. Access to a shared resource allows computation speed-up, data availability, and reliability.

### **Command Interpreter System**

One of the most important component of an operating system is its command interpreter. The command interpreter is the primary interface between the user and the rest of the system.

Many commands are given to the operating system by control statements. When a new job is started in a batch system or when a user logs-in to a time-shared system, a program which reads and interprets control statements is automatically executed. This program is variously called (1) the control card interpreter, (2) the command line interpreter, (3) the shell (in Unix), and so on. Its function is quite simple: get the next command statement, and execute it.

The command statement themselves deal with process management, I/O handling, secondary storage management, main memory management, file system access, protection, and networking.

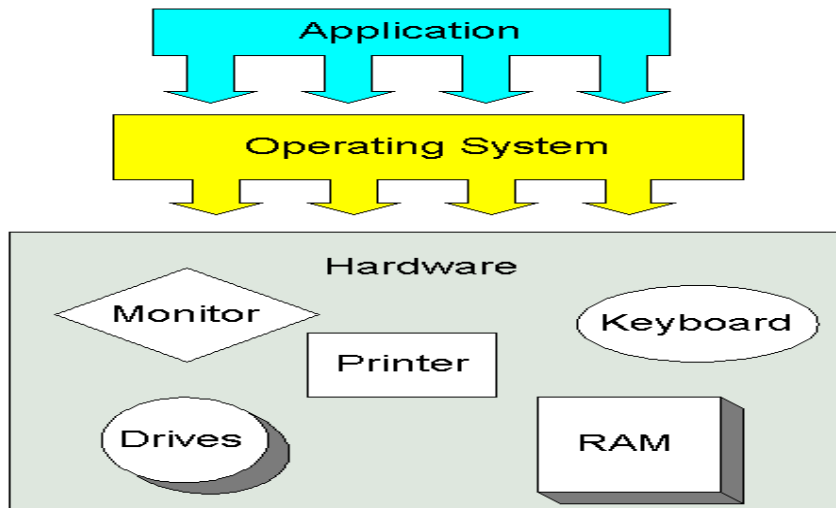

Fig. 1: Relationship between operating system and other components of the computer system.

#### 4.0 Conclusion

Operating system occupies a central place in computer operations. It manages the hardware, other software, the computer peripherals and the user. Operating systems have also evolved in line with the evolutionary trends in computer. This led to a variety of

types of operating systems. This and other issues relating to operating system are discussed in this unit.

## **5.0 Summary**

In this unit we have learnt the following:

- i. The operating system is the executive manager of the computer.
- ii. Types of operating system.
- iii. Functions of operating system.

## **6.0 Tutor Marked Assignment**

- a) Discuss the role of operating system in a computing environment.
- b) Differentiate between multi-user operating system and network operating system.
- c) What is the function of command interpreter in an operating system.

## **7.0 References and Further Reading**

Akinyokun, O.C, (1999). *Principles and Practice of Computing Technology*.

International Publishers Limited, Ibadan.

Balogun, V.F., Daramola, O.A., Obe, O.O., Ojokoh, B.A., and Oluwadare S.A., (2006).

*Introduction to Computing: A Practical Approach*. Tom-Ray Publications, Akure.

Silberschatz, A., Galvin, P., and Gagne, G. (2000). *Applied Operating System Concepts*, First Edition. John Wiley and Sons Inc., New York, USA.

Harvey Katzan, Jr. (1986). *Operating System: A Pragmatic Approach*, 2<sup>nd</sup> Edition. CBS Publishers and Distributors, New Delhi, India.



## **STUDY UNIT 8: COMPUTER SOFTWARE (2)**

### **Table of Content**

Language translator

Utility programs

Application programs

### **1.0 Introduction**

In unit 7, we discussed in full details, the operating system as the executive manager of the computer, its peripheral devices and the users. In this unit, we shall look at other types of software such as the utility programs and the application programs.

### **2.0 Objectives**

The objectives of this unit are to:

- i. Conclude our discussion of system software with language translators.
- ii. Discuss different categories of utility programs and application programs in greater detail.

### **3.0 Language Translator**

A programming language is a set of notations in which we express our instructions to the computer. At the initial stage of computer development, programs were written in machine language conducting the binary system i.e. 0 and 1. Such programs were hard to write, read, debug and maintain. In an attempt to solve these problems, other computer languages were developed. However, computers can run programs written only in machine language. There is therefore the need to translate programs written in these other languages to machine language. The suites of languages that translate other languages to machine language are called **Language Translator**. The initial program written in a language different from machine language is called the **source program** and its equivalent in machine language is called object program.

Three examples of classes of language translators are Assemblers, Interpreters and Compilers.

1. **Assemblers:** An Assembler is a computer program that accepts a source program in assembly language program reads and translates the entire program into an equivalent program in machine language called the object

program or object code. Each machine has its own assembly language, meaning that the assembly language of one machine cannot run on another machine.

2. **Interpreter:** An Interpreter is a program that accepts program in a source language, reads, translates and executes it, line by line into machine language.
3. **Compilers:** A Compiler is a computer program that accepts a source program in one high-level language, reads and translates the entire user's program into an equivalent program in machine language, called the object program or object code.

The stages in compilation include:

- Lexical analysis
- Syntax analysis
- Semantic analysis
- Code generation

For each high-level language, there are different compilers. We can therefore talk of COBOL Compilers, FORTRAN Compilers, BASIC Compilers, etc. A Compiler also detects syntax errors, errors that arise from the use of the language. Compilers are portable i.e. a COBOL Compiler on one machine can run on a different machine with minimum changes.

### 3.1 Utility Software

This is a set of commonly used programs in data processing departments also called service or general-purpose programs.

They perform the following operations.

- (i) **File Conversion:** This covers data transfer from any medium to another, making an exact copy or simultaneously editing and validating. For example, copying from a hard disk to a diskette.
- (ii) **File Copy:** It makes an exact copy of a file from one medium to another or from an area of a medium to another area of the same medium.

- (iii) **Housekeeping Operations:** These include programs to clear areas of storage, writing file labels and updating common data.

They are not involved in solving the problem at hand. They are operations that must be performed before and after actual processing.

### 3.2 Application software

Application software is a set of programs designed to solve problems of a specific nature. It could either be supplied by the computer manufacturer or in some cases, the users produce their own application program called USER PROGRAMS. Hence, an application software could be subdivided into two classes, namely; Generalized and User-defined Software.

Under the Generalized software, we have as examples: Word Processing Programs e.g. Word Perfect, Word Star, Microsoft word. Also, Desktop Publishing e.g. Ventura, PageMaker, CorelDraw likewise the Spreadsheet program e.g. LOTUS 1,2,3, Excel, Super-Q while under the User-defined, we could have some User-defined packages for a particular company or organization, for accounting, payroll or some other specialized purposes.

- (i) **Word Processor:** A Word Processor is used to create, edit, save and print reports. It affords the opportunity to make amendments before printing is done. During editing character, word sentence or a number of lines can be removed or inserted as the case may be. Another facility possible is spell checking. A document can be printed as many times as possible. Word processors are mainly used to produce: Letters, Mailing lists, Label, Greeting Cards, Business Cards, Reports, Manual, Newsletter. Examples are: WordPerfect, WordStar, Display Writer, Professional Writer, LOTUS Manuscript, Ms-Word, LOCO Script, MM Advantage II etc.
- (ii) **Spreadsheet:** Is an application mainly designed for numerical figures and reports. Spreadsheets contain columns and rows, in which numbers can be entered. It is possible to change numbers before

printing is done. Other features of spread sheets is the ability to use formulas to calculate, use sum and average function, ability to perform automatic recalculation and has the capacity to display reports in graphical modes. Spreadsheet is used for Budget, Tables, Cost analysis, Financial reports. Tax and Statistical analysis. Examples are: LOTUS 123, Supercalc, MS Multiplan, MS-excel, VP Planner etc.

- (iii) **Integrated Packages:** They are programs or packages that perform a variety of different processing operations using data that is compatible with whatever operation is being carried out. They perform a number of operations like Word Processing, Data-base Management and Spread sheeting. Examples are: Office writer, Logistic Symphony, Framework, Enable, Ability, Smart ware II, Microsoft Work V2.
- (iv) **Graphic Packages:** These are packages that enable you to bring out images, diagrams and pictures. Examples are PM, PM Plus, Graphic Writer, Photoshop.
- (v) **Database Packages:** It is software for designing, setting up and subsequently managing a database. (A database is an organized collection of data that allows for modification taking care of different users view). Examples are Dbase II, III, IV, FoxBASE, Rbase Data Perfect, Paradox III, Revelation Advanced and MS-Access.
- (vi) **Statistical Packages:** These are packages that can be used to solve statistical problems, e.g. Stat graphical, SPSS (Statistical Packages for Social Scientists).
- (vii) **Desktop Publishing:** These are packages that can be used to produce books and documents in standard form. Examples are PageMaker, Ventura, Publishers, Paints Brush, Xerox Form Base, News Master II, Dbase Publisher.
- (viii) **Game Packages:** These are packages that contain a lot of games for children and adults. Examples are Chess, Scrabble, Monopoly, Tune

Trivia, Star Trek 2, California Game, Soccer Game, War Game, Spy Catcher Dracula in London.

- (ix) **Communication Packages:** Examples are Carbon Plus, Data talk V3.3, Cross talk, SAGE Chit Chat, Data Soft.

There are so many packages around, virtually for every field of study but these are just to mention a few of them. Advantages of these packages include quick and cheaper implementation, time saving, minimum time for its design, they have been tested and proven to be correct, they are usually accompanied by full documentation and are also very portable.

### **User Programs**

This is a suit of programs written by programmers for computer users. They are required for the operation of their individual business or tasks. Example is a payroll package developed for salary operation of a particular company.

### **4.0 Conclusion**

Apart from the operating systems, we need program translators for us to be able to program and use the computer effectively. Since computers do not understand natural languages, there is the need to have language translators such as assemblers, interpreters and compilers. Utility programs such file conversion and scandisk on the other hand, enable us to maintain and enhance the operations of the computer. Application and user programs such as the word processors, spreadsheet and the like help us to perform specific tasks on the computer. These are discussed in full details in this unit.

### **5.0 Summary**

In unit, we have discussed the following:

- i. Language translators such as the assembler, interpreters and the compilers.

- ii. Utility programs such as file conversion, file copy programs and house keeping programs such as scandisk
- iii. Application programs such as word processors, spreadsheets and statistical packages.

## **6.0 Tutor Marked Assignment**

You have just been appointed as a consultant to a firm that is about to procure computing hardware and software. Recommend different categories of application packages that would be necessary for the smooth operations of the firm. Justify the need for each item recommended.

## **7.0 References and Further Reading**

Akinyokun, O.C, (1999). *Principles and Practice of Computing Technology*.

International Publishers Limited, Ibadan.

Balogun, V.F., Daramola, O.A., Obe, O.O., Ojokoh, B.A., and Oluwadare S.A., (2006).

*Introduction to Computing: A Practical Approach*. Tom-Ray Publications, Akure.

Francis Scheid (1983). *Schaum's Outline Series: Introduction to Computer Science*,

Mcgraw-Hill Book Company, Singapore

Tunji and Dokun (1993). *Data Processing, Principles and Concepts*. Informatics Books, Lagos.

## **MODULE 4: PROGRAMMING THE COMPUTER**

This topic shall be discussed under the following sub-topics:

- Computer programming languages
- Basic principles of computer programming
- Flowcharts
- Algorithms

### **STUDY UNIT 9: COMPUTER LANGUAGES**

#### **Table of content**

Low level language

Machine language

Assemblers

High level language

#### **1.0 Introduction**

In this unit, we shall take a look at computer programming with emphasis on:

- (a) The overview of computer programming languages.
- (b) Evolutionary trends of computer programming languages.
- (c) Programming computers in a Beginner All-Purpose Symbolic Instruction Code (BASIC) language environment with emphasis on:

#### **2.0 Objective**

The objective of this unit is to introduce the student to the background information about programming the Computer.

#### **3.0 Overview of Computer Programming Languages**

Basically, human beings cannot speak or write in computer language, and since computers cannot speak or write in human language, an intermediate language had to be devised to allow people to communicate with the computers. These intermediate languages, known as programming languages, allow a computer programmer to direct the activities of the computer. These languages are structured around unique set of rules

that dictate exactly how a programmer should direct the computer to perform a specific task. With the powers of reasoning and logic of human beings, there is the capability to accept an instruction and understand it in many different forms. Since a computer must be programmed to respond to specific instructions, instructions cannot be given in just any form. Programming languages standardize the instruction process. The rules of a particular language tell the programmer how the individual instructions must be structured and what sequence of words and symbols must be used to form an instruction.

- (a) An operation code.
- (b) Some operands.

The operation code tells the computer what to do such as add, subtract, multiply and divide. The operands tell the computer the data items involved in the operations. The operands in an instruction may consist of the actual data that the computer may use to perform an operation, or the storage address of data. Consider for example the instruction:  $a = b + 5$ . The '=' and '+' are operation codes while 'a', 'b' and '5' are operands. The 'a' and 'b' are storage addresses of actual data while '5' is an actual data.

Some computers use many types of operation codes in their instruction format and may provide several methods for doing the same thing. Other computers use fewer operation codes, but have the capacity to perform more than one operation with a single instruction. There are four basic types of instructions namely:

- (a) input-output instructions;
- (b) arithmetic instructions;
- (c) branching instructions;
- (d) logic instructions.

An input instruction directs the computer to accept data from a specific input device and store it in a specific location in the store. An output instruction tells the computer to move a piece of data from a computer storage location and record it on the output medium.

All of the basic arithmetic operations can be performed by the computer. Since arithmetic operations involve at least two numbers, an arithmetic operation must include at least two operands.



Branch instructions cause the computer to alter the sequence of execution of instruction within the program. There are two basic types of branch instructions; namely unconditional branch instruction and conditional branch instruction. An unconditional branch instruction or statement will cause the computer to branch to a statement regardless of the existing conditions. A conditional branch statement will cause the computer to branch to a statement only when certain conditions exist.

Logic instructions allow the computer to change the sequence of execution of instruction, depending on conditions built into the program by the programmer. Typical logic operations include: shift, compare and test.

### **3.1 Types of Programming Language**

The effective utilization and control of a computer system is primarily through the software of the system. We note that there are different types of software that can be used to direct the computer system. System software directs the internal operations of the computer and applications software allows the programmer to use the computer to solve user made problems. The development of programming techniques has become as important to the advancement of computer science as the developments in hardware technology. More sophisticated programming techniques and a wider variety of programming languages have enabled computers to be used in an increasing number of applications.

Programming languages, the primary means of human-computer communication, have evolved from early stages where programmers entered instructions into the computer in a language similar to that used in the application. Computer programming languages can be classified into the following categories:

- (a) Machine language
- (b) Assembly language
- (c) High level symbolic language
- (d) Very high level symbolic language.

### **3.1.1 Machine Language**

The earliest forms of computer programming were carried out by using languages that were structured according to the computer stored data, that is, in a binary number system. Programmers had to construct programs that used instructions written in binary notation 1 and 0. Writing programs in this fashion is tedious, time-consuming and susceptible to errors.

Each instruction in a machine language program consists, as mentioned before, of two parts namely: operation code and operands. An added difficulty in machine language programming is that the operands of an instruction must tell the computer the storage address of the data to be processed. The programmer must designate storage locations for both instructions and data as part of the programming process. Furthermore, the programmer has to know the location of every switch and register that will be used in executing the program, and must control their functions by means of instructions in the program.

A machine language program allows the programmer to take advantage of all the features and capabilities of the computer system for which it was designed. It is also capable of producing the most efficient program as far as storage requirements and operating speeds are concerned. Few programmers today write applications programs in machine language. A machine language is computer dependent. Thus, an IBM machine language will not run on NCR machine, DEC machine or ICL machine. A machine language is the First Generation (computer) Language (IGL).

### **3.1.2 Assembly (Low Level) Language**

Since machine language programming proved to be a difficult and tedious task, a symbolic way of expressing machine language instructions is devised. In assembly language, the operation code is expressed as a combination of letters rather than binary numbers, sometimes called mnemonics. This allows the programmer to remember the operations codes easily than when expressed strictly as binary numbers. The storage address or location of the operands is expressed as a symbol rather than the actual numeric address. After the computer has read the program, operations software are used

to establish the actual locations for each piece of data used by the program. The most popular assembly language is the IBM Assembly Language.

Because the computer understands and executes only machine language programs, the assembly language program must be translated into a machine language. This is accomplished by using a system software program called an assembler. The assembler accepts an assembly language program and produces a machine language program that the computer can actually execute. The schematic diagram of the translation process of the assembly language into the machine language is shown in the below diagram. Although, assembly language programming offers an improvement over machine language programming, it is still an arduous task, requiring the programmer to write programs based on particular computer operation codes. An assembly language program developed and run on IBM computer would fail to run on ICL computers. Consequently, the portability of computer programs in a computer installation to another computer installation which houses different makes or types of computers were not possible. The low level languages are, generally, described as Second Generation (computer) Language (2GL).

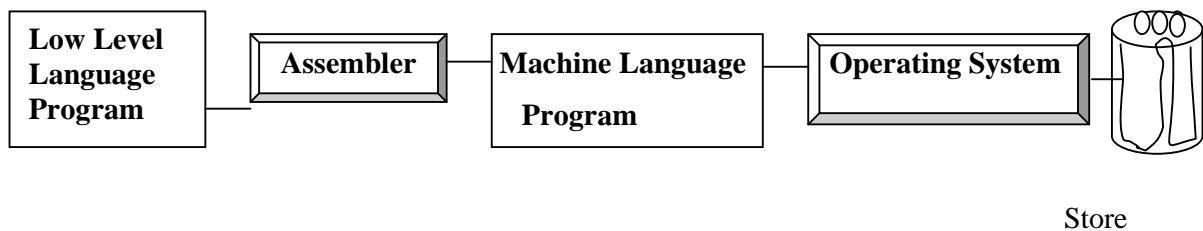
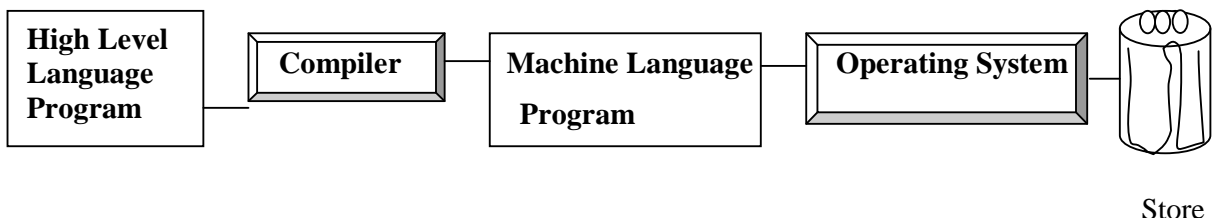

**Fig. 1: Assembly Language Program Translation Process**

### **3.1.3 High Level Language**

The difficulty of programming and the time required to program computers in assembly languages and machine languages led to the development of high-level languages. The symbolic languages, sometimes referred to as problem oriented languages reflect the type of problem being solved rather than the computer being used to solve it. Machine and assembly language programming is machine dependent but high level languages are machine independent, that is, a high-level language program can be run on a variety of computer.

While the flexibility of high level languages is greater than that of the machine and assembly languages, there are close restrictions in exactly how instructions are to be formulated and written. Only a specific set of numbers, letters, and special characters may be used to write a high level program and special rules must be observed for punctuation. High level language instructions do resemble English language statements and the mathematical symbols used in ordinary mathematics. Among the existing and popular high level programming languages are Fortran, Basic, Cobol, Pascal, Algol, Ada and P1/1. The schematic diagram of the translation process of a high level language into the machine language is shown in the diagram below. The high level languages are, generally, described as Third Generation (computer) Language (3GL).



**Fig. 2: High Level Language Program Translation Process**

The general procedure for the compilation of a computer program coded in any high level language is conceptualized in the above diagram.

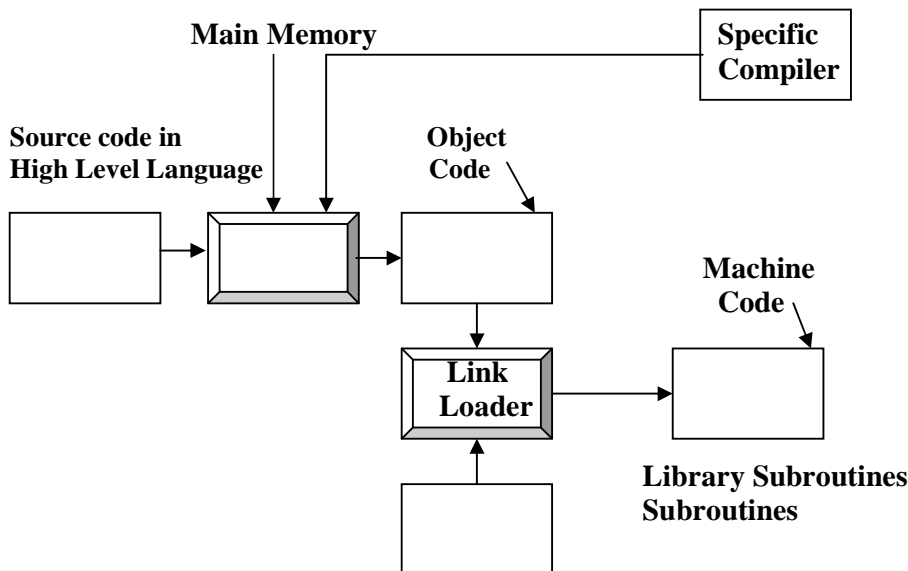

**Fig. 3: General Procedure for Compiling High Level Language Program**

### 3.1.4 Very High Level Language

Programming aids or programming tools are provided to help programmers do their programming work more easily. Examples of programming tools are:

- (a) Program development systems that help users to learn programming, and to program in a powerful high level language. Using a computer screen (monitor) and keyboard under the direction of an interactive computer program, users are helped to construct application programs.
- (b) A program generator or application generator that assists computer users to write their own programs by expanding simple statements into program code'.
- (c) Database management system.
- (d) Debuggers that are programs that help computer user to locate errors (bugs) in the application programs they write.

The very high level language generally described as the Fourth Generation (computer) Language (4GL), is an ill-defined term that refers to software intended to help computer users or computer programmers to develop their own application programs more quickly and cheaply. A 4GL, by using a menu system for example, allows users to specify what they require, rather than describe the procedures by which these requirements are met. The detail procedure by which the requirements are met is done by the 4GL software which is transparent to the users.

A 4GL offers the user an English-like set of commands and simple control structures in which to specify general data processing or numerical operations. A program is translated into a conventional high-level language such as Cobol, which is passed to a compiler. A 4GL is, therefore, a non-procedural language. The program flows are not designed by the programmer but by the fourth generation software itself. Each user request is for a result rather than a procedure to obtain the result. The conceptual diagram of the translation process of very high level language to machine language is given in the diagram below.

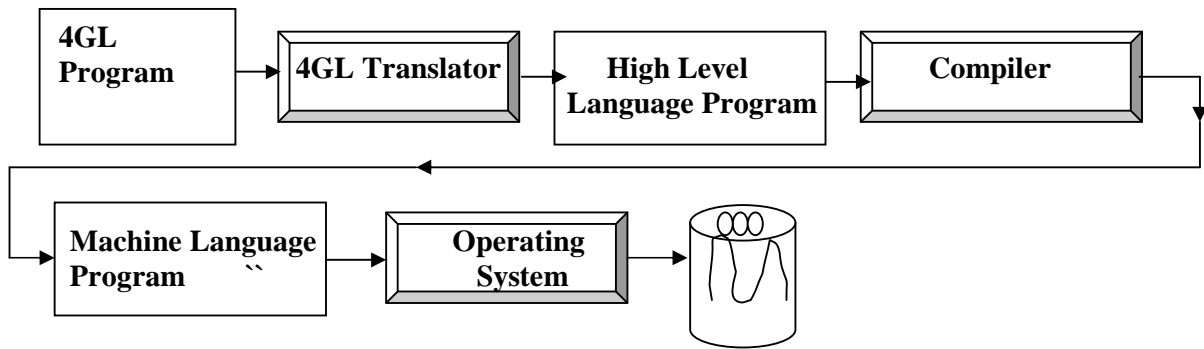

**Fig. 4: Program Translation Process**

The 4GL arose partly in response to the applications backlog. A great deal of programming time is spent maintaining and improving old programs rather than building new ones. Many organizations, therefore, have a backlog of applications waiting to be developed. 4GL, by stepping up the process of application design and by making it easier for end-users to build their own programs, helps to reduce the backlog.

#### **4.0 Conclusion**

Computer programming languages are means by which programmers manipulate the computer. The programming languages emanates from the need to program the computer in languages that would be easy for non-experts to understand and to reduce the enormity of task involved in writing programs in machine code. Programming languages have evolved from the machine language to assembly language, high level language and very high level programming language.

#### **5.0 Summary**

We summarize the study of computer programming language as follows:

- (a) Machine language is the binary language and its made up of only 0s and 1s which represent the ‘off’ and ‘on’ stages of a computer’s electrical circuits.
- (b) Assembly language has a one-to-one relationship with machine language, but uses symbols and mnemonics for particular items. Assembly language, like machine language, is hardware specific, and is translated into machine language by an assembler.
- (c) High level languages are usable on different machines and are designed for similar applications rather than similar hardware. They are procedural in that

they describe the logical procedures needed to achieve a particular result. High level languages are translated into machine language by a compiler or an interpreter.

- (d) In a high level language one specifies the logical procedures that have to be performed to achieve a result. In a fourth generation language, one needs to simply define the result one wants, and the requisite program instructions will be generated by the fourth generation software. Fourth generation languages are used in fourth generation systems in which a number of development tools are integrated in one environment.

### **6.0 Tutor Marked Assignment**

- a) What are computer programming languages?
- b) Explain the following terms: machine language, source code, assembler, and compiler.

### **7.0 References and Further Reading**

Akinyokun, O.C, (1999). *Principles and Practice of Computing Technology*.

International Publishers Limited, Ibadan.

Balogun, V.F., Daramola, O.A., Obe, O.O., Ojokoh, B.A., and Oluwadare S.A., (2006).

*Introduction to Computing: A Practical Approach*. Tom-Ray Publications, Akure.

Francis Scheid (1983). *Schaum's Outline Series: Computers and Programming*. McGraw-Hill Book Company, Singapore.

Chuley, J.C. (1987). *Introduction to Low Level Programming for Microprocessors*. Macmillan Education Ltd.

Holmes, B.J. (1989). *Basic Programming*, 3<sup>rd</sup> Edition, ELBS.

## **STUDY UNIT 10: BASIC PRINCIPLES OF COMPUTER PROGRAMMING**

### **Table of Content**

Problem solving with Computer.

Principles of programming.

Stages of programming.

### **1.0 Introduction**

Computer programming is both an art and a science. In this unit, we students shall be exposed to some arts and science of computer programming including principles of programming and stages of programming.

### **2.0 Objectives**

The objective of this unit is to expose students to the principles of programming and the stages involved in writing computer programs.

### **3.0 Problem Solving With The Computer**

The computer is a general-purpose machine with a remarkable ability to process information. It has many capabilities, and its specific function at any particular time is determined by the user. This depends on the program loaded into the computer memory being utilized by the user.

There are many types of computer programs. However, the programs designed to convert the general-purposes computer into a tool for a specific task or applications are called 'Application programs'. These are developed by users to solve their peculiar data processing problems.

Computer programming is the act of writing a program which a computer can execute to produce the desired result. A program is a series of instructions assembled to enable the computer to carry out a specified procedure. A computer program is the sequence of simple instructions into which a given problem is reduced and which is in a form the computer can understand, either directly or after interpretation.

### **3.1 Programming Methodology**

#### **Principles of good Programming**

It is generally accepted that a good Computer program should have the characteristics shown below:



**Accuracy:** The Program must do what it is supposed to do correctly and must meet the criteria laid down in its specification.

**Reliability:** The Program must always do what it is supposed to do, and never crash.

**Efficiency:** Optimal utilization of resources is essential. The program must use the available storage space and other resources in such a way that the system speed is not wasted.

**Robustness:** The Program should cope with invalid data and not stop without an indication of the cause of the source of error.

**Usability:** The Program must be easy enough to use and be well documented.

**Maintainability:** The Program must be easy to amend having good structuring and documentation.

**Readability:** The Code of a program must be well laid out and explained with comments.

### **3.2 Stages of Programming**

The preparation of a computer program involves a set of procedure.

These steps can be classified into eight major stages, viz

- (i) Problem Definition
- (ii) Devising the method of solution
- (iii) Developing the method using suitable aids, e.g. pseudo code or flowchart.
- (iv) Writing the instructions in a programming language
- (v) Transcribing the instructions into “machine sensible” form
- (vi) Debugging the program
- (vii) Testing the program
- (viii) Documenting all the work involved in producing the program.

#### **(i) Problem definition**

The first stage requires a good understanding of the problem. The programmer (i.e. the person writing the program) needs to thoroughly understand what is required of a problem. A complete and precise unambiguous statement of the problem to be solved must be stated. This will entail the detailed specification which lays down the input, processes and output-required.

**(ii) Devising the method of solution**

The second stage involved is spelling out the detailed algorithm. The use of a computer to solve problems (be it scientific or business data processing problems) requires that a procedure or an algorithm be developed for the computer to follow in solving the problem.

**(iii) Developing the method of solution**

There are several methods for representing or developing methods used in solving a problem. Examples of such methods are: algorithms, flowcharts, pseudo code, and decision tables.

**(iv) Writing the instructions in a programming language**

After outlining the method of solving the problem, a proper understanding of the syntax of the programming language to be used is necessary in order to write the series of instructions required to get the problem solved.

**(v) Transcribing the instructions into machine sensible form**

After the program is coded, it is converted into machine sensible form or machine language. There are some manufacturers written programs that translate users program (source program) into machine language (object code). These are called translators and instructions that machines can execute at a go, while interpreters accept a program and executes it line-by-line.

During translation, the translator carries out syntax check on the source program to detect errors that may arise from wrong use of the programming language.

**(vi) Program debugging**

A program seldomly executes successfully the first time. It normally contains a few errors (bugs). Debugging is the process of locating and correcting errors. There are three classes of errors.

- (i) Syntax errors:** Caused by mistake coding (illegal use of a feature of the programming language).
- (ii) Logic errors:** Caused by faulty logic in the design of the program. The program will work but not as intended.
- (iii) Execution errors:** The program works as intended but illegal input or other circumstances at run-time makes the program stop. There are two basic levels of debugging. The first level called desk checking or dry running is performed after the program has been coded and entered or key punched. Its

purpose is to locate and remove as many logical and clerical errors as possible.

The program is then read (or loaded) into the computer and processed by a language translator. The function of the translator is to convert the program statements into the binary code of the computer called the object code. As part of the translation process, the program statements are examined to verify that they have been coded correctly, if errors are detected, a series of diagnostics referred to as an error message list is generated by the language translator. With this list in the hand of programmer, enters the second level of debugging is reached.

The error message list helps the programmer to find the cause of errors and make the necessary corrections. At this point, the program may contain entering errors, as well as clerical errors or logic errors. The programming language manual will be very useful at this stage of program development.

After corrections have been made, the program is again read into the computer and again processed by the language translator. This is repeated over and over again until the program is error-free.

#### **(vii) Program testing**

The purpose of testing is to determine whether a program consistently produces correct or expected results. A program is normally tested by executing it with a given set of input data (called test data), for which correct results are known.

For effective testing of a program, the testing procedure is broken into three segments.

- (a) The program is tested with inputs that one would normally expect for an execution of the program.
- (b) Valid but slightly abnormal data is injected (used) to determine the capabilities of the program to cope with exceptions. For example, minimum and maximum values allowable for a sales-amount field may be provided as input to verify that the program processed them correctly.
- (c) Invalid data is inserted to test the program's error-handling routines. If the result of the testing is not adequate, then minor logic errors still

abound in the program. The programmer can use any of these three alternatives to locate the bugs.

Other methods of testing a program for correctness include:

- ❖ **Manual walk-through:** The programmer traces the processing steps manually to find the errors, pretending to be the computer, following the execution of each statement in the program, noting whether or not the expected results are produced.
- ❖ **Use of tracing routines:** If this is available for the language, this is similar to (1) above but it is carried out by the computer hence it takes less time and it is not susceptible to human error.
- ❖ **Storage dump:** This is the printout of the contents of the computers storage locations. By examining the contents of the various locations, the instruction at which the program is halted can be determined. This is an important clue to finding the error that caused the halt, when a program is halted.
- ❖ **Program documentation:** Documentation of the program should be developed at every stage of the programming cycle. The following are documentations that should be done for each program.

**(a) Problem Definition Step**

- A clear statement of the problem
- The objectives of the program (what the program is to accomplish)
- Source of request for the program.
- Person/official authorizing the request.

**(b) Planning the Solution Step**

- Flowchart, pseudocode or decision tables
- Program narrative
- Descriptive of input, and file formats

**(c) Program source coding sheet**

**(d) User's manual to aid persons who are not familiar with the program to apply it correctly.**

It contains a description of the program and what it is designed to achieve.

- (e) Operator's manual to assist the computer operator to successfully run the program. This manual contains:
  - (i) Instructions about starting, running and terminating the program.
  - (ii) Message that may be printed on the console or VDU (terminal) and their meanings.
  - (iii) Setup and take down instruction for files.

#### **Advantages of Program documentation**

- (i) It provides all necessary information for anyone who comes in contact with the program.
- (ii) It helps the supervisor in determining the program's purpose, how long the program will be useful and future revision that may be necessary.
- (iii) It simplifies program maintenance (revision or updating)
- (iv) It provides information as to the use of the program to those unfamiliar with it.
- (v) It provides operating instructions to the computer operator.

#### **4.0 Conclusion**

The intelligence of a computer derives to a large extent from the quality of the programs. In this unit, we have attempted to present in some details, the principles and the stages involved in writing a good computer program.

#### **5.0 Summary**

In this unit we have discussed the following:

- i. Principles of computer programming.
- ii. Stages of computer programming.
- iii. The interrelationship between different stages of programming.

#### **6.0 Tutor Marked Assignment**

- i. Differentiate between program debugging and program testing.
- ii. What are the differences between syntax errors and logic errors. Give examples of each.
- iii. Is it possible to detect logic error during program compilation? Explain the reason for your answer.

## **7.0 References and Further Reading**

Akinyokun, O.C, (1999). *Principles and Practice of Computing Technology*.

International Publishers Limited, Ibadan.

Balogun, V.F., Daramola, O.A., Obe, O.O., Ojokoh, B.A., and Oluwadare S.A., (2006).

*Introduction to Computing: A Practical Approach*. Tom-Ray Publications, Akure.

Holmes, B.J. (1989). *Basic Programming*, 3<sup>rd</sup> Edition, ELBS.

Francis Scheid (1983). *Schaum's Outline Series: Computers and Programming*.  
Mcgraw-Hill Book Company, Singapore.

Chuley, J.C. (1987). *Introduction to Low Level Programming for Microprocessors*.  
Macmillan Education Ltd.

## **STUDY UNIT 11: FLOWCHART AND ALGORITHMS**

### **Table of Content**

Flowchart

Algorithms

### **1.0 Introduction**

In this unit you are introduced to the principles of flowcharts and algorithms. The importance of these concepts are presented and the detailed steps and activities involved are also presented.

### **2.0 Objectives**





The objective of this unit is to enable the student grasp the principles of good programming ethics through flowcharting and algorithms.

### **3.0 Flowchart**

A Flowchart is a graphical representation of the major steps of work in process. It displays in separate boxes the essential steps of the program and shows by means of arrows the directions of information flow. The boxes most often referred to as illustrative symbols may represent documents, machines or actions taken during the process. The area of concentration is on where or who does what, rather than on how it is done. A flowchart can also be said to be a graphical representation of an algorithm, that is, it is visual picture which gives the steps of an algorithm and also the flow of control between the various steps.

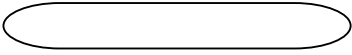
#### **3.1 Flowchart Symbols**

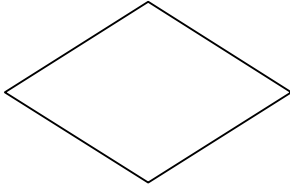
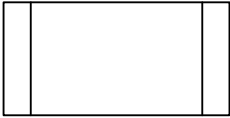
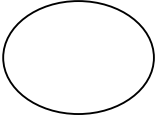
Flowcharts are drawn with the help of symbols. The following are the most commonly used flowchart symbols and their functions:

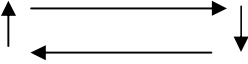
Symbols	Function
 <p><b>Terminator</b></p>	<p>Used to show the START or STOP point. May show exit to a closed subroutine.</p>
	<p>Used for arithmetic calculations of process. E.g. <math>\text{Sum} = X + Y + Z</math></p>
	<p>Used for Input and Output instructions, PRINT, READ, INPUT AND WRITE.</p>
	<p>Used for decision making. Has two or more lines leaving the box. These lines are labeled with different decision results, that is, 'Yes', 'No', 'TRUE' or 'FALSE' or 'NEGATIVE' or 'ZERO'.</p>
	<p>Used for one or more named operations or program steps specified in a subroutine or another set of flowchart.</p>
	<p>Used for entry to or exit from another part of flowchart. A small circle identifies a junction point of the program</p>
	<p>Used for entry to or exit from a page</p>
	<p>Used to show the direction of travel. They are used in linking symbols. These show operations sequence and data flow directions.</p>

### 3.2 Guidelines for drawing flowcharts

- (i) Each symbol denotes a type of operation Input, Output, Processing, Decision, Transfer or branch or Terminal.
- (ii) A note is written inside each symbol to indicate the specific function to be performed.
- (iii) Flowcharts are read from top to bottom.
- (iv) A sequence of operations is performed until a terminal symbol designates the end of the run or “branch” connector transfers control.



### 3.3 Flowcharting the Problem

The digital computer does not do any thinking and cannot make unplanned decisions. Every step of the problem has to be taken care of by the program. A problem which can be solved by a digital computer need not be described by an exact mathematical equation, but it does need a certain set of rules that the computer can follow. If a problem needs intuition or guessing, or is so badly defined that it is hard to put into words, the computer cannot solve it. You have to define the problem and set it up for the computer in such a way that every possible alternative is taken care of. A typical flowchart consists of special boxes, in which are written the activities or operations for the solution of the problem. The boxes linked by means of arrows which show the sequence of operations. The flowchart acts as an aid to the Programmer who follows the flowchart design to write his programs.

### 3.4 Algorithms

Before a computer can be put to any meaningful use, the user must be able to come out with or define a unit sequence of operations or activities (logically ordered) which gives an unambiguous method of solving a problem or finding out that no solution exists. Such a set of operations is known as an ALGORITHM.

**Definition:** An algorithm, named after the ninth century scholar Abu Jafar Muhammad Ibn Musu Al-Khowarizmi , is defined as follows: Roughly speaking:

- An algorithm is a set of rules for carrying out calculation either by hand or a machine.
- An algorithm is a finite step-by-step procedure to achieve a required result.
- An algorithm is a sequence of computational steps that transform the input into the output.
- An algorithm is a sequence of operations performed on data that have to be organized in data structures.
- An algorithm is an abstraction of a program to be executed on a physical machine (model of computation)

The most famous algorithm in history dates well before the time of the ancient Greeks: this is Euclids algorithm for calculating the greatest common divisor of two integers. Before we go into some otherwise complex algorithms, let us consider one of the simplest but common algorithms that we encounter everyday.

The classic multiplication algorithm

For example to multiply 981 by 1234, this can be done using two methods (algorithms) viz:

a. Multiplication the American way:

Multiply the multiplicand one after another by each digit of the multiplier taken from right to left.

$$\begin{array}{r} 981 \\ 1234 \\ \hline 3924 \\ 2943 \\ 1962 \\ 981 \\ 1210554 \\ \hline \end{array}$$

b. Multiplication , the British way:

Multiply the multiplicand one after another by each digit of the multiplier taken from left to right.

$$\begin{array}{r} 981 \\ 1234 \\ \hline 981 \\ 1962 \\ 2943 \\ 3924 \\ 1210554 \\ \hline \end{array}$$

An algorithm therefore can be characterized by the following:

- (i) A finite set or sequence of actions
- (ii) This sequence of actions has a unique initial action
- (iii) Each action in the sequence has unique successor

- (iv) The sequence terminates with either a solution or a statement that the problem is unresolved.

An algorithm can therefore be seen as a step-by-step method of solving a problem.

**Examples**

- 1. Write an algorithm to read values for three variables. U, V, and W and find a value for RESULT from the formula:  $RESULT = U + V^2/W$ . Draw the flowchart.

**Solution:**

**Algorithm**

- (i) Input values for U, V, and W
- (ii) Computer value for result
- (iii) Print value of result
- (iv) Stop

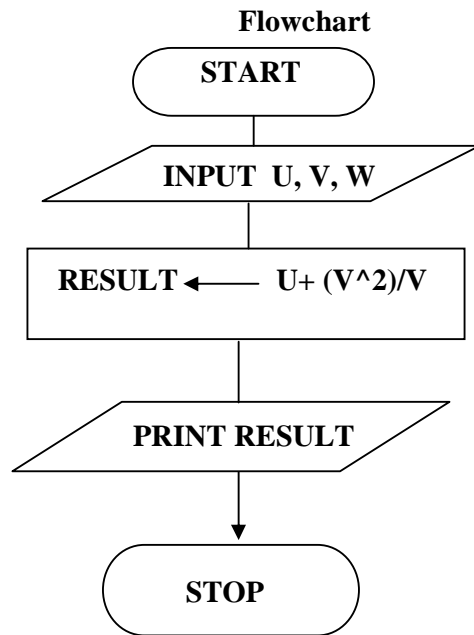

- 2. Suppose you are given 20 numbers. Prepare the algorithm that adds up these numbers and find the average. Draw the flowchart.

**Solution:**

**Algorithm**

- (i) Set up a Counter (1) which counts the number of times the loop is executed. Initialize Counter (1) to 1.
- (ii) Initialize sum to Zero
- (iii) Input value and add to sum

- (iv) Increment the Counter (1) by 1
- (v) Check how many times you have added up the number (if it is not up to the required number of times, to step (iii)).
- (vi) Computer the average of the numbers
- (vii) Print the average
- (viii) Stop.

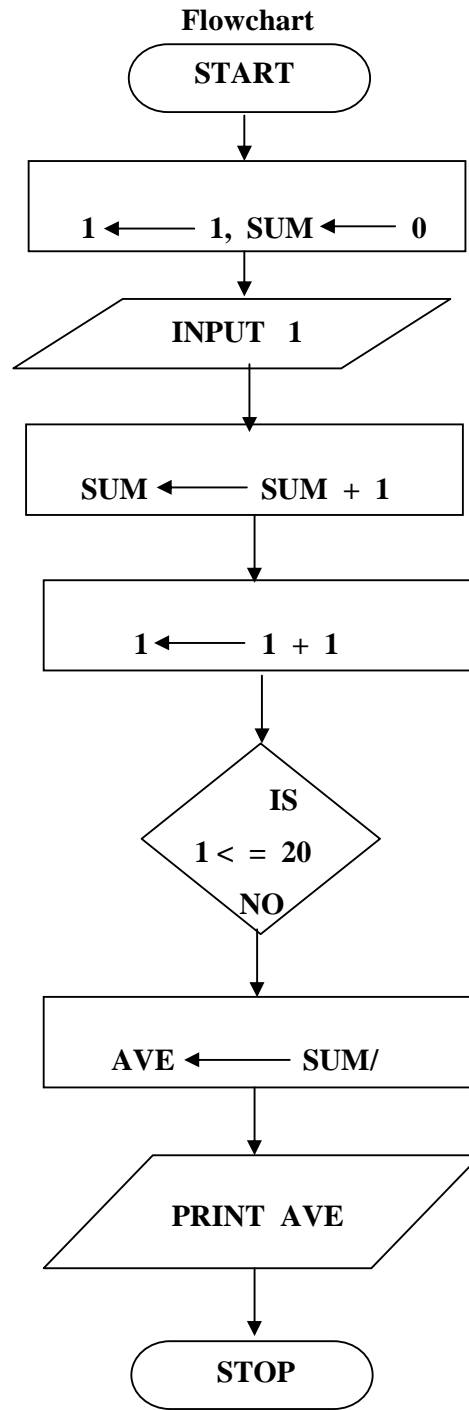

3. Prepare an algorithm that indicates the logic for printing the name and telephone number for each female in a file (Code field is 2 for female). Draw the flowchart.

**Solution:**

**Algorithm**

- (i) Read a record
- (ii) Determine if the record pertains to a female (that is, determine if the code field is equal to 2).
- (iii) If the code field is not equal to 2, then do not process this record any further, since it contains data for a male. Instead, read the next record; that is, go back to step (i).
- (iv) If the record contains data for a female (that is, code is equal to 2), then print out the following fields: first name, last name, telephone number
- (v) Go back to step (i) to read the next record.

**Flowchart**

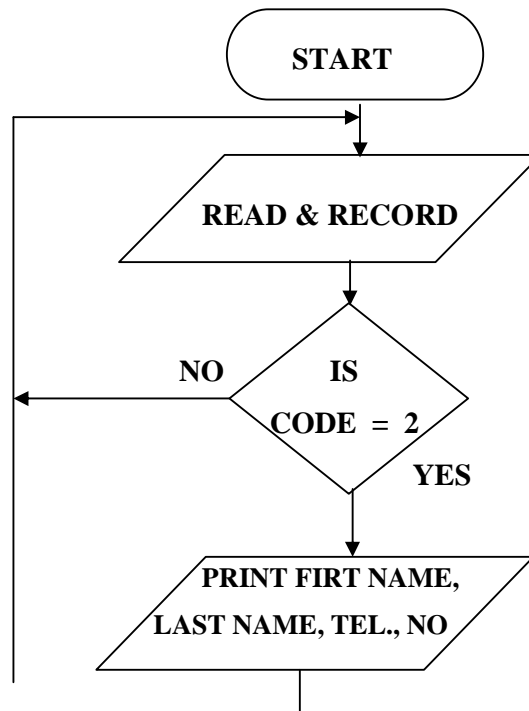

**Note:** Nothing indicates the end of records processing here.

4. Prepare an algorithm that prints name and weekly wages for each employee out of 10 where name, hours worked, and hourly rate are read in. Draw the flowchart.

**Solution:**

**Algorithm**

- (i) Initialize Counter (A) to 1
- (ii) Read name, hours and rate and number of workers
- (iii) Let the wage be assigned the product of hours and rate
- (iv) Print name and wages
- (v) Increment the counter (A) by 1
- (vi) Make a decision (Check how many times you have calculated the wages)
- (vii) Stop processing, if you have done it the required number of times.

**Flowchart**

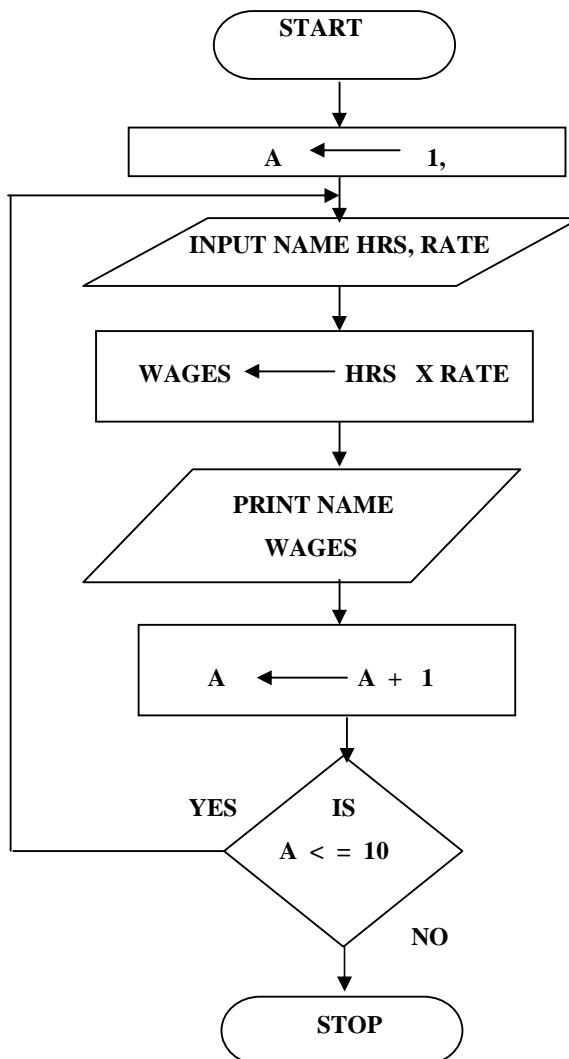

### **3.5 Pseudocode**

Pseudocode is a program design aid that serves the function of a flowchart in expressing the detailed logic of a program. Sometimes a program flowchart might be inadequate for expressing the control flow and logic of a program. By using Pseudocode, program algorithm can be expressed as English-language statements. These statements can be used both as a guide when coding the program in specific language and as documentation for review by others. Because there is no rigid rule for constructing pseudocodes, the logic of the program can be expressed in a manner without confronting to any particular programming language. A series of structured words is used to express the major program functions. These structured words are the basis for writing programs using a technical term called “structure programming”.

#### **Example:**

Construct Pseudocode for the problem in the example above.

```
BEGIN
STORE 0 TO SUM
STORE 1 TO COUNT
      DO WHILE COUNT not greater than 10
      ADD COUNT to SUM
      INCREMENT COUNT by 1
      ENDWILE
END
```

### **3.6 Decision Tables**

Decision tables are used to analyze a problem. The conditions applying in the problem are set out and the actions to be taken, as a result of any combination of the conditions arising are shown. They are prepared in conjunction with or in place of flowcharts. Decision tables are a simple yet powerful and unambiguous way of showing the actions to be taken when a given set of conditions occur. Moreover, they can be used to verify that all conditions have been properly catered for. In this way they can reduce the possibility that rare or unforeseen combinations of conditions will result in confusion about the actions to be taken.

Decision tables have standardized format and comprise of four sections.

- (a) **Conditions Stub:** This section contains a list of all possible conditions which could apply in a particular problem.
- (b) **Condition Entry:** This section contains the different combination of the conditions each combination being given a number termed a 'Rule':
- (c) **Action Stub:** This section contains a list of the possible actions which could apply for any given combinations of conditions.

**Action Entry:** This section shows the actions to be taken for each combination of conditions. **Writing the instructions in a programming language (Program coding)**

The instructions contained in the algorithm must be communicated to the computer in a language it will understand before it can execute them. The first step is writing these instructions in a programming language (Program coding). Program coding is the process of translating the planned solution to the problems, depicted in a flowchart, pseudocode or decision table, into statements of the program. The program flowchart, pseudocode decision table as the case may be is as a guide by the programmer as he describes the logic in the medium of a programming language. The coding is usually done on coding sheets or coding forms.

#### **4.0 Conclusion**

Flowcharts, decision tables, pseudocodes and algorithms are essential ingredients to the writing of good programs. If they are done properly they lead to reduction in errors in programs. They help minimize the time spent in debugging. In addition, they make logic errors easier to trace and discovered.

#### **5.0 Summary**

In this unit we have learnt that:

- i. A Flowchart is a graphical representation of the major steps of work in process. It displays in separate boxes the essential steps of the program and shows by means of arrows the directions of information flow.
- ii. Decision tables are used to analyze a problem. The conditions applying in the problem are set out and the actions to be taken, as a result of any combination of the conditions arising are shown.
- iii. Pseudocode is a program design aid that serves the function of a flowchart in expressing the detailed logic of a program.



- iv. An algorithm is a set of rules for carrying out calculation either by hand or a machine.

### **6.0 Tutor Marked Assignment**

1. Draw the flowchart of the program which prints each two-digit odd number N, its square, and its cube.
2. Draw a flowchart to input the scores of a student in 8 courses and find the average of the scores.

### **7.0 References and Further Reading**

Akinyokun, O.C, (1999). *Principles and Practice of Computing Technology*.

International Publishers Limited, Ibadan.

Balogun, V.F., Daramola, O.A., Obe, O.O., Ojokoh, B.A., and Oluwadare S.A., (2006).

*Introduction to Computing: A Practical Approach*. Tom-Ray Publications, Akure.

Francis Scheid (1983). *Schaum's Outline Series: Computers and Programming*. McGraw-Hill Book Company, Singapore.

Chuley, J.C. (1987). *Introduction to Low Level Programming for Microprocessors*. Macmillan Education Ltd.

Gray S. Popkin and Arthur H. Pike (1981). (1981). *Introduction to Data Processing with BASIC*, 2<sup>nd</sup> edition, Houghton Mifflin Company, Boston.

## **MODULE 5: COMPUTER APPLICATION PROGRAMMING USING VISUAL BASIC**

In this module you will learn about:

- Object Oriented Programming (OOP)
- The Visual Basic Project Window
- Creating Menu Applications
- Analysing Visual Basic Data

### **STUDY UNIT 12: PROGRAMMING IN VISUAL BASIC (1)**

#### **Table of content**

Learning to run Visual Basic Applications

How to design a project from the application wizard.

Using the Toolbox

The form window

#### **1.0 Introduction**

Visual is an event driven language which has some features of Object Oriented Programming (OOP). Actions are tied to the occurrence of events e.g. an action may be triggered by clicking the mouse. This approach makes application programs more friendly and natural to the end user. In this unit students are introduced to the concept of working with graphical objects and the general Visual Basic Programming concepts.

#### **2.0 Objectives**

The objective of this unit is to introduce students to:

- i. The concept of working with graphical objects and the general Visual Basic Programming concepts.

- ii. How to design a project from the application wizard and,
- iii. How to use the toolbox.

### 3.0 Learning To Run Visual Basic Applications

These sessions will include learning how to work with graphical objects in the Visual Basic Environment and using general Visual Basic Programming concepts.

#### How To Design A Project From The Application Wizard.

A *project* is a collection of files that make up your application. A single application might consist of several files, and the project is the collection of those files.

The application wizard can be selected from the New Project dialog box. If you cancel the New Project dialog box, and then later want to start the Application wizard, select File, New Project to display the New Project dialog box once again. The screen you see looks like that in Figure 1.

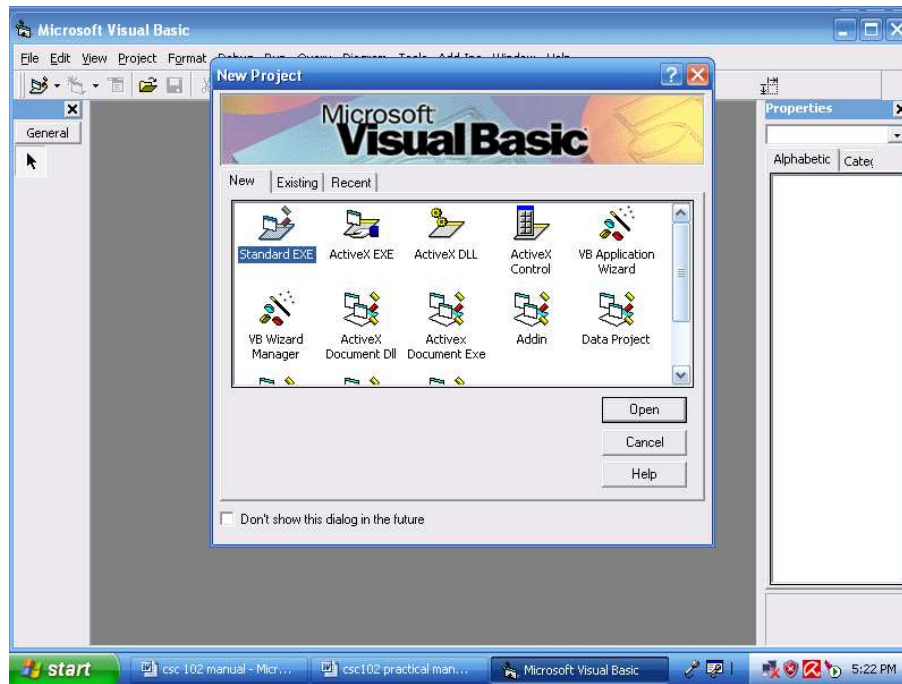

Figure 1

When you select the icon labeled VB Application Wizard on the New tab, the wizard begins its work. The interface type you select will determine how your application will process multiple windows. See figure 2.

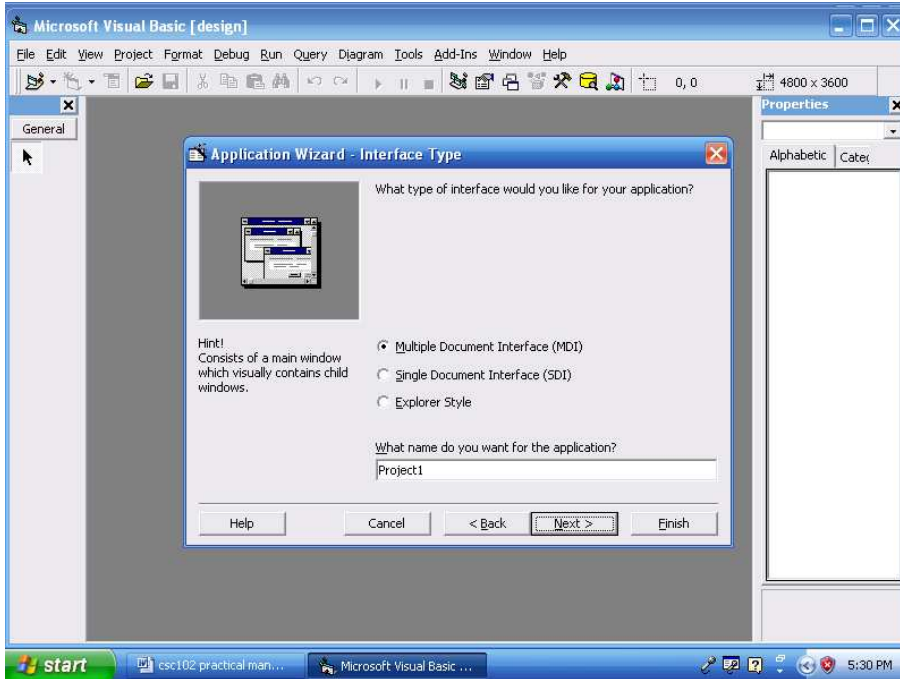

Figure 2

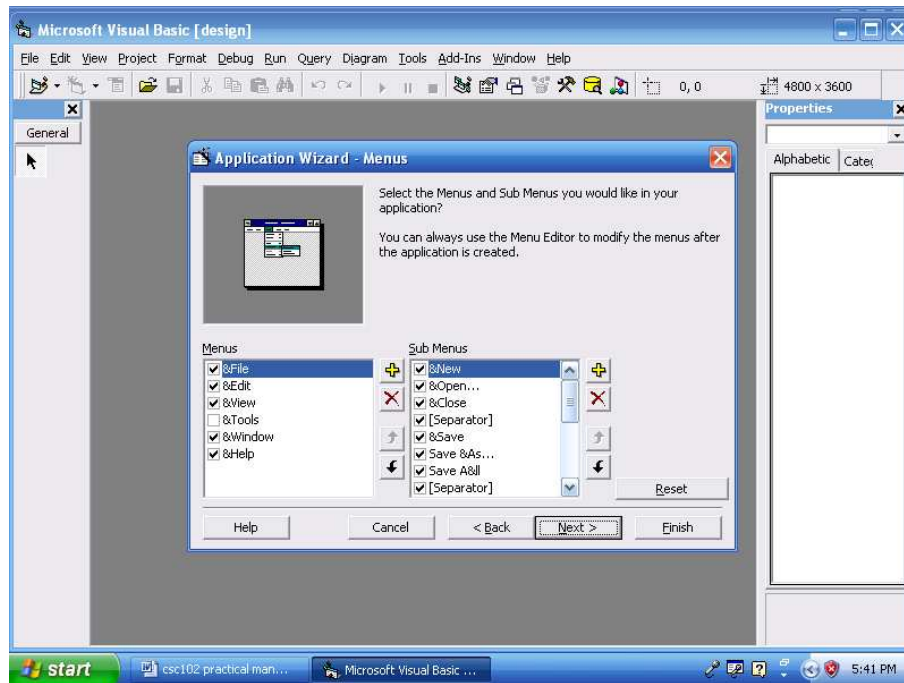
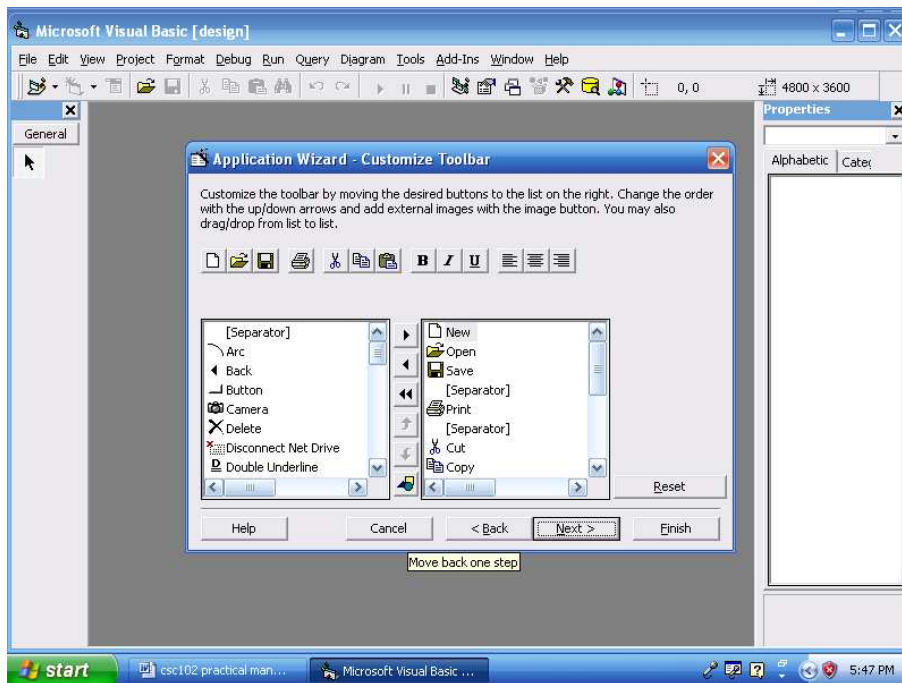

Figure 3

You can select the options you want your application's menu to contain as shown in Figure 3 above. The options are common Windows options found on most Windows programs. The ampersand (&) next to a letter in a menu name indicates the underscored accelerator key letter; in other words, &New indicates that New appears on the menu and that the user can select the option by pressing Alt+N.

The next wizard screen, shown in Figure 4, lets you select the toolbar buttons that your application will have. Click next to accept all the default toolbar settings.



**Figure 4**

The next wizard screen to appear is the Resource screen from which you can select to use resources in your program. The next one is the Internet Connectivity screen from which you can add an Internet interface to your program if you want one. The next screen gives the option of adding one of these standard screens to your application:

- **Splash screen** is an opening title screen that appears when your application first begins.

- **Login dialog** is a dialog box that asks for the user's ID and password as a part of application security that you can add.
- **Options dialog** is tabbed blank dialog box from which your users can specify attributes that you set up for the application.
- **About box** is a dialog box that appears when your users select Help, About from the application menu.

You can also select a form template from here. A form template is model of a form that you can customize.

Click Next to get to the last screen and click the Button labeled Finish to instruct Visual Basic to complete your initial application.

### **How To Create A Project From The New Project Window**

The New Project window appears, when you first start Visual Basic or when you select File, New Project. You will always need **toolbars** in your project. Visual Basic has a total of four toolbars:

- **Debug.** This toolbar appears when you use the interactive debugging tools to trace and correct problems.
- **Edit.** This toolbar aids your editing of Visual Basic code.
- **Form Editor.** This toolbar helps you adjust objects on forms.
- **Standard.** This toolbar is the default toolbar that appears beneath the menu bar.

You can display and hide these toolbars from the View, Toolbars menu.

### **Using the Toolbox**

The Toolbox window differs from the toolbar. The toolbox is a collection of tools that act as a repository of **controls** you can place on a form. Figure 5 shows the most common collection of toolbox tools that you'll see.

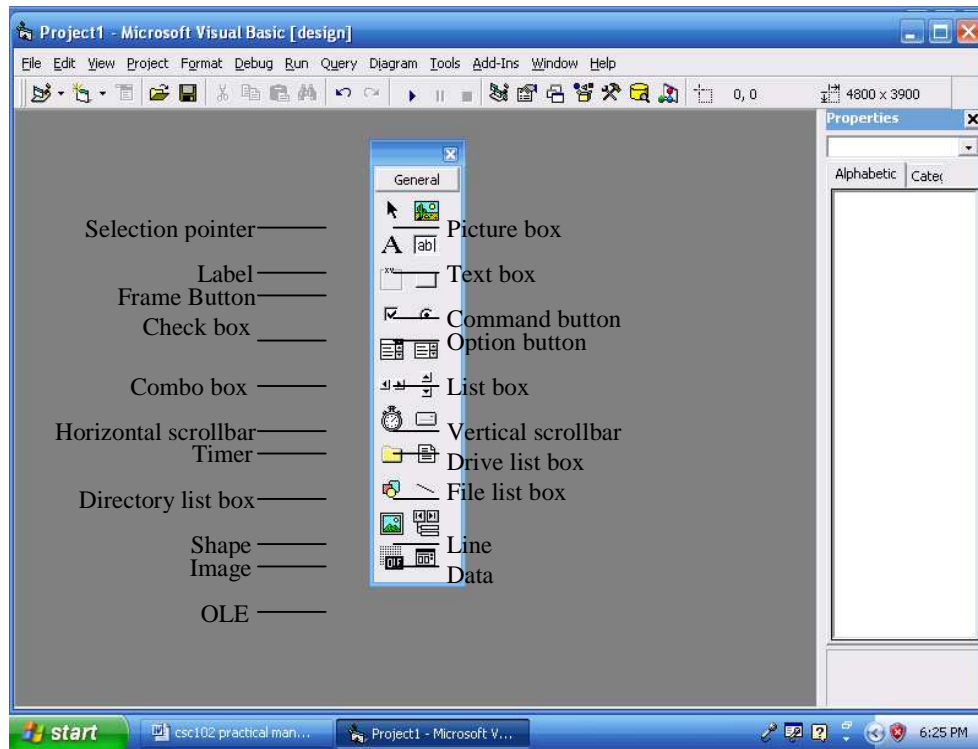

**Figure 5**

### **The Form Window**

Most of your work goes on inside the Form window. You'll design all your application's forms, which are the background windows that your users see, in the central editing area where the Form window appears. You can resize the Form window to make the windows you create in your application as large or small as needed.

An application may contain multiple forms: you can display one or more of those forms in their own Form window editing areas. Activate a form by clicking a form by clicking anywhere within the window or on the title bar.

### **The Form Layout Window**

The Form Layout window is an interesting little window connected closely to the Form window, because the Form Layout window shows you a preview of the Form window's location.

## **4.0 Conclusion**

Visual Basic programming language is one of the most popular application programming languages which is easy to learn. It is event driven and have some attributes of Object Oriented Programming. These attributes has made it one of the most preferred languages in Windows environment.

## **5.0 Summary**

In this unit, we have learnt the following:

- (a) The concept of working with graphical objects and the general Visual Basic Programming concepts.
- (b) How to design a project from the application wizard and,
- (c) How to use the toolbox.

## **6.0 Tutor Marked Assignment**

- a. What is a toolbox in Visual Basic Programming environment?
- b. List and discuss the functions of ten items in Visual Basic toolbox

## **7.0 References and Further Reading**

Akinyokun, O.C, (1999). *Principles and Practice of Computing Technology*.

International Publishers Limited, Ibadan.

Balogun, V.F., Daramola, O.A., Obe, O.O., Ojokoh, B.A., and Oluwadare S.A., (2006).

*Introduction to Computing: A Practical Approach*. Tom-Ray Publications, Akure.

Francis Scheid (1983). *Schaum's Outline Series: Computers and Programming*. Mcgraw-Hill Book Company, Singapore.



## **STUDY UNIT 13: VISUAL BASIC PROJECT WINDOW**

### **Table of Content**

The project Window

The Properties Window

### **1.0 Introduction**

The project window enables the user or programmer to navigate the items created in a project such as the forms and modules. The property window on the other hand helps the programmer to choose the appropriate properties for an object. When you display the Properties window for a control, you can modify its values. You can do that by selecting the view option and then Properties window.

### **2.0 Objectives**

The objective is to enable user gain more mastery of the Visual Basic programming environment.

### **3.0 The project Window**

The Project Window helps you to manage your application's components. It lists its components in a tree-structured listing. Related objects appear together. You can expand or shrink the details by clicking the plus sign next to the object labeled *Forms*, a list of the current project's forms will appear.

The following kinds of objects can appear in the Project window:

- Projects
- Forms
- Modules
- Class modules
- User controls

- User documents
- Property pages

### **3.1 The Properties Window**

A form can hold many controls. As you add controls to a form, you can select a control by clicking the control. When you select a control, the Properties window changes to list every property related to that control. When you add a control to a Visual Basic application, Visual Basic sets the control's initial property values. When you display the Properties window for a control, you can modify its values. You can do that by selecting the view option and then Properties window.

Figure 6 shows a Properties window listing some of the properties for a Label control.

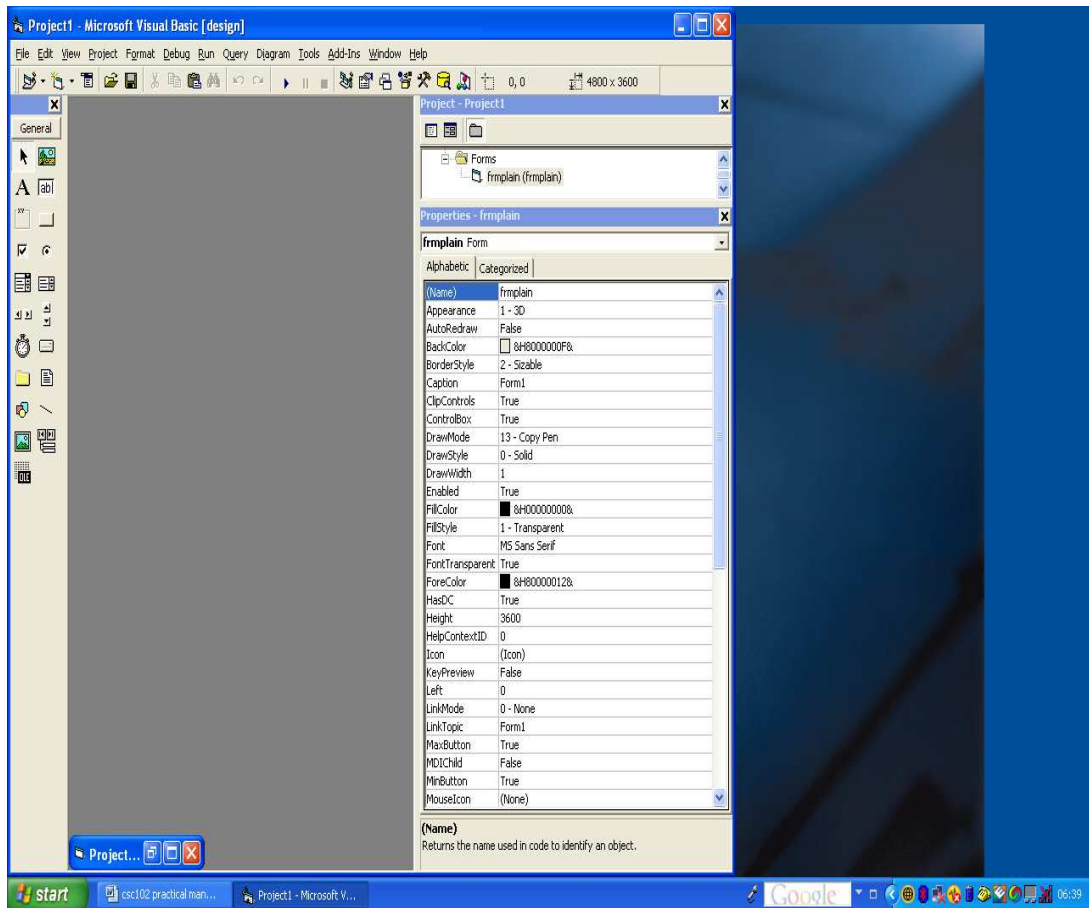

**Figure 6**

### **Example 1**

Create an application with three controls, a label, a command button and an image control to look like what you have in Figure 7.

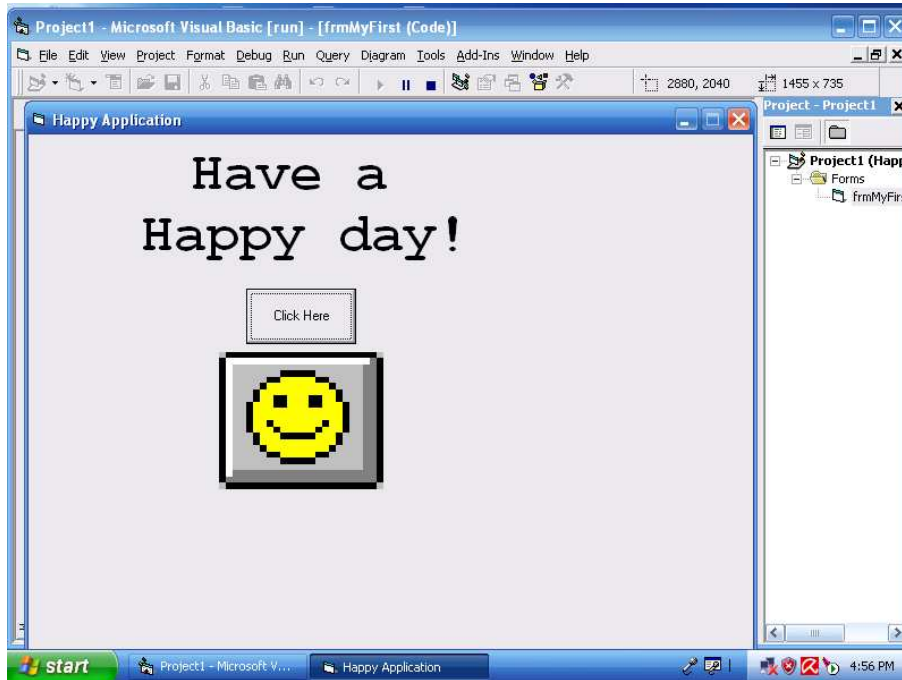

**Figure 7**

**Guide to the solution**

To place a control on a form, click on the control's icon on the toolbox and move the crosshair mouse cursor to the form. As you drag the mouse, Visual Basic draws the control's outline on your form. When you have drawn the control at its proper location and size, release the mouse button to place the control at its proper location.

Assign the following property values to the application's forms and controls:

<b>Control</b>	<b>Property</b>	<b>Property value</b>
Form	Max Button	False
Label	Alignment	Center
Label	Name	LblHappy
Label	Caption	Have a happy day!
Label	Font	Courier New
Label	Font style	Bold

Label	Size	36
Label	Left	1320
Label	Height	1695
Label	Top	120
Label	Width	4695
Image	Name	imgHappy
Image	Stretch	True
Command button	Name	cmdHappy
Command button	Caption	Click Here

While writing your application, you can run the application to see what you have done by pressing F5.

You need to add some codes to finalize the application. Double click the form somewhere on the grid inside the Form window to display the code window. Add the codes shown in Figure 8.

To return to the Form window, click the Project window's View Object button.

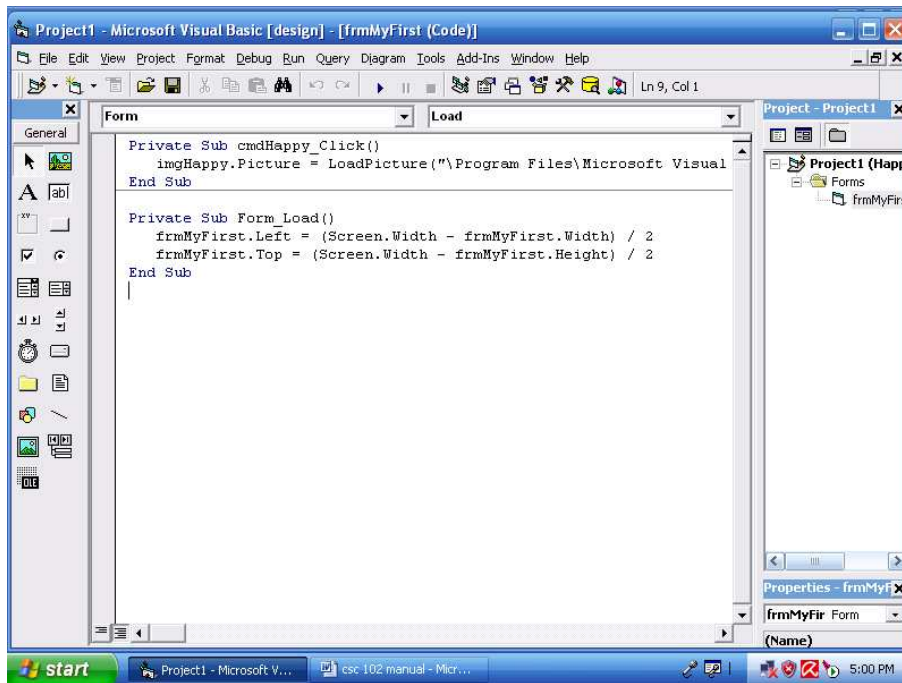
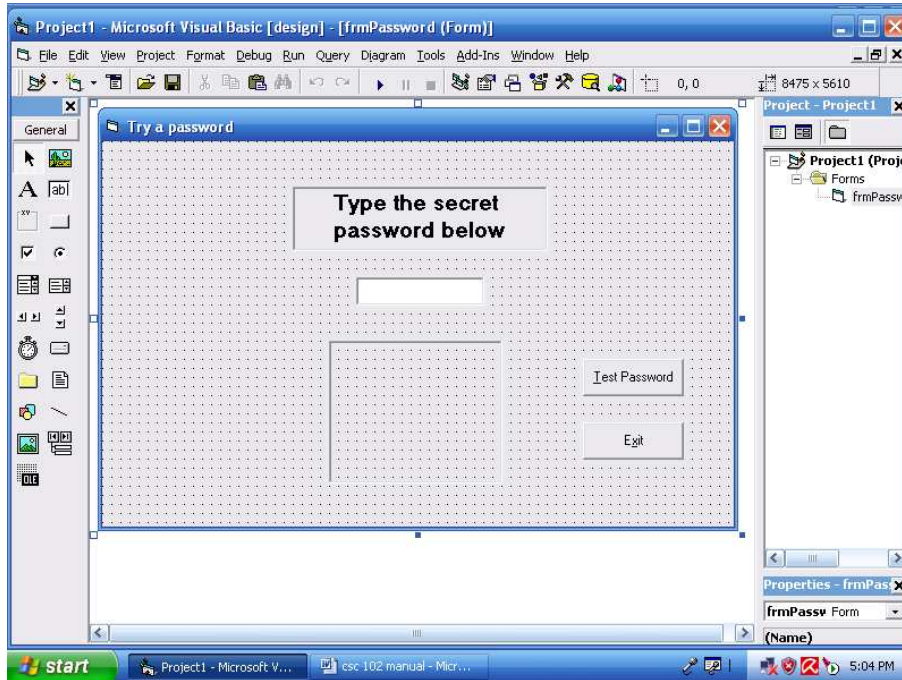

**Figure 8**

Run your program and click the command button. An image like that shown in Figure 7 appears. Save your project and click the Close window to terminate the program. To save, Select File, Save Project. The Save Project option saves every file inside your project as well as a project description file with the filename extension. VBP. Visual Basic asks first for the filename you want to assign to your form. Visual Basic then asks first for a project for the project description file. Answer No if Visual Basic asks to add the project to the Source Safe library.

### **Example 2**

Create an application to look like what is shown in Figure 9, to include a label, a textbox (where the secret characters will be entered), an image, and two command buttons.



**Figure 9**

**Guide to the solution**

Set these controls and properties on the form:

<b>Control Property Name</b>	<b>Property Value</b>
Form Name	frmPassword
Form Caption	Try a password
Form Height	5610
Form Width	8475
Image Name	imgPassword
Image Border Style	1-Fixed Single
Image Height	1890
Image Left	3000
Image Stretch	True
Image Top	2640
Image Width	2295
Label Name	lblPrompt
Label Border Style	1-Fixed Single
Label Caption	Type the secret password below
Label Font	MS Sans Serif
Label Font Size	14
Label Font Style	Bold
Label Height	855
Label Left	2520
Label Top	600
Label Width	3375
Text box Name	txtPassword

Text box Height	375
Text box Left	3360
Text box PasswordChar	*
Text box Text	(Leave blank by clearing the default value)
Text box Top	1600
Text box Width	1695
Command button Name	cmdTest
Command button Caption	&Test Password
Command button Left	6360
Command button Top	3000
Command button #2Name	cmdExit
Command button #2Caption	E&xit
Command button #2Left	6360
Command button #2Top	3720

Add the following code seen on the screen in Figure 10 to activate the password-based form:

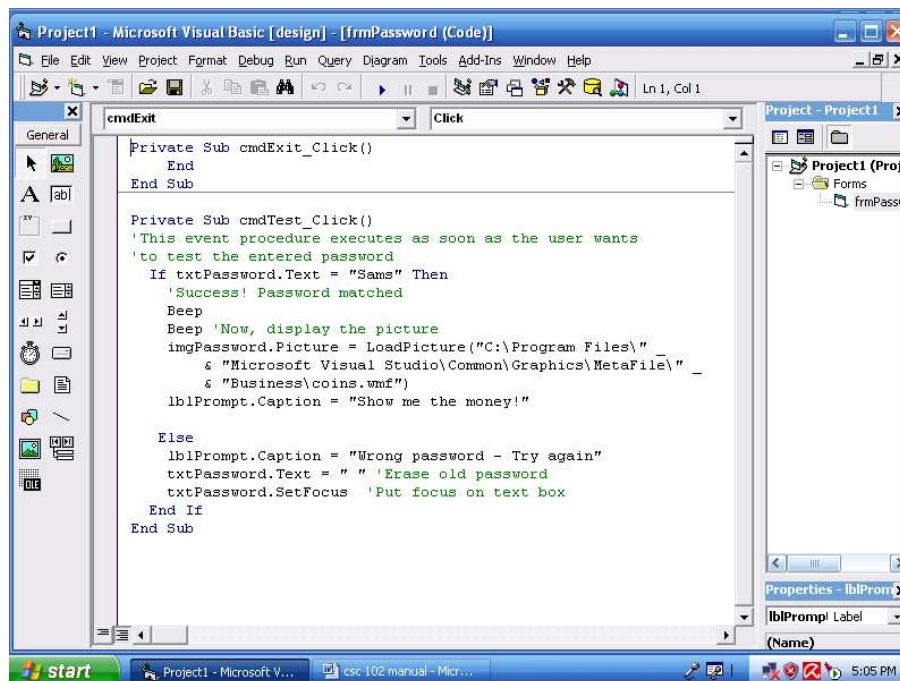
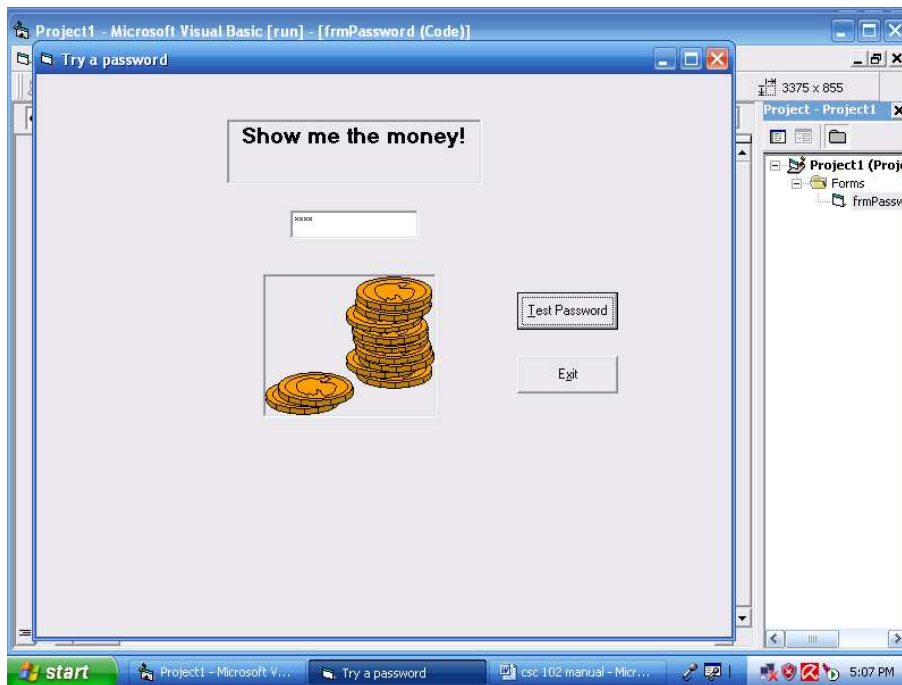

Figure 10



After running the application, you have what is shown in figure 11 below:



**Figure 11**

#### **4.0 Conclusion**

The project window and the property window are very important to features of the Visual Basic programming environment that are of immense importance to the programmer.

#### **5.0 Summary**

In this unit we have studied the importance of the project window and the property window.

#### **6.0 Tutor Marked Assignment**

Create an application with three multiline text boxes. Make the text boxes tall enough to display three or four lines of text. Give the first one a vertical scrollbar, the second a horizontal scrollbar, and the third one both kinds of scrollbars. In all the three text boxes, supply the default text "Type here". In addition to the text boxes, include an Exit command button, so the user can press Alt+X to terminate program.

## **7.0 References and Further Reading**

Akinyokun, O.C, (1999). *Principles and Practice of Computing Technology*.

International Publishers Limited, Ibadan.

Balogun, V.F., Daramola, O.A., Obe, O.O., Ojokoh, B.A., and Oluwadare S.A., (2006).

*Introduction to Computing: A Practical Approach*. Tom-Ray Publications, Akure.

Francis Scheid (1983). *Schaum's Outline Series: Computers and Programming*.  
Mcgraw-Hill Book Company, Singapore.

## **STUDY UNIT 14: CREATING MENU APPLICATIONS**

### **Table of Contents**

Creating menu applications

#### **1.0 Introduction**

One of the basic features of the Graphical User Interface (GUI) is that enables user to select the operations to be performed through menus with the aid of the mouse. In this unit students are introduced to the rudiments of creating a menu application.

#### **2.0 Objectives**

The objective of this unit is to enable students learn the steps involved in creating visual basic applications with menu.

#### **3.0 Creating menu applications**

You can generate menus for your applications using the application wizard. After you click the menu options and submenus you want in your applications, the Application wizard generates the appropriate menu controls and places them in the generated application.

The Toolbox window does not contain any menu-creation tools. Instead, Microsoft offers a special menu tool called the Menu Editor, shown in Figure 13 that you use to create menus. From the Form window, you can press Ctrl+E to display the Menu Editor. The Menu Editor helps you design menus for your applications. In a way, the Menu Editor acts like a Properties window for the menu bar because you will designate the names of the menu controls as well as the captions that the users see on the menus and other related information from within the Menu Editor.

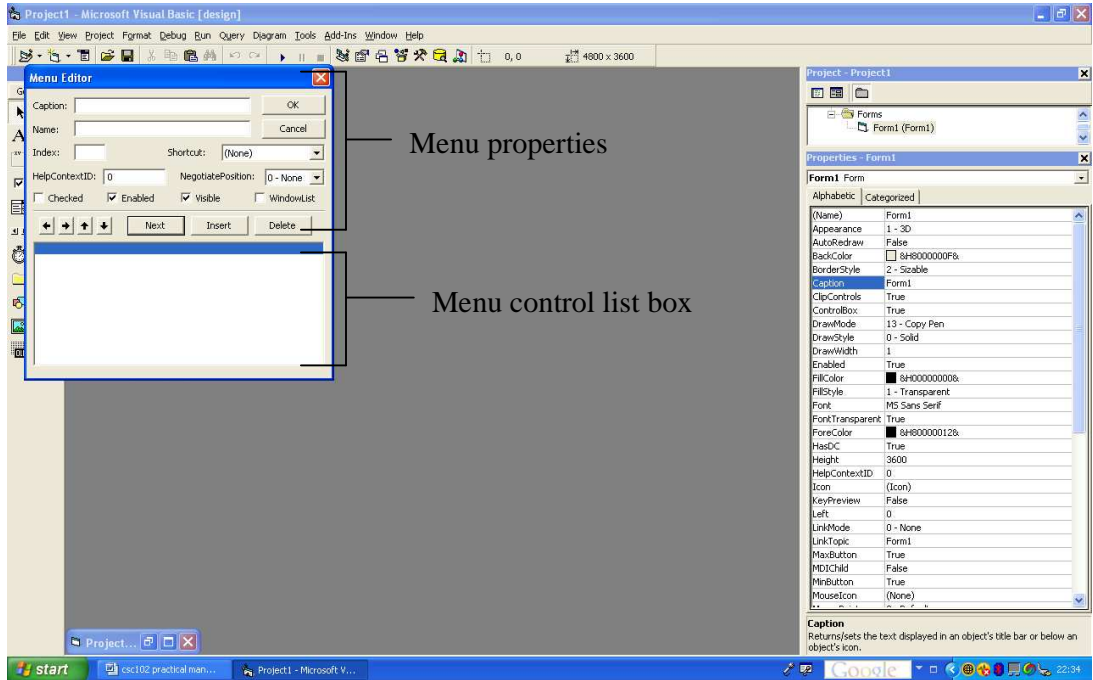

**Figure 1**

A menu bar offers a special kind of control that lets your select options and issue commands.

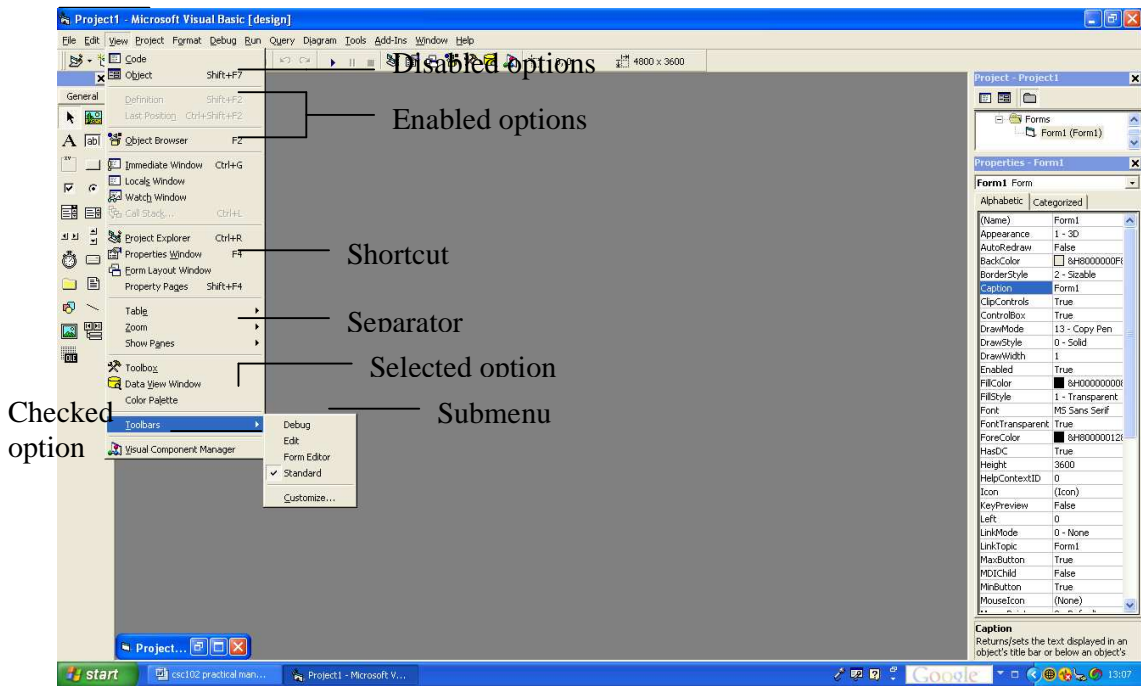

**Figure 2**

Figure 2 displays the menu bar and its parts.

Practice creating of menu applications with the following Exercise 4.

### Example 1

Create an application with three menu options and a label. Your screen should look like what you have in Figure 3.

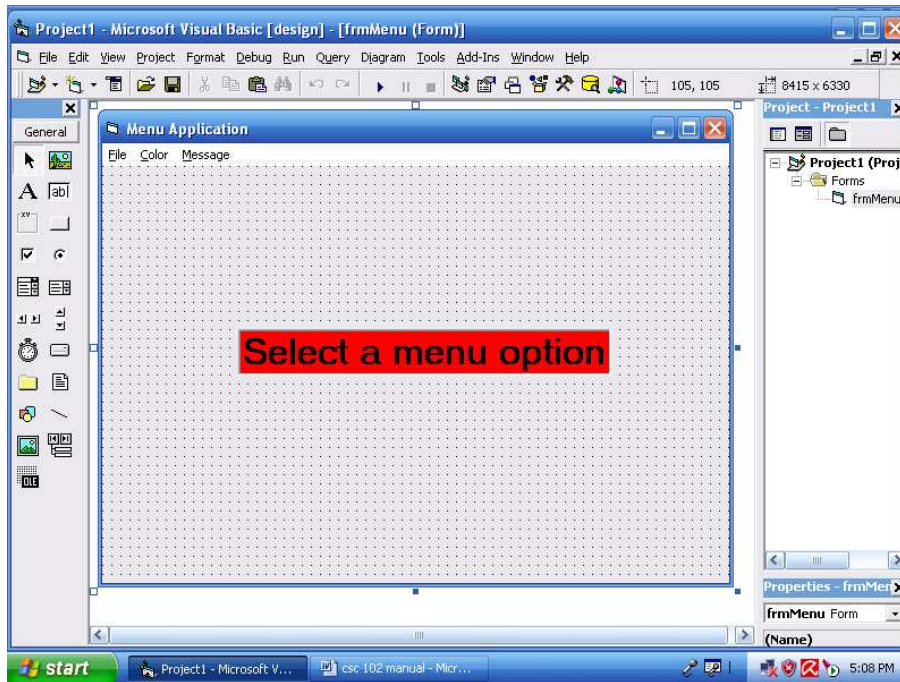

Figure 3

### Guide to solution

To create the menu bar, click the form and press Ctrl+E to display the Menu Editor.

- Type &File for the Caption field. As with all other Visual Basic values, the ampersand indicates that the F will be the accelerator key for the menu selection. As you type the caption, Visual Basic displays the caption in the Menu control list box in the bottom half of the Menu Editor.
- Press Tab to move to the Name field. Tab and Shift+Tab shift the focus between the Menu Editor fields.
- Type *mnuFile* for the name of the first menu option.

- Leave all other fields alone and click the Next button to prepare for the remaining menu bar options. The Next button lets the Menu Editor know that you are through with the first option and want to enter another.
- Type `&Color` for the next menu bar caption and type `mnuColor` for the name.
- Click Next to add the next item.
- Type `&Message` for the third and final menu bar caption and type `mnuMessage` for the caption. Your Menu Editor should look like the one in Figure 2.

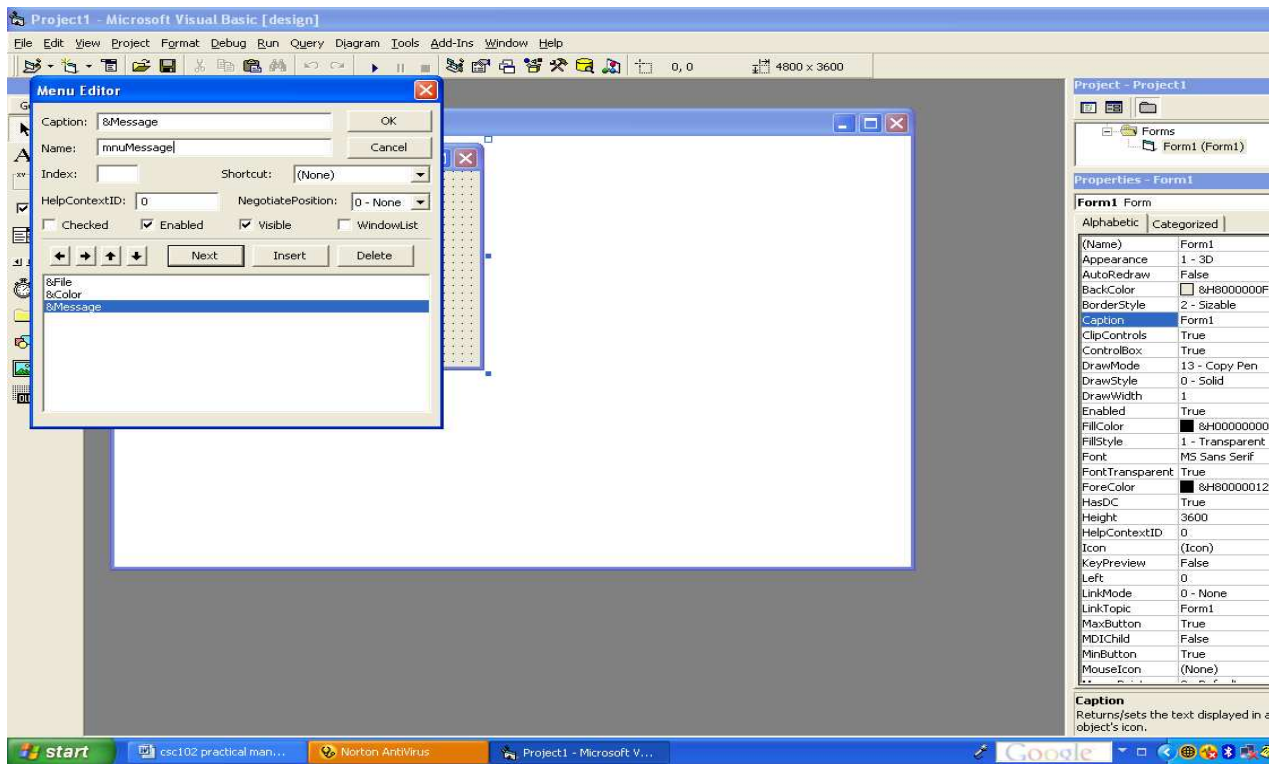

Figure 2.

### 3.2 Adding a Pull-down menu

You can either create pull-down menus as build the menu bar or add the menus later. If you create the complete menu bar first, however as you've done in this exercise, you'll have to insert the menu options in their respective locations when you are ready to add them. The Menu Editor's Insert button lets you do just that.

## Example 2

Add three checked options : Blue, Green, and Red, to the second menu, Color. These colors will be mutually exclusive; the label will not be able to be all three colors at once, but only one color at a time. Such colors make perfect candidates for checked menu options. Your application should like Figure 17 after running. Also, include a submenu to the Message menu. Let it contain the checked messages displayed in Figure 18, and include a separator bar as shown.

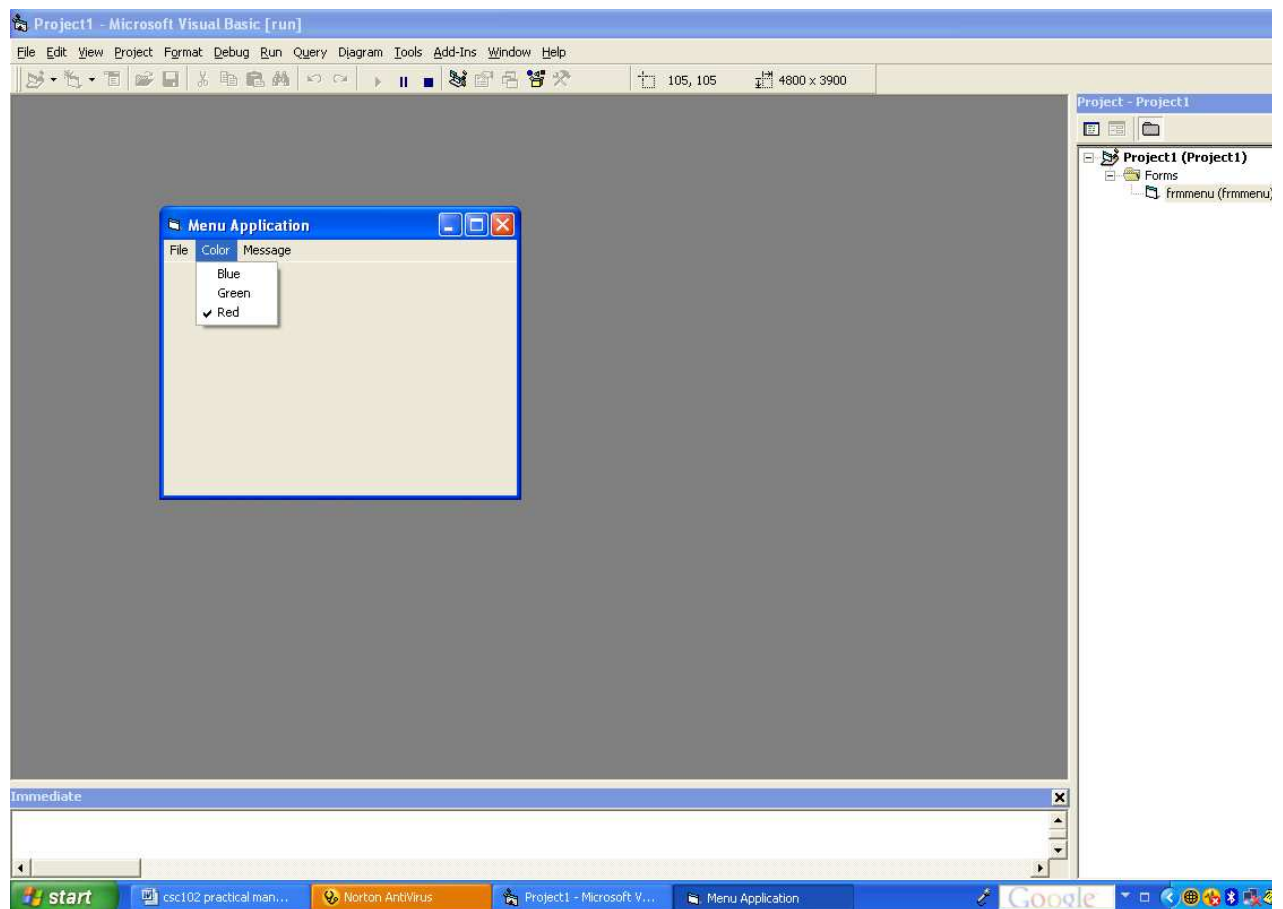
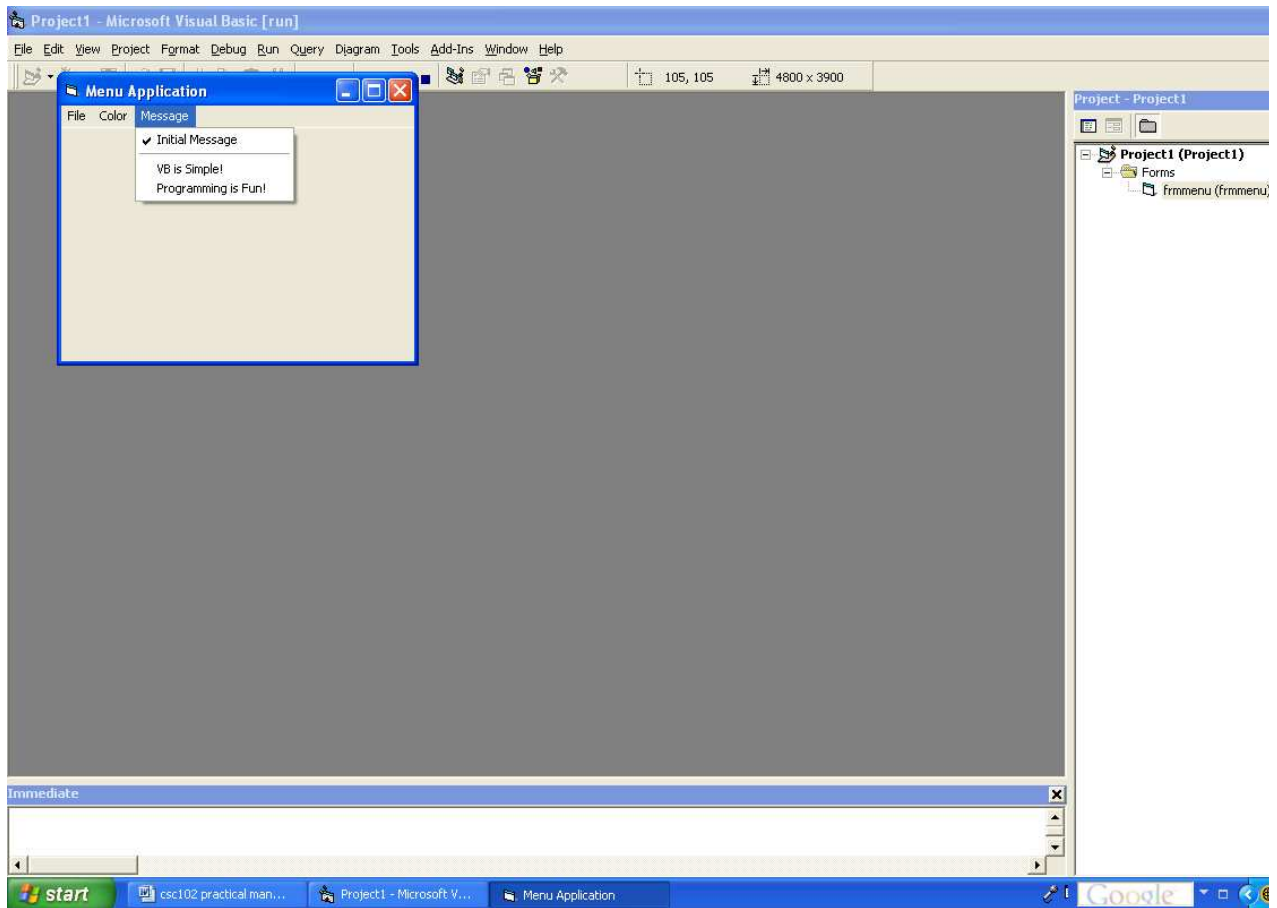

Figure 17



**Figure 3**

Follow these steps to do these:

- Open the Menu Editor
- Click the &Message option in the Menu control list box to highlight that option.
- Click the Insert button and right arrow button three times to add three empty rows for the Color menu options.
- Highlight the first blank row where you'll add the Blue option.
- Type &Blue for the caption and mnuColorBlue in the Name field. When the user first runs the program, the Blue option will be unchecked to indicate that Blue is not currently selected.
- Click Next to enter the next option.



- Type &Green for the caption and mnuColorGreen in the Name field of the next option.
- Click Next to enter the next option.
- Type &Red for the caption and mnuColorRed for the name of the next option.
- The Red option is to be checked when the user first starts the program. Therefore, click the Checked field to place the check mark next to Red.
- Close the Menu Editor and run your application.
- To add the Message menu, display the Menu Editor and click the row beneath &Message in the lower half of the Menu Editor to prepare the Menu editor to receive the next option.
- Follow the steps as for the Color menu.
- To create the separator bar, after entering the first item, click next and type a single hyphen(-) for the caption (all separator bars have this caption). Type mnuMessageSep1 as the separator bar's name.
- Fix the other options appropriately and run the application.

To finalize the menu with code:

Open the code window and type the code shown in Figures 19 and 20. The code controls the label's colour and contents.

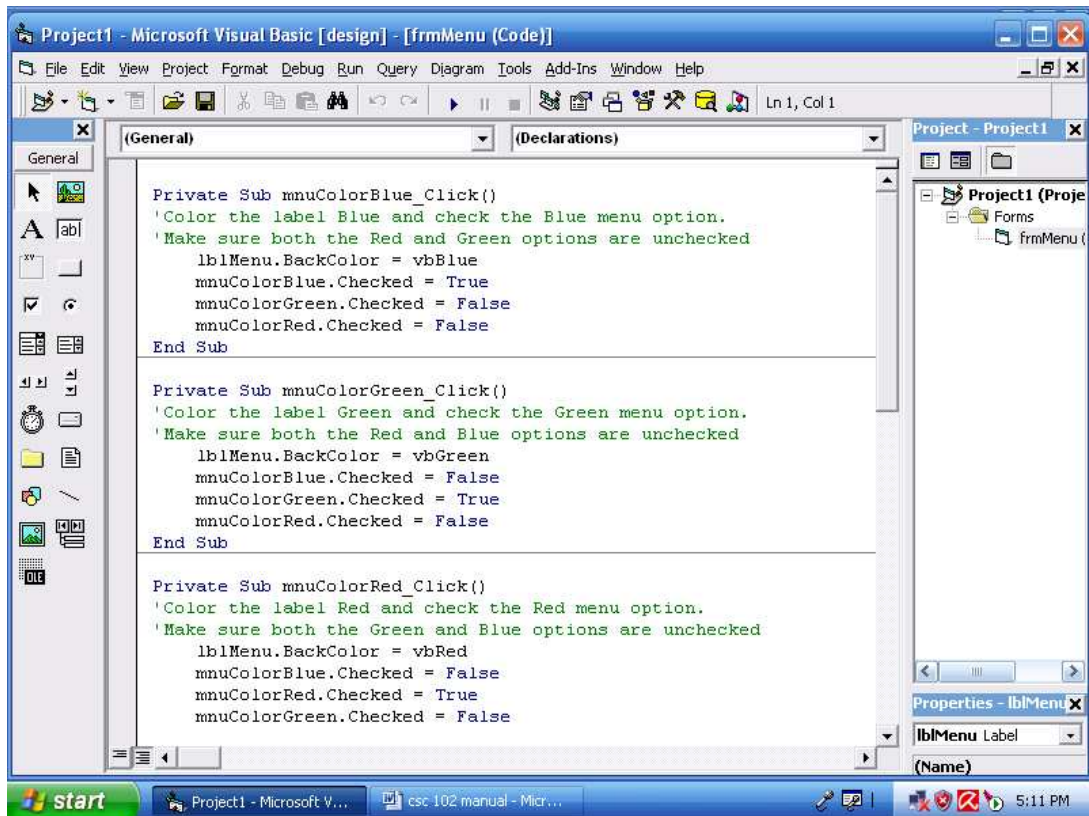

Figure 4

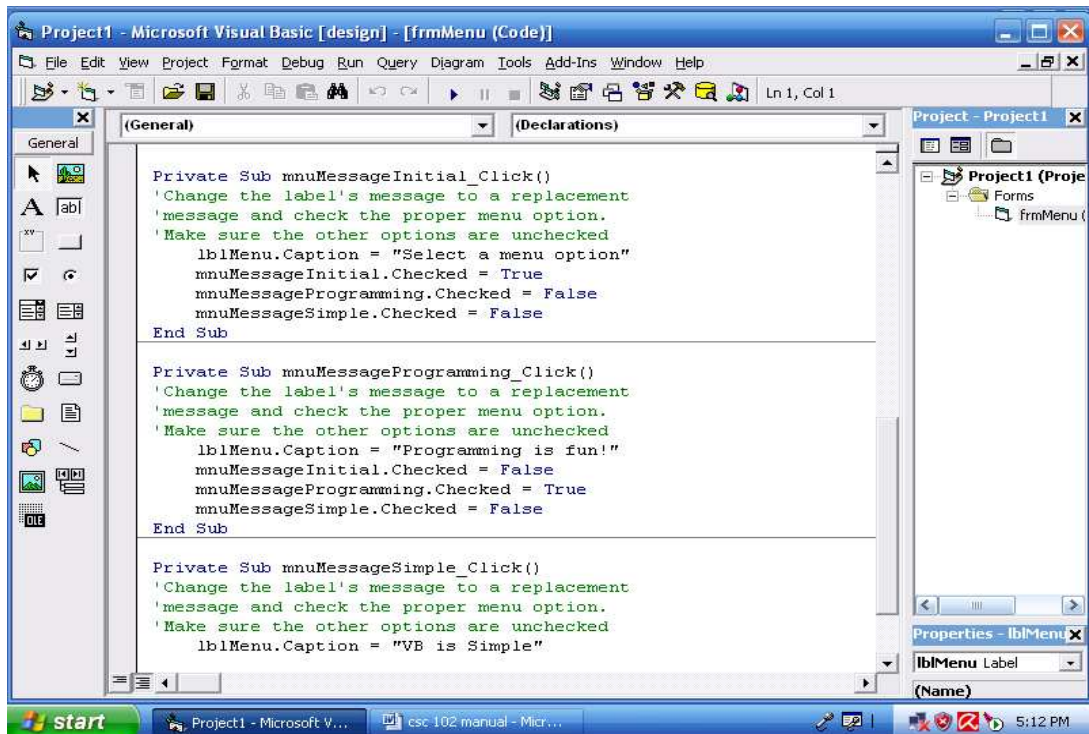

Figure 5

When the application is run, the screens look that those in Figures 4 and 5. For Figure 4, colour blue was selected with the second message “VB is Simple”.

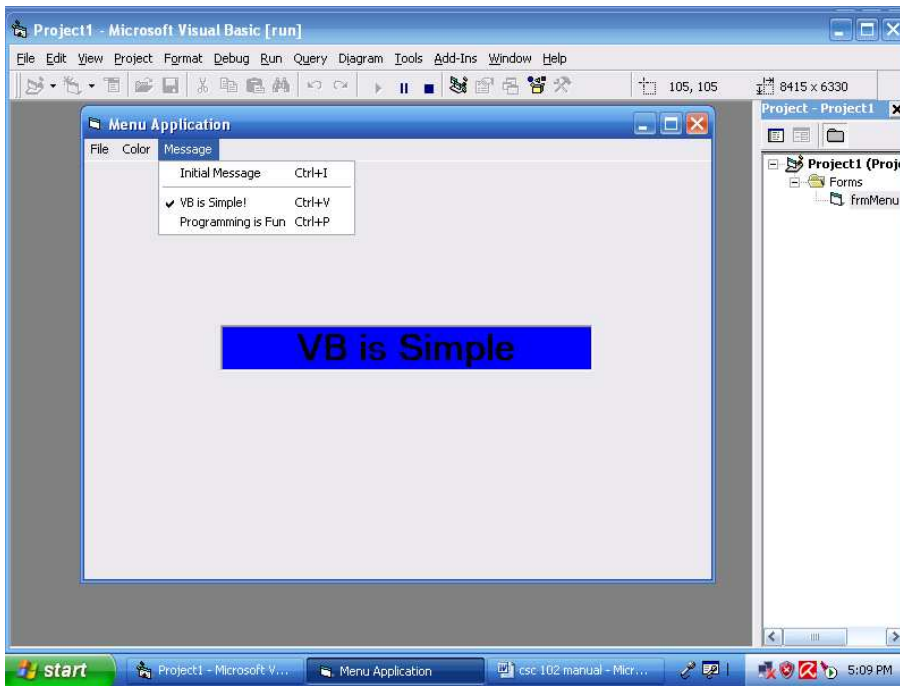

Figure 4

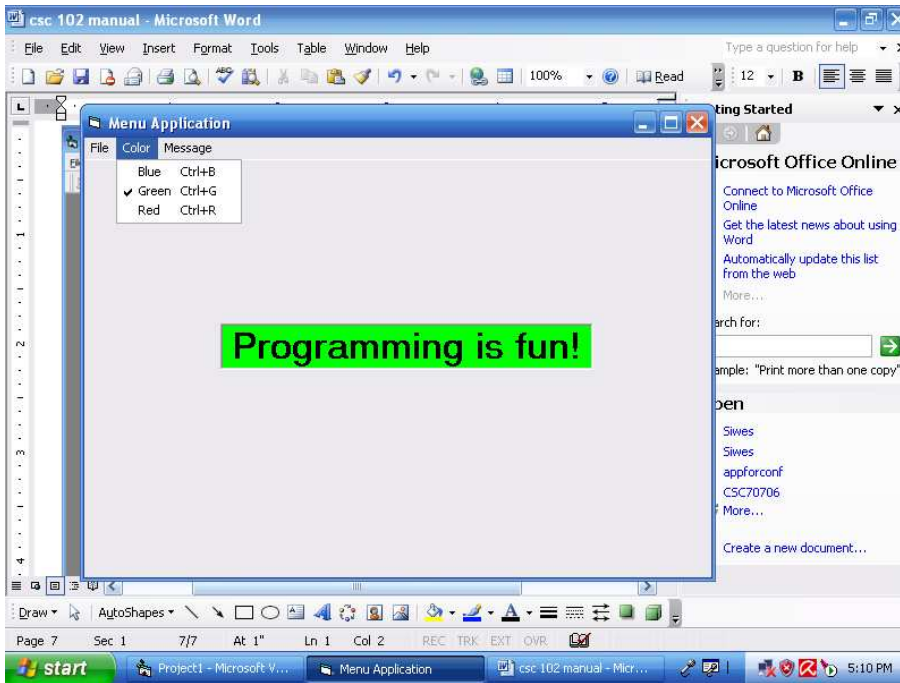

Figure 5

#### **4.0 Conclusion**

Menus make programs interactive and enable programs to be written in modules.

#### **5.0 Summary**

In this unit we have learnt how to create a menu application.

#### **6.0 Tutor Marked Assignment**

Enumerate the steps involved in creating a menu application.

#### **7.0 References and Further Reading**

Akinyokun, O.C, (1999). *Principles and Practice of Computing Technology*.

International Publishers Limited, Ibadan.

Balogun, V.F., Daramola, O.A., Obe, O.O., Ojokoh, B.A., and Oluwadare S.A., (2006).

*Introduction to Computing: A Practical Approach*. Tom-Ray Publications, Akure.

Francis Scheid (1983). *Schaum's Outline Series: Computers and Programming*.  
Mcgraw-Hill Book Company, Singapore.

## **STUDY UNIT 15: ANALYSING VISUAL BASIC DATA**

### **Table of Content**

Visual Basic Code Window

#### **1.0 Introduction**

Here, Students will learn more about the Code window, and practice their programming skills on declaration of data, use of variables of different data types and use of operators.

#### **2.0 Objectives**

The objective of this unit is to enable students learn more about the code window and gain mastery of how to operate in the code window.

#### **3.0 Analysing Visual Basic Data**

##### **Working inside the Code Window**

The Code window contains several sections which include:

- The Declarations section
- General-purpose procedures
- Event procedures

Figure 1 shows the declarations sections in the first set of codes. After the first wrapper line, there is an event procedure followed by another one. General-purpose procedures can be meant to perform any kind of function like computing some data, while event procedures will be executed after the clicking of a mouse once or twice, the loading of a form, or any other event.

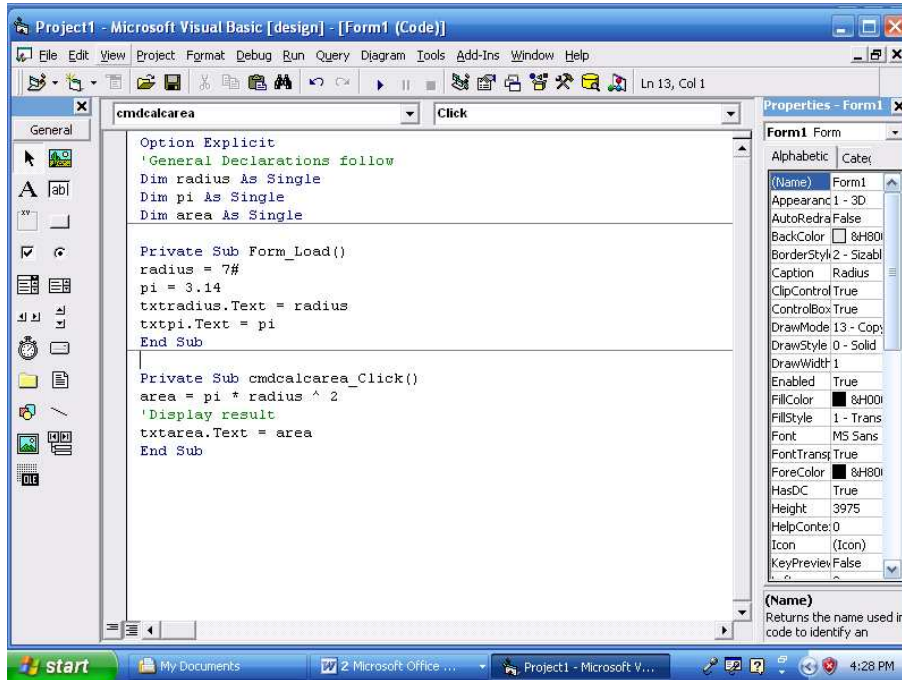

Figure 1

The output of the code displayed in Figure 23 is shown in Figure 24.

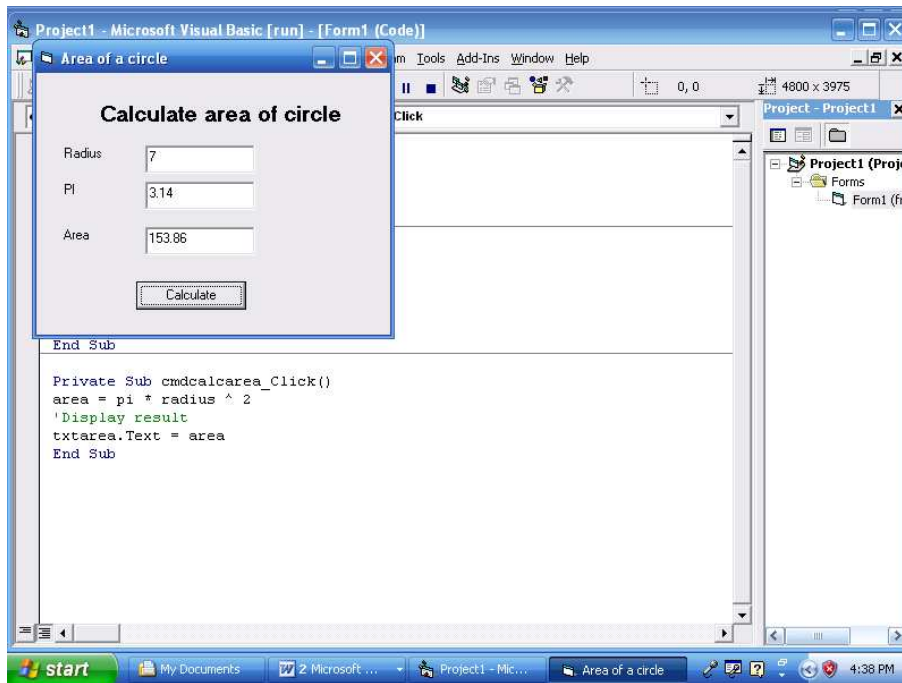

Figure 2

More of use of variables together with the control of programs with conditional operators, logical operators and FOR DO loops are described in the Exercises below:

### Example 1

Write and Run a Visual Basic Program to solve the Quadratic Equation Problem,  $ax^2+bx+c$ .

### Solution

The code that provides the solution to the problem using the IF- THEN statement are shown in Figures 3 and 4. This contains statements explaining most of the basic concepts a beginning VB Programmer needs to know. The output of the program is displayed in Figure 5. As it can be seen, key words are in blue, comments are in green while the other codes are in black.

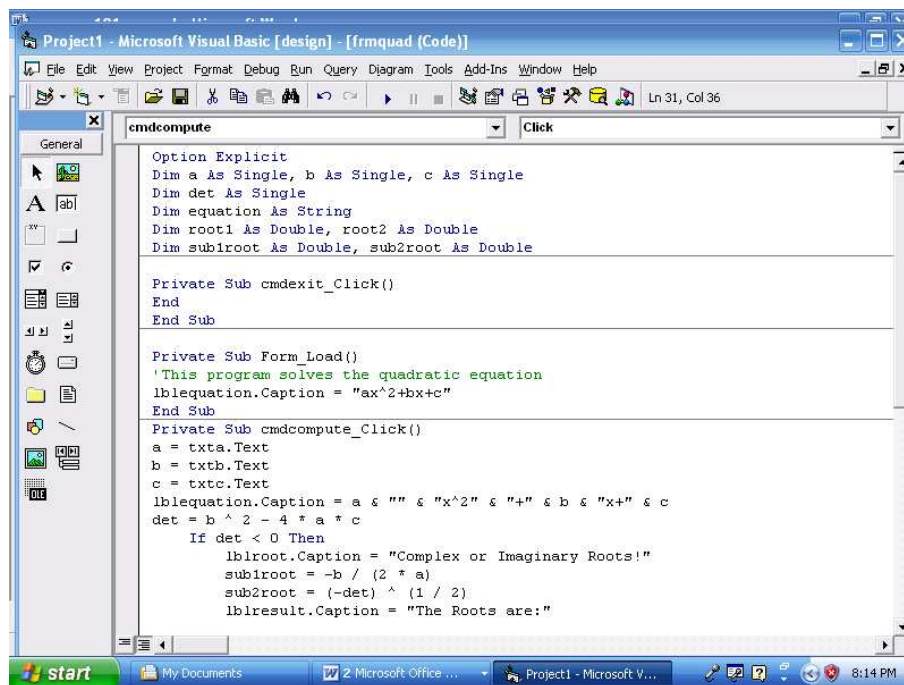

```
Project1 - Microsoft Visual Basic [design] - [frmquad (Code)]
File Edit View Project Format Debug Run Query Diagram Tools Add-Ins Window Help
Ln 31, Col 36

cmdcompute Click

Option Explicit
Dim a As Single, b As Single, c As Single
Dim det As Single
Dim equation As String
Dim root1 As Double, root2 As Double
Dim subroot As Double, sub2root As Double

Private Sub cmdexit_Click()
End
End Sub

Private Sub Form_Load()
'This program solves the quadratic equation
lblEquation.Caption = "ax^2+bx+c"
End Sub

Private Sub cmdcompute_Click()
a = txta.Text
b = txtb.Text
c = txtc.Text
lblEquation.Caption = a & " " & "x^2" & "+" & b & "x+" & c
det = b ^ 2 - 4 * a * c
If det < 0 Then
    lblroot.Caption = "Complex or Imaginary Roots!"
    subroot = -b / (2 * a)
    sub2root = (-det) ^ (1 / 2)
    lblresult.Caption = "The Roots are:"
```

Figure 3

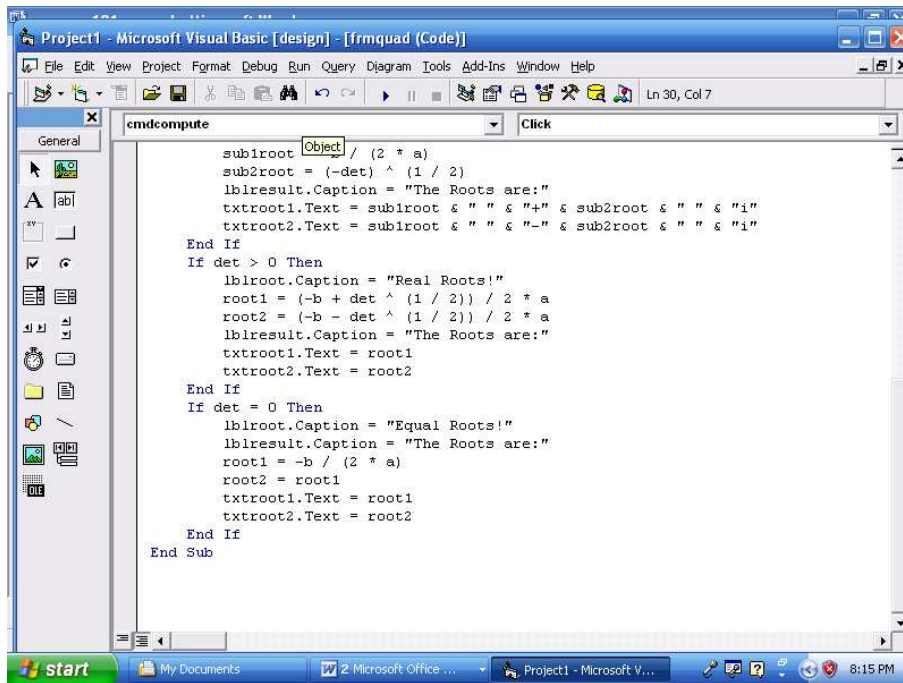

Figure 4

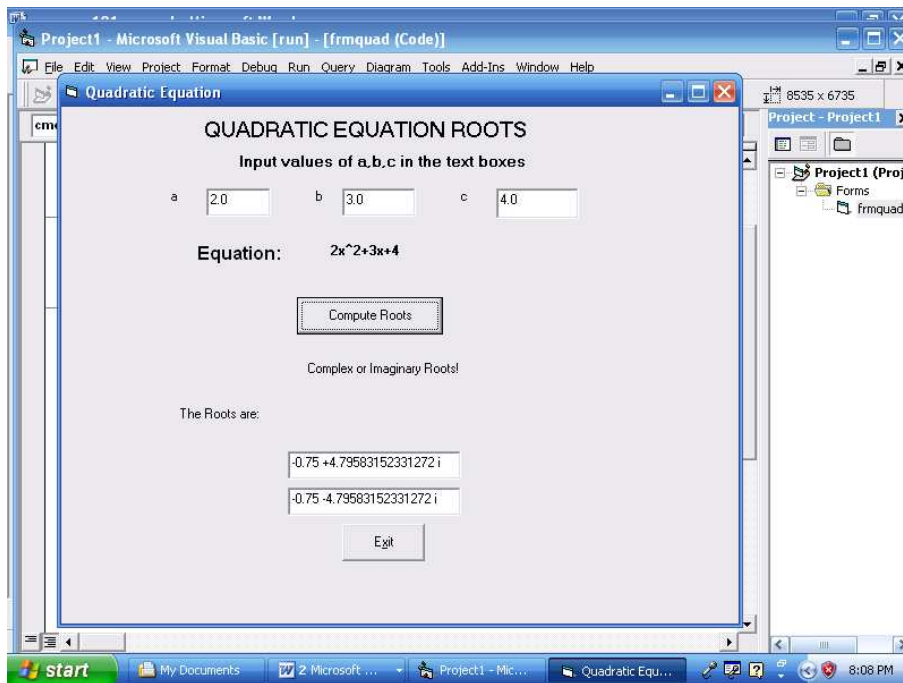
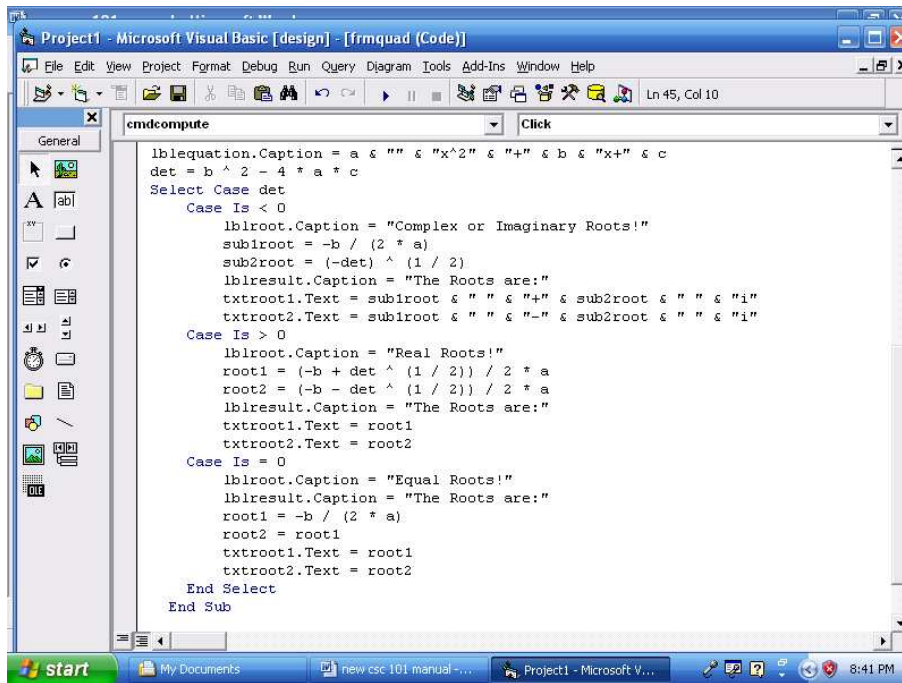

Figure 5

Solving the same problem using SELECT CASE statement, we have the codes displayed in Figure 6.





**Figure 6**

**Example 2**

Write and Run a Visual Basic Payroll Program for 10 employees of a company. The Gross pay sums the Basic pay, Housing allowance and Professional allowance (where applicable). Workers' Grade levels range from 1 to 16. Housing allowance of workers is 30% of Basic pay for workers on levels 8-16 and 40% for levels 1-7 workers. Transport allowance is 20% of Basic pay for all workers. Hazard allowance is 15% of Basic pay for only levels 8-16 workers. The Net pay, which is the take home pay, is the Gross pay – Tax (10% of Gross pay). Design a form through which each worker's data can be entered (to look like the one displayed in Figure 7)

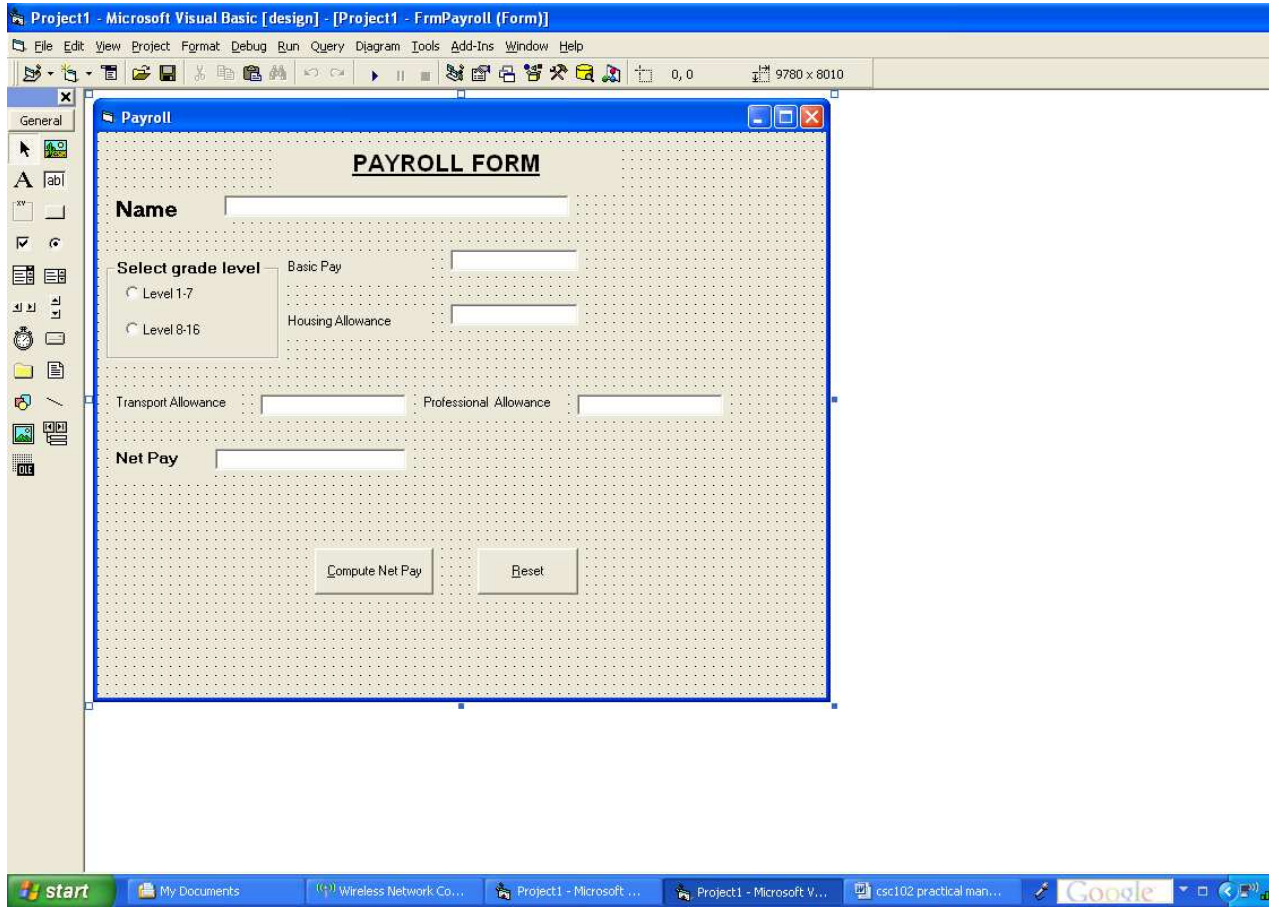
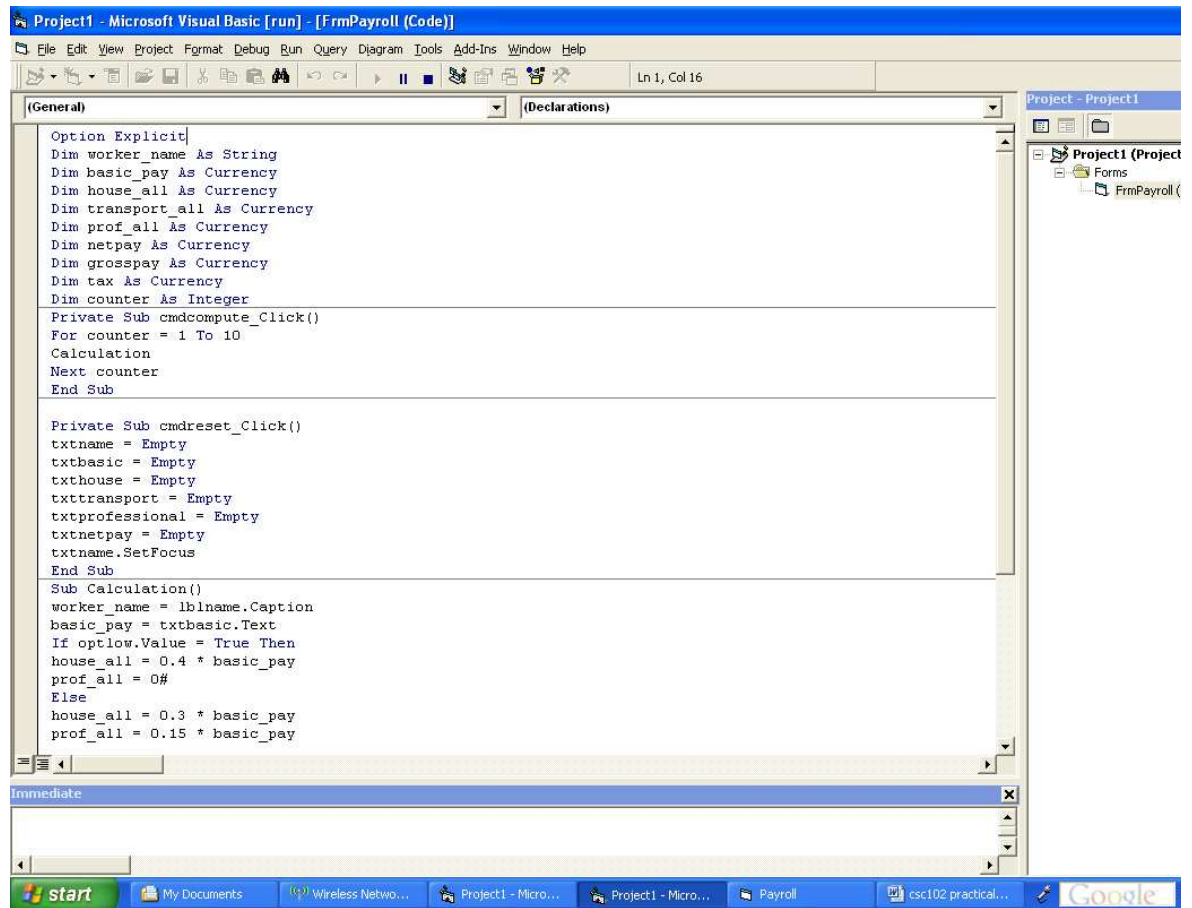
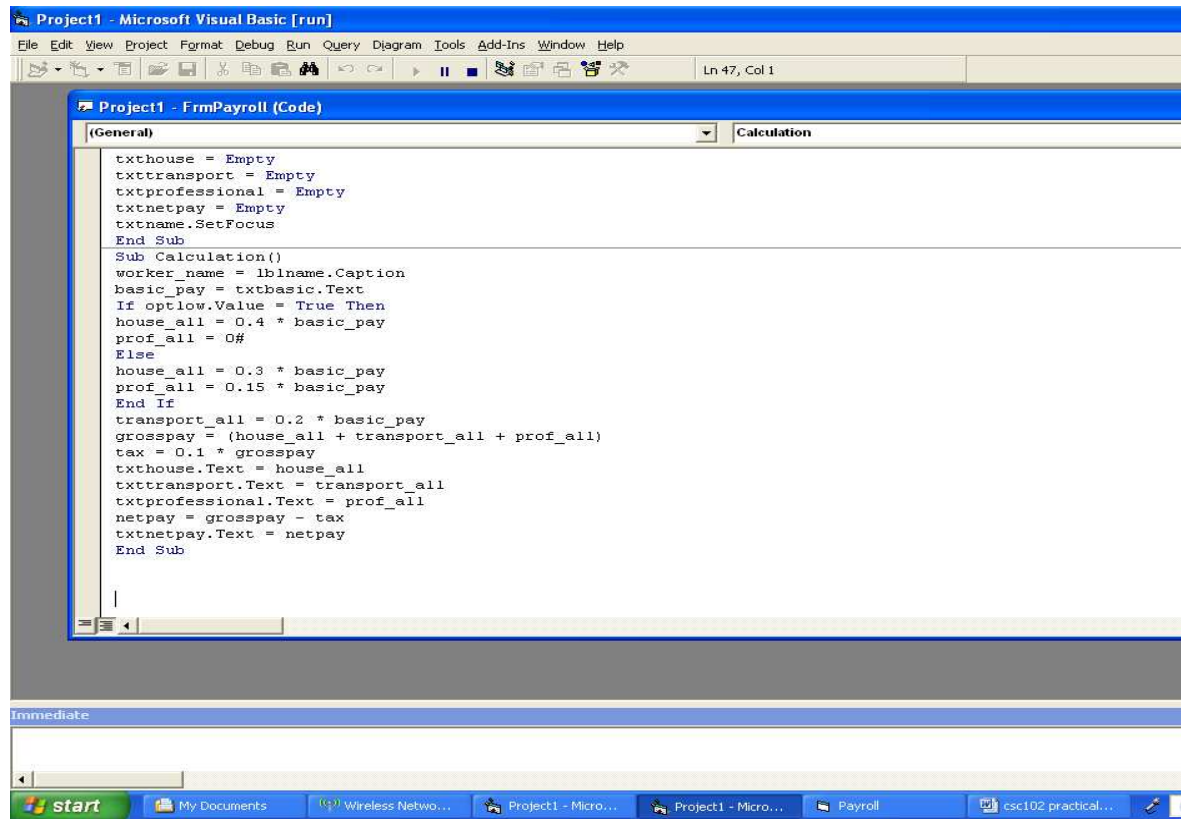

Figure 7



**Figure 8**

Figures 9 and 10 display the code.



**Figure 31**

#### **4.0 Conclusion**

The code window is very important to visual basic programming. Ability to write good programs depends to a large extent on its mastery.

#### **5.0 Summary**

In this unit we have learnt how to program in the code window.:

#### **6.0 Tutor Marked Assignment**

Using the code window, write a program to display the current time.

#### **7.0 References and Further Reading**

- Akinyokun, O.C, (1999). *Principles and Practice of Computing Technology*. International Publishers Limited, Ibadan.
- Balogun, V.F., Daramola, O.A., Obe, O.O., Ojokoh, B.A., and Oluwadare S.A., (2006). *Introduction to Computing: A Practical Approach*. Tom-Ray Publications, Akure.
- Francis Scheid (1983). *Schaum's Outline Series: Computers and Programming*. Mcgraw-Hill Book Company, Singapore.

## **MODULE 6: AREAS OF APPLICATION OF COMPUTERS**

In this module we shall discuss the application of computers in the following areas:

- Education
- Science and Engineering
- Health Care
- Business and Industry
- Transport and Communications
- Recreation
- Government
- The Military etc.

### **STUDY UNIT 16: APPLICATION OF COMPUTERS IN EDUCATION**

#### **Table of Contents**

Application of computer in the field of education.

#### **1.0 Introduction**

Computer has become a universal tool of any modern man (or woman). Literacy, today is not defined only in terms of the ability to read and/or write but in addition, it includes the ability to use and communicate with the aid of computer. In the education sector, computers are being used to promote teaching and learning.

#### **2.0 Objective**

The main objective of this unit is to identify some areas of application of computer in the in the field of education.

### **3.0 Application of Computers in Education**

The field of education provides the most fascinating application of computing system. This has consequently attracted considerable attention from educationist and policy makers since the late 1960s, when computers were introduced into the classroom. The entry of the computer into the classroom has now offered opportunities and possibilities for students to develop their potentials with computer-aided instructions packages. A considerable number of fascinating and entertaining educational computer software packages are now available in almost every subject. These self-tutor instruction packages are well designed to enable the user to learn on his or her own time, speed and convenience. The role of the teacher here is that of a guide so that the student can think more logically and can gain meaningful experience in such structured situations, role playing and other well programmed exercise so that the student can have a better understanding of the interrelationships of variables to real life situations.

Apart from the use of computer as an instructional aid, it is also used in the execution of routine and administrative tasks such as the keeping of academic and administrative records on admissions, examinations, staffing and other routine functions.

The computer has also revolutionized the services rendered by libraries to readers. A computer based on-line public access catalogue system manages a search for materials using indices such as author's name, book title, subject and classmark. Readers using public terminals can go through a menu-driven programme to find specific books or periodicals, recall books on loans and also make requisition for short loan items.

Furthermore, optical character reading devices are used to scan the bar codes on readers library cards to offer a computer based issuing of books to readers. A computer based security system is used to maintain security services in libraries as well. In educational institutions such as nursery schools, primary schools, secondary schools, polytechnics, colleges of education and universities, computer can be used for the following:

- Computer aided self-tutored application packages.
- Computer instructional aids e.g. digital projectors.
- Microsoft PowerPoint application software for preparing slide shows, speeches, seminars, workshop, lectures etc.
- Computer simulated graded exercises, group work.
- Computer-aided laboratory experiments and investigations.
- Computer-aided software packages for special students e.g. the mentally/physically disable (the blinds, deaf etc), adults, KGs, teenagers etc.
- Distant learning programmes e.g. sandwich programmes, through the Virtual Library Technology.
- Teleconferencing technology.
- Placing and sourcing of educational materials/resources e.g. papers, journals, newsletters, magazines, textbooks, films, on the internet.
- Computerization of Library Services to make cataloguing indexing, retrieval, borrowing, return and other library services easier and faster.
- Keeping the records of students, teachers and teaching facilities.
- Estimating the teachers-student ratio with a view to assessing the adequacy of teaching and learning.
- Estimating the ratio of students to teachers and teachers to teaching facilities with a view to assessing the adequacy of teaching and learning.

- Timely generation of students examination results.
- Automatic generation of lecture and examination time tables.
- Aiding students to learn basic theoretical concepts. There are currently, some computer aided learning software packages and hardware devices that are readily available in the market.

#### **4.0 Conclusion**

Computers have been applied in virtually all fields of human endeavour. This unit presents an overview of some of the key areas of its application. The application of computers in education are discussed in details.

#### **5.0 Summary**

In this unit we have learnt that computer could, among others, be applied in the following fields of human endeavour:

- Education
- Science and Engineering
- Health Care
- Business and Industry
- Transport and Communications
- Recreation
- Government
- The Military

We also learnt in greater details the application of the computer to education.



## **6.0 Tutor Marked Assignment**

You have just been appointed as the principal of a model secondary school. Write a proposal to the school governing council on the areas of application of computers to the operations of the school.

## **7.0 References and Further Reading**

Akinyokun, O.C, (1999). *Principles and Practice of Computing Technology*.

International Publishers Limited, Ibadan.

Balogun, V.F., Daramola, O.A., Obe, O.O., Ojokoh, B.A., and Oluwadare S.A., (2006).

*Introduction to Computing: A Practical Approach*. Tom-Ray Publications, Akure.

Oliver E.C. and Chapman R.J. (1986). *Data Processing*, Seventh Edition. ELBS/DP Publications.

## **STUDY UNIT 17: COMPUTER APPLICATIONS IN THE BUSINESS AND INDUSTRY**

### **Table of Content**

Application of computer in business and industry.

### **1.0 Introduction**

In the early days of computing, computers were originally meant to assist in scientific and engineering applications. Today, computers are widely used to perform wide ranging tasks from routine accounting operations to management decision making. Corporate operations are becoming more complex and competitive thus increasing the need to produce and process more accurate and timely data both in quantity and quality. More accurate, reliable and timely data are needed for corporate planning, policy formulation and decision making

### **2.0 Objectives**

The objective of this unit is to highlight the areas of application of computer in business and industry.

### **3.0 Business and Industry**

. The following areas of application of computer technology in business will be discussed in details:

- (i) Payroll.
- (ii) Inventory Control.
- (iii) Auditing Operations.
- (iv) Personnel Record Keeping.
- (v) Preparation of Customer Utility Bills and Payment Orders.
- (vi) Management Information System.
- (vii) High Quality Production Controls.

- (viii) Point of Sale Service.
- (ix) Financial Market Transactions.
- (x) Publishing Industry.

**(i) Payroll**

Payroll preparation is essentially a repetitive and a routine task which has to be done periodically for every single employee in an organization at particular points in time either weekly, fortnightly or monthly. Payroll preparation is a work schedule which demands speed, accuracy, carefulness and honesty. It involves making references to a number of source documents which by their nature also require constant and periodic updating.

These attributes obviously lend themselves to the use of computers which have the capabilities to meet the challenging demands in payroll preparation. These include the capability of the computer to:

- (a) Handle the enormous amount of information required in payroll preparation.
- (b) Store information and make the information available as at when it is needed.
- (c) Handled repetitive recurring tasks and check on its own work as a way of controlling human errors.
- (d) Provide a much better and reliable procedure for the necessary security checks to monitor and detect fraud and other malpractices.

Computer application in payroll preparation involves a number of procedures which include the following:

- (a) Updating the personal records of employees whenever new appointments, resignations, terminations, dismissals and other changes are made within a period of time.
- (b) Computing wages and salaries for each individual workers based on regular and overtime hours worked.
- (c) Making deductions for income tax and for other payments such as union dues and repayment of loans.
- (d) Preparation of pay advice slips and cheques to employees and banks.
- (e) Updating the master payroll file based on the records received from the personnel department.
- (f) Preparation of summary report and analysis for management.

In addition to payroll preparation, the computer is also used for other routine and repetitive book keeping and accounting operations involving recording, classifying and summarizing accounting data. This may involve preparing and updating ledger and journal accounts, invoicing, accounts receivable and payable. Other operations may also include updating and preparing accounts on sales, purchases and inventory. The computer is also used for the preparation and evaluation of the balance sheet and statements of accounts, preparation of dividends and summary accounts for shareholders and management.

**(ii) Inventory Control**

An equally important business application of the computer is seen in the execution of the important business function involved in maintaining a desirable level of inventory in a business organisation. This is to ensure that working capital is not unduly tied in stocks while at the same time available stocks can meet the demands of continued production

process. In this direction, the computer is used as a tool in updating records of inventory and also in the preparation of forecasts and demand predictions based on economic order quantity analysis and other forecasting techniques.

**(iii) Auditing Operations**

The computer is used as a tool by auditors to report accurately on the transaction register which constitutes the most crucial aspect in the audit trail. With the aid of the computer, it is easier for auditors, in their examination of the accounting records of a business, to trace routine business operations so that variances can be detected and verified accurately using various computer audit packages.

**(iv) Management Information System**

An equally challenging and revolutionary application of the computer in business is the important role the computer-based Management Information System (MIS) is playing in management decision making. The computer is used as a tool for the online storage, retrieval, processing and maintenance of corporate data meant to be shared by all the users' departments.

A management Information System involves a computerized system of data processing procedures which are integrated in an organisation to provide accurate, complete, concise, timely and effective data which management can use at various level of decision making for planning, organizing, directing, controlling and monitoring procedures.

Included in Management Information System to be used for the various decision making procedures are a number of systems comprising.

- (a) Controlling and operational planning support systems to deal with day-to-day decisions involving routine processing and transaction procedures.

- (b) Tactical support systems to deal with short-run and middle level management decisions.
- (c) Strategic support systems to deal with corporate strategic and top level management decisions.

With the aid of these support systems, data can be retrieved and analyzed on a continuous and timely basis to aid management decision making and other management functions about sales, finances, purchases, acquisition of plant and equipment, research, market analysis and so on.

**(v) Personnel Record Keeping**

One of the important functions of the personnel department is to maintain and continually update a master file and other records in the personnel department in an organisation. The computer facilitates the effective keeping of a comprehensive and up-to-date record of each employee by providing a comprehensive database involving names, addresses, ages, qualifications, marital status, salaries, dates of promotion and so on.

By keeping such an up-to-date record, a steady flow of various reports can be prepared at the appropriate time to provide the necessary data to aid management decision making in areas such as appointments, promotions, awards of incremental credits, leave periods, staff training, staff development and so on. Furthermore, management can provide the necessary accurate and up-to-date reports on a timely and continual basis to facilitate payroll preparation and also to satisfy other mandatory data requirements from data users such as governments, trade unions, banks, credit unions and tax collectors.

**(vi) Preparation of Customers Utility Bills**

The routine and periodic preparation of customers utility bills particularly those based on meter readings for such utility services as water, electricity, telephone, gas, demands accuracy and speed in which the computer has proved very effective and efficient. With the aid of the computer, accurate and up-to-date customer's bills can be sent to them periodically and in good time to enable settlement to be made. Computers can be used to generate notices of defaulters. Equally important is the use of the computer to calculate dividend, pension and other periodic payments as and when they become due.

**(vii) High Quality Production Controls**

Another important application of the computer which has proved very beneficial in the world of business is the monitoring of production processes so that high quality products and services are provided to customers. Computer Aided Designs (CAD) devices are used in the design of products while computer monitored quality control procedures are used in production process to detect items that fail to meet the approved quality standards and specifications. Such automated devices are used in car assembly plants, oil refineries, manufacturing of drugs and so on. Computer aided quality control devices are also used to monitor weight, size, quantity, contents and other standard specifications in the course of a manufacturing process.

**(viii) Point of Sale Services**

Check-out points in supermarkets and departmental stores are now highly computerized to detect the prices of items. Magnetic Character Readers are used to scan Universal Product Codes on items to provide fast, efficient and satisfactory services to customers in commercial transaction in retail outlets, departmental stores, libraries and other point of sale service.

**(ix) Financial Market Transactions**

Computer application in the financial market is manifested in its use to monitor financial market operations and to disseminate timely and up-to-date information which are announced daily on the radio, television or consumers magazines. Stock exchange centres are highly computerized to provide accurate and up-to-date prices of stock and shares and also to execute the buying and selling transactions that take place in the markets. The computer has long been used to assess, evaluate and monitor stock market prices. With the aid of the computer, market trends are predicted with accuracy and investors are provided with the appropriate and up-to-date data to enable them make intelligent decisions and also to guide them to manage their portfolios effectively.

Furthermore, the computer is used to calculate the foreign exchange rates of major currencies as well as the prices of major commodities such as gold, crude oil, cocoa, coffee, and other commodities that enter into international trade. Computer is also used to provide accurate and up-to-date information on interest rates, gilts and bonds to reflect market trends. The computer application in business is further seen in its use in discounting bills and bonds and other financial market instruments to their present values. Closely related to this is the use of the computer to carefully monitor the movement of a basket of goods and services which measures the rate of inflation in an economy and which further provides a barometer of the standard of living in a country.

Most banking operations are now highly computerized as a move to provide fast, effective and efficient services to customers. These include the use of Magnetic Ink Character Readers to process cheques and the provision of Magnetic Credit Cards to customers to have access to funds twenty-four hours a day at an unattended automatic teller machines. Customers also use their credit cards to open doors to some banking houses to transact business. There are other Electronic Funds Transfer terminals to



perform automatic financial transactions at check out counters in hotels, stores, airlines, railways and other terminals.

In the banking industry, computer can also be used to:

- (a) Keep the records of customers or clients accounts.
  - (b) Monitor, control and evaluate the transactions of the customers and clients on their accounts.
  - (c) Reconcile accounts and assist in producing cashbook balance.
  - (d) Monitor, control and evaluate the bank or insurance company's revenue and expenditure.
  - (e) Automate the production of statement of accounts and assist in generating the accurate the correct addresses to which the statement of account should be sent.
- (x) Publishing industry**

In the publishing industry, computer is used in the following ways:

- (a) Creative writing
- (b) Typesetting manuscript
- (c) Drawing illustrations.
- (d) Generating the table of contents and the index of a book automatically.
- (e) Generating the page size of a book and cut and paste illustrations automatically.
- (f) Processing images such as the scanning of pictures and recording them automatically in the computer store for future retrieval or printing.
- (g) Verification and validation of spellings.
- (h) Assisting the writer of an article to identify the words that have similar meaning.

#### **4.0 Conclusion**

Computer technology has changed the face of business and industry through its various applications. Information and knowledge replace capital and energy as the primary wealth-creating assets. Information technology transforms the way that business is conducted, and the way the commodities of trade are transformed. Discussions presented in this unit has brought to the fore some of the areas of application of computer in business and industry.

#### **5.0 Summary**

In this unit, the following areas of application of computer technology in business will be were discussed in details:

- (a) Payroll.
- (b) Inventory Control.
- (c) Auditing Operations.
- (d) Personnel Record Keeping.
- (e) Preparation of Customer Utility Bills and Payment Orders.
- (f) Management Information System.
- (g) High Quality Production Controls.
- (h) Point of Sale Service.
- (i) Financial Market Transactions.
- (j) Publishing Industry.

## **6.0 Tutor Marked Assignment**

The banking industry in Nigeria has benefited immensely from computer and Information Technology. Briefly discuss the various applications of computer technology to Nigeria's banking industry.

## **7.0 References and Further Reading**

Akinyokun, O.C, (1999). *Principles and Practice of Computing Technology*.

International Publishers Limited, Ibadan.

Balogun, V.F., Daramola, O.A., Obe, O.O., Ojokoh, B.A., and Oluwadare S.A., (2006).

*Introduction to Computing: A Practical Approach*. Tom-Ray Publications, Akure.

Oliver E.C. and Chapman R.J. (1986). *Data Processing*, Seventh Edition. ELBS/DP Publications.

Tunji and Dokun (1993). *Data Processing, Principles and Concepts*. Informatics Books, Lagos.

Richard H. Austing and Lillian Cassel (1986). *Computers in Focus*. Books/Cole Publication Company. Monterey, California

**STUDY UNIT 18: COMPUTER APPLICATIONS IN GOVERNMENT, SCIENCE,  
ENGINEERING, TRANSPORT, COMMUNICATIONS,  
RECREATION AND THE MILITARY**

**Table of contents**

Application of computers in :

- (a) Science and Engineering
- (b) Health Care
- (c) Transport and Communications
- (d) Recreation
- (e) Government
- (f) The Military

**1.0 Introduction**

This unit discusses in greater details the application of computers in the following fields: science and engineering, health care, transport and communication, recreation, government and the military.

**2.0 Objectives**

The objective of this unit is to further introduce students to the application of computers in more areas of the society.

**3.0 Science and Engineering**

Computer is commonly used to find the accurate solutions to both scientific and engineering problems. Weather forecasting has now become a daily activity to which the computer has proved very useful in providing information on the kind of weather we are likely to expect over a period of time. Such accurate predictions help the farmers, airline

operators, navigators and other activities which depend on the weather for their operations. Computer aided critical path study is used to monitor the optimum and efficient use to time, money, material and human resource in the execution and implementation of projects. Such critical path study is used successfully on various projects, for example, the construction of roads, bridges, buildings, manufacturing, the conduct of election and sales campaigns.

Another scientific application of the computer is the monitoring, simulation modeling techniques to provide indicators as to how systems such as the human body, economy, weather, demographic variables and so on react to changes in situations. The application of simulation techniques helps in taking decision and precautions in advance should in case such repercussions happen when the desired changes are introduced in practical situations. Computers are also to design buildings, roads, bridges, vehicles, aero planes, ships and complex architectural, ships and complex works and so on. Prototyping is increasingly being used to minimize the financial commitment to the real life construction of these systems.

The computer is used to find solution to very complex mathematical and statistical computations at incredible speed and accuracy. Furthermore, various software packages are now increasingly being developed to analyse surveyed data, construct life tables, perform mortality demographic and other multivariate data analysis designed to revolutionize scientific research and to find practical solutions to complex, challenging and everyday life situations. We now outline the use of computer in the following specific areas among others.

**(i) Research Institutions**

- (a) Evaluating, monitoring and controlling laboratory experiments.
- (b) Storing the readings obtained in laboratory experiments.
- (c) Standardizing the reading obtained in laboratory experiments.
- (d) Tabulating or plotting the graph of the results obtained from laboratory experiments.
- (e) Interpreting the results obtained from laboratory experiments.
- (f) Modeling and simulating systems.
- (g) Developing the prototypes of systems.

**(ii) Engineering and Architecture**

- (a) Designing and drawing with very high precision, accuracy and at minimum cost.
- (b) Modeling and simulating the behaviour of engineering or architectural systems.
- (c) Developing the prototype of say, an aircraft, a motor car, assembly plant and so on. It is possible to test and monitor the performance of these systems without serious financial commitments.
- (d) Fabricating, constructing and assembling the component parts of machines such as motor car, aircraft and engineering plants without any hazards.

**3.1 Marketing Department**

- (a) Comparative analysis of products of two or more companies with a view to predicting some areas of improvement.
- (b) Market survey, statistical analysis of proportional market gains and prediction of new market areas.
- (c) Creation of the awareness and appreciation of products.

### **3.2 Agriculture**

- (a) Keep records of soil, rainfall, weather conditions, land size, crops, chemicals and ultimately process the records to estimate the soil fertility and yield per hectare over a number of years.
- (b) Keep records, of poultry and animal husbandry farm with a view to estimating the feed mix, environmental condition desirable for optimal yield.
- (c) Assess the behaviour patterns of farmers in a cooperative venture and assist in matching the farmers that have identical behaviour with a view to optimizing their productivity.

### **3.3 Law and Justice**

- (a) Modeling and simulating legislative procedures.
- (b) Indexing, storage and retrieval of law reports.
- (c) Indexing, storage and retrieval of court proceedings.
- (d) Assisting the human experts in crime investigation.
- (e) Statistical analysis of criminal and civil cases in the law court and estimating the rate of growth.
- (f) Assisting the court registrar in the allocation of cases to courts.
- (g) Monitoring and evaluating congestion in police custody and prisons.
- (h) Identifying the causes of crime and assisting with the provision of preventive and curative measures.

### **3.4 Health Care**

The delivery of health care facilities has been one of the notable areas in which computer applications have proved most beneficial to mankind. The computer is used to conduct fast and accurate laboratory tests for blood, urine, stool and so on. The computer is used

in the diagnosis and physiological monitoring of patients life during surgical operation and intensive care programme. There is also a wide range of application packages for the scientific preparation and administration of drugs, x-ray techniques, blood bank management and so on. An equally important application of the computer is the computer simulation provided in the training of medical and paramedical staff and students.

Computers are being used to perform routine clerical functions in hospitals such as keeping records of hospital admission and discharges, administration of drugs and prescriptions and other hospital administrative functions. Furthermore, the computer is used to provide a data bank of medical history to meet the data needs of health insurance schemes and vital health care statistical reports.

The summary that can be drawn about the use of computers in the hospitals are as follows:

- (a) Keeping and reviewing in a timely, effective and efficient manner the records of patients, staff, drugs and equipment.
- (b) Monitoring the temperature, blood pressure, heart beat and a host of other parameters of patients and raising an alarm when abnormal situation is about to occur.
- (c) Assisting medical practitioners in the diagnosis of patient disease.
- (d) Assisting the medical practitioners in the prescription of drugs to patients and ultimately the treatment of patients.



- (e) Assisting the medical practioners in the monitoring, controlling and reviewing basic health services, birth rate, death rate, outbreak of disease and a host of others.

### **3.5 Transport and Communications**

The most dramatic computer application is witnessed in the transport and communications sectors with increased sophistication but geared towards making life easier and safer for mankind. Today, mankind world-wide is linked by computer controlled orbiting communications satellite. Telecommunications and computing are today electronically linked together. As a result, information can now be transmitted around the globe on the radio, television, telex, facsimile and so on through microwave communication satellites

Man's advancement in information technology has led to the development of the popular computer controlled electronic mail service which provides a more effective and efficient method of disseminating information to users in a computer network environment. The electronic mail service now provides faster, more convenient and cheaper electronic flow of information than the telephone, fax and telex transmission.

Computer application in communications has led to the use of computer terminals at home. This development enable viewers to read electronic newspapers on the television while the teletext provides computerized information to viewers on events around the globe in the field of politics, business, transport, sports, airline, hotel reservations and many others. the Cabled Network News (CNN) is a practical example.

Computer application is now felt in traffic control and vehicle maintenance. Traffic congestion is cities are monitored by computer controlled traffic switching system which controls traffic flows. Computer aided input devices in a form of railcards

or tickets are used to operate automatic gates in underground railway lines. When a ticket coated with magnetic stripes is slotted down wards into a device, the gate automatically opens for you to enter while you take your ticket. The device will return your ticket if it is valid for another journey; if not, it will keep the ticket and allow you to go. A passenger with an invalid ticket is given a red message and there is no way he or she can enter through the gate.

In the delivery of postal services, the computer is used to sort letters according to post codes. In the field of aeronautics, computer simulations are used to train pilots while air traffic movements are monitored by computer controlled radars. The scheduling of trains, subways, and by real-time sophisticated computer systems. Another important computer application is the introduction of computer devices to improve personal safety on aircrafts and vehicles and also to detect engine faults and help in the maintenance of aircrafts and vehicles.

### **3.6 Government**

The business of governance is a serious business. In a multi-cultural, multilingual, multi-ethnic, setting such as Nigeria, a lot of complex and often conflicting variable interplay or are taken into consideration before a broad-based decision can be taken. Computers can assist government business in the following ways:

- (a) Planning
- (b) Decision marking
- (c) Policy formulating
- (d) Monitoring and control of operations

The availability of data, timely access to the data and timely reporting on the data are very crucial to the above listed business of government. Computers can be used to:

- (a) Keep accurate records of government assets and periodically estimates the market value and insurance value.
- (b) Keep accurate records of the population, behaviour patterns, consumption patterns of utilities and estimates the distribution of basic needs such as electricity, water, telephone and postal services.
- (c) Keep records of government revenue and expenditure and assist government in monitoring, controlling and evaluating the revenue and expenditure
- (d) Keep records of government employees with a view to:
  - (i) Preventing ghost workers
  - (ii) Estimating the strength of the human resources of government
  - (iii) Producing statistical data on employees
- (e) Computers can be used in the issuance of identity cards to the citizens.
- (f) Compilation of a broad-based and accurate voters register. This will check the incidence of ghost voting, multiple voting and other electoral malpractices which has bedeviled the electoral processes and stable polity in the third world countries.
- (g) Computers are used to keep track of crime in the society thereby helping the government security agencies to check crime in the society.
- (h) Computers can be used to build and to main the database of the mineral resources and other resources of the nation.

### **3.7 The Military**

One of the areas in which computer has been applied intensively and extensively is the military. The first generation of the modern computers were designed and used during the first and the second world wars. The use of computer for processing data became more popular during these periods due to the need to procure, store and process large volume of data. Over the years, the use of computer have transcend the traditional role of “crunching numbers” to sophisticated applications. Specifically, computers are being used in the following ways, in the military operations:

- (a) Training the personnel through the use of simulated war situations.
- (b) Reconnaissance surveys.
- (c) Automatic detection of mines.
- (d) Monitoring and tracking of planes with a view to crash landing any un-authorised plane flying in the nations airspace.
- (e) Monitoring operations in the military base.
- (f) Launching of missiles from distant military base to the enemy territory. Such missiles are programmed to ensure that only the desired targets are hit.
- (g) Manufacture of state-of-the-art military hardware and consumables.
- (h) Communications and transmission of highly coded classified military information.
- (i) Military games, adventures and expeditions.
- (j) Keeping records of military personnel and logistics.
- (k) Keeping records of military assets – hardware
- (l) Management of military stock with a view to maintaining war-ready stock of materials, ammunitions and assets at any point in time.

- (m) Monitoring the environmental and storage conditions of leather weapons in order to prevent accidents like sudden explosions caused by improper storage.
- (n) Generation and maintenance of necessary data that would enhance planning, policy formulation, decision making and forecast.

### **3.8 Recreation, Amusement and Gaming**

One of the major areas in which computer has affected the society positively is in the area of recreation, amusement and gaming. “Work and no play make Jack a dull boy”. With increasing civilization and urbanization, there is the need for people to relax and keep their mind off the tension that is associated with daily activities, some of which are tension soaked.

Computer games helps one to learn in the private (even in the comfort of your own room or office), keeps you off the streets and arcades, reduces tension and boredom, engages the mind on constructive things and teaches you new skills.

There are different kinds of games such as adventure games, business games, war games, traditional games, and simulation games.

### **4.0 Conclusion**

Computer as a universal machine is being applied to almost every area of human society.

The discussions in this unit clearly demonstrate this fact.

### **5.0 Summary**

In this unit, we have discussed in details the application of computers in the following fields:

- (a) Science and Engineering
- (b) Health Care

- (c) Business and Industry
- (d) Transport and Communications
- (e) Recreation
- (f) Government
- (g) The Military

## **6.0 Tutor Marked Assignment**

Discuss the roles of computer in ensuring food security in Nigeria.

## **7.0 References and Further Reading**

Akinyokun, O.C, (1999). *Principles and Practice of Computing Technology*.

International Publishers Limited, Ibadan.

Balogun, V.F., Daramola, O.A., Obe, O.O., Ojokoh, B.A., and Oluwadare S.A., (2006).

*Introduction to Computing: A Practical Approach*. Tom-Ray Publications, Akure.

Richard H. Austing and Lillian Cassel (1986). *Computers in Focus*. Books/Cole

Publication Company. Monterey, California

Tunji and Dokun (1993). *Data Processing, Principles and Concepts*. Informatics Books, Lagos.

## **MODULE 7: THREATS TO THE COMPUTER**

This module focuses on computer virus as a major threat to the smooth operations of the computer.

### **STUDY UNIT 19: COMPUTER VIRUS**

#### **Table of Contents**

Computer virus

How to detect computer virus

Mode of transmission of computer virus

#### **1.0 Introduction**

One of the biggest fears of having computers are viruses, viruses are malicious programs designed entirely for destruction and havoc. Viruses are created by people who either know a lot about programming or know a lot about computers.

#### **2.0 Objectives**

The objective of this unit is to introduce students to the concept of computer virus, its mode of transmission, detection, prevention and cure.

#### **3.0 Computer Virus**

Computer virus is one of the greatest threats to computers and computer applications.

Once the virus is made it will generally be distributed through shareware, pirated software, e-mail or other various ways of transporting data, once the virus infects someone's computer it will either start infecting other data, destroying data, overwriting data, or corrupting software. The reason that these programs are called viruses is because it spreads like a human virus, once you have become infected either by downloading something off of the Internet or sharing software any disks or write able media that you

placed into the computer will then be infected. When that disk is put into another computer their computer is then infected, and then if that person puts files on the Internet and hundreds of people download that file they are all infected and then the process continues infecting thousands if not millions of people.

### **MODE OF TRANSMISSION OF COMPUTER VRUS**

The majority of viruses are contract by floppy's by bringing information from one source and then put onto your computer. VIRUSES can infect disks and when that disk is put into your computer your computer will then become infected with that virus, a recent survey done in 1997 by NCSA given to 80 percent of PC users showed that 90% of PC users contract viruses by floppy diskettes.

In the survey done above it showed that the other 20% of viruses were contracted by email attachments and over the Internet. This means that you received an email with an attached file and opened the file. Or downloaded a file over the Internet.

### **VIRUS PROPERTIES**

**Your computer can be infected even if files are just copied.** Because some viruses are memory resident as soon as a diskette or program is loaded into memory the virus then attaches itself into memory.

**Can be Polymorphic.** Some viruses have the capability of modifying their code which means one virus could have various amounts of similar variants.

**Can be memory / Non memory resident.** Depending on the virus can be memory resident virus which first attaches itself into memory and then infects the computer. The virus can also be Non memory resident which means a program must be ran in order to infect the computer.



**Can be a stealth virus.** Stealth viruses will first attach itself to files on the computer and then attack the computer this causes the virus to spread more rapidly.

**Viruses can carry other viruses and infect that system and also infect with the other virus as well.** Because viruses are generally written by different individuals and do not infect the same locations of memory and or files this could mean multiple viruses can be stored in one file, diskette or computer.

**Can make the system never show outward signs.** Some viruses will hide changes made such as when infecting a file the file will stay the same size.

**Can stay on the computer even if the computer is formatted.** Viruses have the capability of infecting different portions of the computer such as the CMOS battery or master

### **HOW VIRUSES MAY EFFECT FILES**

Viruses can effect any files however usually attack .com, .exe, .sys, .bin, .pif or any data files. Viruses have the capability of infecting any file however will generally infect executable files or data files such as word or excel documents which are open frequently.

**It can increase the files size, however this can be hidden.** When infecting files virtues will generally increase the size of the file however with more sophisticated viruses these changes can be hidden.

**It can delete files as the file is ran.** Because most files are loaded into memory and then ran once the program is in memory the Virus can delete the file.

**It can corrupt files randomly.** Some destructive viruses are not designed to destroy random data but instead randomly delete or corrupt files.

**It can cause write protect errors when executing .exe files from a write protected disk.** Viruses may need to write themselves to files which are executed because of this if a diskette is write protected you may receive a write protection error.

**It can convert .exe files to .com files.** Viruses may use a separate file to run the program and rename the original file to another extension so the exe is ran before the com.

**It can reboot the computer when a files is ran.** Various computers may be designed to reboot the computer when ran.

### **WHAT VIRUSES MAY DO**

The following are possibilities you may experience when you are infected with a virus. Remember that you also may be experiencing any of the following issues and not have a virus.

Once the hard drive is infected any disk that is non-write protected disk that is accessed can be infected.

- Deleted files
- Various messages in files or on programs.
- Changes volume label.
- Marks clusters as bad in the FAT.
- Randomly overwrites sectors on the hard disk.
- Replaces the MBR with own code.
- Create more then one partitions.
- Attempts to access the hard disk drive can result in error messages such as invalid drive specification.
- Causes cross linked files.

- Causes a "sector not found" error.
- Cause the system to run slow.
- Logical partitions created, partitions decrease in size.
- A directory may be displayed as garbage.
- Directory order may be modified so files such as COM files will start at the beginning of the directory.
- Cause Hardware problems such as keyboard keys not working, printer issues, modem issues etc.
- Disable ports such as LPT or COM ports
- Caused keyboard keys to be remapped
- Alter the system time / date
- Cause system to hang or freeze randomly.
- Cause activity on HDD or FDD randomly.
- Increase file size.
- Increase or decrease memory size.
- Randomly change file or memory size.
- Extended boot times
- Increase disk access times
- Cause computer to make strange noises, make music, clicking noises or beeps.
- Display pictures
- Different types of error messages

## **DETECTING VIRUSES**

The most commonly used method of protecting against and detecting viruses is to purchase a third party application designed to scan for all types of viruses. A list of these protection programs are listed above.

Alternatively a user can look at various aspects of the computer and detect possible signs indicating a virus is on the computer. While this method can be used to determine some viruses it cannot clean or determine the exact virus you may or may not have.

### **4.0 Conclusion**

Computer viruses are perhaps the greatest threats to the computer. If not detected and promptly cured, computer virus attack could lead to the total breakdown of computer a installation. With the aid of our discussion in this unit, students should be able to prevent, detect and clean viruses in a computer installation.

### **5.0 Summary**

In this unit we have learnt the following:

- (a) That computer viruses are programs written by programmers with the aim of causing havoc to the computer.
- (b) Computer viruses could lead to malfunctioning and total breakdown of the computer.
- (c) Computer viruses are transferred from one computer to another through the use of infested storage media such as diskette, flash drive, CDROM, or across a computer network.
- (d) There are antivirus packages specially written to prevent, detect and clean viruses.

## **6.0 Tutor Marked Assignment**

- (a) What is a computer virus?
- (b) What are the differences and similarities between biological viruses and computer viruses?
- (c) How would you prevent virus attack in the student's computer laboratory.

## **7.0 References and Further Reading**

Akinyokun, O.C, (1999). *Principles and Practice of Computing Technology*.

International Publishers Limited, Ibadan.

Balogun, V.F., Daramola, O.A., Obe, O.O., Ojokoh, B.A., and Oluwadare S.A., (2006).

*Introduction to Computing: A Practical Approach*. Tom-Ray Publications,

Akure.