



# STANDARD EIGHT

K.C.P.E REFLECTOR

K.C.P.E REFLECTOR

## STD 8 EXAMS AND M/SCHEMES



COMPLETE STD 8 EXAMS AND M/SCHEMES



# STANDARD EIGHT

## K.C.P.E REFLECTOR

### MATHEMATICS

**Time: 2 hours**

#### READ THESE INSTRUCTIONS CAREFULLY

1. You have been given this question booklet and a separate answer sheet. The question booklet contains 50 questions.
2. Do any necessary rough work in this booklet.
3. When you have chosen your answer, mark it on the **ANSWER SHEET**, not in the question booklet.

#### HOW TO USE THE ANSWER SHEET

4. Use only an ordinary pencil.
5. Make sure that you have written on the answer sheet:
  - YOUR INDEX NUMBER**
  - YOUR NAME**
  - NAME OF YOUR SCHOOL**
6. By drawing a **dark line** inside the correct numbered boxes mark your full Index Number (i.e. School Code Number and the three-figure Candidate's Number) in the grid near the top of the answer sheet.
7. Do not make any marks outside the boxes.
8. Keep your answer sheet as clean as possible and **DO NOT FOLD IT**.
9. For each of the questions 1 – 50 four answers are given. The answers are lettered A, B, C and D. In each case only **ONE** of the four answers is correct. Choose the correct answer.
10. On the answer sheet, the correct answer is to be shown by drawing a **dark line** inside the box in which the letter you have chosen is written.

#### Example:

In the question booklet:

15. What is the square root of 0.7056?  
 A. 0.84  
 B. 8.4  
 C. 0.0084  
 D. 84.0

The correct answer is **A** (0.84)

On the answer sheet:

5 | A | B | C | D |    
  15 | A | B | C | D |    
  25 | A | B | C | D |    
  35 | A | B | C | D |    
  45 | A | B | C | D |

In the second set, the box with the letter **A** printed in it is marked.

11. Your **dark line** **MUST** be within the box.
12. For each question **ONLY ONE** box is to be marked in each set of four boxes.

**TURN OVER**



- What is sixteen million sixty thousand six hundred and sixteen written in symbols?  
A. 1660616  
B. 1606660  
C. 16060616  
D. 60060616
- What is the value of  $72 \times 5 \div 60 - 3 \div 6 \times 4 + 3$ ?  
A. 7  
B. 1  
C. 3  
D. 5
- There are 486297 people in town A, 851096 people in town B and 1238804 people in town C. What is the total number of people in the three towns to the nearest hundred thousand?  
A. 2580000  
B. 2600000  
C. 3000000  
D. 2500000

- Work out the value of

$$\frac{1}{3} \text{ of } \frac{3}{4} \div \left[ \frac{1}{2} + \frac{1}{4} \right] - \frac{2}{3} \times \frac{1}{4}$$

- $\frac{1}{3}$
  - $\frac{1}{6}$
  - $\frac{2}{3}$
  - $\frac{3}{4}$
- If 29<sup>th</sup> May 2019 was on a Wednesday, on which day was 14<sup>th</sup> March 2019?  
A. Friday  
B. Wednesday  
C. Monday  
D. Thursday
  - In the figure below, line XW is parallel to line YZ and line XU = WZ. Line VTU and line VWZ are straight lines. What is the value of angle VTW?

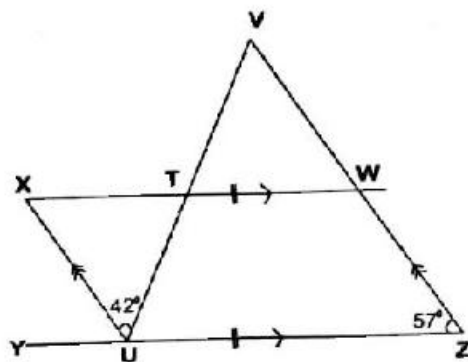

- $99^\circ$
- $91^\circ$
- $89^\circ$
- $81^\circ$



7. Planet **A** takes 6 years to revolve round the sun while planet **B** and **C** take 9 years and 15 years respectively. They all completed their revolution together in 1998. Which year had they previously completed their revolution together again?

A. 1995  
 B. 2088  
 C. 1908  
 D. 2001

8. The figure below represent a piece of wood in which a section has been removed. What is the volume of the remaining materials?

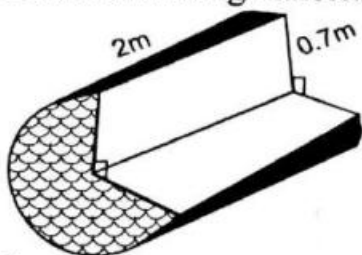

A.  $1.54\text{m}^3$   
 B.  $1.55\text{m}^3$   
 C.  $2.64\text{m}^3$   
 D.  $2.31\text{m}^3$

9. What is the next number in the sequence 0.04, 0.09, 0.25, 0.49, \_\_\_\_\_?

A. 0.81  
 B. 0.081  
 C. 0.121  
 D. 1.21

10. What is the value of **x** in the equation

$$4\left(\frac{1}{2}x - 1\right) = \frac{1}{5}(5x + 30)?$$

A. 10  
 B. 8  
 C. 5  
 D. 3

11. Chezebe bought the following items from the hardware.

3 jembes @ sh. 250

5 pangas @ sh. 150

2 spades for sh. 330

A wheel barrow @ sh. 2500

A hammer @ 320

How much balance did she get back after paying the bill using sh. 5000?

A. Sh. 540  
 B. Sh. 560  
 C. Sh. 350  
 D. Sh. 20



12. A group of 40 pupils and 5 teachers went for a tour. 25 pupils and three teachers boarded a minibus while the others boarded a nissan. Teachers in the nissan paid 350 each while those in the minibus paid 300 each. Pupils in the minibus paid 250 each while the others paid sh. 300 each. How much money was paid for the transport altogether?
- A. Sh. 11750  
 B. Sh. 12850  
 C. Sh. 12350  
 D. Sh. 13250

13. What is the area of the shaded part in the figure below?

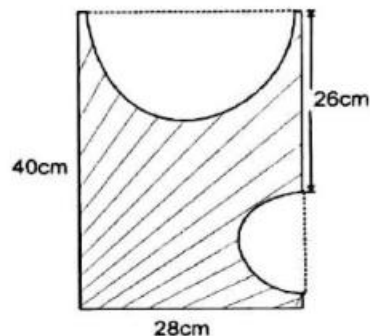

- A.  $1120 \text{ cm}^2$   
 B.  $616 \text{ cm}^2$   
 C.  $385 \text{ cm}^2$   
 D.  $735 \text{ cm}^2$
14. Rhoda deposited sh. 18000 in a bank that pays simple interest per annum. After two years the account had sh. 19260. At what rate did the bank pay as interest?
- A. 10%  
 B. 5%  
 C.  $2\frac{1}{2}\%$   
 D.  $3\frac{1}{2}\%$
15. Romil's salary was sh. 15000. It was increased by 10% each year. What was his salary after 2 years?
- A. Sh. 18150  
 B. Sh. 16500  
 C. Sh. 18000  
 D. Sh. 3150
16. In a test that was marked out of 40, Murimi scored 70%. What was his raw mark?
- A.  $\frac{14}{40}$   
 B.  $\frac{70}{100}$   
 C.  $\frac{7}{10}$   
 D.  $\frac{28}{40}$



17. The tank below was full of juice. The juice was then packed into 2dl packets. How many packets of juice were obtained?

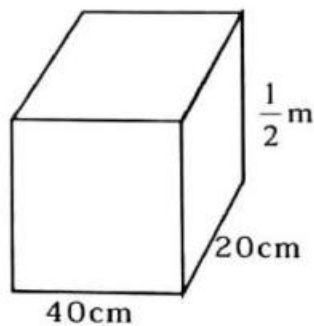

- A. 400  
B. 40  
C. 200  
D. 20
18. A factory produced 36000 tonnes of biscuits.  $\frac{1}{4}$  of the biscuits were sold in Nairobi,  $\frac{1}{3}$  of the remainder in Thika and the rest were distributed equally among Nakuru, Embu and Eldoret. How many tonnes were sold in Thika and Embu altogether?
- A. 27000t  
B. 15000t  
C. 18000t  
D. 12000t
19. In the figure below, line  $AB=AC=CD$ . Angle  $BAC=40^\circ$ . What is the value of angle  $BAD$ ?

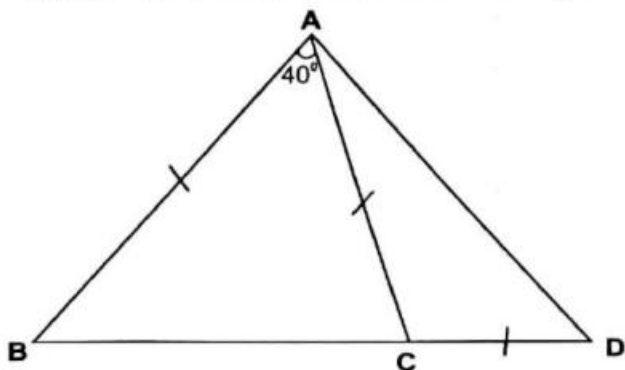

- A.  $75^\circ$   
B.  $70^\circ$   
C.  $35^\circ$   
D.  $110^\circ$

Working Space



20. Ochieng's stride is 7.2dm long. He made 200 strides from his home to the shop. What is the distance from his home to the shop in metres?
- A. 14400m  
B. 1440m  
C. 144m  
D. 14.4m
21. The area of the square plot is 0.0324 hectares. It was fenced using 3 strands of wire. What was the total length of wire used?
- A. 72m  
B. 144m  
C. 90m  
D. 216m
22. A shopkeeper bought 4-90kg bags of maize flour. She then bought 3-60kg bags of maize flour. Later she packed all the flour into 2kg packets. How many packets did she obtain?
- A. 540  
B. 270  
C. 1080  
D. 720
23. A saleslady is paid a basic salary of sh. 11000 and a commission on all goods sold above sh. 20000. In one month, she sold goods worth sh. 100000 and got a total earnings of sh. 13000. What was the percentage commission offered?
- A. 10%  
B. 5%  
C. 2%  
D.  $2\frac{1}{2}\%$
24. In an election, three candidates contested for a seat. The winning candidate got 2436 votes more than the second candidate. The third candidate got 932 votes less than the second candidates. If 308 votes were spoiled, how many votes were cast if the third candidate got 3533 votes?
- A. 14899  
B. 15207  
C. 14591  
D. 6901
25. Draw a rhombus **ABCD** such that line **AB**= 7cm and angle **ABC**= 110°. Drop a perpendicular from point **A** and let perpendicular meet line **CD** at point **E**. Measure line **ED**.
- A. 6.5cm  
B. 3.8cm  
C. 2.3cm  
D. 5.2cm



26. Simplify the algebraic expression given.

$$\frac{1}{2}(6x + 8y) + \frac{2}{3}(9x - 3y)$$

- A.  $6x - 2y$
- B.  $9x + 2y$
- C.  $9x + 6y$
- D.  $9x - 2y$

27. The figure below represents an open box. What is its total surface area?

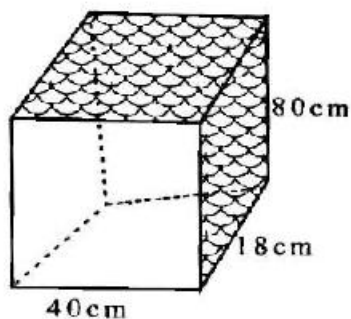

- A.  $1000\text{cm}^3$
- B.  $7520\text{cm}^3$
- C.  $9280\text{cm}^3$
- D.  $10720\text{cm}^3$

28. The table below represents the mass of 20 pupils in a class.

Mass in kg	25	27	30	35
No. of pupils	4	8	5	3

What was the modal mass?

- A. 8kg
- B. 35kg
- C. 27kg
- D. 3kg

29. A trader sold a phone for sh. 6400 making a loss of 20%. Another trader sold a similar phone making a profit of 10%. What was the difference in their selling prices?

- A. Sh. 8000
- B. Sh. 3200
- C. Sh. 1600
- D. Sh. 2400





30. The sketch below represent a ladder used by a painter to climb a wall. It leaned on the wall as shown below. What is the height of the wall.

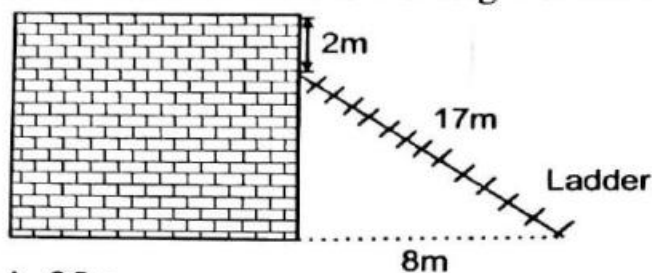

- A. 25m  
 B. 15m  
 C. 17m  
 D. 9m
31. Arrange the following fractions in ascending order.

$$\frac{4}{9}, \frac{3}{7}, \frac{2}{5}, \frac{1}{2}$$

A.  $\frac{4}{9}, \frac{2}{5}, \frac{3}{7}, \frac{1}{2}$

B.  $\frac{3}{7}, \frac{1}{2}, \frac{2}{5}, \frac{4}{9}$

C.  $\frac{1}{2}, \frac{4}{9}, \frac{2}{5}, \frac{3}{7}$

D.  $\frac{2}{5}, \frac{3}{7}, \frac{4}{9}, \frac{1}{2}$

32. A motorist left town A for town B at 9.40 am.

After travelling for  $1\frac{1}{2}$  hours, his car had a puncture that took him 35 minutes to repair. He arrived at town B at 1.10pm. If the distance from town A to B is 378km, what was his average speed in m/s?

- A. 25m/s  
 B. 30m/s  
 C. 35m/s  
 D. 20m/s

33. A pair of trouser costs sh. t. A pair of short costs sh. 60 while a shirt costs a quarter the cost of a pair of short. Nzilani paid sh. 1500 for the three items. Which of the following equation can be used to find the cost of a pair of trouser?

A.  $2\frac{1}{4}t - 45 = 1500$

B.  $9t - 300 = 6000$

C.  $2\frac{1}{4}t + 75 = 1500$

D.  $9t + 300 = 6000$



34. In a farm, the ratio of sheep to goats is 1:2 while that of goats to cows is 5:2. If there are 8 cows, how many animals are there in the farm?
- A. 24  
B. 32  
C. 36  
D. 38

35. The stack below was dipped in blue paint. How many cubes did not get paint at all?

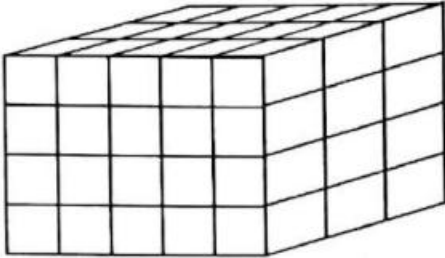

- A. 4  
B. 6  
C. 8  
D. 12
36. On a map whose scale is 1:60000, a river is represented by a line of  $2\frac{1}{2}$  cm long. What is the actual length of the river in Kilometres?.
- A. 1.2km  
B. 2.4km  
C. 1.5km  
D. 3km
37. Kingori was given a discount of 15% on a pullover. Wambui was given a discount of 10% on a skirt. Each of them paid sh. 765. What was the total marked price cost of the pullover and skirt?
- A. Sh. 1750  
B. Sh. 1430  
C. Sh. 1800  
D. Sh. 2400
38. What is the value of  $\frac{2.4 \times 0.91 \times 14}{13 \times 0.07 \times 1.2}$ ?

- A. 28  
B. 2.8  
C. 0.28  
D. 0.28



39. The area of a square plot is 10.24 Ares. Find its perimeter.
- 128m
  - 256m
  - 64m
  - 32m
40. 0.2 of the oranges in a bag were rotten. 0.5 of the remainder were not ripe. How many oranges were ripe if there were 300 oranges in the bag?
- 150
  - 240
  - 120
  - 60
41. Twenty four woman can thatch a roof in 3 hours. How many more woman are needed to thatch the roof in 2 hours?
- 36
  - 12
  - 33
  - 18
42. Construct triangle  $FGH$  in which line  $FG=6.5\text{cm}$ ,  $GH=4.5\text{cm}$  and angle  $FGH=130^\circ$ . Draw a circle touching its vertices. What is the measure of its diameter?
- 1.1cm
  - 6.7cm
  - 2.2cm
  - 13.4cm
43. If  $a=3$ ,  $b=4a$  and  $c=\frac{1}{2}b$ , What is the value of  $\frac{ac^2}{b} + \frac{1}{2}b(2c-a^2)$ ?
- 18
  - 27
  - 36
  - 72
44. The mean age of seven boys is 6 years. The mean age of other two boys is  $10\frac{1}{2}$  years. What is the mean age of all the boys?
- 7 yrs
  - 8 yrs
  - 9 yrs
  - 10 yrs
45. A room measures 8 m by 6m. A carpet was laid leaving a leaving a uniform margin of 1.5m from the wall. What is the perimeter of the carpet?
- 15m
  - 16m
  - 99m
  - 40m



## Working Space

46. The table below shows the results of different teams in Kenya premier league. 3 points were awarded for each game won, 1 point was awarded for a draw and no point for any game lost.

	Win	draw	lose
Gor Mahia	3	3	3
AFC Leopards	3	4	2
Sonny Sugar	2	4	3
Mathare united	4	2	3

Which team was ranked the first in the league?

- A. AFC Leopards  
 B. Mathare United  
 C. Gor Mahia  
 D. Sonny Sugar
47. The hire purchase price of a phone is sh. 29000. Muya bought the phone by paying a deposit of sh. 9800 and the rest in equal monthly installments for 1 year. How much was each instalment?  
 A. Sh. 1920  
 B. Sh. 1200  
 C. Sh. 1800  
 D. Sh. 1600
48. What is the place value of digit 7 after working out  $260.375 \div 5$ ?  
 A. Tenths  
 B. Thousands  
 C. Hundredths  
 D. Ones
49. The pie chart below shows how Ali spends his income.

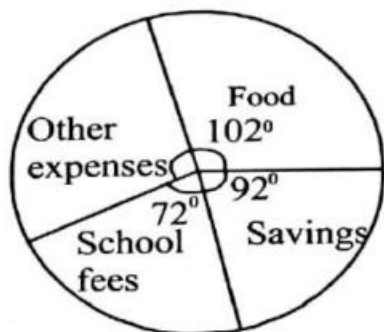

If he saves sh. 2760, how much more does he spend on other expenses than on school fees?

- A. Sh. 2820  
 B. Sh. 660  
 C. Sh. 2160  
 D. Sh. 1080



50. The graph below shows the journey of a motorist and a cyclist. The cyclist is travelling from town X to Y while the motorist is travelling from town Y to X.

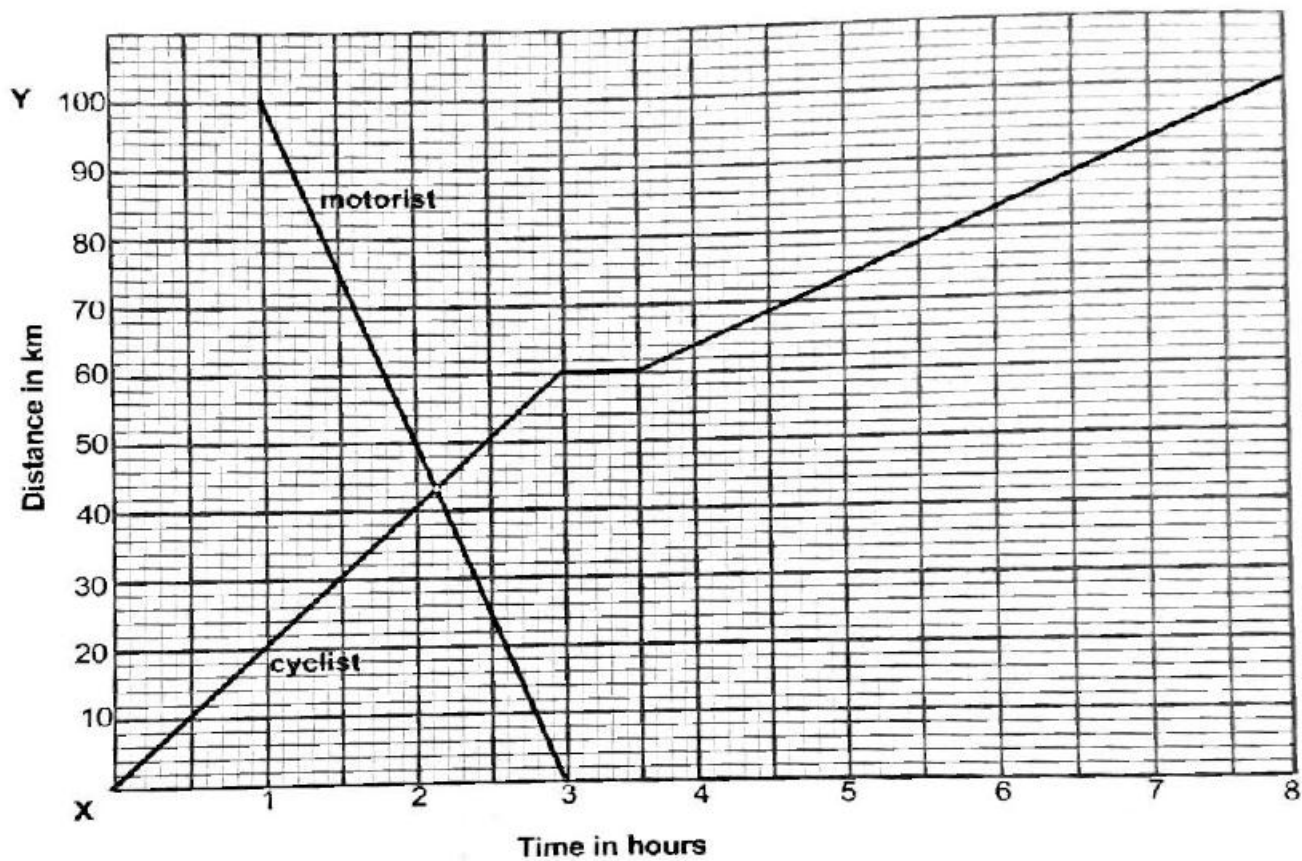

How far apart were the two travellers after the motorist had travelled for  $\frac{1}{2}$  hour?

- A. 75km
- B. 30km
- C. 45km
- D. 70km



# STANDARD EIGHT

## K.C.P.E REFLECTOR

### ENGLISH SECTION: A

Time: 1 hour 40 minutes

#### READ THESE INSTRUCTIONS CAREFULLY

1. You have been given this question booklet and a separate answer sheet. The question booklet contains 50 questions.
2. Do any necessary rough work in this booklet.
3. When you have chosen your answer, mark it on the **ANSWER SHEET**, not in this question booklet.

#### HOW TO USE THE ANSWER SHEET

4. Use only an ordinary pencil.
5. Make sure that you have written on the answer sheet:  
**YOUR INDEX NUMBER**  
**YOUR NAME**  
**NAME OF YOUR SCHOOL**
6. By drawing a **dark line** inside the correct numbered boxes mark your full Index Number (i.e. School Code Number and the three-figure Candidate's Number) in the grid near the top of the answer sheet.
7. Do not make any marks outside the boxes.
8. Keep your answer sheet as clean as possible and **DO NOT FOLD IT**.
9. For each of the Questions 1 – 50 four answers are given. The answers are lettered A, B, C, D in each case only **ONE** of the four answers is correct. Choose the correct answer.
10. On the answer sheet show the correct answer by drawing a **dark line** inside the box in which the letter you have chosen is written.

#### Example

For question 25 choose the best alternative to complete the proverb given..

- 25.** Too many cooks  
A. the work becomes easy  
B. make a delicious meal  
C. barely work together  
D. spoil the broth.

The correct answer is D (spoil the broth)

**5.** |A| |B| |C| |D|    **15.** |A| |B| |C| |D|    **25.** |A| |B| |C| |D|    **35.** |A| |B| |C| |D|    **45.** |A| |B| |C| |D|

#### On the answer sheet

In the set of boxes numbered **25**, the box with letter **D** printed in it is marked.

11. Your **dark line** **MUST** be within the box.
12. For each question **ONLY ONE** box is to be marked in each set of four boxes.

This question paper consist of 7 printed pages

**TURN OVER**



**Read the passage below. It contains blank spaces numbered 1 to 15. For each blank space, choose the best alternative from the choices given.**

Food is essential to us and whoever fails to eat for a number of days is 1 to grow too 2 to perform any given task. Food makes us grow healthy and if 3 looks at us, it leaves no 4 that eating well is what keeps us 5. There are many types of food and they are cooked in a 6 of methods. Different cooking styles are 7 by different people, depending on the taste, smell, texture, consumers and even culture. Eating 8 be controlled 9 as it also has effects which come due to 10 of eating the same food, quantity eaten or allergy.

Eating 11 much could make you be called a glutton. You should eat 12 enough so that the stomach can easily 13 it. Food should be chewed 14 before being swallowed. Balance your 15 and choose fresh and good quality of food to stay healthy.

- |                |               |             |               |
|----------------|---------------|-------------|---------------|
| 1. A. likely   | B. certain    | C. probable | D. certain    |
| 2. A. small    | B. thin       | C. weak     | D. young      |
| 3. A. anybody  | B. somebody   | C. any body | D. everybody  |
| 4. A. reason   | B. space      | C. room     | D. doubt      |
| 5. A. live     | B. life       | C. alive    | D. living     |
| 6. A. special  | B. variety    | C. specific | D. various    |
| 7. A. desired  | B. expected   | C. planned  | D. decided    |
| 8. A. could    | B. must       | C. would    | D. might      |
| 9. A. moreover | B. surely     | C. however  | D. more so    |
| 10. A. mastery | B. overeating | C. method   | D. repetition |
| 11. A. too     | B. so         | C. very     | D. any        |
| 12. A. even    | B. also       | C. or       | D. just       |
| 13. A. save    | B. keep       | C. digest   | D. clear      |
| 14. A. fast    | B. properly   | C. hard     | D. slowly     |
| 15. A. diet    | B. food       | C. meals    | D. eating     |



*For questions 16 - 18, choose the word (s) that can best replace the underlined words.*

16. It is dangerous to walk alone at night because of armed group of people who could harm you.  
 A. mob  
 B. crowd  
 C. squad  
 D. gang
17. Shops that sell pens, pencils, rubbers and exercise books are rarely empty when schools are opening.  
 A. stationery  
 B. materials  
 C. stationary  
 D. requirements.
18. Our school has a lovely garden of mango, orange, pawpaw and bananas.  
 A. plantation  
 B. fruit farm  
 C. orchard  
 D. greenhouse.

*In questions 19 and 20, select the question tag that correctly completes the sentence.*

19. He knows all of us by name, \_\_\_\_\_?  
 A. didn't he  
 B. doesn't he  
 C. isn't it  
 D. does he
20. They find it difficult to concentrate, \_\_\_?  
 A. do they  
 B. couldn't they  
 C. don't they  
 D. are they

*In questions 21 and 22, select the alternative that best replaces the underlined phrase in the given sentence.*

21. The family moved away because they could not put up with the neighbour's noise.  
 A. accommodate  
 B. accept  
 C. receive  
 D. tolerate.
22. Sara has not made up her mind on which course to study at the university.  
 A. decided  
 B. thought  
 C. accepted  
 D. planned.

*In questions 23 and 24, choose the alternative that means the opposite of the underlined word.*

23. Wearing black leather shoes is allowed in our school.  
 A. discouraged  
 B. forbidden  
 C. optional  
 D. advised.
24. Eating food given to you by a stranger as you travel is very risky.  
 A. harmful  
 B. dangerous  
 C. comfortable  
 D. safe.

*In question 25, choose the sentence that is correctly punctuated.*

25. A. "Childrens' clothes." Moses's mother said, "Are quite expensive".  
 B. "Children's clothe's" Moses mother said. "Are quite expensive."  
 C. "Children's clothes," said Moses' mother, "are quite expensive."  
 D. "Childrens' clothes", Moses' mother said, "are quite expensive".





**Read the passage below and answer questions 26-38.**

That day we were not in for any mischief. Somehow, I would now say, mischief came looking for us. We had to be dutifully herding goats and playing our self-invented games when we felt like moving to another area to give the goats a change of scene. It was already getting late so we knew all had been done fast but when we realised that one of the black goats was missing, we knew we had to stop all our activities and ensure we locate it. Losing even a kid would not be taken kindly at home.

We knew the best way to do this. Each of us left in a different direction and was eager to be the one to find the stray goat. However, we were careful enough to leave Tatia to take care of the rest. If we didn't, we would then have to look for the whole herd and that could be a real task. We instructed him to wait for us at the spot where we left him so that movement home would be uniform.

I chose the path towards the river. It was bushy and that is what the stubborn animal would likely get attracted to. I half-ran-half-walked, hoping that every step I made brought me closer to the goat but it didn't. Then, I bumped into some boys carrying reed basket. How I wish I ignored them as it was them who landed me in trouble that day.

I greeted one of them and enquired if they had seen any lost goat but before I could do so, what they were eating attracted me and I found myself salivating. Each of them had a freshly harvested sweet potato, yellowish in colour. I asked one of them to allow me bite a piece but instead, he shocked me by offering the whole potato! I did not ask them about the goat.

I moved on, eating the sweet potato and hoping it does not reduce in size. The path was winding and it was not possible to see what was ahead. It is this that drove me directly into the hands of the man who had a thick stick in the hand. He grabbed me and without wasting time, called me a thief! I was again shocked. He asked me to produce the others but my mouth was too dry to utter a word. Then I pointed at the direction the boys had taken. Instead of leaving me alone, he ruthlessly dragged me with him and as if my angels had been following this move with open eyes, his attention was attracted to by the boys, running away at a top speed and laughing at the top of their voices. He calmed down and asked me to reveal the mystery to him. It was then that we realised the truth of what had happened. The man left me just at the same time the bleating black goat sprang from the bushes as if it had been looking for us.



26. From the first sentence of the passage, it is true to say that the boys
- had been warned against involving in mischief
  - had stopped being mischievous completely
  - knew they could be punished for involving themselves in mischief
  - did not like involving themselves in mischief all the time.
27. How did mischief go looking for the boys?
- It frequented the place where the boys played.
  - It came without their knowledge.
  - Rarely could they find a safe place from mischief.
  - They did not know how to identify mischief.
28. The boys decided to take the goats to another area because
- they wanted the goats to feed better
  - they had some things to do at the new area
  - they wanted to keep away from any form of mischief
  - the goats had stopped eating where they were.
29. According to the boys, losing even a kid
- would show that they had been playing
  - is what would make them stop herding
  - had made their parents direct them where to herd
  - could lead them into problems with their parents.
30. The way in which the boys left to go searching for the lost goat shows that
- they knew exactly where the goat was
  - each of them was to use trial and error method
  - they had experience in looking for a lost animal
  - they were very unlikely to get the lost goat.
31. As soon as the writer bumped into the boys carrying the reed basket, he
- stopped running immediately
  - decided to ignore them
  - realised his trouble had just started
  - was unaware of what was in store for him.
32. What made the writer to engage with the boys?
- The need for the sweet potatoes.
  - The location of the lost goat.
  - To be told where the sweet potatoes had come from.
  - He could not trace any of his friends.
33. At what point in time did the writer ask about the lost goat?
- Other factors made him not address this issue.
  - Immediately he met the boys carrying the basket.
  - Just after being offered the sweet potatoes.
  - Before he asked to be given the sweet potato to bite.
34. Tatia was left behind by the other boys because
- he was not good at looking for lost goats
  - he did not know the colour of the lost goat
  - they had been put under control too
  - the goat had got lost while he was playing.
35. The location the writer chose to go and look for the lost goat
- could enable him move fast
  - is where the lost goat had been seen last
  - was the most notorious area that goats disappeared at
  - was the most ideal for its recovery.
36. Why do you think one of the boys readily gave the writer one sweet potato?
- He wanted to put the writer in trouble.
  - The writer looked very miserable.
  - He had more than enough in the basket.
  - The potatoes were heavy and they needed to hurry.
37. The writer escaped punishment because
- the man realised he was not the thief
  - he had not yet got the lost goat
  - his angels were guarding him
  - he directed his captor in the right direction.
38. The time the boy was released and that of the recovery of the goat happened as
- anticipated.
  - a coincidence
  - planned
  - a surprise.



**Read the passage below and then answer questions 39 to 50.**

A number of young learners work hard with hope of being a soldier in life one day. When they look at the men and women in uniform, marching or going through their drills, it looks attractive and makes them feel like being soldiers. This is for both personal gains and the feel of being able to serve their country.

The army will train you in many areas, including being a cook. That means that every single person in the army is someone that can survive behind enemy lines for long. If duty dictates that you be on your own somewhere as a soldier, you would survive. In the army, one day you can be the person who is fighting deep behind the enemy lines and the next day, you are the person making coffee and the following day, discussing financial matters.

You have to be able to lead yourself. It has to do with the wide scope of training you undergo. Do not stop at the point where you have qualified and have the expertise. It does not stop at that. It goes all the way to the limit of learning, which is never. Things keep changing, wisdom changes and so does knowledge. People will recommend things just because it worked for them back then but probably it did by sheer luck.

Learning is an integral part of leading and so, a leader is expected to keep learning. In the forces, they say that when you fall, fall forward. This means learning out of what you go through so, you pick the lessons to live better tomorrow, to guarantee success.

The focus for soldiers is not even on the physical courage because that is a requirement for you to be a soldier. The most important aspect is the moral courage. That is the ability to do the right thing even if it sets you up for ridicule or turns out to be something unpopular. Those people will one day come around to knowing that you actually did the right thing. Always stick to your values and be a person of integrity. A man is only as good as his words and at times, his actions too.

Physical fitness is a necessity in the military. The duty itself demands it. No one will tell you that you needed to wake up and work out or run. You know that a mission can come up any time, like going to Mount Elgon or Somalia and your physical shape will need to be on the point. The result of pushing yourself to your limits physically is that you develop toughness. It drives you to a point that you have a lot of confidence in yourself and ready to face any kind of situation because of your strong personality.

Mental toughness is what may carry you through difficult situations. It will help you dig in even if the times are bad. Mental toughness is a necessity for survival and everything you want to achieve in life. If you just settle in a comfort zone, which sadly most people are in, in the long run, it will come to haunt you. You will never live a life of satisfaction if you do not have mental toughness.



39. Many young people hope to become soldiers because
- they have the courage to serve their nation
  - it is the job that can make them work hard
  - of how the soldiers look
  - the soldiers attract them to join the forces.
40. What happens when one is recruited to become a soldier?
- He ends up being trained in many areas.
  - He learns how to march and attract the youth.
  - He immediately learns how to survive alone.
  - He stops doing all the things he used to do earlier.
41. According to the passage, the training in the armed forces
- makes them to be able to endure a lot of hardship
  - has a lot to do with marching and being smart
  - makes them specialise in a specific profession
  - is aimed at making them all round in life.
42. What does the writer mean by saying one has to be self-driven in the army?
- Each soldier should not be directed on routine issues.
  - No soldier should do things in the same way daily.
  - They are not allowed to do things in groups.
  - Drivers are not employed for soldiers.
43. Learning, according to the passage, stops when
- one has been fully trained
  - you stop living
  - there's nothing more to learn from others
  - the trainers say you have qualified.
44. As wisdom and knowledge keep changing
- people keep acquiring different ideas about learning
  - it leaves people confused throughout
  - no one seems to know what is right or wrong
  - so is the necessity to keep learning.
45. You should not fear to fail while learning because
- it is not your first time to fail
  - soldiers fail to do many tasks allocated
  - even failure itself is a lesson
  - people in other professions too do fail.
46. A soldier is expected to have physical courage as well as
- discipline
  - moral courage
  - wisdom
  - sheer luck.
47. What should one do to guarantee success?
- One should not stop learning.
  - Be choosy on what you prefer learning.
  - Learn but when you fail, do something else.
  - Identify what worked well for others and try.
48. Going to Mount Elgon or Somalia is given in the passage as
- areas that are considered most dangerous
  - places where soldiers are taken to test their fitness
  - where lazy soldiers are transported to.
  - reason why one should be continuously fit.
49. Why are many people considered to be in comfort zone?
- Many people are not soldiers by profession.
  - They do not like involving themselves in tasks.
  - It is the zone where many sad people can voluntarily go.
  - There are many comfort zones to accommodate them.
50. What would be the best summary for this passage?
- Not all young people who want to be soldiers get recruited.
  - Some soldiers can do better as cooks or accountants.
  - Training in the armed forces covers many spheres in life.
  - All we need in life is to succeed throughout.



# STANDARD EIGHT

K.C.P.E REFLECTOR

K.C.P.E REFLECTOR

**ENGLISH**

**SECTION B**

**COMPOSITION**





A series of horizontal lines for writing, spanning the width of the page.



A series of horizontal lines for writing, spanning the width of the page.





# STANDARD EIGHT

## K.C.P.E REFLECTOR

K.C.P.E REFLECTOR

### KISWAHILI SEHEMU: A

**Muda: Saa 1 dakika 40**

#### SOMA KWA MAKINI MAAGIZO YAFUATAYO

- Umepewa kijitabu hiki cha maswali na karatasi ya kujibia. Kijitabu hiki kina maswali 50.
- Ikiwa utataka kuandika chochote ambacho si jibu andika katika kijitabu hiki.
- Ukisha chagua jibu lako lionyeshe katika **KARATASI YA MAJIBU** na wala sio katika kijitabu hiki cha maswali.

#### JINSI YA KUTUMIA KARATASI YA MAJIBU

- Tumia penseli ya kawaida.
- Hakikisha ya kwamba yafuatayo yameandikwa katika karatasi ya majibu:  
**NAMBA YAKO YA MTIHANI**  
**JINA LAKO**  
**JINA LA SHULE YAKO**
- Kwa kuchora kistari katika visanduku vyenye namba zinazokuhusu, onyesha namba kamili ya mtihani (yaani namba ya shule, na zile namba tatu za mtahiniwa) katika sehemu iliyotengwa mwanzo wa karatasi ya majibu.
- Usitie alama zozote nje ya visanduku.
- Iweke safi karatasi yako ya majibu.
- Kwa kila swali 1 – 50 umepewa majibu manne. Majibu hayo yameonyeshwa kwa herufi A, B, C na D. Ni jibu **MOJA** tu kati ya hayo manne ambalo ni sahihi. Chagua jibu hilo.
- Kwenye karatasi ya majibu, jibu sahihi lionyeshwe kwa kuchora kistari katika kisanduku chenye herufi uliyochagua kuwa ndilo jibu.

**Mfano**

**Katika kijitabu cha maswali:**

- 21.** Ni neno lipi ambalo si kisawe cha neno ‘fikiri’?
- Waza
  - Dadisi
  - Dhani
  - Tafakari

Jibu sahihi ni **B (Dadisi)**

**Katika karatasi ya majibu**

**1** (A) (B) (C) (D)    **11** (A) (B) (C) (D)    **21** (A) (B) (C) (D)    **31** (A) (B) (C) (D)    **41** (A) (B) (C) (D)

Katika visanduku vinavyoonyesha majibu ya swali namba 21, kisanduku chenye herufi **B** ndicho kilichochoywa kistari.

- Chora kistari chako vizuri. Kistari chako kiwe cheusi na kisijitokeze nje ya kisanduku.
- Kwa kila swali, chora kistari katika kisanduku kimoja tu kati ya visanduku vinne ulivyopewa.

**GEUZA UKURASA**



**Soma vifungu vifuatavyo. Vina nafasi 1 mpaka 15. Kwa kila nafasi, umepeva majibu manne hapo. Jaza kila pengo kwa kuchagua jawabu lifaalo zaidi.**

Mjadala kabambe unaendelea kuhusu 1 ni vyema 2 mali mtoto wa kike. Ukichunguza utagundua kuwa 3 jamii zote 4 mtoto wa kike kwa miaka mingi. Aghalabu mzazi anapoandika 5 wake, atajipata 6 mbali yule wa kike huku akichukulia kwamba punde tu 7 na kujiunga na wakwe 8. Jambo hili linastahili kukomeshwa na wote kwa kuzingatia methali inayotuongoza kwamba 9.

- |                          |                   |                   |                  |
|--------------------------|-------------------|-------------------|------------------|
| 1. A. angalau            | B. iwapo          | C. kefu           | D. kwamba        |
| 2. A. kuyarithisha       | B. kuirithisha    | C. kumrithisha    | D. kumridhisha   |
| 3. A. nusura             | B. kweli          | C. madhali        | D. yamkini       |
| 4. A. wamempuuzia        | B. imewapuuzia    | C. zimewapuuzia   | D. zimempuuzia   |
| 5. A. usiahi             | B. wasia          | C. udhia          | D. udhuru        |
| 6. A. akimpuuzilia       | B. akimpuuzia     | C. akimpuuzia     | D. akimpumzisha  |
| 7. A. atapata jiko       | B. atajipa moyo   | C. atapata nyumba | D. atapata mwao  |
| 8. A. mwake              | B. zake           | C. yake           | D. wake          |
| 9. A. umemla ndovu mzima | B. ukimlea mwana  | C. mtoto umleavyo | D. mchelea mwana |
| ukashindwa na mkia       | mwema na mui mlee | ndivyo akuavyo    | kulia hulia yeye |

Tatizo 10 kuzorota kwa usalama linatishia 11 uchumi wa nchi yetu. Sekta nyingi 12 taifa hili kupiga hatua zimeathiriwa pakubwa. Miji yetu imekuwa si salama tena. Imekuwa 13 kusikia kuwa jamaa fulani amepigwa kabari, mwingine ametekwa nyara au kuporwa mali. Chambilecho wahenga, usipoziba ufa utajenga ukuta. Lazima tatizo hili lishughulikiwe mapema kabla halijakuwa dongandugu. Wazee 14 vijana wanafaa kushirikiana 15 amani. Wahalifu wote waripotwiwe kwa polisi. Pamoja tutaweza kuifanya nchi yetu kuwa salama.

- |                            |                     |                      |                            |
|----------------------------|---------------------|----------------------|----------------------------|
| 10. A. la                  | B. za               | C. cha               | D. pa                      |
| 11. A. kuisambaratisha     | B. kudumisha        | C. kuuimarisha       | D. kuusambaratisha         |
| 12. A. inayoiwezesha       | B. zinazoliwezesha  | C. zinazoiwezesha    | D. yanayoliwezesha         |
| 13. A. kawaida kama sheria | B. nzito kama nanga | C. lazima kama ibada | D. bure kama mkia wa mbuzi |
| 14. A. pamoja              | B. pasipo           | C. kwa               | D. na                      |
| 15. A. kuudunisha          | B. kudunisha        | C. kudumisha         | D. kuidumisha              |



**Kuanzia nambari 16 mpaka 30, jibu kila swali kulingana na maagizo.**

16. Chagua sentensi iliyo na kiwakilishi cha pekee.  
A. Mtoto huyu ni wangu, huyo ni wako.  
B. Kitabu kingine kitatumika kufanyia mazoezi.  
C. Embe zuri limeliwa ilhali baya limetupwa.  
D. Wengine watasafiri kwa ndege mpya.
17. Tambulisha kundi lililo na nomino za ngeli moja.  
A. Uyoga, ugali, uji, shauri.  
B. Vumbi, karai, uyoga, kaburi.  
C. Marashi, mate, mazingira, maziwa.  
D. Vyura, viroboto, vyerehani, vyanda.
18. Chagua sentensi ambayo imeakifishwa barabara.  
A. Niletee vitu hivi, kalamu, penseli na kitabu.  
B. Lo! sijapata kumwona mtu mcheshi kiasi hiki.  
C. Mzee Kazikwisha (kama anavyoitwa na wengi) ni kabwela.  
D. Mwalimu alifika shuleni, akaenda majilisini na akaketi?
19. Chagua sentensi inayoonyesha wakati uliopo hali isiyodhihirika.  
A. Kitwana analima shambani.  
B. Kitwana amelima shambani.  
C. Kitwana hulima shambani.  
D. Kitwana alima shambani.
20. **Unganisha sentensi hizi kwa usahihi.** Tuliivunja safari ya kwenda ughaibuni. Hali ya usalama haikuwa shwari.  
A. Tuliivunja safari ya kuenda ughaibuni licha ya hali ya usalama kutokuwa shwari.  
B. Tuliivunja safari ya kuenda ughaibuni madhali hali ya usalama haikuwa shwari.  
C. Tuliivunja safari ya kuenda ughaibuni minghairi ya hali ya usalama kutokuwa shwari.  
D. Tuliivunja safari ya kuenda ughaibuni ilhali hali ya usalama haikuwa shwari.
21. Maneno haya yatafuatana vipi kamusini?  
(i) Upelelezi (ii) Upekuzi  
(iii) Upembo (iv) Upembe  
A. (ii), (i), (iv), (iii)  
B. (i), (ii), (iv), (iii)  
C. (i), (iv), (iii), (ii)  
D. (ii), (iv), (iii), (ii)

22. **Kanusha:** Mtoto ambaye alisifiwa alifurahi.  
A. Mtoto ambaye hakusifiwa hakufurahi.  
B. Mtoto ambaye alisifiwa hajafurahi.  
C. Mzazi ambaye alikashifiwa alikasirika.  
D. Mtoto ambaye alisifiwa hakufurahi.
23. Chagua sentensi iliyo na maelezo sahihi.  
A. Mjumu ni fundi wa kufua dhahabu.  
B. Mtarijmani ni mtu anayetafsiri lugha moja kwa nyingine.  
C. Tarishi ni mtu anayetumwa kupeleka barua ya posa.  
D. Mhazigi ni fundi wa mitambo.
24. Chagua neno lenye herufi mwambatano.  
A. Maua                      B. Bahari  
C. Chai                      D. Mbao.
25. Chagua orodha iliyo na vivumishi pekee.  
A. Stadi, bora, wengi, sana.  
B. Kuliko, safi, ghali, kwa gari.  
C. Mwembamba, tamu, epesi.  
D. Gani, upesi, bora, safi.
26. **Tegua kitendawili kifuatacho.** Popoo mbili zavuka mto.  
A. Macho                      B. Miguu  
C. Ndege                      D. Mamba.
27. **Andika wingi wa sentensi hii.** Mtume ana godoro kubwa.  
A. Watume wana godoro kubwa.  
B. Mitume wana magodoro makubwa.  
C. Watume wana magodoro kubwa.  
D. Mitume ina magodoro makubwa.
28. Chagua sentensi iliyo na 'na' ya mtendaji  
A. Maria na Tamasha ni umbu.  
B. Gwiji ana matatizo tele.  
C. Nyanya alielekezwa na Juma.  
D. Wazazi wana mali nyingi.
29. **Andika kwa usemi wa taarifa.** "Nikijizatiti kabisa, nitafua dafu," Kaza alisema.  
A. Kaza alisema kuwa akijizatiti kabisa atafua dafu.  
B. Kaza alisema kuwa akijizatiti kabisa angefua dafu.  
C. Kaza alisema kuwa angejizatiti kabisa angefua dafu.  
D. Kaza alisema kuwa angejizatiti kabisa atafua dafu.
30. **Sentensi hii imetumia tamathali zipi za usemi?** Mwalimu wetu ni kamusi. Anatema Kiswahili kama mjuzi mwenyewe.  
A. Tashbihi, istiara  
B. Istiara, tashbihi  
C. Methali, istiara  
D. Nahau, tashbihi.



**Soma kifungu kifuatacho kisha ujibu maswali 31 - 40.**

Dunia haishi upya ingawa ya zamani. Hii ina maana kuwa ulimwengu hauishi mambo mapya kila wakati. Hatupaswi kushangaa tunapoyaona mambo mapya ulimwenguni. Binadamu amepiga hatua kubwa sana kuyaleta mabadiliko. Teknolojia imechangia pakubwa katika kuyafanikisha mabadiliko hayo. Maendeleo haya ya kiteknolojia yameufanya kuwa kama kijiji kidogo.

Teknolojia hii hii imechangia pakubwa katika kuyarahisisha maisha. Mawasiliano yamekuwa rahisi. Katika enzi za kisogoni, iwapo mtu alitaka kuufikisha ujumbe, alilazimika kuwatuma wajumbe. Aghalabu, makatikiro wangechelewa au kubadilisha ujumbe. Isitoshe, waliotuma barua, wangesuburi kikonzo. Mambo sasa yamekuwa mswaki. Kwa kutumia simu, unaweza kuwasiliana na mtu aliye mbali kwa urahisi.

Hapo zamani yalikuwa mazoea kusikia kuwa faili zimepotea hasa kortini. Hayo sasa yamezikwa katika kaburi la sahai. Ukitaka kupata habari kuhusu mtu au jambo fulani, utabofya tu jina kwenye tarakilishi. Maelezo yote yatajianika kwenye kiwambo cha runinga. Kule kuhangaika kubukua matopa ya faili na majadala kumeisha.

Hapo zamani, hasa mwisho wa mwezi, watu wangepiga foleni ndefundefu kupata huduma mbalimbali. Siku hizi mambo ni tofauti. Huduma za maji, umeme, benki na kadhalika hulipiwa kupitia kwenye simu. Huduma za pesa kama vile M-PESA zimefanya maisha kuwa mswaki. Unaweza kulipia huduma yoyote wakati wowote ukiwa mahali popote. Raha iliyoje!

Mbali na hayo, masomo ya mtandaoni yameinua na kuimarisha elimu nchini. Mradi uwe na kompyuta iliyounganishwa kwenye mtandao, unaweza kuendeleza masomo. Si lazima uende shuleni wala darasani. Aidha, mtu husoma kwa raha zake wakati wowote anaotaka. Watu wengi wamepata diploma na shahada wakiwa nyumbani au hata ofisini. Hakuna kutoa visingizio kuwa huna wakati wa kusoma, la hashu! Yeyote mwenye nia ya kusoma, anaweza kusoma bila udhia.

Teknolojia ndiyo njia. Hakuna kupoteza wakati tena. Wananchi wanapata fursa ya kufanya shughuli nyingine muhimu za ujenzi wa taifa. Kupitia kwa teknolojia unaweza kununua bidhaa au kuagiza huduma yoyote kupitia kwenye simu. Je, umeyasikia magari ya teksi yanayoitwa UBER? Ukitaka kwenda popote, unaliagiza kwa simu na kulipia kwa simu.

Hata hivyo, **hakuna bamvua lisilo na usubi.** Licha ya manufaa yanayotokana na teknolojia, ina madhara pia. Awali ya yote, imezorotesha pakubwa maadili katika jamii. Vijana wamepotoka maadamu wanayaiga kikasuku mabaya na maovu wanayoyaona mtandaoni. Mitindo ya kisasa ya mavazi ni ya aibu na ya kumtapisha hata nguruwe! Mazungumzo nayo hayana tasfida hata chembe yanakirihisha ajabu.

Fauka ya hayo, vijana wamepevuka katika mambo yasiyolingana na umri wao. Wanayajua masuala ya mapenzi katika umri usiofaa. Hili limechangia katika kujitosa katika bahari ya mapenzi wakiwa wachanga mno. Waama, teknolojia **imebwaga zani** duniani.

Isitoshe, teknolojia imeeneza uzembe na uzohali miongoni mwa watu. Baadhi ya watu hutumia muda wao mwingi kwenye mitandao ya kijamii mathalan: Facebook, Twita, Whatsup na Instagramu. Ofisini badala ya kuchapa kazi, watu huzama mitandaoni. Wanafunzi badala ya kusoma, wanapendelea kucheza michezo mitandaoni. Hali ikiendelea hivi dunia itageuka kuwa ulimwengu wa wazembe.

**Teknolojia ni kama upanga wenye makali pande mbili.** Ikitumiwa vibaya itatuhasiri na kutudhuru. Hata hivyo, ikitumiwa vyema na kwa tahadhari, itatunufaisha na kutufaidi pakubwa. Tuwe waangalifu la sivyo maarifa yetu ndiyo yatakayotuangamiza. Kumbuka, akili ya mtu ndiyo wazimu wake.



31. Kulingana na aya ya kwanza  
 A. duniani hakuna mambo mapya ni yale ya zamani tu ambayo hujirudia  
 B. ulimwengu umekuwa kijiji kidogo sana  
 C. teknolojia imefanya ulimwengu kuwa mithili ya kijiji kidogo sana  
 D. binadamu ameshindwa kufanya mengi katika teknolojia.
32. **'Hakuna bamvua lisilo na usubi.'**  
 Ni methali ipi kati ya hizi isiyolingana sawasawa na hii?  
 A. Hakuna refu lisilokuwa na ncha.  
 B. Hakuna masika yasiyokuwa na mbu.  
 C. Hakuna gurufu isiyokuwa na gurufa.  
 D. Hakuna msiba usio na mwenziwe.
33. Teknolojia imesaidia katika mambo haya yote ila  
 A. kurahisisha ulipaji wa huduma mbalimbali  
 B. kuinua kiwango cha masomo katika nchi  
 C. kufanya watu kuwa wavivu duniani  
 D. kuboresha mawasiliano.
34. Ni kauli ipi hapa isiyokuwa sahihi kulingana na aya ya pili?  
 A. Teknolojia ndiyo njia pekee tu ambayo imeyarahisisha maisha.  
 B. Maisha yamerahisishwa kwa njia kubwa kupitia kwa teknolojia.  
 C. Kupitia kwa teknolojia imekuwa rahisi kuwasiliana na watu walio mbali.  
 D. Teknolojia imesaidia kuwasilisha ujumbe jinsi unavyokusudiwa.
35. Ni nini maana ya maneno **bwaga zani** kama yalivyotumika katika kifungu?  
 A. Leta shida.  
 B. Sababisha faida.  
 C. Ongeza manufaa.  
 D. Ghilibu watu.
36. Ni akina nani hasa walioathiriwa pakubwa na teknolojia kulingana na kifungu?  
 A. Watu wa hirimu zote.  
 B. Vijana.  
 C. Wanaotumia teknolojia.  
 D. Watu wote.
37. Kulingana na aya ya tano  
 A. hakuna haja ya kwenda kusomea shuleni  
 B. mtu yeyote sasa anaweza kusoma kwa udhia  
 C. yeyote aliye na hamu ya kusoma anayo nafasi nzuri ya kufanya hivyo  
 D. katika kame hii ya teknolojia hakuna mtu yeyote anayeenda madararani.
38. Mtazamo wa mwandishi kuhusu teknolojia ni kuwa  
 A. teknolojia inafaa kukoma kutumika kutokana na madhara yake  
 B. teknolojia ina faida nyingi na madhara yake yanafaa kupuuzwa  
 C. maisha hayawezi kamwe kuendelea bila ya kuwapo kwa teknolojia  
 D. licha ya kuwa na manufaa, teknolojia inafaa kutumiwa kwa makini sana.
39. **'Teknolojia ni kama upanga wenye makali pande mbili.'**  
 Je, kauli hii ina maana gani kulingana na kifungu?  
 A. Teknolojia ni kali na butu pia.  
 B. Teknolojia ina manufaa na madhara pia.  
 C. Teknolojia ina hasara nyingi sana.  
 D. Teknolojia ina faida nyingi sana.
40. Kichwa mwafaka zaidi kwa taarifa hii ni kipi?  
 A. Madhara ya teknolojia.  
 B. Mabadiliko duniani.  
 C. Faida za teknolojia.  
 D. Teknolojia



**Soma kifungu kifuatacho kisha ujibu maswali 41-50.**

Hivi majuzi vyombo vya habari viliibuka na kituko cha kuvunja mbavu. Ghulamu mmoja alijitokeza kazaliwa upya kageuka msichana! Sauti yake nyororo ya kike ilisikika kwa kuwatia wengi taharuki. Kijana huyu alikuwa akifanya kazi kama kijakazi katika familia mbalimbali. Waajiri wake waliokuwa siku hizo zote wakidhani kuwa ni banati, **walimwacha kutumia chumba kimoja na wenzake.**

Ujanja wa 'kipusa' wetu ulipogunduliwa, hakuonekana **kupigwa na mshipa.** Kelele za watu waliokuwa wakitaka kumrambisha shubiri zilionekana kwake kama mkoromo wa chura ambao haumzui ng'ombe kukata kiu yake. Cheche zote za matusi kutoka kwa waja ziliangukia masikio yenye nta kwani 'banati' huyu ambaye alikuwa kajitanda buibui kama kawaida ya jumuiya yake, alishikilia kuwa alikuwa na haki ya kufanya alitakalo. Yamkini hakujua kuwa haki nayo ina mipaka.

Waajiri wengine hasa akina mama, walihadithia jinsi walivyomwamini kijakazi huyu mnyenyekevu kiasi cha kuachia chui mbuzi. Mmoja wao alisikika akilalamika kwamba 'msichana' huyu, kwa jina Mzaha alikuwa amewaathiri wanawe wa kike vibaya kwa kuwashawishi wasiende shule. Aliwaelekeza watoto hawa kwa wanaume ambao alisema wangewapa pesa. Ingawa haikubainika kama kweli wana hawa walipelekwa 'mawindoni' hili ni wazo la kutisha na kuhuzunisha sana.

Watazamaji wengi wa runinga bila shaka walikilaani kitendo hicho. Hata hivyo, jambo la kujiuliza ni je, kwa nini mvulana huyu akataka kuwa msichana bandia?

Visa vingi vya uhalifu na maovu ya kijamii vimetokea kwa sababu mbalimbali. Baadhi ya vijana wanadai kwamba kwa sababu ya uhaba wa kazi, hawana budi kufanya kazi yoyote ile, almuradi wapate riziki, japo ya siku moja. Huyu aliamua kuwa 'mjakazi' ili apate kazi katika nyumba za watu ambako ana hakika ya kupata mahitaji ya msingi kama vile malazi na chakula.

Ukosefu wa mawasiliano kati ya wazazi na wanawe huenda ukawa chanzo mojawapo ya matatizo ya watoto. Migogoro itokeapo, baadhi ya vijana huhiari kutorokea mijini na kufikwa na ya kuwafika.

Ni kweli kwamba jamii yetu imelemazwa na umaskini uliokithiri. Hata hivyo, hatupaswi kuchukulia maadili ya kijamii kuwa jambo la mzaha. Maisha si kuendeleza ulaghai kama shamsa na wengine wengi wanapaswa kukumbuka kuwa **tatizo halitatuliwi kwa tatizo lingine.** kwani kwa kufanya hivyo watajiingiza kwenye mafundo ambayo hawawezi kujitanzua kwayo. Vijana wahimizwe kujiunga na makundi kama yale ya kuzoa taka mjini ili kujiepusha na uhalifu. Wanaohitimu darasa la nane na kushindwa kuendelea na elimu wafunzwe kazi za kiufundi ili waweze kujiunga na sekta ya jua kali. Kwa njia hii, wataweza kujikimu na kuzikimu aila zao. Shime! Tuhimize maadili.



41. Tukio linalorejelewa hapa limetajwa kuwa la  
 A. kushangaza  
 B. kuchekecha  
 C. kuudhi  
 D. kutisha.
42. 'Walimwacha kutumia chumba kimoja na wenzake'. Maana yake ni kuwa  
 A. kijakazi alitumia chumba na jamaa wengine wa familia  
 B. mvulana huyo alitumia chumba na jamaa wengine wa familia  
 C. kijakazi alitumia chumba kimoja pamoja na wasichana katika familia  
 D. kijakazi aliogopa kugunduliwa.
43. Semi kupigwa na mshipa kulingana na kifungu ina maana kuwa  
 A. hakuonekana kujali  
 B. alionekana kushtuka  
 C. hakuogopa kugunduliwa  
 D. aliononeka zaidi.
44. 'Kijakazi' hakuyajuti matendo yake kwa sababu  
 A. alisadiki kuwa na uhuru wa kutenda atakalo  
 B. waajiri wake walijitokeza kumtetea vikali  
 C. alielewa kuwa hakumkosea mtu yeyote  
 D. alikuwa ameinukia kupendwa na wengi.
45. Ni wazi kuwa 'msichana' huyu aliwapotosha mabinti wa mwajiri wake kwa  
 A. kuwadhulumu kimapenzi walipokuwa pamoja  
 B. kuwapeleka kwa wanaume waliowapotosha kitabia  
 C. kuwarubuni wayakaidi masomo yao  
 D. kuwatorosha nyumbani wakatafute pesa.
46. Habari za tukio hili zilienezwa zaidi na  
 A. waajiri wake aliowalaghai  
 B. majirani waliolishuhudia tukio hilo  
 C. marafiki zake waliomwona wakamtambua  
 D. vyombo vya habari vilivyotangaza habari hizo.
47. Kwa kawaida, mjakazi ni nani?  
 A. Mfanyakazi wa kike nyumbani.  
 B. Mfanyakazi wa kiume nyumbani.  
 C. Mtu mwenye ujuzi mwingi wa kufanya kazi.  
 D. Mtu ambaye hawezi kuaminika.
48. Chanzo kikuu cha migogoro katika jamii hasa miongoni mwa vijana ni  
 A. matumizi ya mihadarati  
 B. ukosefu wa ajira  
 C. kukosa maelekezo kwa wafanyakazi  
 D. kupotoshwa na kuadilika.
49. Mwandishi ana maana gani anaposema kuwa 'tatizo halitatuliwi kwa tatizo lingine'?  
 A. Mambo hayatengenezwi kwa kuchukua hatua zisizofaa.  
 B. Usilitatue tatizo baada ya jingine kuzuka.  
 C. Usisuluhishe shida moja ukaipuuza nyingine.  
 D. Matatizo yanapotupata tusijaribu kuyakwepa.
50. Kichwa mwafaka zaidi kwa makala haya ni  
 A. Tukio la kupongezwa.  
 B. Msichana aliyewashangaza wengi.  
 C. Matokeo ya ukarimu katika jamii.  
 D. Maadili katika jamii.



# STANDARD EIGHT

K.C.P.E REFLECTOR

K.C.P.E REFLECTOR

**KISWAHILI**

**SEHEMU B**

**INSHA**





**Umepewa dakika 40 kuandika insha yako.**

**Andika insha isiyopungua ukurasa mmoja na nusu ukifuata maagizo uliyopewa.**

**Ufuatao ni mwanzo wa insha. Iendeleze kwa maneno yako mwenyewe huku ukiifanya kuwa ya kisisimua.**

*Ama kwa hakika, atafutaye hachoki na akichoka keshapata. Chudi alifahamu ukweli wa msemo huu siku moja alipokuwa.....*



A series of approximately 25 horizontal black lines spanning the width of the page, intended for writing or drawing.



# STANDARD EIGHT

## K.C.P.E REFLECTOR

### SCIENCE

Time: 1hr 40mins

#### **INSTRUCTIONS TO CANDIDATES (Please read these instructions carefully)**

1. You have been given this question booklet and a separate answer sheet. The question booklet contains 50 questions.
2. Do any necessary rough work in this booklet.
3. When you have chosen your answer, mark it on the **ANSWER SHEET**, not in the question booklet.

#### **HOW TO USE THE ANSWER SHEET**

4. Use an ordinary pencil.
5. Make sure that you have written on the answer sheet:
 

**YOUR INDEX NUMBER**  
**YOUR NAME**  
**NAME OF YOUR SCHOOL**
6. By drawing a **dark line** inside the correct numbered boxes mark your full Index Number (i.e. School code Number and the three-figure Candidate's Number) in the grid near the top of the answer sheet.
7. Do not make any marks outside the boxes.
8. Keep your answer sheet as clean as possible and do not fold it.
9. For each of the Questions 1 – 50, four answers are given. The answers are lettered A, B, C, and D. In each case only **ONE** of the four answers is correct. Choose the correct answer.
10. On the answer sheet the correct answer is to be shown by drawing a **dark line** inside the box in which the letter you have chosen is written.

#### **Example**

**In the question booklet:**

4. The type of teeth used in crushing food
  - A. have one root
  - B. are chisel-shaped
  - C. cut and bite food
  - D. have uneven tops.

The correct answer is **D (have uneven tops)**

**On the answer sheet:**

**4.** [A] [B] [C] **■** [D]    **14.** [A] [B] [C] [D]    **24.** [A] [B] [C] [D]    **34.** [A] [B] [C] [D]    **44.** [A] [B] [C] [D]

In the set of boxes numbered 4, the box with the letter D printed in it is marked.

11. Your **dark line** **MUST** be within the box.

**TURN OVER**



- Which one of the following animals does **not** have mammary glands?
  - Whale
  - Shark
  - Bat
  - Spiny Ant Eater
- The function of a fibre in the diet is to help in
  - absorption of digested food.
  - getting rid of undigested food
  - adding nutrients to the body
  - digestion of food.
- During a Science practical lesson pupils collected the following materials.
  - Glass bottle
  - Ink
  - Water
  - Source of heat
  - Narrow transparent tube.
 The aspect of heat they were **most** likely to investigate was
  - expansion in liquids
  - air occupying space
  - contraction of air
  - contraction of liquids.
- Which of the following is **not** a sign of an ill health in plants?
  - Reduced yields.
  - Curled leaves.
  - Stunted growth.
  - Wilting.
- The following are immunizable diseases. Which one is **not**?
  - Tuberculosis
  - Malaria
  - Poliomyelitis
  - Tetanus.

- When the arrow head of a wind vane points to the South, it shows that the wind is blowing from
  - North
  - West
  - East
  - South.
- Which of the following bottles will produce the loudest sound when hit with a metal rod?

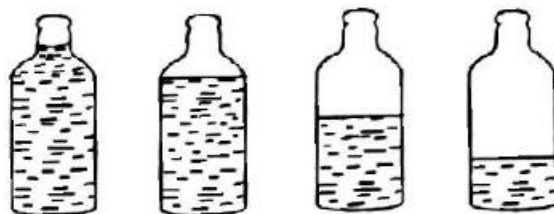

D

Q

R

S

- Q
  - S
  - D
  - R
- Which of the following pairs consists of parts of the human digestive system where absorption takes place?
    - Ileum and liver.
    - Stomach and mouth
    - Colon and ileum.
    - Duodenum and liver.
  - When dealing with with electricity, the following activities can cause shock **except**
    - touching switches with wet hands
    - overloading sockets
    - repairing appliances when plucked in sockets
    - touching naked wires.



10. The following are symptoms of water borne diseases.

- (i) Pain in the joints.
- (ii) Itching in lower abdomen.
- (iii) Blood stained stool.
- (iv) Severe diarrhoea and vomiting.

Which of the above symptoms are for bilharzia?

- A. (i) and (iv)
- B. (ii) and (iv)
- C. (i) and (iii)
- D. (ii) and (iii)

11. The illustration below shows how matter can change from one form to another.

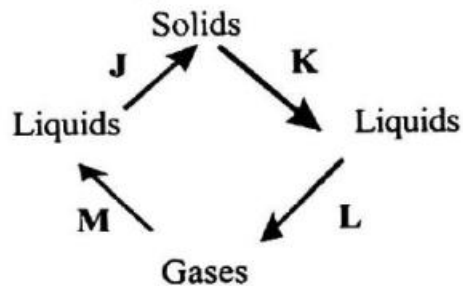

Which pair of processes shown above requires an increase in temperature?

- A. J and K
- B. K and L
- C. L and M
- D. M and J

12. When investigating factors affecting floating and sinking, standard 4 pupils placed a bottle top on water in a basin. They made the same bottle top into a ball and placed it on the water. The factor they were investigating was

- A. shape
- B. type of material
- C. mass
- D. size.

13. Which one of the following statements is **true** about friction? Friction

- A. is reduced by treading
- B. acts on the opposite direction
- C. is a pull or a push on an object
- D. is useful in swimming.

14. The diagram below represents a type of a lever when in use.

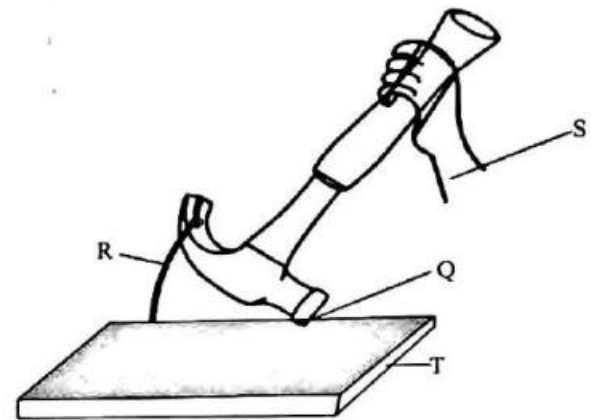

The position of the fulcrum is shown by the part labelled

- A. T
- B. Q
- C. S
- D. R

15. Which one of the following pairs consists of grazing methods that can be used in controlling hookworms and mites?

- A. Tethering and herding.
- B. Herding and stall feeding.
- C. Paddocking and strip grazing.
- D. Strip grazing and zero grazing.



16. The illustration below shows classification of plants.

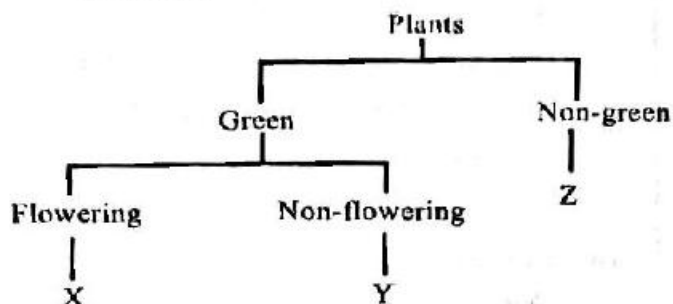

Which of the following correctly shows example of each of the group as shown in the illustration?

X	Y	Z
A. Maize	Fern	Cactus
B. Beans	Algae	Toadstool
C. Cactus	Acacia	Mushroom
D. Banana	Cactus	Puffballs

17. Carnivores mammals have well developed canine teeth suitable for
- holding and chewing prey
  - cutting and tearing prey
  - holding and tearing prey
  - chewing and cutting prey.

18. The diagram below shows an electric tube that is using a car battery to light.

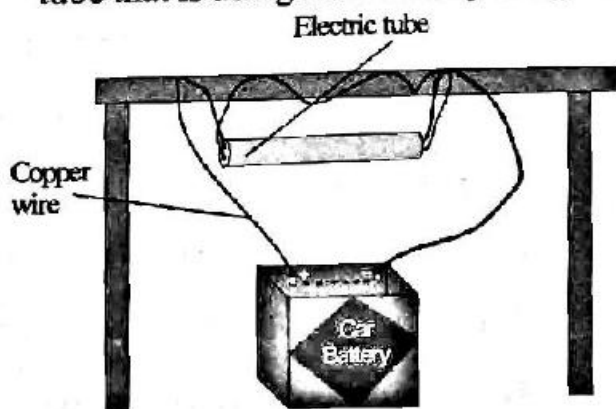

The energy transformation that is taking place is

- Chemical → light → heat → electrical
  - Chemical → electrical → heat → light
  - Heat → chemical → electrical → light
  - Chemical → electrical → light → heat
19. Which one of the following statements about states of matter is **not** correct?
- Water vapour has definite volume and mass.
  - Solids have definite mass and volume.
  - Liquids take the shape of the container.
  - All states of matter occupy space.
20. Which one of the following is an effect of HIV and AIDS to the family?
- Poor health.
  - Embarrassment.
  - Congestion in hospitals.
  - Low self esteem.
21. Below is a pie chart that shows composition of air.

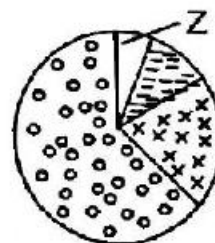

Which one the following is **not** a function of the part of the air labelled Z?

- Supporting burning.
- Making plant food.
- Preserving soft drinks.
- Putting out fire.



22. The following are tool maintenance practices.

- (i) Sharpening
- (ii) Proper storage
- (iii) Repairing
- (iv) Proper use.

Which pair consists of practices done for efficiency?

- A. (ii) and (iv)
- B. (i) and (ii)
- C. (i) and (iii)
- D. (ii) and (iii)

23. The word 'Reason' was written on a paper and then placed in front of a mirror as shown below.

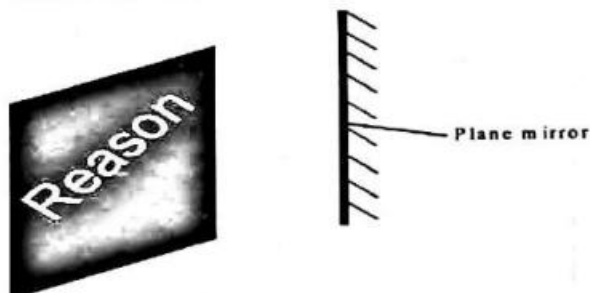

The aspect of light being investigated was

- A. making shadows
- B. dispersion
- C. refraction
- D. reflection.

24. Which of the following methods of soil conservation can be used effectively to control the type of erosion shown below?



- A. Mulching
- B. Contour farming
- C. Terracing
- D. Building gabions.

25. When investigating a certain property of matter, standard 5 pupils inverted an empty glass in a basin containing water. Which property of matter were they investigating?

- A. Air expands on heating.
- B. Air exerts pressure.
- C. Air occupies space.
- D. Air has mass.

26. Which one of the following lists consists of magnetic materials only?

- A. Steel, iron, rubber.
- B. Aluminium, iron, silver coin.
- C. Nail, glass, copper.
- D. Staple pins, iron, steel.

27. Plants provide other plants with

- A. support and food
- B. habitat and shade
- C. water and habitat
- D. shade and carbon dioxide.

28. The **main** reason for undertaking pre-test counselling during HIV testing is to

- A. positively accept the results
- B. help change the behaviour
- C. take the test without fear
- D. get advice on medication if one is infected.

29. When pupils mixed garden soil with water, they observed bubbles rising up. The observations made indicated the presence of

- A. organisms in soil
- B. water in soil
- C. humus in soil
- D. air in soil.



30. Which one of the following is a way in which water is conserved by using it sparingly?

- A. Treating dirty water.
- B. Using drip irrigation method.
- C. Harvesting rain water.
- D. Storing water in big dams.

31. Which one of the following pairs consists of foods taken to repair body parts?

- A. Chicken and beans.
- B. Maize and bread.
- C. Fish and ripe banana.
- D. Carrots and kales.

32. Study the food chain below.

Maize → Chicken → Mongoose → Hyena

Which of the above feeding organisms will belong to the same group as a cat?

- A. Maize
- B. Chicken
- C. Mongoose
- D. Hyena.

33. The best way of managing domestic wastes is by

- A. recycling them
- B. turning them into a compost manure
- C. burning them
- D. re-using them.

34. When hard water is mixed with soap it forms

- A. lather
- B. scum
- C. scale
- D. fur.

35. The diagram below represents a set-up that was used to investigate good and poor conductors of electricity.

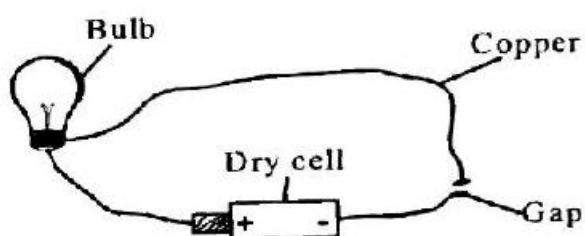

Which one of the following materials when placed at the gap will **not** make the bulb to light?

- A. Iron rod
- B. Rubber
- C. Aluminium foil
- D. Nail

36. Which one of the following shows the correct order of flow of urine from the kidney?

- A. Bladder → ureter → urethra.
- B. Urethra → ureter → bladder.
- C. Ureter → urethra → bladder.
- D. Ureter → bladder → urethra.

37. To increase the rate of decomposition of the components inside a compost manure heap one should

- A. moisten the heap
- B. add wooden ash to the heap
- C. add farm yard manure to the heap
- D. turn the components regularly.





38. Which one of the following parts of the flower have been **correctly** matched to its function?

- A. Petals - Protecting the flower when at bud stage.
- B. Style - Giving space for pollen tube to grow.
- C. Filament - Producing reproductive cell.
- D. Ovary - Becoming seedling after fertilization.

39. The diagram shown below represents a weather instrument that was improvised by standard 5 pupils.

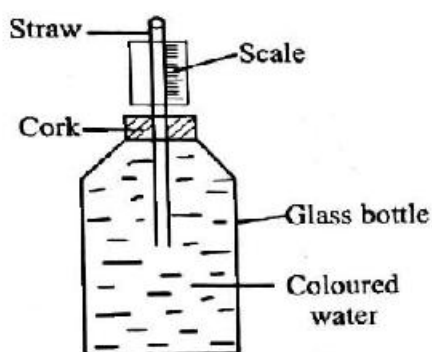

The pupils used a long narrow tube **mainly** to

- A. make the water expand uniformly
- B. record small temperature changes
- C. make the bottle neck to contract
- D. increase visibility.

40. The following are effects of drug abuse.

Which one is a health effect?

- A. Drug induced accidents.
- B. Loss of income.
- C. Impaired judgement.
- D. Truancy.

41. Which one of the following blood components has been **wrongly** matched to its function in the human body?

- A. Plasma - Transportation of digested food.
- B. Red blood cells - Transportation of oxygen to the body.
- C. White blood cells - Preventing entry of germs into the body.
- D. Platelets - Clotting of blood.

42. Which one of the following statements is **correct** about pollution of the environment?

- A. Oil spillage pollutes water only.
- B. Treated sewage pollutes water.
- C. The main air pollutants are industrial gases.
- D. Farm chemical pollutes only soil.

43. During the process of birth, as soon as the amnion sac breaks

- A. the cervix widens
- B. the baby comes out
- C. there is contraction of uterine walls
- D. the after birth comes out.

44. The **main** value of breast milk is that the milk

- A. is easily digested
- B. is balanced in nature
- C. contains natural immunity
- D. has no chemicals.



45. A single fixed pull makes work easier by
- increasing the load distance
  - reducing the slopes
  - increasing the effort distance
  - changing the direction of force.

46. Which one of the following uses of water is recreational?
- Swimming
  - Cleaning tools
  - Washing clothes
  - Cleaning bottles.

47. Which one of the following methods of separating mixtures is **wrongly** matched with the kind of mixtures it separates?

Method	Mixture
A. Picking	A mixture of big solid particles.
B. Winnowing	A mixture of light and heavy solid materials.
C. Sieving	A mixture of small and large particles.
D. Using magnet	A mixture of magnetic materials.

48. The pull or push of an object can best be defined as
- mass
  - friction
  - force
  - weight.

49. Which one of the following characteristic of clouds of clouds is wrongly matched?

Nimbus	Cumulus
A. Irregular in shape.	Mountaneous in shape.
B. Dark grey in colour.	White in colour.
C. Spread in flat layers.	Cover the whole sky.
D. Found low in sky.	Found high in the sky.

50. The diagram below represents a set-up that was used to demonstrate a certain aspect of heat.

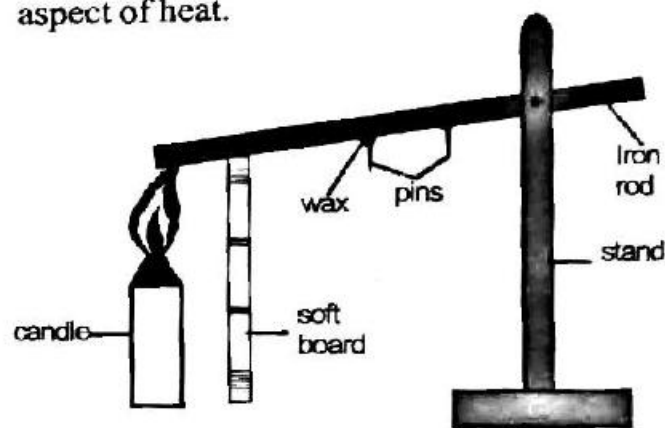

The aspect of heat investigated was

- conduction only
- conduction and convection
- conduction and radiation.
- convection and radiation.



# STANDARD EIGHT

## K.C.P.E REFLECTOR

### SOCIAL STUDIES AND RELIGIOUS EDUCATION

Time: 2 hours 15 minutes

#### INSTRUCTIONS TO CANDIDATES (Please read these instructions carefully)

1. You have been given this question booklet and a separate answer sheet. The question booklet contains 90 questions.
2. When you have chosen your answer, mark it on the ANSWER SHEET, not in the question booklet.
3. Use an ordinary pencil.
4. Make sure that you have written on the answer sheet:  
**YOUR INDEX NUMBER**  
**YOUR NAME**  
**NAME OF YOUR SCHOOL**
5. By drawing a **dark line** inside the correct numbered boxes mark your full Index Number (i.e. School Code Number and the three-figure Candidate's Number) in the grid near the top of the answer sheet.
6. Do not make any marks outside the boxes.
7. Keep your answer sheet as clean as possible and do not fold it.
8. For each of the questions 1 – 90, four answers are given. The answers are lettered A, B, C and D. In each case only **ONE** of the four answers is correct. Choose the correct answer.
9. On the answer sheet the correct answer is to be shown by drawing a **dark line** inside the box in which the letter you have chosen is written.

#### **Example**

##### **In the question booklet:**

33. The property that a person receives from someone who has died is called

- A. succession
- B. will
- C. wealth
- D. inheritance.

The correct answer is "D"(inheritance)

##### **On the answer sheet:**

**31** | A | B | C | D    **32** | A | B | C | D    **33** | A | B | C | **D**    **34** | A | B | C | D |    **35** | A | B | C | D

In the set of boxes numbered 33, the box with the letter D printed in it is marked.

10. Your **dark line** **MUST** be within the box.
11. For each question **ONLY ONE** box is to be marked in each set of four boxes.

**TURN OVER**

# MASA AREA

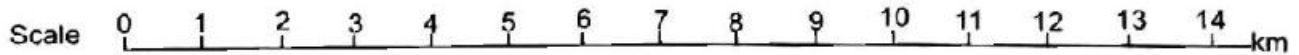
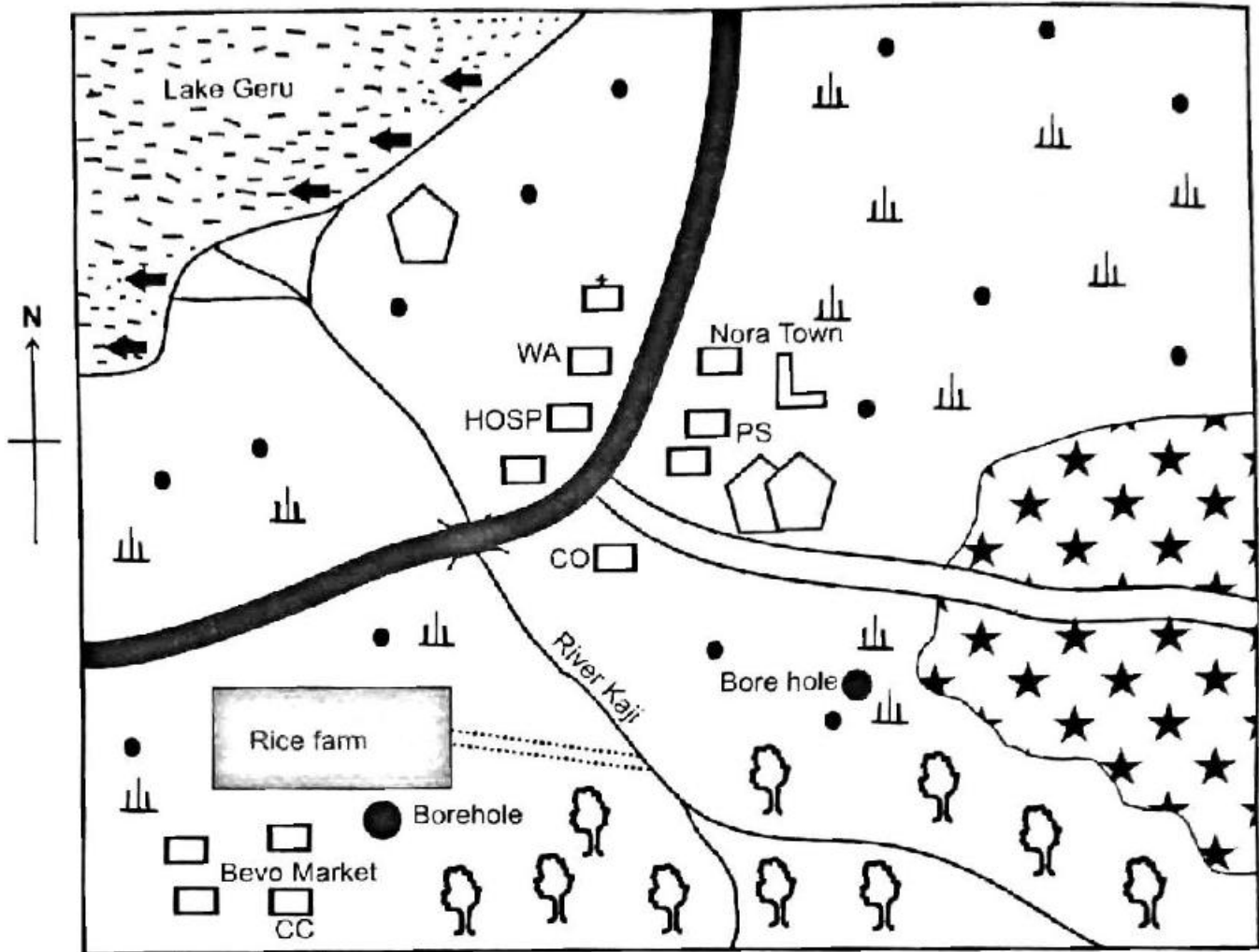

## KEY

	Tarmac road	C C	Chief's camp		Scrub
	Forest		School		River and bridge
	Permanent Buildings	WA	Ward Administrator		Sisal factory
	Murram road	HOSP	Hospital		Church
	Settlement	C.O	County offices		Fish factory
	Fishing Areas		Sisal farm	PO	Police station

Study the map of Masa Area and answer questions 1 - 7.

1. The land in Masa area generally slopes towards
  - A. North West
  - B. South West
  - C. North East
  - D. South East
2. The approximate area of the sisal farm in Masa area is
  - A. 17km<sup>2</sup>
  - B. 14km<sup>2</sup>
  - C. 21km<sup>2</sup>
  - D. 19km<sup>2</sup>
3. Traders living in Masa area can obtain trade licenses from the
  - A. chief
  - B. police
  - C. county office
  - D. Ward administrator.
4. Three of the following statements about lake Geru are **true**. Which one is not?
  - A. It is used for irrigation.
  - B. It is an inland drainage system.
  - C. It is a source of income.
  - D. It is the mouth of R. Kaji.
5. The fish factory was built **mainly** due to
  - A. nearness to a tarmac road
  - B. nearness to Nora town
  - C. availability of labour in the area.
  - D. nearness to the source of fish.
6. Which one of the following indicates that Masa area is found in dry areas?
  - A. Presence of a lake.
  - B. Growing of sisal.
  - C. Presence of a river.
  - D. Growing of rice.
7. Which one of the following economic activities is **not** carried out in Masa area?
  - A. Lumbering
  - B. Crop growing
  - C. Fishing
  - D. Trading.
8. Which one of the following communities is a Voltaic speaker?
  - A. Mossi
  - B. Kanuri
  - C. Nupe
  - D. Tukolor.
9. Below are descriptions of population.
  - (i) *Most people depend on farming.*
  - (ii) *Most people are over forty years.*
  - (iii) *Dependance rate is high.*
  - (iv) *Most people live in towns.*
  - (v) *Population growth rate is low.*Which group of facts **correctly** describes the population of Germany?
  - A. (i), (ii), (iii)
  - B. (i), (iii), (v)
  - C. (ii), (iii), (iv)
  - D. (ii), (iv), (v)
10. Which one of the following is the **largest** island in Africa?
  - A. Seychelles
  - B. Cape Verde
  - C. Madagascar
  - D. Sao Tome and Principe.
11. The school management committee ensures good learning environment for pupils by
  - A. employing good teachers in a school
  - B. paying teachers well
  - C. buying good books for a school
  - D. implementing building of good classrooms.

12. Canal method of irrigation is used in Mwea irrigation scheme because  
 A. the land slopes gently  
 B. the method saves water  
 C. water does not evaporate quickly  
 D. rivers in the area have plenty of water.

13. Which one of the following countries is **mainly** occupied by planted forests in Africa?  
 A. South Africa  
 B. Kenya  
 C. Swaziland  
 D. D.R.Congo.

14. Areas that have plains influence human activities **mainly** through  
 A. serious soil erosion  
 B. disruption of settlements by flooding  
 C. presence of tsetse flies  
 D. hinderance to transport due to steep slopes.

Use the map of Eastern Africa below to answer questions 15 to 18.

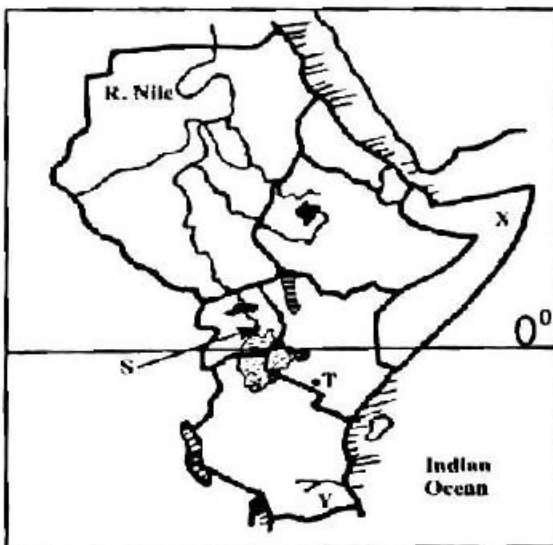

15. The area marked X is sparsely populated due to  
 A. presence of tsetse flies  
 B. poor roads in the area  
 C. low rainfall in the area  
 D. frequent flooding in the area.

16. Before the colonial, period the community that lived in the shaded area marked S was ruled by  
 A. chiefs  
 B. kings  
 C. council of elders  
 D. warriors.

17. The river marked Y is  
 A. R. Ruvuma  
 B. R. Pangani  
 C. R. Malagarasi  
 D. R. Rufiji.

18. The pre-historic site marked T is  
 A. Olorgesailie  
 B. Fort Ternan  
 C. Kariadusi  
 D. Koobi Fora.

19. The **main** benefit of foreign trade to the economy of Kenya is that  
 A. it has led to good international relations  
 B. it has led to decrease in taxes  
 C. it earns foreign exchange  
 D. people are able to exchange cultures.

20. Who among the following African leaders is **correctly** matched with the area he represented in the legislative council in 1957?

Leader	Area
A. James Muimi	Nairobi
B. Ronald Ngala	Coast
C. Tom Mboya	Rift valley
D. Daniel Arap Moi	Ukambani

21. An example of a processing industry in Kenya is  
 A. leather tanning  
 B. steel rolling  
 C. hotel  
 D. vehicle assembling.

22. Below is a description of a certain type of soil.

- (i) It has fine particles.
- (ii) It becomes water logged when it rains.
- (iii) It is good for cotton growing.

The type of soil described above is

- A. loam soil
- B. sandy soil
- C. volcanic soil
- D. clay soil.

23. Below is a description about a certain hominid during the evolution of human beings.

- (i) He discovered fire.
- (ii) He used speech to communicate.
- (iii) He made hunting tools from stone.

The hominid described above is

- A. Homo erectus
- B. Homo sapien
- C. Homo sapien sapien
- D. Homo habilis.

24. The **main** objective of forming the African union (AU) in 2002 was to

- A. establish similar government system
- B. achieve greater unity in Africa
- C. promote the use of Kiswahili
- D. organize armed struggle for independence.

25. A cultural attraction that promotes tourism in Kenya is

- A. Fort Jesus
- B. wildbeest migration
- C. traditional dances
- D. Gedi ruins.

26. The **main** benefit of horticultural farming in Kenya is that it

- A. has brought dry lands into use
- B. has led to improvement in infrastructure
- C. has promoted rural to urban migration
- D. creates income for farmers.

Use the diagram below to answer question

27.

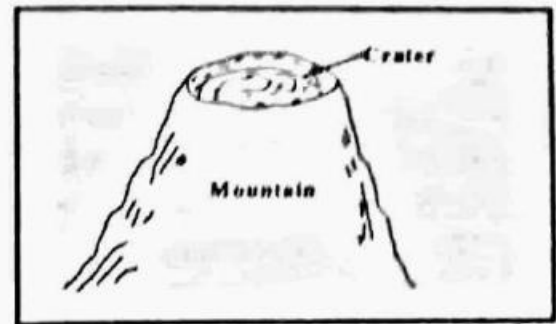

27. Which one of the following mountains in Eastern Africa was formed through the process shown above?

- A. Mt. Ruwenzori
- B. Mt. Meru
- C. Mt. Usambara
- D. Mt. Pare.

28. Which one of the following is a responsibility of children in a family?

- A. Taking care of family property.
- B. Providing basic needs.
- C. Paying their school fees.
- D. Establishing business opportunities.

29. Which one of the following factors has **mainly** contributed to decrease in life expectancy in Kenya?

- A. Early marriages.
- B. Improvements in health care.
- C. HIV and AIDS infections.
- D. Use of family planning methods.

30. Which one of the following is **not** a characteristic of traditional crop farming?

- A. Land was individually owned.
- B. It was mainly for subsistence.
- C. Mixed cropping was practised.
- D. It mainly depended on family labour.

31. Migration of many people to urban areas has led to

- A. destruction to natural forests
- B. establishment of informal settlements
- C. increase in jobs in towns
- D. increase in agricultural production.

32. The **main** reason why fish farming in Japan is more developed than in Kenya is
- fishermen in Japan are financially supported by the government
  - fish are locally consumed in Japan
  - presence of well managed cooperatives
  - availability of large market.
33. One of the sources of revenue for county governments in Kenya is
- court fees
  - issuing of trade licenses
  - sales from bonds and treasury bills
  - profits from parastatals.
34. Which of the following effects is caused by deforestation?
- Increase in forest cover.
  - Siltation in dams.
  - Increase in timber export.
  - Increase in agricultural production.
35. The collaboration between Oloibon Lenana and the British in Kenya during the colonial period led to
- Maasai youth joining the British colony
  - acquisition of cattle by the Maasai
  - loss of Maasai land to white settlers
  - Maasai acquiring new crops.
36. Below is a description of a certain town in Kenya.
- It handles most Kenya's foreign trade.*
  - It was started by the early Arabs.*
  - It has a petroleum refinery.*
- The town described above is
- Nairobi
  - Kisumu
  - Eldoret
  - Mombasa.

37. Below are conditions necessary for the growing of a certain crop.
- Temperatures of about 18°C.*
  - Annual rainfall of 450mm - 550ml.*
  - Black cotton soil.*
  - Dry sunny period during harvesting.*
- The crop that grows under the conditions above is
- wheat
  - tea
  - cocoa
  - cotton.
38. Establishment of settlement schemes in Kenya after 1963 led to
- acquisition of land by landless Africans
  - loss of African land to white settlers
  - expansion of infrastructure
  - decrease in food production.
39. Deflection of winds on earth at different times of the year is caused by
- revolution of the earth
  - ocean currents
  - rotation of the earth
  - sea breezes.

Use the diagram below to answer question 40.

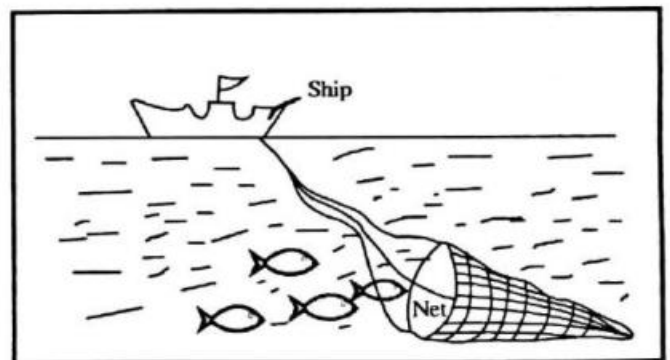

40. The fishing method shown in the diagram above is used
- to catch small numbers of fish
  - near the sea shore
  - in the deep parts of the sea
  - in fast flowing rivers.



41. Below are uses of a certain mineral.
- (i) Flavoring food.
  - (ii) It is used in chemical industries.
  - (iii) Manufacture of paper.
  - (iv) Making of chlorine.
- The mineral described above is
- A. limestone
  - B. diatomite
  - C. fluorspar
  - D. salt.
42. Translation in sign language is important because it
- A. enables deaf people understand messages
  - B. enables people get jobs
  - C. is used by visually impaired people
  - D. enables physically impaired people to move.
43. In the Nyamwezi chiefdoms, the work of Mtwale was to
- A. pass information
  - B. lead the army
  - C. collect taxes
  - D. control trade.
44. Which one of the following pairs of lakes in Africa were formed through volcanic activities?
- A. Lake Malawi and Lake Bangweulu
  - B. Lake Chad and Lake Kyoga
  - C. Lake Volta and Lake Nasser
  - D. Lake Nyos and Lake Kivu.
45. Which of the following causes conflicts in the society?
- A. Democracy
  - B. Negotiation
  - C. Dictatorship
  - D. Tolerance.

46. Which one of the following game parks is **correctly** matched with the country it is found?

Game park	Country
A. Kruger	Mauritius
B. Hwango	Zimbabwe
C. Amboseli	South Africa
D. Serengeti	Kenya

47. Members of the county assembly are elected to represent people living in a
- A. ward
  - B. county
  - C. location
  - D. constituency.
48. Swampy places are **not** good for settlement because they
- A. receive low rainfall
  - B. have infertile soils
  - C. have dense vegetation
  - D. contain disease-causing organisms.
49. The government wants to announce polio vaccination in the country. The **best** form of communication to use is
- A. announce it to pupils in schools
  - B. call for a meeting of all chiefs
  - C. make radio announcement
  - D. advertise in newspaper.
50. Below are descriptions of a traditional leader in Kenya.
- (i) *He led his community to fight the British.*
  - (ii) *He was killed by the British.*
  - (iii) *He performed religious duties.*
- The person described above is
- A. Oloibon Lenana
  - B. Koitalel Arap Samoei
  - C. Nabogo Mumia
  - D. Waiyaki wa Hinga.

51. The family promotes continuity of a community through
- A. payment of dowry
  - B. getting children
  - C. teaching of good behavior
  - D. provision of companionship.

52. Cactus and short bushes are common in
- A. savannah vegetation
  - B. Mediterranean vegetation
  - C. semi desert vegetation
  - D. rainforest vegetation.

53. Which one of the following dams in Africa is **correctly** matched with the rivers where it is built?

Dam	River
A. Kariba	Zambezi
B. Kiambere	Nile
C. Aswan	Volta
D. Akosombo	Tana

54. Struggle for independence in Ghana was led by
- A. Robert Mugabe
  - B. Samora Machel
  - C. Kwame Nkrumah
  - D. Nelson Mandela.

55. The **best** method of curbing drugs and substance abuse in Kenya is by
- A. increasing the price of drugs
  - B. educating people on dangers of drug abuse
  - C. stopping importation of drugs
  - D. starting rehabilitation centers in Kenya.

56. The amount of water vapour in the atmosphere is measured using
- A. a barometer
  - B. a thermometer
  - C. an anemometer
  - D. a hygrometer.

57. The government allows peaceful demonstrations in Kenya in order to
- A. allow citizens to interact
  - B. promote national unity
  - C. give them protection when demonstrating
  - D. respect human rights.

58. The person in charge of elections at a polling station is
- A. presiding officer
  - B. returning officers
  - C. polling clerk
  - D. chairperson of the commission.

59. Which one of the following courts has power to hear and determine election petitions involving presidential candidates? The
- A. court of appeal
  - B. high court
  - C. supreme court
  - D. resident magistrates' court.

60. The **main** function of the county governments in Kenya is to
- A. make laws for the counties
  - B. implement projects in the county
  - C. amend laws in the county
  - D. nominate members of the county assembly.

**PART II: RELIGIOUS EDUCATION**  
**SECTION A**  
**CHRISTIAN RELIGIOUS EDUCATION**

61. The lesson that Christians learn from the actions of Adam and Eve in **Genesis: 3** is that  
A. God is found everywhere  
B. they should repent their sins  
C. God punishes people for their sins  
D. God forgives sins.
62. When Abraham was 75 years old he  
A. left the land of Haran  
B. was circumcised  
C. got his son Isaac  
D. married Sarah.
63. The brothers of Joseph sold him as a slave in Egypt because  
A. slaves were needed in Egypt  
B. they wanted money to buy food  
C. Joseph was a young handsome man  
D. they hated him.
64. When Moses was born his mother hid him because  
A. there was a famine in Egypt  
B. the Israelite baby boys were being killed  
C. the daughter of the king wanted to keep the baby  
D. she saw how handsome the baby was.
65. On the Passover night the Israelite ate  
A. sour grapes  
B. boiled meat  
C. leavened bread  
D. unleavened bread.
66. *"If you give me a son, I promise that I will dedicate him to You....."* (1Samuel 1:11). These words were said at Shiloh by  
A. Hannah  
B. Ruth  
C. Naomi  
D. Abigail.
67. When David was the king of Israel he  
A. played the harp  
B. killed Goliath  
C. built the temple in Jerusalem  
D. brought the covenant box to Jerusalem.
68. The prophet who spoke about the suffering servant was  
A. Jeremiah  
B. Isaiah  
C. Elijah  
D. Joel.
69. Prophet Elisha promised the woman of Shunem a son because she  
A. was a kind person  
B. had no child  
C. was a widow  
D. was a rich woman.
70. *"This very day in David's town, your savior was born, Christ the Lord"* (Luke 2:11) An angel of God said these words to  
A. the wisemen  
B. Zechariah  
C. John the Baptist  
D. the shepherds.
71. When Jesus was forty days old He was taken to the temple for  
A. circumcision  
B. presentation  
C. baptism  
D. the Passover feast.
72. Which two brothers of Jesus left their father in a boat and followed Jesus?  
A. Peter and Andrew  
B. John and James  
C. Andrew and John  
D. Peter and James.
73. *"You are my own dear son. I am pleased with you"* (Luke 3:22) These words were spoken when Jesus was  
A. transfigured  
B. born  
C. baptised  
D. arrested.
74. Which of the following was a teaching of Jesus during the sermon on the mountain?  
A. 'The greatest is the least important'.  
B. 'I am the true vine'.  
C. 'I will not leave you alone'.  
D. 'Do not judge others'.

75. Jesus taught about forgiveness in the parable of  
 A. the talents  
 B. the lost son  
 C. the friend at midnight  
 D. the pearl.
76. Which one of the following events took place during the last supper?  
 A. Jesus and His disciples shared bread.  
 B. Moses and Elijah appeared.  
 C. Jesus sweat blood.  
 D. Jesus rode on a donkey.
77. Pilate released Barabbas during the trial of Jesus because  
 A. Barabbas was an innocent man  
 B. Jesus had refused to perform a miracle  
 C. it was a custom to set a prisoner free  
 D. Jesus had driven traders from the temple.
78. On the day Jesus resurrected, He met two of His disciples on their way to  
 A. Bethany  
 B. Emmaus  
 C. Jericho  
 D. Nazareth.
79. Christians celebrate the resurrection of Jesus during  
 A. Christmas  
 B. advent  
 C. lent  
 D. Easter.
80. The early believers showed their unity in Christ by  
 A. baptizing new converts  
 B. reading the scriptures  
 C. selling their property  
 D. sharing meals.
81. Peter healed the lame beggar near the gate in Jerusalem **mainly** because  
 A. the Holy Spirit was working through him  
 B. he felt pity on the lame beggar  
 C. the lame beggar asked for healing  
 D. it was the hour of prayer.
82. A common belief about God in **both** traditional African Societies and Christian communities is that God is  
 A. everywhere  
 B. served by angels  
 C. the creator  
 D. all knowing.
83. The **main** reason for offering sacrifices in traditional African communities is to  
 A. show peoples wealth  
 B. thank God for His blessings  
 C. remember ancestors  
 D. make new friends.
84. Initiation is done in traditional African societies in order to  
 A. make initiates acquire new roles  
 B. please the parents of the initiates  
 C. make the initiates happy  
 D. remember the ancestors.
85. Priests were important in traditional African communities because they  
 A. led communities to war  
 B. treated diseases among people  
 C. made laws for the society  
 D. led people in offering sacrifices.
86. Sarah, a standard eight pupil, has been given two thousand shillings by her uncle. She can **best** use some of the money to help the community by  
 A. buying herself new clothes  
 B. donating some of the money to the needy  
 C. sharing the money with her friends  
 D. visiting places of interest.
87. John and Tabitha are both in standard eight. The **best** topic to discuss as they walk home is  
 A. talk about their bodily changes  
 B. how to prepare for K.C.P.E.  
 C. to marry after completing school  
 D. the bad behaviour of other pupils.
88. Christians are advised to work in order to  
 A. create wealth in the country  
 B. become rich  
 C. be paid salaries  
 D. avoid being a burden to other people.
89. Pauline, a standard seven pupil has found that she is pregnant. The **best** action for her to take is  
 A. give birth and go back to school  
 B. get married to a man who is responsible  
 C. abort and go back to school  
 D. drop out of school.
90. Christians take part in tree planting day in the world in order to  
 A. be recognized by the country leaders  
 B. get timber to construct houses  
 C. conserve the environment  
 D. create jobs in the country.



# STANDARD EIGHT

## MARKING SCHEME

## K.C.P.E REFLECTOR

ENGLISH	KISWAHILI	MATHS	SCIENCE	SOCIAL STUDIES	
1. B	1. B	1. C	1. B	1. A	51. B
2. C	2. C	2. A	2. B	2. C	52. C
3. A	3. A	3. B	3. A	3. C	53. A
4. D	4. D	4. B	4. A	4. A	54. C
5. C	5. B	5. B	5. B	5. D	55. B
6. B	6. A	6. D	6. D	6. B	56. D
7. A	7. C	7. C	7. B	7. A	57. D
8. B	8. D	8. D	8. C	8. A	58. B
9. C	9. C	9. D	9. B	9. D	59. C
10. D	10. A	10. A	10. D	10. C	60. B
11. A	11. D	11. B	11. B	11. D	<b>C.R.E I.R.E</b>
12. D	12. B	12. C	12. A	12. A	61. C   A
13. C	13. A	13. D	13. B	13. C	62. A   C
14. B	14. C	14. D	14. B	14. B	63. D   D
15. A	15. D	15. A	15. C	15. C	64. B   D
16. D	16. D	16. D	16. B	16. B	65. D   B
17. A	17. C	17. C	17. C	17. D	66. A   A
18. C	18. C	18. B	18. B	18. A	67. D   C
19. B	19. D	19. A	19. A	19. C	68. B   C
20. C	20. B	20. C	20. B	20. B	69. A   B
21. D	21. A	21. D	21. A	21. A	70. D   B
22. A	22. A	22. B	22. C	22. D	71. B   B
23. B	23. B	23. D	23. D	23. A	72. B   A
24. D	24. D	24. B	24. A	24. B	73. C   D
25. C	25. C	25. C	25. C	25. C	74. D   C
26. D	26. A	26. B	26. D	26. D	75. B   A
27. B	27. B	27. B	27. B	27. B	76. A   C
28. A	28. C	28. C	28. C	28. A	77. C   B
29. D	29. C	29. D	29. D	29. C	78. B   A
30. C	30. B	30. C	30. B	30. A	79. D   C
31. D	31. C	31. D	31. A	31. B	80. D   D
32. A	32. A	32. B	32. C	32. A	81. A   B
33. A	33. C	33. B	33. B	33. B	82. C   A
34. C	34. A	34. D	34. B	34. B	83. B   B
35. D	35. A	35. B	35. B	35. C	84. A   D
36. A	36. C	36. C	36. D	36. D	85. C   C
37. D	37. C	37. A	37. A	37. D	86. B   A
38. B	38. D	38. A	38. B	38. A	87. B   B
39. C	39. B	39. A	39. B	39. A	88. D   D
40. A	40. D	40. C	40. C	40. C	89. A   D
41. D	41. B	41. B	41. C	41. D	90. C   B
42. A	42. C	42. D	42. C	42. A	
43. B	43. A	43. B	43. B	43. B	
44. D	44. A	44. A	44. C	44. D	
45. C	45. B	45. B	45. D	45. C	
46. B	46. D	46. B	46. A	46. B	
47. A	47. A	47. D	47. D	47. A	
48. D	48. B	48. C	48. C	48. D	
49. B	49. A	49. B	49. C	49. C	
50. C	50. D	50. C	50. A	50. B	