

3.3 METAL WORK (445)

The 2022 KCSE examinations for Metal work consisted of two papers namely Paper 1 (theory) and Paper 2 (Practical Project). The theory was worth 60% while practical was worth 40% of the final mark. Both papers followed the usual setting format as those of the previous years.

3.3.1 Candidates general performance

The table below shows candidates' overall performance for the five-year period, from 2018 to 2022.

Table 12: Candidates overall performance in the years 2018, 2019, 2020, 2021 and 2022

Year	Paper	Candidature	Maximum Score	Mean Score	Standard Deviation
2018	1	156	60	29.92	11.2
	2		40	20.16	5.17
	Overall		100	49.96	15.65
2019	1	194	60	31.92	11.56
	2		40	21.35	5.37
	Overall		100	53.26	15.72
2020	1	189	60	36.40	11.86
	2		40	24.25	5.13
	Overall		100	60.45	15.96
2021	1	218	60	35.48	12.50
	2		40	23.62	5.86
	Overall		100	58.83	17.58
2022	1	202	60	42.70	8.67
	2		40	28.45	3.92
	Overall		100	71.15	11.77

The following observations can be made from the above table,

- (i) The candidature decreased from 218 in 2021 to 202 in 2022.
- (ii) However, mean score improved from 58.83 in the year 2021 to 71.15 in 2022. This is an indication of a great improvement in performance.
- (iii) The standard deviation dropped from 17.58 in 2021 to 11.77 in 2022.

3.3.2 Metal Work 1 (445/1)

The questions which were reported to have been poorly responded to have been analyzed with a view to pointing out candidates' weaknesses and propose suggestions on some remedial measures that need to be taken in order to improve performance in future. The questions for discussions include 5, 12 and 14.

Question 5

With the aid of sketches, differentiate between a countersunk and a counterbored hole.

Weaknesses

Most of the candidates produced poor sketches which could not differentiate between the two types of holes.

Advice to Teachers

Teacher need to teach holistically including the topic on countersinking and counterboring of holes

Expected response

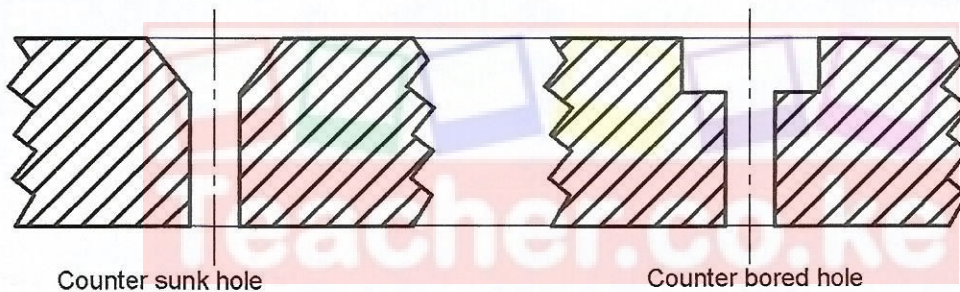

Question 11

Figure 1 shows a shaped block drawn in isometric projection.

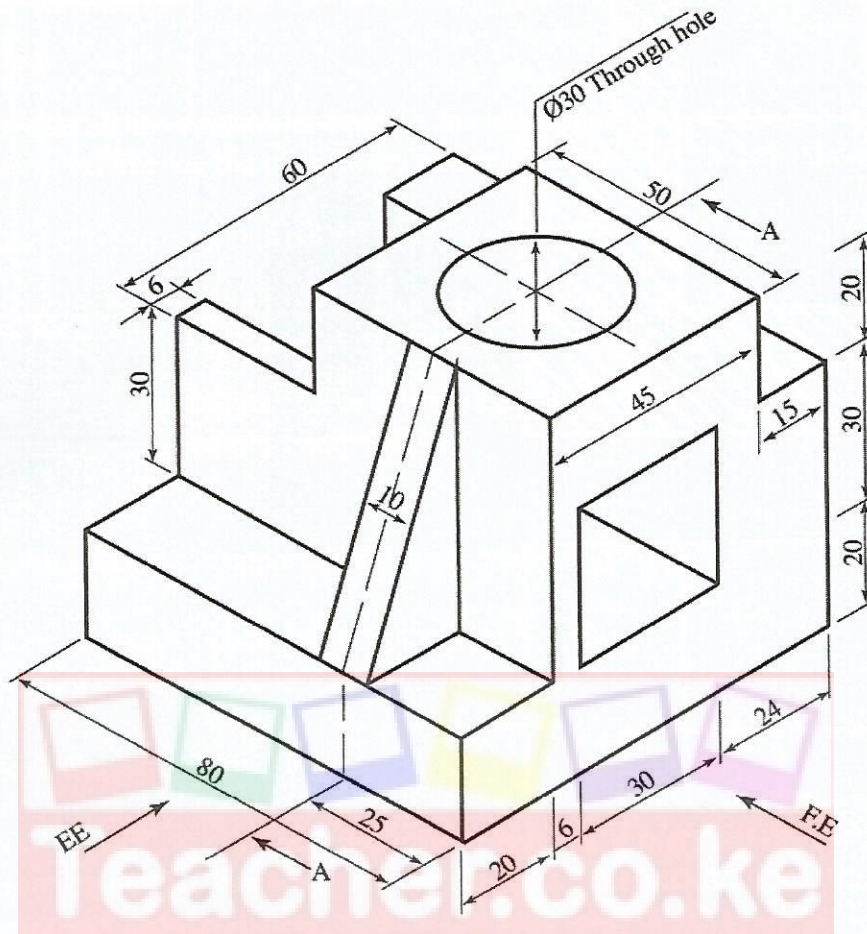

Figure 1

Draw the following views **Full Size** in first angle projection: (15 marks)

- Sectional front elevation along the cutting plane A-A
- End elevation in the direction of arrow E-E
- Plan

Weaknesses

Most candidates could not interpret the drawing and draw the three orthographic views as the question demanded.

Advice to Teachers

Teachers should explain clearly to the students how to interpret drawings given in isometric projection and draw different views in orthographic projection. They should involve the students in drawing objects within their environment for them to understand the concepts of isometric and orthographic projection.

Expected response

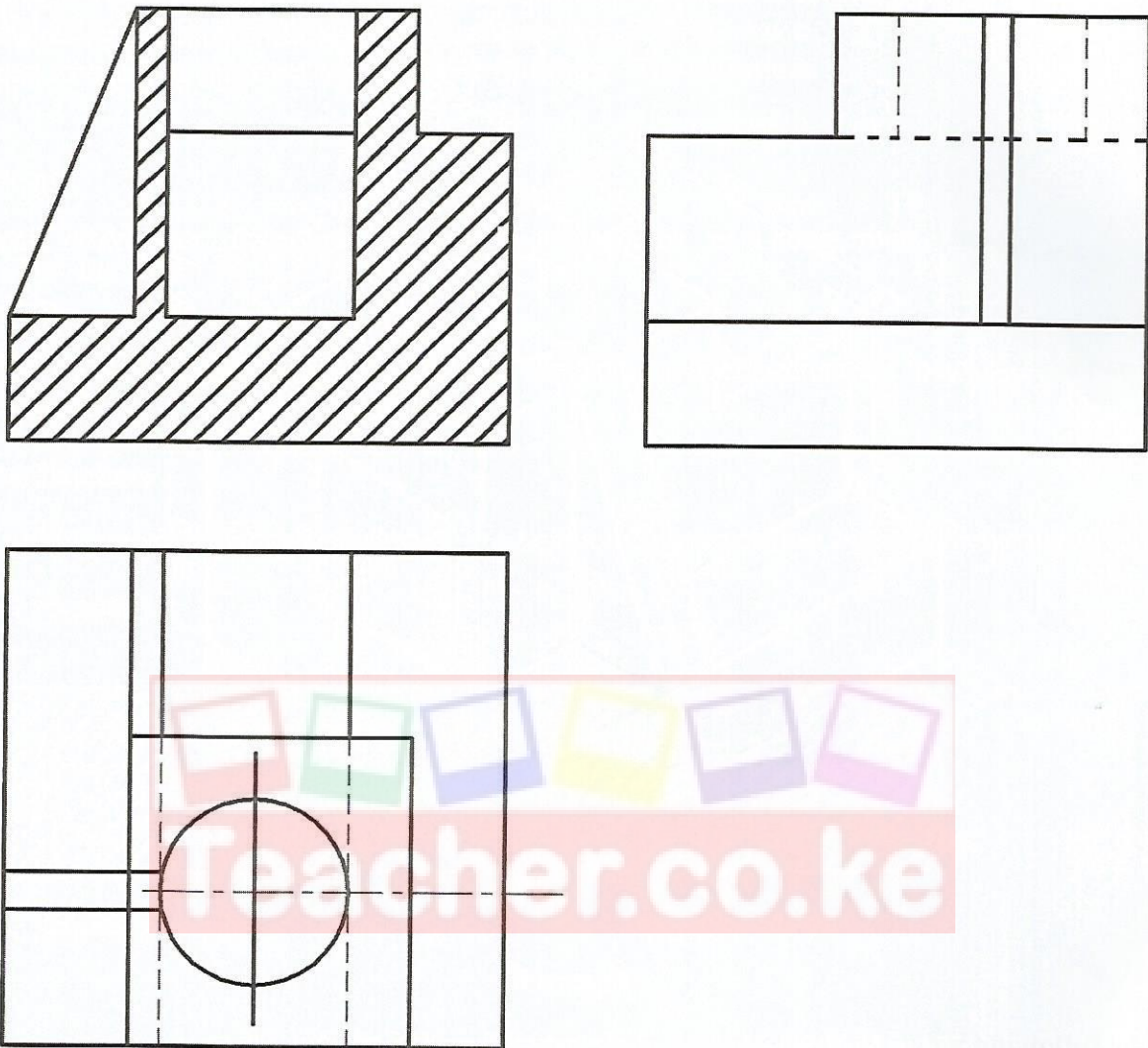

Question 14

Figure 2 shows a mild steel collar bush to be made on a lathe machine.

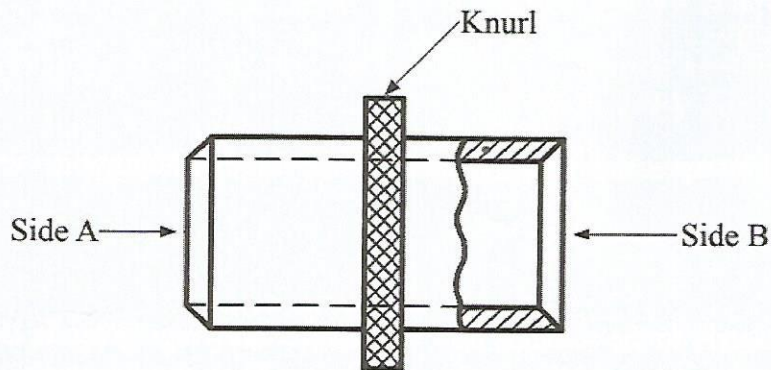

Figure 2

(a) Outline the procedure of making the bush

Weaknesses

Most candidates could not outline the procedure of making the bush on a lathe machine.

Advice to Teachers

Explain to the students all the operations done on the lathe machine and involve them in more practicals for them to internalize the procedures of the operations on the lathe machine.

Expected response

The procedure of making the bush:

- Face both sides A and B
- Parallel turn the diameter of the portion to be knurled
- Parallel turn the smaller diameter on both sides
- Taper turn side A
- Centre drill side A
- Hold side B on the chuck and support side A with the dead centre
- Knurl the ring
- Fix the drill on the tail stock chuck and drill the hole
- Cut the taper on side B with a drill or tool bit

3.3.3 Metal Work Paper 2 (445/2)

Like in the previous years, the council designed a suitable project for this level together with a comprehensive scoring guide. The subject teacher used the working drawings to supervise the fabrication of the project and the scoring guide to mark the candidate's projects. The marks were then uploaded onto the KNEC within the specified time as per the instructions given after revision due to the Covid 2019 pandemic.