



NATIONAL OPEN UNIVERSITY OF NIGERIA

OPERATIONS RESEARCH

ECO 314

SCHOOL OF ARTS AND SOCIAL SCIENCES

COURSE GUIDE

Course Developer
Sufian Jelili Babatunde

National Open University of Nigeria

Course Editor
Dr. Segun Quadri Oyebo Hazzan
Senior Research Fellow
Econometrics Consultant
Limited, Ikoyi Lagos

NATIONAL OPEN UNIVERSITY OF NIGERIA

National Open University of Nigeria

Headquarters

14/16 Ahmadu Bello Way

Victoria Island

Lagos

Abuja Annex

245 Samuel Adesujo Ademulegun Street

Central Business District

Opposite Arewa Suites

Abuja

e-mail: centralinfo@nou.edu.ng

URL: www.nou.edu.ng

National Open University of Nigeria 2014

First Printed

ISBN:

All Rights Reserved

Printed by

For

National Open University of Nigeria *Multimedia Technology in Teaching and Learning*

CONTENT

Introduction- - - - -	4
What you will learn in this course-	4
Course Content- - - - -	4
Course Aims- - - - -	5
Course Objectives- - - - -	5
Working Through This Course-	6
Course Materials- - - - -	6
Study Units - - - - -	6
References and Other Resources-	7
Assignment File- - - - -	7
Presentation Schedule-	7
Assessment- - - - -	7
Tutor-Marked Assignments (TMAs)-	8
Final Examination and Grading-	8
Course Marking Scheme- - - - -	8
Course Overview- - - - -	8
How to Get the Most From This Course-	9
Tutors and Tutorials-	11
Conclusion- - - - -	12

Introduction

ECO314: Operations Research is a three credit course for students offering B.Sc. Economics in the School of Art & Social Science.

The course will consist of eighteen (18) units, that is, five (5) modules. The material has been developed to suit undergraduate students in Economics at the National Open University of Nigeria (NOUN) by using an approach that treats Operations Research. A student who successfully completes the course will surely be in a better position to manage operations of organizations in both private and public organizations.

The course guide tells you briefly what the course is about, what course materials you will be using and how you can work your way through these materials. It suggests some general guidelines for the amount of time you are likely to spend on each unit of the course in order to complete it successfully. It also gives you some guidance on your tutor-marked assignments. Detailed information on tutor-marked assignment is found in the separate assignment file which will be available in due course.

What you will learn in this Course

The course is made up of eighteen units, covering areas such as:

- This course will introduce you to some fundamental aspects of Analysis for Business Decisions, Elements of Decision Analysis, Types of Decision Situations, Decision Trees, Operational Research, Approach to Decision Analysis, System Analysis, Modelling in OR, Simulation, Cases for OR Analysis, Mathematical Programming, Transportation Model, Assignment Model, Game Theory, Project Management, Inventory Control, Sequencing.
- Mathematical Programming (Linear Programming)
- The Transportation Model
- Assignment Model
- Project Management
- Elements of Decision Analysis
- Approaches to Decision Analysis

- Types of Decision Situations
- Decision Trees
- Operations Research (OR)
- Modelling In Operations Research
- Simulation
- Systems Analysis
- Sequencing
- Games Theory
- Inventory Control
- Case for OR Analysis
- Integer Programming
- Indefinite Integra

Course Content

The course aims, among others, are to give you an understanding of the intricacies of Operations Research and how to apply such knowledge in making real life decisions, and managing production and operations units in both private and public enterprises.

The Course will help you to appreciate Rationale behind Analysis for Business Decisions , Elements of Decision Analysis, Types of Decision Situations, Decision Trees, Operational Research, Approach to Decision Analysis, System Analysis, Modelling in OR, Simulation, Cases for OR Analysis, Mathematical Programming, Transportation Model, Assignment Model, Game Theory, Project Management, Inventory Control, Sequencing, Integer Programming and Indefinite Integra

Course Aim

The aims of the course will be achieved by your ability to:

- Identify and explain Elements of Decision Analysis;
- Identify and use various criteria for solving problems in different decision situations;
- discuss the decision tree and solve problems involving the general decision tree and the secretary problem;
- Trace the history and evolution of operation research OR;
- Explain the different approaches to decision analysis;
- discuss the concept of system analysis and identify the various categories of systems;
- Describe model and analyse the different types of models;
- Defined simulation and highlight the various types of simulation models;
- Solve different types of problems involving Linear Programming;

- Explain what transportation problem is all about and solve transportation problems;
- Discuss the elements of assignment problem solve decision problems using various assignment methods;
- Apply various techniques in solving gaming problems.
- Solving inventory problem using the Critical Path Methods (CPM) and the Programme evaluation and Review Techniques (PERT);
- Identify and solve problems using the sequencing techniques.
- Identify and solve Integer programming and Indefinite Integra

COURSE OBJECTIVES

At the end of this course, you should be able to:

- Identify and explain Elements of Decision Analysis;
- Identify and use various criteria for solving problems in different decision situations;
- discuss the decision tree and solve problems involving the general decision tree and the secretary problem;
- Trace the history and evolution of operation research OR;
- Explain the different approaches to decision analysis;
- discuss the concept of system analysis and identify the various categories of systems;
- Describe model and analyse the different types of models;
- Defined simulation and highlight the various types of simulation models;
- Solve different types of problems involving Linear Programming;
- Explain what transportation problem is all about and solve transportation problems;
- Discuss the elements of assignment problem solve decision problems using various assignment methods;
- Apply various techniques in solving gaming problems.
- Solving inventory problem using the Critical Path Methods (CPM) and the Programme evaluation and Review Techniques (PERT);
- Identify and solve problems using the sequencing techniques.

Working through the Course

To successfully complete this course, you are required to read the study units, referenced books and other materials on the course.

Each unit contains self-assessment exercises in addition to Tutor Marked Assessments (TMAs). At some points in the course, you will be required to submit assignments for assessment purposes. At the end of the course there is a final examination. This course

should take about 20 weeks to complete and some components of the course are outlined under the course material subsection.

Course Materials

The major component of the course, what you have to do and how you should allocate your time to each unit in order to complete the course successfully on time are listed follows:

1. Course Guide
2. Study Units
3. Textbooks
4. Assignment File
5. Presentation schedule

Study Units

There are three modules of 18 units in this course, which should be studied carefully. These are:

MODULE 1

- Unit 1: Mathematical Programming (Linear Programming)
- Unit 2: The Transportation Model
- Unit 3: Assignment Model
- Unit 4: Project Management

MODULE 2

- Unit 1: Elements of Decision Analysis
- Unit 2: Approaches to Decision Analysis
- Unit 3: Types of Decision Situations
- Unit 4: Decision Trees

MODULE 3

- Unit 1 : Operations Research (OR)
- Unit 2: Modelling In Operations Research
- Unit 3: Simulation
- Unit 4: Systems Analysis

MODULE 4

- Unit 1: Sequencing
- Unit 2: Games Theory

Unit 3: Inventory Control

References and Other Resources

Every unit contains a list of references and further reading. Try to get as many as possible of those textbooks and materials listed. The textbooks and materials are meant to deepen your knowledge of the course.

Assignment File

There are many assignments in this course and you are expected to do all of them by following the schedule prescribed for them in terms of when to attempt the homework and submit same for grading by your Tutor.

Presentation Schedule

The Presentation Schedule included in your course materials gives you the important dates for the completion of tutor-marked assignments and attending tutorials. Remember, you are required to submit all your assignments by the due date. You should guard against falling behind in your work.

Assessment

Your assessment will be based on tutor-marked assignments (TMAs) and a final examination which you will write at the end of the course.

Tutor-Marked Assignments (TMAs)

Assignment questions for the 18 units in this course are contained in the Assignment File. You will be able to complete your assignments from the information and materials contained in your set books, reading and study units. However, it is desirable that you demonstrate that you have read and researched more widely than the required minimum. You should use other references to have a broad viewpoint of the subject and also to give you a deeper understanding of the subject.

When you have completed each assignment, send it, together with a TMA form, to your tutor. Make sure that each assignment reaches your tutor on or before the deadline given in the Presentation File. If for any reason, you cannot complete your work on time, contact your tutor before the assignment is due to discuss the possibility of an extension. Extensions will not be granted after the due date unless there are exceptional circumstances. The TMAs usually constitute 30% of the total score for the course.

Final Examination and Grading

The final examination will be of two hours' duration and have a value of 70% of the total course grade. The examination will consist of questions which reflect the types of self-assessment practice exercises and tutor-marked problems you have previously encountered. All areas of the course will be assessed

You should use the time between finishing the last unit and sitting for the examination to revise the entire course material. You might find it useful to review your self-assessment exercises, tutor-marked assignments and comments on them before the examination. The final examination covers information from all parts of the course.

Course Marking Scheme

The Table presented below indicates the total marks (100%) allocation.

Assessment	Marks
Assignment (Best three assignment out of the four marked)	30%
Final Examination	70%
Total	100%

Course Overview

The Table presented below indicates the units, number of weeks and assignments to be taken by you to successfully complete the course, Operations Research (ECO 314).

Units	Title of Work	Week's Activities	Assessment (end of unit)
	Course Guide		
MODULE 1			
1	Mathematical Programming (Linear Programming)	Week 1	Assignment 1
2	The Transportation Mode	Week 2	Assignment 1
3	Assignment Model	Week 3	Assignment 1

4	Project Management	Week 4	Assignment 1
MODULE 2			
1	Elements of Decision Analysis	Week 5	Assignment 2
2	Approaches to Decision Analysis	Week 6	Assignment 2
3	Types of Decision Situations	Week 7	Assignment 2
4	Decision Trees	Week 8	Assignment 2
MODULE 3			
1	Operations Research (OR)	Week 9	Assignment 3
2	Modelling In Operations Research	Week 10	Assignment 3
2	Simulation	Week 11	Assignment 3
3	Systems Analysis	Week 12	Assignment 3
MODULE 4			
1	Sequencing	Week 13	Assignment 4
2	Games Theory	Week 14	Assignment 4
3	Inventory Control	Week 15	Assignment 4
	Total	15 Weeks	

How to Get the Most from this Course

In distance learning the study units replace the university lecturer. This is one of the great advantages of distance learning; you can read and work through specially designed study materials at your own pace and at a time and place that suit you best. Think of it as reading the lecture instead of listening to a lecturer. In the same way that a lecturer might set you some reading to do, the study units tell you when to read your books or other material, and when to embark on discussion with your colleagues. Just as a lecturer might give you an in-class exercise, your study units provides exercises for you to do at appropriate points.

Each of the study units follows a common format. The first item is an introduction to the subject matter of the unit and how a particular unit is integrated with the other units and the course as a whole. Next is a set of learning objectives. These objectives let you know what you should be able to do by the time you have completed the unit. You should use these objectives to guide your study. When you have finished the unit you must go back and check whether you have achieved the objectives. If you make a habit of doing this you will significantly improve your chances of passing the course and getting the best grade.

The main body of the unit guides you through the required reading from other sources. This will usually be either from your set books or from a readings section. Self-assessments are interspersed throughout the units, and answers are given at the ends of the units. Working through these tests will help you to achieve the objectives of the unit and prepare you for the assignments and the examination. You should do each self-assessment exercises as you come to it in the study unit. Also, ensure to master some major historical dates and events during the course of studying the material.

The following is a practical strategy for working through the course. If you run into any trouble, consult your Tutor. Remember that your Tutor's job is to help you. When you need help, don't hesitate to call and ask your Tutor to provide the help.

1. Read this Course Guide thoroughly.
2. Organize a study schedule. Refer to the 'Course overview' for more details. Note the time you are expected to spend on each unit and how the assignments relate to the units. Important information, e.g. details of your tutorials, and the date of the first day of the semester is available from study centre. You need to gather together all this information in one place, such as your dairy, a wall calendar, an iPad or a handset. Whatever method you choose to use, you should decide on and write in your own dates for working each unit.
3. Once you have created your own study schedule, do everything you can to stick to it. The major reason that students fail is that they get behind with their course work. If you get into difficulties with your schedule, please let your Tutor know before it is too late for help.
4. Turn to Unit 1 and read the introduction and the objectives for the unit.
5. Assemble the study materials. Information about what you need for a unit is given in the 'Overview' at the beginning of each unit. You will also need both the study unit you are working on and one of your set books on your desk at the same time.
6. Work through the unit. The content of the unit itself has been arranged to provide a sequence for you to follow. As you work through the unit you will be instructed to read sections from your set books or other articles. Use the unit to guide your reading.
7. Up-to-date course information will be continuously delivered to you at the study centre.
8. Work before the relevant due date (about 4 weeks before due dates), get the Assignment File for the next required assignment. Keep in mind that you will learn a lot by doing the assignments carefully. They have been designed to help you meet the objectives of the course and, therefore, will help you pass the exam. Submit all assignments no later than the due date.
9. Review the objectives for each study unit to confirm that you have achieved them. If you feel unsure about any of the objectives, review the study material or consult your Tutor.

10. When you are confident that you have achieved a unit's objectives, you can then start on the next unit. Proceed unit by unit through the course and try to space your study so that you keep yourself on schedule.
11. When you have submitted an assignment to your Tutor for marking, do not wait for its return before starting on the next units. Keep to your schedule. When the assignment is returned, pay particular attention to your Tutor's comments, both on the tutor-marked assignment form and also written on the assignment. Consult your Tutor as soon as possible if you have any questions or problems.
12. After completing the last unit, review the course and prepare yourself for the final examination. Check that you have achieved the unit objectives (listed at the beginning of each unit) and the course objectives (listed in this Course Guide).

Tutors and Tutorials

There are some hours of tutorials (2-hours sessions) provided in support of this course. You will be notified of the dates, times and location of these tutorials, together with the name and phone number of your Tutor, as soon as you are allocated a Tutorial group.

Your tutor will mark and comment on your assignments, keep a close watch on your progress and on any difficulties you might encounter, and provide assistance to you during the course. You must mail your tutor-marked assignments to your tutor well before the due date (at least two working days are required). They will be marked by your Tutor and returned to you as soon as possible.

Do not hesitate to contact your Tutor by telephone, e-mail, or discussion board if you need help. The following might be circumstances in which you would find help necessary. Contact your Tutor if.

- You do not understand any part of the study units or the assigned readings
- You have difficulty with the self-assessment exercises
- You have a question or problem with an assignment, with your Tutor's comments on an assignment or with the grading of an assignment.

You should try your best to attend the tutorials. This is the only chance to have face to face contact with your Tutor and to ask questions which are answered instantly. You can raise any problem encountered in the course of your study. To gain the maximum benefit from course tutorials, prepare a question list before attending them. You will learn a lot from participating in discussions actively.

Conclusion

On successful completion of the course, you would have developed critical thinking and analytical skills (from the material) for efficient and effective discussion of financial system. However, to gain a lot from the course please try to apply everything you learn in the course to term paper writing in other related courses. We wish you success with the course and hope that you will find it both interesting and useful.

TABLE OF CONTENTS

MODULE 1

Unit 1: Mathematical Programming (Linear Programming)

Unit 2: The Transportation Model

Unit 3: Assignment Model

Unit 4: Project Management

MODULE 2

Unit 1: Elements of Decision Analysis

Unit 2: Approaches to Decision Analysis

Unit 3: Types of Decision Situations

Unit 4: Decision Trees

MODULE 3

Unit 1 : Operations Research (OR)

Unit 2: Modelling In Operations Research

Unit 3: Simulation

Unit 4: Systems Analysis

MODULE 4

Unit 1: Sequencing

Unit 2: Games Theory

Unit 3: Inventory Control

MODULE ONE

UNIT 1: MATHEMATICAL PROGRAMMING (LINEAR PROGRAMMING)

- 1.0 Introduction
- 2.0 Objectives
- 3.0 Main Content
 - 3.1 Requirements for Linear Programming Problems
 - 3.2 Assumptions in Linear Programming
 - 3.3 Application of Linear Programming
 - 3.4 Areas of Application of Linear Programming
 - 3.5 Formulation of Linear Programming Problems
 - 3.6 Advantages Linear Programming Methods
 - 3.7 Limitation of Linear programming Models
 - 3.8 Graphical Methods of Linear Programming Solution
- 4.0 Conclusion
- 5.0 Summary
- 6.0 Tutor Marked Assignment
- 7.0 References

1.0 INTRODUCTION

Linear programming deals with the optimization (maximization or minimization) of a function of variables known as objective function, subject to a set of linear equations and/or inequalities known as constraints. The objective function may be profit, cost, production capacity or any other measure of effectiveness, which is to be obtained in the best possible or optimal manner. The constraints may be imposed by different resources such as market demand, production process and equipment, storage capacity, raw material availability, etc. By linearity is meant a mathematical expression in which the

expressions among the variables are linear e.g., the expression $a_1x_1 + a_2x_2 + a_3x_3 + \dots + a_nx_n$ is linear. Higher powers of the variables or their products do not appear in the expressions for the objective function as well as the constraints (they donot have expressions like x_1^3 , $x_2^{3/2}$, x_1x_2 , $a_1x_1 + a_2 \log x_2$, etc.). The variables obey the properties of proportionality (e.g., if a product requires 3 hours of machining time, 5 units of it will require 15 hours) and additivity (e.g., amount of a resource required for a certain number of products is equal to the sum of the resource required for each).

It was in 1947 that George Dantzig and his associates found out a technique for solving military planning problems while they were working on a project for U.S. Air Force. This technique consisted of representing the various activities of an organization as a linear programming (L.P.) model and arriving at the optimal programme by minimizing a linear objective function. Afterwards, Dantzig suggested this approach for solving business and industrial problems. He also developed the most powerful mathematical tool known as “simplex method” to solve linear programming problems.

2.0 OBJECTIVES

At the end of this study unit, you should be able to

- Explain the requirements for Linear Programming
- Highlight the assumptions of Linear Programming
- Identify the Areas of application of Linear Programming
- Formulate a Linear Programming problem
- Solve various problems using Linear Programming

3.0 MAIN CONTENT

3.1 REQUIREMENTS FOR A LINEAR PROGRAMMING PROBLEM

All organizations, big or small, have at their disposal, men, machines, money and materials, the supply of which may be limited. If the supply of these resources were unlimited, the need for management tools like linear programming would not arise at all. Supply of resources being limited, the management must find the best allocation of its resources in order to maximize the profit or minimize the loss or utilize the production capacity to the maximum extent. However this involves a number of problems which can be overcome by quantitative methods, particularly the linear programming.

Generally speaking, linear programming can be used for optimization problems if the following conditions are satisfied:

1. There must be a well-defined objective function (profit, cost or quantities produced) which is to be either maximized or minimized and which can be expressed as a linear function of decision variables.

2. There must be constraints on the amount or extent of attainment of the objective and these constraints must be capable of being expressed as linear equations or inequalities in terms of variables.
3. There must be alternative courses of action. For example, a given product may be processed by two different machines and problem may be as to how much of the product to allocate to which machine.
4. Another necessary requirement is that decision variables should be interrelated and nonnegative. The non-negativity condition shows that linear programming deals with real life situations for which negative quantities are generally illogical.

3.2 ASSUMPTIONS IN LINEAR PROGRAMMING MODELS

A linear programming model is based on the following assumptions:

- 1. Proportionality:** A basic assumption of linear programming is that proportionality exists in the objective function and the constraints. This assumption implies that if a product yields a profit of #10, the profit earned from the sale of 12 such products will be # (10 x 12) = #120. This may not always be true because of quantity discounts. Further, even if the sale price is constant, the manufacturing cost may vary with the number of units produced and so may vary the profit per unit. Likewise, it is assumed that if one product requires processing time of 5 hours, then ten such products will require processing time of 5 x 10 = 50 hours. This may also not be true as the processing time per unit often decreases with increase in number of units produced. The real world situations may not be strictly linear. However, assumed linearity represents their close approximations and provides very useful answers.
- 2. Additivity:** It means that if we use t_1 hours on machine A to make product 1 and t_2 hours to make product 2, the total time required to make products 1 and 2 on machine A is $t_1 + t_2$ hours. This, however, is true only if the change-over time from product 1 to product 2 is negligible. Some processes may not behave in this way. For example, when several liquids of different chemical compositions are mixed, the resulting volume may not be equal to the sum of the volumes of the individual liquids.
- 3. Continuity:** Another assumption underlying the linear programming model is that the decision variables are continuous i.e., they are permitted to take any non-negative values that satisfy the constraints. However, there are problems wherein variables are restricted to have integral values only. Though such problems, strictly speaking, are not linear programming problems, they are frequently solved by linear programming techniques and the values are then rounded off to nearest integers to satisfy the constraints. This approximation, however, is valid only if the variables have large optimal values. Further, it must be ascertained whether the solution represented by the rounded values is a feasible solution and also whether the solution is the best integer solution.

4. Certainty: Another assumption underlying a linear programming model is that the various parameters, namely, the objective function coefficients, R.H.S. coefficients of the constraints and resource values in the constraints are certainly and precisely known and that their values do not change with time. Thus the profit or cost per unit of the product, labour and materials required per unit, availability of labour and materials, market demand of the product produced, etc. are assumed to be known with- certainty. The linear programming problem is, therefore, assumed to be deterministic in nature.

5. Finite Choices: A linear programming model also assumes that a finite (limited) number of choices (alternatives) are available to the decision-maker and that the decision variables are interrelated and non-negative. The non-negativity condition shows that linear programming deals with real-life situations as it is not possible to produce/use negative quantities.

Mathematically these non-negativity conditions do not differ from other constraints. However, since while solving the problems they are handled differently from the other constraints, they are termed as non-negativity restrictions and the term constraints is used to represent constraints other than non-negativity restrictions and this terminology has been followed throughout the book.

3.3 APPLICATIONS OF LINEAR PROGRAMMING METHOD

Though, in the world we live, most of the events are non-linear, yet there are many instances of linear events that occur in day-to-day life. Therefore, an understanding of linear programming and its application in solving problems is utmost essential for today's managers.

Linear programming techniques are widely used to solve a number of business, industrial, military, economic, marketing, distribution and advertising problems. Three primary reasons for its wide use are:

1. A large number of problems from different fields can be represented or at least approximated to linear programming problems.
2. Powerful and efficient techniques for solving L.P. problems are available.
3. L.P. models can handle data variation (sensitivity analysis) easily.

However, solution procedures are generally iterative and even medium size problems require manipulation of large amount of data. But with the development of digital computers, this disadvantage has been completely overcome as these computers can handle even large L.P. problems in comparatively very little time at a low cost.

3.4 AREAS OF APPLICATION OF LINEAR PROGRAMMING

Linear programming is one of the most widely applied techniques of operations research in business, industry and numerous other fields. A few areas of its application are given below.

1. INDUSTRIAL APPLICATIONS

(a) Product mix problems: An industrial concern has available a certain production capacity (men, machines, money, materials, market, etc.) on various manufacturing processes to manufacture various products. Typically, different products will have different selling prices, will require different amounts of production capacity at the several processes and will, therefore, have different unit profits; there may also be stipulations (conditions) on maximum and/or minimum product levels. The problem is to determine the product mix that will maximize the total profit.

(b) Blending problems: These problems are likely to arise when a product can be made from a variety of available raw materials of various compositions and prices. The manufacturing process involves blending (mixing) some of these materials in varying quantities to make a product of the desired specifications.

(c) Production scheduling problems: They involve the determination of optimum production schedule to meet fluctuating demand. The objective is to meet demand, keep inventory and employment at reasonable minimum levels, while minimizing the total cost Production and inventory.

(d) Trim loss problems: They are applicable to paper, sheet metal and glass manufacturing industries where items of standard sizes have to be cut to smaller sizes as per customer requirements with the objective of minimizing the waste produced.

(e) Assembly-line balancing: It relates to a category of problems wherein the final product has a number of different components assembled together. These components are to be assembled in a specific sequence or set of sequences. Each assembly operator is to be assigned the task / combination of tasks so that his task time is less than or equal to the cycle time.

2. MANAGEMENT APPLICATIONS

(a) Media selection problems: They involve the selection of advertising mix among different advertising media such as T.V., radio, magazines and newspapers that will maximize public exposure to company's product. The constraints may be on the total advertising budget, maximum expenditure in each media, maximum number of insertions in each media and the like.

(b) Portfolio selection problems: They are frequently encountered by banks, financial companies, insurance companies, investment services, etc. A given amount is to be allocated among several investment alternatives such as bonds, saving certificates,

common stock, mutual fund, real estate, etc. to maximize the expected return or minimize the expected risk.

(c) Profit planning problems: They involve planning profits on fiscal year basis to maximize profit margin from investment in plant facilities, machinery, inventory and cash on hand.

(d) Transportation problems: They involve transportation of products from, say, n sources situated at different locations to, say, m different destinations. Supply position at the sources, demand at destinations, freight charges and storage costs, etc. are known and the problem is to design the optimum transportation plan that minimizes the total transportation cost (or distance or time).

(e) Assignment problems: They are concerned with allocation of facilities (men or machines) to jobs. Time required by each facility to perform each job is given and the problem is to find the optimum allocation (one job to one facility) so that the total time to perform the jobs is minimized.

3.5 FORMULATION OF LINEAR PROGRAMMING PROBLEMS

First, the given problem must be presented in linear programming form. This requires defining the variables of the problem, establishing inter-relationships between them and formulating the objective function and constraints. A model, which approximates as closely as possible to the given problem, is then to be developed. If some constraints happen to be nonlinear, they are approximated to appropriate linear functions to fit the linear programming format. In case it is not possible, other techniques may be used to formulate and then solve the model.

EXAMPLE 1 (Production Allocation Problem)

A firm produces three products. These products are processed on three different machines. The time required to manufacture one unit of each of the three products and the daily capacity of the three machines are given in the table below.

TABLE 1

Machine	Time per unit (minutes)			Machine capacity (minutes/day)
	Product 1	Product 2	Product 3	
M_1	2	3	2	440
M_2	4	-	3	470

M_3	2	5	-	430
-------	---	---	---	-----

It is required to determine the daily number of units to be manufactured for each product. The profit per unit for product 1, 2 and 3 is #4, #3 and #6 respectively. It is assumed that all the amounts produced are consumed in the market. Formulate the mathematical (L.P) model that will maximize the daily profit.

Formulation of Linear Programming Model

Step 1:

From the study of the situation find the key-decision to be made. In this connection, looking for variables helps considerably. In the given situation key decision is to decide the extent of products 1, 2 and 3, as the extents are permitted to vary.

Step 2:

Assume symbols for variable quantities noticed in step 1. Let the extents. (amounts) of products, 1, 2 and 3 manufactured daily be x_1 , x_2 and x_3 units respectively.

Step 3:

Express the feasible alternatives mathematically in terms of variables. Feasible alternatives are those which are physically, economically and financially possible. In the given situation feasible alternatives are sets of values of x_1 , x_2 and x_3 ,

where $x_1, x_2, x_3 \geq 0$,

since negative production has no meaning and is not feasible.

Step 4:

Mention the objective quantitatively and express it as a linear function of variables. In the present situation, objective is to maximize the profit.

i.e., maximize $Z = 4x_1 + 3x_2 + 6x_3$.

Step 5:

Put into words the influencing factors or constraints. These occur generally because of constraints on availability (resources) or requirements (demands). Express these constraints also as linear equations/inequalities in terms of variables.

Here, constraints are on the machine capacities and can be mathematically expressed as

$$2x_1 + 3x_2 + 2x_3 \leq 440,$$

$$4x_1 + 0x_2 + 3x_3 \leq 470,$$

$$2x_1 + 5x_2 + 0x_3 \leq 430.$$

EXAMPLE 2 (Blending Problem)

A firm produces an alloy having the following specifications:

- (i) specific gravity ≤ 0.98 ,
- (ii) chromium $\geq 8\%$,
- (iii) melting point $\geq 450^\circ\text{C}$.

Raw materials A, B and C having the properties shown in the table can be used to make the alloy.

Table 3

Property	Properties of raw material		
	A	B	C
Specific gravity	0.92	0.97	1.04
Chromium	7%	13%	16%
Melting point	440 ^o C	490 ^o C	480 ^o C

Costs of the various raw materials per ton are: #90 for A, #280 for B and #40 for C. Formulate the L.P model to find the proportions in which A, B and C be used to obtain an alloy of desired properties while the cost of raw materials is minimum.

Formulation of Linear Programming Model

Let the percentage contents of raw materials A, B and C to be used for making the alloy be x_1 , x_2 and x_3 respectively.

Objective is to minimize the cost

i.e., minimize $Z = 90x_1 + 280x_2 + 40x_3$.

Constraints are imposed by the specifications required for the alloy.

They are

$$0.92x_1 + 0.97x_2 + 1.04x_3 \leq 0.98,$$

$$7x_1 + 13x_2 + 16x_3 \geq 8,$$

$$440x_1 + 490x_2 + 480x_3 \geq 450,$$

$$\text{and } x_1 + x_2 + x_3 = 100,$$

as x_1 , x_2 and x_3 are the percentage contents of materials A, B and C in making the alloy.

Also x_1 , x_2 , x_3 , each ≥ 0 .

Formulation of Linear Programming Model

Let x_1 , x_2 , x_3 and x_4 denote the number of advertising units to be bought on television, radio, magazine I and magazine II respectively.

The objective is to maximize the total number of potential customers reached.

i.e., maximize $Z = 10(2x_1 + 6x_2 + 1.5x_3 + x_4)$.

Constraints are on the advertising budget: $30,000x_1 + 20,000x_2 + 15,000x_3 + 10,000x_4 \leq 450,000$

$$\text{or } 30x_1 + 20x_2 + 15x_3 + 10x_4 \leq 450,$$

on number of female customers reached by the advertising campaign:
 $150,000x_1 + 400,000x_2 + 70,000x_3 + 50,000x_4 \geq 100,000$

$$\text{or } 15x_1 + 40x_2 + 7x_3 + 5x_4 \geq 100$$

on expenses on magazine advertising: $15,000x_3 + 10,000x_4 \leq 150,000$ or $15x_3 + 10x_4 \leq 150$

on no. of units on magazines: $x_3 \geq 3$,

$$x_4 \geq 2,$$

on no. of units on television: $5 \leq x_1 \leq 10$ or $x_1 \geq 5$, $x_1 \leq 10$

on no. of units on radio: $5 \leq x_2 \leq 10$ or $x_2 \geq 5$, $x_2 \leq 10$

where x_1 , x_2 , x_3 , x_4 , each ≥ 0 .

EXAMPLE 3 (Inspection Problem)

A company has two grades of inspectors, I and II to undertake quality control inspection. At least 1,500 pieces must be inspected in an 8-hour day. Grade I inspector can check 20 pieces in an hour with an accuracy of 96%. Grade II inspector checks 14 pieces an hour with an accuracy of 92%.

Wages of grade I inspector are #5 per hour while those of grade II inspector are #4 per hour. Any error made by inspector costs #3 to the company. If there are, in all, 10 grade I inspectors and 15 grade II inspectors in the company find the optimal assignment of inspectors that minimizes the daily inspection cost.

Formulation of L.P Model

Let x_1 and x_2 denote the number of grade I and grade II inspectors that may be assigned the job of quality control inspection.

The objective is to minimize the daily cost of inspection. Now the company has to incur two types of costs: wages paid to the inspectors and the cost of their inspection errors. The cost of grade I inspector/hour is;

$$\# (5 + 3 \times 0.04 \times 20) = \#7.40.$$

Similarly, cost of grade II inspector/hour is

$$\# (4 + 3 \times 0.08 \times 14) = \#7.36.$$

: The objective function is

$$\text{minimize } Z = 8(7.40x_1 + 7.36x_2) = 59.20x_1 + 58.88x_2.$$

Constraints are on the number of grade I inspectors: $x_1 \leq 10$,

on the number of grade II inspectors : $x_2 \leq 15$,

on the number of pieces to be inspected daily:

$$20 \times 8x_1 + 14 \times 8x_2 \geq 1,500$$

$$\text{or } 160x_1 + 112x_2 \geq 1,500,$$

where $x_1, x_2 \geq 0$.

EXAMPLE 4 (Product Mix Problem)

Consider the following problem faced by a production planner in a soft drink plant. He has two bottling machines A and B. A is designed for 8-ounce bottles and B for 16-ounce

bottles. However; each can be used on both types of Bottles with some lass of efficiency. The following data are available:

Machine	8-ounce bottles	16-ounce bottles
A	100/minute	40/minute
B	60/minute	75/minute

The machines can be run 8-hour per day, 5 days a week. Profit on 8-ounce bottle is 15 paise and on 16-ounce bottle is 25 paise. Weekly production of the drink cannot exceed 300,000 ounces and the market can absorb 25,000 eight-ounce bottles and 7,000 sixteen-ounce bottles per week. The planner wishes to maximize his profit subject, of course, to all the production and marketing constraints. Formulate this as L.P problem.

Formulation of Linear Programming Model

Key decision is to determine the number of 8-ounce bottles and 16-ounce bottles to be produced on either of machines A and B per week. Let x_{A1} , x_{B1} be the number of 8-ounce bottles and x_{A2} , x_{B2} be the number of 16-ounce bottles to be produced per week on machines A and B respectively.

Objective is to maximize .the weekly profit.

$$\text{i.e., maximize } Z = \#[0.15 (x_{A1} + x_{B1}) + 0.25(x_{A2} + x_{B2})].$$

Constraints can be formulated as follows:

Since an 8-ounce bottle takes 1/100minute and a 16-ounce bottle takes 1/40 minute on

machine A and the machine can be run for 8 hours a day and 5 days a week, the time constraint on machine A can be written as

$$\frac{x_{A1}}{100} + \frac{x_{A2}}{40} \leq 5 \times 8 \times 60$$

$$\leq 2,400$$

Similarly, time constraint on machine B can be written as

$$\frac{x_{B1}}{60} + \frac{x_{B2}}{75} \leq 2,400.$$

Since the total weekly production cannot exceed 300,000 ounces,

$$8(x_{A1} + x_{B1}) + 16(x_{A2} + x_{B2}) \leq 300,000.$$

The constraints on market demand yield

$$x_{A1} + x_{B1} \geq 25,000,$$

$$x_{A2} + x_{B2} \geq 7,000,$$

where x_{A1} , x_{B1} , x_{A2} , x_{B2} , each ≥ 0 .

3.6 ADVANTAGES OF LINEAR PROGRAMMING METHODS

Following are the main advantages of linear programming methods:

1. It helps in attaining the optimum use of productive factors. Linear programming indicates how a manager can utilize his productive factors most effectively by a better selection and distribution of these elements. For example, more efficient use of manpower and machines can be obtained by the use of linear programming.
2. It improves the quality of decisions. The individual who makes use of linear programming methods becomes more objective than subjective. The individual having a clear picture of the relationships within the basic equations, inequalities or constraints can have a better idea about the problem and its solution.
3. It also helps in providing better tools for adjustments to meet changing conditions. It can go a long way in improving the knowledge and skill of future executives.
4. Most business problems involve constraints like raw materials availability, market demand, etc. which must be taken into consideration. Just because we can produce so many units of products does not mean that they can be sold. Linear programming can handle such situations also since it allows modification of its mathematical solutions.

3.7 LIMITATIONS OF LINEAR PROGRAMMING MODEL

This model, though having a wide field, has the following limitations:

1. For large problems having many limitations and constraints, the computational difficulties are enormous, even when assistance of large digital computers is available. The approximations required to reduce such problems to meaningful sizes may yield the final results far different from the exact ones.
2. Another limitation of linear programming is that it may yield fractional valued answers for the decision variables, whereas it may happen that only integer values of the variables are logical.

For instance, in finding how many lathes and milling machines to be produced, only integer values of the decision variables, say x_1 and x_2 are meaningful. Except when the variables have large values, rounding the solution values to the nearest integers will not

yield an optimal solution. Such situations justify the use of special techniques like integer programming.

3. It is applicable to only static situations since it does not take into account the effect of time. The O.R. team must define the objective function and constraints which can change due to internal as well as external factors.

3.8 GRAPHICAL METHOD OF SOLUTION

Once a problem is formulated as mathematical model, the next step is to solve the problem to get the optimal solution. A linear programming problem with only two variables presents a simple case, for which the solution can be derived using a graphical or geometrical method. Though, in actual practice such small problems are rarely encountered, the graphical method provides a pictorial representation of the solution process and a great deal of insight into the basic concepts used in solving large L.P. problems. This method consists of the following steps:

1. Represent the given problem in mathematical form i.e., formulate the mathematical model for the given problem.
2. Draw the x_1 and x_2 -axes. The non-negativity restrictions $x_1 \geq 0$ and $x_2 \geq 0$ imply that the values of the variables x_1 and x_2 can lie only in the first quadrant. This eliminates a number of infeasible alternatives that lie in 2nd, 3rd and 4th quadrants.
3. Plot each of the constraint on the graph. The constraints, whether equations or inequalities are plotted as equations. For each constraint, assign any arbitrary value to one variable and get the value of the other variable. Similarly, assign another arbitrary value to the other variable and find the value of the first variable. Plot these two points and connect them by a straight line. Thus each constraint is plotted as line in the first quadrant.
4. Identify the feasible region (or solution space) that satisfies all the constraints simultaneously. For type constraint, the area on or above the constraint line i.e., away from the origin and for type constraint, the area on or below the constraint line i.e., towards origin will be considered. The area common to all the constraints is called feasible region and is shown shaded. Any point on or within the shaded region represents a feasible solution to the given problem. Though a number of infeasible points are eliminated, the feasible region still contains a large number of feasible points

4.0 CONCLUSION

Linear programming involves with the optimization (maximization or minimization) of a function of variables known as objective function, subject to a set of linear equations and/or inequalities known as constraints. The objective function may be profit, cost, production capacity or any other measure of effectiveness, which is to be obtained in the

best possible or optimal manner. The constraints may be imposed by different resources such as market demand, production process and equipment, storage capacity, raw material availability and so on.

5.0 SUMMARY

We have learnt in this unit that all organizations, big or small, have at their disposal, men, machines, money and materials, the supply of which may be limited. If the supply of these resources were unlimited, the need for management tools like linear programming would not arise at all. Supply of resources being limited, the management must find the best allocation of its resources in order to maximize the profit or minimize the loss or utilize the production capacity to the maximum extent. However this involves a number of problems which can be overcome by quantitative methods, particularly the linear programming. Generally speaking, linear programming can be used for optimization problems if the following conditions are satisfied- there must be a well-defined objective function; there must be constraints on the amount or extent of attainment of the objective and these constraints must be capable of being expressed as linear equations or inequalities in terms of variables; there must be alternative courses of action; decision variables should be interrelated and nonnegative; and the resources must be in limited supply. Linear Programming has the following assumptions- Proportionality, Additivity, Continuity, Certainty, and Finite Choices. LP solution methods can be applied in solving industrial problems, management related problems, and a host of other problem areas.

6.0 TUTOR MARKED ASSIGNMENT

1. Briefly discuss what linear programming involves.
2. Identify and discuss five assumptions of linear programming.
3. List and explain three areas where linear programming can be applied.

7.0 REFERENCES

Dixon – Ogbechi, B.N (2001). Decision Theory in Business, Lagos: Philglad Nig. Ltd.

Denardo, Eric V. (2002). The Science of Decision making: A Problem-Based Approach Using Excel. New York: John Wiley.

Gupta, P.K., and Hira, D.S. (2012). Operations Research, New – Delhi: S. Chand & Company.

Lucey, T. (1988). Quantitative Techniques: An Instructional Manual, London: DP Publications.

UNIT 2: THE TRANSPORTATION MODEL

- 1.0 Introduction
- 2.0 Objectives
- 3.0 Main Content
 - 3.1 Assumptions Made in the Use of the Transportation Model
 - 3.2 Theoretical Consideration
 - 3.3 General Procedure for Setting Up a Transportation Model
 - 3.4 Developing an Initial Solution
 - 3.4.1 The North West Corner Method
 - 3.4.2 The Least Cost Method
 - 3.4.3 Vogel's Approximation Method (VAM)
 - 3.5 The Unbalanced Case
 - 3.6 Formulating Linear Programming Model for the Transportation Problem
 - 3.7 Improving the Initial Feasible Solution Through Optimization
 - 3.8 Determination of the Optimal Transportation Cost Using the Stepping Stone Method
 - 3.9 The Modified Distribution Method
 - 3.10 Degeneracy
- 4.0 Conclusion
- 5.0 Summary
- 6.0 Tutor Marked Assignment
- 7.0 References

1.0 INTRODUCTION

We now go on to another mathematical programming problem which is a special case of linear programming model. Unlike the linear programming method, treated in the last unit of this book, which focuses on techniques of minimizing cost of production or maximizing profit, this special linear programming model deals with techniques of evolving the lowest cost plan for transporting product or services from multiple origins which serve as suppliers to multiple destinations that demand for the goods or services.

As an example, suppose cows are to be transported in a day from 5 towns in the northern part of Nigeria to 4 towns in the south. Each of the five northern towns has the maximum they can supply in a day, while each of the town in the southern part also has the specified quantities they demand for. If the unit transportation cost from a source to each of the destinations is known it is possible to compute the quantity of cows to be transported from each of the northern towns to the southern towns in order to minimize the total transportation cost.

2.0 OBJECTIVES

After completing this chapter, you should be able to:

- Describe the nature of a transportation problem.
- Compute the initial feasible solution using the North West Corner method.
- Find the initial feasible solution using the Least Cost Method.
- Compute the initial feasible solution using the Vogel's Approximation Method.
- Use the Stepping Stones and Modified Distribution Methods to find the optimum solution.

3.0 MAIN CONTENT

3.1 ASSUMPTIONS MADE IN THE USE OF THE TRANSPORTATION MODEL

The transportation model deals with a special class of linear programming problem in which the objective is to transport a homogeneous commodity from various origins or factories to different destinations or markets at a total minimum cost (Murthy, 2007)

In using transportation model the following major assumptions are made.

1. The Homogeneity of materials to be transported. The materials or items to be transported by road, sea, air or land must be the same regardless of their specific source or specified locations.

2. Equality of transportation cost per unit. The transportation cost per unit is the same irrespective of which of the materials is to be transported.

3. Uniqueness of route or mode of transportation between each source and destination.

In using the transportation model it is essential that the following information are made available.

- The list of each source and its respective capacity for supplying the materials
- The list of each destination and its respective demand for that period.
- The unit cost of each item from each source to each destination.

3.2 THEORETICAL CONSIDERATION

Suppose we have a transportation problem involving movement of items from m sources (or origins) to n location (destination) at minimum cost. Let c_{ij} be the unit cost of transporting an item from source i to location j ; a_i be the quantity of items available at source i and b_j the quantity of item demanded at location j . Also, let x_{ij} be the quantity transported from i^{th} source to j^{th} location then total supply = $\sum a_{ij}$, while total demand = $\sum b_{ij}$. This problem can be put in tabular form as shown below:

	1	2	3 n	Supply
1	c_{11}	c_{12}	c_{13} n	a_1
2	c_{21}	c_{22}	c_{23} n	a_2
3	c_{31}	c_{32}	c_{33} n	a_3
:	:	:	:	:	:
m	c_{m1}			c_{mn}	a_m
Demand	b_1	b_2	b_3 b_m	

when $\sum_{i=1}^m a_{ij} = \sum_{j=1}^n b_{ij}$ then we have the balanced case. The linear

Programming model can be formulated as follows: $\sum_{i=1}^m \sum_{j=1}^n C_{ij}$

Subject to the constraints-

$$\sum_{i=1}^n a_1 = \dots \dots i = 1, 2, \dots$$

$$\sum_{i=1}^m = b_1 = \dots \dots i = 1 \dots n$$

$$X_{ij} \geq 0$$

3.3 GENERAL PROCEDURE FOR SETTING UP A TRANSPORTATION MODEL

Convert statement of the problem into tabular form showing the total supply and total demand for each of the sources and destinations.

- Check that total number of supply equals the total number of demand to know whether the transportation model is of the balanced or unbalanced type.
- Allocate values into the necessary cells using the appropriation techniques for the method of allocation of quantities that you have selected. We expect the number of allocated cells to be $m+n-1$ where m is the number of rows and n is the number of columns otherwise degenerating occurs.
- . Compute the total cost of transportation.

Solution of transportation problem comes up in two phases namely:

- The initial feasible solution
- The optimum solution to the transportation problem

3.4 DEVELOPING AN INITIAL SOLUTION

When developing an initial basic feasible solution there are different methods that can be used. We shall discuss three methods used namely;

1. The North West Corner Method
2. The Least Cost Method
3. Vogel's Approximation Method

It is assumed that the least cost method is an improvement on the North West Corner method, while the Vogel's approximation method is an improvement of the least cost method.

3.4.1 THE NORTH WEST CORNER METHOD

This is the simplest and most straight forward format of the method of developing an initial basic feasible solution. The initial solution resulting from this method usually Operations Research in Decision Analysis and Production Management results in the largest total transportation cost among the three methods to be discussed. To explain how to use this method, we present an illustrative data of a transportation problem in the example below:

Table 1 Supply and demand of cows

Sources	Lagos	Akure	Awka	Supply
Sokoto	90	85	70	600
Kano	175	110	95	1400
Maiduguri	205	190	130	1000
Demand	1600	1050	350	

Example 1

Suppose the table above gives us the supply of cows from three sources in the north and the demands by three locations in the southern part of Nigeria. The quantities inside the cell represent the unit costs, in naira, of transporting one cow from one source to one location. Use the North West Corner method to allocate the cows in such a way as to minimise the cost of transportation and find the minimum cost.

Solution

We observe that the total demand = $1600 + 1050 + 350 = 3000$ and total supply = $600 + 1400 + 1000 = 3000$. Since demand supply we have a balanced transportation problem

To use the North West Corner method to allocate all the cows supplied to the cells where they are demanded, we follow this procedure:

- Starting from the North West Corner of the table allocate as many cows as possible to cell (1,1). In this case it is 600. This exhausts the supply from Sokoto leaving a demand of 1000 cows for Lagos.

Sources	Lagos	Akure	Awka	Supply
Sokoto	90 600	85 -	70 -	600
Kano	175	110	95	1400
Maiduguri	205	190	130	350 100
Demand	1600 1000	1050	350	

- Allocate 1000 cows to cell (2,1) to meet Lagos demand leaving a supply of 400 cows in Kano. Cross out the 1000 in column 1 where the demand has been met

Sources	Lagos	Akure	Awka	Supply
Sokoto	90 600	85 -	70 -	600
Kano	175 1000	110 -	95	1400 400

Maiduguri	205	190	130	100
Demand	1600 1000	1050	350	

1. Allocate 400 cows to cell (2, 2) to exhaust the supply from Kano leaving a demand of 650 in Akure. Cross out the 1400 in row 2 which has been satisfied.

Sources	Lagos	Akure	Awka	Supply
Sokoto	90 600	85 -	70 -	600
Kano	175 1000	110 400	95 -	400 1400
Maiduguri	205 -	190 650	130 350	1000
Demand	1600 1000	1050 650	350	

1.0 Allocate 650 cows to cell (3,2) to satisfy the demand in Akure

Sources	Lagos	Akure	Awka	Supply
Sokoto	90 600	85 -	70 -	600
Kano	175 1000	110 400	95 -	400 1400
Maiduguri	205 -	190 650	130 350	350 1000
Demand	1600 1000	1050 650	350	

1. Allocate 350 cows to cell (3, 3) to satisfy the demand in Awka and exhaust the supply in Maiduguri. Cross out the 350.

Location

Sources	Lagos	Akure	Awka	Supply
Sokoto	90 600	85 -	70 -	600
Kano	175 1000	110 400	95 -	400 1400
Maiduguri	205	190	130	350

	-	650	350	1000
Demand	1600 1000	1050 650	350	

This completes the allocation. We observe that out of the 9 cells only 5 cells have been allocated. If m is the number of rows, n is the number of columns the total number of allocated cells in this case is $m + n - 1$ i.e $3 + 3 - 1 = 5$.

The transportation cost is found by multiplying unit cost for each cells by its unit allocation and summing it up.

i.e. $C = \sum (\text{unit cost} \times \text{cell allocation})$

$= (600 \times 90) + (1000 \times 175) + (400 \times 110) + (650 \times 190) + (130 \times 350)$

$= 54000 + 175000 + 44000 + 123500 + 45500$

$= \text{N}442000$

This can be summarised in tabular form as follows

Cell	Quantity	Unit Cost	Cost
(1, 1)	600	90	54000
(2, 1)	1000	175	175000
(2, 2)	400	110	44000
(3, 2)	650	190	123500
(3, 3)	130	350	45500
			442000

3.4.2 THE LEAST COST METHOD

This method is also known as the minimum cost method. Allocation commences with the cell that has the least unit cost and other subsequent method of allocation is similar to the North West Corner method

Example 2

Solve example 2 using the Least Cost method

Solution

We observe that the total demand = $1600 + 1050 + 350 = 3000$ and total supply = $600 + 1400 + 1000 = 3000$. Since demand = supply we have a balanced transportation problem.

We note that the least cost per unit in this problem is N70 in cell (1, 3). We do the allocation as follows:

Step 1: Allocate 350 to cell (1, 3) to satisfy the demand at Awka and leaving a supply of 250 cows at Sokoto. Cross out column 3 that has been satisfied.

Table 2

Location

Sources	Lagos	Akure	Awka	Supply
Sokoto	90	85	70	250
	-	250	350	600
Kano	175	110	95	1400
			-	
Maiduguri	205	190	130	
		-	-	1100
Demand	1600	1050	350	

Step 2:

Allocate 250 cows to cell (1, 2) that has the next smallest unit cost of N85 to complete the supply from Sokoto leaving us with demands of 800 cows at Akure. Cross out exhausted row one.

Sources	Lagos	Akure	Awka	Supply
Sokoto	90	85	70	250
	-	250	350	600
Kano	175	110	95	600
			-	1400
Maiduguri	205	190	130	1100
Demand	1600	1050 800	350	

Step 3: Allocate 800 cows to cell (2, 2) with the next least cost leaving 110 to satisfy demand at Akure, leaving us with supply of 600 ram at Kano cross out satisfied column 2.

Location

Sources	Lagos	Akure	Awka	Supply
Sokoto	90 -	85 250	70 350	250 600
Kano	175 600	110 800	95 -	600 1400
Maiduguri	205 1000	190 -	130 -	1100
Demand	1600	1050 800	350	

Step 4: Allocate 600 cows to cell (2, 1) which has the next least cost of 175 thereby exhausting supply from Kano, leaving 1000 cows demand in Lagos. Cross out exhausted row 2.

Location

Sources	Lagos	Akure	Awka	Supply
Sokoto	90 -	85 250	70 350	250 600
Kano	175 600	110 800	95 -	600 1400
Maiduguri	205	190 -	130 -	1100
Demand	1600 1000	1050 800	350	

Step 5: Allocate the remaining 1000 cows to cell (3, 1) to exhaust the supply from Maiduguri. This completes the allocation.

Location

Sources	Lagos	Akure	Awka	Supply
Sokoto	90	85	70	250

	-	250	350	600
Kano	175 600	110 800	95 -	600 1400
Maiduguri	205 1000	190	130 -	1100
Demand	1600 1000	1050 800	350	

The minimum cost of transportation is given by:

$$(85 \times 250) + (70 \times 350) + (175 \times 360) + (110 \times 800) + (205 \times 1,000) = 21,250 + 24,500 + 105,000 + 88,000 + 205,000 = 443,750$$

We can represent it in a tabular form as follow

Cells	Quantity	Unit Cost	Cost
(1, 2)	250	80	21250
(1, 3)	350	70	24500
(2, 1)	600	175	105000
(2, 2)	800	110	88000
(3, 1)	1000	205	205000
			443750

Example 3

In the table below, items supplied from origins A, B, C and D and those demanded in locations 1, 2, 3 and 4 are shown. If the figures in the boxes are the unit cost of moving an item from an origin to a destination, use the least cost method to allocate the material in order to minimize cost of transportation.

Destination

Origin	1	2	3	4	Supply
A	29	41	25	46	1250
B	50	27	45	33	2000
C	43	54	49	40	500
D	60	38	48	31	2750
Demand	3250	250	1750	1250	

Solution:

We check the total demand and supply. In this case both totals are equal to 6500. It is balanced transportation problem. We set up the allocation as follows;

Step 1

Look for the least cost. It is 25 in cell (1, 3) Allocate 1250 to cell (1, 3) and thus exhaust the supply by A while leaving a demand of 500 in column three. Cross out the 1250 in A and the other cells on row 1.

Step 2

Look for the least cost among the remaining empty cells. This is 27 in cell (2,2) Allocate all the demand of 250 to that cell. Cross out the 250 in column 2 and the 2000 supply in row 2 becomes 1750. Cross out the empty cells in column 2.

Step 3

Once again identify the cell with the least cost out of the remaining empty cells. This is 31 in cell (4, 4). Allocate all the 1250 in column 4 to this cell to satisfy the demand by column 4. This leaves a supply of 1500 for row D. Cross out all the other cells in column 4. Step 4.

Identify the cell having the least cost among the remaining cell. This is 43 in cell (3, 1). Allocate all the 500 supply to this cell and cross out the 500 in satisfied row 3 as well as any empty cell in that row. Also cross out the 3250 row and replace with 3250 — 500 = 2750.

Step 5

Identify the cell with the least cost among the empty cell. This is 45 in cell (2,3). Since column 3 needs to exhaust 500 we allocate this to cell (2, 3). Cross out the 500 and any empty cell in that column. Row 2 needs to exhaust 1250 quantity.

Step 6

Examine the remaining empty cells for the cell with the least cost. This is cell (2, 1) with N50. Allocate all the 1250 into this cell. Cross out 2750 in column 1 and write the balance of 1500.

Step 7

The last cell remaining is (4, 1). Allocate the remaining 1500 to this cell thus satisfying the remaining demands of row 4 and the remaining supply of column 1.

Destination

Origin	1	2	3	4	Supply
A	29 -	41 -	25 1250	46 -	1250
B	50 1250	27 250	45 500	33	750 1250 2000
C	43	54	49	40	500

	500	-	-	-	
D	60	38	48	31	2750 1500
	1500	-	-	1250	
Demand	3250 2750	250	1750 500	1250	

We then calculate the cost as follows

Cells	Quantity	Unit Cost	Cost
(2, 1)	1250	50	62500
(3, 1)	500	43	21500
(4, 1)	1500	60	90000
(2, 2)	250	27	6750
(1, 3)	1250	25	31250
(2, 3)	500	45	22500
(4, 4)	1250	31	38750
			273,250

Note that total number of cell allocations $m + n - 1$ where $m = 4$ and $n =$ number of columns = 4

3.4.3 VOGEL'S APPROXIMATION METHOD (VAM)

This technique of finding an initial solution of the transportation is an improvement on both the least cost and North West corner methods. It involves minimization of the penalty or opportunity cost. This penalty cost is the cost due to failure to select the best alternatives. This technique can thus be regarded as the penalty or regret method.

The steps for using the VAM method can be presented as follows.

- Check the row and column totals to ensure they are equal.
- Compute the row and column penalties for the unit costs. This is done by finding the difference between the smallest cell cost and the next smallest cell cost for each row and column.
- Identify the row or column with the highest penalty cost.
- Allocate to the cell with the least cost in the identified cell in step 3 the highest possible allocation it can take.
- Cross out all the redundant cell.
- Re compute the penalty cost and proceed to allocate as done in the previous steps until all the cells have been allocated.

- Check for the $m + n - 1$ requirement.
- Compute the total cost.

Example 4

Solve example 4 using the Vogel's Approximation Method

Solution

(i) The first step is to check the row and column totals and since both totals equal 6500, it is a balanced transportation problem.

(ii) Next we compute the row and column penalty costs denoted by $d_1!$ and d_1 respectively and obtain the following table:

	1	2	3	4	Supply	$d_1!$
A	29	41	25	46	1250	4
B	50	27	45	33	2000	6
C	43	54	49	40	500	3
D	60	38	48	31	2750	7
Demand	3250	2500	1750	1250	6500	
d_1	14	11	20	2		

(iii) The highest penalty cost is 20; we allocate to the least unit cost in that column the highest it can take. The least is 25 and is allocated 1250 as shown below.

(iv) The next step is to re-compute the penalty costs, $d_2!$ and d_2 for the unbalanced cells in both rows and column. The results obtained are as follows.

	1	2	3	4	Supply	$d_1!$	$d_2!$
A	29	41	25 1250	46 -	1250	4	-
B	50	27 250	45	33	2000 1750	6	6
C	43	54 -	49	40	500	3	3
D	60	38 -	48	31	2750	7	7
Demand	3250	250	1750 500	1250	6500		
d_1	14	11	20	2			
d_2	7	11	3	2			

Since all cells in the row 1 have all been allocated $d_2 = 0$ for that row.

(v) The highest penalty cost is 11. We allocate the maximum allocation for cell (2,1) which has the least cost of 27 which is 250. Row 2 has a balance of 1750 to be exhausted while column 2 is satisfied.

(vi) Next we compute penalty costs $d_3!$ and d_3 for the unallocated cells and obtain the following.

	1	2	3	4	Supply	$d_1!$	$d_2!$	$d_3!$
A	29	41	25 1250	46 -	1250	4	-	-
B	50	27 250	45	33	2000 1750	6	6	12
C	43	54 -	49	40	500	3	3	3
D	60	38 -	48	31 1250	2750 1500	7	7	17
Demand	3250	250	1750 500	1250	6500			
d_1	14	11	20	2				
d_2	7	11	3	2				
d_3	7	-	3	2				

The highest penalty cost is 17 and the unit cost is 31. We give the cell with unit cost of 31 its maximum allocation of 1250 thereby exhausting the demand in column 3 and leaving a balance of 1500 in row 4.

(vii) We re-compute the penalty cost $d_4!$ and d_4 and then fill up all the other cells

	1	2	3	4	Supply	$d_1!$	$d_2!$	$d_3!$	$d_4!$
A	29	41	25 1250	46 -	1250	4	-	-	
B	50	27 250	45	33	2000 1750	6	6	12	5
C	43	54 -	49	40	500	3	3	3	6
D	60	38 -	48 500	31 1250	2750 1500	7	7	17	12
Demand	3250	250	1750 500	1250	2750				
d_1	14	11	20	2					
d_2	7	11	3	2					
d_3	7	-	3	2					

d ₄	7	-	3	-					
----------------	---	---	---	---	--	--	--	--	--

The highest penalty costs is 12, we allocate cell (4, 3) having the least unit cost of 48 maximally with 500 to exhaust row 3. All the remaining cells in column 3 are given 0 allocations since column 3 has now been exhausted.

(viii) We then allocate the remaining empty cells as follows: cell (2, 1) is given the balance of 1750 to exhaust the supply of row 2. Cell (3, 1) is given supply of 500 to exhaust the supply of row 3 while cell (4, 1) is allocated to the balance of 1000.

(ix) A total of 7 cells have been allocated satisfying $m + n - 1$ criterion. We then compute the minimum cost of allocation in the transportation model and obtain the following;

Cells	Quantity	Unit Cost	Cost
(1, 3)	25	1250	62500
(2, 1)	50	1750	21500
(2, 2)	27	250	90000
(3, 1)	43	500	6750
(4, 1)	60	1000	31250
(4, 3)	48	500	22500
(4, 4)	31	1250	38750
Total			269750

We observed that this value is an improvement on the value of N273, 250 obtained by the Least Cost Method.

3.5 THE UNBALANCED CASE

Suppose the total number of items supplied is not equal to the total number of items demanded. When this happens then we have an unbalanced transportation problem. To solve this type of problem we adjust the transportation table by creating a dummy cell for source or demand column or row to balance the number. The dummy cells created are allocated zero transportation unit cost and the problem is solved using appropriate method as before. We have two cases, namely (1) the case when supply is greater than demand ($SS > DD$) (2) the case when the demand is greater than the supply ($DD > SS$). The next two examples will show us how the dummy is created and how the problem is solved.

Example 5

The table below shows us how some items are transported from five locations A,B,C,D to four location P,Q,R,S with the unit cost of transportation in them being shown in the box. Determine the initial feasible solution by finding minimum cost of transportation using the North West Corner method.

	P	Q	R	S	Supply
A	150	120	135	105	2000
B	90	140	130	140	8000
C	120	100	120	150	7000
D	180	140	200	162	3000
E	110	130	100	160	2500
Demand	1000	4000	8500	4500	

The total from the supply is $2000 + 8000 + 7000 + 3000 + 2500 = 22500$.

The total quantity demanded is $1000 + 4000 + 8500 + 4500 = 18,000$. Since the supply is more than the demand. We then create out a new dummy variable, with column T to take care of the demand with value of $22500 - 18000 = 4500$. We now have a table with five rows and time columns.

	P	Q	R	S	T	Supply
A	150	120	135	105	0	2000
B	90	140	130	140	0	8000
C	120	100	120	150	0	7000
D	180	140	200	162	0	3000
E	110	130	100	160	0	2500
Demand	1000	4000	8500	4500	4500	

We then carry out the allocation using the usual method to get the table below. So the table becomes.

	P	Q	R	S	T	Supply
A	150 1000	120 1000	135	105	0	4000 2000
B	90	140 3000	130 5000	140	0	5000 8000
C	120	100	120 3500	150 3500	0	3500 7000
D	180	140	200	162 1000	0 2000	2000 3000
E	110	130	100	160	0 2500	2500
Demand	1000	4000 3000	8500 3500	4500 1000	4500 2000	

The allocations are shown above. The cost can be computed as follows

Cells	Quantity	Unit Cost	Cost
-------	----------	-----------	------

(1, 1)	1000	180	180000
(1, 2)	1000	120	120000
(2, 2)	3000	140	420000
(2, 3)	5000	130	650000
(3, 3)	3500	120	420000
(3, 4)	3500	150	525000
(4, 4)	1000	162	162000
(4, 5)	2000	0	0
(5, 5)	2500	0	0
Total			2477000

Example 6

Find the minimum cost of this transportation problem using the North West Corner method.

	1	2	3	Supply
A	10	8	12	150
B	16	14	17	200
C	19	20	13	300
D	0	0	0	250
Demand	300	200	400	900

Solution

Total for demand = $300 + 200 + 400 = 900$ Total for supply is $150 + 200 + 300 = 650$

Here Demand is greater than Supply. According to Lee (1983) one way of resolving this is to create a dummy variable to make up for the $900 - 650 = 250$ difference in the supply and to assign a value of 0 to this imaginary dummy variable. We then end up with 4 x 3 table as shown below:

The cells are now allocated using the principles of North West Corner method

	1	2	3	Supply
A	10 150	8 -	12 -	150
B	16 150	14 50	17 -	200 150
C	19 -	20 - 150	13 - 150	300
D	0 -	0 -	0 250	250
Demand	300	200	400	900

	150	150	150	
--	-----	-----	-----	--

The cost can be computed as follows

Cells	Quantity	Unit Cost	Cost
(1, 1)	150	10	1500
(2, 1)	150	16	2400
(2, 2)	50	14	700
(3, 2)	150	20	3000
(3, 3)	150	13	1950
(4, 3)	250	0	0
Total			9550

3.6 FORMULATING LINEAR PROGRAMMING MODEL FOR THE TRANSPORTATION PROBLEM

The linear programming model can also be used for solving the transportation problem. The method involves formulating a linear programming model for the problem using the unit costs and the quantities of items to be transported. In case the decision variables are the quantities to be transported, we may represent the decision variable for cell 1 column 1 as x_{11} , cell 2 column 2 as x_{22} e.t.c. Constraints are created for both rows (supply) and column (demand). There is no need of constraints for the total. For the balanced case we use equality for the supply and demand constants. For the unbalanced case we use equality for the lesser quantity between supply and demand while the greater of the two will use the symbol “less than or equal to (\leq)“. Dummy variables will be created to balance the requirements for demand and supply.

Example 7

Formulate a linear programming model for the transportation problem

	Ofada	Ewokoro	Abeokuta	Supply
Ikeja	5	8	2	250
Yaba	4	3	7	100
Agege	9	6	5	450
Lagos	3	4	6	300
Demand	600	200	300	

Solution

Total demand $600 + 200 + 300 = 1100$ while

Total supply $250 + 100 + 450 + 300 = 1100$. This is a balanced transportation problem.

We therefore use equality signs for the supply and demand constraints.

Let X_{11} , X_{12} , X_{13} be the quantities for row 1. The other quantities for the remaining rows are similarly defined.

The objective function consists of all the cell costs as follows

$$\text{Minimize } 5X_{11} + 8X_{12} + 2X_{13} + 4X_{21} + 3X_{22} + 7X_{23} + 9X_{31} + 6X_{32} + 5X_{33} + 3X_{41} + 4X_{42} + 6X_{43}$$

The constraints are

$$\text{Supply (Row) } X_{11} + X_{12} + X_{13} = 250$$

$$X_{21} + X_{22} + X_{23} = 100$$

$$X_{31} + X_{32} + X_{33} = 450$$

$$X_{41} + X_{42} + X_{43} = 300$$

$$\text{Demands (column) } X_{11} + X_{11} + X_{11} = 600$$

$$X_{21} + X_{22} + X_{23} = 200$$

$$X_{31} + X_{32} + X_{33} = 300$$

3.7 IMPROVING THE INITIAL FEASIBLE SOLUTION THROUGH OPTIMISATION

After the feasible solutions have been found using the North West Corner Method, the Least Cost Method and the Vogel's Approximation Method (VAM) we move on to the next and final stage of finding the minimum transportation cost using optimisation technique on the obtain feasible solution. Various methods have been proffered for finding this optimum solution among which are the following:

- 1) The Stepping Stone Method
- 2) The Modified Distribution Method (MOD1) which is an improvement on the stepping stone method and is more widely accepted.

3.8 DETERMINATION OF THE OPTIMAL TRANSPORTATION COST USING THE STEPPING STONE METHOD

The optimal solution is found due to need to improve the result obtained by the North West Corner Method, the Least Cost Method and the Vogel's Approximation Method.

The stepping stone method is used to improve the empty or unallocated cells by carefully stepping on the other allocated cells. The method was pioneered by Charnes. A and Cooper W. W, and is based on the idea of the Japanese garden which has at the center

stepping stones carefully laid across the path which enables one to cross the path by stepping carefully on the stones.

The criterion of $m + n - 1$ number of occupied cells must be satisfied to avoid degeneracy. The stepping stone method is similar to the simplex method in the sense that occupied cells are the basic variables of the simplex method while the empty cells are the non-basic variables. To find the optimum solution we assess a stepping stone path by stepping on allocated cells in order to evaluate an empty cell. The set of allocated cells that must be stepped on in order to evaluate an unallocated cell is known as the stepping stone path. It is identical to the positive or negative variables on a non-basic column of the simplex tableau. The critical thing to do is to find the stepping stone path in order to find out the net change in transportation by re-allocation of cells. In re-allocating cells it is very important that the total supply and total demand is kept constant.

The following steps are essential in using the stepping stone method:

- Identify the stepping stone path for all the unallocated cells.
- Trace the stepping stone paths to identify if transportation of one unit will incur a difference in total transportation cost. One may need to skip an empty cell or even an occupied cell when tracing the path. We usually represent increase with a positive sign and a decrease with negative sign.
- Using the traced stepping stone paths analyze the unit transportation cost in each cell. Compute the Cost Improvement Index (CII) for each empty cell.
- Select the cell with the largest negative CII for allocation, bearing in mind the need to ensure that the demand and supply are both kept constant and calculate the cost of transportation. Re-compute the CII for the new table. if all the CII's are positive then we have reached the optimum allocation otherwise the procedure is iterated until we get positive values for all the CII's in the transportation table.

The following points should be noted when using the stepping stone method:

- It will be observed that if iteration is necessary the transportation cost in each of the subsequent table will reduce until we obtain the optimum solution.
- Only sources transport goods to destinations. Re-allocation is done using horizontal movements for rows and vertical movement columns.
- Every empty cell has a unique stepping stone path.
- The stepping stone path consists of allocated cells.

Example 8

You are given the following transportation table. Find (a) the initial basic feasible solution using the Least Cost Method (b) the optimum solution using the Stepping Stone.

Method

	Abuja	Bauchi	Calabar	Supply
Ibadan	6	7	9	70000
Jos	5	8	7	10000
Kano	7	9	6	150000
Demand	130000	90000	110000	

Solution

This is a case of unbalanced transportation problem since the total demand is 330,000 while the total supply is 230,000. We therefore create a dummy row of 100,000 to balance up. The result obtained by the Least Cost Method is shown in the table below;

	Abuja	Bauchi	Calabar	Supply
Ibadan	6 70000	7	9	70000
Jos	5 10000	8	7	10000
Kano	7 50000	9	6 100000	150000
Dummy	0	0 90000	0 10000	100000
Demand	130000	90000	110000	330000

Minimum cost is given as follows

Cell	Quantity	Unit cost	Cost
(1,1)	70000	6	420000

(2,1)	10000	5	50000
(3,1)	50000	7	350000
(3,3)	100000	6	600000
(4,2)	90000	0	0
(4,3)	10000	0	0
			1420000

(b) We now find the optimum solution using the result obtained by the Least Cost Method. We first identify the empty cells in the table of initial feasible solution. The cells are **Cell (1,2), Cell (1, 3), Cell (2,2), Cell (2,3) and Cell (4,1)**

Next we evaluate empty cells to obtain the stepping stone path as well as the Cost Improvement indices (CII) as follows:

Cell (1,2): The Stepping Stone Path for this cell is

$$+ (1,2) - (4,2) + (4,3) - (1,1) + (3,1) - (3,3)$$

	Abuja	Bauchi	Calabar	Supply
Ibadan	(-) 6	(+) 7 70000	9	70000
Jos	5 10000	8	7	10000
Kano	(+) 7	9	(-) 6	

	120000	30000	150000	
Dummy	0	(-) 0 20000	(+) 0 80000	100000
Demand	130000	90000	110000	330000

The CII for cell (1,2) is $+7 - 0 + 0 - 6 + 7 = +2$

Cell (1,3) The Stepping Stone Path for this cell is $+(1,3) - (1,1) + (3,1) - (3,3)$. The allocation matrix for this cell is shown below:

	Abuja	Bauchi	Calabar	Supply
Ibadan	(-) 6 70000	7 70000	(+)9 70000	70000
Jos	5 10000	8	7	10000
Kano	(+) 7 120000	9	(-)6 30000	150000

Dummy	0	0 90000	0 10000	100000
Demand	130000	90000	110000	330000

CII is given as $+9 - 6 + 7 - 6 = +4$

Cell (2,2) the stepping stone path for the cell is

$+(2,2) - (4,2) + (4,3) - (3,3) + (3,1) - (2,1)$ the obtained matrix is as follows:

	Abuja	Bauchi	Calabar	Supply
Ibadan	6 70000	7	9	70000
Jos	(-5)5	(+)8	7	10000
Kano	(+) 7 60000	9	(-)6 90000	150000

	120000	30000	150000	
Dummy	0	(-) 0 8000	(+) 0 20000	100000
Demand	130000	90000	110000	330000

The cell CII for cell (2, 2) is given as $+8 - 0 + 0 - 6 + 7 - 5 = +4$

Cell (2, 3) the stepping stone path is $+(2, 3) - (3, 3) + (3,1) - (2,1)$

The allocation matrix for the cell is as follows

	Abuja	Bauchi	Calabar	Supply
Ibadan	6 70000	7	9	70000
Jos	(-)5	8	(+)7 10000	10000
Kano	(+) 7 60000	9	(-) 6 90000	150000
Dummy	0	(-)0 20000	0 10000	100000
Demand	130000	90000	110000	330000

The CII for cell (2, 3) is given by $+7 - 6 + 7 - 5 = +3$

Cell (3, 2) the stepping stone Path is

$+(3,2) - (4,2) + (4,3) - (3,3)$.

The matrix of the allocation is shown below;

	Abuja	Bauchi	Calabar	Supply
Ibadan	6 70000	7	9	70000
Jos	5 10000	8	7	10000
Kano	(+) 7 50000	(+)9 10000	(-) 6 90000	150000
Dummy	0	(-)0 80000	0 20000	100000
Demand	130000	90000	110000	330000

The CII for cell (3, 2) is given by $+9-0 + 0 - 6 = +3$

Cell (4, 1) the stepping stone Path is

$+(4,1) - (3,1) + (3,3) - (4,3)$.

The allocation matrix is given below

	Abuja	Bauchi	Calabar	Supply
--	-------	--------	---------	--------

Ibadan	6 70000	7	9	70000
Jos	5 10000	8	7	10000
Kano	(-) 7 40000	(+)9	(-) 6 110000	150000
Dummy	(+)0 10000	0 90000	(-)0 100000	
Demand	130000	90000	110000	330000

The CII for cell (4,1) is given as $+0-7+6-0=-1$

Since cell (4,1) has negative CII the optimum solution has not been reached. We need to compute the CII for the un allocated cells in the table for cell (4,1) shown above.

The empty cells are **Cell (1,2); Cell (1,3); Cell (2,2); Cell (2,3); Cell (3,2) and Cell (4,3)**

For Cell (1,2) The Stepping Stone Path is $+(1,2) - (4,1) + (4,2) - (1,1)$.

The CII $=+7 - 0 + 0 - 6 =+1$

For Cell(1,3)The Stepping Stone Path is $+(1,3)-(1,1)+(3,1) - (3,3)$

The CII $=+9 - 6 + 7 - 6 =+4$

For Cell (2,2) The Stepping Stone Path is $+(2,2) - (4,2) + (4,1) - (2,1)$

The CII $=+8 - 0 + 0 - 7= +3$

For Cell (2,3) The Stepping Stone Path is $+(2,3) - (3,3) + (3,1) - (2,1)$

The CII $= +7 - 6 +7 - 5 = +3$

For Cell (3,2) The Stepping Stone Path is $+(3,2) - (4,2) + (4,1) - (3,1)$

TheCil

For Cell (4,3) The Stepping Stone Path is $+(4,3) - (3,3) + (3,1) - (4,1)$

The CII $=+0 - 6 +7 - 0=1$

Since the CIIs are all positive an optimal solution has been found in the last table

	Abuja	Bauchi	Calabar	Supply
Ibadan	6 70000	7	9	70000

Jos	5 10000	8	7	10000
Kano	7 40000	9	6 110000	150000
Dummy	0 10000	0 90000	0	100000
Demand	10000	90000	110000	330000

Ibadan to Abuja 70,000 @ N6 = 70,000 x 6= 420,000

From Jos to Abuja 1,000 @ N5 = 10,000 x 5 = 50,000

From Kano to Abuja 40,000 @ N7 = 40,000 x 7 = 280,000

From Kano to Calabar 110,000 @ N6 = 110,000 x 6= 660,000 Dummy to Abuja
10,000 @ NO = 10,000 x 0=0

Dummy to Bauchi 90,000 @ NO = 90,000 x 0=0

1,410,000

We observe that the minimum cost of 1, 420, 000 obtained by the Least Cost Method has been reduced by the stepping stone method to give s the optimum transportation cost of 1,410, 000.

3.9 THE MODIFIED DISTRIBUTION METHOD

This method is usually applied to the initial feasible solution obtained by the North West Corner method and the Least Cost method since the initial feasible solution obtained by the Vogel's Approximation Method, is deemed to be more accurate than these two. To use this method we take the following steps:

Step 1: Using the obtained feasible solution, compute the row dispatch unit cost r_i and the column reception unit cost c_j at location j for every cell with allocation using

$$C_{ij} = r_i + c_j$$

Conventionally, $r_i = 0$

Note that r_i is the shadow cost of dispatching a unit item from source to cell k_{ij} while c_j is the shadow cost of receiving a unit of the item from location j to cell k_{ij} and c_{ij} is the cost of transporting a unit of the item from source i to location j in the corresponding cell k_{ij} .

If we have a 3 x 3 cell we obtain $r_1, r_2, r_3, c_1, c_2,$ and c_3 respectively.

Step 2

Compute the unit shadow costs for each of the empty unallocated cells using the various obtained c_i and r_i

Step 3

Obtain the differences in unit costs for the unallocated cells using

$$C_{ij}^1 = c_{ij} - (r_i + c_j)$$

If these differences are all positive for the empty cells the minimum optimum solution has been obtained. If we have one or more records of any negative difference then it implies that an improved solution can still be obtained and so we proceed to step 4.

Step 4

We select the cell with the highest negative value of C_{ij} . If more than one of them have the same negative C_{ij} (i.e. the unit shadow cost is greater than the actual cost), that is a tie occurs we select any one of them arbitrarily for transfer of units.

Step 5

Transfer to the empty cells the minimum value possible from an allocated cell, taking care that the values of the demand and supply are unaffected by the transfer and that no other empty cell is given allocation.

Step 6

Develop a new solution and test if it is the optimum solution

Step 7

If it is not, repeat the procedures by starting from step 1 until the optimum solution is obtained.

Example 9

In the transportation table given below:

(a) Find the initial feasible solution using (i) the least cost method (ii) the Vogel's approximation method.

Use the modified Distribution method to find the optimum solution using the initial feasible solution obtained by the Least Cost Method.

	1	2	3	Supply
X	9	11	15	400
Y	15	7	17	500
Z	11	5	7	600
Demand	500	450	550	

Solution

We use the least cost method to obtain this table

	1	2	3	Supply
X	9	11	15	
	400	-	-	400
Y	15	7	17	
	100	-	400	500
Z	11	5	7	
	-	450	150	600
Demand	500	450	550	

The Least Cost value is $(400 \times 9) + (100 \times 15) + (450 \times 5) + (400 \times 17) + (550 \times 7)$
 $= 3600 + 1500 + 2250 + 6800 + 1050 = 15200$

Minimum cost by least cost = 15200

ii. Using the Vogel approximation method,

	X	Y	Z	Supply	d ₁	d ₂	d ₃
A	9 400	11 -	15 -	400	2	6	6*
B	15 50	7 450	17 -	500	8*	2	2
C	11 50	5 -	7 550	600	2	4	-
Demand	150	100	130				
d ₁₁	2	2	8				
d ₂₁	2	-	8*				
d ₃₁	6	-	2				

The cost by the Vogel Approximation method is $(400 \times 9) + (50 \times 15) + (50 \times 11) + (550 \times 7)$

$= 3600 + 750 + 550 + 3150 + 3850 = 11900$

(b) Using the Modified Distribution Method on the Least Cost Risk

(c) We now use the Modified Distribution method on the initial solution obtained by the Least Cost Method We follow the steps allowed as shown below

Step 1

Reproduce the obtained feasible solution by least cost method

	1	2	3	Supply
X	9	11	15	
	400	-	-	400
Y	15	7	17	
	100	-	400	500
Z	11	5	7	
	-	450	150	600
Demand	500	450	550	

Minimum cost by least cost = 15200

We then compute the unit shown costs for each of the allocated cells as follows

By convention $r_1 = 0$

In cell (1,1) $r_1 + c_1 = 9 \dots c_1 = 9$

In cell (2,1) $r_2 + c_1 = 15 \quad \therefore r_2 = 15 - 9 = 6$

In cell (2,3) $r_2 + c_3 = 17 \quad \therefore c_3 = 17 - 6 = 11$

In cell (3,3) $r_3 + c_3 = 7 \quad \therefore r_3 = 7 - 11 = -4$

In cell (3,2) $r_3 + c_2 = 5 \quad \therefore c_2 = 5 - (-4) = 9$

We summarise as follows

$$r_1 = 0 \qquad c_1 = 9$$

$$r_2 = 6 \qquad c_2 = 9$$

$$r_3 = -4 \qquad c_3 = 11$$

Steps 2 and 3

We compute the difference in unit cost for the unoccupied cells as follows

$$\text{For cell (1,2) } c_{12} = 11 - (r_1 + c_2) = 11 - 9 = 2$$

$$\text{For cell (1,3) } c_{13} = 15 - (r_1 + c_3) = 15 - 11 = 4$$

$$\text{For cell (2,2) } c_{22} = 7 - (r_2 + c_2) = 7 - 15 = -8^*$$

$$\text{For cell (3,1) } c_{31} = 11 - (r_3 + c_1) = 11 - 5 = 6$$

Step 5

The negative value in asterisk implies we have to do some transfer to cell (2,2) while ensuring that the supply and demand quantities are kept constant and no other empty cell

expect (2,2) is given allocation. We must also ensure that the $m + n - 1$ criterion is maintained to avoid degeneracy. We obtain the table below.

	1	2	3	Supply
X	9	11	15	
	400	-	-	400
Y	15	7	17	
	100	-	400	500
Z	11	5	7	
	-	450	150	600
Demand	500	450	550	

$$\begin{aligned} \text{Cost} &= (400 \times 9) + (100 \times 15) + (400 \times 7) + (50 \times 5) + (550 \times 7) \\ &= 3600 + 1500 + 2800 + 250 + 3850 = 12000 \end{aligned}$$

Which is less than 15200. However, we need to check if this is an optimum value

Step 6

This is done by computing the c_{ij}^i and c_{ij}^i or the new table. If none of the c_{ij} is negative then it is the optimum value.

As before we get

For allocated cells

$$\begin{aligned} r_1 &= 0, & 1 + c_1 &= 9 & \therefore c_1 &= 9 \\ r_2 + c_1 &= 15 & & & \therefore r_2 &= 15 - 9 = 6 \\ r_2 + c_2 &= 7 & & & \therefore c_2 &= 7 - 6 = 1 \\ r_3 + c_2 &= 5 & & & \therefore r_3 &= 5 - 1 = 4 \\ r_3 + c_3 &= 7 & & & \therefore c_3 &= 7 - 4 = 3 \end{aligned}$$

We summarise and get the following

$$\begin{aligned} r_1 &= 0 & c_1 &= 9 \\ r_2 &= 6 & c_2 &= 1 \\ r_3 &= 4 & c_3 &= 3 \end{aligned}$$

For unallocated cells we have the following

For cell (1,2) we have $c_{12} = 11 - (r_1 + c_2) = 11 - 1 = 10$ for cell (1,3) we have $c_{13} = 15 - (r_1 + c_3) = 15 - 13 = 2$

For cell (1,3) we have $c_{13}^i = 15 - (r_1 + c_3) = 15 - 13 = 2$

For cell (2,3) we have $c_{23}^i = 17 - (r_2 + c_3) = 17 - (6+3) = 17 - 9 = 8$

For cell (3,1) we have $c_{31}^i = 11 - (r_3 + c_1) = 11 - (4 + 9) = 11 - 13 = -2^*$

Since (3,1) has negative c_{31}^i value of -2 we do some transfer to (3,1) in the usual manner together.

	1	2	3	Supply
X	9 400	11 -	15 -	400
Y	15 50	7 450	17	500
Z	11 50	5	7 550	600
Demand	500	450	550	

$$\text{Cost} = (400 \times 9) + (50 \times 15) + (50 \times 11) + (450 \times 7) + (550 \times 7)$$

$$= 3600 + 750 + 550 + 3150 + 3850 = 11,900$$

We check if this is the optimum solution by computing the differences in the unit costs and unit shadow costs c_{ij} in the usual way.

For allocated cells

$$r_1 = 0, \quad 1 + c_1 = 9 \quad \therefore c_1 = 9$$

$$r_2 + c_1 = 15 \quad \therefore r_2 = 15 - 9 = 6$$

$$r_2 + c_2 = 7 \quad \therefore c_2 = 7 - 6 = 1$$

$$r_3 + c_1 = 11 \quad \therefore r_3 = 11 - 9 = 2$$

$$r_3 + c_3 = 7 \quad \therefore c_3 = 7 - r_3 = 7 - 2 = 5$$

We summarize and get

$$r_1 = 0 \quad c_1 = 9$$

$$r_2 = 6 \quad c_2 = 1$$

$$r_3=2 \quad c_3=5$$

For unallocated cells

$$\text{for (1,2) we have } c_{12} = 11 - (0+1) = 10$$

$$\text{for (1,3) we have } c_{13} = 15 - (0+5) = 10$$

$$\text{for (2,3) we have } c_{23} = 17 - (6+5) = 6$$

$$\text{for cell (3,2) we have } c_{32} = 5 - (2 + 1) = 2$$

Since all these values are positive then the last table is the optimum assignment.

The optimum assignment is thus

	1	2	3	Supply
X	400	-	-	400
Y	50	450	-	500
Z	50	-	550	600
Demand	500	450	550	

The optimum cost is N11,900

We observe that the value obtained is the same as that of Vogel's Approximation method so Vogel is the best of all the methods.

3.10 DEGENERACY

This condition arises when the number of allocated cell does not satisfy the $m + n - 1$ criterion Degeneracy prevents us from utilizing the optimisation technique to get the minimization cost of the transportation model.

Exanp1e 10

Find the initial feasible solution of the transportation problem below using the Vogel s Approximation Method. Comment on your result.

	1	2	3	Supply
X	8	7	6	40
Y	16	10	9	120
Z	19	18	12	90
Demand	130	15	25	

Solution

	1	2	3	Supply	d ₁	d ₂	d ₃
X	8 40	7 -	6 -	400	1	-	-
Y	16 -	10 95	9 25	25 120	1	1	1
Z	19 90	18 -	12 -	90	6	6	7
Demand	130	15	25				
d ₁	8*	3	3				
d ₂	3	8*	3				
d ₃	3	-	3				

Correct: Only 4 cells are allocated. So degeneracy occurs.

The feasible solution can be obtained as follows

$$40 \times 8 = 320$$

$$95 \times 10 = 950$$

$$90 \times 19 = 1710$$

$$25 \times 9 = 225$$

N3,205

Let us compute the shadow costs

By convention $r_1 = 0$

$$r_1 + c_1 = 8 \quad \therefore r_1 = 8$$

$$r_2 + c_2 = 10$$

$$r_2 + c_3 = 9$$

$$r_3 + c_1 = 19 \quad \therefore r_3 = 19 - 8 = 11$$

Due to degeneracy we cannot get enough information to enable us calculate r_+ , c_+ and c_3 . This implies that we cannot determine the needed row and column values for the unallocated cells.

The way out is to create a dummy allocated cell which is assigned a value of 0. Others advocate adding a small value to an empty cell and then proceeding with using MODI to obtain the optimum solution in the usual way.

4.0 CONCLUSION

The transportation problem is only a special topic of the linear programming problems. It would be a rare instance when a linear programming problem would actually be solved by hand. There are too many computers around and too many LP software programs to justify spending time for manual solution. (There are also programs that assist in the construction of the LP or TP model itself. Probably the best known is GAMS—General Algebraic Modeling System (GAMS-General, San Francisco, CA). This provides a high-level language for easy representation of complex problems.)

SUMMARY

The transportation model deals with a special class of linear programming problem in which the objective is to transport a homogeneous commodity from various origins or factories to different destinations or markets at a total minimum cost. In this unit, we discussed the following issues- assumptions of the transportation model which include the Homogeneity of materials to be transported, equality of transportation cost per unit, uniqueness of route or mode of transportation between each source and destination. It also discussed extensively, various methods of solving the transportation problem viz: the North West corner method, the least cost method, Vogel's approximation method (VAM), the unbalanced case, formulating linear programming model for the transportation problem, and determination of the optimal transportation cost using the stepping stone method.

5.0 TUTOR MARKED ASSIGNMENT

1. Give four assumptions of the transportation model.
2. Present a theoretical consideration of the transportation model
3. List three methods used in developing a transportation solution.
4. In the table below, items supplied from origins A, B, C and D and those demanded in locations 1, 2, 3 and 4 are shown. If the figures in the boxes are the unit cost of moving an item from an origin to a destination, use the least cost method to allocate the material in order to minimize cost of transportation.

Destination

Origin	1	2	3	4	Supply
A	29	41	25	46	1250
B	50	27	45	33	2000
C	43	54	49	40	500
D	60	38	48	31	2750
Demand	3250	250	1750	1250	

6.0 REFERENCES

- Murthy, R.P. (2007). Operations Research 2nd ed. New Delhi: New Age International Publishers.
- Dixon – Ogbechi, B.N. (2001). Decision Theory in Business, Lagos: Philglad Nig. Ltd.
- Denardo, E.V. (2002). The Schience of Decision making: A Problem-Based Approach Using Excel. New York: John Wiley.
- Gupta, P.K., and Hira, D.S. (2012). Operations Research, New – Delhi: S. Chand & Company.
- Lucey, T. (1988). Quantitative Techniques: An Instructional Manual, London: DP Publications.

UNIT 3: ASSIGNMENT MODEL

- 1.0 Introduction
- 2.0 Objectives
- 3.0 Main Content
 - 3.1 The Problem
 - 3.2 Comparison between Transportation Problem and Assignment Problem
 - 3.3 Approach to Solution
- 4.0 Conclusion
- 5.0 Summary
- 6.0 Tutor Marked Assignment
- 7.0 References

1.0 INTRODUCTION

The assignment problem is a special type of linear programming problem. We know that linear programming is an allocation technique to optimize a given objective. In linear programming we decide how to allocate limited resources over different activities so that, we maximize the profits or minimized the cost.

Similarly in assignment problem, assignees are being assigned to perform different task. For example, the assignees can be employees who need to be given work assignments, is a common application of assignment problem. However assignees need not be people. They could be machines, vehicle, plants, time slots etc. to be assigned different task.

2.0 OBJECTIVE

After reading this unit, you should be able to

- Identify types of assignment problems,
- Draw a comparison between an assignment and a transportation problem.
- Use the different solution techniques to solve assignment problems.

3.1 The Problem

There are various types in assignment problem. They are:

(i) Assigning the jobs to machines when the problem has square matrix to minimize the time required to complete the jobs. Here the number of rows *i.e.* jobs are equals to the number of machines *i.e.* columns. The procedure of solving will be discussed in detail in this section.

(ii) The second type is maximization type of assignment problem. Here we have to assign certain jobs to certain facilities to maximize the returns or maximise the effectiveness.

(iii) Assignment problem having non-square matrix. Here by adding a dummy row or dummy columns as the case may be, we can convert a non-square matrix into a square matrix and proceed further to solve the problem. This is done in problem number.5.9.

(iv) Assignment problem with restrictions. Here restrictions such as a job cannot be done on a certain machine or a job cannot be allocated to a certain facility may be specified. In such cases, we should neglect such cell or give a high penalty to that cell to avoid that cell to enter into the programme.

(v) Travelling sales man problem (cyclic type). Here a salesman must tour certain cities starting from his hometown and come back to his hometown after visiting all cities. This type of problem can be solved by Assignment technique and is solved in problem 5.14. Let us take that there are 4 jobs, *W*, *X*, *Y* and *Z* which are to be assigned to four machines, *A*, *B*, *C* and *D*. Here all the jobs have got capacities to machine all the jobs. Say for example that the job *W* is to drill a half and inch hole in a Wooden plank, Job *X* is to drill one inch hole in an Aluminium plate and Job *Y* is to drill half an inch hole in a Steel plate and job *Z* is to drill half an inch hole in a Brass plate.

The machine *A* is a Pillar type of drilling machine, the machine *B* is Bench type of drilling machine, Machine *C* is radial drilling machine and machine *D* is an automatic

drilling machine. This gives an understanding that all machines can do all the jobs or all jobs can be done on any machine. The cost or time of doing the job on a particular machine will differ from that of another machine, because of overhead expenses and machining and tooling charges. The objective is to minimize the time or cost of manufacturing all the jobs by allocating one job to one machine. Because of this character, *i.e.* one to one allocation, the assignment matrix is always a square matrix. If it is not a square matrix, then the problem is unbalanced. Balance the problem, by opening a dummy row or dummy column with its cost or time coefficients as zero. Once the matrix is square, we can use assignment algorithm or Flood's technique or Hungarian method to solve the problem.

Mathematical Model:

<i>Jobs</i>	<i>Machine Time (hours)</i>				<i>Availability</i>
	<i>A</i>	<i>B</i>	<i>C</i>	<i>D</i>	
<i>W</i>	<i>C11</i>	<i>C12</i>	<i>C13</i>	<i>C14</i>	<i>1</i>
<i>X</i>	<i>C21</i>	<i>C22</i>	<i>C23</i>	<i>C24</i>	<i>1</i>
<i>Y</i>	<i>C31</i>	<i>C32</i>	<i>C33</i>	<i>C34</i>	<i>1</i>
<i>Z</i>	<i>C41</i>	<i>C42</i>	<i>C43</i>	<i>C44</i>	<i>1</i>
<i>REQUIREMENT</i>	<i>1</i>	<i>1</i>	<i>1</i>	<i>1</i>	

Mathematical Model:

$$\text{Minimize } Z = \sum_{i=1}^n \sum_{j=1}^n C_{ij}X_{ij} \text{ --- Objective Constraint}$$

Subject to: $X_{ij} = (X_{ij})_{2i}$ and $j = 1$ to n

$$\sum_{j=1}^n X_{ij} = 1(d_j) \text{ and } \sum_{i=1}^n X_{ij} = 1(b_i) \text{ ----- structural constraint}$$

(Each machine to one job only)

For i and $j = 1$ to n

(Each job to one machine only)

And

$X_{ij} = 0$ for all values of j and i . Non-negativity constraint.

3.2 COMPARISON BETWEEN TRANSPORTATION PROBLEM AND ASSIGNMENT PROBLEM

Now let us see what are the similarities and differences between Transportation problem and Assignment Problem.

Similarities

1. Both are special types of linear programming problems.
2. Both have objective function, structural constraints, and non-negativity constraints. And the relationship between variables and constraints are linear.
3. The coefficients of variables in the solution will be either 1 or zero in both cases.
4. Both are basically minimization problems. For converting them into maximization problem same procedure is used.

Fig11.1: Difference between transportation and Assignment models.

Differences

<i>Transportation Problem</i>	<i>Assignment Problem.</i>
1. The problem may have rectangular matrix or square matrix.	1.The matrix of the problem must be a square matrix.
2.The rows and columns may have any number of allocations depending on the rim conditions.	2.The rows and columns must have one to one allocation. Because of this property, the matrix must be a square matrix.
3.The basic feasible solution is obtained by northwest corner method or matrix minimum method or VAM	3.The basic feasible solution is obtained by Hungarian method or Flood's technique or by Assignment algorithm.
4.The optimality test is given by stepping stone method or by MODI method.	4.Optimality test is given by drawing minimum number of horizontal and vertical lines to cover all the zeros in the matrix.
5.The basic feasible solution must have $m + n - 1$ allocations.	5.Every column and row must have at least one zero. And one machine is
6.The rim requirement may have any numbers (positive numbers).	
7.In transportation problem, the problem	

deals with one commodity being moved from various origins to various destinations	assigned to one job and vice versa. 6. The rim requirements are always 1 each for every row and one each for every column. 7. Here row represents jobs or machines and columns represents machines or jobs.
---	---

Source: Murthy, Rama P. (2007) *Operations Research 2nd ed.* New Delhi: New Age International Publishers

3.3 APPROACHES TO SOLUTION

Let us consider a simple example and try to understand the approach to solution and then discuss complicated problems.

1. Solution by visual method

In this method, first allocation is made to the cell having lowest element. (In case of maximization method, first allocation is made to the cell having highest element). If there is more than one cell having smallest element, tie exists and allocation may be made to any one of them first and then second one is selected. In such cases, there is a possibility of getting alternate solution to the problem. This method is suitable for a matrix of size 3×4 or 4×4 . More than that, we may face difficulty in allocating.

Problem 5.1.

There are 3 jobs A, B, and C and three machines X, Y, and Z. All the jobs can be processed on all machines. The time required for processing job on a machine is given below in the form of matrix. Make allocation to minimize the total processi

Machines (time in hours)

Jobs	X	Y	Z
A	11	16	21
B	20	13	17
C	13	15	12

Allocation: A to X, B to Y and C to Z and the total time = $11 + 13 + 12 = 36$ hour (Since 11 is least, Allocate A to X, 12 is the next least, Allocate C to Z)

2. Solving the assignment problem by enumeration

Let us take the same problem and workout the solution.

Machines (time in hours)

Jobs	X	Y	Z
A	11	16	21

B	20	13	17
C	13	15	12

S/N	Assignment	Total Cost in ₦
1	AX BY CZ	$11 + 13 + 12 = 36$
2	AX BZ CY	$11 + 17 + 15 = 43$
3	AY BX CZ	$16 + 20 + 12 = 48$
4	AY BZ CX	$16 + 17 + 13 = 46$
5	AZ BY CX	$21 + 13 + 13 = 47$
6	AZ BX CY	$21 + 20 + 15 = 56$

Like this we have to write all allocations and calculate the cost and select the lowest one. If more than one assignment has same lowest cost then the problem has alternate solutions.

3. Solution by Transportation method

Let us take the same example and get the solution and see the difference between transportation problem and assignment problem. The rim requirements are 1 each because of one to one allocation

Machines (Time in hours)

<i>Jobs</i>	<i>X</i>	<i>Y</i>	<i>Z</i>	<i>Available</i>
A	11	16	21	1
B	20	13	17	1
C	13	15	12	1
Req.	1	1	1	3

By using northwest corner method the assignments are:

Machines (Time in hours)

<i>Jobs</i>	<i>X</i>	<i>Y</i>	<i>Z</i>	<i>Available</i>
A	1	E		1

B		1	€	1
C			1	1
Req.			1	3

As the basic feasible solution must have $m + n - 1$ allocation, we have to add 2 epsilons. Next we have to apply optimality test by MODI to get the optimal answer.

4.0 CONCLUSION

For solving the assignment problem we use Assignment technique or Hungarian method or Flood's technique. All one are the same. Above, it is mentioned that one origin is to be assigned to one destination. This feature implies the existence of two specific characteristics in linear programming problems, which when present, give rise to an assignment problem. The first one being the pay of matrix for a given problem is a square matrix and the second is the optimum solution (or any solution with given constraints) for the problem is such that there can be one and only one assignment in a given row or column of the given payoff matrix.

5.0 SUMMARY

Assignment problems involve matching the elements of two or more sets in such a way that some objective function is optimized. Hungarian Method algorithm for its solution, the classic AP, which involves matching the elements of two sets on a one-to-one basis so as to minimize the sum of their associated weights, has spawned a wide variety of derivatives, including problems with different or multiple objectives, problems that involve one-to-many or many-to-one matching, and problems that involve matching the elements of three or more sets

6.0 TUTOR MARKED ASSIGNMENT

1. List and explain five types of assignment problems.
2. Give three similarities between an assignment problem and a transportation problem.
3. Highlight the differences between an assignment problem and a transportation problem.

7.0 REFERENCES

- Murthy, R.P. (2007). Operations Research 2nded. New Delhi: New Age International Publishers.
- Denardo, E.V. (2002). The Schience of Decision making: A Problem-Based Approach Using Excel. New York: John Wiley.

- Gupta, P.K., and Hira, D.S. (2012). Operations Research, New – Delhi: S. Chand & Company.
- Lucey, T. (1988). Quantitative Techniques: An Instructional Manual, London: DP Publications.

UNIT 4: PROJECT MANAGEMENT

- 1.0 Introduction
- 2.0 Objectives
- 3.0 Main Content
 - 3.1 What is Project Management?
 - 3.2 International Standards and Guidelines
 - 3.3 Project Management Processes
 - 3.4 Project vs. Product Life Cycles
 - 3.5 What is the Value of Project Management?
 - 3.6 How Project Management Relates to Other Disciplines
 - 3.7 The Project Management Profession
 - 3.8 Project Planning
 - 3.9 Programme Evaluation and Review Technique and Critical Path Method (PERT and CPM)
- 4.0 Conclusion
- 5.0 Summary

- 6.0 Tutor Marked Assignment
- 7.0 References

1.0 INTRODUCTION

This unit is designed to introduce you to the basic concepts and definitions associated with project management. You will learn about the triple constraints of scope, time and cost; the nine functional knowledge areas associated with project management and the four major phases of a project. You will also learn about the skills and tools used to integrate all of the knowledge areas throughout a project's lifecycle. You will also learn how to use the CPM and PERT techniques in solving project related problems.

2.0 OBJECTIVES

At the end of this unit, you should be able to

- Define project management
- Identify the “body of knowledge areas” in project management.
- List and explain the processes involved in project management.
- Describe the project vs product cycle.

3.0 MAIN CONTENT

3.1 What is Project Management?

Project Management has been called an accidental profession. In many organisations in the past, project managers typically stumbled or fell into project management responsibilities. The world has since changed and project management is now recognised globally as a formal discipline, with international standards and guidelines and a growing knowledge base of best practices. Project management is the application of skills and knowledge and the use of tools and techniques applied to activities in a project to complete the project as defined in the scope. Project management is not only the use of a scheduling tool such as Microsoft Project, Scheduler Plus, etc. Many organisations still do not understand that the ability to use a scheduling tool is not enough to successfully manage a project. The use of a tool is only one part of the equation. Project management requires a high level of skill in both the people and technical side of the discipline for successful projects to result.

3.2 International Standards and Guidelines

Project Management is a formal discipline with international standards and guidelines developed by the Project Management Institute (PMI). A significant body of knowledge has been accumulated specifically over the past 5 years relating to effective project management practices, tools, techniques and processes across industries. PMI is recognised as the international body providing guidance and direction for the discipline. PMI has developed the “Project Management Body of Knowledge” or “PMBOK” the

essential knowledge areas and processes required to effectively manage projects. There are nine “body” of knowledge areas within the standards and guidelines.

- **Integration Management:** Processes to ensure that the elements of the project are effectively coordinated. Integration management involves making decisions throughout the project in terms of objectives and alternative approaches to meet or exceed stakeholder expectations.
- **Scope Management:** processes to ensure that all the work required to complete the project is defined. Defining what is or is not in scope.
- **Time Management:** all processes required to ensure that the project completes on time (defined schedule).
- **Quality Management:** processes to ensure that the project delivers the need for which it was undertaken. Includes all quality processes such as quality policy, objectives, and responsibility and implements these through quality planning, quality assurance, quality control and quality improvement.
- **Procurement Management:** processes to acquire goods and services for the project outside of the organisation.

3.3 Project Management Processes

Project Management processes define, organise and complete the work defined for the project. There are five project management process areas that apply to most projects and are defined in the PMBOK:

- **Initiating Processes:** authorising the project or phase.
- **Planning Processes:** defining the project objectives and selecting the most appropriate approach for the project to attain the objectives.
- **Executing Processes:** managing the resources required to carry out the project as defined in the plan.
- **Controlling Processes:** ensuring that project objectives are met as defined by monitoring, measuring progress against plan, identifying variance from plan and taking corrective action.

The following diagram is a sample of a standard four phase project life cycle.

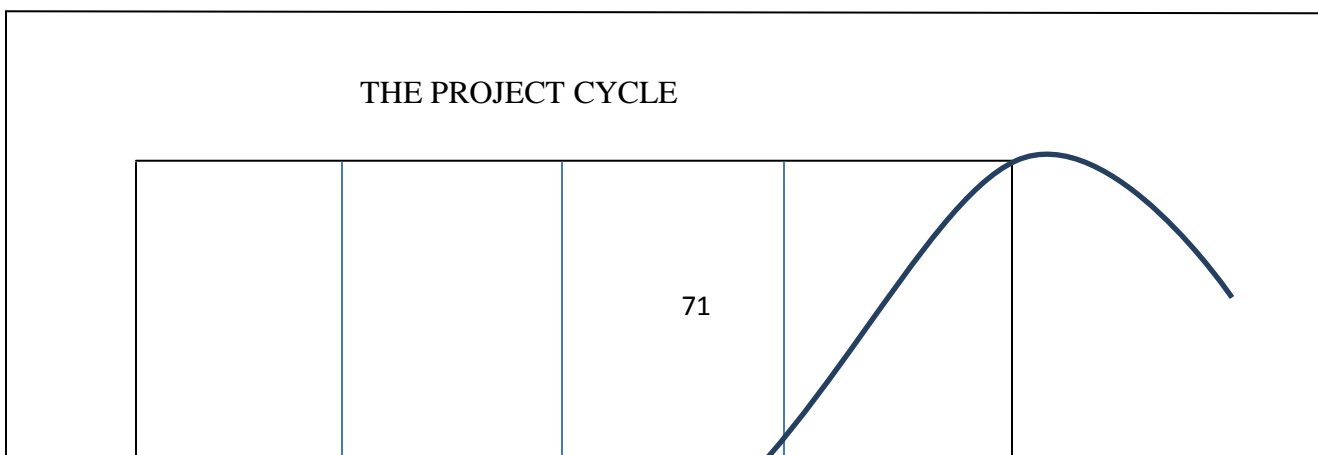

N

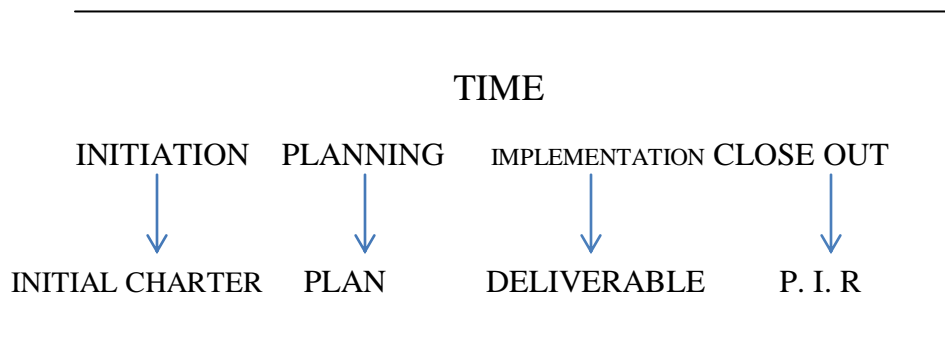

Fig. 1: The product cycle

3.4 Project Vs. Product Life Cycles

Those of you involved in information technology fields have likely heard of the systems development life cycle (SDLC) – a framework for describing the phases involved in developing and maintaining IT systems. This is an example of a **product** life cycle. The project life cycle applies to all projects (regardless of product produced) whereas a product life cycle varies depending on the nature of the product. Many products (such as large IT systems) are actually developed through a series of several different projects. Large projects are seldom given full funding and approval from the beginning. Usually a project has to successfully pass through each of the project phases before continuing to the next. The practice of ‘progressive resource commitment’ also means you only get the money for the next phase after the prior phase has been completed and there is an opportunity for management review to evaluate progress, probability of success and continued alignment with organisational strategy. These management points are often called *phase exits, killpoints or stage gates*.

3.5 What is the Value of Project Management?

Project Management increases the probability of project success. Project Management is change facilitation, and used effectively with appropriate processes, tools, techniques and skills will:

- Support the Business
- Get the product or service to market effectively, efficiently and to quality standards
- Provide common approach to project management
- Improve service

Project management is the application of knowledge, skills, tools, and techniques to project activities in order to meet or exceed stakeholder needs and expectations from a project.

3.6 How Project Management Relates to Other Disciplines

Project management overlaps with general management knowledge and practice, as well as with the project's application areas, knowledge, and practice. Project managers focus on integrating all the pieces required for project completion. General Managers or operational managers tend to focus on a particular discipline or functional area. In this respect, project management tends to be a cross-functional role, often involving people from various business areas and divisions. While project management requires some fundamental understanding of the knowledge area of the project itself, the project manager does not have to be an expert in that field.

3.7 The Project Management Profession

The Project Management Institute (PMI) provides certification as a project management professional (PMP). The requirements include verification of from 4500 to 7500 hours of project management experience (depending on education level), adherence to a Code of Ethics, and obtaining a score of 70% or higher on a 200-question multiple choice certification exam.

3.8 Project Planning

We are going to take a quick look at the elements of project planning, starting with the project life cycle and then examine the importance of detailed planning to the overall success of the project. Without a clear definition of the project, it's impossible to discern what should be delivered as a result. If requirements are not clear, your project will be impossible to control, and it will become unmanageable. We will review the fundamentals of planning and then move on to the importance of developing a comprehensive work breakdown structure.

Today's organisations are running at a fast pace. More so than ever, organisations are faced with increasing global competition and as such, want products and services delivered yesterday! Organisations are struggling with multiple projects, tight deadlines and fewer skilled resources available to manage these projects. Project managers are struggling with the concepts of best practices and the reality of life in a corporation.

Often, insufficient time is provided for planning the project appropriately and as a result projects consistently fail to produce the expected results, have cost or time overruns, or just plain fail. In such cases, the project manager can usually look back on his or her experiences and see what went wrong, vowing never to make the same mistake again. Sometimes, however, the cycle continues. Whether you manage a small, medium or large size project, effective planning of the project is the single most critical step to success. Too many project managers either neglect or spend too little time and effort planning. The tendency is to rush to implementation before a clear picture is developed. The following diagram illustrates the “Project Life Cycle” and the cyclical nature of planning activities.

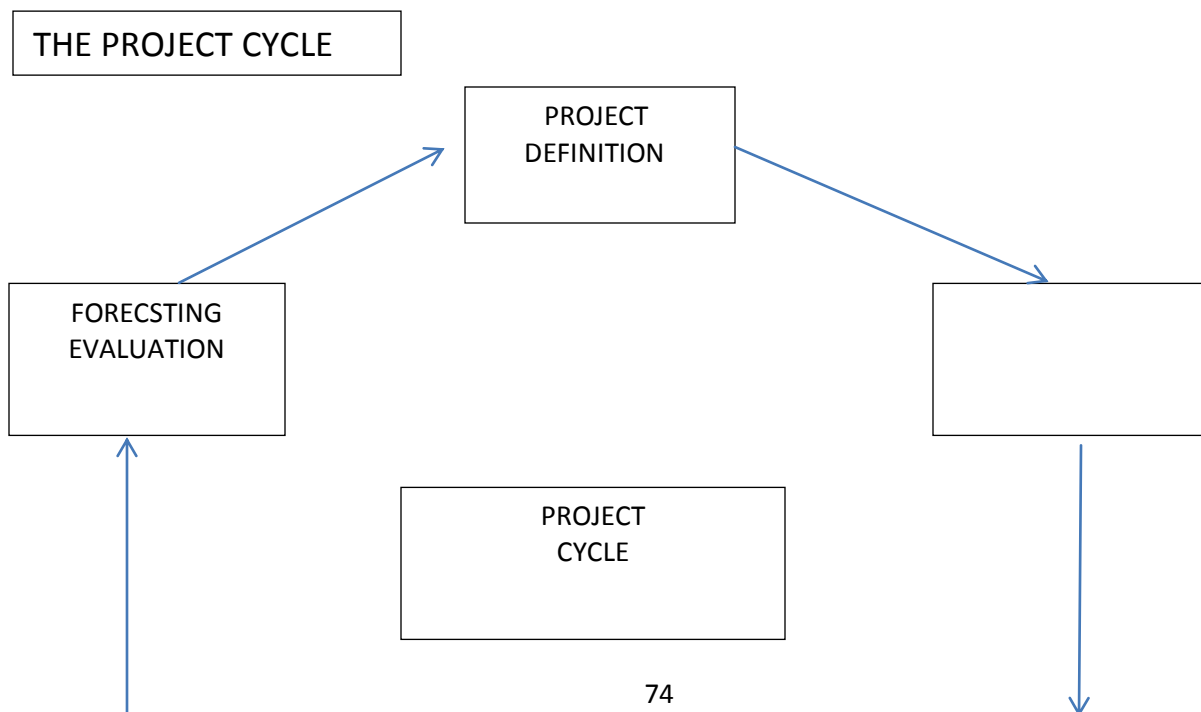

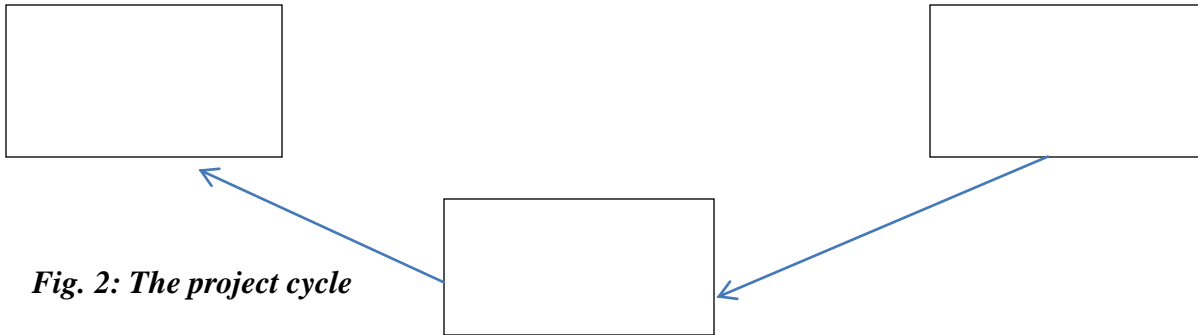

Fig. 2: The project cycle

3.9 PROGRAMME EVALUATION AND REVIEW TECHNIQUE AND CRITICAL PATH METHOD (PERT AND CPM)

Programme Evaluation and Review Technique (PERT) and Critical Path Method (CPM) are two techniques that are widely used in planning and scheduling the large projects. A project is a combination of various activities. For example, Construction of a house can be considered as a project. Similarly, conducting a public meeting may also be considered as a project. In the above examples, construction of a house includes various activities such as searching for a suitable site, arranging the finance, purchase of materials, digging the foundation, construction of superstructure etc. Conducting a meeting includes, printing of invitation cards, distribution of cards, arrangement of platform, chairs for audience etc. In planning and scheduling the activities of large sized projects, the two network techniques — PERT and CPM — are used conveniently to estimate and evaluate the project completion time and control there sources to see that the project is completed within the stipulated time and at minimum possible cost. Many managers, who use the PERT and CPM techniques, have claimed that these techniques drastically reduce the project completion time. But it is wrong to think that network analysis is a solution to all bad management problems. In the present chapter, let us discuss how PERT and CPM are used to schedule the projects. Initially, projects were represented by **milestone chart** and **bar chart**. But they had little use in controlling the project activities. **Bar chart** simply represents each activity by bars of length equal to the time taken on a common time scale as shown in figure 15. 1. This chart does not show interrelationship between activities. It is very difficult to show the progress of work in these charts. An improvement in bar charts is **milestone chart**. In milestone chart, key events of activities are identified and each activity is connected to its preceding and succeeding activities to show the logical relationship between activities. Here each key event is represented by a node (a circle) and arrows instead of bars represent activities, as shown in figure the figures below. The extension of milestone chart is PERT and CPM network methods.

Y

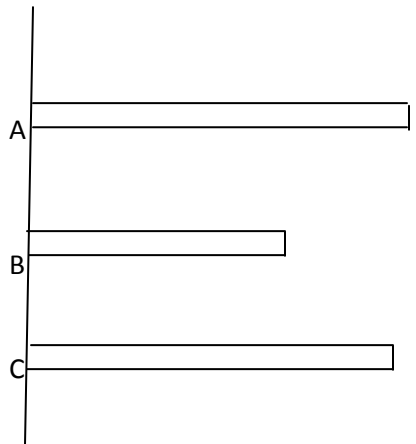

Fig. 3a: Bar Chart

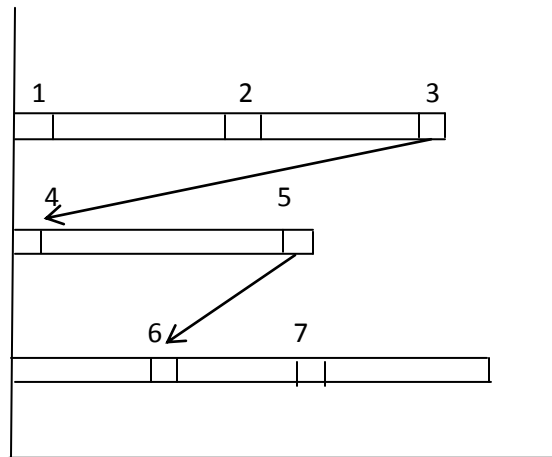

Fig. 3b: Milestone Chart.

In PERT and CPM the milestones are represented as *events*. Event or node is either starting of an activity or ending of an activity. Activity is represented by means of an arrow, which is resource consuming. Activity consumes resources like time, money and materials. Event will not consume any resource, but it simply represents either starting or ending of an activity. Event can also be represented by rectangles or triangles. When all activities and events in a project are connected logically and sequentially, they form a *network*, which is the basic document in network-based management. The basic steps for writing a network are:

(a) List out all the activities involved in a project. Say, for example, in building construction, the activities are:

- (i) Site selection,
- (ii) Arrangement of Finance,
- (iii) Preparation of building plan,
- (iv) Approval of plan by municipal authorities,
- (v) Purchase of materials,

(b) Once the activities are listed, they are arranged in sequential manner and in logical order. For example, foundation digging should come before foundation filling and so on. Programme Evaluation and Review Technique and Critical Path Method (PERT and CPM)

(c) After arranging the activities in a logical sequence, their time is estimated and written against each activity. For example: Foundation digging: 10 days, or 1½ weeks.

(d) Some of the activities do not have any logical relationship, in such cases; we can start those activities simultaneously. For example, foundation digging and purchase of materials do not have any logical relationship. Hence both of them can be started simultaneously. Suppose foundation digging takes 10 days and purchase of materials takes 7 days, both of them can be finished in 10 days. And the successive activity, say

foundation filling, which has logical relationship with both of the above, can be started after 10 days. Otherwise, foundation digging and purchase of materials are done one after the other; filling of foundation should be started after 17 days.

(e) Activities are added to the network, depending upon the logical relationship to complete the project network.

Some of the points to be remembered while drawing the network are

(a) There must be only one beginning and one end for the network, as shown in figures bellow.

(b)

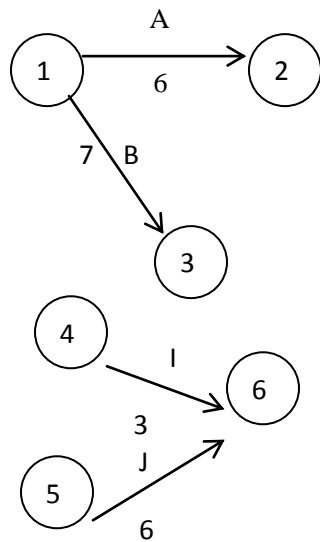

RIGHT

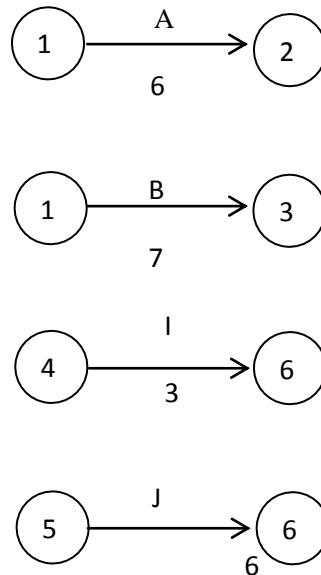

WRONG

Fig. 4: Writing the network.

(c) Event number should be written inside the circle or node (or triangle/square/rectangle etc). Activity name should be capital alphabetical letters and would be written above the arrow. The time required for the activity should be written below the arrow as in the figure below.

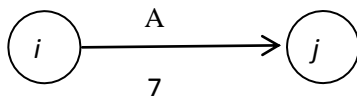
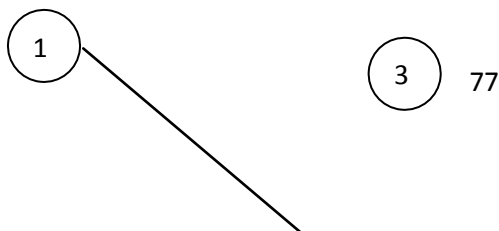
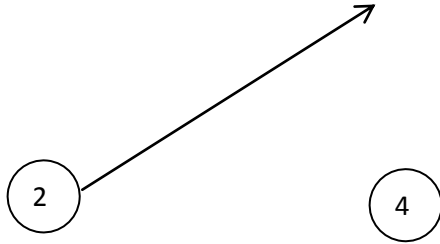

Fig 5: Numbering and naming the activities.

(d) While writing network, see that activities should not cross each other. And arcs or loops as in figures above should not join Activities.





WRONG

Fig .6: Crossing of activities not allowed

(d) While writing network, looping should be avoided. This is to say that the network arrows should move in one direction, *i.e.* starting from the beginning should move towards the end, as in figure 6.

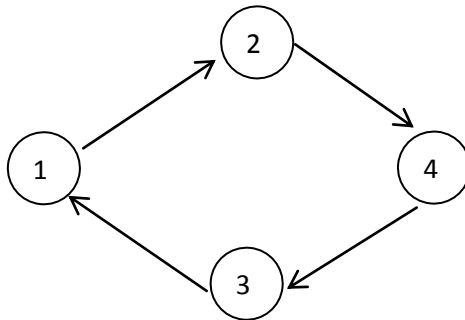

WRONG

Fig .7: Looping is not allowed.

(e) When two activities start at the same event and end at the same event, they should be shown by means of a **dummy activity** as in figure 7. Dummy activity is an activity, which simply shows the logical relationship and does not consume any resource. It should be represented by a dotted line as shown. In the figure, activities *C* and *D* start at the event 3 and end at event 4. *C* and *D* are shown in full lines, whereas the dummy activity is shown in dotted line.

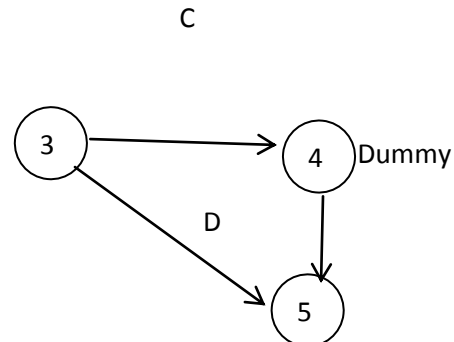
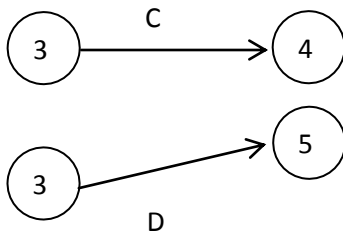

WRONG

RIGHT

Fig. 8: Use of Dummy activity.

(f) When the event is written at the tail end of an arrow, it is known as *tail event*. If event is written on the head side of the arrow it is known as *head event*. A tail event may have any number of arrows (activities) emerging from it. This is to say that an event may be a tail event to any number of activities. Similarly, a head event may be a head event for any number of activities. This is to say that many activities may conclude at one event. This is shown in figure 8.

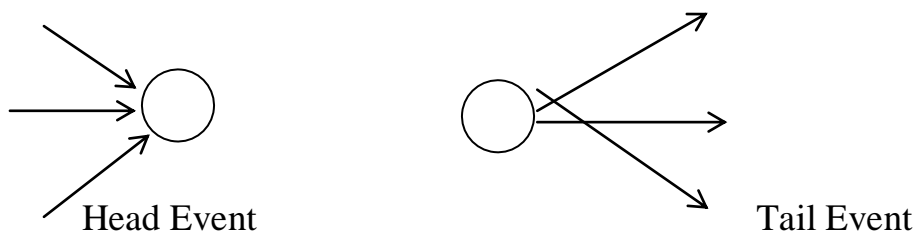

Fig 9: Tail event and Head event

The academic differences between PERT network and CPM network are:

(i) PERT is event oriented and CPM is activity oriented. This is to say that while discussing about PERT network, we say that Activity 1-2, Activity 2-3 and so on. Or event 2 occurs after event 1 and event 5 occurs after event 3 and so on. While discussing CPM network, we say that Activity A follows activity B and activity C follows activity B and so on. Referring to the network shown in figure 9, we can discuss as under. PERT way: Event 1 is the predecessor to event 2 or event 2 is the successor to event 1. Events 3 and 4 are successors to event 2 or event 2 is the predecessor to events 3 and 4. CPM way: Activity 1-2 is the predecessor to Activities 2-3 and 2-4 or Activities 2-3 and 2-4 are the successors to activity 1-2.

(ii) PERT activities are probabilistic in nature. The time required to complete the PERT activity cannot be specified correctly. Because of uncertainties in carrying out the activity, the time cannot be specified correctly. Say, for example, if you ask a contractor how much time it takes to construct the house, he may answer you that it may take 5 to 6 months. This is because of his expectation of uncertainty in carrying out each one of the activities in the construction of the house.

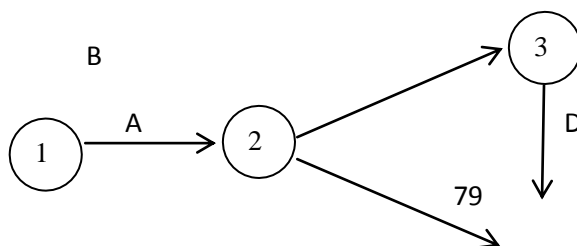

Fig 10. Logical relationship in PERT and CPM

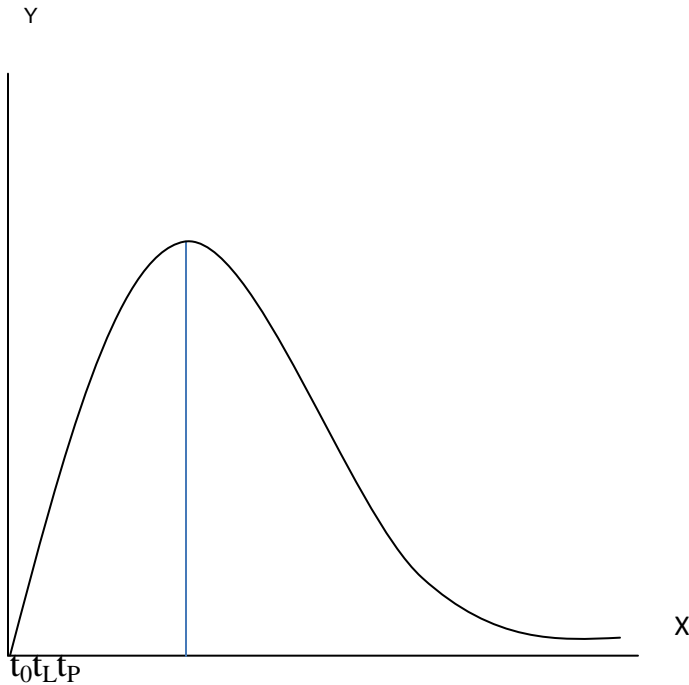

Fig. 11: Three Time Estimates.

There are three time estimates in PERT, they are:

(a) **OPTIMISTIC TIME:** Optimistic time is represented by t_0 . Here the estimator thinks that everything goes on well and he will not come across any sort of uncertainties and estimates lowest time as far as possible. He is optimistic in his thinking.

(b) **PESSIMISTIC TIME:** This is represented by t_p . Here estimator thinks that everything goes wrong and expects all sorts of uncertainties and estimates highest possible time. He is pessimistic in his thinking.

(c) **LIKELY TIME:** This is represented by t_L . This time is in between optimistic and pessimistic times. Here the estimator expects he may come across some sort of uncertainties and many a time the things will go right. So while estimating the time for a PERT activity, the estimator will give the three time estimates. When these three estimates are plotted on a graph, the probability distribution that we get is closely associated with **Beta Distribution curve**. For a Beta distribution curve as shown in figure 6.10, the characteristics are:

Standard deviation = $(t_P - t_O)/6 = \sigma$, $t_P - t_O$ is known as range.

Variance = $\{(t_P - t_O)/6\}^2 = \sigma^2$

Expected Time or Average Time = $t_E = (t_O + 4t_L + t_P) / 6$

These equations are very important in the calculation of PERT times. Hence the student has to remember these formulae. Now let us see how to deal with the PERT problems.

(d) **Numbering of events:** Once the network is drawn the events are to be numbered. In PERT network, as the activities are given in terms of events, we may not experience difficulty. Best in case of CPM network, as the activities are specified by their name, is we have to number the events. For numbering of events, we use D.R. Fulkerson's rule.

Example 1.

A project consists of 9 activities and the three time estimates are given below. Find the project completion time (TE).

1. Write the network for the given project and find the project completion time?

Activities

Activities		Days		
<i>I</i>	<i>j</i>	T_0	T_L	T_P
10	20	5	12	17
10	30	8	10	13
10	40	9	11	12
20	30	5	8	9
20	50	9	11	13
40	60	14	18	22
30	70	21	25	30
60	70	8	13	17
60	80	14	17	21
70	80	6	9	12

Solution

In PERT network, it is easy to write network diagram, because the successor and predecessor or event relationships can easily be identified. While calculating the project completion time, we have to calculate t_e i.e. expected completion time for each activity from the given three-time estimates. In case we calculate project completion time by using t_0 or t_l or t_p separately, we will have three completion times. Hence it is advisable to calculate t_e expected completion time for each activity and then the project completion time. Now let us work out expected project completion time.

		81				
--	--	----	--	--	--	--

Predecessor event	Successor event	Time in days		$T_E =$ $(t_o + 4t_L + t_P)/6$		Range $(t_P - t_o)/6$	S.D. (σ) σ^2	Variance
10	20	5	12	17	9.66 (10)	12	2	4
10	30	8	10	13	10.17 (10)	5	0.83	0.69
10	40	9	11	12	10.83 (11)	3	0.5	0.25
20	30	5	8	9	7.67 (8)	4	0.66	0.44
20	50	9	11	13	11.00 (11)	4	0.66	0.44
40	60	14	18	22	18.00 (18)	8	1.33	1.78
30	70	21	25	30	25.18 (25)	9	1.5	2.25
60	70	8	13	17	12.83 (13)	9	1.5	2.25
50	80	14	17	21	17.17 (17)	7	1.16	1.36
70	80	6	9	12	9.00 (9)	6	1.0	1.0

For the purpose of convenience the t_E got by calculation may be rounded off to nearest whole number (the same should be clearly mentioned in the table). The round off time is shown in brackets. In this book, in the problems, the decimal, will be rounded off to nearest whole number. To write the network program, start from the beginning *i.e.* we have 10 – 20, 10 – 30 and 10 – 40. Therefore from the node 10, three arrows emerge. They are 10 – 20, 10 – 30 and 10 – 40. Next from the node 20, two arrows emerge and they are 20 – 30 and 20 – 50. Likewise the network is constructed. The following convention is used in writing network in this book.

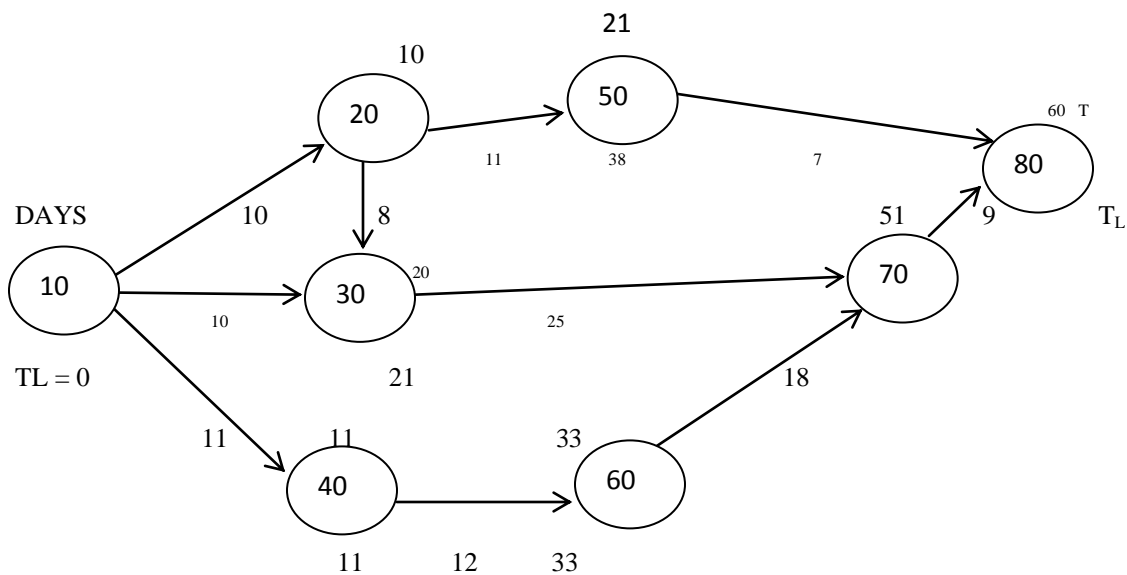

Fig: 12. Network for Problem

Let us start the event 10 at 0th time *i.e.* expected time $TE = 0$. Here TE represents the occurrence time of the event, whereas tE is the duration taken by the activities. TE belongs to event, and tE belongs to activity.

$$\begin{aligned} T_E^{10} &= 0 \\ T_E^{20} &= T_E^{10} + t_E^{10-20} = 0 + 10 = 10 \text{ days} \\ T_E^{30} &= T_E^{10} + t_E^{10-30} = 0 + 10 = 10 \text{ days} \\ T_E^{30} &= T_E^{20} + t_E^{20-30} = 10 + 8 = 18 \text{ days} \end{aligned}$$

The event 30 will occur only after completion of activities 20–30 and 10–30. There are two routes to event 30. In the **forward pass** *i.e.* when we start calculation from 1st event and proceed through last event, we have to workout the times for all routes and select the **highest one** and the **reverse** is the case of the **backward pass** *i.e.* we start from the last event and work back to the first event to find out the occurrence time.

$$\begin{aligned} T_E^{40} &= T_E^{10} + t_E^{10-40} = 0 + 11 = 11 \text{ days} \\ T_E^{50} &= T_E^{20} + t_E^{20-50} = 10 + 11 = 21 \text{ days} \\ T_E^{60} &= T_E^{40} + t_E^{40-60} = 11 + 18 = 29 \text{ days} \\ T_E^{70} &= T_E^{30} + t_E^{30-70} = 18 + 25 = 43 \text{ days} \\ T_E^{70} &= T_E^{60} + t_E^{60-70} = 29 + 13 = 42 \text{ days} \\ T_E^{80} &= T_E^{70} + t_E^{70-80} = 43 + 9 = 52 \text{ days} \\ T_E^{80} &= T_E^{50} + t_E^{50-80} = 21 + 17 = 38 \text{ days} \end{aligned}$$

$T_E^{80} = 52$ days. Hence the project completion time is 52 days. The path that gives us 52 days is known as **Critical path**. Hence 10–20–30–70–80 is the critical path. Critical path is represented by a hatched line (---|---|). All other parts *i.e.* 10–40–60–70–80, 10–20–50–80 and 10–30–70–80 are known as **non-critical paths**. All activities on critical path are **critical activities**.

4.0 CONCLUSION

In this unit, we have discussed the definition of project management, project management processes, PERT and CPM.

5.0 SUMMARY

This unit is a foundation unit in our study of project management. It tries to provide a starting point for our discussions on the key aspects of our study of project management.

6.0 TUTOR MARKED ASSIGNMENT

1. Define project management.
2. Discuss the interrelationship between project management and other disciplines.

3. Identify and explain the five project management process areas that apply to most projects.
4. Differentiate between PERT and CPM.

7.0 REFERENCES

- Murthy, R.P. (2007). Operations Research 2nd ed. New Delhi: New Age International Publishers.
- Denardo, E.V. (2002). The Science of Decision making: A Problem-Based Approach Using Excel. New York: John Wiley.
- Gupta, P.K., and Hira, D.S. (2012). Operations Research, New – Delhi: S. Chand & Company.
- Lucey, T. (1988). Quantitative Techniques: An Instructional Manual, London: DP Publications.

MODULE TWO

UNIT 1: ELEMENTS OF DECISION ANALYSIS

- 1.0 Introduction
- 2.0 Objectives
- 3.0 Main Content
 - 3.1 What is a Decision?
 - 3.2 Who is a Decision Maker?
 - 3.3 Decision Analysis
 - 3.4 Components of Decision Making
 - 3.4.1 Decision Alternatives
 - 3.4.2 States of Nature
 - 3.4.3 The Decision
 - 3.4.4 Decision Screening Criteria
 - 3.5 Phases of Decision Analysis

3.6	Errors that can occur in Decision Making
4.0	Conclusion
5.0	Summary
6.0	Tutor Marked Assignment
7.0	References

1.0 INTRODUCTION

Business Decision Analysis is the discipline comprising the philosophy, theory, methodology, and professional practice necessary to address important decisions in a formal manner. Decision analysis includes many procedures, methods, and tools for identifying, clearly representing, and formally assessing important aspects of a decision, for prescribing a recommended course of action by applying the maximum expected utility action axiom to a well-formed representation of the decision, and for translating the formal representation of a decision and its corresponding recommendation into insight for the decision maker and other stakeholders.

2.0 OBJECTIVES

By the end of this study unit, you should be able to:

- Define a decision
- Define a decision maker
- Describe the components of Decision making
- Outline the structure of a decision problem

3.0 MAIN CONENT

3.1 WHAT IS A DECISION?

A decision can be defined as an action to be selected according to some pre-specified rule or strategy, out of several available alternatives, to facilitate a future course of action. This definition suggests that there are several alternative courses of action available, which cannot be pursued at the same time. Therefore, it is imperative to choose the best alternative base on some specified rule or strategy.

3.2 WHO IS A DECISION MAKER?

A decision maker is one who takes decision. It could be an individual or a group of individuals. It is expected that a good decision maker should be skilled in art of making decisions.

3.3 DECISION ANALYSIS

Decision making is a very important and necessary aspect of every human endeavour. In life, we are faced with decision problems in everything we do. Individuals make decisions daily on what to do, what to wear, what to eat etc. Every human being is assumed to be a rational decision maker who takes decisions to improve his/her wellbeing. In business, management have to make decision on daily bases on ways to improve business performance. But unlike individual decision making, organizational or business decision making is a very complex process considering the various factors involved. It is easy to take decision for simple situation but when it gets complex, it is better not to rely on intuition. Decision theory proves useful when it comes to issues of risk and uncertainty (Adebayo et al 2010).

3.4 COMPONENTS OF DECISION MAKING

Earlier, we stated that complex decision problem involve risk and an uncertainty and as such, certain logic, rules, procedures should be applied when analysing such situation. The major components that constitute risk and uncertainty in decision making are:

- Decision alternatives
- States of Nature
- The decision itself
- Decision screening criteria

We now briefly discourse each of these components.

3.4.1 DECISION ALTERNATIVES

These are alternative courses of action available to the decision maker. The alternatives should be feasible, and evaluating them will depend on the availability of a well-defined objective. Alternative courses of action may also be seen as strategies or options from which the decision maker must choose from. It is due to the existence of several alternatives that the decision problem arises. If there were only one course of action, then there will be no decision problem.

Alternatives present themselves as:

- (a) Choices of products to manufacture,
- (b) Transportation roots to be taken,
- (c) Choice of customer to serve,
- (d) Financing option for a new project,
- (e) How to order job into machines, etc.

3.4.2. STATES OF NATURE

A state of nature is a future occurrence for which the decision maker has no control over. All the time a decision is made, the decision maker is not certain which states of nature will occur in future, and he has no influence over them (Taylor III, 2007). For instance, if a company has a contract to construct a 30km road, it may complete the construction of the full stretch of road in six months in line with a laid down plan. But this plan will be hinged on the possibility that it does not rain in the next six months. However, if there is consistent heavy rain for the first three months, it may delay the progress of work

significantly and as a result, prolong the completion date of the project. But if actually there is no occurrence of heavy rainfall, the company is likely to complete the road as scheduled.

3.4.3. THE DECISION

The decision itself is a choice which is arrived at after considering all alternatives available given an assumed future state of nature. In the view of Dixon-Ogbechi (2001), “A good decision is one that is based on logic, considers all available data, and possible alternative and employs quantitative technique” she further noted that, occasionally, a good decision may yield a bad result, but if made properly, may result in successful outcome in the long run.

3.4.4 DECISION SCREENING CRITERIA

In the section above, we mentioned that the decision itself is a choice which is arrived at after considering all other alternatives. Consideration of alternative courses of action is not done arbitrarily, it is done using some standardize logic or methodology, or criterion. These criteria form the basis upon which alternatives are compared. The strategy or alternative which is finally selected is the one associated with the most attractive outcome. The degree of attractiveness will depend on the objective of the decision maker and the criterion used for analysis (Ihemeje 2002).

IN TEXT QUESTION

- (1) Define a decision.
- (2) Who is a decision maker?
- (3) What do you understand by states of nature?
- (4) What is decision analysis?
- (5) List the two most prominent business objectives.

3.5 PHASES OF DECISION ANALYSIS

The process of analysing decision can be grouped into four phases. These four phases from what is known as the decision analysis cycle. They are presented as follows:

- **Deterministic Analysis Phase:** This phase accounts for certainties rather than uncertainties. Here, graphical and diagrammatic models like influence diagrams and flow charts can be translated into mathematical models. Necessary tools are used for predicting consequences of alternatives and for evaluating decision alternatives.
- **Probabilistic Analysis:** Probabilistic analyses cater for uncertainties in the decision making process. We can use the decision tree as a tool for probabilistic analysis.
- **Evaluation Phase:** At the phase, the alternative strategies are evaluated to enable one identify the decision outcomes that correspond to sequence of decisions and events.

3.6 ERRORS THAT CAN OCCUR IN DECISION MAKING

The following are possible errors to guide against when making decisions.

- Inability to identify and specify key objectives: Identifying specific objectives gives the decision maker a clear sense of direction.
- Focusing on the wrong problem: This could create distraction and will lead the decision maker to an inappropriate solution.
- Not giving adequate thoughts to trade-offs which may be highly essential to the decision making process.

4.0 CONCLUSION

Decision can be made either as single individuals or as group of individuals or as organizations. Those decisions are made in order to meet laid down goals and objectives which in most cases are aim to bring about improvement in fortunes.

5.0 SUMMARY

In this unit, the elements of decision analysis were discussed. It began with defining a decision, and who a decision maker is. Further, it considers the components of Decision making, structure of a decision problem and finally errors that can occur in decision making. This unit provides us with concepts that will help us in understanding the subsequent units and modules.

6.0 TUTOR MARKED ASSIGNMENT

- (1) Who is a Decision Maker?
- (2) Define Decision Analysis.
- (3) List and explain the components of decision.

7.0 REFERENCES

- Ackoff, R., and Sisieni, M. (1991). Fundamentals of Operations Research, New York: John Wiley and Sons Inc.
- Adebayo, O.A., Ojo, O., and Obamire, J.K. (2006). Operations Research in Decision Analysis, Lagos: Pumark Nigeria Limited.
- Churchman, C.W. et al (1957). Introduction to Operations Research, New York: John Wiley and Sons Inc.
- Howard, A. (2004). Speaking of Decisions: Precise Decision Language. Decision Analysis, Vol. 1 No. 2, June).
- Ihemeje, J.C. (2002). Fundamentals of Business Decision Analysis, Ibadan: Sibon Books Limited.
- Shamrma, J.K. (2009). Operations Research Theory & Application

UNIT 2: APPROACHES TO DECISION ANALYSIS

- 1.0 Introduction
- 2.0 Objectives
- 3.0 Main Content
 - 3.1 Main Approaches to Decision Analysis
 - 3.1.1 Qualitative Approach to Decision Making
 - 3.1.2 Quantitative Approach
 - 3.2 Objective of Decision Making
 - 3.3 Steps in Decision Theory Approach
 - 3.4 Decision Making Criteria
 - 3.4.1 Maximax Criterion (Criterion of Optimism)
 - 3.4.2 Maximin Criterion (Criterion of Pessimism)
 - 3.4.3 Minimax Regret Criterion (Savage Criterion)
 - 3.4.4 Equally Likely of Laplace Criterion (Bayes' or Criterion of Rationality)
 - 3.4.5 Hurwicz Criterion (Criterion of Realism)
- 4.0 Conclusion
- 5.0 Summary
- 6.0 Tutor Marked Assignment
- 7.0 References

1.0 INTRODUCTION

We discussed what the subject Decision Analysis is all about we defined a decision, decision maker, business decision analysis and threw light on various components involved in Business Decision Analysis. In this unit, we shall proceed to explaining the different approaches used in analysing a decision problem. Two key approaches present themselves – Qualitative Approach, and the Quantitative Approach. These two broad approaches form the core of business decision analysis. They will be broken down into several specific methods that will be discussed throughout in this course of study.

2.0 OBJECTIVES

After studying this unit, you should be able to:

- Identify the qualitative and quantitative approaches to decision analysis.
- Identify the qualitative and quantitative tools of analysis.
- Use the Expected monetary value (EMV) and Expected opportunity (EOL) techniques in solving decision problems.
- Solve decision problems using the different criteria available.

2.0 MAIN CONTENT

3.1 MAIN APPROACHES TO DECISION ANALYSIS

As identified earlier, the two main approaches to decision analysis are the *qualitative and quantitative* approaches.

3.1.1 QUALITATIVE APPROACH TO DECISION MAKING

Qualitative approaches to decision analysis are techniques that use human judgement and experience to turn qualitative information into quantitative estimates (Lucey 1988) as quoted by Dixon – Ogbechi (2001). He identified the following qualitative decision techniques

- (1) Delphi Method
- (2) Market Research
- (3) Historical Analogy

According to Akingbade (1995), qualitative models are often all that are feasible to use in circumstances, and such models can provide a great deal of insight and enhance the quality of decisions that can be made. Quantitative models inform the decision maker about relationships among kinds of things. Knowledge of such relationships can inform the decision maker about areas to concentrate upon so as to yield desired results.

Akingbade (1995) presented the following examples of qualitative models:

- (1) Influence diagrams.
 - (2) Cognitive maps.
 - (3) Black box models.
 - (4) Venn Diagrams.
 - (5) Decision trees.
 - (6) Flow charts etc.
- (Dixon – Ogbechi 2001)

Let us now consider the different qualitative approaches to decision making.

Delphi Method: The Delphi method is technique that is designed to obtain expert consensus for a particular forecast without the problem of submitting to pressure to conform to a majority view. It is used for long term forecasting. Under this method, a panel is made to independently answer a sequence of questionnaire which is used to produce the next questionnaire. As a result, any information available to a group of experts is passed on to all, so that subsequent judgements are refined as more information and experience become available (Lucey 1988).

Market Research: These are widely used procedures involving opinion surveys; analysis of market data, questionnaires designed to gage the reaction of the market to a particular product, design, price, etc. It is often very accurate for a relatively short term.

Historical Analogy: Historical Analogy is used where past data on a particular item are not available. In such cases, data on similar subjects are analysed to establish the life cycle and expected sales of the new product. This technique is useful in forming a board impression in the medium to long term. (Lucey (1988) as quoted by Dixon-Ogbechi (2001)).

3.1.2 QUANTITATIVE APPROACH

This technique or approach lends itself to the careful measurement of operational requirements and returns. This makes the task of comparing one alternative with another very much more objective. Quantitative technique as argued by Dixon-Ogbechi (2001), embraces all the operational techniques that lend themselves to quantitative measurement. Harper (1975) presents the following quantitative techniques.

- (a) **Mathematics:** Skemp (1971) defined Mathematics as “a system of abstraction, classification and logical reasoning. Generally, Mathematics can be subdivided into two
- i. Pure Mathematics
 - ii. Applied Mathematics

Pure Mathematics is absolutely abstract in not concerning itself with anything concrete but purely with structures and logical applications, implications and consequences of such structures.

Applied Mathematics is the application of proved abstract generalization (from pure Mathematics) to the physical world (Akingbade, 1996) both pure and applied Mathematics can be broken into the following subdivisions.

- (1) Arithmetic
- (2) Geometry
- (3) Calculus
- (4) Algebra
- (5) Trigonometry
- (6) Statistics

- (b) **Probability:** Probability is widely used in analysing business decisions, Akingbade (1996) defined probability as a theory concerned with the study of processes involving uncertainty. Lucey (1988) defined probability as “the quantification of uncertainty”. Uncertainty may be expressed as likelihood, chance or risk.

- (c) **Mathematical Models:** According to Dixon-Ogbechi (2001), A Mathematical model is a simplified representation of a real life situation in Mathematical terms. A Mathematical model is Mathematical idealization in the form of a system proposition, formula or equation of a physical, biological or social phenomenon (Encarta Premium, 2009).

- (d) **Statistics:** Statistics has been described as a branch of Mathematics that deals with the collection, organization, and analysis of numerical data and with such problems as experiment design and decision making (Microsoft Encarta Premium, 2009).

3.2 OBJECTIVE OF DECISION MAKING

Before a decision maker embarks on the process of decision making he/she must set clear objectives as to what is expected to be achieved at the end of the process. In Business decision analysis; there are two broad objectives that decision makers can possible set to achieve. These are:

- Maximization of profit, and
- Minimization of Loss

Most decisions in business fall under these two broad categories of objectives. The decision criterion to adopt will depend on the objective one is trying to achieve.

In order to achieve profit maximization, the Expected Monetary Value (EMV) approach is most appropriate. As will be seen later, the Expected Value of the decision alternative is the sum of highlighted pay offs for the decision alternative, with the weight representing the probability of occurrence of the states of nature. This approach is possible when there are probabilities attached to each state of nature or event. The EMV approach to decision making is assumed to be used by the *optimistic* decision maker who expects to maximize profit from his investment. The technique most suitable for minimization of loss is the Expected opportunity loss (EOL) approach. It is used in the situation where the decision maker expects to make a loss from an investment and tries to keep the loss as minimum as possible. This type of problem is known as minimization problem and the decision maker here is known to be *pessimistic*. The problem under the EMV approach is known as a maximization problem as the decision maker seeks to make the most profit from the investment. These two approaches will be illustrated in details in the next section.

3.3 STEPS IN DECISION THEORY APPROACH

Decision theory approach generally involves four steps. Gupta and Hira (2012) present the following four steps.

Step 1: List all the viable alternatives

The first action the decision maker must take is to list all viable alternatives that can be considered in the decision. Let us assume that the decision maker has three alternative courses of action available to him a, b, c.

Step 2: Identify the expected future event

The second step is for the decision maker to identify and list all future occurrences. Often, it is possible for the decision maker to identify the future states of nature; the difficulty is to identify which one will occur. Recall, that these future states of nature or occurrences are not under the control of the decision maker. Let us assume that the decision maker has identified four of these states of nature: i, ii, iii, iv.

Step 3: Construct a payoff table

After the alternatives and the states of nature have been identified, the next task is for the decision maker to construct a payoff table for each possible combination of alternative courses of action and states of nature. The payoff table can also be called contingency table.

Step 4: Select optimum decision criterion

Finally, the decision maker will choose a criterion which will result in the largest payoff or which will maximize his wellbeing or meet his objective. An example of pay off table is presented below.

Contingency table 1

Alternative	States of nature			
	i	ii	iii	iv
a	a_i	a_{ii}	a_{iii}	a_{iv}
b	b_i	b_{ii}	b_{iii}	b_{iv}
c	c_i	c_{ii}	c_{iii}	c_{iv}

Fig2.1: An example of the payoff table.

As we can see from the payoff table above, a,b,c are the alternative strategies, i, ii, iii, iv are the states of nature. Therefore the decision maker has identified four states of nature and three alternative strategies. Apart from the alternative strategy column and the row representing the states of nature, other cells in the table are known as condition outcomes. They are the outcomes resulting from combining a particular strategy with a state of nature. Therefore we can say that the contingency table shows the different outcomes when the states of nature are combined with the alternatives.

3.4 DECISION MAKING CRITERIA

There are five criteria with which a decision maker can choose among alternatives given different states of nature. Gupta and Hira (2012) are of the view that choice of a criterion is determined by the company's policy and attitude of the decision maker. They are:

- (1) Maximax Criterion or Criterion of Optimism
- (2) Maximin Criterion or Criterion of Pessimism (Wald Criterion)
- (3) Minimax Regret Criterion (Savage Criterion)
- (4) Laplace Criterion or Equally likely criterion or criterion of Rationality (Bayes' Criterion)
- (5) Hurwicz Criterion or Criterion of Realism

Now let us see how we can solve problems using the above criteria.

Example 2.1: Consider the contingency matrix given below

Fig2.2: Pay-off table.

Contingency table 2

Alternative Products	Market Demand		
	High (₦)	Moderate (₦)	Low (₦)
Body Cream	500	250	-75
Hair Cream	700	300	-60
Hand Lotion	400	200	-50

The matrix above shows the payoffs of an investor who has the choice either investing in the production of Body Cream, or Hair cream, or hand lotion. Whichever of the three products he decides to produce; he will encounter three types of market demand. It may turn out that the market demand for any of the product is high, or moderate or low. In other words, the production of body cream, or hair cream, or hand lotion represent the alternative courses of action or strategies available to the investor, while the occurrence of either high demand, or moderate demand, or low demand represent the states of nature for which the investor has no control over. Now, how would the investor arrive at the choice of product to manufacture? We are going to analyse the decision problem using the five criteria earlier listed below.

3.4.1 MAXIMAX CRITERION (CRITERION OF OPTIMISM)

The maximax criterion is an optimistic criterion. Here, the decision maker aims to maximize profit or his outcome. It involves an optimistic view of future outcomes. This is done by selecting the largest among maximum payoffs. However, the disadvantage of this criterion is that it does not make use of all available information in getting the quantitative values. This is not often the case on real life situations. The criterion has also been criticised for being too optimistic and assumes that the future will always be rosy.(Adebayo et al, 2006).

Fig2.3: Pay-off table.

Alternative Products	Market Demand			Max Column (₦)	Maxi max (₦)
	High (₦)	(₦) Moderate	Low (₦)		
Body Cream	500	250	-75	500	
Hair Cream	700	300	-60	700	700
Hand Lotion	400	200	-50	400	

Let us now try to solve the decision problem in the matrix above using the maximax criterion.

Step 1: Create an additional column to the right hand side of the matrix and call it max column as shown below.

Step 2: Identify the **maximum** pay-off in each alternative course of action (i.e. Either the role for Body Cream, or Hair Cream, or Hand Lotion) and place it in the corresponding cell on the maximum column.

Step 3: Identify and select the pay-off with the highest value on the maximum column. This value becomes your optimal value using the maximax criterion.

Step 4: Make recommendations.

As we can see from Contingency table 3 above, the maximax value is ₦700.

Recommendation: Using the maximax decision criterion, the decision maker should manufacture hair cream to maximize worth ₦700.

3.4.2 MAXIMIN CRITERION (CRITERION OF PESSIMISM)

Under the maximin Criterion, the decision maker is assumed to be pessimistic. The objective here is to maximize the minimum possible outcome. It is a decision situation where the decision maker tries to make the most of bad situations and avoids taking risks and incurring huge losses. According to Adebayor et al (2006), the weakness of this criterion is that the result may not always be unique. It has also been criticized for being an unduly careful. However, it has the advantage of helping one to be in the best possible condition in case the worst happens.

In analysing a decision situation using this criterion, we use the following steps.

Step 1: Create an additional column to the right hand side of your pay-off matrix- minimum column.

Step 2: Select the **minimum** pay-off from each alternative and place on the corresponding cell in the minimum column.

Step 3: Identify and select the maximum pay-off in the minimum column

Step 4: Make recommendation

Using data in contingency matrix 2

Minimum Col (₦)	Maximin (₦)
- 75	
- 60	
- 50	- 50

Fig.Fig2.4: Payoff table- Minimum and Maximum Columns.

Recommendation: Using the maximin decision criterion, the decision maker should manufacture hand lotion with a pay-off of - ₦50.

3.4.3 MINIMAX REGRET CRITERION (SAVAGE CRITERION)

This decision criterion was developed by L.J. Savage. He pointed out that the decision maker might experience regret after the decision has been made and the states of nature i.e. events have occurred. Thus the decision maker should attempt to minimize regret before actually selecting a particular alternative (strategy) (Gupta and Hira, 2011). The criterion is aimed at minimizing opportunity loss.

The following steps are used to solve problems using this criterion.

Step 1: For each column, identify the highest payoff

Step 2: Subtract the value from itself every other pay-off in the column to obtain the regret matrix.

Step 3: Create an additional column to the right of your regret matrix and call it maximum column.

Step 4: Identify and select the maximum value from each alternative strategy

Step 5: Find the minimum value in the maximum column created.

Step 6: Make recommendations.

Fig.2.5: Payoff table.

Example 2.2

Contingency table 4

Alternative Products	Market Demand		
	High (₦)	Moderate (₦)	Low (₦)
Body Cream	500	250	-75
Hair Cream	700	300	-60
Hand Lotion	400	200	-50



Fig.2.6: Regret matrix.

Regret matrix 1

Alternative Products	Market Demand			Max Column	Mini max
	High (₦)	Moderate (₦)	Low (₦)		
Body Cream	200	50	25	200	
Hair Cream	0	0	10	10	10
Hand Lotion	300	100	0	300	

Recommendation: Using the minimax regrets criterion, the decision maker should manufacture hair cream to minimize loss worth ₦10.

3.4.4 EQUALLY LIKELY OF LAPLACE CRITERION (BAYES' OR CRITERION OF RATIONALITY)

This criterion is based upon what is known as the principle of insufficient reasons. Since the probabilities associated with the occurrence of various events are unknown, there is not enough information to conclude that these probabilities will be different. This criterion assigns equal probabilities to all the events of each alternative decision and selects the alternative associated with the maximum expected payoff. Symbolically, if “n” denotes the number of events and “s” denotes the pay-offs, then expected value for strategy, say s_i is

$$1/N[P_1 + P_2 + \dots + P_n]$$

or simply put

$$\frac{P_1 + P_2 + \dots + P_n}{n}$$

The steps to follow are:

Step 1: Compute the average for each alternative using the above formula.

Step 2: Select the maximum outcome from the calculation in step 1 above

Step 3: Make recommendations

Example 2.3

Contingency table 5

Alternative Products	Market Demand			Average Column	Max Col.
	High (₦)	Moderate (₦)	Low (₦)		
Body Cream	500	250	-75	$\frac{500 + 250 + 75 = 675}{3} = 225$	
Hair Cream	700	300	-60	$\frac{700 + 300 - 60 = 940}{3} = 313.3$	313.3
Hand Lotion	400	200	-50	$\frac{400 + 200 - 50 = 550}{3} = 183.3$	

Fig. 2.7: Payoff table.

Recommendation: Using the equally likely criterion, the decision should manufacture Hair Cream worth ₦313.3

3.4.5 HURWICZ CRITERION (CRITERION OF REALISM)

This criterion is also called weighted average criterion. It is a compromise between the maximax (optimistic) and maximin (Pessimistic) decision criteria. This concept allows the decision maker to take into account both maximum and minimum for each alternative and assign them weights according to his degree of optimism or pessimism. The alternative which maximises the sum of these weighted pay-offs is then selected. (Gupta and Hira, 2012)

The Hurwicz Criterion Comprises the following steps:

Step 1: Choose an appropriate degree of optimism α (α lies between zero and one ($0 < \alpha < 1$)), so that $(1-\alpha)$ represents the degree of pessimism. α is called coefficient or index of optimism.

Step 2: Determine the maximum as well as minimum value of each alternative course of action.

Step 3: Determine the criterion of realism using the following formula

$$CR_i = \alpha (\text{Max in Row}_i) + (1 - \alpha) (\text{Min in Row}_i)$$

Step 4: Select the maximum outcome in step 3 above

Step 5: Make Recommendation

Example 2.4

EXAMPLE: Using the contingency table 3 above,

Maximum	Min in Row
500	-75
700	-60
400	-50

Fig. 2.8: Max. And Min. Rows.

For alternative Body Cream (b)

$$(R_b = \alpha (\text{Maxim Row}_b) + (1 - \alpha) (\text{min in Row}_b))$$

Let us assume $\alpha = 0.5$

$$\begin{aligned} CR_{bc} &= 0.5 (500) + (1 - 0.5) (-75) \\ &= 0.5 (500) + 0.5 (-75) \\ &= 250 - 37.5 = \mathbf{212.5} \end{aligned}$$

For alternative Hair Cream

$$\begin{aligned} CR_{hc} &= 0.5 (700) + (0.5) (-60) \\ &= 350 + (-30) \\ &= 350 - 30 = \mathbf{320} \end{aligned}$$

For alternative Hand Lotion

$$\begin{aligned} CR_{hl} &= 0.5 (400) + (0.5) (-50) \\ &= 200 - 25 = 177 \end{aligned}$$

Therefore

$$CR_{bc} = \mathbf{212.5}$$

$$CR_{hc} = \mathbf{320}$$

$$CR_{hl} = 177$$

Recommendation: Using the Hurwicz Criterion, the decision maker should manufacture Hair Cream worth $\mathbf{320}$.

We have seen how interesting and simple it is to use the five criteria in analysing decision problems. However, the above analysis can only be used under a situation of uncertainty

where the decision maker neither knows the future states of nature nor have the probability of occurrence of the states of nature. This will be discussed in greater detail in the next unit.

4.0 CONCLUSION

An individual or a small group of people faced with simple decision may apply common sense in solving their problems. However, this is not the case with big corporate organizations which are faced with very complex decision problems. An application of common sense in such complex situations will not be appropriate as it will lead mostly to wrong decisions. Complex decision problems demand the use of specialized tools and techniques for analysis of problem and eventual arrival at the best alternative.

5.0 SUMMARY

This unit outlines briefly some approaches to decision analysis. It identifies two basic approaches to decision analysis: Qualitative and Quantitative approaches. The Qualitative approach includes: Delphi Method, Market Research and Historical Analogy. The Quantitative technique includes the use of Mathematics, Probability, Mathematical models and statistics to analyse decision problems. Finally, we discuss the five criteria for solving problems under the condition of uncertainty: maximax, maximin, laplace's, minimax regret, and Hurwicz criterion.

6.0 TUTOR MARKET ASSIGNMENT

- (1) Differential between qualitative and quantitative techniques.
- (2) List and explain four qualitative techniques of decision analysis.
- (3) What do your understanding by a state of Nature?
- (4) Differentials between the Expected monetary value (EMV) and the Expected opportunity Loss (EOL) techniques.
- (5) Consider the payoff matrix below and analyse the decision problem completely.

Contingency table 6

Alternatives	State of nature		
	S ₁	S ₂	S ₃
d ₁	15,000	35,000	200
d ₂	75,000	15,000	-100
d ₃	20,000	45,000	-1,000

Hint: Whenever you are asked to analyse a problem completely, it means you should use the five criteria early discussed for analyse the decision problem.

7.0 REFERENCE

- Adebayo, O.A. et al (2006). Operations Research in Decision and Production Management.
- Akingbade, F. (1995). Practical Operational Research for Developing Countries: A Process Framework approach, Lagos: Panaf Publishing Inc.
- Dixon – Ogbechi, B.N. (2001). Decision Theory in Business, Lagos: Philglad Nig. Ltd.
- Gupta, P.K and Hira, D.S. (2012). Operations Research, New – Delhi: S. Chand & Company.
- Harper, W.M. (1975). Operational Research, London: Macdonald & Evans Ltd.
- Lucey, T. (1988). Quantitative Techniques: An Instructional Manual, London: DP Publications.

UNIT 7: TYPES OF DECISION SITUATIONS

- 1.0 Introduction
- 2.0 Objectives
- 3.0 Main Content
 - 3.1 Elements of Decision Situation
 - 3.2 Types of Decision Situations
 - 3.2.1 Decision Making Under Condition of Certainty
 - 3.2.2 Decision Making Under Conditions of Uncertainty
 - 3.2.3 Decision Making Under Conditions of Risk
 - 3.2.4 Decision Under Conflict
- 4.0 Conclusion
- 5.0 Summary
- 6.0 Tutor Marked Assignment
- 7.0 References

1.0 INTRODUCTION

Recall that in the previous unit we presented five decision criteria – Maximax, Maximin, Laplace's, Minimax Regret, and Hurwicz criterion. We also stated that the criteria are used for analysing decision situations under uncertainty. In this unit, we shall delve fully into considering these situations and learn how we can use different techniques in analysing problems in certain decision situations i.e Certainty, Uncertainty, Risk, and Conflict situations.

2.0 OBJECTIVES

After studying this unit, you should be able to

- Identify the four conditions under which decisions can be made
- Describe each decision situation
- Identify the techniques for making decision under each decision situation
- Solve problems under each of the decision situation

3.0 MAIN CONTENT

3.1 ELEMENTS OF DECISION SITUATION

Dixon – Ogbechi (2001) presents the following elements of Decision Situation:

- 1 The Decision Maker: The person or group of persons making the decision.
- 2 Value System: This is the particular preference structure of the decision maker.
- 3 Environmental Factors: These are also called states of nature. They can be
 - i. Political
 - ii. Legal
 - iii. Economic factors
 - iv. Social factors
 - v. Cultural factors
 - vi. Technological factors
 - viii. Natural Disasters

- 4 Alternative: There are various decision options available to the decision maker.
- 5 Choice: The decision made.
- 6 Evaluation Criteria: These are the techniques used to evaluate the situation at hand.

3.2 TYPES OF DECISION SITUATIONS

According to Gupta and Hira (2012), there are four types of environments under which decisions can be made. These differ according to degree of certainty. The degree of certainty may vary from complete certainty to complete uncertainty.

3.2.1 DECISION MAKING UNDER CONDITION OF CERTAINTY

In this environment, only one state of nature exists for each alternative. Under this decision situation, the decision maker has complete and accurate information about future outcomes. In other words, the decision maker knows with certainty the consequence of every alternative course of action.

3.2.2 DECISION MAKING UNDER CONDITIONS OF UNCERTAINTY

Here, more than one state of nature exists, but the decision maker lacks sufficient knowledge to allow him assign probabilities to the various state of nature. However, the decision maker knows the states of nature that may possibly occur but does not have information which will enable him to determine which of these states will actually occur. Techniques that can be used to analyse problem under this condition include the Maximax criterion, equally likely or Laplace's criterion, and Hurwicz criterion or Criterion of Realism. These techniques have earlier been discussed. We shall consider a more difficult problem for further illustration.

EXAMPLE3.1- Word Problem

A farmer is considering his activity in the next farming season. He has a choice of three crops to select from for the next planting season – Groundnuts, Maize, and Wheat. Whatever is his choice of crop; there are four weather conditions that could prevail: heaving rain, moderate rain, light rain, and no rain. In the event that the farmer plants Ground nuts and there is heavy rain, he expects to earn a proceed of ₦650,000 at the end of the farming season, if there is moderate rain ₦1,000,000, high rain – ₦450,000 and if there is no rain – (-₦1,000)If the farmer plants Maize, the following will be his proceeds after the harvest considering the weather condition: heavy rain – ₦1,200,000, moderate rain – ₦1,500,000, Light rain – ₦600,000 and no rain ₦2000. And if the farmer decides to plant wheat, he expects to make the following: heavy rain – ₦1,150,000, moderate rain – ₦1,300,000, Light rain- ₦800,000 and No rain – ₦200 -000.

The farmer has contact you, an expert in OR to help him decide on what to do.

Question: Construct a payoff matrix for the above situation, analyse completely and advise the farmer on the course of action to adopt. Assume $\alpha = 0.6$.

Solution

First, construct a contingency matrix from the above problem.

Contingency Matrix 1a

Alternative Crops	Weather conditions			
	Heavy Rain (S ₁) ₦	Moderate Rain (S ₂) ₦	Light Rain (S ₃) ₦	No Rain (S ₄) ₦
Groundnut (d ₁)	750,000	1,000,000	450,000	-1,000
Maize (d ₂)	1,200,000	1,500,000	600,000	2000
Wheat (d ₃)	1,150,000	1,300,000	800,000	-200,000

Fig. 3.1a: Pay- off Table

Contingency Matrix 1b

Alternative Crops	Weather conditions				Max col	Min Col
	S ₁ (₦'000)	S ₂ (₦'000)	S ₃ (₦'000)	S ₄ (₦'000)		
d ₁	750	1,000	450	-1	1,000	-1
d ₂	1,200	1,500	600	2	1,500	2
d ₃	1,150	1,300	800	-200	1,300	-200

Fig. 3.1b: Pay- off Table

Regret Matrix 1

Alternative Crops	Weather conditions				Max col	Min Col
	S ₁ (₦'000)	S ₂ (₦'000)	S ₃ (₦'000)	(S ₄) (₦'000)		
d ₁	1200 – 750 450	1500- 1000 500	800-450 350	2-(1) 3	500	
d ₂	1200 – 1200 0	1500- 1500 0	800-600 200	2-2 0	200	200
d ₃	1200-1150 50	1500- 1300 200	800-800 0	2-(-200) 202	202	
Col max	1200	1500	800	2		

Fig. 3.2: Regret Matrix 1

2. Maximax Criterion

Alt.	Max Col.
d ₁	1,000
d ₂	1,500
d ₃	1,300

Recommendation: Using the maximax criterion, the farmer should select alternative d₂ and plant maize worth ₦1,500,000.

3. Maximin criterion

Alt.	Min. Col.
d ₁	-1
d ₂	2
d ₃	-200

Recommendation: Using the maximum criterion, the farmer should select alternative d₂ and plant maize worth ₦2, 000.

3. Minimax Regret Criterion

Choice of crops	Weather conditions				Max Col	Min Col
	S ₁	S ₂	S ₃	(S ₄)		
d ₁	450	500	350	3	500	
d ₂	0	0	200	0	200	200
d ₃	50	200	0	202	202	

Fig. 3.3: Pay-off Table

Recommendation: Using the Mini Max Regret Criterion, the decision maker should select alternative d₂ and plant maize to minimize loss worth ₦200,000

4. Laplace Criterion

$$d_1 = \frac{750 + 1000 + 450 - 1}{4} = 549.75$$

$$d_2 = \frac{1200 + 1500 + 600 + 2}{4} = \underline{\underline{825.50}}$$

$$d_3 = \frac{1150 + 1300 + 800 - 200}{4} = 762.50$$

Recommendation: Using the Equally Likely or Savage Criterion, the farmer should select alternative d₂ to plant maize worth ₦825,500.

(5) Hurwicz Criterion

$$\alpha = 0.6, 1 - \alpha = 0.4$$

$$CR_i = (\max \text{ in row}) + (1 - \alpha) (\min \text{ in row})$$

$$CR_1 = 0.6 (1000) + (0.4) (-1) = 600 + (-0.4) = 599.6$$

$$CR_2 = 0.6 (1500) + (0.4) (2) = 900 + 0.8 = \underline{\underline{900.8}}$$

$$CR_3 = 0.6 (1300) + (0.4) (-200) = 780 + (-80) = 700$$

Recommendation: Using the Hurwicz criterion the farmer should select alternative d₂ and cultivate maize worth ₦900, 800.00.

3.2.3 DECISION MAKING UNDER CONDITIONS OF RISK

Under the risk situation, the decision maker has sufficient information to allow him assign probabilities to the various states of nature. In other words, although the decision maker does not know with certainty the exact state of nature that will occur, he knows the probability of occurrence of each state of nature. Here also, more than one state of nature exists. Most Business decisions are made under conditions of risk. The probabilities assigned to each state of nature are obtained from past records or simply from the

subjective judgement of the decision maker. A number of decision criteria are available to the decision maker. These include.

- (i) Expected monetary value criterion (EMV)
 - (ii) Expected Opportunity Loss Criterion (EOL)
 - (iii) Expected Value of Perfect Information (EVPI)
- (Gupta and Hira, 2012)

We shall consider only the first two (EMV and EOL) criteria in details in this course.

i. EXPECTED MONETARY VALUE (EMV) CRITERION

To apply the concept of expected value as a decision making criterion, the decision maker must first estimate the probability of occurrence of each state of nature. Once the estimations have been made, the expected value of each decision alternative can be computed. The expected monetary value is computed by multiplying each outcome (of a decision) by the corresponding probability of its occurrence and then summing the products. The expected value of a random variable is written symbolically as E(x), is computed as follows:

$$E(x) = \sum_{k=0}^n x_i P(x_i)$$

(Taylor III, 2007)

EXAMPLE 3.2

A businessman has constructed the payoff matrix below. Using the EMV criterion, analyse the situation and advise the businessman on the kind of property to invest on.

Contingency Matrix 2

Decision to invest	State of Nature		
	Good Economic Conditions (₹)	Poor Economic Condition (₹)	Turbulent Economic Condition (₹)
Apartment building (d ₁)	50,000	30,000	15,000
Office building (d ₂)	100,000	40,000	10,000
Warehouse (d ₃)	30,000	10,000	-20,000
Probabilities	0.5	0.3	0.2

Fig. 3.4: Pay-off Table. Adapted from Taylor, B.W. III (2007)

Introduction to Management Science, New Jersey: Pearson Education Inc.

SOLUTION

$$\begin{aligned}
 EVd_1 &= 50,000 (0.5) + 30,000 (0.3) + 15,000 (0.2) \\
 &= 25,000 + 9,000 + 3,000 \\
 &= ₹37,000
 \end{aligned}$$

$$\begin{aligned}
 \text{EVd}_2 &= 100,000 (0.5) + 40,000 (0.3) + 10,000 (0.2) \\
 &= \cancel{50,000} + 12,000 + 2000 \\
 &= \underline{\underline{\text{N}64,000}}
 \end{aligned}$$

$$\begin{aligned}
 \text{EVd}_3 &= 30,000 (0.5) + 10,000 (0.3) + (-20,000)(0.2) \\
 &= 15,000 + 3000 - 4000 \\
 &= \text{N}14,000
 \end{aligned}$$

Recommendation: Using the EMV criterion, the businessman should select alternative d_2 and invest in office building worth $\text{N}64,000$.

Under this method, the best decision is the one with the greatest expected value. From the above EXAMPLE, the alternative with the greatest expected value is EVd_1 which has a monetary value of $\text{N}37,000$. This does not mean that $\text{N}37,000$ will result if the investor purchases apartment buildings, rather, it is assumed that one of the payoffs values will result in $\text{N}25,000$ or $\text{N}9,000$ or $\text{N} 3,000$. The expected value therefore implies that if this decision situation occurs a large number of times, an average payoff of $\text{N}37,000$ would result, Alternatively, if the payoffs were in terms of costs, the best decision would be the one with the lowest expected value.

ii. EXPECTED OPPORTUNITY LOSS (EOL)

The expected opportunity Loss criterion is a regret criterion. It is used mostly in minimization problems. The minimization problem involves the decision maker either trying to minimize loss or minimize costs. It is similar the Minimax Regret Criterion earlier discussed. The difference however, is that it has probabilities attached to each state of nature or occurrence.

The difference in computation between the EMV and EOL methods is that, unlike the EMV methods, a regret matrix has to be constructed from the original matrix before the EOL can be determined.

EXAMPLE 3.3

We shall determine the best alternative EOL using contingency matrix 2 above
First, we construct a regret matrix from contingency matrix 2 above. Remember how the Regret matrix table is constructed? Ok. Let us do that again here.

Quick Reminder

To construct a regret matrix, determine the highest value in each state of nature and subtract every payoff in the same state of nature from it. You will observe that most of the payoff will become negative values and zero.

Regret Matrix 2

Decision to invest	State of Nature		
	(₦)	(₦)	(₦)
Apartment building (d ₁)	(100,000 - 50,000) 50,000	(40,000 - 30,000) 10,000	(15,000 - 15,000) 0
Office building (d ₂)	(100,000 - 100,000) 0	(40,000 - 40,000) 0	(15,000 - 10,000) 5,000
Warehouse (d ₃)	(100,000 - 30,000) 70,000	(40,000 - 40,000) 30,000	(15,000+20,000) 35,000
Probabilities	0.5	0.3	0.2

Fig. 3.3: Regret Matrix 2

$$\begin{aligned}
 EOLd_1 &= 50,000 (0.5) + 10,000 (0.3) + 0(0.2) \\
 &= 25,000 + 3,000 + 0 \\
 &= \underline{\underline{₦28,000}}
 \end{aligned}$$

$$\begin{aligned}
 EOLd_2 &= 0(0.5) + 0(0.3) + 5,000 (0.2) \\
 &= 0 + 0 + 1,000 \\
 &= \underline{\underline{₦1,000}}
 \end{aligned}$$

$$\begin{aligned}
 EOLd_3 &= 70,000 (0.5) + 30,000 (0.3) + 35,000 (0.2) \\
 &= 35,000 + 9,000 + 7,000 \\
 &= \underline{\underline{₦51,000}}
 \end{aligned}$$

Recommendation: Using the EOL criterion, the decision maker should select alternative d₂ and invest in office building worth ₦1, 000.

The Optimum investment option is the one which minimizes expected opportunity losses, the action calls for investment in office building at which point the minimum expected loss will be ₦1, 000.

You will notice that the decision rule under this criterion is the same with that of the Minimax Regret criterion. This is because both methods have the same objectives that is, the minimization of loss. They are both pessimistic in nature. However, loss minimization is not the only form minimization problem. Minimisation problems could also be in the form of minimisation of cost of production or investment. In analysing a problem involving the cost of production you do not have to construct a regret matrix because the pay-off in the table already represents cost.

NOTE: It should be pointed out that EMV and EOL decision criteria are completely consistent and yield the same optimal decision alternative.

iii EXPECTED VALUE OF PERFECT INFORMATION

Taylor III (2007) is of the view that it is often possible to purchase additional information regarding future events and thus make better decisions. For instance, a farmer could hire a weather forecaster to analyse the weather conditions more accurately to determine which weather condition will prevail during the next farming season. However, it would not be wise for the farmer to pay more for this information than he stands to gain in extra yield from having this information. That is, the information has some maximum yield value that represents the limit of what the decision maker would be willing to spend. This value of information can be computed as an expected value – hence its name, expected value of perfect information (EVPI).

The expected value of perfect information therefore is the maximum amount a decision maker would pay for additional information. In the view of Adebayo et al (2007), the value of perfect information is the amount by which the profit will be increased with additional information. It is the difference between expected value of optimum quantity under risk and the expected value under certainty. Using the EOL criterion, the value of expected loss will be the value of the perfect information.

Expected value of perfect information can be computed as follows

$$EVPI = EV_{wPI} - EMV_{max}$$

Where

EVPI = Expected value of perfect information

EV_wPI = Expected value with perfect information

EMV_{max} = Maximum expected monetary value or Expected value without perfect information

(Or minimum EOL for a minimization problem)

EXAMPLE 3.4

Using the data on payoff matrix 3 above,

Decision to invest	State of Nature		
	Good (N)	Poor (N)	Turbulent (N)
Apartment building (d ₁)	50,000	30,000	15,000
Office building (d ₂)	100,000	40,000	10,000
Warehouse (d ₃)	30,000	10,000	-20,000
Probabilities	0.5	0.3	0.2

Fig. 3.3: Pay-off Tale

$$EV_{wPI} = \sum P_j \times \text{best out on each state of nature } (S_j).$$

The expected value with perfect information can be obtained by multiplying the best outcome in each state of nature by the corresponding probabilities and summing the results.

We can obtain the EVwPI from the table above as follows.

$$\begin{aligned} \text{EVwPI} &= 100,000 \times 0.5 + 40,000 \times 0.3 + 15,000 \times 0.2 \\ &= 50,000 + 12,000 + 3,000 \\ &= \mathbf{N65,000} \end{aligned}$$

Recall that our optimum strategy as calculated earlier was $\mathbf{N64,000}$.

$$\begin{aligned} \text{EVP1} &= \text{EVwPI} - \text{EMV}_{\max} \\ &= \mathbf{N65000} - 64,000 \\ &= \mathbf{N1,000} \end{aligned}$$

The expected value of perfect information (EVPI) is $\mathbf{N1000}$. This implies that the maximum amount the investor can pay for extra information is $\mathbf{N1000}$. Because it is difficult to obtain perfect information, and most times unobtainable, the decision maker would be willing to pay some amount less than $\mathbf{N1000}$ depending on how accurate the decision maker believes the information is. Notice that the expected value of perfect information ($\mathbf{N1000}$) equals our expected opportunity loss (EOL) of $\mathbf{N1000}$ as calculated earlier.

Taylor III (2007) provides a justification for this. According to him, this will always be the case, and logically so, because regret reflects the difference between the best decision under a state of nature and the decision actually made. This is the same thing determined by the expected value of perfect information.

3.2.4 DECISION UNDER CONFLICT

Decision taken under conflict is a competitive decision situation. This environment occurs when two or more people are engaged in a competition in which the action taken by one person is dependent on the action taken by others in the competition. In a typical competitive situation the player in the competition evolve strategies to outwit one another. This could be by way intense advertising and other promotional efforts, location of business, new product development, market research, recruitment of experienced executives and so on. An appropriate techniques to use in solving problems involving conflicts is the Game Theory (Adebayo et al 2007).

Practice Exercise

- (1) Identify and discuss the situations under which decision are made.
- (2) An investor is confronted with a decision problem as represented in the matrix below. Analyse the problem Using the EMV and EOL criteria and advise the decision maker on the best strategy to adopt.

State of Nature	Alternatives			Prob.
	Expand	Construct	Subcontract	
High (₦)	50,000	70,000	30,000	0.5
Moderate (₦)	25,000	30,000	15,000	0.3
Low (₦)	25,000	-40,000	-1,000	0.15
Nil (₦)	-45,000	-80,000	-10,000	0.05

Hint: Note that the positions of the states of nature and the alternative strategies have changed.

4.0 CONCLUSION

It is important for decision makers to always identify the situations they are faced with and fashion out the best technique for analysing the situation in order to arrive at the best possible alternative course of action to adopt.

5.0 SUMMARY

In this unit, we have discussed the different situations under which a decision maker is faced with decision problems. These decision situations include Certainty, Uncertainty, Risk and Conflict situation. Decision situations could also be referred to as decision environments. We have also identified and discussed various techniques used in solving problems under these situations. The deterministic approach to decision analysis which includes simple arithmetic techniques for simple problems and cost-volume analysis, linear programming, transportation model, assignment models queuing models etc. for complex problems could be used to solve problems under situation of certainty.

6.0 TUTOR MARKED ASSIGNMENT

- (1) Who is a decision maker?
- (2) List and explain four situations under which decisions can be made.
- (3) Identify the techniques that can be used to analyse decision problems under the following situations
 - (i) Certainty
 - (ii) Uncertainty
 - (iii) Risk
 - (iv) Conflict
- (4) Consider the contingency matrix below

Alternatives	States of Nature		
	S ₁ (₦)	S ₂ (₦)	S ₃ (₦)
A ₁	100,000	75,000	1000
A ₂	625,000	12,000	920
A ₃	11,900	750	-73

Analyse the situation completely and advise the decision maker on the optimal strategy to adopt under each criterion.

7.0 REFERENCES

Adebayo, O.A. et al (2006). Operations Research in Decision and Production Management.

Dixon – Ogbechi, B.N. (2001). Decision Theory in Business, Lagos: Philglad Nig. Ltd.

Gupta, P.K., and Hira, D.S. (2012). Operations Research, New – Delhi: S. Chand & Company.

Taylor III, B.W. (2007). Introduction to Management Science, 9th Edition. New Jersey: Pearson Education Inc.

UNIT 4: DECISION TREES

- 1.0 Introduction
- 2.0 Objectives
- 3.0 Main Content
 - 3.1 Definition
 - 3.2 Benefits of using decision tree
 - 3.3 Disadvantage of the decision tree
 - 3.4 Components of the decision tree
 - 3.5 Structure of a decision tree
 - 3.6 How to analyse a decision tree
 - 3.7 The Secretary Problem
 - 3.7.1 Advantages of the Secretary Problem over the General Decision tree
 - 3.7.2 Analysis of the Secretary Problem
- 4.0 Conclusion
- 5.0 Summary
- 6.0 Tutor Marked Assignment
- 7.0 References

1.0 INTRODUCTION

So far, we have been discussing the techniques used for decision analysis. We have demonstrated how to solve decision problems by presenting them in a tabular form. However, if decision problems can be presented on a table, we can also represent the problem graphically in what is known as a decision tree. Also the decision problems discussed so far dealt with only single stage decision problem.

2.0 OBJECTIVES

After studying this unit, you should be able to

- Describe a decision tree
- Describe what Decision nodes and outcome nodes are
- Represent problems in a decision trees and perform the fold back and tracing forward analysis
- Calculate the outcome values using the backward pass
- Identify the optimal decision strategy

3.0 MAIN CONTENT

3.1 DEFINITION

A decision tree is a graphical representation of the decision process indicating decision alternatives, states of nature, probabilities attached to the states of nature and conditional benefits and losses (Gupta & Hira 2012). A decision tree is a pictorial method of showing a sequence of inter-related decisions and outcomes. All the possible choices are shown on

the tree as branches and the possible outcomes as subsidiary branches. In summary, a decision tree shows: the decision points, the outcomes (usually dependent on probabilities and the outcomes values) (Lucey, 2001).

3.2 BENEFITS OF USING DECISION TREE

Dixon-Ogbechi (2001) presents the following advantages of using the decision tree

- They assist in the clarification of complex decisions making situations that involve risk.
- Decision trees help in the quantification of situations.
- Better basis for rational decision making are provided by decision trees.
- They simplify the decision making process.

3.3 DISADVANTAGE OF THE DECISION TREE

- The disadvantage of the decision tree is that it becomes time consuming, cumbersome and difficult to use/draw when decision options/states of nature are many.

3.4 COMPONENTS OF THE DECISION TREE

It is important to note the following components of the structure of a decision problem

- **The choice or Decision Node:** Basically, decision trees begin with choice or decision nodes. The decision nodes are depicted by square (\square). It is a point in the decision tree where decisions would have to be made. Decision nodes are immediately by alternative courses of action in what can be referred to as the decision fork. The decision fork is depicted by a square with arrows or lines emanating from the right side of the square ($\square \leftarrow$). The number of lines emanating from the box depend on the number of alternatives available.
- **Chance Node:** The chance node can also be referred to as state of nature node or event node. Each node describes a situation in which an element of uncertainty is resolved. Each way in this uncertainty can be resolved is represented by an arc that leads rightward from its chance node, either to another node or to an end-point. The probability on each such arc is a conditional probability, the condition being that one is at the chance node to its left. These conditional probabilities sum to 1 (One), as they do in probability tree (Denardo, 2002).

The state of nature or chance nodes are depicted by circles (\bigcirc), it implies that at this point, the decision maker will have to compute the expected monetary value (EMV) of each state of nature. Again the chance event node is depicted this ($\bigcirc \leftarrow$)

3.5 STRUCTURE OF A DECISION TREE

The structure and the typical components of a decision tree are shown in the diagram below.

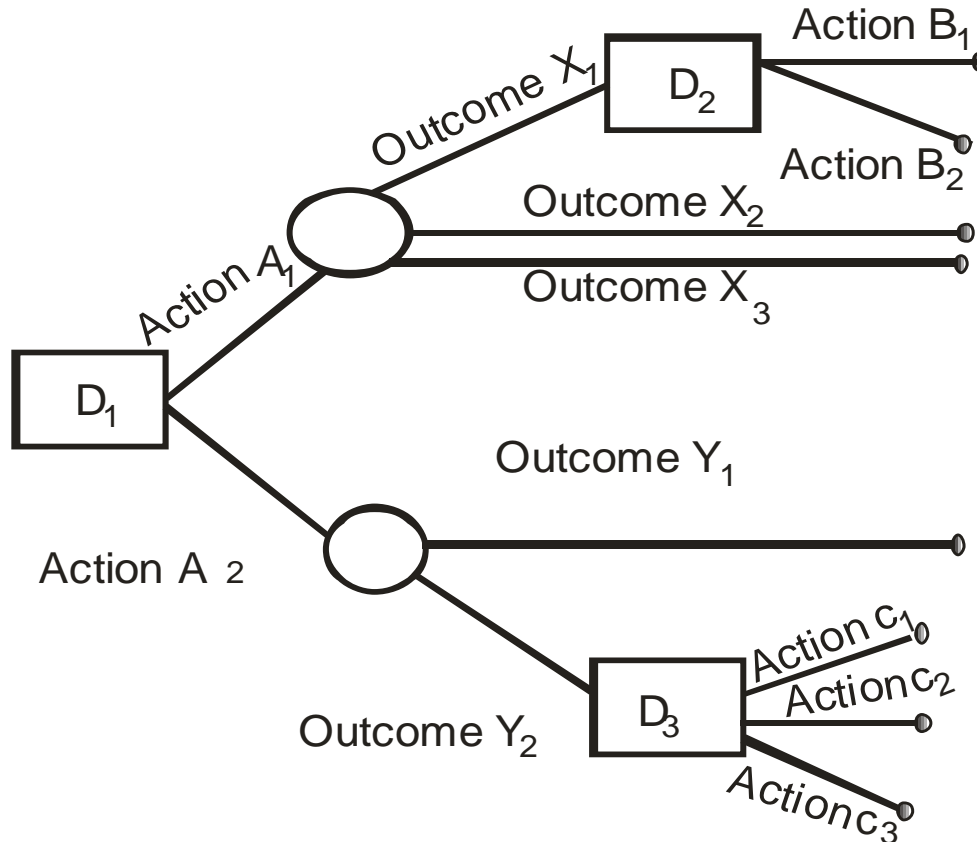

Fig.13: Adapted from Lucey, T (2001), Quantitative Techniques, 5th London: Continuum

The above is a typical construction of a decision tree. The decision tree begins with a decision node D_1 signifying that the decision maker is first of all presented with a decision to make. Immediately after the decision node, there are two courses of Action A_1 and A_2 . If the decision maker chooses A_1 , there are three possible outcomes – X_1 , X_2 , X_3 . And if chooses A_2 , there will be two possible outcomes Y_1 and Y_2 and so on.

3.6 HOW TO ANALYSE A DECISION TREE

The decision tree is a graphical representation of a decision problem. It is multi-state in nature. As a result, a sequence of decisions are made repeatedly over a period of time and such decisions depend on previous decisions and may lead to a set of probabilistic outcomes. The decision tree analysis process is a form of probabilistic dynamic programming (Dixon-Ogbechi, 2001).

Analysing a decision tree involves two states

- i. **Backward Pass:** This involves the following steps
 - starting from the right hand side of the decision tree, identify the nearest terminal. If it is a chance event, calculate the EMV (Expected Monetary Value). And it is a decision node, select the alternative that satisfies your objective.
 - Repeat the same operation in each of the terminals until you get to the end of the left hand side of the decision tree.
- ii. **Forward Pass:** The forward pass analysis involves the following operation.
 - Start from the beginning of the tree at the right hand side, at each point, select the alternative with the largest value in the case of a minimization problem or profit payoff, and the least payoff in the case of a minimization problem or cost payoff.
 - Trace forward the optimal contingency strategy by drawing another tree only with the desired strategy.

These steps are illustrate below

EXAMPLE 4.1

Contingency Matrix 1

States of Nature	Alternatives		Probability
	Stock Rice (A ₁)	Stock Maize (A ₂)	
High demand (S ₁) (₹)	8,000	12,000	0.6
Low demand (S ₂) (₹)	4,000	-3,000	0.4

Fig. 4.1: Pay-off Matrix

Question: Represent the above payoff matrix on a decision tree and find the optimum contingency strategy.

We can represent the above problem on a decision tree thus:

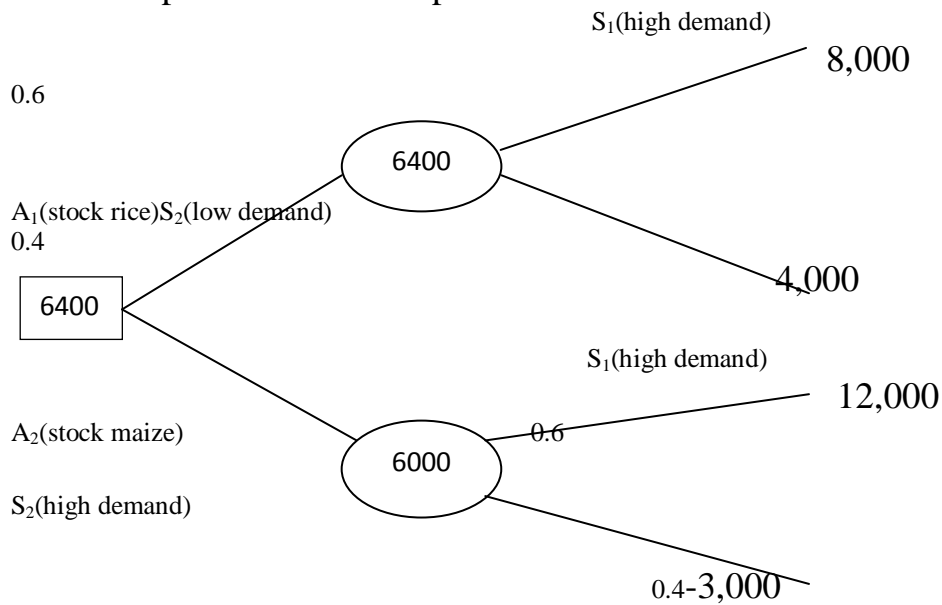

Fig. 4.2: A Decision Tree.

Next, we compute the EMV for alternatives A₁ and A₂.

$$\begin{aligned} EMV_{A_1} &= 8,000 \times 0.6 + 4,000 \times 0.4 = 6400 \\ &= 4800 + 1600 \end{aligned}$$

$$\begin{aligned} EMV_{A_2} &= 12,000 \times 0.6 + (-3,000) \times 0.4 \\ &= 7,200 - 1,200 = \underline{6,000} \end{aligned}$$

EMV_{A₁} gives the highest payoff

We can now draw our optimal contingency strategy thus:

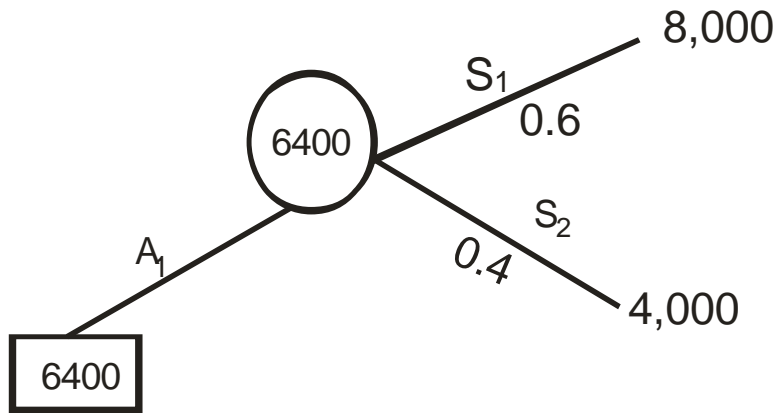

Fig. 4.3: Optimal Contingency Strategy

The above decision tree problem is in its simplest form. They also could be word problem to be represented on a decision tree diagram unlike the above problem that has already been put in tabular form. Let us try one of such problems.

EXAMPLE 4.2

A client has contracted NOUNCIL, a real estate firm to help him sell three properties A,B,C that he owns in Banana Island. The client has agreed to pay NOUNCIL 5% commission on each sale. The agent has specified the following conditions: NOUNCIL must sell property A first, and this he must do within 60days. If and when A is sold, NOUNCIL receives 5% commission on the sale, NOUNCIL can then decide to back out on further sale or go ahead and try to sell the remaining two property B and C within 60 days. If they do not succeed in selling the property within 60days, the contract is terminated at this stage. The following table summarises the prices, selling Costs (incurred by NOUNCIL whenever a sale is made) and the probabilities of making sales

Property	Prices of property	Selling Cost	Probability
A	12,000	400	0.7
B	25,000	225	0.6
C	50,000	450	0.5

Fig. 4.3: Pay-off Matrix

- (i) Draw an appropriate decision tree representing the problem for NOUNCIL.
- (ii) What is NOUNCIL’s best strategy under the EMV approach?

(Question Adapted from Gupta and Hira (2012))

SOLUTION

Hint: Note that the probabilities provided in the table are probabilities of sale. Therefore, to get the probability of no sale, we subtract the prob. of sale from 1

Prob. of no Sales = 1 – prob. of sales

NOUNCIL gets 5% Commission if they sell the properties and satisfy the specified conditions.

The amount they will receive as commission on sale of property A,B, and C are as follows

$$\text{Commission on A} = 5/100 \times 12,000 = \text{N}6000$$

$$\text{Commission on B} = 5/100 \times 25,000 = \text{N}1250$$

$$\text{Commission on C} = 5/100 \times 50,000 = \text{N}2500$$

The commission calculated above are conditional profits to NOUNCIL. To obtain the actual profit accrued to NOUNCIL from the sale of the properties, we subtract the selling cost given in the table above from the commission.

NOUNCIL'S Actual profit

$$A = \text{N}6000 - \text{N}4000 = \text{N}2000$$

$$B = \text{N}1250 - \text{N}225 = \text{N}1025$$

$$C = \text{N}2500 - \text{N}450 = \text{N}2050$$

We now construct our decision tree

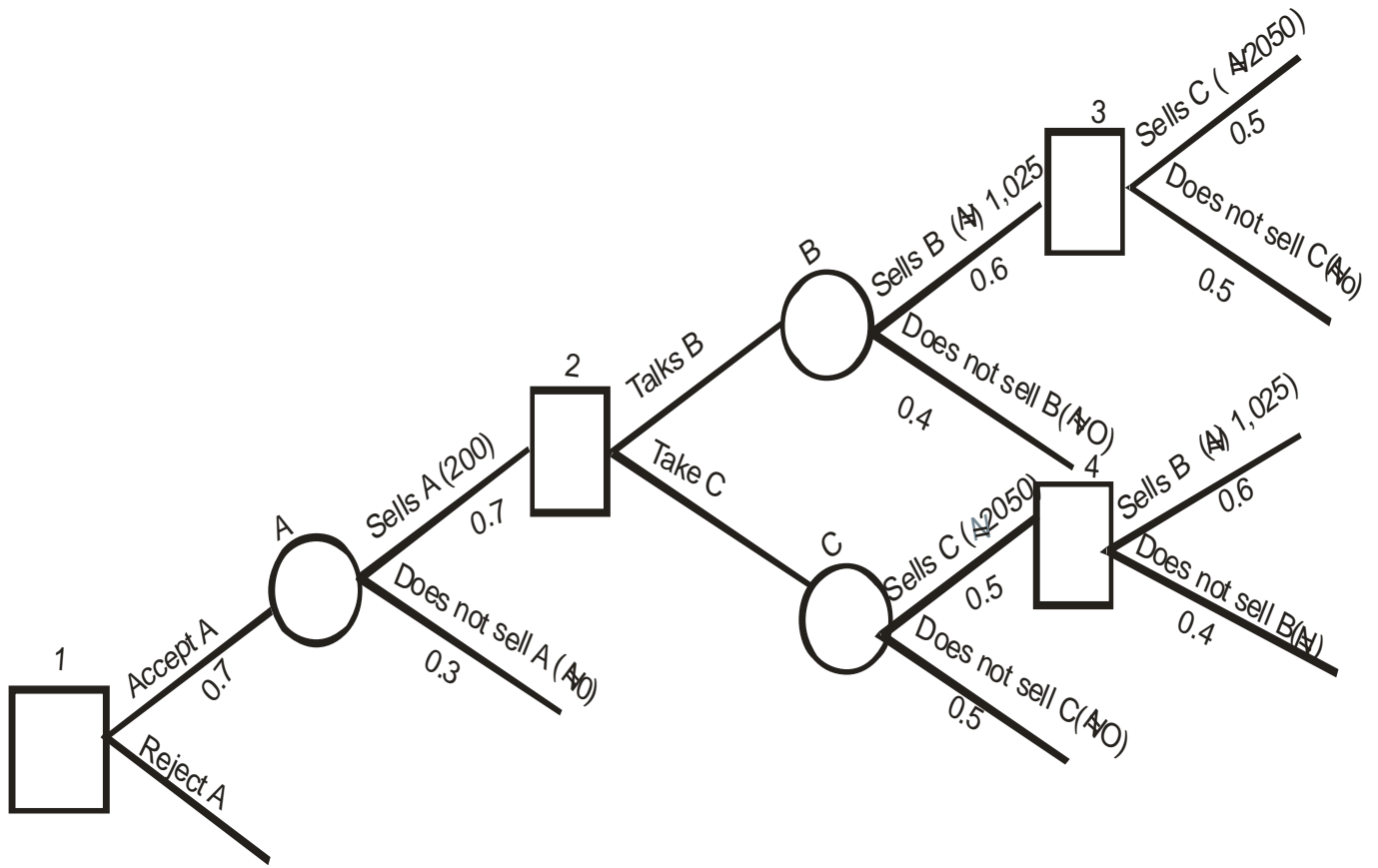

Fig. 4.4: A Decision Tree

BACKWARD PASS ANALYSIS

EMV of Node 3 = ~~N~~ (0.5 2050 + 0.5 x 0) = ~~N~~1025

EMV of Node 4 = ~~N~~ (0.6 x 1,025 + 0.4 x 0) = ~~N~~615

EMV of Node B = [0.6 (1025 + 1025) + 0.4 x 0] = 1230

Note: 0.6 (EMV of node 3 + profit from sales of B at node B)

EMV of Node C = [0.5 (2050 + 615) + 0.5 x 0] = ~~N~~1332.50

Note: same as EMV of B above

EMV of Node 2 = ~~N~~1332.50 (Higher EMV at B and C)

EMV of Node A = ~~N~~[0.7 (200 + 1,332.50) + 0.3 x 0] = ~~N~~1072.75

EMV of Node 1 = ~~N~~1072.75

Optimal contingency strategy

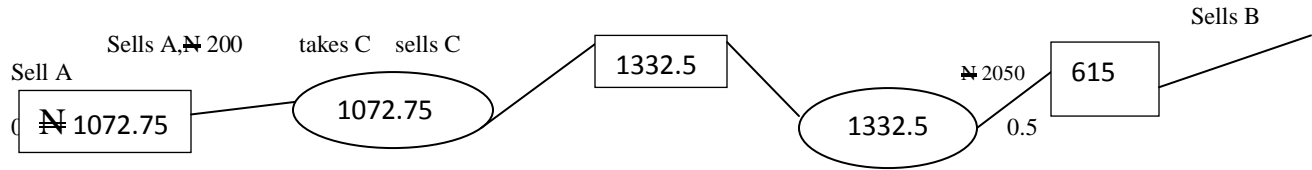

Fig. 4.4b: Optimal Contingency Strategy

The optimal contingency strategy path is revealed above. Thus the optimum strategy for NOUNCIL is to sell A, if they sell A, then try sell C and if they sell C, then try sell B to get an optimum expected amount of ₦1072.75.

Let us try another example as adapted from Dixon – Ogbechi (2001).

3.7 THE SECRETARY PROBLEM

The secretary problem was developed to analyse decision problems that are complex and repetitive in nature. This type of decision tree is a modification upon general decision tree in that it collapses the branches of the general tree and once an option is jettisoned, it cannot be recalled.

3.7.1 Advantages of the Secretary Problem Over the General Decision Tree

In addition to the advantages of the general decision tree the secretary problem has the following added advantages

- (1) It is easy to draw and analyse.
- (2) It saves time.

3.7.2 Analysis of the Secretary Problem

The analysis of a secretary decision tree problem is similar to that of the general decision tree. The only difference is that since the multi stage decision problem could be cumbersome to formulate when the branches become too many, the secretary problem collapses the different states of nature into one. This will be demonstrated in the example below.

4.0 CONCLUSION

Decision trees provide a graphical method of presenting decision problems. The problems are represented in a form of a tree diagram with the probabilities and payoffs properly labelled for easier understanding, interpretation, and analysis. Once a decision problem can be represented in tabular form, it can also be presented in form of a decision tree.

However, the general decision tree could become complex and cumbersome to understand and analysed if the nature of the problem is also complex and involves a large number of options. The secretary formulation method of the general decision tree was developed as an improvement upon the general formulation to be used for analysing complex and cumbersome decision problems. Generally, the decision tree provides a simple and straight forward way of analysing decision problems.

5.0 SUMMARY

Now let us cast our minds back to what we have learnt so far in this unit. We learnt that the decision tree is mostly used for analysing a multi-stage decision problem. That is, when there is a sequence of decisions to be made with each decision having influence on the next. A decision tree is a pictorial method of showing a sequence of inter-related decisions and outcomes. It is a graphical representation that outlines the different states of nature, alternatives courses of actions with their corresponding probabilities. The branches of a decision tree are made up of the decision nodes at which point a decision is to be made, and the chance node at which point the EMV is to be computed.

6.0 TUTOR MARKED ASSIGNMENT

- 1 What do you understand by the term decision tree?
- 2 Identify the two formulations of the decision tree and give the difference between them.
- 3 Outline the advantages and disadvantage of a decision tree.
- 4 Write short notes on the following:
 - i Decision Node
 - ii Chance Even Node
- 5 Identify and discuss the two method of analysis of a decision tree

7.0 REFERENCES

- Dixon – Ogbechi, B.N. (2001). Decision Theory in Business, Lagos: Philglad Nig. Ltd.
- Denardo, E.V. (2002). The Schience of Decision making: A Problem-Based Approach Using Excel. New York: John Wiley.
- Gupta, P.K., and Hira, D.S. (2012). Operations Research, New – Delhi: S. Chand & Company.

MODULE THREE

UNIT 1 OPERATIONS RESEARCH (OR)

- 1.0 Introduction
- 2.0 Objectives
- 3.0 Main Content
 - 3.1 Development of Operations Research
 - 3.2 Definition of Operations Research
 - 3.3 Characteristics of OR
 - 3.4 Scientific Method In Operations Research
 - 3.4.1 The Judgement Phase
 - 3.4.2 The Research Phase
 - 3.4.3 The Action Phase
 - 3.5 Necessity of Operations Research in Industry
 - 3.6 Scope of Operations Research
 - 3.7 Scope of Operations Research in Financial Management
- 4.0 Conclusion
- 5.0 Summary
- 6.0 Tutor Marked Assignment
- 7.0 References

1.0 INTRODUCTION

We mentioned in Unit 1, module 1, that the subject Business Decision Analysis takes its root from the discipline Operations Research or Operational Research (OR). This unit is devoted to giving us background knowledge of OR. It is however, not going to be by any way exhaustive as substantial literature been developed about quantitative approaches to decision making. The root of this literature are centuries old, but much of it emerged only during the past half century in tandem with the digital computer (Denardo, 2002). The above assertion relates only to the development of the digital computer for use in solving OR problems.

2.0 OBJECTIVES

At the end of this study unit, you should be able to:

- Briefly trace the development of OR.
- Define OR.
- Outline the characteristics of OR.
- Give reasons why operations research is necessary in industries.

3.0 MAIN CONTENT

3.1 DEVELOPMENT OF OPERATIONS RESEARCH

Gupta and Hira (2012) traced the development of Operations Research (OR) thus:

i THE PERIOD BEFORE WORLD WAR II

The roots of OR are as old as science and society. Though the roots of OR extend to even early 1800s, it was in 1885 when Ferderick, W. Taylor emphasized the application of scientific analysis to methods of production, that the real start took place. Taylor conducted experiments in connection with a simple shovel. His aim was to find that weight load of Ore moved by shovel would result in the maximum amount of ore move with minimum fatigue. After many experiments with varying weights, he obtained the optimum weight load, which though much lighter than that commonly used, provided maximum movement of ore during a day. For a “first-class man” the proper load turned out to be 20 pounds. Since the density of Ore differs greatly, a shovel was designed for each density of Ore so as to assume the proper weight when the shovel was correctly filled. Productivity rose substantially after this change.

Henry L. Gantt, also of the scientific management era, developed job sequencing and scheduling methods by mapping out each job from machine to machine, in order to minimize delay. Now, with the Gantt procedure, it is possible to plan machine loading months in advance and still quote delivery dates accurately.

However, the first industrial Revolution was the main contributing factor towards the development of OR. Before this period, most of the industries were small scale, employing only a handful of men. The advent of machine tools – the replacement of man by machine as a source of power and improved means of transportation and communication resulted in fast flourishing industries. It became increasingly difficult for a single man to perform all the managerial functions (Planning, sales, purchasing production, etc). Consequently, a division of management functions took place. Managers of production marketing, finance, personal, research and development etc. began to appear. For example, production department was sub-divided into sections like maintenance, quality control, procurement, production planning etc.

ii WORLD WAR II

During War II, the military management in England called on a team of scientists to study the strategic and tactical problems of air and land defence. This team was under the leadership of Professor P. M. S. Blackett of University of Manchester and a former Naval Officer. “Blackett’s circus”, as the group was called, included three Physiologists, two Mathematical Physicists, one Astrophysicist, one Army officer, one Surveyor, one general physicist and two Mathematicians. The objective of this team was to find out the most effective allocation of limited military resources to the various military operations and to activities within each operation. The application included effective use of newly

invented radar, allocation of British Air Force Planes to missions and the determination best patterns for searching submarines. This group of scientists formed the first OR team..

iii **POST WORLD WAR II**

Immediately after the war, the success of military teams attracted the attention of industrial managers who were seeking solutions to their problems. Industrial operations research in U.K and USA developed along different lines, and in UK the critical economic efficiency and creation of new markets. Nationalisation of new key industries further increased the potential field for OR. Consequently OR soon spread from military to government, industrial, social and economic planning.

In the USA, the situation was different impressed by its dramatic success in UK, defence operations research in USA was increased. Most of the war-experienced OR workers remained in the military services. Industrial executives did not call for much help because they were returning to peace and many of them believed that it was merely a new application of an old technique. Operations research has been known by a variety of names in that country such as Operational Analysis, Operations Evaluation, Systems Analysis, Systems Evaluation, Systems Research, Decision Analysis, Quantitative Analysis, Decision Science, and Management Science.

3.2 DEFINITION OF OPERATIONS RESEARCH

Many definitions of OR have been suggested by writers and experts in the field of operations Research. We shall consider a few of them.

1 Operations Research is the applications of scientific methods by inter disciplinary teams to problems involving the control of organized (Man-Machine) Systems so as to provide solutions which best serve the purpose of the organization as a whole (Ackoff & Sasieni, 1991).

2 Operations Research is applied decision theory. It uses any scientific, Mathematical or Logical means to attempt to cope with the problems that confront the executive when he tries to achieve a thorough going rationality in dealing with his decision problems (Miller and Starr, 1973).

3 Operations research is a scientific approach to problem solving for executive management (Wagner, 1973).

4 Operations Research is the art of giving bad answers to problems, to which, otherwise, worse answers are given (Saaty, 1959).

3.3 CHARACTERISTICS OF OR

Ihemeje (2002) presents four vital characteristics of OR.

1 The OR approach is to develop a scientific model of the system under investigation with which to compare the probable outcomes of alternative management decision or strategies.

2 OR is essentially an aid to decision making. The result of an operation study should have a direct effect on managerial action, management decision based on the finding of an OR model are likely to be more scientific and better informed.

3 It is based on the scientific method. It involves the use of carefully constructed models based on some measurable variables. It is, in essence, a quantitative and logical approach rather than a qualitative one. The dominant techniques of OR are mathematical and statistical.

Other characteristics of OR are:

- 4 It is system (Executive) Oriented
- 5 It makes use of interdisciplinary teams
- 6 Application of scientific method
- 7 Uncovering of new problems
- 8 Improvement in quality of decision

3.4 SCIENTIFIC METHOD IN OPERATIONS RESEARCH

Of these three phases, the research phase is the longest. The other two phases are equally important as they provide the basis of the research phase. We now consider each phase briefly as presented by Gupta & Hira (2012).

3.4.1 THE JUDGEMENT PHASE

The judgement phases of the scientific method of OR consists of the following:

A Determination of the Operation: An operation is the combination of different actions dealing with resources (e.g men and machines) which form a structure from which an action with regards to broader objectives is maintained. For example an act of assembling an engine is an operation.

B Determination of Objectives and Values Associated with the operation: In the judgement phase, due care must be given to define correctly the frame of references of operations. Efforts should be made to find the type of situation, e.g manufacturing, engineering, tactical, strategic etc.

C Determination of Effectiveness Measures: The measure of effectiveness implies the measure of success of a model in representing a problem and providing a solution. It is the connecting link between the objectives and the analysis required for corrective action.

3.4.2 THE RESEARCH PHASE

The research phase of OR includes the following:

- a. **Observation and Data Collection:** This enhances better understanding of the problem.
- b. **Formulation of Relevant Hypothesis:** Tentative explanations, when formulated as propositions are called hypothesis. The formulation of a good hypothesis depends upon the sound knowledge of the subject–matter. A hypothesis must provide an answer to the problem in question.
- c. **Analysis of Available Information and Verification of Hypothesis:** Quantitative as well as qualitative methods may be used to analyse available data.
- d. **Prediction and Generalisation of Results and Consideration of Alternative Methods:** Once a model has been verified, a theory is developed from the model to obtain a complete description of the problem. This is done by studying the effect of changes in the parameters of the model. The theory so developed may be used to extrapolate into the future.

3.4.3 THE ACTION PHASE

The action phase consists of making recommendations for remedial action to those who first posed the problem and who control the operations directly. These recommendations consists of a clear statement of the assumptions made, scope and limitations of the information presented about the situation, alternative courses of action, effects of each alternative as well as the preferred course of action.

A primary function of OR group is to provide an administrator with better understanding of the implications of the decisions he makes. The scientific method supplements his ideas and experiences and helps him to attain his goals fully.

3.5 NECESSITY OF OPERATIONS RESEARCH IN INDUSTRY

Having studied the scientific methods of operations research, we now focus on why OR is important or necessary in industries. OR came into existence in connection with war operations, to decide the strategy by which enemies could be harmed to the maximum possible extent with the help of the available equipment. War situations required reliable decision making. But the need for reliable decision techniques is also needed by industries for the following reasons.

- **Complexity:** Today, industrial undertakings have become large and complex. This is because the scope of operations has increased. Many factors interact with each other in a complex way. There is therefore a great uncertainty about the outcome of interaction of factors like technological, environmental, competitive etc. For

instance, a factory production schedule will take the following factors into account:

- i Customer demand.
- ii Raw material requirement.
- iii Equipment Capacity and possibility of equipment failure.
- iv Restrictions on manufacturing processes.

It could be seen that, it is not easy to prepare a schedule which is both economical and realistic. This needs mathematical models, which in addition to optimization, help to analyse the complex situation. With such models, complex problems can be split into simpler parts, each part can be analysed separately and then the results can be synthesized to give insights into the problem.

- **Scattered Responsibility and Authority:** In a big industry, responsibility and authority of decision-making is scattered throughout the organization and thus the organization, if it is not conscious, may be following inconsistent goals. Mathematical quantification of OR overcomes this difficulty to a great extent.
- **Uncertainty:** There is a lot of uncertainty about economic growth. This makes each decision costlier and time consuming. OR is essential from the point of view of reliability.

3.6 SCOPE OF OPERATIONS RESEARCH

We now turn our attention towards learning about the areas that OR covers. OR as a discipline is very broad and is relevant in the following areas.

- **In Industry:** OR is relevant in the field of industrial management where there is a chain of problems or decisions starting from the purchase of raw materials to the dispatch of finished goods. The management is interested in having an overall view of the method of optimizing profits. In order to take scientific decisions, an OR team will have to consider various alternative methods of producing the goods and the returns in each case. OR should point out the possible changes in overall structure like installation of a new machine, introduction of more automation etc.

Also, OR has been successfully applied in production, blending, product mix, inventory control, demand forecast, sales and purchases, transportation, repair and maintenance, scheduling and sequencing, planning, product control, etc.

- **In Defence:** OR has wide application in defence operations. In modern warfare, the defence operations are carried out by a number of different agencies, namely – Air force, Army, and Navy. The activities performed by each of these agencies can further be divided into sub-activities viz: operations, intelligence, administration,

training, etc. There is thus a need to coordinate the various activities involved in order to arrive at an optimum strategy and to achieve consistent goals.

- **In Management:** Operations Research is a problem-solving and decision-making science. It is a tool kit for scientific and programmable rules providing the management a qualitative basis for decision making regarding the operations under its control. Some of the area of management where OR techniques have been successfully applied are as follows:

A Allocation and Distribution

- i Optimal allocation of limited resources such as men, machines, materials, time, and money.
- ii Location and size of warehouses, distribution centres retail depots etc
- iii Distribution policy

B Production and Facility Planning

- i Selection, location and design of production plants, distribution centre and retail outlets.
- ii Project scheduling and allocation of resources.
- iii Preparation of forecast for the various inventory items and computing economic order quantities and reorder levels.
- iv Determination of number and size of the items to be produced.

C Procurement

- i What, how, and when to purchase at minimum purchase cost.
- ii Bidding and replacement policies.
- iii Transportation planning and vendor analysis.

D Marketing

- i Product selection, timing, and competitive actions.
- ii Selection of advertisement media.
- iii Demand forecast and stock levels.

E Finance

- i Capital requirement, cash-flow analysis.
- ii Credit policy, credit risks etc.
- iii Profit plan for the organisation.

F Personnel

- i Selection of personnel, determination of retirement age and skills.
- ii Recruitment policies and assignment of jobs.
- iii Wages/salaries administration.

G Research and Development

- i Determination of areas for research and development.
- ii Reliability and control of development projects.
- iii Selection of projects and preparation of budgets.

3.7 SCOPE OF OPERATIONS RESEARCH IN FINANCIAL MANAGEMENT

The scope of OR in financial management covers the following areas

- i Cash Management:** Linear programming techniques are helpful in determining the allocation of funds to each section.
- ii Inventory Control:** Inventory control techniques of OR can help management to develop better inventory policies and bring down the investment in inventories. These techniques help to achieve optimum balance between inventory carrying costs and shortage cost.
- iii Simulation Technique:** Simulation considers various factors that affect and present and projected cost of borrowing money from commercial banks, and tax rates etc. and provides an optimum combination of finance (debt, equity, retained earnings) for the desired amount of capital.
- iv Capital Budgeting**
It involves evaluation of various investment proposals (viz, market introduction of new products and replacement of equipment with a new one).

4.0 CONCLUSION

In this unit, you have learnt what operations research is all about. You can now go on and apply the knowledge in your work

5.0 SUMMARY

Operations Research (OR) began as an interdisciplinary activity to solve complex military problems during World War II. Utilizing principles from mathematics, engineering, business, computer science, economics, and statistics, OR has developed into a full fledged academic discipline with practical application in business, industry, government and military. Currently regarded as a body of established mathematical models and methods essential to solving complicated management issues, OR provides quantitative analysis of problems from which managers can make objective decisions. Operations Research and Management Science (OR/MS) methodologies continue to flourish in numerous decision making fields.

6.0 TUTOR MARKED ASSIGNMENT

1. Trace the history and development of operations to the founding fathers of the field of management.
2. Give two definitions of operations research with identified authors.
3. Identify the four main characteristics of operations research.
4. Identify and briefly discuss the phases involved in the Scientific Method in Operations research.

7.0 REFERENCES

Ackoff, R., and Sisiemi, M. (1991). Fundamentals of Operations Research, New York: John Wiley and Sons Inc.

Churchman, C.W., Ackoff, R.L., and Arnoff, E.L.(1957). Introduction to Operations Research, New York: John Wiley and Sons Inc.

Denardo, E.V. (2002). The Science of Decision making: A Problem-Based Approach Using Excel. New York: John Wiley.

Gupta, P.K., and Hira, D.S. (2012). Operations Research, New – Delhi: S. Chand & Company.

Ihemeje, J.C. (2002). Fundamentals of Business Decision Analysis, Lagos- Sibon Books

UNIT 2: MODELLING IN OPERATIONS RESEARCH

- 1.0 Introduction
- 2.0 Objectives
- 3.0 Main Content
 - 3.1 Definition
 - 3.2 Classification of Models
 - 3.3 Characteristics of Good models
 - 3.4 Advantages of Models
 - 3.5 Limitations of Models
 - 3.6 model Construction
 - 3.7 Approximation (Simplification) of Models
 - 3.8 Types of mathematical Models
- 4.0 Conclusion
- 5.0 Summary
- 6.0 References
- 7.0 Tutor Marked Assignment

1.0 Introduction

The construction and use of models is at the core of operations research. Operations research is concerned with scientifically deciding how to best design and operate man-machine systems, usually under conditions requiring the allocation of scarce resources. Modelling is a scientific activity that aims to make a particular part or feature of the world easier to understand, define, quantify, visualize, or simulate. Models are typically used when it is either impossible or impractical to create experimental conditions in which scientists can directly measure outcomes. Direct measurement of outcomes under controlled conditions will always be more reliable than modelled estimates of outcomes.

2.0 OBJECTIVES

At the end of this unit, you should be able to

- Define a Model
- Describe modelling
- Give a classification of models
- Outline the advantages and disadvantages of models

3.0 Main Content

3.1 Definition

Scientific modelling is an activity the aim of which is to make a particular part or feature of the world easier to understand, define, quantify, visualize, or simulate. It requires selecting and identifying relevant aspects of a situation in the real world and then using different types of models for different aims, such as conceptual models to better understand, operational models to operationalize, mathematical models to quantify, and

graphical models to visualize the subject ([http://en.wikipedia.org/wiki/Scientific modelling](http://en.wikipedia.org/wiki/Scientific_modelling))

Adebayo et al (2010) define Modelling as a process whereby a complex life problem situation is converted into simple representation of the problem situation. They further described a model as a simplified representation of complex reality. Thus, the basic objective of any model is to use simple inexpensive objects to represent complex and uncertain situations. Models are developed in such a way that they concentrate on exploring the key aspects or properties of the real object and ignore the other objects considered as being insignificant. Models are useful not only in science and technology but also in business decision making by focusing on the key aspects of the business decisions (Adebayo et al, 2010).

3.2 Classification of Models

The following are the various schemes by which models can be classified:

- i. By degree of abstraction
- ii. By function
- iii. By structure
- iv. By nature of the environment

Let us now briefly discuss the above classifications of models as presented by Gupta and Hira (2012)

i. By Degree of Abstraction.

Mathematical models such as Linear Programming formulation of the blending problem, or transportation problem are among the most abstract types of models since they require not only mathematical knowledge, but also great concentration to the real idea of the real-life situation they represent.

Language models such as languages used in cricket or hockey match commentaries are also abstract models.

Concrete models such as models of the earth, dam, building, or plane are the least abstract models since they instantaneously suggest the shape or characteristics of the modelled entity.

ii. By Function

The types of models involved here include

Descriptive models which explain the various operations in non-mathematical language and try to define the functional relationships and interactions between various operations. They simply describe some aspects of the system on the basis of observation, survey, questionnaire, etc. but do not predict its behaviour. Organisational charts, pie charts, and layout plan describe the features of their respective systems.

Predictive models explain or predict the behaviour of the system. Exponential smoothing forecast model, for instance, predict the future demand

Normative or prescriptive models develop decision rules or criteria for optimal solutions. They are applicable to repetitive problems, the solution process of which can be programmed without managerial involvement. Linear programming is also a prescriptive or normative model as it prescribes what the managers must follow.

iii. By Structure

- **Iconic or physical models**

In iconic or physical models, properties of real systems are represented by the properties themselves. Iconic models look like the real objects but could be scaled downward or upward, or could employ change in materials of real object. Thus, iconic models resemble the system they represent but differ in size, they are images. They thus could be full replicas or scaled models like architectural building, model plane, model train, car, etc.

- **Analogue or Schematic Models**

Analogue models can represent dynamic situations and are used more often than iconic models since they are analogous to the characteristics of the system being studied. They use a set of properties which the system under study possesses. They are physical models but unlike iconic models, they may or may not look like the reality of interest. They explain specific few characteristics of an idea and ignore other details of the object. Examples of analogue models are flow diagrams, maps, circuit diagrams, organisational chart etc.

- **Symbolic or mathematical models**

Symbolic models employ a set of mathematical symbols (letters, numbers etc.) to represent the decision variables of the system under study. These variables are related together by mathematical equations/in-equations which describe the properties of the system. A solution from the model is, then, obtained by applying well developed mathematical techniques. The relationship between velocity, acceleration, and distance is an example of a mathematical model. Similarly, cost-volume-profit relationship is a mathematical model used in investment analysis.

iv. By Nature of Environment

- **Deterministic models**

In deterministic models, variables are completely defined and the outcomes are certain. Certainty is the state of nature assumed in these models. They represent completely closed systems and the parameters of the systems have a single value that does not change with time. For any given set of input variables, the same output variables always result. E.O.Q model is deterministic because the effect of changes in batch size on total cost is known. Similarly, linear programming, transportation, and assignment models are deterministic models.

- **Probabilistic Models**

These are the products of the environment of risk and uncertainty. The input and/or output variables take the form of probability distributions. They are semi-closed models and represent the likelihood of occurrence of an event. Thus, they represent to an extent the complexity of the real world and uncertainty prevailing in it. As a example, the exponential smoothing method for forecasting demand a probabilistic model.

3.3 Characteristics of Good Models

The following are characteristics of good models as presented by Gupta and Hira (2012)

1. The number of simplifying assumptions should be as few as possible.
2. The number of relevant variables should be as few as possible. This means the model should be simple yet close to reality.
3. It should assimilate the system environmental changes without change in its framework.

3.4 Advantages of a Model

1. It provides a logical and systematic approach to the problem.
2. It indicates the scope as well as limitation of the problem.
3. It helps in finding avenues for new research and improvement in a system.
4. It makes the overall structure of the problem more comprehensible and helps in dealing with the problem in its entirety.

3.5 Limitations of a Model

1. Models are more idealised representations of reality and should not be regarded as absolute in any case.
2. The reality of a model for a particular situation can be ascertained only by conducting experiments on it.

3.6 Constructing a Model

Formulating a problem requires an analysis of the system under study. This analysis shows the various phases of the system and the way it can be controlled. Problem formulation is the first stage in constructing a model. The next step involves the definition of the measure of effectiveness that is, constructing a model in which the effectiveness of the system is expressed as a function of the variables defining the system. The general Operations Research form is

$$E = f(x_i, y_i),$$

Where

E = effectiveness of the system,

x_i = controllable variables,

y_i = uncontrollable variables but do affect E .

Deriving a solution from such a model consists of determining those values of control variables x_i , for which the measure of effectiveness is measure of effectiveness is

optimised. Optimised includes both maximisation (in case of profit, production capacity, etc.) and minimisation (in case of losses, cost of production, etc.).

The following steps are involved in the construction of a model

1. Selecting components of the system
2. Pertinence of components
3. Combining the components
4. Substituting symbols

3.7 Types of Mathematical Models

The following are the types of mathematical models available:

1. Mathematical techniques
2. Statistical techniques
3. Inventory models
4. Allocation models
5. Sequencing models

4.0 Conclusion

We have seen that models and model construction are very critical in the practice of operations research because they provide the process whereby a complex life problem situation is converted into simple representation of the problem situation. They further described a model as a simplified representation of complex reality. The basic objective of any model is to use simple inexpensive objects to represent complex and uncertain situations. Models are developed in such a way that they concentrate on exploring the key aspects or properties of the real object and ignore the other objects considered as being insignificant. Models

3.0 Summary

This unit introduced us to the concept of models. We have learnt about the importance of models to operations research. The unit opened with a consideration of various definitions of models. Among the definitions is that by Adebayo et al (2010) who defined modelling as a process whereby a complex life problem situation is converted into simple representation of the problem situation. A model as used in Operations Research is defined as an idealised representation of real life situation. It represents one of the few aspects of reality.

6.0 Tutor Marked Assignment

1. Differentiate between model and modelling.
2. List the different classifications of models we have.
3. List and explain the classification of models by structure.
4. Outline five characteristics of a good model.

7.0 REFERENCES

Adebayo, O.A. et al (2006). Operations Research in Decision and Production Management.

Gupta, P.K., and Hira, D.S. (2012). Operations Research, New – Delhi: S. Chand & Company.

Reeb, J., and Leavengood , S. (1998). “*Operations Research, Performance Excellence in the Wood Products Industry*”, October EM 8718

UNIT 3: SIMULATION

- 1.0 Introduction
- 2.0 Objectives
- 3.0 Main Content
 - 3.1 Definition
 - 3.2 Advantages of Simulation Technique
 - 3.3 Application of Simulation
 - 3.4 Limitations of Simulation Technique
 - 3.5 Monte Carlo Simulation
- 4.0 Conclusion
- 5.0 Summary
- 6.0 References
- 7.0 Tutor Marked Assignment

1.0 Introduction

Simulation is primarily concerned with experimentally predicting the behaviour of a real system for the purpose of designing the system or modifying behaviour (Budnick et al., 1988). The main reason for a researcher to resort to simulation is twofold. First of all, simulation is probably the most flexible tool imaginable. Take queuing as an example. While it is very difficult to incorporate renegeing, jumping queues and other types of customer behaviour in the usual analytical models this presents no problem for simulation. A system may have to run for a very long time to reach a steady state. As a result, a modeller may be more interested in transient states, which are easily available in a simulation.

2.0 OBJECTIVES

At the end of this unit, you should be able to

- Define Simulation
- Identify when to use simulation
- Outline the advantages of simulation technique
- Identify the areas of application of simulation

3.0 Main Content

3.1 Definition

According Budnick et al (1988), Simulation is primarily concerned with experimentally predicting the behaviour of a real system for the purpose of designing the system or modifying behaviour. In other words, simulation is a tool that builds a model of a real operation that is to be investigated, and then feeds the system with externally generated data. We generally distinguish between deterministic and stochastic simulation. The

difference is that the data that are fed into the system are either deterministic or stochastic. This chapter will deal only with stochastic simulation, which is sometimes also referred to as Monte Carlo simulation in reference to the Monte Carlo Casinos and the (hopefully) random outcome of their games of chance.

According to Gupta and Hira (2012), simulation is an imitation of reality. “They further stated that simulation is the representation of reality through the use of models or other device which will react in the same manner as reality under given set of conditions. Simulation has also been defined the use of a system model that has the designed characteristics of reality in order to produce the essence of actual operation. According to Donald G. Malcom, a simulated model may be defined as one which depicts the working of a large scale system of men, machine, materials, and information operating over a period of time in a simulated environment of the actual real world condition.

3.2 Advantages of Simulation Technique

When the simulation technique is compared with the mathematical programming and slandered probability analysis, offers a number of advantages over these techniques. Some of the advantages are:

1. Simulation offers solution by allowing experimentation with models of a system without interfering with the real system. Simulation is therefore a bypass for complex mathematical analysis.
2. Through simulation, management can foresee the difficulties and bottlenecks which may come up due to the introduction of new machines, equipment or process. It therefore eliminates the need for costly trial and error method of trying out the new concept on real methods and equipment.
3. Simulation is relatively free from mathematics, and thus, can be easily understood by the operating personnel and non-technical managers. This helps in getting the proposed plan accepted and implemented.

3.3 Application of Simulation

Simulation is quite versatile and commonly applied technique for solving decision problems. It has been applied successfully to a wide range of problems of science and technology as given below:

1. In the field of basic sciences, it has been used to evaluate the area under a curve, to estimate the value of π , in matrix inversion and study of particle diffusion.
2. In industrial problems including shop floor management, design of computer systems, design of queuing systems, inventory control, communication networks, chemical processes, nuclear reactors, and scheduling of production processes.
3. In business and economic problems, including customer behaviour, price determination, economic forecasting, portfolio selection, and capital budgeting.
4. In social problems, including population growth, effect of environment on health and group behaviour.

3.4 Limitations of Simulation Technique

Despite the many advantages of simulation, it might suffer from some deficiencies in large and complex problems. Some of these limitations are given as follows:

- i. Simulation does not produce optimum results when the model deals with uncertainties, the results of simulation only reliable approximations subject to statistical errors.
- ii. Quantification of variables is difficult in a number of situations; it is not possible to quantify all the variables that affect the behaviour of the system.
- iii. In very large and complex problems, the large number of variables and the interrelationship between them make the problem very unwieldy and hard to program.
- iv. Simulation is by no means, a cheap method of analysis.
- v. Simulation has too much tendency to rely on simulation models. This results in application of the technique to some simple problems which can more appropriately be handled by other techniques of mathematical programming.

3.5 Monte Carlo Simulation

The Monte Carlo method of simulation was developed by two mathematicians Jon Von Neumann and Stanislaw Ulam, during World War II, to study how far neurone would travel through different materials. The technique provides an approximate but quite workable solution to the problem. With the remarkable success of this technique on the neutron problem, it soon became popular and found many applications in business and industry, and at present, forms a very important tool of operation researcher's tool kit.

The technique employs random number and is used to solve problems that involve probability and where physical experimentation is impracticable, and formulation of mathematical model is impossible. It is a method of simulation by sampling technique. The following are steps involved in carrying out Monte Carlo simulation.

1. Select the measure of effectiveness (objective function) of the problem. It is either to be minimised or maximised.
2. Identify the variables that affect the measure of effectiveness significantly. For example, a number of service facilities in a queuing problem or demand, lead time and safety stock in inventory problem.
3. Determine the cumulative probability distribution of each variable selected in step 2. Plot these distributions with the values of the variables along the x-axis and cumulative probability values along the y-axis.
4. Get a set of random numbers.

EXAMPLE

Customers arrive at a service facility to get required service. The interval and service times are constant and are 1.8minutes and minutes respectively. Simulate the system for 14minutes. Determine the average waiting time of a customer and the idle time of the service facility.

Solution

The arrival times of customers at the service station within 14 minutes will be:

<i>Customer</i>	:	1	2	3	4	5	6	7	8
<i>Arrival time</i>	:	0	1.8	3.6	5.4	7.2	9.0	10.8	12.6

(minutes)

The time at which the service station begins and ends within time period of 14 minutes is shown below. Waiting time of customers and idle time of service facility are also calculated

<i>Customer</i>	<i>Service</i>		<i>Waiting time of customer</i>	<i>Idle time of service facility</i>
	<i>Begins</i>	<i>ends</i>		
1	0	4	0	0
2	4	8	$4 - 1.8 = 2.2$	0
3	8	12	$8 - 3.6 = 4.4$	0
4	12	16	$12 - 5.4 = 6.6$	0

The waiting time of the first four customers is calculated above. For the remaining, it is calculated below.

<i>Customer</i>	:	5	6	7	8
<i>Waiting time (min)</i>	:	$14 - 7.2 = 6.8$	5.0	3.2	1.4

Therefore, average waiting time of a customer

$$= \frac{0 + 2.2 + 4.4 + 6.6 + 6.8 + 5 + 3.2 + 1.4}{8} = \frac{29.6}{8} = 3.7 \text{ minutes}$$

Idle time of facility = nil.

4.0 CONCLUSION

This unit will assist you to deal with a complex problem solving situation.

You can apply it in investment appraisal, inventory control and evaluating queuing system.

There are soft-wares that will assist you to generate iterations of simulated numbers.

You need to purchase some of them

.

5.0 SUMMARY

This unit provides for us an overview of simulation. It takes us through various conceptualisations on the definition of simulation. Simulation has been defined as the representation of reality through the use of models or other device which will react in the same manner as reality under given set of conditions. A good example of simulation is a children amusement or a cyclical park where children enjoy themselves in a simulated environment like Amusement Parks, Disney Land, Planetarium shows where boats, train rides, etc. are done to simulate actual experience. It is quite versatile and commonly applied technique for solving decision problems such as basic sciences, in industrial problems including shop floor management, in business and economic problems etc.

6.0 Tutor Marked Assignment

1. What do you understand by the term Simulation?
2. Explain six (6) advantages if Simulation.
3. Identify and explain five (5) areas of application of Simulation.
4. Give five limitations of Simulation.

7.0 REFERENCES

- Adebayo, O.A. et al (2006). Operations Research in Decision and Production Management.
- Gupta, P.K., and Hira, D.S. (2012). Operations Research, New – Delhi: S. Chand & Company.
- Jawahar, S. (2006). Overview of System Analysis & Design- Lesson Note no. 1, Ashok Educational Foundation
- Eiselt, H.A., and Sandblom, C. (2012). Operations Research: A Model Based Approach, 2nd ed.,New York: Springer Heidelberg

UNIT 4: SYSTEMS ANALYSIS

- 1.0 Introduction
- 2.0 Objectives
- 3.0 Main content
 - 3.1 Definition
 - 3.2 The Systems Theory
 - 3.3 Elements of a System
 - 3.4 Types of Systems
 - 3.5 Forms of Systems
 - 3.5.1 Conceptual System
 - 3.5.2 Mechanical System
 - 3.5.3 Social System
 - 3.5.4 Deterministic System
 - 3.5.5 Probabilistic System
 - 3.6 The Concept of Entropy in a System
- 4.0 Conclusion
- 5.0 Summary
- 6.0 Tutor Marked Assignment
- 7.0 References

1.0 Introduction

The word system has a long history which can be traced back to Plato (Philebus), Aristotle (Politics) and Euclid (Elements). It had meant "total", "crowd" or "union" in even more ancient times, as it derives from the verb *sunístemi*, uniting, putting together.

"System" means "something to look at". You must have a very high visual gradient to have systematization. In philosophy, before Descartes, there was no "system". Plato had no "system". Aristotle had no "system"(McLuhan. 1967)

In the 19th century the first to develop the concept of a "system" in the natural sciences was the French physicist Nicolas Léonard Sadi Carnot who studied thermodynamics. In 1824 he studied the system which he called the working substance, i.e. typically a body of water vapour, in steam engines, in regards to the system's ability to do work when heat is applied to it. The working substance could be put in contact with either a boiler, a cold reservoir (a stream of cold water), or a piston (to which the working body could do work by pushing on it). In 1850, the German physicist Rudolf Clausius generalized this picture to include the concept of the surroundings and began to use the term "working body" when referring to the system.

2.0 Objectives

After studying this unit, you should be able to

- Define a system
- Identify and describe the types of systems
- Highlight the different forms of systems we have
- Describe how a system is analysed
- Discuss the concept of entropy

3.0 Main content

3.1 Definition

The term system is derived from the Greek word *systema*, which means an organized relationship among functioning units or components. A system exists because it is designed to achieve one or more objectives. We come into daily contact with the transportation system, the telephone system, the accounting system, the production system, and, for over two decades, the computer system. Similarly, we talk of the business system and of the organization as a system consisting of interrelated departments (subsystems) such as production, sales, personnel, and an information system. None of these subsystems is of much use as a single, independent unit. When they are properly coordinated, however, the firm can function effectively and profitably.

There are more than a hundred definitions of the word system, but most seem to have a common thread that suggests that a system is an orderly grouping of interdependent components linked together according to a plan to achieve a specific objective. The word component may refer to physical parts (engines, wings of aircraft, car), managerial steps (planning, organizing and controlling), or a system in a multi-level structure. The component may be simple or complex, basic or advanced. They may be single computer with a keyboard, memory, and printer or a series of intelligent terminals linked to a mainframe. In either case, each component is part of the total system and has to do its share of work for the system to achieve the intended goal. This orientation requires an orderly grouping of the components for the design of a successful system.

3.2 The Systems Theory

The general systems theory states that a system is composed of inputs, a process, outputs, and control. A general graphic representation of such a system is shown below.

Fig. 8.1: An Operational System

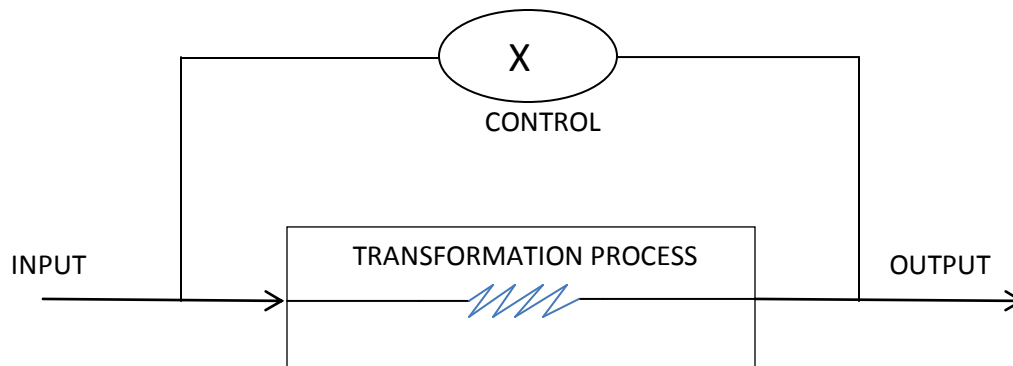

Adapted from Ihemeje, (2002), Fundamentals of Business Decision Analysis, Lagos-Sibon Books Limited.

The input usually consists of people, material or objectives. The process consists of plant, equipment and personnel. While the output usually consists of finished goods, semi-finished goods, policies, new products, ideas, etc.

The purpose of a system is to transform inputs into outputs. The system theory is relevant in the areas of systems design, systems operation and system control. The systems approach helps in resolving organisational problems by looking at the organisation as a whole, integrating its numerous complex operations, environment, technologies, human and material resources. The need to look at the organisation in totality is premised on the fact that the objective if the different units of the organisation when pursued in isolation conflict with one another. For instance, the operation of a manufacturing department favours long and uninterrupted production runs with a view to minimising unit cost of production, including set-up costs. However, this will result in large inventories, and leading to high inventory costs. The finance department seeks to minimise costs as well as capital tied down in inventories. Thus, there is a desire for rapid inventory turnover resulting in lower inventory levels. The marketing department seeks favourable customer service and as a result, will not support any policy that encourages stock outs or back ordering. Back ordering is a method of producing later to satisfy a previously unfulfilled order. Consequently, marketing favours the maintenance of high inventory levels in a wide variety of easily accessible locations which in effect means some type of capital investment in warehouse or sales outlets. Finally, personnel department aims at stabilizing labour, minimizing the cost of firing and hiring as well as employee discontentment. Hence, it is desirable from the point of view of personnel to maintain high inventory level of producing even during periods of fall in demand.

3.3 Elements of a System

Following are considered as the elements of a system in terms of Information systems:

- Input

- Output
 - Processor
 - Control
 - Feedback
-
- **INPUT:** Input involves capturing and assembling elements that enter the system to be processed. The inputs are said to be fed to the systems in order to get the output. For example, input of a 'computer system' is input unit consisting of various input devices like keyboard, mouse, joystick etc.
 - **OUTPUT:** The element that exists in the system due to the processing of the inputs is known as output. A major objective of a system is to produce output that has value to its user. The output of the system maybe in the form of cash, information, knowledge, reports, documents etc. The system is defined as output is required from it. It is the anticipatory recognition of output that helps in defining the input of the system. For example, output of a 'computer system' is output unit consisting of various output devices like screen and printer etc.
 - **PROCESSOR(S):** The processor is the element of a system that involves the actual transformation of input into output. It is the operational component of a system. For example, processor of a 'computer system' is central processing unit that further consists of arithmetic and logic unit (ALU), control unit and memory unit etc.
 - **CONTROL:** The control element guides the system. It is the decision-making sub-system that controls the pattern of activities governing input, processing and output. It also keeps the system within the boundary set. For example, control in a 'computer system' is maintained by the control unit that controls and coordinates various units by means of passing different signals through wires.
 - **FEEDBACK:** Control in a dynamic system is achieved by feedback. Feedback measures output against a standard in some form of cybernetic procedure that includes communication and control. The feedback may generally be of three types viz., positive, negative and informational. The positive feedback motivates the persons in the system. The negative indicates need of an action, while the information. The feedback is a reactive form of control. Outputs from the process of the system are fed back to the control mechanism. The control mechanism then adjusts the control signals to the process on the basis of the data it receives. Feed forward is a protective form of control. For example, in a 'computer system' when logical decisions are taken, the logic unit concludes by comparing the calculated results and the required results.

3.4 Types of Systems

Systems are classified in different ways:

1. Physical or abstract systems.
2. Open or closed systems.
3. 'Man-made' information systems.
4. Formal information systems.
5. Informal information systems.
6. Computer-based information systems.
7. Real-time system.

Physical systems are tangible entities that may be static or dynamic in operation.

An open system has many interfaces with its environment. i.e. system that interacts freely with its environment, taking input and returning output. It permits interaction across its boundary; it receives inputs from and delivers outputs to the outside. A closed system does not interact with the environment; changes in the environment and adaptability are not issues for closed system.

3.5 Forms of systems

A system can be conceptual, mechanical or social. A system can also be deterministic or probabilistic. A system can be closed or open.

Conceptual system

A system is conceptual when it contains abstracts that are linked to communicate ideas. An example of a conceptual system is a language system as in English language, which contains words, and how they are linked to communicate ideas. The elements of a conceptual system are words.

Mechanical system

A system is mechanical when it consists of many parts working together to do a work. An example of a social system is a typewriter or a computer, which consists of many parts working together to type words and symbols. The elements of the mechanical system are objects.

Social system

A system is social when it comprises policies, institutions and people. An example of a social system is a football team comprising 11 players, or an educational system consisting of policies, schools and teachers. The elements of a social system are subjects or people.

Deterministic system

A system is deterministic when it operates according to a predetermined set of rules. Its future behaviour can therefore be predicted exactly if it's present state and operating characteristics are accurately known. Examples of deterministic systems are computer

programmes and a planet in orbit. Business systems are not deterministic owing to the fact that they interfere with a number of determinant factors, such as customer and supplier behaviour, national and international situations, and climatic and political conditions.

Probabilistic system

A system is probabilistic when the system is controlled by chance events and so its future behaviour is a matter of probability rather than certainty. This is true of all social systems, particularly business enterprises. Information systems are deterministic enterprises in the sense that a pre-known type and content of information emerges as a result of the input of a given set of data.

Closed system

A system is closed when it does not interface with its environment i.e. it has no input or output. This concept is more relevant to scientific systems than to social systems. The nearest we can get to a closed social system would be a completely self-contained community that provides all its own food, materials and power, and does not trade, communicate or come into contact with other communities.

Open system

A system is open when it has many interfaces with its environment, and so needs to be capable of adopting their behaviour in order to continue to exist in changing environments. An information system falls into this category since it needs to adapt to the changing demands for information. Similarly, a business system must be capable of reorganizing itself to meet the conditions of its environment, as detected from its input; it will more rapidly tend towards a state of disorganization. (Ihemeje, 2002)

3.6 The Concept of Entropy in a System

The term entropy is used as a measure of disorganisation. Thus, we can regard open systems as tending to increase their entropy unless they receive negative entropy in the form of information from their environment. In the above example, if increased cost of cost of materials were ignored, the product will become unprofitable and as a result, the organisation may become insolvent, that is, a state of disorganisation.

4.0 CONCLUSION

In our everyday life, the word system is widely used. It has become fashionable to attach the word system to add a contemporary flair when referring to things or processes. People speak of exercise system, investment system, delivery system, information system, education system, computer system etc. System may be referred to any set of components, which function in interrelated manner for a common cause or objective.

A system exists because it is designed to achieve one or more objectives. We come into daily contact with the transportation system, the telephone system, the accounting system,

the production system, and, for over two decades, the computer system. Similarly, we talk of the business system and of the organization as a system consisting of interrelated departments (subsystems) such as production, sales, personnel, and an information system.

5.0 SUMMARY

This unit discusses the concept of systems analysis. The origin of system analysis has been traced to the Greek word *systema*, which means an organized relationship among functioning units or components. A system exists because it is designed to achieve one or more objectives. It can be defined as a collection of elements or components or units that are organized for a common purpose. The general systems theory states that a system is composed of inputs, a process, outputs, and control. The input usually consists of people, material or objectives. The process consists of plant, equipment and personnel. While the output usually consists of finished goods, semi-finished goods, policies, new products, ideas, etc. A system consists of the following elements: input, output, processor, control, feedback, boundary and interface, and environment. Depending on the usage, a system has the following types of systems: Physical or abstract systems, Open or closed systems, Man-made information systems, Formal information systems, Informal information systems, Computer-based information systems and Real-time system. A system can be conceptual, mechanical or social. A system can also exist in the following forms- it can be deterministic or probabilistic, closed or open, mechanical, social, and conceptual.

It has been quite an exciting journey through the world of systems analysis.

6.0 TUTOR MARKED ASSIGNMENT

- 1 What do you understand term system?
- 2 With the aid of a well labelled diagram, describe how a system works.
- 3 What understand by the concept of entropy of a system?
- 4 List and explain the elements of a system.

7.0 REFERENCES

Ihemeje, J.C. (2002). Fundamentals of Business Decision Analysis, Lagos- Sibon Books.

Jawahar, S. (2006). Overview of System Analysis & Design- Lesson Note no. 1.

MODULE FOUR

UNIT 1: SEQUENCING

1.0 Introduction

2.0 Objectives

3.0 Main Content

3.1 The Problem:(Definition)

3.2 Assumptions Made in Sequencing Problems

3.3 Nature of Scheduling

3.4 Loading Jobs in Work Centres

3.4.1 Gantt Charts

3.4.2 Assignment Method

3.5 Priority Rules for Job Sequencing

3.6 Applicability

3.7 Types of Sequencing Problems

3.7.1 Sequencing Jobs in two Machines

4.0 Conclusion

5.0 Summary

6.0 Tutor Marked Assignment

7.0 References

1.0 INTRODUCTION

Sequencing problems involves the determination of an optimal order or sequence of performing a series jobs by number of facilities (that are arranged in specific order) so as to optimize the total time or cost. Sequencing problems can be classified into two groups:

The group involves n different jobs to be performed, and these jobs require processing on some or all of m different types of machines. The order in which these machines are to be used for processing each job (for example, each job is to be processed first on machine A, then B, and thereafter on C i.e., in the order ABC) is given. Also, the expected actual processing time of each job on each machine is known. We can also determine the effectiveness for any given sequence of jobs on each of the machines and we wish to select from the $(n!)^m$ theoretically feasible alternatives, the one which is both technologically feasible and optimises the effectiveness measure.

OBJECTIVES

After completing this chapter, you should be able to:

- Explain what scheduling involves and the nature of scheduling.
- Understand the use of Gantt charts and assignment method for loading jobs in work centres.

- Discuss what sequencing involves and the use of priority rules.
- Solve simple problems on scheduling and sequencing.

3.1 DEFINITION

Scheduling refers to establishing the timing of the use of equipment, facilities and human activities in an organization, that is, it deals with the timing of operations. Scheduling occurs in every organization, regardless of the nature of its operation. For example, manufacturing organizations, hospitals, colleges, airlines e.t.c. schedule their activities to achieve

greater efficiency. Effective Scheduling helps companies to use assets more efficiently, which leads to cost savings and increase in productivity. The flexibility in operation provides faster delivery and therefore, better customer service. In general, the objectives of scheduling are to achieve trade-offs among conflicting goals, which include efficient utilization of staff, equipment and facilities and minimization of customer waiting time, inventories and process times (Adebayo et al, 2006).

3.2 ASSUMPTIONS MADE IN SEQUENCING PROBLEMS

Principal assumptions made for convenience in solving the sequencing problems are as follows:

- 1 The processing times A_i and B_i etc. are exactly known to us and they are independent of order of processing the job on the machine. That is whether job is done first on the machine, last on the machine, the time taken to process the job will not vary it remains constant.
- 2 The time taken by the job from one machine to other after processing on the previous machine is negligible. (Or we assume that the processing time given also includes the transfer time and setup time).
- 3 Only one operation can be carried out on a machine at a particular time.
- 4 Each job once started on the machine, we should not stop the processing in the middle. It is to be processed completely before loading the next job.
- 5 The job starts on the machine as soon as the job and the machine both become idle (vacant). This is written as job is next to the machine and the machine is next to the job. (This is exactly the meaning of transfer time is negligible).

3.3 Nature of Scheduling

Scheduling technique depends on the volume of system output, the nature of operations and the overall complexity of jobs. Flow shop systems require approaches substantially different from those required by job shops. The complexity of operations varies under these two situations.

1. Flow Shop

Flow shop is a high-volume system, which is characterized by a continuous flow of jobs to produce standardized products. Also, flow shop uses standardized equipment (i.e.

special purposed machines) and activities that provide mass production. The goal is to obtain a smooth rate of flow of goods or customer through the system in order to get high utilization of labour and equipment. Examples are refineries, production of detergents etc.

2. Job Shop

This is a low volume system, which periodically shift from one job to another. The production is according to customer's specifications and orders or jobs usually in small lots. General-purpose machines characterize Job shop. For example, in designer shop, a customer can place order for different design.

Job-shop processing gives rise to two basic issues for schedulers: how to distribute the workload among work centre and what job processing sequence to use.

3.4 Loading Jobs in Work Centres

Loading refers to the assignment of jobs to work centres. The operation managers are confronted with the decision of assigning jobs to work centres to minimize costs, idle time or completion time.

The two main methods that can be used to assign jobs to work centres or to allocate resources are:

1. Gantt chart
2. Assignment method of linear programming

3.4.1 Gantt Charts

Gantt charts are bar charts that show the relationship of activities over some time periods. Gantt charts are named after Henry Gantt, the pioneer who used charts for industrial scheduling in the early 1900s. A typical Gantt chart presents time scale horizontally, and resources to be scheduled are listed vertically, the use and idle times of resources are reflected in the chart.

The two most commonly used Gantt charts are the schedule chart and the load chart.

3.4.2 Assignment Method

Assignment Model (AM) is concerned specifically with the problem of job allocation in a multiple facility production configuration. That is, it is useful in situations that call for assigning tasks or jobs to resources. Typical examples include assigning jobs to machines or workers, territories to sales people e.t.c. One important characteristic of assignment problems is that only one job (or worker) is assigned to one machine (or project). The idea is to obtain an optimum matching of tasks and resources. A chapter in this book has treated the assignment method.

3.5 PRIORITY RULES FOR JOB SEQUENCING

Priority rules provide means for selecting the order in which jobs should be done (processed). In using these rules, it is assumed that job set up cost and time are independent of processing sequence. The main objective of priority rules is to minimize completion time, number of jobs in the system, and job lateness, while maximizing facility utilization. The most popular priority rules are:

1. First Come, First Serve (FCFS): Job is worked or processed in the order of arrivals at the work centre.
2. Shortest Processing Time (SPT): Here, jobs are processed based on the length of processing time. The job with the least processing time is done first.
3. Earliest Due Date (EDD): This rule sequences jobs according to their due dates, that is, the job with the earliest due date is processed first.
4. Longest Processing Time (LPT): The job with the longest processing time is started first.
5. Critical Ratio: Jobs are processed according to smallest ratio of time remaining until due date to processing time remaining.

The effectiveness of the priority rules is frequently measured in the light of one or more performance measures namely; average number of jobs, job flow time, job lateness, make span, facility utilisation etc.

3.6 Applicability

The sequencing problem is very much common in Job workshops and Batch production shops. There will be number of jobs which are to be processed on a series of machine in a specified order depending on the physical changes required on the job. We can find the same situation in computer centre where number of problems waiting for a solution. We can also see the same situation when number of critical patients waiting for treatment in a clinic and in Xerox centres, where number of jobs is in queue, which are to be processed on the Xerox machines. Like this we may find number of situations in real world.

3.7 Types of Sequencing Problems

There are various types of sequencing problems arise in real world. All sequencing problems cannot be solved. Though mathematicians and Operations Research scholars are working hard on the problem satisfactory method of solving problem is available for few cases only. The problems, which can be solved, are:

- (a) ' n ' jobs are to be processed on two machines say machine A and machine B in the order AB . This means that the job is to be processed first on machine A and then on machine B .
- (b) ' n ' jobs are to be processed on three machines A, B and C in the order ABC i.e. first on machine A , second on machine B and third on machine C .
- (c) ' n ' jobs are to be processed on ' m ' machines in the given order.
- (d) Two jobs are to be processed on ' m ' machines in the given order. (Murthy, 2007)

- **Single Machine Scheduling Models**

The models in this section deal with the simplest of scheduling problems: there is only a single machine on which tasks are to be processed. Before investigating the solutions that result from the use of the three criteria presented in the introduction

- **‘N’ Jobs and Two Machines**

If the problem given has two machines and two or three jobs, then it can be solved by using the Gantt chart. But if the numbers of jobs are more, then this method becomes less practical. (For understanding about the Gantt chart, the students are advised to refer to a book on Production and Operations Management (chapter on Scheduling). Gantt chart consists of *X* -axis on which the time is noted and *Y*-axis on which jobs or machines are shown. For each machine a horizontal bar is drawn. On these bars the processing of jobs in given

sequence is marked. Let us take a small example and see how Gantt chart can be used to solve the same.

EXAMPLE 1

There are two jobs job 1 and job 2. They are to be processed on two machines, machine *A* and Machine *B* in the order *AB*. Job 1 takes 2 hours on machine *A* and 3 hours on machine *B*. Job 2 takes 3 hours on machine *A* and 4 hours on machine *B*. Find the optimal sequence which minimizes the total elapsed time by using Gantt chart.

Solution

<i>Jobs.</i>	<i>Machines (Time in hours)</i>	
	<i>A</i>	<i>B</i>
<i>1</i>	<i>2</i>	<i>3</i>
<i>2</i>	<i>3</i>	<i>4</i>

(a) Total elapsed time for sequence 1,2*i.e.* first job 1 is processed on machine *A* and then on second machine and so on.

Draw *X* - axis and *Y*- axis, represent the time on *X* - axis and two machines by two bars on *Yaxis*. Then mark the times on the bars to show processing of each job on that machine.

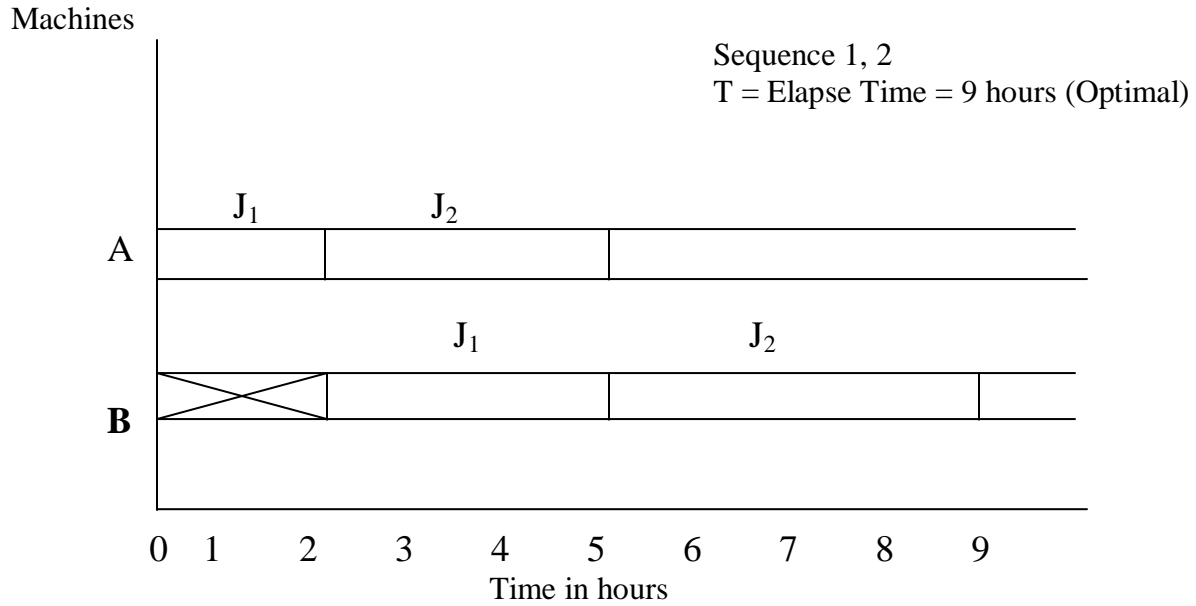

Sequence 1, 2
T = Elapse Time = 9 hours (Optimal sequence)

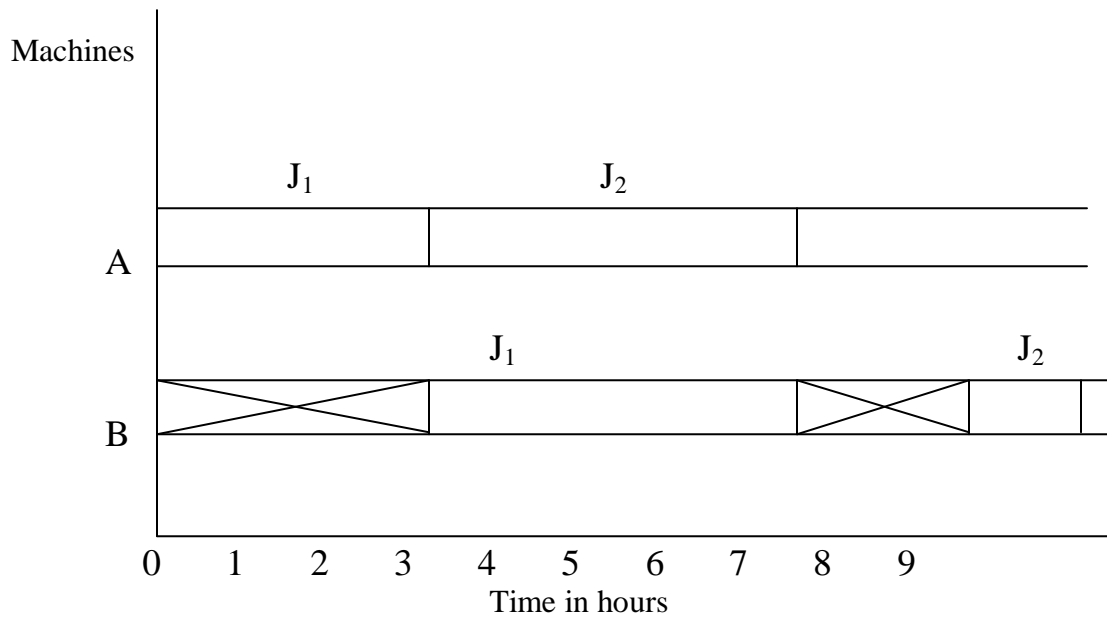

Fig. 13.1: Gantt chart.

Source: Murthy, R. P. (2007), *Operations Research, 2nd ed.*, New Delhi: New Age International (P) Limited Publisher

Both the sequences shows the elapsed time = 9 hour

The drawback of this method is for all the sequences, we have to write the Gantt chart and find the total elapsed times and then identify the optimal solution. This is laborious and time consuming. If we have more jobs and more machines, then it is tedious work to draw the chart for all sequences.

Hence we have to go for analytical methods to find the optimal solution without drawing charts.

1 Analytical Method

A method has been developed by **Johnson and Bellman** for simple problems to determine a sequence of jobs, which minimizes the total elapsed time. The method:

1. 'n' jobs are to be processed on two machines A and B in the order AB (i.e. each job is to be processed first on A and then on B) and passing is not allowed. That is whichever job is processed first on machine A is to be first processed on machine B also, whichever job is processed second on machine A is to be processed second on machine B also and so on. That means each job will first go to machine A get processed and then go to machine B and get processed. *This rule is known as no passing rule.*

2. Johnson and Bellman method concentrates on minimizing the idle time of machines. Johnson and Bellman have proved that optimal sequence of 'n' jobs which are to be processed on two machines A and B in the order AB necessarily involves the same ordering of jobs on each machine. This result also holds for three machines but does not necessarily hold for more than three machines. Thus total elapsed time is minimum when the sequence of jobs is same for both the machines.

3. Let the number of jobs be 1,2,3,.....n
 The processing time of jobs on machine A be $A_1, A_2, A_3 \dots \dots \dots A_n$
 The processing time of jobs on machine B be $B_1, B_2, B_3 \dots \dots \dots B_n$

Jobs	Machine Time in Hours		Order of Processing is AB
	Machine A	Machine B	
1	A_1	B_1	
2	A_2	B_2	
3	A_3	B_3	
.....	
I	A_I	B_I	
.....	
S	A_S	B_S	
.....	
T	A_T	B_T	
.....	

N	A_N	B_N	
-----	-------	-------	--

4. Johnson and Bellman algorithm for optimal sequence states *that identify the smallest element in the given matrix. If the smallest element falls under column 1 i.e under machine 1 then do that job first. As the job after processing on machine 1 goes to machine 2, it reduces the idle time or waiting time of machine 2. If the smallest element falls under column 2 i.e under machine 2 then do that job last. This reduces the idle time of machine 1. i.e. if r the job is having smallest element in first column, then do the r^{th} job first. If s the job has the smallest element, which falls under second column, then do the s the job last. Hence the basis for Johnson and Bellman method is to keep the idle time of machines as low as possible. Continue the above process until all the jobs are over.*

1	2	$3 \dots \dots \dots$	$n-1$	n
r				s

If there are ‘ n ’ jobs, first write ‘ n ’ number of rectangles as shown. Whenever the smallest elements falls in column 1 then enter the job number in first rectangle. If it falls in second column, then write the job number in the last rectangle. Once the job number is entered, the second rectangle will become first rectangle and last but one rectangle will be the last rectangle.

5. Now calculate the total elapsed time as discussed. Write the table as shown. Let us assume that the first job starts at Zero th time. Then add the processing time of job (first in the optimal sequence) and write in out column under machine 1. This is the time when the first job in the optimal sequence leaves machine 1 and enters the machine 2. Now add processing time of job on machine 2. This is the time by which the processing of the job on two machines over. Next consider the job, which is in second place in optimal sequence. This job enters the machine 1 as soon the machine becomes vacant, i.e first job leaves to second machine. Hence enter the time in-out column for first job under machine 1 as the starting time of job two on machine 1. Continue until all the jobs are over. Be careful to see that whether the machines are vacant before loading. Total elapsed time may be worked out by drawing Gantt chart for the optimal sequence.
6. Points to remember:

(a) If there is tie i.e we have smallest element of same value in both columns, then:
 (i) Minimum of all the processing times is A_r which is equal to B_s i.e. $\text{Min}(A_i, B_i) = A_r = B_s$ then do the r th job first and s th job last.
 (ii) If $\text{Min}(A_i, B_i) = A_r$ and also $A_r = A_k$ (say). Here tie occurs between the two jobs having same minimum element in the same column i.e. first column we can do either r th job or k th job first. There will be two solutions. When the ties occur due to element in the same column, then the problem will have alternate solution. If more number of jobs have the same minimum element in the same column, then the problem will have many alternative solutions. If we start writing all the solutions, it is a tedious job. Hence it is enough that the students can mention that the problem has alternate solutions. The same is true with B_i s also. If more number of jobs have same minimum element in second column, the problem will have alternate solutions.

Example 2

There are seven jobs, each of which has to be processed on machine A and then on Machine B (order of machining is AB). Processing time is given in hour. Find the optimal sequence in which the jobs are to be processed so as to minimize the total time elapsed.

JOB:	1	2	3	4	5	6	7
MACHINE: A (TIME IN HOURS).	3	12	15	6	10	11	9
MACHINE: B (TIME IN HOURS).	8	10	10	6	12	1	3

Solution

By Johnson and Bellman method the optimal sequence is:

1	4	5	3	2	7	6
---	---	---	---	---	---	---

Optimal Sequence	Machine:A		Machine:B		Machine idle time		Job idle time	Remarks.
	In	out	In	out	A	B		
1	0	3	3	11		3	-	
4	3	9	11	17			2	Job finished early
5	9	19	19	31		2		Machine A take more time
3	19	34	34	44		3		Machine A takes more time.
2	34	46	46	56		2		- do-
7	46	55	56	59			1	Job finished early.
6	55	66	66	67	1	7		Machine A takes more time. Last is finished on machine A at 66 th hour.
	Total		Elapsed		Time = 67 houN			

Example 3

Assuming eight jobs are waiting to be processed. The processing time and due dates for the jobs are given below: Determine the sequence processing according to (a) FCFS (b) SPT (c) EDD and (d) LPT in the light of the following criteria:

- (i) Average flow time,
- (ii) Average number of jobs in the system,
- (iii) Average job lateness,
- (iv) Utilization of the workers

JOB	PROCESSING TIME	DUE DATE (DAYS)
A	4	9
B	10	18
C	6	6
D	12	19
E	7	17
F	14	20
G	9	24
H	18	28

Solution:

(a) To determine the sequence processing according to FCFS

The FCFS sequence is simply A-B-C-D-E-F-G-H- as shown below

Job	Processing Time	Flow time	Job due date	Job lateness (0 of negative)
A	4	4	9	0
B	10	14	18	0
C	6	20	6	14
D	12	32	19	13
E	7	39	17	22
F	14	53	20	33
G	9	62	24	38
H	18	80	28	52
	80	304		172

The first come, first served rule results is the following measures of effectiveness:

1. Average flow time =
$$\frac{\text{Sum of total flow time}}{\text{Number of jobs}}$$

$$= \frac{304\text{days}}{8} = 38\text{jobs}$$

2. Average number of jobs in the system = $\frac{\text{Sum of total flow time}}{\text{Total processing time}}$

$$= \frac{304\text{days}}{80} = 3.8\text{jobs}$$

3. Average job lateness = $\frac{\text{Total late days}}{\text{Number of days}} = \frac{172}{8} \times 21.5 = 22\text{days}$

4. Utilization = $\frac{\text{Total processing time}}{\text{Sum of total flow time}} = \frac{80}{304} = 0.2631579$
 $0.2631579 \times 100\% = 26.31579 = 26.32\%$

(b) To determine the sequence processing according to SPT
 SPT processes jobs based on their processing times with the highest priority given to the job with shortest time as shown below:

Job	Processing Time	Flow time	Job due date	Job lateness (0 of negative)
A	4	4	9	0
B	6	10	6	4
C	7	17	17	0
D	9	26	24	2
E	10	36	18	18
F	12	48	19	29
G	14	62	20	42
H	18	80	28	52
	80	283		147

The measure of effectiveness are:

1. Average flow time = $\frac{\text{Sum of total flow time}}{\text{Number of jobs}} = \frac{283}{8}$
 $= 35.375\text{days} = 35.38 \text{ days}$

2. Average number of jobs in the system = $\frac{\text{Sum of total flow time}}{\text{Total processing time}}$

$$= \frac{283 \text{days}}{80} = 3.54 \text{jobs}$$

$$3. \quad \text{Average job lateness} = \frac{\text{Total late days}}{\text{Number of days}} = \frac{147}{8}$$

$$= 18.375 \text{days}$$

$$= 18.38 \text{days}$$

$$4. \quad \text{Utilization} = \frac{\text{Total processing time}}{\text{Sum of total flow time}} = \frac{80}{283}$$

$$0.2826855 \times 100\%$$

$$= 28.27\%$$

(c) To determine the sequence processing according to EDD

Using EDD, you are processing based on their due dates as shown below:

Job	Processing Time	Flow time	Job due date	Job lateness (0 of negative)
A	6	6	6	0
B	4	10	9	1
C	7	17	17	0
D	9	27	18	9
E	10	39	19	20
F	12	53	20	33
G	14	62	24	38
H	18	80	28	52
	80	294		153

The measure of effectiveness are:

$$1. \quad \text{Average flow time} = \frac{294}{8} = 36.75 \text{days}$$

$$2. \quad \text{Average number of jobs in the system} = \frac{294}{80}$$

$$3.675 = 3.68 \text{days}$$

3. Average job lateness = $\frac{153}{8} = 19.125$

= 19.13days

=18.38days

4. Utilization = $\frac{80}{294} = 0.272108843$

0.282108843 x 100

= 27.21%

(d) **To Determine the Sequence Processing According to LPT**

LPT selects the longer, bigger jobs first as presented below:

Job	Processing Time	Flow time	Job due date	Job lateness (0 of negative)
A	18	18	28	0
B	14	32	20	12
C	12	44	19	25
D	10	54	18	36
E	9	63	24	39
F	7	70	17	53
G	6	76	6	70
H	4	80	9	71
	80	437		306

The measure of effectiveness are:

1. Average flow time = $\frac{437}{8} = 54.625$ days

8

= 54.63days

2. Average number of jobs in the system = $\frac{437}{80} = 5.4625$

80

5.46days

3. Average job lateness = $\frac{306}{8} = 38.25$ days

8

4. Utilization = $\frac{80}{437} = 0.183066361$

0.183066361 x 100%

= 18.31%

The summary of the rules are shown in the table below:

	Average flow time (days)	Average number of jobs in the system	Average job lateness job	Utilization%
FCFS	38	3.8	21.5	26.32
SPT	35.38	3.54	18.38	28.27
EDD	36.75	3.68	19.13	27.21
LPT	54.63	5.46	38.25	18.31

As it can be seen from the table, SPT rule is the best of the four measures and is also the most superior in utilization of the system. On the other hand, LPT is the least effective measure of the three,

3.7.1 SEQUENCING JOBS IN TWO MACHINES

Johnson's rule is used to sequence two or more jobs in two different machines or work centres in the same order. Managers use Johnson rule method to minimize total timer for sequencing jobs through two facilities. In the process, machine total idle time is minimised. The rule does not use job priorities.

Johnson's rule involves the following procedures

- 1) List the jobs and their respective time requirement on a machine.
- 2) Choose the job with the shortest time. if the shortest time falls with the first machine, schedule that job first; if the time is at the second machine, schedule the job last. Select arbitrary any job if tie activity time occur.
- 3) Eliminate the scheduled job and its time
- 4) Repeat steps 2 and 3 to the remaining jobs, working toward the centre of the sequence until all the jobs are properly scheduled.

Example 4

You are given the operation times in Hours for 6 jobs in two machines as follow:

Job	Machine 1 Time (Hours)	Machines 2 Time (Hours)
P	20	20
Q	16	12
R	33	36
S	8	28
T	25	33
U	48	60

- (a) Determine the sequence that will minimize idle times on the two machines
- (b) The time machine I will complete its jobs
- (c) The total completion time for all the jobs
- (d) The total idle time

Solution

Using the steps outlined earlier for optimum sequencing of jobs, we obtained

1 st	2 nd	3 rd	4 th	5 th	6 th
S	T	R	U	E	Q

We then use tabular method to solve the remaining questions

Job sequence	I Machine 1 Duration	II Machine 1 in	III Machine 1 Out	IV Machine 2 Duration	V Machine 2 In	VI Machine 2 Out	VII Idle Time
S	8	0	8	28	8	36	8
T	25	8	33	33	36	69	0
R	33	33	66	36	69	105	0
U	48	66	114	60	114	174	9
P	20	114	134	20	174	194	0
Q	16	134	150	12	194	206	0

- (a) Machine 1 will complete his job in 150 hours
- (b) Total completion time is 206 hours
- (c) Total idle time is 17 hours

Note that machine 2 will wait 8 hours for its first job and also wait 9 hours after completing job R.

In general, idle time can occur either at the beginning of job or at the end of sequence of jobs. In manufacturing organizations, idle times can be used to do other jobs like maintenance, dismantling or setting up of other equipment.

4.0 CONCLUSION

Sequencing problems involves the determination of an optimal order or sequence of performing a series jobs by number of facilities (that are arranged in specific order) so as to optimize the total time or cost. Sequencing problems can be classified into two groups. The first group involves n different jobs to be performed, and these jobs require processing on some or all of m different types of machines. The order in which these machines are to be used for processing each job (for example, each job is to be processed first on machine A, then B, and thereafter on C i.e., in the order ABC) is given.

5.0 SUMMARY

Scheduling, which occurs in every organisation, refers to establishing the timing of the use of equipment, facilities and human activities in an organization and so it deals with the timing of operations. Scheduling technique depends on the volume of system output, the nature of operations and the overall complexity of jobs. The complexity of operation varies under two situations, namely, Flow Shop system and Job Shop system. Flow Shop is a high volume system while Job Shop is a low volume system. Lading refers to assignment of jobs to work centres. The two main methods that can be used to assign jobs to work centres are used of Gant chart and Assignment Method. Job sequencing refers to the order in which jobs should be processed at each work station.

6.0 TUTOR MARKED ASSIGNMENT

1. Explain the following concepts (a) Scheduling (b) Flow shop (c)Job shop(d) Sequencing
2. Describe two main methods used to assign jobs to work centres
3. Define the following (a) Average flow time (b) Average number of jobs in the system (c) Utilization
4. State the priority rules for sequencing

7.0 REFERENCES

- Adebayo, O.A., Ojo, O., and Obamire, J.K. (2006). Operations Research in Decision Analysis, Lagos: Pumark Nigeria Limited.
- Denardo, Eric V. (2002). The Schience of Decision making: A Problem-Based Approach Using Excel. New York: John Wiley.

Gupta, P.K., and Hira, D.S. (2012) Operations Research, New – Delhi: S. Chand & Company.

Gupta, P.K., and Hira, D.S. (2012). Operations Research, New – Delhi: S. Chand & Company.

UNIT 2: GAMES THEORY

- 1.0 Introduction
- 2.0 Objection
- 3.0 Main Content
 - 3.1 Decision making
 - 3.2 Description of a Game
 - 3.3 Some Important Definitions in Games Theory
 - 3.4 Assumptions Made in Games Theory
 - 3.5 Description and Types of Games
 - 3.5.1 Two-Person Zero-Sum Game
 - 3.5.2 Pure Strategies
 - 3.5.3 Dominating Strategies
 - 3.5.4 Mixed Strategies
 - 3.5.5 Optimal Strategies in 2 X 2 Matrix Game
 - 3.5.6 Equilibrium Pairs
 - 3.5.7 Optimal Strategies in 2 X N Matrix Game
 - 3.5.8 Optimal Strategies for M X 2 Zero - Sum Games
- 4.0 Conclusion
- 5.0 Summary
- 6.0 Tutor Marked Assignment
- 7.0 References

1.0 INTRODUCTION

The theory of games (or game theory or competitive strategies) is a mathematical theory that deals with the general features of competitive situations. This theory is helpful when two or more individuals or organisations with conflicting objectives try to make decisions. In such a situation, a decision made by one person affects the decision made by one or more of the remaining decision makers, and the final outcome depends upon the decision of all the parties. (Gupta and Hira, 2012)

According to Adebayo et al (2006), Game theory is a branch of mathematical analysis used for decision making in conflict situations. It is very useful for selecting an optimal strategy or sequence of decision in the face of an intelligent opponent who has his own strategy. Since more than one person is usually involved in playing of games, game theory can be described as the theory of multiplayer decision problem. The Competitive strategy is a system for describing games and using mathematical techniques to convert practical problems into games that need to be solved. Game theory can be described as a distinct and interdisciplinary approach to the study of human behaviour and such disciplines include mathematics, economics, psychology and other social and behavioural sciences. If properly understood it is a good law for studying decision-making in conflict situations and it also provides mathematical techniques for selecting optimum strategy

and most rational solution by a player in the face of an opponent who already has his own strategy.

2.0 OBJECTIVES

By the end of this chapter, you will be able to:

- Define the concept of a game
- State the assumptions of games theory
- Describe the two-person zero-sum games
- Explain the concept of saddle point solution in a game

3.0 MAIN CONTENT

3.1 DECISION MAKING

Making decision is an integral and continuous aspect of human life. For child or adult, man or woman, government official or business executive, worker or supervisor, participation in the process of decision-making is a common feature of everyday life. What does this process of decision making involve? What is a decision? How can we analyze and systematize the solving of certain types of decision problems? Answers of all such question are the subject matter of decision theory. Decision-making involves listing the various alternatives and evaluating them economically and select best among them. Two important stages in decision-making is: (i) making the decision and (ii) Implementation of the decision.

3.2 DESCRIPTION OF A GAME

In our day-to-day life we see many games like Chess, Poker, Football, Base ball etc. All the games are pleasure-giving games, which have the character of a competition and are played according to well- structured rules and regulations and end in a *victory* of one or the other team or group or a player. But we refer to the word game in this unit the competition between two business organizations, which has more earning competitive situations. In this chapter game is described as:

A competitive situation is called a game if it has the following characteristics (Assumption made to define a game):

1. There is finite number of competitors called *Players*. This is to say that the game is played by two or more number of business houses. The game may be for creating new market, or to increase the market share or to increase the competitiveness of the product.
2. A play is played when each player chooses one of his courses of actions. The choices are made simultaneously, so that no player knows his opponent's choice until he has decided his own course of action. But in real world, a player makes the choices after the opponent has announced his course of action.

Algebraic Sum of Gains and Losses: A game in which the gains of one player are the losses of other player or the algebraic sum of gains of both players is equal to zero, the game is known as Zero sum game (ZSG). In a zero sum game the algebraic sum of the gains of all players after play is bound to be zero. i.e. If g_i as the pay of to a player in an- person game, then the game will be a zero sum game if sum of all g_i is equal to zero.

In game theory, the resulting gains can easily be represented in the form of a matrix called pay-off matrix or gain matrix as discussed in 3 above. A pay- off matrix is a table, which shows how payments should be made at end of a play or the game. Zero sum game is also known as constant sum game. Conversely, if the sum of gains and losses does not equal to zero, the game is a non zero-sum game. A game where two persons are playing the game and the sum of gains and losses is equal to zero, the game is known as Two-Person Zero-Sum Game (TPZSG). A good example of two- person game is the game of chess. A good example of n- person game is the situation when several companies are engaged in an intensive advertising campaign to capture a larger share of the market (Murthy, 2007)

3.3 SOME IMPORTANT DEFINITIONS IN GAMES THEORY

Adebayo et al (2010) provide the following important definitions in game theory.

- **Player:** A player is an active participant in a game. The games can have two persons(Two-person game) or more than two persons (Multi person or n-person game)
- **Moves:** A move could be a decision by player or the result of a chance event.
- **Game:** A game is a sequence of moves that are defined by a set of rules that governs the players' moves. The sequence of moves may be simultaneous.
- **Decision maker:** A decision-maker is a person or group of people in a committee who makes the final choice among the alternatives. A decision-maker is then a player in the game.
- **Objective:** An objective is what a decision-maker aims at accomplishing by means of his decision. The decision-maker may end up with more than one objective.
- **Behaviour:** This could be any sequence of states in a system. The behaviours of a system are overt while state trajectories are covert.
- **Decision:** The forceful imposition of a constraint on a set of initially possible alternatives.
- **Conflict:** A condition in which two or more parties claim possession of something they cannot all have simultaneously. It could also be described as a state in which two or more decision-makers who have different objectives, act in the same system or share the same resources. Examples are value conflicts, territorial conflict, conflicts of interests etc.

- **Strategy:** it is the predetermined rule by which a player decides his course of action from a list of courses of action during the game. To decide a particular strategy, the player needs to know the other's strategy.
- **Perfect information.** A game is said to have perfect information if at every move in the game all players know the move that have already been made. This includes any random outcomes.
- **Payoffs.** This is the numerical return received by a player at the end of a game and this return is associated with each combination of action taken by the player. We talk of "expected payoff" if its move has a random outcome.
- **Zero-sum Game.** A game is said to be zero sum if the sum of player's payoff is zero. The zero value is obtained by treating losses as negatives and adding up the wins and the losses in the game. Common examples are baseball and poker games.

3.4 ASSUMPTIONS MADE IN GAMES THEORY

The following are assumptions made in games theory.

- Each player (Decision-maker) has available to him two or more clearly specified choices or sequence of choices (plays).
- A game usually leads to a well-defined end-state that terminates the game. The end state could be a win, a loss or a draw.
- Simultaneous decisions by players are assumed in all games.
- A specified payoff for each player is associated with an end state (eg sum of payoffs for zero sum-games is zero in every end-state).
- Repetition is assumed. A series of repetitive decisions or plays results in a game
- Each decision-maker (player) has perfect knowledge of the game and of his opposition i.e. he knows the rules of the game in details and also the payoffs of all other players. The cost of collecting or knowing this information is not considered in game theory.
- All decision-makers are rational and will therefore always select among alternatives, the alternative that gives him the greater payoff.

The last two assumptions are obviously not always practicable in real life situation. These assumptions have revealed that game theory is a general theory of rational behaviour involving two or more decision makers who have a limit number of courses of action of plays, each leading to a well-defined outcome or ending with games and losses that can be expressed as payoffs associated with each courses of action and for each decision maker. The players have perfect knowledge of the opponent's moves and are rational in taking decision that optimises their individual gain.

The various conflicts can be represented by a matrix of payoffs. Game theory also proposes several solutions to the game. Two of the proposed solutions are:

1. **Minimax or pure Strategy:** In a minimax strategy each player selects a strategy that minimises the maximum loss his opponent can impose upon him.

2. **Mixed Strategy:** A mixed strategy which involves probability choices.

Lot of experiments have been performed on games with results showing conditions for (i) Cooperation (ii) Defection and (iii) Persistence of conflict,

3.5 DESCRIPTION AND TYPES OF GAMES

Games can be described in terms of the number of players and the type of sum obtained for each set of strategies employed. To this end we have the following types of games:

- Two-person zero-sum games. Here two players are involved and the sum of the Pay-offs for every set of strategies by the two players is zero
- Two-person non zero-sum games. Here two players are involved and there is one strategy set for which the sum of the payoffs is not equal to zero.
- Non- Constant sum games. The values of payoffs for this game vary.
- Multi-person non- Constant-Sum games. Many players are involved in the game and the payoffs for the players vary.

3.5.1 TWO-PERSON ZERO-SUM GAME

This game involves two players in which losses are treated as negatives and wins as positives and the sum of the wins and losses for each set of strategies in the game is zero. Whatever player one wins player two loses and vice versa. Each player seeks to select a strategy that will maximise his payoffs although he does not know what his intelligence opponent will do. A two-person zero-sum game with one move for each player is called a rectangular game.

Formally, a two-person zero-sum game can be represented as a triple (A, B, γ) where A $[a_1, a_2, \dots, a_m]$ and B $[b_1, b_2, \dots, b_n]$ and are payoff functions, e_{ij} such that $\gamma [a_i, b_j] = e_{ij}$. This game can be represented as an $m \times n$ matrix of payoffs from player 2 to player 1 as follows:

$$\begin{bmatrix} \gamma [a_1, b_1] & \gamma [a_1, b_2] & \dots & \gamma [a_1, b_n] \\ \gamma [a_m, b_1] & \gamma [a_m, b_2] & \dots & \gamma [a_m, b_n] \end{bmatrix}$$

The two-person zero-sum games can also be represented as follows:

Suppose the choices or alternatives that are available for player 1 can be represented as 1,2,3...m. While the options for player two can be represented as 1,2,3,..,n. If player 1 selects alternative i and player 2 selects alternative j then the payoff can be written as e_{ij} . The table of payoffs is as follows:

		Alternatives for player 1				
		1	2	3	...	n
Alternative for player 2	1	a_{11}	a_{12}	a_{13}	...	a_{1n}
	2	a_{21}	a_{22}	a_{23}	...	a_{2n}
	3	a_{31}	a_{32}	a_{33}	...	a_{3n}
	.					
	.					
	m	a_{m1}	a_{m2}	a_{m3}	...	a_{mn}

A saddle point solution is obtained if the maximum of the minimum of rows equals the minimum of the maximum of columns i.e $\max_i(\min_j a_{ij}) = \min_j(\max_i a_{ij})$
i.e $\max(\min a_{ij}) = \min(\max a_{ij})$

Example 1

Investigate if a saddle point solution exists in this matrix

$$\begin{bmatrix} 2 & 1 & -4 \\ -3 & 6 & 2 \end{bmatrix}$$

Solution

$$\begin{matrix} & \min & & \\ \begin{bmatrix} 2 & 1 & 1 & -4 \\ -3 & 6 & 2 & -3 \end{bmatrix} & & & \end{matrix}$$

Max $\begin{matrix} 2 & 6 & 3 \end{matrix}$

$\max_i(\min_j a_{ij}) = \max(-4, -3) = -3$
 $\min_j(\max_i a_{ij}) = \min(2, 6, 3) = 2$
 $\max_i(\min_j a_{ij}) \neq \min_j(\max_i a_{ij})$
So a saddle point solution does not exist.

Example 2

We shall consider a game called the “matching penny” game which is usually played by children. In this game two players agree that one will be even and the other odd. Each

one then shows a penny. The pennies are shown simultaneously and each child shows a head or tail. If both show the same side “even” wins the penny from odd and if they show different sides odd wins from even. Draw the matrix of payoffs

Solution

The pay-off table is as follows:

		Odd	(Player 2)
		Head	Tail
Head]	(1,-1)	(-1, 1)
Even Tail		(-1, 1)	(1,-1)

(Player 1)

The sum in each cell is zero, hence it is a zero sum game. Now A (H, T), B (H, T) and y (H,H)= y(T,T) 1 while y (H,T)=(T,H)=-1, In matrix form, if row is for even and column is for odd we have the matrix of payoffs given to player I by players 2 as

$$\begin{bmatrix} 1 & -1 \\ -1 & 1 \end{bmatrix}$$

SOLUTION OF TWO-PERSON ZERO-SUM GAMES

Every two-person zero-sum game has a solution given by the value of the game together with the optimal strategies employed by each of the two players in the game. The strategies employed in a two person zero sum game could be

- i. Pure Strategies
- ii. Dominating Strategies
- iii. Mixed Strategies

Example 3

Find the solutions of this matrix game

$$\begin{bmatrix} -200 & -100 & -40 \\ 400 & 0 & 300 \\ 300 & -20 & 400 \end{bmatrix}$$

Solution

We check if $\max (\min a_{ij}) \min (\max a_{ij})$ in order to know whether it has a saddle point solution. We first find the minimum of rows and maximum of columns as follows.

$$\begin{pmatrix} -200 & -100 & -40 \\ 400 & 0 & 300 \\ 300 & -20 & 400 \end{pmatrix} \begin{matrix} -200 \\ -20 \end{matrix}$$

$$\text{Max} \quad 400 \quad 0 \quad 400$$

So $\max_i (\min_j a_{ij}) = \max (-200, 0, -20) = 0$

$\min(\max_j a_{ij}) = \min (400, 0, 400)$. So a saddle point solution exists at (row2, column2)

i.e. (r_2, c_2) The value of the game is 0.

3.5.2 DOMINATING STRATEGIES

In a pay-off matrix row dominance of i over j occurs if $a_i > a_j$, while column dominance of i over j occurs if $b_i < b_j$. If dominance occurs, column j is not considered and we reduce the matrix by dominance until we are left with a 1×1 matrix whose saddle point solution can be easily found. We consider the matrix

$$\begin{pmatrix} 3 & 4 & 5 & 3 \\ 3 & 1 & 2 & 3 \\ 1 & 3 & 4 & 4 \end{pmatrix}$$

Observation shows that every element in column 1 is less than or equal to that of column 4 and we may remove column 4 the dominating column. Similarly b_3 dominates b_2 and we remove the dominating column b_3 . The game is reduced to

$$\begin{pmatrix} 3 & 4 \\ 3 & 1 \\ 1 & 3 \end{pmatrix}$$

In row dominance, we eliminate the dominated rows a_i (where $a_i > a_j$) while in column dominance we eliminate the dominating column b_j (where $b_i < b_j$) since player 2 desired to concede the least payoff to the row player and thus minimise his losses.

This procedure is iterated using row dominance. Since a_1 dominates a_2 and also dominates a_3 we remove the dominated rows a_2 and a_3 . This is due to the fact that player 1, the row player, wishes to maximise his payoffs. We then have a 1×1 reduced game [3 4] which has a saddle point solution. Generally if a dominated strategy is reduced for a game, the solution of the reduced game is the solution of the original game.

3.5.3 MIXED STRATEGIES

Suppose the matrix of a game is given by

$$A = \begin{pmatrix} 2 & -1 & 3 \\ -1 & 3 & -2 \end{pmatrix}$$

Inspection shows that i column dominance cannot be used to obtain a saddle point solution. If no saddle point solution exists we randomise the strategies. Random choice of strategies is the main idea behind a mixed strategy. Generally a mixed strategy for player is defined as a probability distribution on the set of pure strategies. The minimax theorem put forward by von Neumann enables one to find the optimal strategies and value of a game that has no saddle point solution and he was able to show that every two-person zero-sum game has a solution in mixed if not in pure strategy.

3.5.4 OPTIMAL STRATEGIES IN 2 X 2 MATRIX GAME

Linear optimisation in linear programming enables one to calculate the value and optimal actions especially when the elements of A are more than 2. We now demonstrate how to solve the matching pennies matrix with a simple method applicable when A has two elements and B is finite. Here the value is given as $\max_{\theta} \min_{\phi} (\theta \phi [a_1, b_1] + (1-\theta) \phi (a_2, b_2))$

The matrix is

$$\begin{matrix} & \theta_1 & 1-\theta_1 \\ \theta_1 & \begin{bmatrix} -1 & 1 \end{bmatrix} \\ & 1-\theta_1 & \begin{bmatrix} 1 & -1 \end{bmatrix} \end{matrix}$$

We note here that the maximin criterion cannot hold since $\max(\min \text{ of row}) = \max(-1, -1) = -1$ while $\min(\max \text{ of columns}) = \min(1, 1) = 1$ and no saddle point solution exists.

Let "even" choose randomised action $(\theta, 1-\theta)$ i.e $\theta = a_1$ and $(1-\theta) = a_2$. Using formula above, we have $\max_{\theta} \min_{\phi} (\theta \phi [a_1, b_1] + (1-\theta) \phi (a_2, b_2))$

$\theta + -1(1-\theta) = -\theta + 1(1-\theta)$ using principle of equalising expectations.

This gives $2\theta - 1, 1 - 2\theta$

$4\theta = 2$. And $\theta = 1/2$

Similarly if optimal randomised action by player 2 = θ_1 ,

then we get $\theta_1 + (1-\theta_1) - 1, \theta_1 + 1 - \theta_1$

$\theta_1(1) + -1(1 - \theta_1) = \theta_1(-1) + (1 - \theta_1)$. Simplify both sides of the equation to get $2\theta_1 - 1 = 1 - 2\theta_1$ and so randomised action by player 1 is $(\frac{1}{2}, \frac{1}{2})$ and also $(\frac{1}{2}, \frac{1}{2})$ by player 1

The value can be obtained by substituting $\theta_1 = \frac{1}{2}$ into $2\theta - 1$ or $1 - 2\theta$ or by substituting $\theta_1 = \frac{1}{2}$ into $2\theta_1 - 1$ or $1 - 2\theta_1$. If we do this we get a value of zero. So the solution is as follows: Optimal strategies of $(\frac{1}{2}, \frac{1}{2})$ for player 1 and $(\frac{1}{2}, \frac{1}{2})$ for player 2 and the value of the game is 0.

It is Obvious that there is no optimal mixed strategy that is independent of the opponent.

Example 4

Two competing telecommunication companies MTN and Airtel both have objective of maintaining large share in the telecommunication industry. They wish to take a decision concerning investment in a new promotional campaign. Airtel wishes to consider the following options:

- r_1 : advertise on the Internet
- r_2 : advertise in all mass media

MTN wishes to consider these alternatives

- c_1 : advertise in newspapers only
- c_2 : run a big promo

If Airtel advertise on the Internet and MTN advertises in newspapers, MTN will increase its market share by 3% at the expense of V-Mobile. If MTN runs a big promo and Airtel advertises on the Internet, Airtel will lose 2% of the market share. If Airtel advertises in mass media only and MTN advertises in newspapers, Airtel will lose 4%. However, if Airtel advertises in mass media only and MTN runs a big promo, Airtel will gain 5% of the market share.

- a) Arrange this information on a payoff table
- b) What is the best policy that each of the two companies should take?

Solution

- a) The matrix of payoff is as follows

MTN		
	c_1	c_2
Airtel	r_1	$\begin{bmatrix} 3 & -2 \\ -4 & 5 \end{bmatrix}$

We first check if a saddle point solution exists. We use the minimax criterion to do this. Now for the rows, Minimax (3,5) = 3 while for the columns Maximin = Max (-4, -2) = -2.

Since minimax is not equal to maximin, no saddle point solution exists. We then randomise and use the mixed strategy.

Let $(\theta, 1 - \theta)$ be the mixed strategies adopted by Airtel while $(\theta_1, 1 - \theta_1)$ be the strategies adopted by MTN

Then for Airtel. $\theta(3) + 4(1 - \theta) - 2\theta + 5(1 - \theta)$

$$3\theta - 4 + 4\theta = -2\theta + 5 - 5\theta$$

$$7\theta - 4 = -7\theta + 5.$$

Solving we obtain

$$\theta = \frac{9}{14} \text{ and } 1 - \theta = \frac{5}{14}$$

The randomised strategies by V-Mobile will be $(\frac{9}{14})$

For MTN, $3\theta - 2(1 - \theta) = -4\theta_1 + 5(1 - \theta_1)$

$$3\theta + 2\theta_1 - 2 = -4\theta_1 + 5 - 5\theta_1$$

$$5\theta_1 - 2 = -9\theta_1 + 5. \text{ Solving, we obtain } \theta_1 = \frac{1}{2} \text{ and } 1 - \theta_1 = \frac{1}{2}$$

The value of the game can be found by substituting $\frac{9}{14}$ into $7\theta - 4$ or $-7\theta + 5$; or $\frac{1}{2}$ into $5\theta - 2$ or $-9\theta + 5$. When we do this we obtain the value $\frac{1}{2}$. So Airtel should advertise on the Internet $\frac{9}{14}$ of the time and advertise on the mass media $\frac{5}{14}$ of the time. On the other hand, MTN should advertise in the newspapers only 50% ($\frac{1}{2}$) of the time and run a big promo $\frac{1}{2}$ of the time. The expected gain of Airtel is $\frac{1}{2}$ of the market share.

3.5.5 EQUILIBRIUM PAIRS

In mixed strategies, a pair of optimal strategies a^* and b^* is in equilibrium if for any other a and b , $E(a, b^*) \leq E(a^*, b^*) \leq E(a^*, b)$

A pair of strategies (a^*, b^*) in a two person zero sum game is in equilibrium if and only if $\{(a^*, b^*), E(a^*, b^*)\}$ is a solution to the game. Nash Theory states that any two person game (whether zero-sum or non-zero-sum) with a finite number of pure strategies has at least one equilibrium pair. No player can do better by changing strategies, given that the other players continue to follow the equilibrium strategy.

3.5.6 OPTIMAL STRATEGIES IN 2 X N MATRIX GAME

Suppose we have a matrix game of

$$\begin{pmatrix} 5 & 2 & 4 \\ 3 & 4 & 5 \end{pmatrix}$$

Now

$$\max_i (\min_j a_{ij}) = \max(2, 3) = 3 \text{ while } = \min(\max) 4.$$

The two players now have to look for ways of assuring themselves of the largest possible shares of the difference

$$\max_i (\min_j a_{ij}) - \min_i (\max_j a_{ij}) \geq 0$$

They will therefore need to select strategies randomly to confuse each other. When a player chooses any two or more strategies at random according to specific probabilities this device is known as a mixed strategy.

There are various methods employed in solving 2x2, 2xn, mx2 and m x n game matrix and hence finding optimal strategies as we shall discuss in this and the next few sections. Suppose the matrix of game is m x n. If player one is allowed to select strategy I with probability p_i and player two strategy II with probability q_j . then we can say player 1 uses strategy

$$P=(P_1, P_2 \dots P_m)$$

While player 2 selects strategy

$$q=(q_1, q_2, \dots q_n).$$

The expected payoffs for player 1 by player two can be explained in

$$E_{\sigma} \sigma^* = \sum_{i=1}^m \sum_{j=1}^n p_i q_j a_{ij}$$

In this game the row player has strategy $q = (q_1, q_2, \dots, q_n)$. The max-min reasoning is used to find the optimal strategies to be employed by both player. We demonstrate with a practical example:

Example 5

Let the matrix game be

$$\begin{bmatrix} 5 & 2 & 4 \\ 3 & 4 & 5 \end{bmatrix}$$

Solution

Inspection shows that this does not have a saddle point solution. The optimal strategy p^* for the row player is the one that will give him the maximum pay-off. Since $p = (p_1, p_2)$. Let the expected value of the row be represented by $E_{1(p)}$. If player 2 plays column 1 is =

$$5p + 3(1-p) = 2p + 3$$

If player 2 plays column 2 we have

$$E_{2(p)} = 2p + 4(1-p) = -2p + 4$$

and if player 2 plays column 3 we have

$$E_{3(p)} = 4p + 5(1-p) = p + 5. \text{ So, } E_{1(p)} = 2p + 3; E_{2(p)} = -2p + 4 \text{ and } E_{3(p)} = p + 5$$

are the payoffs for player 1 against the three part strategies of player 2, we give arbitrary values for p to check which of these strategies by player2 will yield the largest payoff for

player 1.

$$\text{Let } p^{3/4} \dots\dots\dots E_1 = -2x^{3/4} + 3 = 4^{1/2}$$

$$E_{2(p)} = 2x^{1/4} + 4 = 2^{1/2} \quad E_{2(p)} = -^{3/4} + 5 = 4^{1/4}.$$

So the two largest are $E_{1(p)}$, $E_{3(p)}$ and we equate them to get

$$2p = 3 = p + 5$$

so $3p = 2, p = 2/3$

$$E_{j(p)} = (2 \times 2/3) + 3 = 4^{1/3}$$

$$E = -2_{(p)} - 2 \times 2^{2/3} + 4 = 2^{2/3} \text{ and } E_{3(p)} = 2/3 + 5 = 74^{1/3}$$

So $(2/3, 1/3)$ is optimal for player 1. To get the optimal strategy for player 2, we observe that it is advisable for player 2 to play column 2 in order to ensure that the payoff to row player is minimal. So the game is reduced to

$$\begin{pmatrix} 5 & 4 \\ 3 & 5 \end{pmatrix}$$

Let $(q, 1-q)$ be the strategy for player 2 in a required game.

$$\text{So } 5q + 4(1-q) \quad 3q + 5(1-q)$$

$$5q + 4 - 4q = 3q + 5 - 5q$$

$$q + 4 = 5 - 2q$$

$$3q = 1 \quad q = 1/3$$

So it is optimal for player 2 to play mixed strategy with probability $q(1/3, 0, 2/3)$. If we substitute $q = 1/3$ into $q + 4$ or $5 - 2q$, we obtain $4^{1/3}$ as before. This is the value of the game.

4.0 CONCLUSION

The above analysis shows that number system is the foundation of any mathematical analysis. It cut across all discipline, it is used daily by every individual in daily life be it in the home, office, or business. It is very essential to know the basics of numbers as a means of evaluation of any transaction; this is because numbers help us to measure quantity, price and other variables of life.

5.0 SUMMARY

For child or adult, man or woman, government official or business executive, worker or supervisor, participation in the process of decision-making is a common feature of everyday life. A competitive situation is called a game if it has the following characteristics- there is finite number of competitors called Players. A list of finite or infinite number of possible courses of action is available to each player; a list of finite or infinite number of possible courses of action is available to each player; a play is played

when each player chooses one of his courses of actions; all players act rationally and intelligently. Each player is interested in maximizing his gains or minimizing his losses; each player makes individual decisions without direct communication between the players; it is assumed that each player knows complete relevant information.

6.0 TUTOR MARKED ASSIGNMENT

1. What do you understand by a game?

2. Write short notes on the following

- Player
- Moves
- Game
- Decision maker
- Objective
- Behaviour

3. Find the optimal strategies for the matrix game

$$X = \begin{matrix} & & \begin{matrix} -2 & 2 \\ -2 & 3 \end{matrix} \\ \begin{matrix} 3 & -2 \end{matrix} & & \end{matrix}$$

7.0 REFERENCES

Adebayo, O.A., Ojo, O., and Obamire, J. K. (2006). Operations Research in Decision Analysis, Lagos: Pumarck Nigeria Limited.

Murthy, R. P. (2007). Operations Research, 2nd ed., New Delhi: New Age International (P) Limited Publishers

UNIT 3: INVENTORY CONTROL

- 1.0 Introduction
- 2.0 Objective
- 3.0 Main Content
 - 3.1 Definition of Inventory and Inventory Control
 - 3.2 Basic Concepts in Inventory Planning
 - 3.3 Necessity for Maintaining Inventory
 - 3.4 Causes of Poor Inventory Control Systems
 - 3.5 Classification of Inventories
 - 3.6 Costs Associated With Inventory
 - 3.7 Purpose of Maintaining Inventory or Objective of Inventory cost Control
 - 3.8 Other Factors to be considered in Inventory Control
 - 3.9 Inventory Control Problem
 - 3.10 The Classical EOQ Model (Demand Rate Uniform, Replenishment Rate Infinite)
- 4.0 Conclusion
- 5.0 Summary
- 6.0 Tutor Marked Assignment
- 7.0 References

1.0 INTRODUCTION

One of the basic functions of management is to employ capital efficiently so as to yield the maximum returns. This can be done in either of two ways or by both, *i.e.* (a) By maximizing the margin of profit; or (b) By maximizing the production with a given amount of capital, *i.e.* to increase the productivity of capital. This means that the management should try to make its capital work hard as possible. However, this is all too often neglected and much time and ingenuity are devoted to make only labour work harder. In the process, the capital turnover and hence the productivity of capital is often totally neglected.

Inventory management or Inventory Control is one of the techniques of Materials Management which helps the management to improve the productivity of capital by reducing the material costs, preventing the large amounts of capital being locked up for long periods, and improving the capital - turnover ratio. The techniques of inventory control were evolved and developed during and after the Second World War and have helped the more industrially developed countries to make spectacular progress in improving their productivity.

2.0 OBJECTIVES

At the this study unit, you should be able to

- 1 Define inventory control
- 2 Explain the basic concepts in inventory control

- 3 Identify the issues that necessitate maintaining inventory
- 4 Identify causes of poor inventory control systems
- 5 Discuss the various classifications of inventories

3.0 MAIN CONTENT

3.1 DEFINITION OF INVENTORY AND INVENTORY CONTROL

The word *inventory* means a physical stock of material or goods or commodities or other economic resources that are stored or reserved or kept in stock or in hand for smooth and efficient running of future affairs of an organization at the minimum cost of funds or capital blocked in the form of materials or goods (Inventories). The function of directing the movement of goods through the entire manufacturing cycle from the requisitioning of raw materials to the inventory of finished goods in an orderly manner to meet the objectives of maximum customer service with minimum investment and efficient (low cost) plant operation is termed as *inventory control*. (Murthy, 2007)

Gupta and Hira (2012) defined an inventory as consisting of usable but idle resources such as men, machines, materials, or money. When the resources involved are material, the inventory is called stock. An inventory problem is said to exist if either the resources are subject to control or if there is at least one such cost that decrease as inventory increases. The objective is to minimise total (actual or expected) cost. However, in situations where inventory affects demand, the objective may also be to minimise profit.

3.2 BASIC CONCEPTS IN INVENTORY PLANNING

For many organizations, inventories represent a major capital cost, in some cases the dominant cost, so that the management of this capital becomes of the utmost importance. When considering the inventories, we need to distinguish different classes of items that are kept in stock. In practice, it turns out that about 10% of the items that are kept in stock usually account for something in the order of 60% of the value of all inventories. Such items are therefore of prime concern to the company, and the stock of these items will need close attention. These most important items are usually referred to as “A items” in the ABC classification system developed by the General Electric Company in the 1950s. The items next in line are the B items, which are of intermediate importance. They typically represent 30% of the items, corresponding to about 30% of the total inventory value. Clearly, B items do require some attention, but obviously less than A items. Finally, the bottom 60% of the items are the C items. They usually represent maybe 10% of the monetary value of the total inventory. The control of C items in inventory planning is less crucial than that of the A and B items. The models in this chapter are mostly aimed at A items.

3.3 NECESSITY FOR MAINTAINING INVENTORY

Though inventory of materials is an idle resource (since materials lie idle and are not to be used immediately), almost every organisation. Without it, no business activity can be performed, whether it is service organisation like a hospital or a bank or it a manufacturing or trading organisation. Gupta and Hira (2012) present the following reasons for maintain inventories in organisations.

1. It helps in the smooth and efficient of an enterprise.
2. It helps in providing service to the customer at short notice.
3. In the absence of inventory, the enterprise may have to pay high prices due to piecemeal purchasing.
4. It reduces product cost since there is an added advantage of batching and long, uninterrupted production runs.
5. It acts as a buffer stock when raw materials are received late and shop rejection is too many.

3.4 CAUSES OF POOR INVENTORY CONTROL SYSTEMS

- a. Overbuying without regard to the forecast or proper estimate of demand to take advantages of favourable market.
- b. Overproduction or production of goods much before the customer requires them
- c. Overstocking may also result from the desire to provide better service to the custom.
- d. Cancellation of orders and minimum quantity stipulations by the suppliers may also give rise to large inventories.
(Gupta and Hira, 2012)

3.5 CLASSIFICATION OF INVENTORIES

Inventories may be classified as those which play direct role during manufacture or which can be identified on the product and the second one are those which are required for manufacturing but not as a part of production or cannot be identified on the product. The first type is labelled as *direct inventories* and the second are labelled as *indirect inventories*. Further classification of direct and indirect inventories is as follows:

A. Direct inventories

(i) **Raw material inventories or Production Inventories:** The inventory of raw materials is the materials used in the manufacture of product and can be identified on the product. In inventory control manager can concentrate on the

- (a) Bulk purchase of materials to save the investment,
- (b) To meet the changes in production rate,
- (c) To plan for buffer stock or safety stock to serve against the delay in delivery of inventory against orders placed and also against seasonal fluctuations. Direct inventories include the following:

- **Production Inventories-** items such as raw materials, components and subassemblies used to produce the final products.
- **Work-in-progress Inventory-** items in semi-finished form or products at different stages of production.
- **Miscellaneous Inventory-** all other items such as scrap, obsolete and unsaleable products, stationary and other items used in office, factory and sales department, etc.

(ii) Work-in -process inventories or in process inventories: These inventories are of semi-finished type, which are accumulated between operations or facilities. As far as possible, holding of materials between operations to be minimized if not avoided. This is because; as we process the materials the economic value (added labour cost) and use value are added to the raw material, which is drawn from stores. Hence if we hold these semi-finished material for a

long time the inventory carrying cost goes on increasing, which is not advisable in inventory control. These inventories serve the following purposes:

- (a) Provide economical lot production,
- (b) Cater to the variety of products,
- (c) Replacement of wastages,
- (d) To maintain uniform production even if sales varies.

(iii) Finished goods inventories: After finishing the production process and packing, the finished products are stocked in stock room. These are known as finished goods inventory. These are maintained to:

- (a) To ensure the adequate supply to the customers,
- (b) To allow stabilization of the production level and
- (c) To help sales promotion programme.

(iv) MRO Inventory or Spare parts inventories: Maintenance, Repair, and Operation items such as spare parts and consumable stores that do not go into final products but are consumed during the production process. Any product sold to the customer, will be subjected to wear and tear due to usage and the customer has to replace the worn-out part. Hence the manufacturers always calculate the life of the various components of his product and try to supply the spare components to the market to help after sales service. The use of such spare parts inventory is:

- (a) To provide after sales service to the customer,
- (b) To utilize the product fully and economically by the customer.

(iv) Scrap or waste inventory or Miscellaneous Inventory: While processing the materials, we may come across certain wastages and certain bad components (scrap), which are of no use. These may be used by some other industries as raw material. These are to be collected and kept in a place away from main stores and are disposed periodically by auctioning.

B. Indirect Inventories

Inventories or materials like oils, grease, lubricants, cotton waste and such other materials are required during the production process. But we cannot identify them on the product. These are known as indirect inventories. In our discussion of inventories, in this chapter, we only discuss about the direct inventories. Inventories may also be classified depending on their nature of use. They are:

(i) Fluctuation Inventories: These inventories are carried out to safeguard the fluctuation in demand, non-delivery of material in time due to extended lead-time. These are sometimes called as Safety stock or reserves. In real world inventory situations, the material may not be received in time as expected due to trouble in transport system or some times, the demand for a certain material may increase unexpectedly. To safeguard such situations, safety stocks are maintained. The level of this stock will fluctuate depending on the demand and lead-time etc.

(ii) Anticipation inventory: When there is an indication that the demand for company's product is going to be increased in the coming season, a large stock of material is stored in anticipation. Some times in anticipation of raising prices, the material is stocked. Such inventories, which are stocked in anticipation of raising demand or raising rises, are known as anticipation inventories.

(iii) Lot size inventory or Cycle inventories: This situation happens in batch production system. In this system products are produced in economic batch quantities. It sometime happens that the materials are procured in quantities larger than the economic quantities to meet the fluctuation in demand. In such cases the excess materials are stocked, which are known as lot size or cycle inventories.

3.6 COSTS ASSOCIATED WITH INVENTORY

While maintaining the inventories, we will come across certain costs associated with inventory, which are known as *economic parameters*. Most important of them are discussed below:

A. Inventory Carrying Charges, or Inventory Carrying Cost or Holding Cost or Storage Cost (C_1) or ($i\%$)

This cost arises due to holding of stock of material in stock. This cost includes the cost of maintaining the inventory and is proportional to the quantity of material held in stock and the time for which the material is maintained in stock. The components of inventory carrying cost are:

- i. Rent for the building in which the stock is maintained if it is a rented building. In case it is own building, depreciation cost of the building is taken into consideration. Sometimes for own buildings, the nominal rent is calculated depending on the local rate of rent and is taken into consideration.
- ii. It includes the cost of equipment if any and cost of racks and any special facilities used in the stores.

- iii. Interest on the money locked in the form of inventory or on the money invested in purchasing the inventory.
- iv. The cost of stationery used for maintaining the inventory.
- v. The wages of personnel working in the stores.
- vi. Cost of depreciation, insurance.

B. Shortage cost or Stock - out - cost- (C_2)

Sometimes it so happens that the material may not be available when needed or when the demand arises. In such cases the production has to be stopped until the procurement of the material, which may lead to miss the delivery dates or delayed production. When the organization could not meet the delivery promises, it has to pay penalty to the customer. If the situation of stock out will occur very often, then the customer may not come to the organization to place orders that is the organization is losing the customers. In other words, the organization is losing the goodwill of the customers. The cost of goodwill cannot be estimated. In some cases it will be very heavy to such extent that the organization has to forego its business. Here to avoid the stock out situation, if the organization stocks more material, inventory carrying cost increases and to take care of inventory cost, if the organization purchases just sufficient or less quantity, then the stock out position may arise. Hence the inventory manager must have sound knowledge of various factors that are related to inventory carrying cost and stock out cost and estimate the quantity of material to be purchased or else he must have effective strategies to face grave situations. The cost is generally represented as so many naira and is represented by C_2 .

C. Set up cost or Ordering cost or Replenishment Cost (C_3)

For purchase models, the cost is termed as ordering cost or procurement cost and for manufacturing cost it is termed as set up cost and is represented by C_3 .

(i) Set up cost: The term set up cost is used for production or manufacturing models. Whenever a job is to be produced, the machine is to be set to produce the job. That is the tool is to be set and the material is to be fixed in the jobholder. This consumes some time. During this time the machine will be idle and the labour is working. The cost of idle machine and cost of labour charges are to be added to the cost of production. If we produce only one job in one set up, the entire set up cost is to be charged to one job only. In case we produce ' n ' number of jobs in one set up, the set up cost is shared by ' n ' jobs. In case of certain machines like N.C machines, or Jig boarding machine, the set up time may be 15 to 20 hours. The idle cost of the machine and labour charges may work out to few thousands of naira. Once the machine set up is over, the entire production can be

completed in few hours if we produce more number of products in one set up the set up cost is allocated to all the jobs equally. This reduces the production cost of the product. For example let us assume that the set up cost is N 1000/-. If we produce 10 jobs in one set up, each job is charged with ₹ 100/- towards the set up cost. In case, if we produce 100 jobs, the set up cost per job will be ₹10/-. If we produce, 1000 jobs in one set up, the set up cost per job will be Re. 1/- only. This can be shown by means of a graph as shown in figure 15.1.

(ii) Ordering Cost or Replenishment Cost: The term Ordering cost or Replenishment cost is used in purchase models. Whenever any material is to be procured by an organization, it has to place an order with the supplier. The cost of stationary used for placing the order, the cost of salary of officials involved in preparing the order and the postal expenses and after placing the order enquiry charges all put together, is known as ordering cost. In Small Scale Units, this may be around ₹ 25/- to ₹ 30/- per order. In Larger Scale Industries, it will be around ₹ 150 to N 200 /- per order. In Government organizations, it may work out to ₹ 500/- and above per order. If the organization purchases more items per order, all the items share the ordering cost. Hence the materials manager must decide how much to purchase per order so as to keep the ordering cost per item at minimum. One point we have to remember here, to reduce the ordering cost per item, if we purchase more items, the inventory carrying cost increases. To keep inventory carrying cost under control, if we purchase less quantity, the ordering cost increase. Hence one must be careful enough to decide how much to purchase? The nature of ordering cost can also be shown by a graph as shown in figure 8.1. If the ordering cost is C_3 per order (can be equally applied to set up cost) and the quantity ordered / produced is 'q' then the ordering cost or set up cost per unit will be C_3/q is inversely proportional to the quantity ordered, *i.e.* decreased with the increase in 'q' as shown in the graph below.

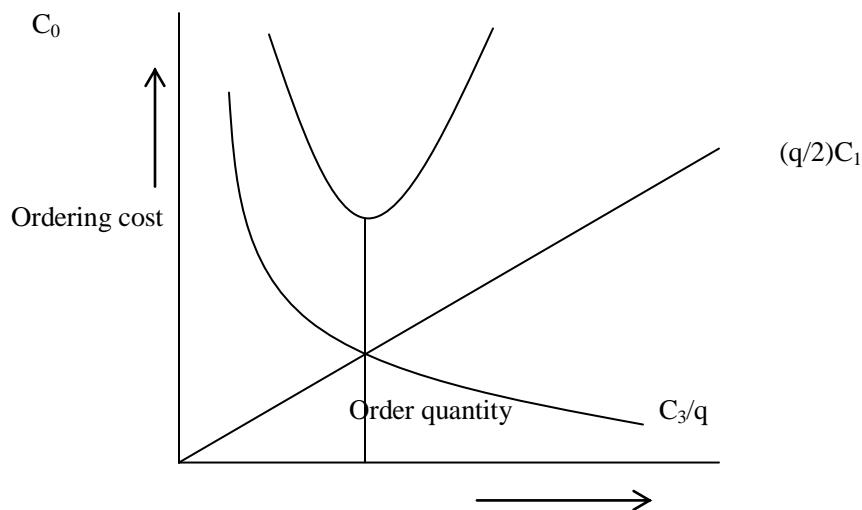

Fig. 15.1: Ordering Cost

Source : Murthy, P. R. (2007) *Operations Research 2nd ed.* New Delhi: New Age International Publishers

(iii) Procurement Cost: These costs are very much similar to the ordering cost / set up cost. This cost includes cost of inspection of materials, cost of returning the low quality materials, transportation cost from the source of material to the purchaser's site. This is proportional to the quantity of materials involved. This cost is generally represented by 'b' and is expressed as so many naira per unit of material. For convenience, it always taken as a part of ordering cost and many a time it is included in the ordering cost / set up cost.

D. Purchase price or direct production cost

This is the actual purchase price of the material or the direct production cost of the product. It is represented by 'p'. *i.e.* the cost of material is ₦ 'p' per unit. This may be constant or variable. Say for example the cost of an item is N 10/- item if we purchase 1 to 10 units. In case we purchase more than 10 units, 10 percent discount is allowed. *i.e.* the cost of item will be ₦9/- per unit. The purchase manager can take advantage of discount allowed by purchasing more. But this will increase the inventory carrying charges. As we are purchasing more per order, ordering cost is reduced and because of discount, material cost is reduced. Materials manager has to take into consideration these cost – quantity relationship and decide how much to purchase to keep the inventory cost at low level.

3.7 PURPOSE OF MAINTAINING INVENTORY OR OBJECTIVE OF INVENTORY COST CONTROL

The purpose of maintaining the inventory or controlling the cost of inventory is to use the available capital optimally (efficiently) so that inventory cost per item of material will be as small as possible. For this the materials manager has to strike a balance between the interrelated inventory costs. In the process of balancing the interrelated costs *i.e.* Inventory carrying cost, ordering cost or set up cost, stock out cost and the actual material cost. Hence we can say that *the objective of controlling the inventories is to enable the materials manager to place and order at right time with the right source at right price to purchase right quantity.* The benefits derived from efficient inventory control are:

- i. It ensures adequate supply of goods to the customer or adequate of quantity of raw materials to the manufacturing department so that the situation of stock out may be reduced or avoided.
- ii. By proper inventory cost control, the available capital may be used efficiently or optimally, by avoiding the unnecessary expenditure on inventory.
- iii. In production models, while estimating the cost of the product the material cost is to be added. The manager has to decide whether he has to take the actual purchase price of the material or the current market price of the material. The current market price may be less than or greater than the purchase price of the material which has been purchased some period back. Proper inventory control reduces such risks.

iv. It ensures smooth and efficient running of an organization and provides safety against late delivery times to the customer due to uncontrollable factors

v. A careful materials manager may take advantage of price discounts and make bulk purchase at the same time he can keep the inventory cost at minimum.

3.8 OTHER FACTORS TO BE CONSIDERED IN INVENTORY CONTROL

There are many factors, which have influence on the inventory, which draws the attention of an inventory manager, they are:

(i) Demand

The demand for raw material or components for production or demand of goods to satisfy the needs of the customer, can be assessed from the past consumption/supply pattern of material or goods. We find that the demand may be deterministic in nature *i.e.*, we can specify that the demand for the item is so many units for example say ' q ' units per unit of time. Also the demand may be static, *i.e.* it means constant for each time period (uniform over equal period of times).

The supply of inventory to the stock may deterministic or probabilistic (stochastic) in nature and many a times it is uncontrollable, because, the rate of production depends on the production, which is once again depends on so many factors which are uncontrollable / controllable factors Similarly supply of inventory depends on the type of supplier, mode of supply, mode of transformation etc.

(iii) Lead time or Delivery Lags or Procurement time

Lead-time is the time between placing the order and receipt of material to the stock. In production models, it is the time between the decisions made to take up the order and starting of production. This time in purchase models depends on many uncontrollable factors like transport mode, transport route, agitations etc. It may vary from few days to few months depending on the nature of delay.

(iv) Type of goods

The inventory items may be discrete or continuous. Sometimes the discrete items are to be considered as continuous items for the sake of convenience.

(v) Time horizon

The time period for which the optimal policy is to be formulated or the inventory cost is to be optimized is generally termed as the Inventory planning period of Time horizon. This time is represented on X - axis while drawing graphs. This time may be finite or infinite.

In any inventory model, we try to seek answers for the following questions:

(a) When should the inventory be purchased for replenishment? For example, the inventory should be replenished after a period 't' or when the level of the inventory is q_0 .

(b) How much quantity must be purchased or ordered or produced at the time of replenishment so as to minimize the inventory costs? For example, the inventory must be purchased with the supplier who is supplying at a cost of $Np/-$ per unit. In addition to the above depending on the data available, we can also decide from which source we have to purchase and what price we have to purchase? But in general time and quantity are the two variables, we can control separately or in combination.

3.9 INVENTORY CONTROL PROBLEM

The inventory control problem consists of the determination of three basic factors:

1. When to order (produce or purchase)?
2. How much to order?
3. How much safety stock to be kept?

When to order: This is related to lead time (also called delivery lag) of an item. Lead time may interval between the placement of an order for an item and its receipt in stock. It may be replenishment order on an outside or within the firm. There should be enough stock for each item so that customers' orders can be reasonably met from this stock until replenishment.

How much to order: Each order has an associated ordering cost or cost of acquisition. To keep this cost low, the number of orders has to be as reduced as possible. To achieve limited number of orders, the order size has to be increased. But large order size would imply high inventory cost.

How much should the safety stock be. This is important to avoid overstocking while ensuring that no stock out takes place.

The inventory control policy of an organisation depends upon the demand characteristics. The demand for an item may be dependent or independent. For instance, the demand for the different models of television sets manufactured by a company does not depend upon the demand for any other item, while the demand for its components will depend upon the demand for the television sets.

3.10 THE CLASSICAL EOQ MODEL (Demand Rate Uniform, Replenishment Rate Infinite)

According Gupta and Hira 2012, the EOQ model is one of the simplest inventory models we have. A store keeper has an order to supply goods to customers at a uniform rate R per unit. Hence, the demand is fixed and known. Not shortages are allowed, consequently, the cost of shortage C_2 is infinity. The store keeper places an order with a manufacturer every t time units, where t is fixed; and the ordering cost per order is C_3 .

Replenishment time is negligible, that is, replenishment rate is infinite so that the replacement is instantaneous (lead time is zero). The holding cost is assumed to be proportional to the amount of inventory as well as the time inventory is held. Hence the time of holding inventory I for time T is C_1IT , where C_1 , C_2 and C_3 are assumed to be constants. The store keeper's problem is therefore to the following

- i. How frequently should he place the order?
- ii. How many units should he order in each order placed?

This model is represented schematically below.

If orders are placed at intervals t , a quantity $q = Rt$ must be ordered in each order. Since the stock in small time dt is $Rtdt$ the stock in time period t will be

$$\int_0^t Rt \cdot dt = \frac{1}{2} Rt^2 = \frac{1}{2} qt = \text{Area of inventory triangle OAP.}$$

Inventory Graph for the Basic Inventory Control Model

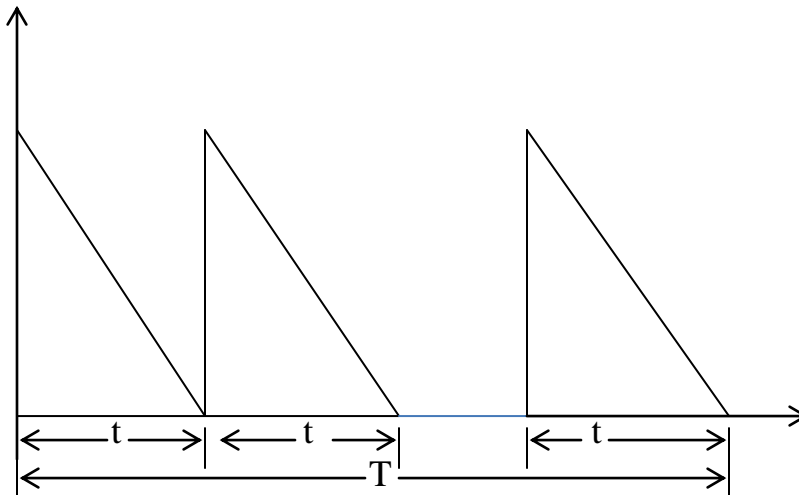

Fig. Inventory situation for EOQ model

$$\therefore \text{Cost of holding inventory during time } t = \frac{1}{2} C_1 R t^2.$$

Order cost to place an order = C_3 .

$$\therefore \text{Total cost during time } t = \frac{1}{2} C_1 R t^2 + C_3.$$

$$\therefore \text{Average total cost per unit, } C(t) = \frac{1}{2} C_1 R t + \frac{C_3}{t} \dots \dots \dots (1)$$

C will be minimum if $\frac{dC(t)}{dt} = 0$ and $\frac{d^2C(t)}{dt^2}$ is positive.

Differentiating equation (1) w.r.t 't'

$$\frac{d^2C(t)}{dt^2} = \frac{1}{2} C_1 R - \frac{C_3}{t^2} = 0, \text{ which gives } t = \sqrt{\frac{2C_3}{C_1 R}}$$

Differentiating w.r.t. 't'

$$\frac{d^2C(t)}{dt^2} = \frac{2C_3}{t^3} \text{ which is positive for value of } t \text{ given by the above equation.}$$

Thus C(t) is minimum for optimal time interval,

$$t_0 = \sqrt{\frac{2C_3}{C_1 R}} \dots\dots\dots (2)$$

Optimum quantity q_0 to be ordered during each order,

$$q_0 = R t_0 = \sqrt{\frac{2C_3 R}{C_1}} \dots\dots\dots (3)$$

This is known as the optimal lot size (or economic order quantity) formula by r. H. Wilson. It is also called Wilson's or square root formula or Harris lot size formula.

Any other order quantity will result in a higher cost.

The resulting minimum average cost per unit time,

$$\begin{aligned} C_0(q) &= \frac{1}{2} C_1 R \cdot \frac{2C_3 + C_3}{\sqrt{C_1 R}} + \frac{C_1 R}{\sqrt{2C_3}} \\ &= \frac{1}{\sqrt{2}} \sqrt{C_1 C_3 R} + \frac{1}{\sqrt{2}} \sqrt{C_1 C_3 R} = \frac{2C_1 C_3 R}{\dots\dots\dots} \dots\dots (4) \end{aligned}$$

Also, the total minimum cost per unit time, including the cost of the item

$$= \sqrt{2C_1 C_3 R} + CR, \dots\dots\dots (5)$$

Where C is cost/unit of the item

Equation (1) can be written in an alternative form by replacing t by q/R as

$$C(q) = \frac{1}{2} C_1 q + \frac{C_3 R}{q}$$

The average inventory is $\frac{q_0 + 0}{2} = \frac{q_0}{2}$ and it is time dependent.

It may be realised that some of the assumptions made are not satisfied in actual practice. For instance, in real life, customer demand is usually not known exactly and replenishment time is usually not negligible.

Corollary 1. In the above model, if the order cost is $C_3 + bq$ instead of being fixed, where b is the cost of order per unit of item, we can prove that there no change in the optimum order quantity due to changed order cost.

Proof. The average cost per unit of time, $C(q) = \frac{1}{2} C_1 q + \frac{R}{q} (C_3 + bq)$.

From equation (5),

$$\frac{dC(q)}{dq} = 0 \text{ and } \frac{d^2 C(q)}{dq^2} \text{ is positive}$$

$$\text{That is, } \frac{1}{2} C_1 - \frac{RC_3}{q^2} = 0 \text{ or } q = \sqrt{\frac{2RC_3}{C_1}},$$

$$\text{and } \frac{d^2 C(q)}{dq^2} = \frac{2RC_3}{q^3}, \text{ which is necessarily positive for above value of } q.$$

$$q_0 = \sqrt{\frac{2C_3 R}{C_1}}, \text{ which is the same as equation (3)}$$

Hence, there is no change in the optimum order quantity as a result of the change in the cost of order.

Corollary 2. In the model in figure discussed above, the lead time has been assumed to be zero. However, most real life problems have positive lead time L from the order for the item was placed until it is actually delivered. The ordering policy of the above model therefore, must satisfy the reorder point.

If L is the lead time in days, and R is the inventory consumption rate in units per day, the total inventory requirements during the lead time = LR . Thus we should place an order q as soon as the stock level becomes LR . This is called reorder point $p = LR$.

In practice, this is equivalent to continuously observing the level of inventory until the reorder point is obtained. That is why economic lot size model is also called continuous review model.

If the buffer stock B is to maintained, reorder level will be

$$P = B + LR \dots\dots\dots (6)$$

Furthermore, if D days are required for reviewing the system,

$$p = B + LR = \frac{RD}{2} = B + R[L + \frac{D}{2}] \dots\dots\dots (7)$$

Assumptions in the EOQ Formula

The following assumptions have been made while deriving the EOQ formula:

1. Demand is known and uniform (constant)
2. Shortages are not permitted; as soon as the stock level becomes zero, it is instantaneously replenished.
3. Replenishment stock is instantaneous or replenishment rate is infinite.
4. Lead time is zero. The moment the order is placed, the quantity ordered is automatically received.
5. Inventory carrying cost and ordering cost per order remain constant over time. The former has a linear relationship with the quantity ordered and the latter with the number of order.
6. Cost of the item remains constant over time. There are no price- breaks or quantity discounts.
7. The item is purchased and replenished in lots or batches.
8. The inventory system relates to a single item.

Limitations of the EOQ Model

The EOQ formula has a number of limitations. It has been highly controversial since a number of objections have been raised regarding its validity. Some of these objections are:

1. In practice, the demand neither known with certainty nor it is uniform. If the fluctuations are mild, the formula can be applicable but for large fluctuations, it loses its validity. Dynamic EOQ models, instead, may have to be applied.
2. The ordering cost is difficult to measure. Also it may not be linearly related to the number of orders as assumed in the derivation of the model. The inventory carrying rate is still more difficult to measure and even to define precisely.
3. It is difficult to predict the demand. Present demand may be quite different from the past history. Hardly any prediction is possible for a new product to be introduced in the market.

4. The EOQ model assumes instantaneous replenishment of the entire quantity ordered. The practice, the total quantity may be supplied in parts. EOQ model is not applicable in such a situation.
5. Lead time may not be zero unless the supplier is next-door and has sufficient stock of the item, which is rarely so.
6. Price variations, quantity discounts and shortages may further invalidate the use of the EOQ formula.

However, the flatness of the total cost curve around the minimum is an answer to the many objections. Even if we deviate from EOQ within reasonable limits, there is no substantial change in cost. For example, if because of inaccuracies and errors, we have selected an order quantity 20% more (or less) than q_0 the increase in total cost will be less than 20%.

EXAMPLE 1

A stock keeper has to supply 12000 units of a product per year to his customer. The demand is fixed and known and the shortage cost is assumed to be infinite. The inventory holding cost is ₦ 0.20k per unit per month, and the ordering cost per order is ₦350. Determine

- i. The optimum lot size q_0
- ii. Optimum scheduling period t_0
- iii. Minimum total variable yearly cost.

Solution

Supply rate $R = \frac{12,000}{12} = 1,000 \text{ unit/month}$,

$C_1 = \text{₦ } 0.20\text{K}$ per unit per month, $C_3 = \text{₦ } 350$ per order.

$$i. \quad q_0 = \sqrt{\frac{2C_3R}{C_1}} = \sqrt{\frac{2 \times 350 \times 1000}{0.20}} = 1870 \text{ units/order}$$

$$ii. \quad t_0 = \sqrt{\frac{2C_3}{C_1R}} = \sqrt{\frac{2 \times 350}{0.20 \times 1000}} = 1.87 \text{ months} = 8.1 \text{ weeks between orders}$$

$$iii. \quad C_0 = \sqrt{2C_1C_3R} = \sqrt{2 \times 0.2 \times 12 \times 350 \times (1000 \times 12)} = \text{₦ } 4490 \text{ per year}$$

EXAMPLE 2

A particular item has a demand of 9000 unit/year. The cost of a single procurement is ₦100 and the holding cost per unit is ₦ 2.40k per year. The replacement is instantaneous and no shortages are allowed. Determine

- i. The economic lot size,
- ii. The number of orders per year,
- iii. The time between orders
- iv. The total cost per if the cost of one unit is ₦1

Solution

$$R = 9000 \text{ units/year}$$

$$C_3 = \text{N}100/\text{procurement}, C_1 = \text{N}2.40/\text{unit/year}$$

$$\text{i. } q_0 = \sqrt{\frac{2C_3R}{C_1}} = \sqrt{\frac{2 \times 100 \times 9000}{2.40}} = 866 \text{ units/procurement}$$

$$\text{ii. } n_0 = \frac{1}{t_0} = \sqrt{\frac{2.40 \times 9000}{2 \times 100}} = \sqrt{108} = 10.4 \text{ orders/year}$$

$$t_0 = \frac{1}{n_0} = \frac{1}{10.4} = 0.0962 \text{ years} =$$

iii. 1.15 months between procurement

$$\begin{aligned} \text{iv. } C_0 &= 900 \times 1 + \sqrt{2C_1C_3R} = 9000 + \sqrt{2 \times 2.40 \times 100 \times 9000} \\ &= 9000 + 2080 = \text{N}11080/\text{year} \end{aligned}$$

EXAMPLE 3

A stockist has to supply 400 units of a product every Monday to his customer. He gets the product at ₦ 50 per unit from the manufacturer. The cost of ordering and transportation from the manufacturer is ₦75 per order. The cost of carrying the inventory is 7.5% per year of the cost of the product. Find

- i. The economic lot size
- ii. The total optimal cost (including the capital cost)
- iii. The total weekly profit if the item is sold for ₦ 55 per unit

Solution

$$R = 400 \text{ units/week}$$

$$C_3 = \text{N}75 \text{ per order}$$

$$C_1 = 7.5\% \text{ per year of the cost of the product}$$

$$= \text{N} \left(\frac{7.5}{100} \times 50 \right) \text{ per unit per year}$$

$$= \left(\frac{7.5}{100} \times \frac{50}{2} \right) \text{ per unit per week}$$

$$= N \frac{3.75}{52} \text{ per unit per week}$$

$$\text{i. } q_0 = \sqrt{\frac{2C_2R}{C_1}} = \sqrt{\frac{2 \times 75 \times 400 \times 52}{52}} = 912 \text{ units per order}$$

$$\begin{aligned} \text{ii. } C_0 &= 400 \times 50 + \sqrt{2C_1C_3R} \\ &= 20000 + \sqrt{\frac{2 \times 3.75}{52} \times 75 \times 400} = 20000 + 65.8 \\ &= N20065.80 \text{ per week} \end{aligned}$$

$$\text{iii. Profit } P = 55 \times 400 - C_0 = 22000.80 = N1934.20 \text{ per week}$$

4.0 CONCLUSION

This unit has looked at inventory control as an essential aspect of managerial function. This is the life wire of any firm aspiring for growth, survival, and continuity. The sum of an inventory control system is to minimize costs and establish:

- a. the optimum amount of stock to be ordered
- b. the period between orders

In a given business organisation, an inventory is defined as the total stocks of various kinds including: basic raw materials; partly finished goods and materials; sub-assemblies; office and workshop supplies and finished goods.

An inventory must be carried by a firm for various reasons.

1. Anticipating normal demand
2. Taking advantage of bulk purchase discounts
3. Meeting emergency shortages
4. As a natural part of the production process
5. Absorbing wastages and unpredictable fluctuations

5.0 SUMMARY

The discussion in this unit can be summarized as follows:

Just like any other activity in a business set up, the costs associated with inventories include:

- i. ordering costs;
- ii. holding costs and
- iii. stock out costs

Two basic inventory systems were identified, including:

- i. The Re-order level system and
- ii. The Periodic review system

Two basic inventory control models are currently in use. These include:

- i. Basic Model
- ii. Adapted Basic Model

6.0 TUTOR MARKED ASSIGNMENT

1. What do you understand by the term inventory control?
2. Identify and discuss the different classifications of inventories.
3. Give six limitations of the EOQ model.
4. Outline the assumptions of the EOQ formula

7.0 REFERENCES

- Eiselt, H.A. and Sandblom, C.L. (2012). Operations Research: A Model Based Approach, 2nd ed., New York: Springer Heidelberg
- Gupta, P.K., and Hira, D.S. (2012). Operations Research, New – Delhi: S. Chand & Company.

