



NATIONAL OPEN UNIVERSITY OF NIGERIA

COURSE CODE : EDA 842

**COURSE TITLE:
APPLICATION OF MANAGEMENT INFORMATION
SYSTEMS (MIS) IN EDUCATION**



EDA 842

**APPLICATION OF MANAGEMENT INFORMATION
SYSTEMS (MIS) IN EDUCATION**

Course Developer	Mr. Abu Joseph Eshemokha Dept. of Educational Administration University of Lagos
Course Writers	Mr. Abu Joseph Eshemokha Dept. of Educational Administration University of Lagos Mr. Ajadi Timothy Olugbenga National Open University of Nigeria
Course Editor	Dr. J. K. Adeyemi Faculty of Education University of Benin Benin-City
Programme Leader	Dr. I. O. Salawu National Open University of Nigeria
Course Coordinator	Mr. Ajadi Timothy Olugbenga National Open University of Nigeria



NATIONAL OPEN UNIVERSITY OF NIGERIA

National Open University of Nigeria
Headquarters
14/16 Ahmadu Bello Way
Victoria Island
Lagos
Abuja Office
No. 5 Dar es Salaam Street
Off Aminu Kano Crescent
Wuse II, Abuja
Nigeria
e-mail: @nou.edu.ng
URL: .nou.edu.ng

Published by
National Open University of Nigeria

Printed 2008

ISBN: 978-058-330-0

All Rights Reserved

CONTENTS	PAGE
Introduction.....	1
What You Will Learn in this Course.....	1
Course Aims.....	2
Course Objectives.....	3
Methodology of Studying this Course	6
Working through this Course.....	6
Assessment.....	8
Tutor-Marked Assignment.....	8
Final Examination and Grading.....	9
How to Get the Most from this Course.....	9
Facilitators/Tutors and Tutorials.....	11
Summary.....	12

Introduction

EDA 842: Application of Management Information Systems in Education is a 700 level, second semester course. It is a three credit unit course for all students offering M. Ed. Administration and Planning. The course is also suitable for anyone who wants to learn about the application and usage of Information Technology to every day activities. The course exposes you to an understanding of many of the concepts of Management Information Systems and its application in the administration of educational institutions. It will also assist school administrators to be able to apply these concepts to the tasks and roles that they perform as school heads and chief executives in the education sector.

The course consists of eighteen units in three modules and a course guide. The course takes you through the meaning, overview and basic concepts of information systems in education as well as the meaning of computer, classification of computers, composition of a computer, windows operating system, windows screen layout, electronic word processing using Microsoft excel, text formatting and editing tables in word, formatting and editing of worksheet data, management of spreadsheet with the use of Microsoft excel, the use of e-mail facilities and how to disseminate information with the use of internet services; the usefulness of database to educational institutions and how to connect computer systems to a network as well as the application of all these to educational institutions in the country.

This Course Guide tells you briefly what the course is all about, what course materials you will be using and how you will work your way through these materials. It suggests some general guidelines for the amount of time you should spend on each unit of the course for its successful completion.

The Course Guide also gives you some guidance on your tutor-marked assignment which will be available at the end of every unit. There are regular tutorial classes that are linked to the course at designated centers throughout the country. You are advised to attend tutorial sessions at designated centre close to you.

What You Will Learn in this Course

The overall aim of EDA 842: Application of Management Information Systems in Education is to introduce basic concepts of Information Systems and acquaint you with some important skills needed for the

application of Information Technology to the day-to-day activities in educational organizations.

An understanding of the Application of Management Information Systems in Education is vital because it serves as a framework for the application of Information Technology to administration and other school activities. From time-to-time, Educational administrators need to make decisions, which will interpret the policies and programmes of government of the country as they affect educational institutions. During this course, you will learn about Information Systems as a concept and the roles expected of Educational Administrators in applying Information Systems to daily school activities, such as school records, students' enrolment, t out ratio, income and expenditure of the school.

The course will expose you to an understanding of various types of management support systems available for educational managers which can assist in arriving at a decision without time wastage. Specific reference will be made to other uses of Information Technology.

Course Aims

The aim of the course can be summarized as follows: to provide students with an understanding of the concepts which underlie the use of information technologies for organizations; to enable students to evaluate the appropriate usage of information technologies, to analyze the influence of information technologies to educational organizations, and to plan and manage the security of data and systems. The course also aims to explain:

- i. the meaning of Management Information System and basic concepts of Management Information Systems in Education;
- ii. provide ways of reducing the complexity of information systems in educational organisation to the barest minimum;
- iii. explain information technology (IT) in relation to education;
- iv. describe in details the basic related IT tools such as computer, networks and e-mails as they affect information in educational management;
- v. outline the methods of editing and formatting worksheet data using Microsoft excel;
- vi. explain the meaning and uses of Window Operating System;
- vii. highlight the features of Microsoft Excel Screen layout;
- viii. introduce students to how to use Microsoft Excel to draw charts and graphs; and
- ix. introduce students to how to use computer or internet purposes.

Course Objectives

To achieve the aims set out, the course sets overall objectives. Each unit also has specific objectives at the beginning of the unit; you should read them carefully before you start working through the unit. You may want to refer to them during your study of the unit to check on your progress. You should also look at the unit objectives after completing a unit. In doing so, you will be sure that you have followed the instructions in the unit.

Below are the wider objectives of the course as a whole. By meeting these objectives, you should have achieved the aims of the course.

On successful completion of the course, you should be able to:

- define management, information and systems;
- list the various managerial levels and their functions;
- distinguish between data and information;
- identify the characteristics of good information;
- define management information systems;
- mention the characteristics of management information systems;
- highlight the objectives of management information system;
- list the factors to be considered when designing management information systems;
- state the problems of management information systems and solutions to the identified problems;
- state the issues addressed by MIS;
- explain Technology for management reforms;
- identify institutional goals of MIS;
- define Information Technology;
- explain application, of IT in Information Management;
- define a computer;
- classify computers based on type, size/capacity, and nature of location;
- mention the structure of a computer;
- explain the component and configuration of a computer;
- lists the various parts of a computer;
- explain the meaning of a computer virus;
- define computer hardware and software;
- describe what is meant by Booting;
- list the procedure of shutting down the computer system;
- define Window Operating system;
- recognize the window environment;
- identify a computer mouse;

- identify the basic techniques on how to use the mouse;
- distinguish between menu and menu conventions;
- explain the meaning of a shortcut and how to create shortcut;
- demonstrate how to open an icon and differentiate between selecting and choosing an icon;
- define a dialog box;
- define windows, label its different parts, and practice how to minimize, restore, maximize, close and resize a window;
- explain how to use the scroll arrow and scroll box;
- change the background or wallpaper and screen saver of a window;
- set the date of a computer;
- define Microsoft word and how to load it;
- recognize the screen layout and the features;
- identify toolbar and how to arrange them;
- differentiate between active and inactive commands;
- explain how to set up a page before creating a new document;
- creating a new document, save and open it;
- demonstrate how to save and open a file in a removable disks;
- explain how to select text;
- format text in terms of font, size, style, alignment;
- spell check a document;
- find and replace text and find synonyms of words;
- show how to space lines of text ;
- copy, cut and paste text;
- explain how to redo and undo commands;
- insert page number and create header and footer;
- insert table and enter text into a table;
- select table and other parts such as columns, rows and cells;
- insert and delete columns and rows whenever there is need;
- show how to direct text in table's cell vertically and alignment cells entries;
- adjust row height and column width to fit the text;
- show how to sort table, data either in ascending order;
- split/merge table's cells to give more information;
- explain how to apply borders to a table;
- apply colours shading to text in order to create distinctive emphasis;
- apply page boarder to make the document look attractive;
- create a file in word pad;
- define a recycle bin;
- rename and delete file or folder;

print a document;

- define spread sheet management and give the definition of MS-Excel;
- load Excel and recognize the Welcome Screen environment and features;
- define columns, rows, workbook, worksheet cells and range of cells;
- enter worksheet data to create a document;
- explain how to edit the content of a cell;
- adjust columns' width and rows' height;
- select various parts of a worksheet such as columns, rows, cells range;
- demonstrate how to delete columns and rows;
- insert rows and columns and worksheet;
- explain the term e-mail;
- mention the requirements for e-mail and e-mail sites;
- describe the procedure of how to open and activate e-mail;
- explain how to sign-in, compose a message, reply to message and sign out;
- list the benefit of e-mail;
- insert rows, columns into a worksheet;
- insert a new worksheet and rename worksheet;
- protect and delete a worksheet;
- hide and unhide column and rows;
- fill preset data;
- align worksheet data;
- change the orientation of text;
- practicalize how to paste, copy or cut cells entries;
- sort data either in ascending or descending order;
- show how to assign number format;
- apply border to selected cells;
- use header and footer for more information;
- show how to insert charts;
- mention the different parts of a chart;
- select chart items;
- format the different parts of a chart;
- define database and DBMS;
- identify parts of a database;
- create a database and edit it;
- define format and know types of formula in excel;
- describe samples of excel formula;
- use AutoSum to sum up;
- define Network;
- list the benefits of Network in Education;

give brief history of internet;

- define internet;
- highlight the types of internet connection;
- explain the addressing system on the internet;
- distinguish between internet and World Wide Web (www);
- mention the importance of internet in MIS to education; and
- list the various terms associated to www and internet.

Methodology of Studying this Course

Apart from Module 1 which is theoretical in nature, Module 2 & 3 are more of practical. This makes MIS in education to be different from other education courses. Therefore, you are advised to have a personal computer (PC) to enjoy the full benefits of the course. The practical exercises are organized using a simple "Desktop PC" which may be slightly different from other types of computers such as laptop, palmtop, etc. The obvious slight difference is on the use of keyboard and mouse. For example, using the laptop mouse to drag will not be so easy for an amateur. However, as the saying goes – "practice makes perfect". However, you can fix external mouse like that of the desktop to your laptop if you are finding it extremely difficult to click and drag with the attached mouse.

Working through this Course

To complete this course, you are required to read all the study units in the study material, read the set books and other materials provided by the National Open University of Nigeria (NOUN). You are also expected to familiarize yourself with a computer laboratory for necessary experience and skills needed for the course. Each unit has self assessment practice exercises, and at regular intervals in the course, you are required to submit assignments/exercises for assessment purposes. At the end of the course, is a final examination. The course should take you about 17 weeks in total to complete. Below, you will find listed all the components of the course, what you have to do and how you should allocate your time to each unit in order to complete the course successfully on time.

Units	Titles of Work	Number of Weeks to Spend
Module 1		
Units 1 & 2	Overview of Management Information Systems in Education and Management	1
Unit 3	Systems Information Technology and MIS in Education	1
Unit 4 & 5	IT and MIS in Education and Computer Appreciation – Hardware and Software	1
Module 2		
Unit 1	IT and MIS in Education – Windows Operating System	1
Unit 2 Unit 3	Windows Operating System Continued <u>IT and MIS in Education: Computer</u> Electronic Word Processing using MS-Word – MS-Word Welcome Screen and Features	2
Unit 4	<u>Microsoft Word (MS-Word) – Text</u> Formatting Editing	1
Unit 5	<u>Microsoft Word Continued – Tables in</u> MS-Word	2
Unit 6	<u>Microsoft Word – More Formatting, Editing, and Printing</u>	1
Module 3		
Unit 1	<u>IT and MIS in Education: Computer</u> Spreadsheet Management using MS-Excel, Excel Welcome Screen and Features	1
Unit 2	<u>MS-Excel Continued: Formatting and Editing of Worksheet Data</u>	1
Unit 3	MS-Excel Continued: More Formatting and Editing of Worksheet Data	1
Units 4 & 5	MS-Excel Continued: Database and Charts	17
Units 6 & 7	IT and MIS in Education (Networks) and IT and MIS in Education (e-mail)	
Total		

Each study unit consists of one to two weeks work, and includes introduction, objectives, reading materials, exercises, conclusion, summary, tutor-marked assignments (TMAs) and marking scheme, references/further readings. In general, these exercise/practice questions, test you on the materials you have just covered and to reinforce your understanding of the materials. Together with the tutor-marked assignments, these exercises will assist you in achieving the

stated learning objectives of the individual units and of the course.

Assessment

There are three aspects to the assessment of the course; the first is the self assessment/practice, the second is the tutor-marked assignments; and the third is the end of the semester written examination.

In tackling the assignments, you are advised to be sincere in attempting the exercises/practices; you are expected to apply the information, knowledge and techniques gathered during the course. The assignments must be submitted to your tutor for formal assessment in accordance with the deadlines set by the authority of National Open of Nigeria (NOUN). The tutor-marked assignments you submit to your tutor will count for 40% of your total course mark.

At the end of the course, you will need to sit for a final written examination of three hours duration. This examination will also count for 60% of your total course mark.

Tutor-Marked Assignment

There are eighteen (18) tutor-marked assignments in this course. You are advised to submit all the assignments in which case, the best four will be counted for you. Each assignment counts 10% towards your total course mark.

Assignment questions/Practice Exercises for the units in this course will be contained in the *Assignment File*. You will be able to complete your assignments from the information and materials contained in your reading, references and study units. However, it is desirable in all degree level education to demonstrate that you have read and researched more widely than the required minimum. Using other references will give you a broader viewpoint and may provide a deeper understanding of the subject.

When you have completed each assignment, send it together with the TMA (Tutor-Marked Assignment) form, to your tutor. Make sure that each assignment reaches your tutor on or before the deadline set by the authority of National Open University Nigeria (NOUN) which will be made known to you through your study center. If for any reason, you cannot complete your work on time, contact your tutor before the assignment is due for submission to discuss the possibility of an extension. Extension will not be granted after the due date except in exceptional circumstances.

Final Examination and Grading

The final examination for EDA 842 will be of three hours' duration and have a value of 60% of the total course grade. The examination will consist of questions, which reflect the types of self-testing, practice exercises and tutor-marked assignments you previously attempted. All areas of the course will be assessed.

Use the time between finishing the last unit and sitting for the examination to revise the entire course. You will find it useful to review your self-tests, tutor-marked assignments and the comments on them before the examination. The final examination covers information from all parts of the course.

How to Get the Most from this Course

In distance learning, the study units replace the university lecturer. This is one of the great advantages of distance learning. You can read and work through specially designed study materials at your own pace, and at a time and place that suit you best. Think of it as reading the lecture instead of listening to a lecturer. In the same way that a lecturer might set you some reading to do, the study unit will tell you when to read other materials. Just as a lecturer might give you an in-class exercise, the study units provide exercises for you to do at appropriate time.

Each of the units follows a common format. The first item is an introduction to the subject matter of the unit and how a particular unit is integrated with the other units and the course as a whole.

Next is a set of learning objectives. These objectives let you know what you should be able to do by the time you have completed the unit. You should use these objectives to guide your study. When you have finished the unit you must go back and check whether you have achieved the objectives. If you make a habit of doing this, you will significantly improve your chances of passing the course.

The main body of the unit guides you through the required reading from other sources. This will usually be either from a Reading Section of some other sources.

Self-help practices are interspersed throughout the end of the units.

Working through these practices will help you to achieve the objectives of the unit and prepare you for the assignments and examination. You should do each self-test exercise as you come to it in the study unit.

There will also be numerous examples given in the study units, work through these when you come to them too.

The following is a practical strategy for working through the course. If you run into any trouble, telephone your tutor. Remember that your tutor's job is to assist you when you need help, therefore do not hesitate to call and ask your tutor to assist you.

- Read through this Course Guide thoroughly.
- Organise a study schedule. Refer to the Course Overview for more details. Note the time you are expected to spend on each unit and how the assignments relate to the units. Important information e.g. details of your tutorials, and the date of the first day of the semester will be made available through the study centre. You need to gather all these information in one place, such as your diary or a wall calendar. Whatever method you choose to use, you should decide on and write in your own dates for working through each unit of the course.
- Once you have created your own schedule, do everything you can to stick to it. The major reason that students fail is that they get behind with their course work. If you get into difficulties with your schedule, please keep your tutor informed before it is too late for help.
- Turn to Unit I and read the introduction and the objectives for the unit.
- Assemble the study materials. Information about what you need for a unit is given in the "*Overview*" at the beginning of each unit; you will always need both the study unit you are working on and the one on your references, on your desk at the same time.
- Working through the unit. The content of the unit itself has been arranged to provide a sequence for you to follow. As you work through the units, you will be instructed to read sections from your other sources. Use the unit to guide your reading.
- Well before the relevant due date, check your assignment file and make sure you attend to the next required assignment. Keep in mind that you will learn a lot by doing the assignments carefully. They have been designed to help you meet the objectives of the course and, therefore, will help you pass the examination. Submit all assignment not later than the due date.

- Review the objectives for each study unit; confirm that you have achieved them. If you feel unsure about any of the objectives, review the study material or consult your tutor.
- When you are confident that you have achieved a unit's objectives, you can then start on the next unit. Proceed unit by unit through the course and try to face your study so that you keep yourself on schedule.
- When you have submitted an assignment to your tutor for marking, do not wait for its return before starting on the next unit. Keep to your schedule. When the assignment is returned, pay particular attention to your tutor's comments, both on the tutor-marked assignment form and also on the comments written on the assignment. Consult your tutor as soon as possible if you have questions or problems.
- After completing the last unit, review the course and prepare yourself for the final examination. Check that you have achieved the unit objectives (listed at the beginning of each unit) and the course objectives (listed in the course guide).

Facilitators/Tutors and Tutorials

There are tutorial hours provided by the National Open University of Nigeria (NOUN) in support of this course. You will be notified of the dates, time and location of these tutorials, together with the names and telephone number of your tutor, as soon as you are allocated a tutorial group.

Your tutor will mark and comment on your assignments, keep a close watch on your progress and on any difficulties you might encounter and provide assistance to you during the course. You must submit your tutor-marked assignments to your tutor well before the due date. They will be marked by your tutor and returned to you as soon as possible. Do not hesitate to contact your tutor by telephone, e-mail, or discussion board if you need help. The following might be circumstances in which you would find help necessary.

Contact your tutor if:

You do not understand any part of the study units or the assigned readings.

You have difficulty with the self-test or exercise.

You have a question or problem with an assignment you have a question with your tutor's comment on an assignment or with the grading of an assignment.

You should try your best to attend the tutorials. This is the only chance to have face-to-face contact with your tutor and to ask questions which are answered instantly. You can see any problem encountered in the course of your study. To gain the maximum benefit from course tutorials, prepare a question list before attending them. You will learn a lot from participating in discussion actively.

Summary

EDA 842 (Application of Management Information Systems in Education) intends to introduce the concepts and theories of Management Information Systems in Education to you. Upon completion of this course, you will be equipped with the basic knowledge of the important concepts of Management Information Systems and the importance of Information Technology to educational administration.

You will be able to answer these kinds of questions:

- What is Management Information Systems?
- What are the functions of information in an organisation?
- What are the challenges of Management Information Systems in Education in Nigeria?
- What is data transmission?
- What is the difference between Half-Duplex and Duplex under data
- How can we categorize computer?
- What are the similarities between computer virus and animal virus?
- What is the name of part of the scroll bar you should use if you intend to scroll fast?
- What is the name of the bar you will use to carry a dialog box or a window
- Which keys are peculiar to a computer keyboard that are not in the manual typewriter keyboard
- How can you save file in a new diskette?
- Mention three external hard disc you can use as a back-up for your files
- How can you select a single word with the mouse?
- What is the keyboard shortcut for double and single lines spacing?

- How can you insert 10 X 6 tables to reveal information of students in various subjects?
- What is the distinguishing factor between a workbook and a worksheet?
- Which keyboard will you press if you want to see the last Row and
- Column?
- Mention some e-mail sites that offer free e-mail services to individual?
- What are the disadvantages of deleting a worksheet from a workbook?
- What are the limitations to be encountered when using the sort icon on the standard tools bar to sort a data base?
- What are the functions of DBMS?
- What is a web page and hyperlink?

Indeed, the list of questions that you can answer is not limited to the above. To gain the most from this course you should try to apply the principles and concepts of Management Information Systems to the practice of administration of educational institutions.



Course Code	EDA 842
Course Title	Application of Management Information Systems (MIS) in Education
Course Developer	Mr. Abu Joseph Eshemokha Dept. of Educational Administration University of Lagos
Course Writers	Mr. Abu Joseph Eshemokha Dept. of Educational Administration University of Lagos Mr. Ajadi Timothy Olugbenga National Open University of Nigeria
Course Editor	Dr. J. K. Adeyemi Faculty of Education University of Benin Benin-City
Programme Leader	Dr. I. O. Salawu National Open University of Nigeria
Course Coordinator	Mr. Ajadi Timothy Olugbenga National Open University of Nigeria



NATIONAL OPEN UNIVERSITY OF NIGERIA

National Open University of Nigeria

Headquarters

14/16 Ahmadu Bello Way

Victoria Island

Lagos

Abuja Office

No. 5 Dar es Salaam Street

Off Aminu Kano Crescent

Wuse II, Abuja

Nigeria

e-mail: @nou.edu.ng

URL: .nou.edu.ng

Published by

National Open University of Nigeria

Printed 2008

ISBN: 978-058-330-0

All Rights Reserved

CONTENTS	PAGE
Module 1	1
Unit 1 Overview of Management Information Systems in Education.....	1
Unit 2 Meaning of Management Information Systems (MIS).....	14
Unit 3 Information Technology (IT) and MIS in Education.....	24
Unit 4 IT and MIS in Education: Computer Appreciation.....	31
Unit 5 Computer Appreciation Continued: Hardware and Software.....	37
Module 2	53
Unit 1 IT and MIS in Education: Windows Operating System.....	53
Unit 2 Windows Operating System Continued: Windows Screen Layout.....	66
Unit 3 IT and MIS in Education Computer Electronic Word Processing using MS-Word: MS-Word Screen	
Unit 4 Layout and Features.....	76
Unit 5 Microsoft Word (MS-Word) Continued: Text Formatting and Editing.....	96
Unit 6 Microsoft Word Continued: Tables in MS-Word	113
Microsoft Word Continued: More Formatting, Editing and Printing.....	127
Module 3	136
Unit 1	xx
Unit 2	
Unit 3	
Unit 4	
Unit 5	

IT and MIS in Education	Computer	and	
Spreadsheet Management using	MS-Excel	Editing of Worksheet Data	150
MS-Excel		MS-Excel Continued: More Formatting	
Welcome Screen and		and Editing of Worksheet Data.....	164
Feature.....	136	Microsoft Excel Continued: Database.....	177
MS-Excel Continued: Formatting		Microsoft Excel Continued: Charts.....	198

MODULE 1

- Unit 1 Overview of Management Information Systems in Education
- Unit 2 Management Information Systems (MIS)
- Unit 3 Information Technology (IT) and MIS in Education
- Unit 4 IT and MIS in Education: Computer Appreciation
- Unit 5 Computer Appreciation Continued: Hardware and Software

**UNIT 1 OVERVIEW OF MANAGEMENT
INFORMATION SYSTEMS IN EDUCATION****CONTENTS**

- 1.0 Introduction
- 2.0 Objectives
- 3.0 Main Content
 - 3.1 Management
 - 3.1.1 Process
 - 3.2 Managerial Functions
 - 3.2.1 Planning
 - 3.2.2 Organising
 - 3.2.3 Coordinating
 - 3.2.4 Commanding
 - 3.3 Levels of Management
 - 3.3.1 Top or Strategic Level of Management
 - 3.3.2 Middle or Tactical Level of Management
 - 3.3.3 Lower or Operational Level of Management
 - 3.4 System
 - 3.4.1 Open Systems
 - 3.4.2 Close Systems
 - 3.5 Data
 - 3.5.1 Data Processing
 - 3.5.2 Stages of Data Processing
 - 3.6 Information
 - 3.6.1 Characteristics or Attributes of Good Information
 - 3.6.2 Forms of Information
 - 3.6.3 Functions of Information
- 4.0 Conclusion
- 5.0 Summary
- 6.0 Tutor-Marked Assignment
- 7.0 References/Further Readings

1.0 INTRODUCTION

In the present day educational system, management information system cuts across all disciplines, from Accounting to Medicine, Pharmacy, Engineering/Electrical/Electronics, Banking, Administration, Education etc. We must bear in mind that in the application of management information system in education, we are dealing with the concept of management and technology, and how we can harmoniously use the duo to achieve effective medium for analyzing educational information. Therefore, this aspect of the course serves as a preamble for you to know the rudiments of the course.

2.0 OBJECTIVES

At the end of this unit, you should be able to:

- define management, information and systems
- list managerial levels and functions
- distinguish between data and information
- describe how data are processed to give information
- identify the characteristics of good information and functions of information.

3.0 MAIN CONTENT

3.1 Management

Like most terms in the Social Sciences, no definition has been universally accepted in relation to management. However, some scholars and practising managers have all attempted to provide definitions based on their understanding of the prevailing situation.

Some define management as the force that runs an enterprise and others claim that management is the performance, conceiving and achieving desired result by means of group effort, consisting of utilizing human talents, resources and skills. Others state that management is the satisfaction of economic and social needs through production as a result of human efforts. Others summarise management as planning and implementation.

According to Leon Magison et al (1983), "Management is working with people to determine, interpret, and achieve organisational objectives by planning, organising, leading, controlling and staffing."

It is important to know that Henry Fayol's, definition (Cole: 1986) is closely related to the above definition. Fayol was the first to give comprehensive and summarised definition of management. He defined Management as: "to forecast, plan, organize, command, coordinate and control".

In Fayol's view, to forecast plan mean to examine the future and draw up a plan of action. To organize means building a structure of both material and human in an organisation. To command means maintaining activities among employees. To control, means to ensure everything is in conformity with the plan and standard.

Therefore, Management is the process of planning, organizing, leading and controlling the effort of organisational members and using all other resources to achieve stated organisational goals.

3.1.1 Process

A process is a systematic way of doing things, hence we define management as a process because all managers regardless of their particular attitude or skill engage in certain related activities in order to achieve their objectives.

In order to achieve the objectives of the organisation, it is necessary to bring together all available resources called "six Ms" of management i.e. men, machine, material, methods, money and market. These resources are brought together and related in harmony and honesty so that the end result may be accomplished by all within the determined constraint of time, effort and cost.

3.2 Managerial Functions

The major functions of management include the following:

3.2.1 Planning

Planning is the first of the five basic managerial functions. It is argued to be the most important function of a manager. Planning, therefore, means setting objectives and determining what should be done to accomplish them, i.e. today's design for tomorrow's action. Planning is an applied problem solving and decision making efforts through which managers act to insure the future success of their organisation as well as themselves. It could be considered as, deciding in advance what to do, how to do it, where to do it, who should do it, and when to do it in order to achieve effectiveness at every level of responsibility.

As a foundation of management process, planning identifies what should be done and set the stage for further managerial efforts at organising, leading and controlling. In other words, planning is the function that answers four questions.

1. Where are we now? – This question is concerned with assessing the present situation and forecasting how the situation may change in the future.
2. Where do we want to be? – Answer to this question involves determining the desired objective in terms of the present and future
3. What is the difference between where we are and where we want to be?
4. How can we get there? – This question requires an outline of action and a careful analysis of future implication of present decision.

3.2.2 Organising

Harold Koontz (1980) defined organising as that part of management that involves establishing an intentional structure of roles for people to fill in an organisation. It is intentional in the sense of making sure that all the tasks necessary to accomplish goals are assigned and especially, assigned to people who can do them best.

Organising can be viewed as the process of identifying and grouping of work to be performed, by defining and delegating responsibility and authority and establishing relationship for the purpose of enabling people to work effectively together in order to accomplish the objective.

In a simpler way organising is the process of arranging people to work with one another towards their common goal. It implies first of all that there is a collection of people combining their effort to accomplish what none could do alone. This is sometimes referred to as synergy, i.e. the concept that the whole organization as it works harmoniously and cooperatively is greater than some of its parts.

3.2.3 Coordinating

Coordinating is perhaps the closest word to a true synonymy of management. The challenge of coordinating is to capitalize on individual difference while maintaining control.

Coordinating is therefore the function of management that involves harmonizing and synchronizing all efforts of individuals and units to achieve a common objective.

Coordinating can also be seen as the process of integrating the objectives and activities of the separate units (departments or functional areas) of an organisation, in order to achieve the organisational goal efficiently. Without coordination, individuals and departments would lose sight of their role within the organisation. They will begin to pursue their own personal interest often at the expense of the larger organizational goals.

3.2.4 Commanding

Another function of management is **directing** or **leading**. Commanding is influencing people so that they will contribute to organisation and group goals. A manager's leading ability i.e. manager's ability to motivate, influence and communicate with subordinate will determine manager's effectiveness. For managers to command effectively, three basic elements have to be considered jointly: Leadership, Communication and Motivation.

1. **Leadership:** It means headship. People tend to follow those who offer means of satisfying their needs, wishes and desires. On the other hand, leadership is the relationship in which one person – the leader, influences others to work together willingly on related tasks to attain that which the leader desires.
2. **Communication:** It deals with the acts of developing and attaining understanding. It can be verbal and non-verbal. Communication is a means to an end. It makes possible the management process and serves as a lubricant for a smooth operation. Effective communication enables manager to obtain data for decision making.
3. **Motivation:** How can I get my members to care more about their work? What kind of condition brings the best out of them? What motivates employees to do their best and derive their satisfaction from the work? Questions such as these are foremost in most managers' mind. In the opinion of many, the key to performance is motivation.

Motivation is the desire within an individual that stimulates him or her to action. Motivation of people deals with the way of removing conditions, which make people dissatisfied with their work. Each employee has his own acceptance zone. Instructions falling within this zone will be carried out to the best of his ability while those outside it

will be trampled or even sabotaged. The rule of motivation is to enlarge this zone.

3.2.5 Controlling

Management control is the process through which managers are sure that the actual activities conform to the planned activities. Controlling is making sure that every thing happens according to plan.

In the plan of an organisation's activities, the fundamental goals and the objectives and the method of attaining them are established. The control process measures progress towards these goals and enables managers to detect deviation from the plan in time and to take corrective action before it is too late.

3.2.6 Staffing

At times some people will treat staffing separately as managerial function while some will refer to it under coordination.

However, staffing involves filling, and keeping the filled position in the organisation structure. This is done by identifying work-force requirement, recruiting, selecting, planning, promoting etc, candidates and current job holders to accomplish their task effectively and effectively.

SELF ASSESSMENT EXERCISE 1

Define the term Management and vividly explain the functions of Management.

3.3 Levels of Management

There are three levels of management in all formal organisations and there are clear differences in information requirements and decision making at each level. The three levels of management are: top or strategic management, middle or tactical management; and junior or operational management.

3.3.1 Top or Strategic Level of Management

This is the peak of the management levels. It consists of the corporate officers that are elected by the board of directors. In the education industry, they are the ministers/commissioners appointed by the President/Governor, Chief Executive Officers (CEO), Chairman, general

manager and their deputies etc. for the ministries, parastatals and agencies.

It has to do with policy formulation or gathering data to meet up with the prevailing situation in an organisation. In Nigeria for instance, policies on higher institutions, nomadic education, primary and post primary institutions are strategic policies. Also, Post UME Policy that was introduced in 2006 is an example of strategic policy.

In summary, the functions of strategic level managers include:

- Formulating broad policies.
- Working out long-range planning.
- Determining organisation objectives and goals.
- Appointing other top level officers.
- Authorizing new facilities and launching research and development projects.

3.3.2 Middle or Tactical Level of Management

Middle level managers are in between the top and lower level managers. Managers at this level spend most of their time analyzing data, preparing information for decisions and translating top level management overall policies and strategy into operational policies, procedures and methods of work. Vice Chancellors, Provosts, Rectors, Administrators, Principals, Proprietors/Proprietress etc of various schools are good examples of tactical managers.

Tactical level management functions include:

- Assisting top level managers in executing their functions.
- Transferring information and materials between different work groups
- Preparing plans and programs for various departments.
- Management and control of activities of lower level manager.

3.3.3 Lower or Operational Level of Management

Operational level is the supervisory level. The supervisors do not manage other managers but spend more of their time with subordinates and peers to oversee the activities of the front line employees and ensure that they carry out their daily tasks as expected. The heads of departments (HOD) in schools are good examples of lower level managers in education.

The operational level of management functions include:

- Directing all workers to accomplish their departmental goals.
- Maintaining discipline and order.
- Taking decisions to meet up with the challenges in his domain.
- Executing the policies of top management level passed through middle level of management.

3.4 System

A system is a collection of interrelated parts, which form a whole. A system may be seen as a combination of interrelated elements, or sub-systems, organized in such a way that the efficient functioning of the system as a whole, is ensured, necessitating a high degree of coordination between the sub-system, each of which is designed to achieve a specified purpose, Systems are 'synergistic'. Synergy is used to describe the concept, which states that the sum of a whole is greater than the sum of individual parts. For example, the human body, communication, information, hospital, accounting, railway etc. A system could be open or close.

3.4.1 Open Systems

Systems that receive inputs from the environment and sometimes return outputs to the environment are called open systems. A system is open if it imports various items from its environment, converts them into goods, services and waste materials and then exports them into the environment.

Here, information is considered as an open system because it interacts with the environmental factors such as: social factors, economic situation, government influences, technology and physical environment (weather, location etc) which form the inputs to give output in form of products, services, ideas etc to the environment again.

3.4.2 Close Systems

Systems that have sealed boundaries and neither receive input nor produce output are close systems. They are independent of their environment.

Close systems are required for stability and consistency, whereas open systems are required for uncertain conditions. Close systems are designed for efficiency, open systems for survival.

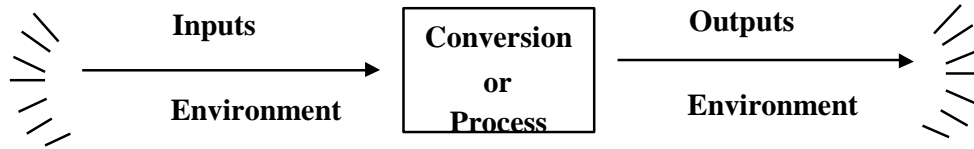

Model of an Open System

3.5 Data

Data are raw facts or information yet to be processed i.e. unprocessed information.

Data means **raw facts** in form of figures, specification, exam records, admission list of students/workers, customer savings, sales figure etc. (Singular-datum, plural-data).

It suffices to say that in order to harmonize all the managerial functions, which could be seen as sub-systems; data have to be processed to get the needed information.

3.5.1 Data Processing

The entire process of information right from the input unit to the output unit is referred to as **Data Processing (DP)**. In other words DP is the term given to the process of collecting all items of data together to produce meaningful information. Data could be processed manually or electronically. However, when it is done on computers, it is known as **Electronic Data Processing (EDP)**. For many years now the methods of DP have involved electronic means, principally, the computer. Subsequently, we shall concentrate on electronic data processing in view of our course of study, because it relies upon information technology and through it, other functions within an organisation can be integrated. However EDP must be seen as one of the important areas in **Information Technology (IT)**. It is the technology, which supports the activities involving the creation, storage, manipulation, and communication of information with their related methods, management and application.

Data will pass through the same basic stages in the same circle even through electronic, conventional or both methods are (is) used to process the data.

Data processing stages can be summarised into what is called Data Processing System as illustrated in the following figure.

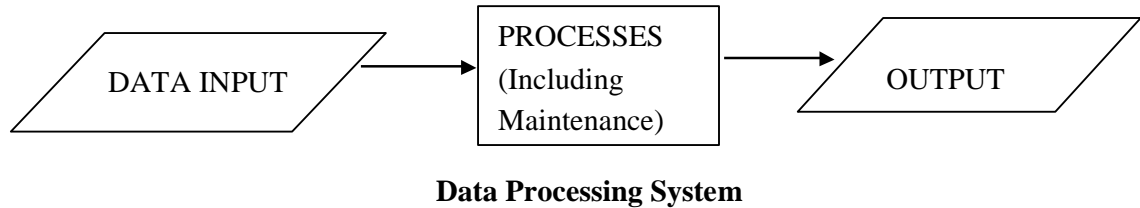

3.6 Information

Information is the processed data i.e. data that have been converted into more meaningful format through data processing.

SELF ASSESSMENT EXERCISE 2

1. Define the following terms – (i) Data (ii) Information
2. What is data processing?

3.6.1 Characteristics or Attributes of Good Information

Good information is that which is encoded by the sender and decoded by the user the way and manner intended by the sender. For information to be good, the following characteristics must be present.

Relevance: Information must be relevant to the problem in question. It is a well known fact that reports, messages, tabulations etc contain irrelevant parts which most often prevent the user of the information to get the actual meaning of what the sender wants.

Accuracy: Although absolute accuracy of information cannot be achieved, information should be sufficiently accurate for management reliance and for the purpose for which it is meant.

Completeness: For management to make good decisions, information relating to that aspect should be complete. However, in practice, this is not often obtainable. Therefore, what is expected is that information is complete in relation to the key elements of the problem. This suggests that there should be interaction between information providers and users to ensure that the key factors are identified.

Confidence in the source: The use of information determines its value. And manager use information when there is confidence in the source. Confidence is built when there is:

- a) Past reliance on the source; and
- b) Existence of good communication between the information producer and the manager.

Communication to the right person: It is often common for information to be directed to the wrong level in an organisation. Since each administrator at different levels needs information to perform his duties and responsibilities, information suppliers should ensure that information goes straight to the right person and not to subordinates who may at times hold on to it for others to see how important he/she is in the organisation.

Timing: For information to be good it has to be communicated at the right time, hence it will end up in the dust bin.

Information should be provided based on the frequency, which is related to the type of decision or activity involved. The intervals of passing information across may be longer at higher levels (strategic and tactical) than the lower level (operational). At the lower level information may be made available regularly for example, on a V.D.U. screen or on electronic boards.

Detail: Information should contain everything considered to be useful for effective decision making. This does not mean that users of information of whatever level must be overloaded with unnecessary information, however information should be selectively as filtered, summarized, edited and highlighted as appropriate as possible.

Channel of Communication: Effective information is seen when the sender gets the feedback as intended. And the major determinants of accuracy of the feedback are the appropriateness of channels of communication involved. Therefore, adequate channel must be considered when disseminating information.

Understandability: It has been said under the definition of data above; that what transforms data into information is understandability. For information to be good, it must be understood.

3.6.2 Forms of Information

There are various forms of information; some of them are discussed below:

Formatted Information: This kind of information includes *alphanumeric* items that have been arranged in a pre-specified format whereby the result of each item is defined in advance. For instance, a table that contains a student's records in form of Name, Age, Class, Assessment, Exam, Total, Average, etc.

Texts: information in form of text i.e. letters, numbers and symbol, could be combined in such a manner that immediate meaning and

interpretation could be derived to give information. There is no prespecified format here.

Images: Information that is generated through picture, basic shapes, photographs, and hand-drawn pictures. Example is an artist designs and drawings.

Audio: This is information in the form of sound. For instance, a doctor might gather some information about an unconscious patient, just by listening to the sound of the stethoscope.

Video: Video information combines the features of both image and audio information. That is information in form of sound and graphics.

3.6.3 Functions of Information

Means of Communication: Managers at all levels act on information to communicate with one another in order to know about developments, plans, forecasts, inherent changes etc, in the organisation.

Aid to monitoring and control: An organisation acts on information to know about performance and the extent of deviation from planned objectives and appropriate control measurements to be implemented.

Reduction of uncertainty: The future of every organization is oblique. Nobody knows what the future has to offer because of some environmental factors; however, information helps to reduce such uncertainties in the process of planning and decision making. For instance, planning to have tuition-free post primary institutions for the next twenty years is uncertain, because of some obvious factors such as population, economy, but information about such factors will help to reduce the uncertainties.

Aid to simplification: Because information helps to reduce uncertainty, it then follows that problems and solutions are simplified and become more manageable.

Memory Supplement: Information of past history helps to supplement the actions of managers. For example in Nigeria, free education, which was a manifesto of the Action Group (AG) party in the first republic, was implemented and it witnessed a huge success and the products were good in terms of knowledge. In the same vein, United Peoples Party (UPN) 1979 – 1984 implemented the same policy but it was only partly successful as their products were only average in terms of knowledge compared with those of the Action Group.

Between 1999 and 2003, some states where the Alliance for Democracy Party (AD) ruled tried to implement the same free education policy, but their products were not as good in comparison with those from the earlier periods.

Historical information such as the ones related above, could help any educational administrator in formulating policies and taking decisions on free education whenever he/she is called upon.

4.0 CONCLUSION

MIS exists in organisations in order to help them achieve their objectives, to plan, control and coordinate the six 'Ms' of management and meet with the challenges of the ever-changing environment characterized by GETS (Government, Economy, Technology and Society).

5.0 SUMMARY

Management Information System is looked at as ways of processing data of an organisation into information, which is then used for accurate decision making at strategic, tactical and operational levels of management.

6.0 TUTOR-MARKED ASSIGNMENT

1. For information to be good, it must possess some characteristics. Discuss.
2. Name the levels of Management known to you and write short notes on any two.
3. What are the functions of information in an organization?

7.0 REFERENCES/FURTHER READINGS

Lucey, T. (1997). *Management Information Systems*, 8th Edition, Ashford Colour Press: Gosport Hampshire.

Bidmos, F. (2004). *Understanding Computer Applications and Management Information Systems*, Panaf Press: Lagos, Nigeria.

Cole G. A. (May 1986). *Management Theory and Practices*, Second Edition, London: Methuen.

UNIT 2 MEANING OF MANAGEMENT INFORMATION SYSTEMS (MIS)

CONTENTS

- 1.0 Introduction
- 2.0 Objectives
- 3.0 Main Content
 - 3.1 Management Information Systems
 - 3.2 Objectives MIS
 - 3.3 Need for Management Information Systems
 - 3.4 Characteristics of MIS
 - 3.5 The Design of MIS
 - 3.6 Problems with MIS and Solutions to the Problems
 - 3.7 Issues Addressed by Management Information System in Education
 - 3.8 Technology for Management Reform
 - 3.8.1 Management of Institutions and Systems
 - 3.8.2 Management of Policy Making
 - 3.8.3 Managing of Learning Activities
 - 3.9 Institutional Goals of Management Information Systems
 - 3.10 The Role of Management Information System on the Behaviour of Educational Managers
 - 3.11 Challenges of Management Information Systems in Education
- 4.0 Conclusion
- 5.0 Summary
- 6.0 Tutor-Marked Assignment
- 7.0 References/Further Readings

1.0 INTRODUCTION

This unit dwells on the details of what management information systems in education encompass.

2.0 OBJECTIVES

After you have studied this unit, you should be able to:

- define management information systems (MIS)
- mention characteristics of MIS
- highlight objectives of MIS
- list the factors to be considered when designing MIS
- state the problems with MIS and solutions to the problems
- explain issues addressed by MIS in education

- explain Technology for management reforms
- know institutional goals of MIS
- understand the role of MIS on the behaviour of educational managers.

3.0 MAIN CONTENT

3.1 Management Information System

Harold et al (1980), defined management information system as a formal system to gather, integrate, compare, analyze, and disperse information (internal and external) to the enterprise in a timely, effective and efficient manner.

MIS is the combination of human and computer-based resources that results in the collection, storage, retrieval, communication and use of data for the purpose of efficient management of operations and for business planning.

At the strategic level of management, the manager needs information to plan the overall objective of the organisation. Tactical level managers need information to ensure that the resources of the organisation are effectively and efficiently utilized to achieve the strategic goals of the organisation. The frontline managers use operational information to ensure that specific tasks are planned and carried properly within the organisation.

3.2 Objectives of MIS

- Ensuring that all levels of management get the necessary information to carry out their managerial functions.
- Improving the processes of decision making in the organisation.
- Exposing members of an organisation to information technology (IT) through the use of computers to acquire and disseminate information as quickly as possible.
- Helping to establish accurate database at all levels to meet specific needs of the organisation.

3.3 Need for Management Information Systems

Management requires information for the following reasons:

- To establish, evaluate and adjust objective where necessary
- To develop and plan standard

- To measure actual performance so as to enable a comparison with plans and standards; and
- To provide a basis for informed communication.

3.4 Characteristics of MIS

- It is usually directed towards management of an organization, be it formal or informal.
- Data flow: MIS has common data flow
- Data form sources of input while information serves as output
- MIS depends highly on database
- MIS operates in areas of distributed data processing
- It creates room for other subsystems to exist.

3.5 The Design of MIS

Many factors come to mind when designing MIS. Some of these factors include:

- **Behavioral Factor:** Consists of the norms, attitudes, motivations, aspirations and capabilities of the people involved. For instance, in Nigeria MIS on compulsory levy in primary institutions might be jeopardized in some parts of the country because of their beliefs and attitudes.
- **Communication Channels:** In order to make information available where and when needed, seminars, meetings, retreats etc have to be organized.
- **Computer Facilities:** Computer and other data transmission should be made available to help in data processing.
- **Internet Facilities:** If possible, it is ideal to be on network so as to have access to important information when designing yours.
- **Personnel:** For effective data processing, competent personnel with qualitative computer knowledge might be needed to help in data processing.
- **Database:** Simple database might be maintained to help in analyzing information.

SELF ASSESSMENT EXERCISE

Explain to a novice certain factors to be considered in designing MIS.

3.6 Problems with MIS and Solutions to the Problems

Problems with MIS

Solutions to Problems of MIS

<p><i>Lack of Management Involvement:</i> Most often the design of MIS is left in the hands of information specialists who may not know enough about management. At times they do not appreciate management's true information requirements and of organizational problem.</p>	<p><u>Management should try to participate in the designing of MIS by giving the designers clues of what the organisation actual y needs.</u></p>
<p><i>Lack of Top Management Support:</i> Top management sometimes does not encourage MIS due to various reasons often based on fear of the unknown.</p>	<p>Top management may not want their decisions to be challenged; thereby adhering to the slogan "this is how we have been doing it". Top management should realize that the organization's success is mostly determined by the environmental factors; and it is information that wil allow you to cope and manage the ever-changing environment.</p>
<p><i>Lack of Computer Knowledge:</i> It is a glaring fact that most administrators at all levels of management have little or no computer knowledge. Therefore, it is always difficult for them to assist MIS designers to acquire and disseminate information.</p>	<p>Presently, among the best means of processing data, acquiring and processing information is the computer. Since computer is the major tool of information technology, al staff should try to have computer knowledge in order to help in achieving the success of MIS.</p>
<p><i>Inappropriate Emphasis of Computer System:</i> In some organisation too much emphasis is laid on the use of computer to the extent that other methods of information acquisition and dissemination are relegated to the background.</p>	<p>Although, computers can assist in acquiring and disseminate information as quickly as possible, there are still limitations. Computer cannot be employed to know the behavioral factors, but it can be used to analyze the result in any form. In Nigeria, for example, the attitude toward Western education in both Northern and Western parts cannot be known by using the computer but the information can be analyzed with the computer.</p>

3.7 Issues Addressed by Management Information System in Education

The aim and objectives of an educational institution and the number of activities in each institution will determine the type of management information systems to be developed or adopted for that institution. Within each functional area, the head requires constant flow of information in decision making and discharge their duties without any delay. Management information system therefore, is essentially the most crucial connecting link between the various management departments, functions or unit in any educational institution.

Efforts to develop a good Management Information System for educational institutions give education manager the opportunity to assess the following set of crucial educational question:

- What are the objectives of the educational system or the institution and what are the various functions and activities related to each of them?
- What is the nature of the outcome or result expected from the activities? Is the educational institution working in a way to ensure good result?
- What is the plan for the short/long term? Is the plan usable? Will the current plan meet the present / future need of the student and the society?
- What are the facilities available for the execution of the programmes? Are these facilities adequate? and
- Are the existing operational budgets at the different level sufficient to cover the organization functions anticipated?

3.8 Technology for Management Reform

With the introduction of Management Information Systems in Education in the school curricular, the education managers now adopt Management Information Technology in their day-to-day activities. The technology brings about reforms in the following areas of the institution.

3.8.1 Management of Institutions and Systems

The same technology used in computing and telecommunications services that brings about business efficiency, cost-effectiveness can also be applied to schools/school systems to enable the school head to streamline operations, monitor performance and improve on the utilization of resources. Technology also promotes flow of information among schools, parents, communities' central decision-makers and

business and fosters greater accountability and connectivity with the market place.

At the school/institutional level, technologies are crucial in such areas as students' admissions, students flow, personnel, staff development and facilities.

3.8.2 Management of Policy Making

The process of policy analysis and development is a complex and strategic one. It is by necessity, an intricate, non-linear process in which a variety of people and institutions with different view are actively involved in the process of analyzing, generating, implementing, assessing, adjusting and re-designing policies. At this point, information can be valuable in storing and analyzing data on education indications, students' assessment, physical and human infrastructure, cost and finance etc. Technology can assist in constructing scenarios around different intended policy options to determine requirement and consequences. Each scenario can then be analyzed systematically, evaluated in terms of accessibility over a period of time to have results. Technology can facilitate tracer studies, tracking systems as well and summative as formative evaluation during policy implementation.

3.8.3 Managing of Learning Activities

Technology is also a powerful instrument in driving and managing new modes of instruction, where distance is no barrier to learning, and more students' interactions, more connections among/between schools, more collaboration among learners, and more involvement of tutorial facilitators. These needs are more critical in self-study; distance education and many platforms have been developed to meet such needs. Technology should not be a solution looking for a problem, it needs to be preceded by needs assessment, market analysis, strategic plan and experimentation, and accompanied by training appropriate investment and maintenance.

3.9 Institutional Goals of Management Information Systems

Management information system for an institution should be designed to achieve the following goals.

- Enhance communication among staff.
- Deliver complex materials throughout the institution.
- Provide objective system for recording and aggregating information.
- Reduce expenses related to labour-intensive manual activities.
- Support the organizations strategies goals and direction.

Management information system in Education supplies education decision makers with facts, it supports and enhances the overall decision making process and also enhances job performance throughout an institution. At the management level, it provides information that helps the board of management (i.e. the highest decision making body for the institution), to make strategic decisions for the institution.

Management information systems address the effective use of human and computer resources available in an organization to achieve the objective of the organization. The professionals in the field of management information systems are responsible for developing various information systems that provide accurate and timely information to all levels of decision-making in an organization.

3.10 The Role of Management Information System on the Behaviour of Educational Managers

All over the world, it is an established fact that information technology has been influencing the behaviour of educational managers in their daily discharge of their duties. But there is not yet an agreement about the precise nature of the change especially in educational institution. However, the application of management information system has, certainly reduced the tedium of administrative decision-making matters at both the lower and middle levels of management. In an educational institution, where computer-based management information system is used, it was clear that the heads of departments, principals, chief executives, registrar etc, have found decision making easier with management information systems.

In Colleges of Education, Polytechnics and Universities, the usual areas of information difficulties are budgeting, students' records, staff placements, audit and accounts, salaries, purchasing and supply, examination and results etc. But with management information systems in education, all these and other areas of difficulty are handled effectively and efficiently.

There are two schools of thought according to Nwankwo (1985) in the controversy over the role of management information system on educational managers. One school holds that, the use of computers would facilitate the jobs done at the clerical, technical and administrative level. As a result of this, fewer middle level and lower level management and non-academic staff would be needed. This means that some of the staff in these categories will be rendered redundant.

The other school of thought argues that since top management frequently depend on middle and lower levels for information, the behaviour of top managers will positively improve with the use of management information systems towards greater efficiency and more accurate decisions. For example, a research carried out by Hofer (1970) showed that the development of management information system has assisted top managers in industry and education to:

- Make some decisions at an earlier date
- Gain time in which to consider some decisions
- Consider more through analysis of some situations
- Review several courses of action of many problems
- Obtain additional information from middle managers concerning problems, opportunities and promising alternatives before making decisions.

3.11 Challenges of Management Information Systems in Education

The technical element about MIS in education is how to use information. Making use of information is highly specific, often personalized activity that affects work habits, work style, and the flow of work. Since the use of information is highly specific, training and re-training, refreshing, workshops, seminars are necessary instrument in making MIS in education effective. Many obsolete styles of information system have failed not because of being obsolete, but because the operations failed to change with them or refuse to maintain them. MIS in education involves several critical steps to success which are listed below:

- i. Set standards for information: As a major requirement for MIS in education, needed information must be generated, defined and described.
- ii. Set Timing: Information generated at different times and location will vary because of the time and location. The figure obtained for enrolment rate in September may be different from the one obtained in March because of the time lag. Likewise, the rate obtained from the cities/urban centers may be different from the one obtained from rural areas.
- iii. Define the level of possible accuracy. Most systems (statistics, personnel, inventory, textbook, examination) except finance, cannot report with more than 2-3% accuracy simply because of delays.

- iv. Reports should be the result of daily activities not special purpose efforts as much as possible. All reporting should be extracted from daily operational activities. For example, data on enrolment should be generated from school registers.
- v. Define formats – This should be done at the early stage of design so that people can get used to it and know how to present and interpret information. For example if there is enrollment data for the nation, MIS in education must be ready to give additional information at regional / zonal or state level and also provide additional information on which analysis could be based.
- vi. Ensure prompt feedback – information provider must be given results of their work as quickly as possible because, the closer/quicker the processing of information is to the source, the better the level of accuracy and reliability.
- vii. Quantify the cost of producing information – Most institutions, ministries, parastatals produce information any how, they in no way measure the cost of the information in monetary terms.

4.0 CONCLUSION

In general MIS may be seen as a data processing system, which provides information to management for the purpose of controlling the business and as a basis for making decision.

The information generated and obtained by management information systems in education is not only geared towards producing the annual statistical yearbooks of the Ministry of Education, nor allocating extra work for the Planning, Research and Development unit of the Ministry, it is a potent instrument for effective capacity building and a bridge to donor intervention and support in improving how to achieve educational objectives.

5.0 SUMMARY

In this unit, you have learnt about the inherent problems with MIS and the possible solutions to such problems as well as the various challenges of MIS in education.

6.0 TUTOR-MARKED ASSIGNMENT

1. Define MIS and outline the objectives of MIS in education.
2. What are the main challenges to the success of MIS in education in Nigeria?

7.0 REFERENCES/FURTHER READINGS

Nwakwo, J.I (1985). *Fundamentals of Management Information System*, Association of Book-makers Nig. Ltd. Ibadan: Nigeria.

Hussain, K.M (1973). *Development of Information System for Education*, Engle wood cliffs: New Jersey: Prentice Hall.

G. A. Cole (May 1986). *Management Theory and Practices*, Second Edition.

UNIT 3 INFORMATION TECHNOLOGY (IT) AND MIS IN EDUCATION

CONTENTS

- 1.0 Introduction
- 2.0 Objectives
- 3.0 Main Content
 - 3.1 Definition of Information Technology
 - 3.2 Application of IT in Information Systems
 - 3.2.1 Office Support
 - 3.2.2 Distributed Data Processing or Transaction Processing
 - 3.2.3 End User Computing
- 4.0 Conclusion
- 5.0 Summary
- 6.0 Tutor-Marked Assignment
- 7.0 References/Further Readings

1.0 INTRODUCTION

This unit will assist you in understanding the relationships that exist between Information Technology (IT) and Management Information Systems (MIS) in Education, particularly, in the areas of application of IT in information systems.

2.0 OBJECTIVES

By the end of this unit, you will be able to:

- define Information Technology (IT)
- explain application of IT in Information Management.

3.0 MAIN CONTENT

3.1 Definition of Information Technology

As it has been defined earlier on in Module 1, Unit 1, Information Technology is the technology, which supports the activities involving the creation, storage, manipulation, and communication of information with their related methods, management and applications. Cole (1956) supplied a useful definition given by the Department of Trade and Industry in Britain as follows:

The acquisition, processing, storage and dissemination of vocal, pictorial textual and numeric information by a micro-electronic based combination, of computing and telecommunications.

In short, IT is the medium by which information is passed across to all levels of management either internally or from external sources. Some of the IT facilities include computers of various types, scanners, printers, servers, word processors, photocopiers etc and other devices for information acquisition and dissemination such as Teleconferencing/Videoconferencing, Networks, Teletext, Facsimile, Internet, E-mail, and Voice Mail etc. As you may notice, some of them have been discussed under acquisition and dissemination of information

3.2 Application of IT in Information Systems

Even though it is difficult to demarcate IT from MIS, it is possible to outline three major areas of IT application in information system. The three areas are:

- office support systems;
- data processing (or transaction processing); and
- end user computing.

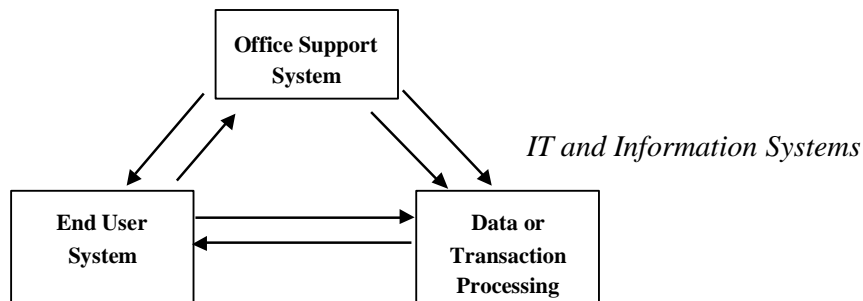

As you can see from the figure above, the three major areas of IT application in information systems are inter-related.

Note that IT is discussed here in relation to the scope of this course.

Other areas such as scientific use of IT, computer aided design and manufacture (CAD/CAM), robotics etc are out of scope of this course.

3.2.1 Office Support

The type of office supports used influences information available for management. In modern offices, there are systems that help to facilitate the acquisition and dissemination of information at various levels of management. The office support systems we are referring to here, are microelectronics and telecommunication devices. Some of them are

discussed below and others such as Networks, Internet and E-mail are discussed separately in different units because of their importance to our course of study.

Text Handling Facilities: Word Processors e.g. micro computers and other text handling facilities such as photocopiers, printers,, scanners etc are common features in modern offices, Word processor enables you to typeset documents, edit and give them the necessary formats. The documents can be stored in back-up storage media to be retrieved as at when due or printed out as many times as possible through the printer.

Photocopiers: A photocopier machine makes duplicates of information in form of texts, charts, auto shapes, pictures etc. Indeed, it has become in-house miniature printing system for printing reports, memos, booklet bulletins and other documents.

Desk-Top Publishing (DTP): Many softwares have been developed to handle processing of words and graphics in addition to the capabilities of importing/exporting from/to other application programmes. Examples of such applications are: Corel draw, Adobe page- maker etc. Also, cameras and scanners can be used to send pictures and other graphics. Hence professional quality reports, bulletins, memos, books and other documentations can be produced within the office.

Data Storage, Retrieval and Referencing: One of the major benefits of IT in office support, is the possibility of storing large amounts of data that could be accessed at any time with minimal effort. Files are stored in computer hard disc or in other auxiliary storage medium (Floppy discs and compact discs), and can be accessed using any type of computer with a VDU. However, if there is need for repeated referencing to information, in visual form, **Computer Output on Microforms** can be used. Microforms are photographically reduced information on files.

Teletext/Viewdata: Teletext is a system for disseminating commercial and other information through available television network. It is also a referencing facility. On the other hand, view data is similar to Teletext because it also provides electronic referencing to materials but it is different in the sense that:

- i) It is available only to subscribers who pay subscription as arranged e.g. DSTV.
- ii) It is interactive in nature since user can interrogate the data supplied to the system and also supply answers to it unlike Teletext which is for reading only.

A good example of viewdata is seen in a system in which information provided by airlines can be accessed by travel agents to check flight times and availabilities and to book seats.

Telecommunications Devices and Facilities: some telecommunication devices such as voice mail, facsimile, teleconferencing and video conferencing have been discussed exhaustively under acquisition and dissemination of information. Others such as Networks, internet and e-mail as said earlier on are discussed separately in other units, because of their importance in Management information systems in Education.

Data transmission: is a situation whereby data and speech can be transmitted over ordinary telegraph and telephone circuits. Transmission of data is possible in three ways:

- i) **Simplex:** is a situation whereby transmission is possible in one direction only.
- ii) **Half Duplex:** is a situation whereby transmission is possible in
- iii) **Duplex:** Is a situation whereby transmission is possible in both directions simultaneously.

Electronic Data Interchange (EDI): it is a form of electronic mail because it allows computer interchange of data. The system allows computers of different organisations to communicate thereby replacing traditional paper based communication through orders, invoices etc. Some of the specialized applications of EDI are:

- i) **Electronic Fund Transfer (EFT):** It involves using the computer to send electronic data to a bank giving instructions to make payments or to transfer money between accounts. It is often employed to pay suppliers and worker's salaries.
- ii) **Society For Worldwide Interbank Financial Telecommunication (SWIFT):** It allows the use of security codes for international trade operations involving foreign currencies worldwide, The Electronic fund transfer system between financial institutions in Nigeria is called: Nigeria Interbank Settlement System (NIBSS).

SELF ASSESSMENT EXERCISE 1

Define Data Transmission. Differentiate between Half Duplex and Duplex under data transmission.

3.2.2 Distributed Data Processing or Transaction Processing

After office support the next application area of IT is the aspect of repetitive processing of daily transactions of the organisation. In truth, some applications need to have data kept up to date all the time. These systems use direct access files in which any record can be read or written without having to read or write all the records before in the file. Transaction processing systems were among the first to prove the importance of the computer and originally were based on centralized mainframe computers to process large volume of routine jobs. However, with the advent of micro computers (desk tops, lap tops palmtops and note book) transaction processing has become so popular. Transaction processing makes it possible for data handling and processing to be carried out at or near the point of user rather than in one centralized location. Transaction processing is essential to keep the operations of the organisation running smoothly and provides the base for all other internal information support.

Typically, transaction processing is seen in areas of order handling, accounts receivables and payables, invoicing, credit control, stock movements etc. More also, transaction processing is vivid in library loans system and students examination records.

3.2.3 End User Computing

Previously, it was believed that computer application is meant for those professionals such as programmers, system analyst etc., who have computer knowledge in related fields. However, with the evolution of personal computers, database networks and other application programs, this belief has been relegated to the background since managers can now develop their own systems to solve a particular problem and also to support and aid their processes of control and decision-making. Lucey (1997), defined End User computing as:

The direct hands-on approach to computers by users - not indirect use through systems professionals. Users include managers, office staff, sales people, production workers and others.

There are many applications to end user computing, but we shall concentrate on three that are related to our study.

Decision Support Systems (DSS): The essence of DSS is to support managers in their daily activities, especially decision making. It is quite similar to office support, but in DSS the managers, (i.e., the user) use variety of tools and procedures to develop their own system to help perform its functions more effective. It is this active involvement and

the focus on decision-making, which distinguish a DSS from data processing system. This will be seen clearly under Spreadsheet management (Excel) later. Some of the packages you can employ for decision-making support are: Forecasting, Spreadsheets, Modeling and simulation, Non-linear programming, Expert system etc. However, spreadsheet, using Ms-Excel is discussed in details in module 2 and 3

Expert System: It is a knowledge based system, which is a network of rules that represent the human expertise. It is a computer system, which encompasses some of the experience and specialized knowledge of an expert. In other words, an expert system allows a non-expert to achieve comparable performance as an expert in the particular field. However, the user does not surrender his judgment but he uses the system to enhance his judgment. Some of the fields that have witnessed the use of expert systems are: Medical diagnosis, personal tax planning, aircrew scheduling, credit approval in banking, geological explorations etc.

Executive Information System (EIS): This is another application tool under end user computing. EIS is a form of data retrieval system that provides selected and summarized information for senior management members. It facilitates the provision of information on critical areas of the organisation activities drawn from both internal and external databases.

An EIS should exhibit the following characteristics:

Easy to use: It must not be ambiguous. It must be simple and fast. And to guarantee the simplicity, the use of touch screen, pop-up menus, mouse etc. are approved.

Access to data: data must be accessed without any hitch or hindrance, thereby permitting vertical and horizontal exploration of data. This is known as drilling down the data.

Quality presentation: The report must be presented in attractive and understandable formats using graphics, charts, colours, diagrams etc. of high quality.

SELF ASSESSMENT EXERCISE 2

What are the features of Executive Information System (EIS)?

4.0 CONCLUSION

Office support systems cover different types of aids including: word processing, electronic mail, data transmission etc. Electronic data transmission is supplementing traditionally based communication.

5.0 SUMMARY

The main areas of IT application in MIS are: data processing, office support systems and decision support systems.

6.0 TUTOR-MARKED ASSIGNMENT

Explain the following terms under Office Support:

- a) Text handling facilities
- b) Desk-top Publishing

7.0 REFERENCES/FURTHER READINGS

Lucey T. (1997). *Management Information Systems*, 8th Edition
Ashford Colour Press: Gosport Hampshire.

Cole, G. A. (1986). *Management Theory and Practices*, 2nd Edition.

**UNIT 4 IT AND MIS IN EDUCATION: COMPUTER
APPRECIATION****CONTENTS**

- 1.0 Introduction
- 2.0 Objectives
- 3.0 Main Content
 - 3.1 What is a Computer?
 - 3.2 Classification of Computers
 - 3.2.1 Classification of Computers by Type
 - 3.2.2 Classification by Size/Capacity
 - 3.2.3 Classification by Nature of Location
 - 3.3 Computer System
 - 3.4 Structure or Layout of a Computer System
 - 3.5 Computer Component and Configuration
- 4.0 Conclusion
- 5.0 Summary
- 6.0 Tutor-Marked Assignment
- 7.0 References/Further Readings

1.0 INTRODUCTION

Although it is quite obvious that the computer is not everything about MIS, yet it is the basic tool we can easily employ nowadays. And it is an uphill task for someone to discuss other means (Networks, Internet and E-mail) of information technology (IT), or other application programmes, which are necessary for this course, without creating basic knowledge of computing.

Note that this aspect of the course is not to make you a computer scientist, rather, to create an understanding of the basic elements which make up the computer system, which is at the heart of EDP; and to know how management can best use the computer and other IT equipment to provide better information.

In addition, knowledge about computer appreciation will make you to be familiar with some common computer terms or languages that may interest you during your studies.

2.0 OBJECTIVES

At the end of this unit you should be able to:

- describe what a computer is
- classify computers based on type, size/capacity, and nature of location
- learn what the computer system is
- understand the structure or layout of a computer
- explain the components and configuration of a computer both Hardware and Software.

3.0 MAIN CONTENT

3.1 What is a Computer?

A computer is an electronic machine, which is capable of storing data, performing computation on such data and retrieving information at a very high speed. The computations that can be performed include addition, subtraction, multiplication, division, etc. Computers can also compare two or more values to check for such logical relationship such as greater than, less than etc.

In summary, a computer is an electronic machine or device that accepts data as input, processes the data, and gives out useful information as output. (*See Unit 1 for notes on Data and information.*)

3.2 Classification of Computers

Computers are grouped into various classes depending on the character they exhibit, the way they look or the way they are located.

Subsequently, one computer can be referred to as digital computer and also mini computer.

3.2.1 Classification of Computers by Type

Under the classification of computer types, computers are classified into three groups namely: analogue, digital and hybrid.

Analogue Computers: This is a computer which does not compute directly with discrete values (digits), rather it measures quantity in continuous flow e.g. temperature, current, voltage.

In other words, they are computers that work on physical principles or properties.

Examples of such computers are diagnosis, thermometer, barometer, anemometer, analog watch etc.

Digital Computers: Digital computer unlike analogue cannot measure quantity in continuous flow. It measures discrete values such as digits (0-9), letter of the alphabet, A to Z and special characters such as \$, #, &. They are the computers that understand binary (0 or 1) which can also represent an open or closed circuit in its electronic circuits. They work on discrete electrical state, such as **ON** or **Off** and discrete signal. Examples of such computers are: calculators, gaming computers, desktops, laptops etc.

Hybrid Computers: This system has the features or capabilities of the analogue and digital computers. It can measure quantity in continuous flow as well as those in discrete values. The system used in the electricity meter reading is hybrid. It converts the quantity of the flow of current into digits, which can later be converted into monetary values such as naira or dollars.

SELF ASSESSMENT EXERCISE 1

Outline and explain the classification of computers by type.

3.2.2 Classification by Size/Capacity

In the classification of computer by size and capacity, computers are classified into various groups namely: mainframe, mini and micro-computer.

Mainframe Computers: Mainframe computers are the largest forms of computers. These are computers that are very bulky and are usually stored in control rooms with air-conditioning accommodation. The CPU of the mainframe computer is the only element that distinguishes it from other forms of computers. The CPU is greater in size than the others and in fact more complex. It consists of many chips, i.e. processors connected together on several boards.

It also has the capability of allowing other computers or terminals located at remote sites to communicate with it.

Mainframe computers are used in research institute where they supply general purpose computing facilities and in commercial organisation like banks where large amount of transactions are made. Examples are: IBM 370, ICI 900 etc

Mini Computers: Mini computers are smaller in size when compared with the mainframe. but can perform the same arithmetic and logic operational functions. Like mainframes, they also require air-conditioning facilities

Mini computers are very suitable for processing tasks that do not require considerable access to large masses of stored data. Examples are: Vax series, PDP-8 etc.

Micro-Computers: The Micro-computer is the smallest form of computers. This computer makes use of microprocessor as its central processing unit (CPU). The Micro-computer is the easiest to use and least expensive. Many individuals purchase micro-computers for personal use, either for their jobs or for other purposes. Thus, micros are also known as Personal Computers (PC). They are those computers that are seen in almost every office today. Everything about them, such as heat produced, storage capacity, types of data processed, connected devices, processing rate, size, efficiency, power consumed etc. are relatively moderate.

Micro computers by comparison with mainframe and mini computers, are altogether smaller and lighter, and do not require any special environment. Examples are: Desktop, Laptop, Notebook and Palmtop of various series.

3.2.3 Classification by Nature of Location

Computers are also classified by the way they are located or where they are located in other devices; and in this class, is the embedded computers.

Embedded Computers: These are computers that are located within other machines to make them act like computer e.g. Speedometer.

3.3 Computer System

A simple computer system consists of the computer itself and other hardware devices, which are attached to the computer. We usually call these extra devices peripherals or supporting devices. The figure (below) shows a typical micro-computer system.

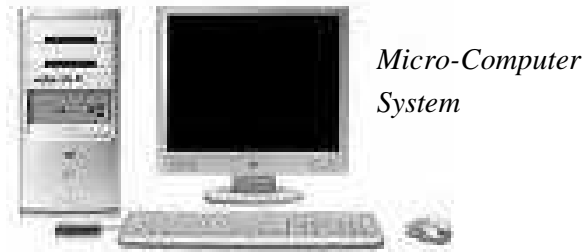

3.4 Structure or Layout of a Computer System

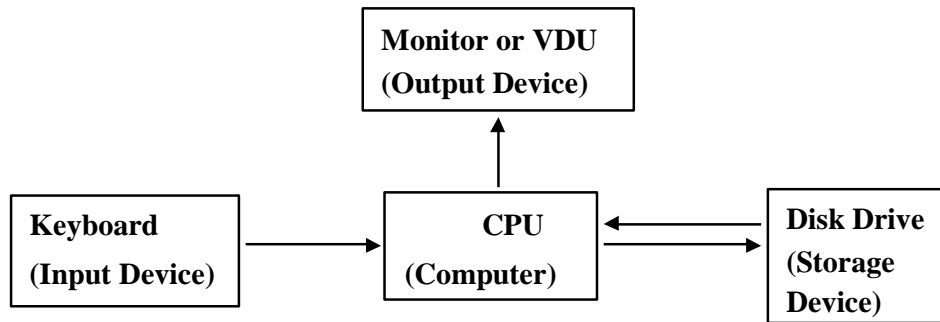

The block diagram above shows the layout of a microcomputer system. As depicted in the diagram, the CPU is attached to a VDU (screen) so that output can be displayed. It is attached to a keyboard so the user can type in instructions and data. It is also attached to a disk drive, which is used to store data and programs on magnetic disk.

Notice the direction of the arrows on the diagram. These arrows show the direction of data movement. Data move out of the computer to the screen so we call the VDU (screen) an **output device**. Data move from the keyboard into the computer so we call the keyboard an **input device**. The disk drive in the diagram is connected by two arrows, one in each direction. Data can move from the computer to the disk drive and also from the disk drive to the computer. The disk is a **storage device**.

3.5 Computer Component and Configuration

The computer consists of vital resources or components, which are very essential for information processing. For convenience sake, the component may be divided into two main categories namely, **Hardware** and **Software**

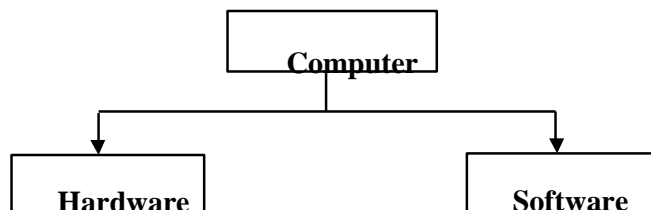

4.0 CONCLUSION

The computer is a tool to many people in different ways. Therefore, we define the computer in such ways that can let us know completely what it is. Also, computers are grouped into various classes depending on the character they exhibit, the way they look or where they are located. Subsequently, one computer can be referred to as digital computer and also mini computer. Another can be called embedded computer and at the same time called special purpose computer.

5.0 SUMMARY

Within business organisations, many different types and sizes of computer systems are found. Usually, the appropriate system is determined by the range and volume of services required to conduct the business. Big organisations rely on central mainframe computers, with mini computers and microcomputer servicing local and individual needs. Within medium sized organisations, a mini computer is usually sufficient to handle transaction processing. Within small business organization; one or more micro-computers usually support both company work and individual processing needs.

6.0 TUTOR-MARKED ASSIGNMENT

1. What is a computer?
2. Classification of computers can be done based on the size or capacity of the computer. Discuss.

7.0 REFERENCES/FURTHER READINGS

- Bidmos, F. (2004). *Understanding Computer Applications and Management Information Systems*, Panaf Press: Lagos, Nigeria.
- Petroleum Training Institute (PTI) (1999). *Lecture Manual on Computer Appreciation*, Warri.

**UNIT 5 COMPUTER APPRECIATION CONTINUED:
HARDWARE AND SOFTWARE****CONTENTS**

- 1.0 Introduction
- 2.0 Objectives
- 3.0 Main Content
 - 3.1 Hardware
 - 3.1.1 Input Units (Devices)
 - 3.1.2 Central Processing Unit (CPU)
 - 3.1.3 Output Unit
 - 3.1.4 Storage Device (Unit)
 - 3.1.5 System Unit
 - 3.1.6 Parts of a Computer
 - 3.2 Software
 - 3.2.1 System Software
 - 3.2.2 Application Software
 - 3.3 Computer Virus
 - 3.4 Booting
 - 3.5 Shut Down/Turn Off Command
- 4.0 Conclusion
- 5.0 Summary
- 6.0 Tutor-Marked Assignment
- 7.0 References/Further Readings

1.0 INTRODUCTION

In this unit, you will learn the various parts that make up a computer system. You will also learn about the hardware, the input unit, the output unit, central processing unit and the storage unit of a computer system as well as external devices used by a computer such as diskettes, compact disk, zip disk and flash drive.

2.0 OBJECTIVES

At the end of this unit, you should be able to:

- define computer hardware and software
- explain the various parts of the computer that make up the hardware and software
- understand the meaning of Computer Virus
- understand what is meant by Booting
- understand how to shut down the computer.

3.0 MAIN CONTENT

3.1 Hardware

This includes all equipment or physical devices used in processing data and delivering information. Hardware encompasses everything that is tangible, be it mechanical or electrical in a computer. It is any part of computer system that can be seen, touched and felt. Examples are keyboard, monitor or console, printer, scanner, plotter, fan processor, power pack, speakers, card, mouse, UPS etc.

Hardware can belong to any unit such as the input unit, central processing unit (CPU), output unit, storage unit or any part such as the main parts and peripheral parts of the computer. Some of them are explained below:

3.1.1 Input Units (Devices)

Input devices are used to put data into the computer. In other words, they are the units you can use to talk to the computer. The input devices capture data and make then available for processing. In synopsis, the input devices are devices meant for collecting data from the outside for the computer to process.

Input devices could be categorized into two – operated input devices and automated input devices.

Operated Input Devices: Allow data to be entered into the computer by the use of hand. Examples of operated input devices are: keyboard, mouse, microphone, joy-stick, scanner, punching machine, touch screen, sorter, collator, graphic tablet or digitiser, digital camera, video digitiser etc,

Automated Input Devices: Allow automatic data entry to take place. Examples of automated input devices are: optical mark recognition (OMR), optical character recognition (OCR), magnetic ink character recognition (MICR), sensors, smart cards, magnetic strip codes etc.

Some of the input devices are explained below:

- i) **Mouse:** The mouse is a pointing device that is moved around on top of a mouse pad/mat or desk to move a marker called a **cursor** around the screen. In other words, a mouse is a hand-held device that controls the movement of a pointer on the screen. With the mouse, you can draw, move objects select commands and play

games. Some mouse have cable (cord) to connect them to the CPU while some are cordless.

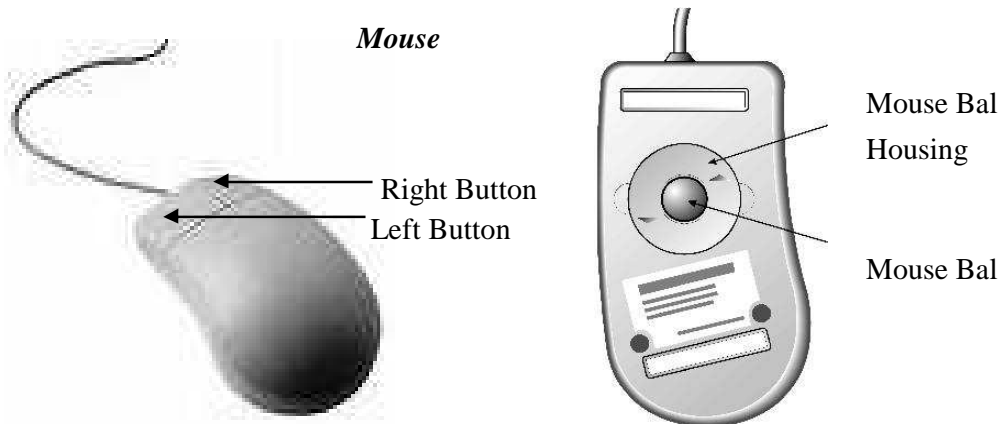

See more notes on how to use the mouse in Module 2

- ii) **Keyboard:** The computer keyboard looks like a typewriter keyboard. It is used to type in command, instruction, data or whatever we want to send into the computer. Hence it is a communication device between the user and the computer. The keyboard is referred to as **command line interface**. This is because it enables the user to give command to the computer using its keys. Like mouse, some keyboards are cordless (without cable) while some have cord (cable) that connects them to the CPU.

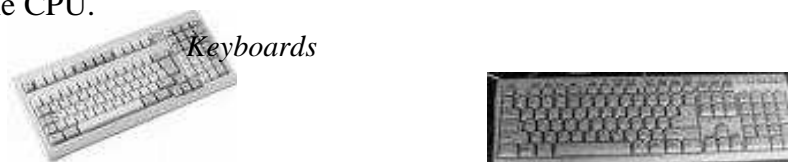

See more notes on how to use the Keyboard in Module 2

- iii) **Scanner:** The scanner is a machine that is used to collect data about the light reflected by areas on a picture and transmit it to the computer in order to reproduce or record photographs and other document into the computer. The scanner has features of a photocopying machine; therefore it can be used to reproduce documents. Once you have scanned the picture you can edit the computer version, cut bits of it, or rescale as required. Scanners can work in black, white, and grey or colour.



Scanner can also be used to input pages of text. However, optical character reading software is needed to convert the graphics image of the text into a text file, which can be edited using a word-processor.

iv) Optical Mark Recognition (OMR): The OMR is a technique, which involves the reading of documents, or forms that are shaded usually with HB pencils. An optical mark recognition scanner such as the one above scans these documents and information therein is read by a computer system, which is connected to the scanner. All the printing on the form is in very pale ink called **fade-out ink**. This ink is not detected by the reading machine, which detects only a shaded portion. The machine transmits data about each space to the computer and the software works out whether the answers are right or wrong and adds up the total mark.

The form will not go through the machine if it has been folded or wrongly handled. Other forms cannot be read because they have got dirty or marks have been made in the wrong place. The data from these rejected forms have to be entered by hand.

OMR is used in the conduct of examinations.

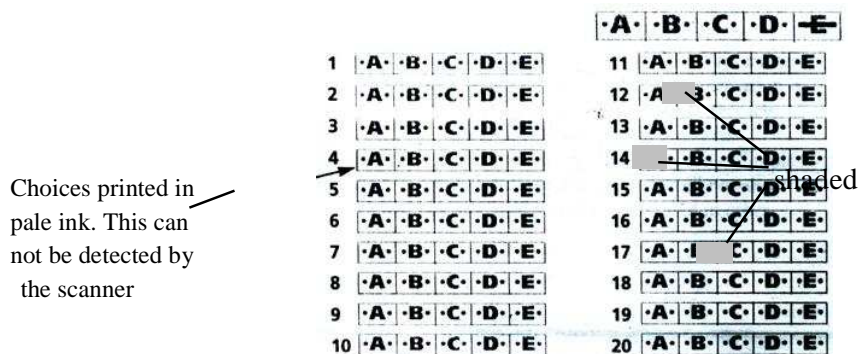

A multiple choice card used in examinations

SELF ASSESSMENT EXERCISE 1

Write short notes on any two operated input devices known to you.

3.1.2 Central Processing Unit (CPU)

The CPU also known as the processor or micro processor was first developed by Intel in 1974. The CPU is responsible for handling all instructions and calculations it receives from other hardware components in the computer and software programs running on the computer.

The CPU is often referred to as the heart, brain or life wire of the computer, where the actual arithmetic and logical operations are carried out. It contains the electronic circuitry that performs the arithmetic and logical operation required for data processing. The CPU is composed of three functional parts, as shown in the chart below:

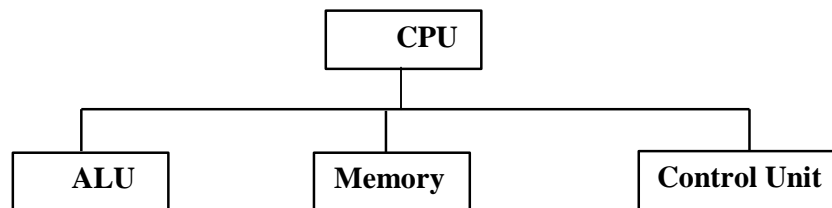

- i) **Memory:** The computer memory is the storage place where the computer keeps data and information that are to be worked on. The memory is further divided into two different layouts – **RAM** and **ROM**.
 - a) **RAM (Random Access Memory):** It is a workplace of the computer. In other words, it is a storage area that holds programs and data temporarily during processing. Programmes are stored in the RAM until processing is completed. RAM is volatile which means that it can only hold data and information when there is power failure. The capacity of the computer's RAM determines the speed of the computer during processing of data.
 - b) **ROM (Read Only Memory):** Unlike RAM, the ROM is non-volatile, which implies that it is not affected by any power failure and it can hold information permanently.

Some of the functions of ROM include:

1. Rom is used to hold instructions which are needed to start up the computer.
2. It contains the system manufacturer's information.

3. It performs **Power-on-Self-Test (POST)** functions. This has to do with self-test of the internal circuitry and peripheral devices attached to the computer.
4. It performs **Basic-Input-Output system (BIOS)** function. The ROM contains some routines that stand as fluids boundaries between the different peripheral devices that make up the computer to work as integrated unit (system).

Note: The major differences between ROM and RAM are:

1. RAM is volatile while ROM is non-volatile.
2. Information in ROM is permanent while that of RAM is temporal.

SELF ASSESSMENT EXERCISE 2

What is the full meaning of RAM and ROM?

- ii) **Arithmetic and Logical Unit (ALU):** Arithmetic unit performs such processing operations, which involve addition, subtraction, multiplication division etc, while the logic unit performs the function of comparison between numbers and shifting of value from one area to another. After the control unit has set up the necessary path, data are brought from memory to the ALU and placed in registers. Within these registers, arithmetic and comparison operations are performed.
- iii) **Control Unit:** This directs the operations of the computer by interpreting programs instruction and activating the circuitry to carry out the instruction. When the user inputs programmes, then the control unit recalls programme instructions one at a time as needed, evaluates each instruction to determine what operation is required, and activate the electronic circuitry and data path necessary to carry out the operation.

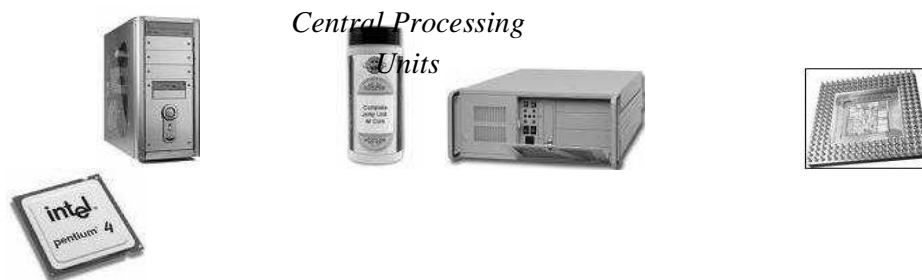

3.1.3 Output Unit

These devices are means of communicating the processed task in the computer to the user. In other words, they are the devices used to get information out of the computer system in a form, which the user can understand. During output the data is put into a context so that it becomes information. Examples are: visual display unit (VDU) or monitor, printer, speaker, Graph plotter etc.

- i) **Monitor:** The monitor is also known as visual display unit (VDU) or display screen. The monitor looks like a television. It shows what the computer is doing or the work/ task that the CPU is processing. The flat screen sharply reduces reflection from the user's environment and eliminates glare.

The monitor produces soft copy output because it is intangible; hence you cannot hold it or wipe it off.

Monitors



- ii) **Printer:** Printers are very important output devices that make it possible to print out (write out) work done on the computer.

Most system requires printed output like payroll and management information etc. According to the type of computer in use a large range of printer and printing systems are available. The printer takes information from the CPU in binary coded form then converts it to the form that is understandable to human before printing them on paper in form of hard copy.

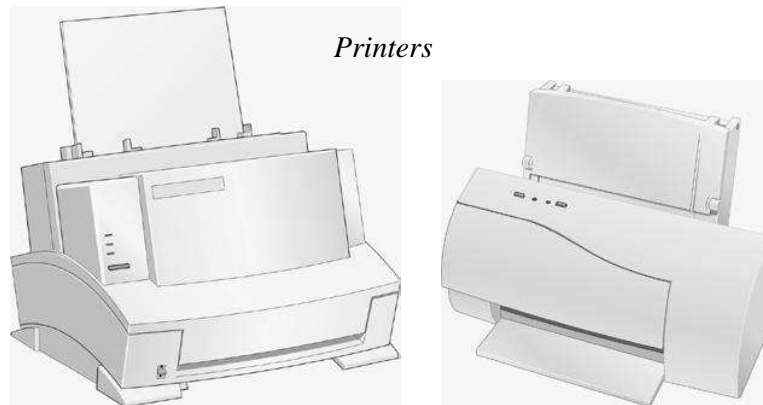

SELF ASSESSMENT EXERCISE 3

Mention any two (2) output units and explain one

3.1.4 Storage Device (Unit)

Data fed into computer systems have to be transferred to backing store so that it will not be lost when the computer is switched off or develops a fault. Backing store is the general name given to disks and tape used to store data. It allows data to be saved on a suitable medium so that it can be reused. The medium is the **disk** or **tape** on which the data is stored. The storage device is the **disk drive** or **tape drive** which reads and writes the data.

Drive: A drive is storage medium in the computer. It is any letter from A-Z or number from, 0-9 with a colon in front of it e.g. **A:**, **B:**, **T:**, **0:**, **6:**, **9:**, etc.

However, conventionally the common drives are labeled as follows:

Hard Disk	—————>	C i.e. C:
Compact Disk (CD)	—————>	Drive D i.e. D:
Floppy Disk (Diskette)	—————>	Drive A or B i.e. A: or B: as the case may be if there are master and slave and on the same computer.
Zip Disk	—————>	Drive E i.e. E:

Some of the storages devices are as follows:

1. Magnetic Disk (Hard Disk and Floppy Disk)

- i) **Hard Disks:** Are made of metal coated with a magnetisable material. They can hold a large amount of data and they are usually fixed inside the hard disk drive. The heads which move across the disk to read and write the data are extremely close to

the surface and a speck of dust can easily cause damage; hence the disk is sealed inside to keep it clean.

Hard disk capacities are measured in millions and billions of bytes of storage. They are in sizes of 1.2 GB, 2 GB, 4 GB, 40 GB etc. Hard disk drive is called **drive C**.

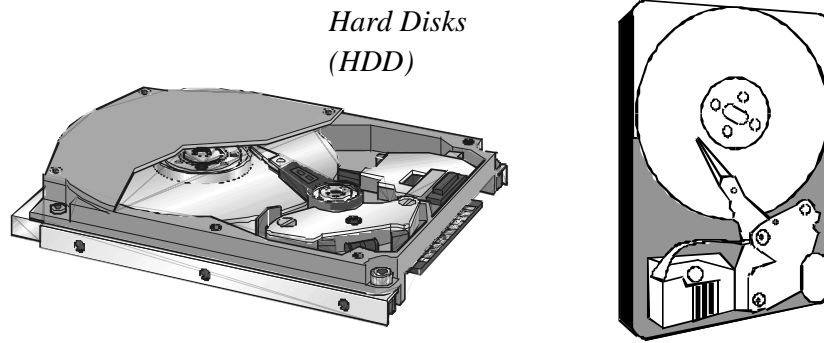

- ii) **Floppy Disks:** These are thin, flexible and made of plastic coated with a magnetisable material. They are sealed into a protective case which has openings to allow data to be written and read. They are also known as diskettes. Floppy disk is a secondary storage device, with a lesser capacity and it is detachable.

The floppy disk is labeled as **Drive A**. However some computers have two floppy disk drives – 3.5" (3½") and 5.25" (5¼") In that instance, 3.5" (3½") that always come with the computer will be **Drive A** while the other will be **Drive B**. Drive A is the **master drive** and Drive B is the **slave drive**. Presently, drive B is considered outdated because new model systems do not have provision for it.

*Note: when the diskette **Notch** is closed (protected), it becomes readable only, and you cannot copy on it; and while it is opened, it becomes both readable and writeable and that means you can copy on it.*

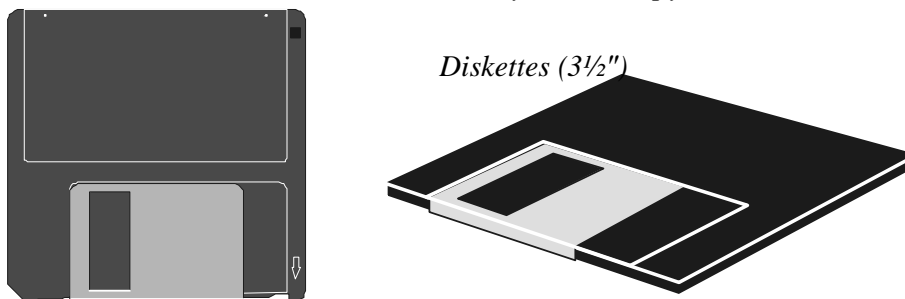

2. Compact Disks (CD-ROMs/CD-Rs/CD-RW)

- i) **Compact Disk:** Computer compact disks look like the compact disks used for music and they work in the same way. The earliest compact disks (CD) were read only, hence the name CD-ROM (Compact Disk Read Only Memory). However, recordable CDs known as CD-R (Compact Disk Recordable) and read/write CDs known as CD-RW (Compact Disk Read/Write) are now available. Therefore, with CD-R disk, you can put a blank disk in the CD-R drive and use it to save your own data or programmes. Also, it is possible to read from and write to special optical disks many times using CD-RW.

The capacity is larger than that of floppy disk, and smaller than the Hard disk. The capacity ranges from 250MB, 550MB 659MB and above. CD drive is often referred to as **drive D**.

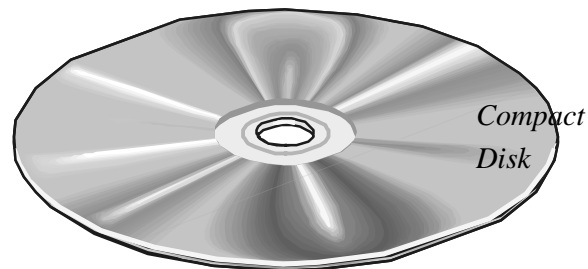

Zip Disk: It is larger in capacity than floppy disk, but smaller than compact disk. It is capable and generally big enough to store graphics, transfer of files between work and home and saving of Internet downloads.

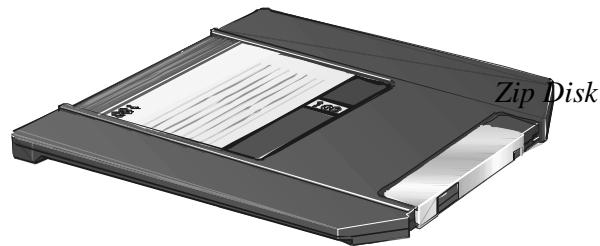

Flash Drive: It is typically small, lightweight, removable and rewritable. A flash drive consists of small printed circuit board encased in a robust plastic or metal casing, making the drive sturdy enough to be carried in a pocket, as a keyfob, or on a lanyard. They are more compact, generally faster, hold more data, and are considered more reliable (due to their lack of moving parts) than floppy disks. These types of drives use the USB mass storage standard supported by modern operating system such as Linux, Mac OS and Windows.

Memory capacity typically ranges from 128MB to 64GB



*Flash
Disks*

SELF ASSESSMENT EXERCISE 4

What are the labels conventionally attached to the following storage media and with what alphabet?

- i) Hard Disk ii) Diskette iii) Compact Disk

3.1.5 System Unit

The system unit is made up of all that make what you actually call a computer, and the devices are as follow. However, these are addition to what you have learnt already about CPU.

Motherboard: This is the underlining part of the computer for **desktops CPU** on which every other component of the system unit, except the power pack and disk drives are mounted. It is made up of silicon board just as those of the radio or television.

Power Park: This is a component of the computer that distributes the amount of current required by the different components of the computer to such components.

Slots: These are the outstanding parts of the motherboard. They are rectangular in shape with grooves in the middle in which cards are slotted.

Cards: These are devices that make available the interface for the connection of external devices to the computer Examples of such cards are the printer, TV-card audio or video, VGA modem etc.

Ports: These are provision at the back of the cards on which all external devices are connected; there are two main types of ports parallel and serial ports of which the parallel port transmits data bit by bit out, one bit in, in a communication that is bi-directional, and the serial port transmits data-eight bits at a time and simultaneously in a bi-directional communication.

3.1.6 Parts of a Computer

The computer has different parts, but the main essential parts of the computer are:

1. The Monitor (Visual Display Unit)
2. The central Processing Unit (CPU)
3. The Keyboard
4. The mouse

3.1.7 Supporting (Peripheral) Devices

Other parts of the computer that are not members of the main part are referred to as peripheral devices. It is possible to do without them. They perform input, output or storage function outside but under the control of the computer. Examples: are Printer, Speakers, Scanner, Microphone, UPS etc.

3.2 Software

Speaking in terms of computers, software is a set of instructions – the computer programs that are used to command the computer. People develop softwares to describe their processing needs to the computer, the software in turn, operate the computer hardware to perform the task. They are the invincible or intangible portions of the computer that instruct the computer hardware on how to carry out tasks. Computer software can be divided into two broad categories – System and Application.

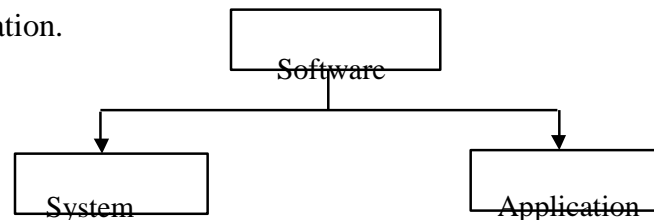

3.2.1 System Software

The system software is also referred to as operating system (O.S.). The computer as a complex machine has important software that allows you to communicate with it, i.e. the system software. The operating system provides the routines needed to allow application softwares to interact with the hardware. In other words, they are programs that interpret user's programme commands that are contained in application programmes and activate the proper hardware circuit and device to perform the processing. In short, the O.S. is a collection of programme

modules that act as interface between the computer hardware and the user.

3.2.2 Application Software

These are programmes created to perform a specific task; they provide the user's end desire. In other words, they are programmes created specifically to meet the user's needs. The ones developed by the manufacturer are called **Generalized Application Software**, while those developed by the user are called **User Program** or **User-define Software**.

Application programs are categorized into different groups according to their functions and purpose. Some of the Generalized Applications Packages are as follows:

Word processing Softwares: These are software packages that are used for typing and printing of all types of documents. They allow entering of text and quality typesetting. Examples of word processing software are: Microsoft word, Word perfect, Grammatik, Word Star, Display Writer etc.

Spreadsheet Management Software: These are softwares that are used for calculation, and they can also be used to do some graphics, word processing and database management. They are in form of matrix i.e. rows and columns, which control the table of cells. Examples of spreadsheet management softwares are Microsoft Excel, Lotus 1-2-3, Super Calc, Quattro pro, Super Project, Math Cad, Oracle etc.

Graphics: These are software that are used for drawing or producing beautiful pictures, objects, Sketches etc for use in desktop publishing and otherwise. Examples of such softwares are Freelance Graphics, ABC Flow Chart, More Font, PM Plus, Corel Draw etc.

3.3 Computer Virus

This is a programme that affects other programmes in the computer without your awareness. In other words, the computer virus is a set of coded instruction that comes into the computer through a foreign disc or network. The first thing it does is to attach itself to critical files, then replicate and spread through the whole system. Some viruses normally cause unusual screen display or behaviour.

Types of Virus

Some of the notable viruses are: Black Friday, Black Wizard, Acid Virus, Yankee (OPEY A – New name), Stone (MARKER A – New name), Amoeba (W Bleba.worm – New name), Aids, Demon, Ghost, Athens, Sadam, Striker, Red State, Blood e.t.c

Causes of Virus

- i. By allowing others to use diskettes of their own on your system without scanning with any Anti-Virus.
- ii. Software piracy i.e. illegal duplication of software might transfer a virus from one disk to another.
- iii. When a computer is connected to the network, it stands the chance of contacting virus.

Preventive Measure against Virus: All viruses are destructive; therefore, prevention is better than cure.

- i) Immunity of system against virus with Anti-Virus programme is highly recommended
- ii) Any borrowed diskette should always be scanned for virus with Anti-Virus programme before usage.
- iii) Dust should be avoided as much as possible in the computer room to avoid blocking of circuit in the system unit.

Anti-Virus: Anti- Virus is a software programme that is used to correct or remove the infection of virus on the computer. Some of the anti-virus programmes are: Ultra secure, PC Guard, Norton Anti-Virus, Virea, Dr Solomon, Computer lock, McAfee, Watchdog Turbo Lock, and PC Assure etc.

3.4 Booting

Booting is a computer language, meaning - to switch on the computer or to start it. It is also called Bootstrap. When you switch on your computer, it will carry out diagnostic routine by looking through its memory (RAM) chips to make sure that they are all working properly. In that process, the computer is booting.

Types of Booting: Booting can be done in two ways – **Cold booting** and **Warm booting**.

Cold Booting: It is the starting of a computer by pressing the power (On/Off) button. You instruct somebody to “cold boot the computer”



and do not say: “put on the computer” or “power the computer” or “start the computer”

Warm Booting: It is the process of restarting your computer without putting it off, using the Reset button. Warm booting can also be done by pressing Ctrl + Alt + Del keys on the keyboard. However, warm booting must not be done when the computer is on (without a problem); unless the computer happens to hang during operation.

SELF ASSESSMENT EXERCISE 5

(Practice)

How to cold boot (start) the computer

Press the power (On/Off) button. If power is not written, look for Zero (O) and One (1) symbol such as these:  or  .

3.5 Shut Down/Turn Off Command

Computer is not like other electronics e.g. Television, Radio etc that you can switch off directly whenever you are through with it. It has a procedure of shutting down first before you press the power button if the system is not the automatic type.

SELF ASSESSMENT EXERCISE 6

(Practice)

How to shut down or turn off the computer

- Before you attempt to shut down ensure that **no programme is currently running or minimized** on the **task bar**.
- Activate the **start button**.
- Click the **Shut Down** command or **Turn Off** depending on the version of windows you are using. For instance the shut down dialog boxes of windows 2000 windows XP are displayed below:



- Select **shut down** option. (Windows 2000) Click on **Turn Off** (Windows XP).
- Click **OK** or press **enter key** (Windows 2000, 98 etc).

4.0 CONCLUSION

What makes up the computer system is the Hardware and software. Hardware are physical or tangible parts of the computer and the software are the intangible parts or programmes that are used to instruct the hardware.

5.0 SUMMARY

The system software (operating System) serves as interface between the application software that meets the user's needs and the hardware. Example of an Operating System is windows and example of application software is Word Processing or Spreadsheet Management.

6.0 TUTOR-MARKED ASSIGNMENT

1. Outline the procedure of how to shut down or turn off the computer.
2. Actually the computer virus is different from animal virus, but they have certain similarities. Discuss.
3. Write short notes on the following computer terms:
 - i. Peripheral Devices
 - ii. Ports
 - iii. Slots

7.0 REFERENCES/FURTHER READINGS

[.google.com](http://google.com), Parts of a computer.

Ian Ithurralde, Anne Ramkaram, *This is IT 2*, Second Edition.

MODULE 2

- Unit 1 IT and MIS in Education: Windows Operating System
- Unit 2 Windows Operating System Continued
- Unit 3 Windows Screen Layout
IT and MIS in Education Computer Electronic Word
Processing Using Ms-Word: Ms-Word Screen Layout and
- Unit 4 Features
Microsoft Word (Ms-Word) Continued: Text Formatting
- Unit 5 and Editing
Microsoft Word Continued: More Formatting, Editing and
Printing

**UNIT 1 IT AND MIS IN EDUCATION:
WINDOWS OPERATING SYSTEM**

CONTENTS

- 1.0 Introduction
- 2.0 Objectives
- 3.0 Main Content
 - 3.1 What is Windows Operating System (O.S)?
 - 3.2 Loading Windows Operating System
 - 3.3 Features and the Screen Environment
 - 3.4 Basic Techniques on How to Use the Mouse
 - 3.4.1 Clicking
 - 3.4.2 Double Clicking
 - 3.4.3 Dragging
 - 3.4.4 Pointing/Locating
 - 3.5 Start Button
 - 3.6 Menu
 - 3.6.1 Moving within Menu Items
 - 3.7 Menu Conventions
 - 3.7.1 Underline Character
 - 3.7.2 Ellipsis (...)
 - 3.7.3 Right-Facing Triangle (▶)
 - 3.8 Shortcut
 - 3.9 Opening of Icons
 - 3.10 Selecting (Highlighting) and Choosing Icons
 - 3.11 Dialog Box
 - 3.11.1 Moving Dialog Box
 - 3.11.2 Closing a Dialog Box
- 4.0 Conclusion
- 5.0 Summary
- 6.0 Tutor-Marked Assignment

7.0

References/Further
Readings

1.0 INTRODUCTION

Already, part of Windows Operating System had been explained in the last Unit of Module 1, i.e. how to boot the computer and turn it off. In this unit, you will know what is meant by Windows and what you can do with them. Therefore from now on, try to be by your system for the practical demonstrations and exercises.

2.0 OBJECTIVES

At the end of this unit, you should be able to:

- define Windows Operating System
- recognize windows environment and its features
- understand the basic techniques on how to use the mouse
- distinguish between menu and menu conventions
- explain what is shortcut and how to create it
- understand how to open an icon and differentiate between selecting and choosing an icon
- identify a dialog box.

3.0 MAIN CONTENT

3.1 What is Windows Operating System (O.S.)?

Windows is one of the operating systems that makes use of Graphical User Interface (GUI) under the environment of WIMP (Windows, Icons, Menus and Pointers) as shown below:

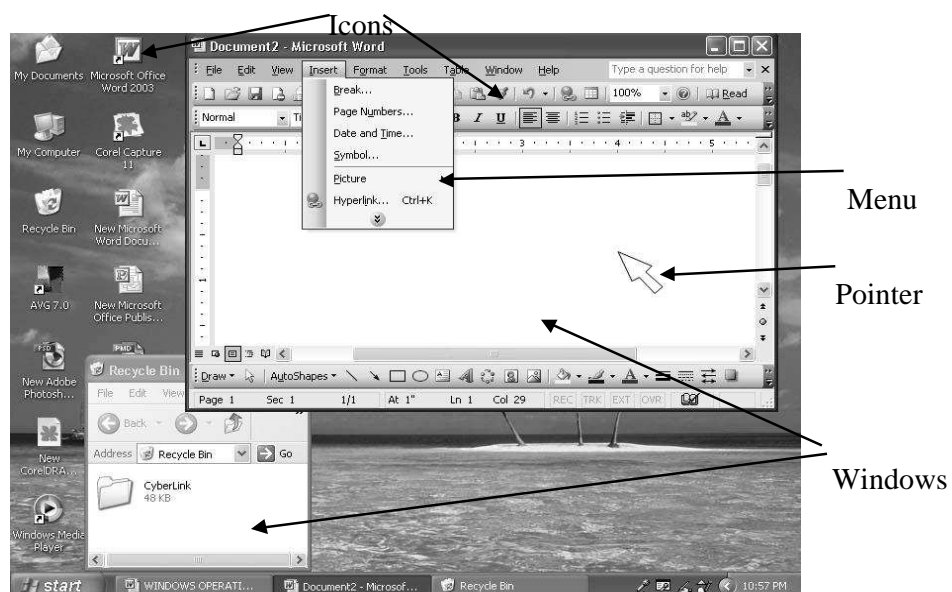

A graphical interface

As an Operating System, it serves as intermediary between the hardware and the user's application software. With Windows O.S., it is possible to switch between programmes without closing down one and open the next. Many windows can be opened at one time, although only one can be active at any given time.

We have different versions of Windows OS such as 3.1, 95, 98, Me, 2000, XP etc. However, apart from the earliest versions (3.1 and 95), others have slight differences; therefore once acquainted with one e.g. 98 others will not create fear or threat.

It is easy to learn Applications associated with windows because of its consistency of graphical interface from one application to another. Once you are familiar with one application like **MS-Word**, you have already learnt the essentials for using any other application.

With Windows OS, you can execute the same command by using several methods, but here we shall be practising with one or two methods even though the particular command has many methods of carrying it out. Therefore, you are free to use other methods known to you in such situations.

3.2 Loading Windows Operating System

In the last unit of Module 1, we practised how to start the computer. In another way, it is the same language when you say: how to load Windows OS. However, in order to refresh our memory, we shall still practice it

Practice 1

How to start Windows

- To start windows OS, **cold boot** the computer by depressing the **power button**. Then wait until when the pointer is single like this:  It indicates that it has finished booting.

3.3 Features and the Screen Environment

After the computer has finished booting successfully, it will stop at the environment called **desktop**. Depending on how your computer is set up, various **items (icons)** will appear on your desktop. A bar called the **taskbar** will appear at any edge of the four edges of the screen, normally at the bottom; and a **pointer** as shown below:

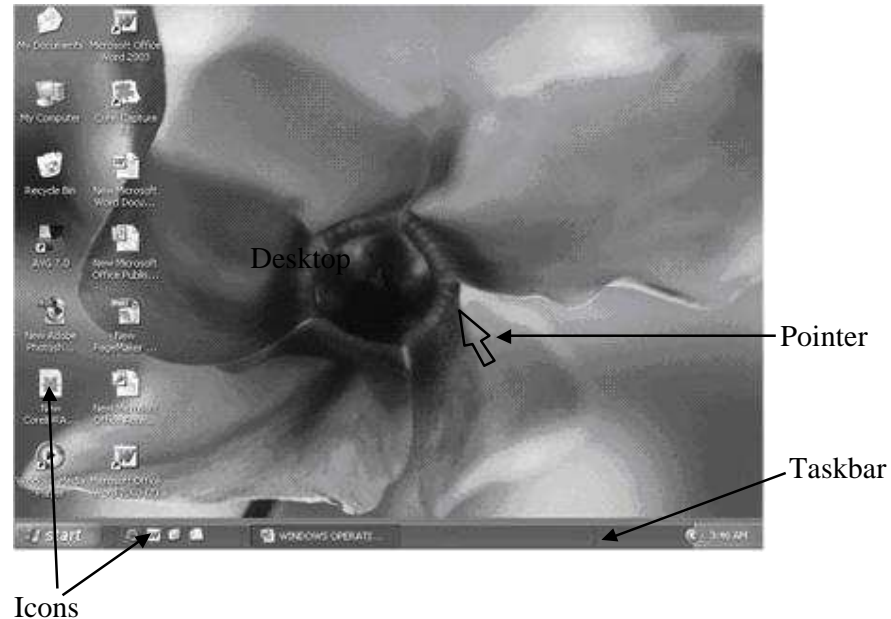

Desktop environment

Desktop: is the environment where you can start anything you want to do after the computer has finished booting. The items that you see scattered on the left side of your desktop are called Icons.

Icons: An Icon is a command in picture form. Each icon represents an object such as a folder or an application program. Examples of some icons you can see at the desktop are: My Computer , My Documents , Internet Explorer , Recycle Bin  etc. These could also be created on the taskbar as shortcuts too.

Icons are merely **Shortcuts** to Application Programmes or Files that you have created using any application. (*See notes on shortcuts in page 52*).

Pointer: Is used in conjunction with an input device such as a mouse, to point to various parts of the display.

Taskbar: The taskbar is normally found at the bottom of your screen when you start windows for the first time. By default, it is always visible when running windows Applications. At anytime you start a programme or open a window, a button representing that program or window will appear on the taskbar and when you close the window, its button will disappear from the task bar.

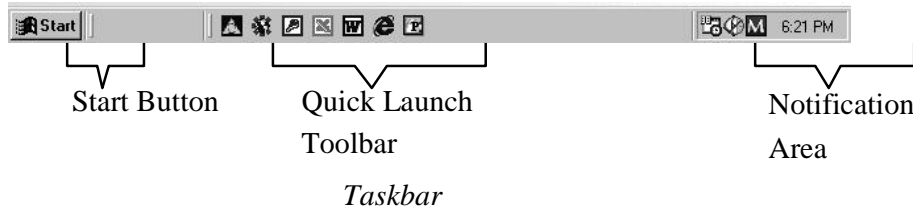

***Note:** It is possible to put toolbars as many as you want on the taskbar, but it is not ideal because it may make the buttons of some active windows to hide.*

3.4 Basic Techniques on How to Use the Mouse

The motive of bringing this topic here is to eliminate the difficulties you might face with the language associated with the mouse that your instructor will be using during the practical exercises in the course.

3.4.1 Clicking

This is pressing and releasing of a mouse button either left or right button. Whenever your instructor asks you to click the mouse, what he expects you to use to click is the left mouse button. When there is need for you to use the right button he will say **right click**. Therefore wherever you see click or click on anything, you are expected to use the left button. There is nothing like **left click** in computer parlance.

3.4.2 Double Clicking

Is a way of pressing and releasing the mouse button particularly the left mouse button twice in rapid succession (very fast).

3.4.3 Dragging

Is a way of pressing a mouse button and holding it down while moving (dragging) the object to where you want it.

3.4.4 Pointing/Locating

This entails moving the pointer until its tip rests on a specific object you want to use before you click or double click. Examples of good and bad pointing are shown below:



Bad



Bad



Good



Note: In situations where the mouse pointer will change from the **spear head shape** to other shapes, it will change by itself when it gets to that particular position or spot.

3.5 Start Button

The start button on the task bar, is used to start a program, open documents, change system settings, get help items etc. When you activate the start button, a **menu** called the **Start Menu** that contains everything you need to begin with windows will come out as shown below:

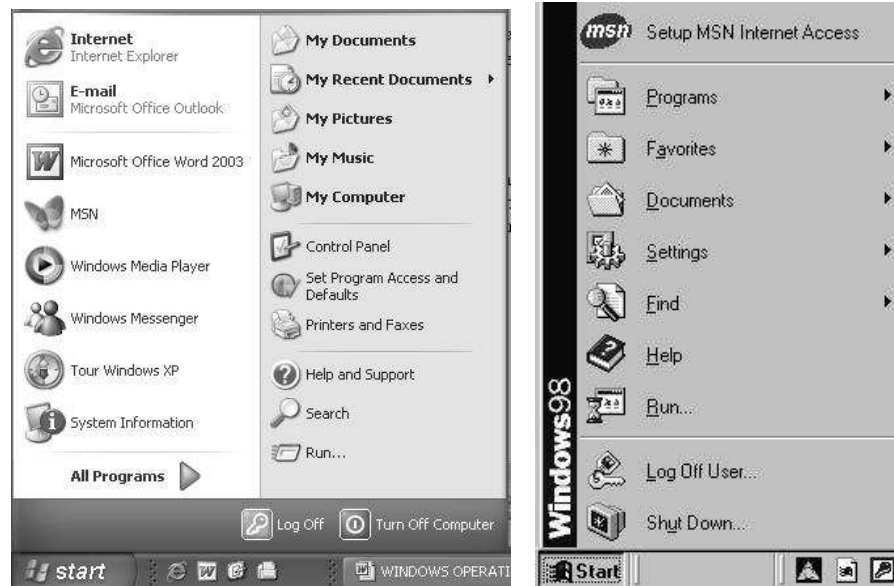

Start Menu of Windows XP

Start Menu of Windows 98

3.6 Menu

Menus offer the user a choice of functions associated with an application or operating system. Therefore the start menu reveals most of the possible commands you can use to start working with windows.

Practice 2**How to bring out the Start Menu**

- Click on the **Start Button** itself

*Press **Escape** key or click outside the menu since you will not proceed further.*

Optional Method

- Press **Ctrl (Control) + Esc (Escape)** keys on the keyboard

***Hint:** Use one finger to hold Ctrl key down and use another finger of the same hand or the other hand to tap Esc Key.*

3.6.1 Moving Within Menu Items

Movement within the start menu and other menus is done either by using the **mouse pointer** or by pressing the **navigator keys**



on the keyboard. Movement with the mouse is done either **vertically** or **horizontally** and not **diagonally**.

Practice 3**How to move within Menu Using the Mouse**

- Activate the **Start Button** with the **mouse**
- Move the **mouse pointer** up and down, left and right to select any **command**.

For example,

- Move the **Pointer** to **Programmes (All Programmes** in Windows XP)
- Again move the **Pointer** to **Accessories**, and then click outside the menus to remove them.

Optional Method – Using the Keyboard

- Activate the **Start Button** with the keyboard, then use the **navigator Keys** to move up / down or left / right as the case may be.

For example, press the **up arrow key** to locate **Programs** (**All Programs** in Windows XP), press the **right arrow key** to bring out the second menu, then press the **up** or **down arrow key** to locate **Accessories** and press the **right arrow key** to bring out the third menu. Press Esc key until all the menus are removed.

3.7 Menu Conventions

Menu conventions are common rules associated with menus in Windows and other windows application programs that make a user to have easy short cut to certain commands.

3.7.1 Underline Character

The underlined character under a menu command gives you fast access to a command using the keyboard.

Practice 4

How to use the Underline Character

- Activate the start Button with the keyboard by pressing **Ctrl + Esc Keys**
- Press **R** key on the keyboard since it is the underline character in **Run** to activate the Run command
- Press **Esc key** to remove the Run dialog box

Note that the underline characters in some other menus need to be activated by pressing the underline character with the Alt key.

3.7.2 Ellipsis (...)

An ellipsis command leads to a diagonal box. Wherever you see a command with three (3) dots (...) in front of it, expect a dialog box. For example the Run command in the start menu.

3.7.3 Right-Facing Triangle (▶)

Commands with this symbol: ▶ in front of them leads to second menu and secondary menu can lead to another as the case may be.

Practice 5

How to use the Right-Facing Triangle

- Activate the **Start Button** with any method
- Locate **Programs (All Programs)** in windows XP)
- Locate **Accessories**
- Locate **System Tools**
- *You will notice four (4) cascading menus on the screen*
- Press **Escape key** or **click outside** the menu since you will not proceed further.

3.8 Shortcut

Icons that you see at the desktop and the taskbar are shortcuts to Application Programmes or other Folders. Therefore, shortcuts are icons created for easy access to a file or folder that you use frequently. A shortcut does not change the location of a file. It is simply a pointer that allows you open the file quickly. If you delete the shortcut, the original file still remains intact.

Practice 6

How to create Shortcut on the Desktop

We shall practise with **Microsoft Word (MS-Word) Icon**. Check whether if it is already on the desktop. If there is one or two already, yours will now be number 2 or 3 as the case may be

- Activate the **Start Button** with any method of your choice
- Locate **Programs (For Windows XP 2003 Version, after you have located Programs, locate Microsoft Office)**
- Right click on the **application program** i.e. **Ms-Word** in this case
- Locate **Send To**
- Click on **Desktop (create shortcut)**



Microsoft Word shortcut (Icon) with **big W logo** will appear on the desktop

Practice 7

How to create Shortcut on the Taskbar

You will still practise with the Microsoft Word (MS-Word) Icon you have created on the Desktop.

- Right click on the **Icon** (MS-Word) at the **Desktop**
- Then hold and drag it to the area of **Quick Launch** on the Taskbar and release your hand from the mouse. And the following menu will pop up.

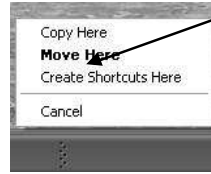

Click on **Create Shortcut Here** option

If you use the left mouse to drag, you will not see this menu but the shortcut will be created.

*Note that the shortcut will not stay if the **Quick Launch** is not on the Taskbar. The **Quick Launch** part of the Taskbar is the section where your shortcut can stay.*

Practice 8

How to check whether the Quick Launch is on the Taskbar

- > Right click on any **empty space** of the **Taskbar** to give you a menu such as the one below:

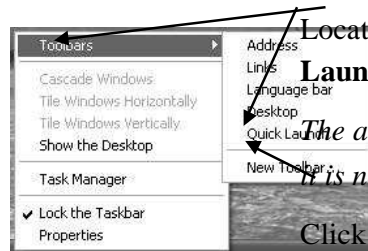

Locate **Toolbars**, and subsequently move to **Quick Launch**

*The absence of the **check mark (good mark)** denotes that it is not on the Taskbar*

Click on **Quick Launch** command to check it (make it available).

3.9 Opening of Icons

There are many ways of opening icons on the desktop, but there is only one way to open an icon on the taskbar and other bars.

Practice 9

How to open an Icon on the Desktop

We shall use the **MS-Word**  icon we have just created to practise how to open an icon on the Desktop. Although we are yet to practice how to close windows, you can use the close buttons (□, □) at the top extreme right corner to close the windows

- Double click on the **Icon**  and not on the name of the Icon underneath.

Optional Method

Right click on the **Icon**, and then click **Open** command from the pop-up menu.

Practice 10

How to open an Icon on the Taskbar

If an Icon is on the **Taskbar** or any other bar, **click on it**  **once** in order to open it. For example click on the **MS-Word Icon** you have created on the Taskbar.

3.10 Selecting (Highlighting) and Choosing Icons

In windows, the terms **Select** and **Choose** have different meanings. Selecting an item usually means marking it with the selection cursor, which can appear as a highlight, a dotted rectangle with Radio Button or both. Selection alone does not start an action. You choose an item to carry out an action.

Practice 11

- Click on **My Document Icon**  to select it.

You will notice that it now has a different colour or highlight depending on how your computer is set up.

- Press **Enter** key to open (choose)

Note: This is another way of opening an Icon

3.11 Dialog Box

A dialog box is a small window where you will be required to give further details on how your command is to be executed. Windows O.S. displays a dialog box when it needs additional information to complete a task. Most dialog boxes contain options you can select from. After you specify option, you can choose a command button to carry it out.

Some dialog boxes may display information, warnings, or message indicating why a requested task cannot be accomplished.

For instance, when you click on the **Run** and **Shut Down** or **Turn off computer** commands in the Start menu, the dialog boxes below will be seen.

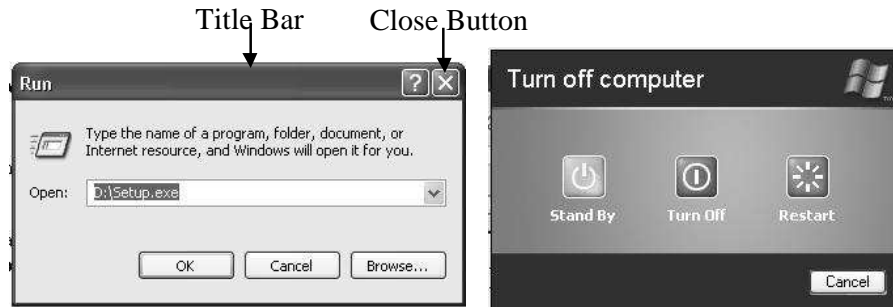

Run Dialog

Turn off computer Dialog box

box

3.11.1 Moving Dialog Box

If a dialog box has a title bar, you can move the dialog box to another location on your desktop. For instance the Run dialog box above has a Title bar, but the Turn off computer has none. Moving a dialog is just like moving window.

Practice 12

How to move a Dialog Box

- Activate the **Start Button** and click on **Run** Command

Run dialog box such as the one below will come up

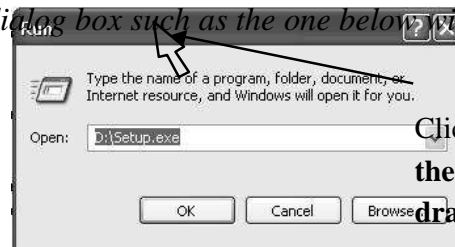

Click on the **title bar**, then **hold the mouse button down and drag it** to the center of the screen.

3.11.2 Closing a Dialog Box

When you choose a command button, the dialog box closes and the command is carried out. You also use the close button, cancel and Esc key to close the dialog box.

Closing the dialog box to complete the command

- Select the **option** and click **OK** or **Yes** button

Closing dialog box without completing the command

- Choose the **cancel button**, or press **ESC**.

4.0 CONCLUSION

Under line character in a command pave way to a shortcut to the command; ellipsis command makes you to realize that a dialog box will come out whenever the command is activated. And when the mouse pointer points to a right-facing triangle command, it brings out a second menu which can also lead to third menu as the case may be.

5.0 SUMMARY

Selecting and choosing a command in computer have different meanings. Selecting a command means to mark it out different from other commands without carrying out the action. On the other hand, choosing means to carry out the action after selection.

6.0 TUTOR-MARKED ASSIGNMENT

1. Explain the following terms associated with the mouse:
 - i. Double Clicking
 - ii. Dragging
 - iii. Pointing/Locating
2. State any two methods of how to open an icon on the desktop.

7.0 REFERENCES/FURTHER READINGS

Ian Ithurrealde, Anne Ramkaram, *This is IT 2*, Second Edition.

French, C.S (2000). *Computer Science*, Asfifor Colour Press: Gosport Hants, 5th Edition.

UNIT 2 WINDOWS OPERATING SYSTEM

CONTINUED WINDOWS SCREEN LAYOUT

CONTENTS

- 1.0 Introduction
- 2.0 Objectives
- 3.0 Main Content
 - 3.1 What is a Window?
 - 3.2 Parts of a Window
 - 3.3 Resizing Windows
 - 3.4 Moving Windows
 - 3.5 Scrolling
 - 3.6 What You Can Do With Windows
 - 3.6.1 Changing the Appearance of Windows
 - 3.6.2 Screen Saver
 - 3.6.3 Computer Time/Date
- 4.0 Conclusion
- 5.0 Summary
- 6.0 Tutor-Marked Assignment
- 7.0 References/Further Readings

1.0 INTRODUCTION

In this unit you will learn what a window is, the various parts of a window and what you can do with window.

2.0 OBJECTIVES

After completing this unit, you should be able to:

- define windows, label its different parts, and practice how to minimize, restore, maximize, close and resize a window
- learn how to use the scroll arrow and scroll box to scroll both horizontal and vertical scrollbars of a window
- know how to change the background or wallpaper and screen saver of a window
- set the date and time of the computer.

3.0 MAIN CONTENT

3.1 What is a Window?

A window is a box or frame on the screen. For example, the frame below is My Documents' Window. It contains more commands than the Dialog box and it is also bigger in size.

When you work with applications, you often have a number of windows opened. Therefore, we shall use this part of windows as a preamble to explaining some of the common features of windows; however some have been dealt with already under dialog box.

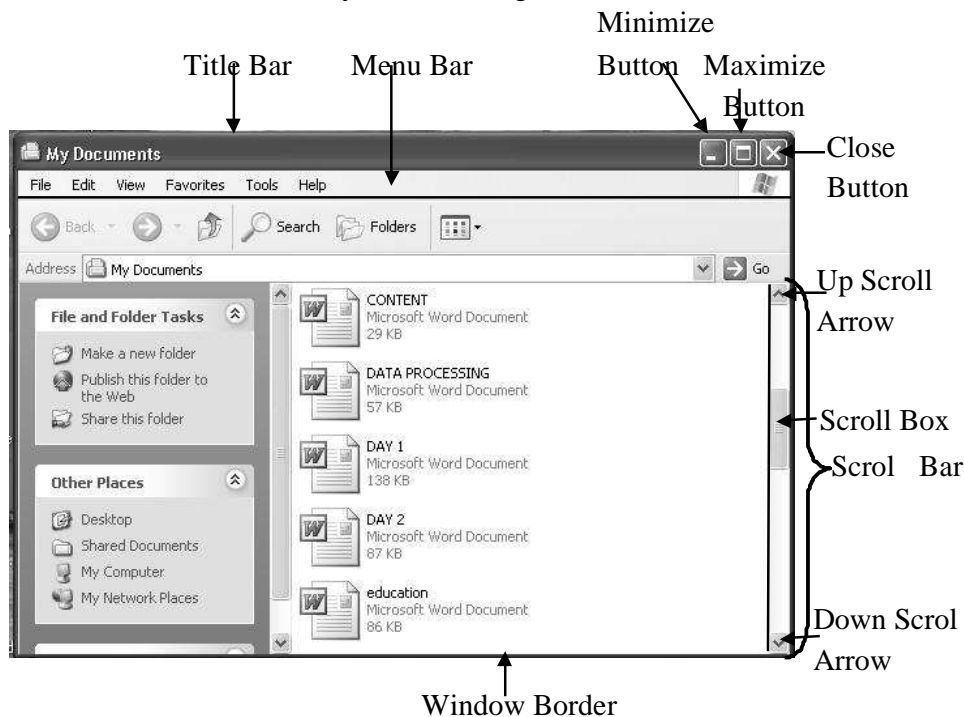

My Documents' Window showing Parts of a Window

3.2 Parts of a Window

Most windows have certain elements in common such as title bar and a menu bar. However, not all windows have every feature. The following are some of the common features.

Title Bar: Shows the name of the application or document. If more than one window is opened, the title bar for the **active** window (the one in which you are working) is usually colour or intensity than other title bars.

Menu Bar: Lists the available menus from which you can choose commands.

Scroll Bars: Enable you to move through document or a list when the entire document or list does not fit in the window or the allocated space.

Maximize Button (□): Clicking this button with the mouse enlarges the active window so that it fills the entire desktop. The button will be visible if the window is not yet in its fullest size.

Restored Button (☐): Replaces the maximize button after you enlarged a window to its fullest size.

Minimize Button (-): Reduces the window to an icon at the taskbar. You will notice that the window will disappear from the screen, but it is not closed. You can still open it from the taskbar by clicking on the **Icon**.

Windows Borders: Are the four outside edges of a window. You can change the window size by lengthening or shortening the boarder on each side of the window.

Practice 1

How to minimize a Window

- Open **My Documents Icon**  on the Desktop to bring out **My Documents** window such as the one below:

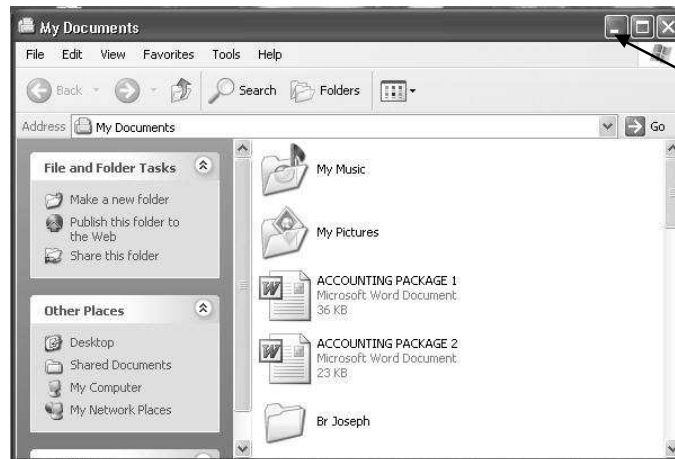

Click on the **Minimize Button**

You will notice that the window has disappeared from the screen and now an Icon or Button on the Taskbar as shown below:

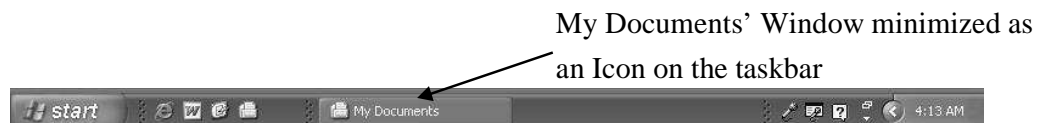

My Documents' Window minimized as an Icon on the taskbar



The minimized button might be in short form such as: **My Doc...** or only the **Icon** 

- Click on the **Minimized Icon** on the taskbar to make it reappear.

Practice 2

How to maximize and restore a Window

Try to identify Maximize and Restore buttons in My Documents' Window above.

- Click on the **Maximize Button**  or **Restore Button**  of My Documents' Window above depending on how your window is at present.

*You will notice that the **Maximize Button** enlarges the window to occupy the whole desktop while **Restore Button** returns the window to its previous size. Also, Maximize button replaces Restore Button after clicking on Restore Button and vice-versa.*

Practice 3

How to close a Window

- Click on the **Close Button**  to close the window

3.3 Resizing Windows

In addition to Maximize and Restore buttons which you can use to resize window to take different sizes, **window border** could also be used to resize windows to your taste.

Practice 4

How to use the Window Border to resize a Window

Open **My Documents Icon** on the Desktop to bring out a window such as the one below:

- Click on **Restore Button** if the window is maximized.

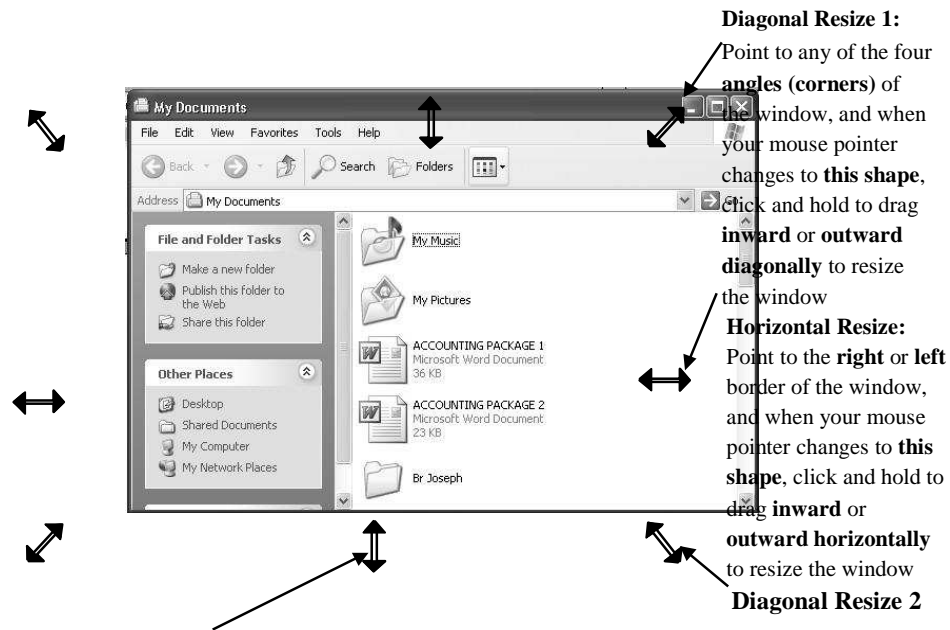

Vertical Resize: Point to the **top or bottom** border of the window, and when your mouse pointer changes to **this shape**, click and hold to drag **inward or outward vertically** to resize the window

***Hint:** if you want to make the window smaller by dragging inward, either vertically, horizontally or diagonally, drag as if you are going to meet the opposite side. And note that it is only the diagonal resize that will not change the aspect ratio of the window.*

3.4 Moving Windows

Moving a window to a different place on the screen can make it easier to see more than one window at a time or see something the window is covering up.

Practice 5

How to move Windows

- Open **My Documents** Icon on the Desktop
- Click on **Restore Button** if the window is maximized
- Click on the **Title bar** of the window, then hold and drag to a new location, just the same way you move a dialog box.

3.5 Scrolling

Some windows and dialog boxes have scroll bars you can use to view information that does not fit inside the window or dialog box. In situations where you can view all the contents of a window or dialog

box without scrolling, scroll bars may be absent or dimmed to indicate that they cannot be used. However, if a window is not large enough to display all the information, a scroll bar appears at the right-hand side and/or bottom of the window. That is **vertical** and **horizontal** scroll bars.

Please see My Documents window under parts of windows above to identify scroll bar and its parts. Note that it is only the vertical scroll bar that is present here. Is there horizontal scroll bar in your window? You can also use it to practise too, if yes. The scroll bar(s) may be absent if your computer is new or there are no many files in my document folder.

Practice 6

How to scroll either Horizontal or Vertical Scrollbars

- Open **My Documents** Icon at the Desktop
- Click on **Restore Button** if the window is maximized.

Using the scroll box:

- Click on the **Scroll box**, **hold and drag** through all the information in a list or document. This is the fastest way of scrolling.

Using the scroll arrows:

To Scroll	Do this
One Line up or down	Click the up or down scroll arrow
Continuously	Point to one of the scroll arrows , click and hold down the mouse button until the information comes into view.

3.6 What You Can Do With Windows

You can use windows to perform different tasks. Some of the tasks you can use windows to do are as follow:

3.6.1 Changing the Appearance of Windows

You can personalize windows with patterns, pictures and colours by using control panel. You can display pictures or patterns as well as wallpaper for windows or use your own scanned pictures.

Practice 7**How to change the Background or Wallpaper of the Computer**

- Right click on the **empty space of the desktop** to bring out a **Menu** like the one below:

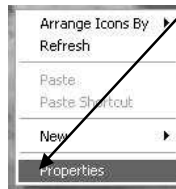

Click **properties** option to bring out the **Display Properties dialog** box such as the one below

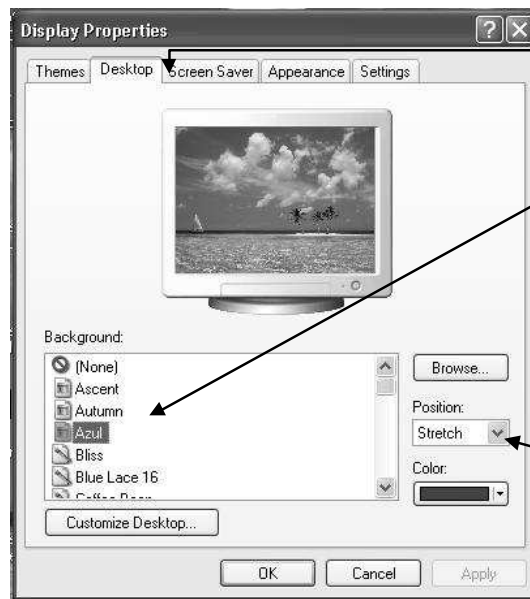

Click on **Desktop tab** or **background tab** depending on the window version you are using.

Select the **background** type of your choice. In this case, **Azul** is the selected option.

*You can also make changes on the **Position** of the background if you do not like the default type. In this case the position is on **Stretch**.*

Click on the down facing arrow to change it to **Tile** or **Center** and see the preview

Click **Apply** and **OK** to effect your changes.

3.6.2 Screen Saver

Screen savers are the different animations or displays that occupy the screen while the computer is idle after the stipulated time set. Screen savers can save wear and tear on your screen and protect your work when you are away. In your computer there are several of them that come with windows.

Practice 8**How to change the Screen Saver**

- Right click on the **empty space of the desktop** to bring out the **Menu** such as the one under Background or Wallpaper above.
- Click **properties** option to bring out the **Display Properties dialog** box such as the one below:

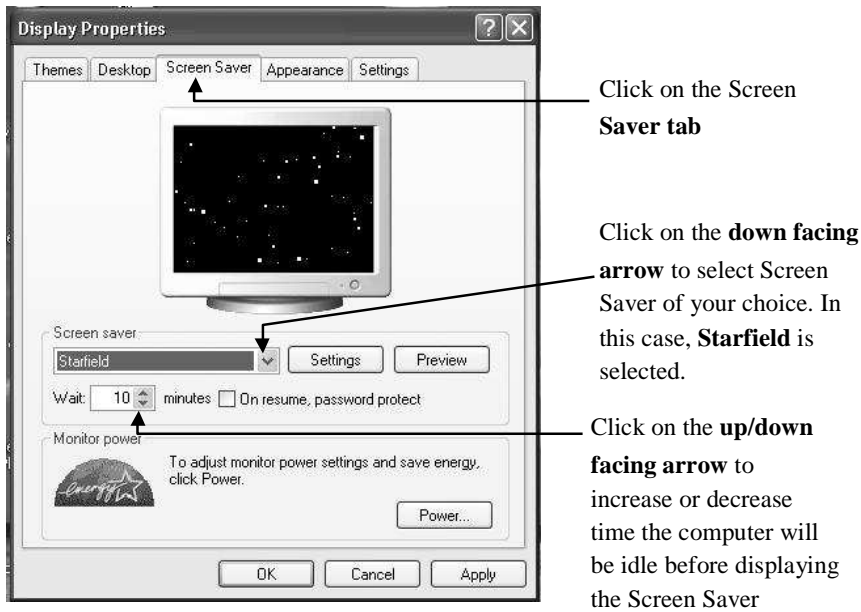

- Click **Apply** then **OK** to effect your changes.

Allow the computer to be idle for the time you set to see the display

- Press **any key** on the keyboard preferably, the **space bar** or shake the **mouse** to stop the Screen Saver display.

3.6.3 Computer Time/Date

The time of the computer is located at the right extreme of the Taskbar as shown below. Any file you create is maintained with the current settings. Therefore, the first thing you do after the computer has finished booting is to point to the clock to know whether the current date and time are correct



Mouse Pointer pointing to Clock to bring out further information.

- Double click the **clock** on the **taskbar** to bring out **Date and**

Time Properties dialog box as shown below:

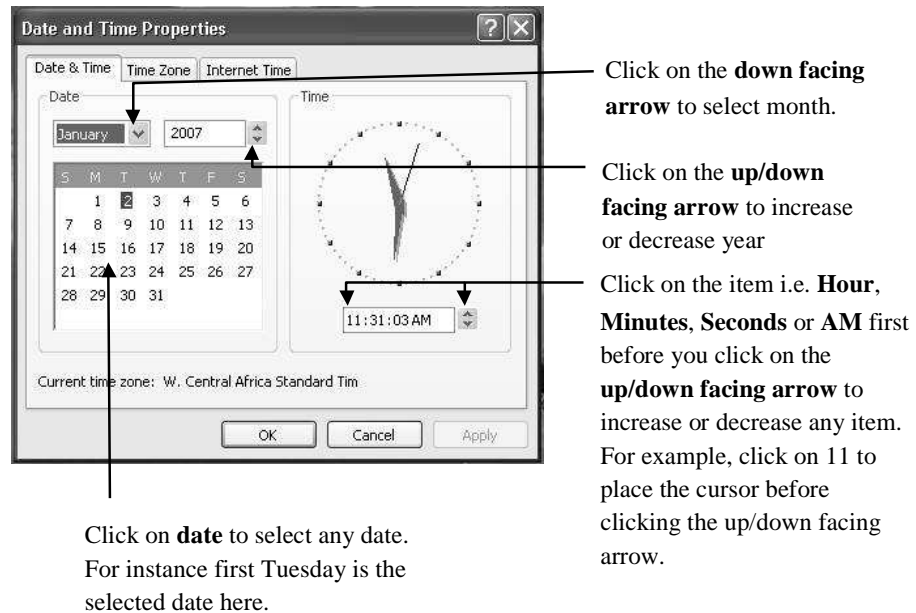

Practice 9

Make your changes as instructed below:

Year	1993
Month	September
Date	Last Friday
Hour	5
Minutes	42
Seconds	Omit or set at 01
AM/PM	If yours is on AM, change it to PM and vice-versa

- Click **Apply**, and then **OK** to effect your changes
- Point your mouse pointer to the **Clock** on the Taskbar and see what it is now.
- Double click on the **Clock** again and set everything that you have changed to the current settings.

4.0 CONCLUSION





A window could be resized by using the Restore and maximize buttons and any border of the window.



5.0 SUMMARY

The background and screen saver of the computer could be changed through the Display Properties dialog box.

6.0 TUTOR-MARKED ASSIGNMENT

1. Mention the name of the bar you can use to carry a dialog box or a window
2. What is the name of the bar a minimized window stay when it disappeared from the screen? What do you do to bring the minimized window back to the screen?
3. What is the name of part of the scroll bar you should use if you intend to scroll fast?
4. Give the names of the following buttons in a window:

	□		
i) 	ii) 	iii) 	iv) 
5. Give the names of the following mouse properties:

i) 	ii) 	iii) 
--	---	--

7.0 REFERENCES/FURTHER READINGS

Ian Ithurralde, Anne Ramkaram, *This is IT 2*, Second Edition.

French, C.S. (2000). *Computer Science*, Asfifor Colour Press: Gosport Hants: 5th Edition.

UNIT 3 IT AND MIS IN EDUCATION
COMPUTER ELECTRONIC WORD
PROCESSING USING MS-WORD:
MS-WORD SCREEN LAYOUT AND FEATURES

CONTENTS

- 1.0 Introduction
- 2.0 Objectives
- 3.0 Main Content
 - 3.1 What is Word Processing?
 - 3.2 What is Microsoft Word (MS-Word)?
 - 3.3 Word Screen Layout
 - 3.4 Hidden Toolbars
 - 3.5 Arrangement of Toolbars
 - 3.6 Active and Inactive Commands
 - 3.7 Page Setup
 - 3.8 Keyboard Keys
 - 3.9 Creation of a New Document
 - 3.10 Saving Documents (Files)
 - 3.11 Closing/Quitting Documents (Files)
 - 3.12 Opening of Files Saved in the Hard Disk
 - 3.13 Saving File/Folders in Other Storage Mediums e.g. Diskette, Zip Disk and Flash Disk
- 4.0 Conclusion
- 5.0 Summary
- 6.0 Tutor-Marked Assignment
- 7.0 References/Further Readings

1.0 INTRODUCTION

Applications (MS-word and MS-Excel) treated in this course did not cover the applications in computer wise, as you would expect. The topics selected are those that are considered to be of benefit to the actualization of the success of MIS in education especially in areas of acquiring, processing and dissemination of information in education. Note that the knowledge of MS-Word here has covered that of Word Pad which is normally used for web pages and e-mail messages. However, explanation on how to load and use it will be done briefly at the end of the module.

In this unit you will learn how to create documents, save them in the hard disk or other removable disks, and open them whenever the need arises.

2.0 OBJECTIVES

After you have studied this unit, you would be able to:

- explain what Microsoft word is and how to load it
- recognize the screen layout and the features
- identify toolbar and how to arrange them
- differentiate between active and inactive commands
- set up a page before creating a new document
- identify keyboard keys and use them
- create a new document, save and open it
- save and open file in Removable disks.

3.0 MAIN CONTENT

3.1 What is Word Processing?

Word processing is an act of preparing, organizing and production of document through the use of machine. Some of the applications for processing include: word perfect, word star, MultiMate advantage II, Display write, Textor, WinWord, Shakespeare etc. For our course MS-Word is used.

3.2 What is Microsoft Word (MS-Word)?

Microsoft word (MS-Word) for window is a word processing application programme used by modern secretaries, managers and corporate bodies to produce letter, chart graphics, memos, tables and borders etc.

Practice 1

How to load Ms –Word

You must start window before you load word since word is window based application programme. There are several ways to load word.

- Click on the **Start button**
- Locate **Program (All Programs in Windows XP)** and click on **MS-Word**

Optional Method



- Open the MS- Word Shortcut Icon on the **desktop** or on the **Taskbar** if it is created

After loading, two window will be displayed – the Microsoft Word NWINDOW and A DOCUMENT WINDOW.

3.3 Word Screen Layout

The document window that you will work with will display the following bars, icons, button on the screen.

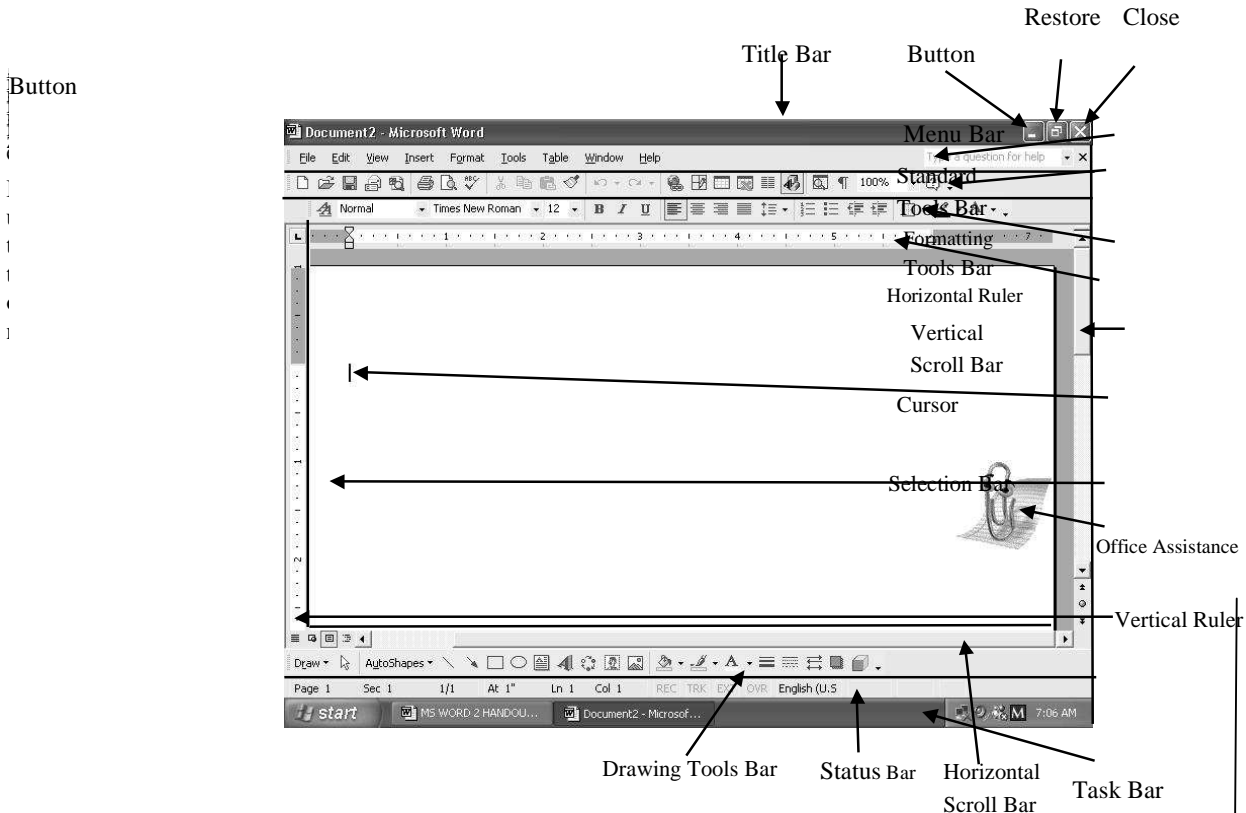

MS-Word Screen Layout

The different parts of the MS-Word welcome screen are explained below:

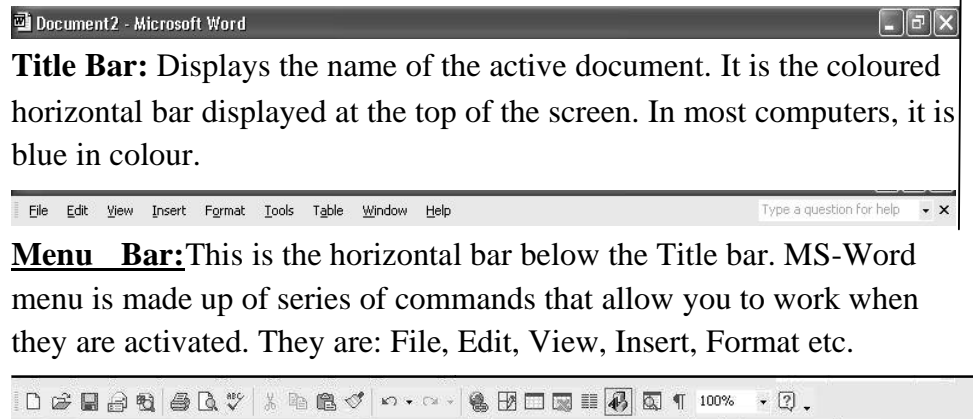

Standard Toolbar: Is the third horizontal bar at the top of the screen.

This bar consists of pictures (icons), which are shortcuts, to certain commands. In windows XP, from the first Icon, they represent: New, Open, Save, E-mail, Search, Print, Print Preview etc. Point to all the icons in to know their names



Formatting or Ribbon Bar: Helps you to quickly change the appearance of text. It is the fourth horizontal bar at the top of the screen. Depending on the arrangement of the bars, at times it overwraps the standard tools bar in some systems it is joined with the 3rd bar. If that is the case of yours, note it start with: Normal Times New Roman, 12, B, I, U, etc



Drawing Tools Bar: Helps you to draw some objects in word. It is located at the top button of your screen; it is the third segment of the tool bar.

Draw



Status Bar: It is located at the bottom of the screen just after the drawing tool bar. It contains information about the user's position in the active document, the use of the active tool etc, i.e. current page, doc number, cursor position in the document etc.



Task Bar: is at the bottom of the screen. It is all the time visible. At any time you start a programme or open a window, a button representing that programme or window appears on the Task Bar when you close a window its button disappears from the Task Bar Other item such as the clock might appear on the notification area of the Task Bar Also you can create shortcut to certain programmes on the Task Bar e.g Icon is a short cut to Microsoft Word.



Office Assistance: It offers on line help in Application Programmes.

That is, if the user appears to have performed an illegal operation or performing a task where ready made formats can be employed. While the office assistance can intrude into your work session on its own, it can also be triggered off by clicking on it. You can invoke it by clicking on the question mark icon  on the standard tool bar.

3.4 Hidden Toolbars

Toolbars you may want to work with but are absent from the screen are called Hidden Tools Bars. You can reveal and hide them if you wish as follows:

Practice 2

How to reveal Hidden Toolbars

- Activate the **View menu** and locate **Toolbars** as shown below:

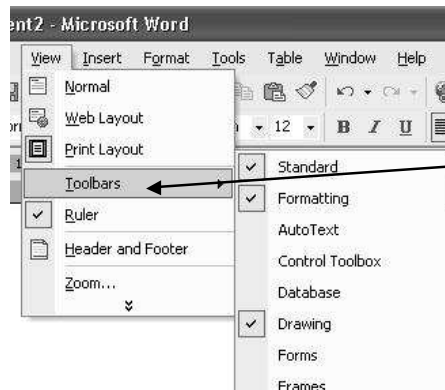

The toolbars with the **check mark (good mark)** are the ones present while others without the check mark are absent.

Click on any **toolbar** you want to reveal or hide. For example, uncheck **Standard, Formatting** and **Drawing** one after the other in order to hide them.

Follow the same procedure to reveal them by clicking on each of them one after the other again.

Optional Method

- **Right click** on any of the revealed bar, apart from the Title bar, preferably, the empty space of menu bar.
- Check (click) on any **toolbar** that has been unchecked

3.5 Arrangement of Toolbars

The arrangement of toolbars in any application program does not matter. At times the **Formatting** is seen before **Standard** or **Menu** bar. Also at times some Toolbars are placed vertically at the right or left hand side of the screen.

Practice 3

How to arrange Toolbars



Point to the **fainted vertical line mark** at the beginning of the bar, and you will notice that the mouse pointer will change to a cross shape like this: . Then click, hold and drag to any position where you want it.

Optional Method

- Click on **any place of the bar** (be careful not to click on any particular command or button), then **hold and drag** it to wherever you want it

Please use the first method if you are finding it difficult to locate the empty space between commands or buttons.

Rulers: (Horizontal and Vertical): These are used to measure the length and width of the user's work sheet.

Work Sheet: This is the electronic sheet with an insertion point given to the user to work with.

Insertion Point: Shows where text will be inserted when you type. (It is the I-shaped cursor that blinks on your screen).

Scroll Bar: This is used to control the focus and the display of the active document. It appears on the right edge and bottom edge of the document window. You can scroll by clicking or dragging the scroll bar.

Selection Bar: This bar is the region between the left edge of the document window and the left margin. It is an unmarked area along the left-hand side. This region (bar) helps you to select quickly with the mouse. In the selection bar, the mouse pointer will turn to an **arrow facing right** e.g. 

3.6 Active and Inactive Commands

Commands that respond immediately after they are chosen are active commands. They appear dark or blue in colour.

Commands that do not respond immediately when they are chosen are inactive commands. However they might be active after more actions have been performed. They are usually grey or white in colour.

The figure below shows examples of active and inactive commands.

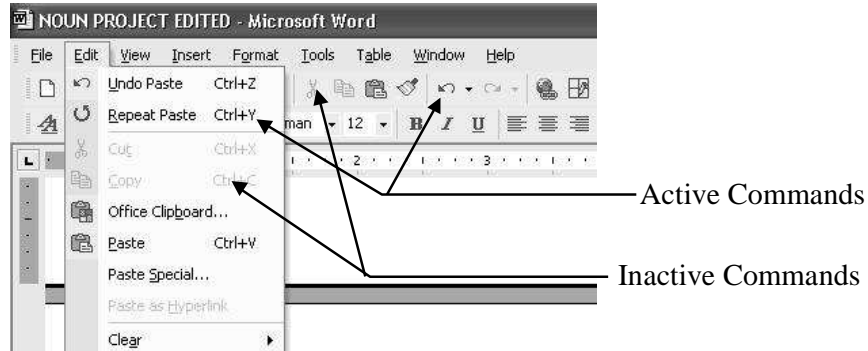

3.7 Page Setup

At times you begin a new document by setting up the page. That is by determining the type of paper (A4 foolscap Legal, envelop or any other types), the orientation of the paper (portrait or landscape), the margins to be left out on all sides of the selected paper etc.

Practice 4

How to setup Page

- Activate the **file menu**
- Click **Page Setup** to bring out the page set up dialog box like the one shown below:

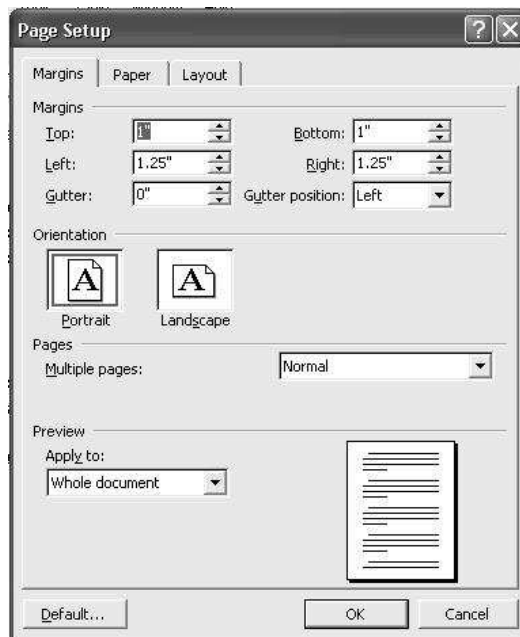

Margins allow you to setup appropriate margin to suit your task either by increasing or decreasing the margins at all sides of the paper.

Orientation gives you the possibility of printing on portrait or landscape shape of the paper.

Click on **Paper Size tab** in order to select the type of paper you would like to use e.g. A4, A3, B5 etc. Note that if printer is not installed in your system, the list of various sizes will not come up. Click on **Layout tab** to set Header and Footer

- Click on the **down facing arrow** on **Apply to** box to select **This Point Forward** if you do not want the settings to be applied to the whole document (for more than one page document)

- Click OK.

Note: It is not compulsory that you must carry out all the settings as explained above. Most often, it is the paper size that is always set on A4 size before you commence your work because it is the ideal printer paper size for most printers.

3.8 Keyboard Keys

This topic is brought here so that we may have the practical knowledge of most of the keys that we shall be using frequently. Therefore, try to identify the outlined keys on the keyboard first before you attempt to read its function or practise with it.

Computer keys: These are escape, Alt, Ctrl, Delete. Print Screen, Scroll Lock, Pause/Break etc. These keys are not found on the manual typewriter keyboard.

Function keys (F1-F12): Perform different task according to the application software in use. At times the Function Keys are used in conjunction with other keys in the keyboard.

Cursor or Arrow Keys: These are the Home, Page Up, Page Down, End, Home Keys and the 4 Arrow Keys. They are used to position the cursor on the screen. In other words, they are used for moving around in your document. They are also called the **navigator keys**.

Home and End Keys: Home key returns the cursor to the beginning or starting of the line while the End key returns the cursor to the end of the line.

Page Up and Page Down: Page up is used to move the cursor up one page while Page Down is used to move the cursor down one page.

The 4 Arrow Keys: Are used to move up and down or left and right between lines of texts and menus. They are also called the navigators.



The 4 Arrow Keys

Status Indicator (Light): The status lights are **3**, located at top extreme right of the keyboard. They display the status either on or off. They are **Caps Lock**, **Num Lock**, and **Scroll Lock**.

Caps Lock: Like other status indicators keys, the Caps Lock key is pressed to put it on or off. When it is on, all alphabetical characters will be capital letters and when it is off, all alphabetical characters will be small letters

Practice 5

How to use the Caps Lock Key

- Press the Caps Lock key and ensure that the light is on, then type **THE BOY IS COMING.**
- Press the Caps Lock key again and ensure that the light is off, and then type **the boy is coming.**

*Please do not mind if the first **letter T** is capitalized automatically because your system might be set on **Autocorrect***

Numeric/Direction Key Pad: The numeric keypad is like a portable calculator attached to the computer. The num lock light indicates that the **numeric numbers (0-9)** are active and when it is off, the **arrow keys** will be active instead. The numeric keypad allows you either to move the cursor or input numeric data.

Practice 6

How to use the Num Lock Key

- Press the Num Lock key if the light is not on already
- Type 1 2 3 4 5 6 7 8 9 10 11 12 to 40
- Press the Num Lock key to off it, then type 4 4 4 or 6 6 6 6 6 or 8 8 8 8

What do you notice? The cursor is now moving up/down, left/ right

Enter/Return Key: perform the follow functions.

It moves the cursor from the end of one line to the beginning of the next without getting to the right margin where the computer can wrap.

It is used to create more gaps between lines when the cursor is placed at back of the beginning of the line of text. 

In some keyboard it is marked with the sign:

Practice 7**How to use the Enter Key**

Type the following lines of text as they are. Please do not type the **instructions italicized and bold** at the end of each line.

Why are you leaving us behind? ***Press Enter key***

My dearest teacher of yesterday. ***Press Enter key***

The memory of your departure is very great, to me is agonizing!

Press Enter key

Each time I remember your love, the spirit of sorrow fills my mind.

- Place the cursor (i.e. I beam mark) at the back of the beginning of line 2 and it will be like this: (|My) flashing.
- Press Enter Key twice to create extra space. *Please hold on and go further.*

Backspace key: Is often referred to as the typing 'eraser'. The more it is depressed, the more character to its left are deleted. It is used to bridge abnormal gap between lines when the cursor is at the back of the beginning of the lines. Also, in some keyboard, it is mark with this symbol:

Practice 8**How to use the Backspace Key**

- Place the **cursor** (i.e. I-beam mark) at the beginning of **line 2** if it is not there already
- Press **Backspace Key** twice to bridge the space.

*If you press it further, it will join the first line, but you can press **Enter Key** again to take it to the second line.*

Deleted Key: It is used to erase character to the right of the I-beam cursor one character at a time. However it should not be taken to be the same thing with the BACKSPACE that is used to cancel the most recent operation.

Practice 9**How to use the Delete Key**

- Place the cursor between the words – **you** and **leaving** in line 1 as shown below:
Why are **you** | **leaving** us behind?
- Press Backspace Key to erase **Why are you** and press Delete Key to erase **leaving us behind**?

*The logic is to use **Backspace Key** while deleting to the left and use **Delete Key** while deleting to the right.*

Escape Key: it is used to cancel the current line or command when the enter key has not yet been pressed.

Shift Key: Allows you to type capital (upper case) or small letters (lower case). Also, it makes typing of upper keys special characters such as @, \$, % etc possible.

At time, it is shown on the keyboard by this symbol:

**Practice 10****How to use the Shift Key**

- Ensure that your Caps Lock is not on
- Hold the Shift Key to type A B C D E F, and release your finger and type a b c d e f, again.
- Hold the Shift Key to type! @ # \$ % + ?, release your finger and use the same keys to type 1 2 3 4 5 = /



Windows Key: With the indicator of the symbol functions as a start button on the task bar.

Practice 11**How to use the Windows Key**

- If your keyboard is windows keyboard, press the  **windows key** to activate the start button.
- Press **Esc (Escape) key** to remove the Start menu from the screen.

3.9 Creation of a New Document

In MS-Word, there are two types of document creation – **Template** and **Custom**. Template involves using a document format as a guide to the new document to be created, and a wizard do assist in the creation of the document. On the other hand, with Custom document, the designer determines entirely how he wants the document to look.

Now start working with MS-word by creating a custom document. Type the following passage. Do not attempt to edit the mistakes you may notice or format any text. We shall use it for practice. And after you might have typed some few lines, go to 3. 10 and practice how to save

Obedience Pays

In those days when men were living by might and power, when jungle justice was the order of the day, when lawlessness pervaded almost every society and trade was barter system; there came the colonial masters who claimed to salvage our fore-fathers from barbarism.

The colonial master brought a system of government that was completely alien to the pre-colonial era especially in the south west of the country. There was nothing like taxation i.e. poll tax in that part of the nation before the arrival of the colonial masters. The people saw it as a disguise means of extorting the hard Queen's coin; they couldn't even get after much sales. Therefore, they have to avoid paying tax by all means either by escaping through the jungles where their houses were part of in those days or comically, a man disguising himself by wearing his wife's attire and start doing some women domestic works; and he will pretend to be deaf and dumb if the tax collectors happen to ask him any question about the husband's whereabouts.

On the other hand, the tax collectors were so cruel to the extent that they will take away a child in place of his father if the situation permits. They were popularly known as '**Dogeni(s)**'.

One faithful day, Mr. Egbor went to farm with his two sons – Okha and Oshoke. All of a sudden the rain started falling heavily; therefore they ran to the little farm hut to take shelter. Father and sons were enjoying themselves with the warmth of the fire and fresh roasted corns, when four Dogenis drenched with the rain seeking for shelter, entered the hut. Unknowingly to the Egbors, the Dogenis used the smoke from the fire to trace the hut. And there was no way they could escape.

Dawn on Mr. Egbor, that they were inside the Dogenis' net; he entertained them with fresh corns to the extent that one of the Dogenis was carried away with deep sleep. Like a trapped bush fowl, Mr. Egbor thought of other strategies to escape. He told his first son – Okha to go and harvest more corns for the Dogenis, at the same time, he used non-verbal cues of the eyes to tell him to go home from there. Okha retorted by saying: *“I can't go. Don't you see that the rain is still drizzling?”* He did the same thing to Oshoke and he obeyed and went. After a while Mr. Egbor started shouting *“Oshokee... What are you doing there? Are you not seeing the corn to harvest?This useless boy!”* Subsequently, he told the Dogenis that he was going to check what was making Oshoke to delay. He zoomed off and met Oshoke at home.

The Dogenis waited and night was approaching after the rain had stopped. What do you expect them to do with Okha? Of course they took him away as ransom for his dad and brother.

This legend reminds me of a song my primary six (6) teacher taught us. It goes thus:

Obedience pays, humility pays.

They make you beloved to God and to man.

Pride and disobedient and dishonesty pay.

They make you be sorrow to God and to man.

3.10 Saving Documents (Files)

The recent Microsoft operating system offices have **Auto Recovery** to recover your document if there is power failure and there is no UPS to conserve power in order for you to save your document before shutting down the computer. However, it is a big risk because at times not everything you did is recovered. Therefore it is advisable to save your document after typing some few words in the hard disk which is the local disk you are working with; and create a back-up in other storage medium such as diskette, zip, flash etc.

Practice 12

How to save a File for the First Time in the Hard Disk

- Click on the **file menu**
- Click on **Save As** command. And the **Save As dialog box** such as the one below will come up.

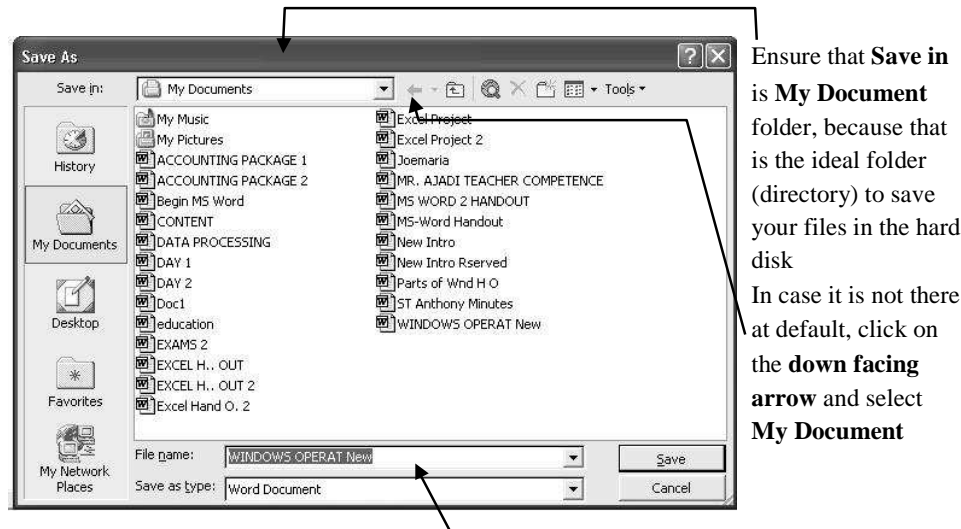

You will notice that the **file name box** contains the first few text of the first line you have typed. Ignore them and type your own file name; and you will see that everything will be deleted immediately you start typing.

You can also click on the file name box and use the eraser keys (backspace and Delete keys) to erase the text before typing your own file name

*You are free to use any name of yours to save the file but I would like to suggest that you use a common name (**MS-Word Tutor**) to save the file for easy reference.*

- Type the **name** of the file in the **file name box**.
- Click on **Save** or press **Enter key** on the keyboard. Then you will see the name on the **Title bar** and **Taskbar** respectively.

Subsequent Savings after the First Saving

If a document is already existing with a name in the system, there is no need to use the save as command to save additional or subsequent work you have done or doing on it. You can use any of the following methods to save the subsequent work done. However the third and second methods are frequently used.

- Activate the **file menu**
- Click on **Save** command.

Optional Method 1



- Click the **Save Icon** on the standards tool bar

Optional Method 2

- Press **Ctrl + S**

3.11 Closing/Quitting Documents (Files)

Every application programme is closed and quit before the system is shut down in order to avoid unnecessary message.

Practice 13

How to close and quit a File

- Click on the **close button**  in the document window and Microsoft window respectively to quit the document

Please consult windows operating System in unit 2 above if you have forgotten the close buttons.

3.12 Opening of Files saved in the Hard Disk

The open command is used to retrieve files saved in the hard disk There are many methods you can use to open your files saved in the hard disk and the following open dialog box will appear no matter whichever method you applied. Some of them are as follows:

Practice 14

How to open or retrieve a File in the Hard Disk

We shall use the file (MS-Word Tutor) we have saved to practise

To open through the Application window

- Load the **Application Programme** (in this case MS- word).
- Activate the **File Menu** and click on Open command. Or Click on **Open Icon**  on the **standard tools bar**. Or Press **Ctrl + O** from the keyboard.

The open dialog box such as the one below will appear no matter which of the three options you employed.

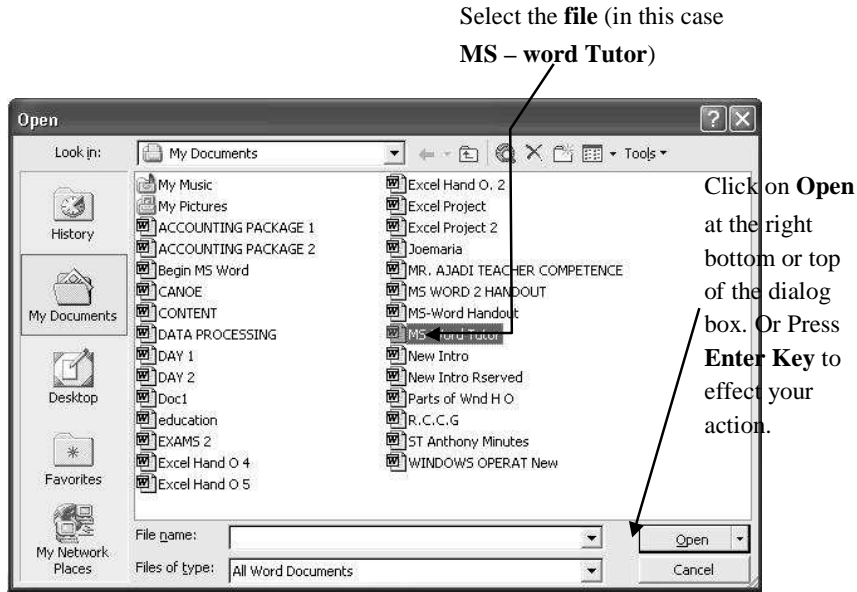

Optional Method 1 – To open through My Documents Icon on the Desktop

- Open my **Documents Icon** to show you my Documents window such as the one below:

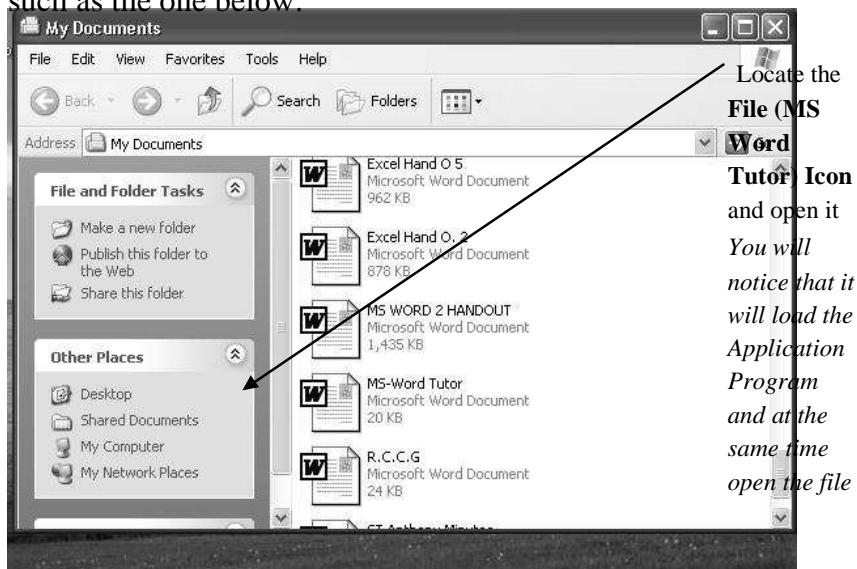

Optional Method 2 –Through the Task Pane

If you are using the recent versions of windows, e.g. XP, you will notice the appearance of a **task pane** either at the right or left of the document window every time you load MS-Word; and it will contain some of the recent files you have saved.

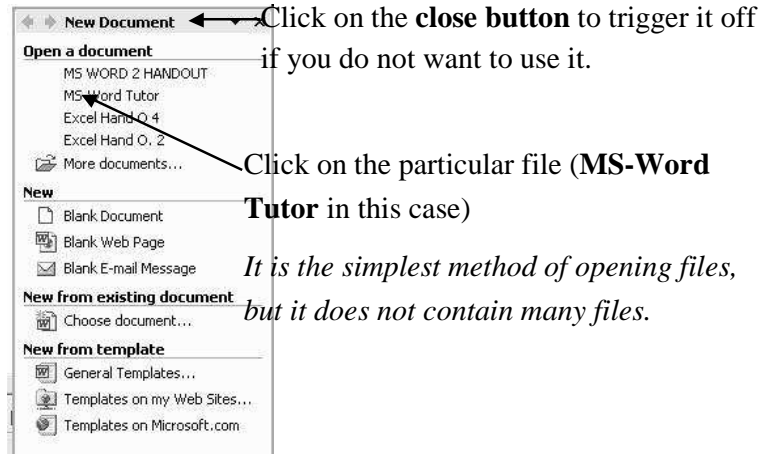

Task Pane

3.12 Saving File/Folders in Other Storage Mediums E.G. Diskette, Zip Disk and Flash Disk

Files/folders in the hard disk are copied into other storage mediums such as diskettes, Zip Disks, flash disks, compact disks etc in order to transfer them to another computer or for making back-up of data files.

Note that you can copy a file into the CD if your computer has CD Read/Write disks and drives in order to read from and write to CD. CD-RW disk is relatively slow when data are being written to it.

Also, it is important to note that Windows 98 does not have facilities for **flash disk**; and you may not be able to use flash disk even though your system has the recent Windows O.S. and there is no provision for the flash drive too.

We have several methods of copying files and folders into other removable disks, but only one method that has no restriction is considered here.

Practice 15

How to save (copy) a File in the Hard Disk into a Diskette or Flash Disk

Using My Documents Icon on the Desktop

- Slot or plug the **disk** into the appropriate drive

*Note that the port for flash drive may be at the back or sides of the CPU.
And after you have plugged a flash disk, the icon will appear on the notification part of the task bar.*

- Open **My Document icon** on the desktop

My Documents window such as the one below will appear:

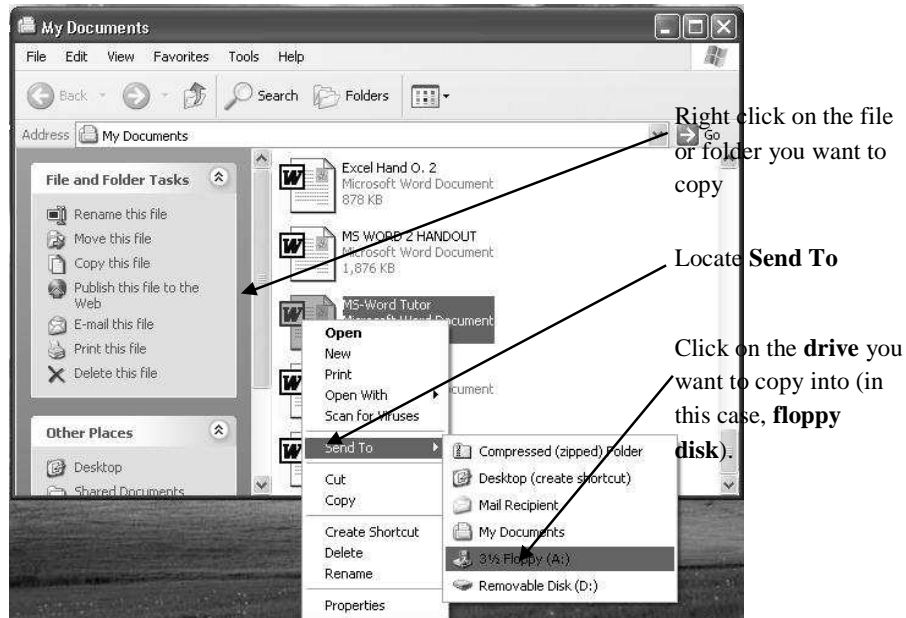

You might have noticed here that my **flash drive** is represented by **Drive D** i.e. **D:** This is because there is no Compact Disk drive in my system. Yours might be E: or F:, depending on the available disks drives in your system.

Practice 16

How to retrieve or open a File in the Diskette or Flash Disk

From My Computer Icon on the Desktop

- Open **My Computer icon** at the Desktop to bring out My Computer Window like the one below.

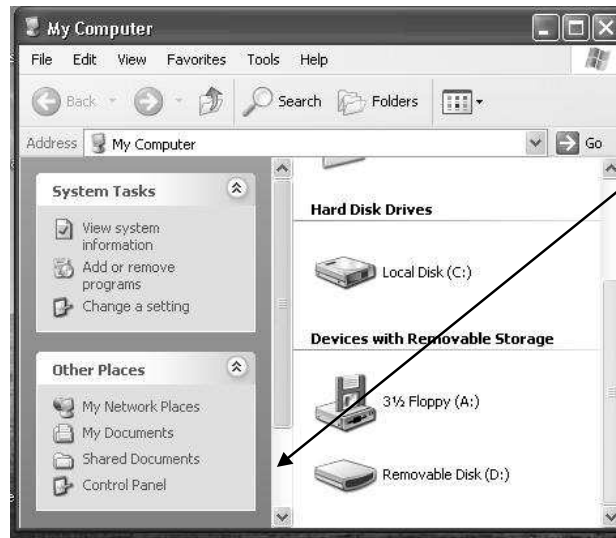

Open the **removable disk Icon** (in this case – the **flash disk**)
Then you will see its content just like the one shown below

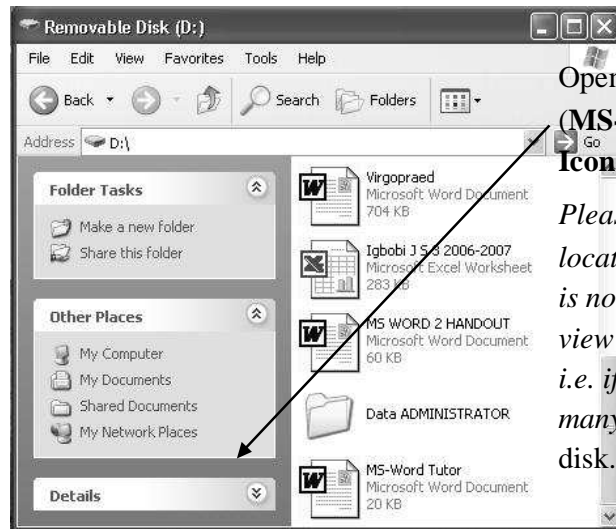

Open the **File (MS-Word Tutor) Icon**
Please scroll to locate the file if it is not at instant view of the window i.e. if you have many files in your disk.

Note: Remember to close the windows of all removable disks that you have opened before you remove them from their disk drives. And if you want to unplug the flash disk before you shut down the system, you do that through its icon on the taskbar as explained below:

> Click on the **show hidden icons** button if the flash icon is not visible at the notification area of the taskbar.



> Use the **mouse pointer** to point at it to ensure that it is the **flash icon** before you click on it to get a **message** such as the one on the taskbar below, depending on the type of flash you are using.

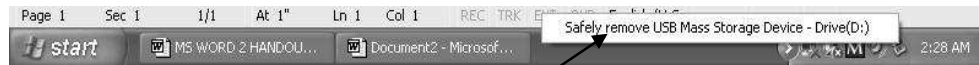

> Click on the **message** in order to get the final message that will permit you to remove the flash disk



The above **message** may appear pointing to the icon as indicated above or it may appear at the center of the screen. It depends on the method you employed



4.0 CONCLUSION

It is ideal in MS-Word that the page is set up before you attempt to create a document

5.0 SUMMARY

Back-up disks are very essential for files transfer from one system to another, and also guarantee safety of files in case the hard disk or the entire system develops faults which might be irreparable.

6.0 TUTOR-MARKED ASSIGNMENT

1. Mention some keys that are peculiar to a computer keyboard that are not in the manual typewriter keyboard.
2. The following symbols signify which key on the keyboard?
 - i)   
3. Mention the eraser keys on the keyboard and explain to novice how he/she can use them.
4. List any three external hard disks you can use as back-up for your files.

7.0 REFERENCES/FURTHER READINGS

Ian Ithurralde, Anne Ramkaram, *This is IT 2*, Second Edition.

French, C.S (2000). *Computer Science*, Asfifor Colour Press: Gosport Hants, 5th Edition.

UNIT 4 MICROSOFT WORD (MS-WORD)

CONTINUED: TEXT FORMATTING AND EDITING

CONTENTS

- 1.0 Introduction
- 2.0 Objectives
- 3.0 Main Content
 - 3.1 Selection of Text
 - 3.2 Text Formatting
 - 3.2.1 Font Type, Size and Style
 - 3.2.2 Text Alignment
 - 3.2.3 Dropped Capital
 - 3.2.4 Change Case Command
 - 3.2.5 Line Spacing Command
 - 3.3 Text Editing
 - 3.3.1 Spelling and Grammar
 - 3.3.2 Synonyms (Nearest in Meaning) of Words
 - 3.3.3 Find, Replace and Go To Commands
 - 3.3.4 Copying, Cutting and Pasting Text
 - 3.3.5 Undo and Redo Commands
 - 3.3.6 Page Numbering
 - 3.3.7 Header and Footer
- 4.0 Conclusion
- 5.0 Summary
- 6.0 Tutor-Marked Assignment
- 7.0 References/Further Readings

1.0 INTRODUCTION

This aspect of MS-Word teaches you how to work with text in terms of formatting and editing to make the document look very attractive and free of many errors.

2.0 OBJECTIVES

At the end of this unit, you should be able to:

- use mouse to select text
- format text in terms of font type, size, style, alignment etc.
- spell check a document
- find and replace text and find synonyms of words
- space lines of text
- copy, cut, and paste text
- redo and undo commands
- insert page Number and create header and footer.

3.0 MAIN CONTENT

3.1 Selection of Text

In order to specify where you want your action to take place, the text must be selected or highlighted.

Practice 1

How to use the Mouse to select

- Load **MS-Word** and open the **file (MS-Tutor)** containing the passage – Obedient Pays.

Let us use the heading – Obedient pays to practice.

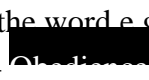

To select single word or text e.g. Obedient

- Place the **cursor** on any where in the word e.g. Obedience and **double click** to get result like this – 

How to erase any selection

- Click outside the **selection** or press any **arrow key** on your keyboard.

To select multiple texts or lines of texts

- Place the cursor like this –  **Obedience Pays**, then click and hold down the mouse button and drag  **nce Pays** to the right to give you this result –  . Or place your cursor like this – **Obedience Pays** and drag to the left

To use the mouse to select a large portion of the passage or the whole passage

- Place the cursor at the beginning or end of the portion and drag **left up** or **right down**.

Place it at the end of the first paragraph like this as shown below:

In those days when men were living by might and power, when jungle justice was the order of the day, when lawlessness pervaded almost every society, and trade was barter system; there came the colonial masters who claimed to salvage our fore fathers from barbarism.

- > Click and drag to the left to select the **last line** and then **go up** to select the others to get result like this:

In those days when men were living by might and power, when jungle justice was the order of the day, when lawlessness pervaded almost every society, and trade was barter system; there came the colonial maste

How to use the Selection Bar to select

- Move the **mouse pointer** to the **selection bar** and ensure that you are at the beginning of the line, then you will notice that the pointer will turn facing the line of text just as the one shown below pointing to the first line of the passage.

In those days when men were living by might and power, when jungle justice was

- Click to select the **whole line**. And to select other lines at the top or bottom, hold down the mouse button and drag **up** or **down** as the case may be.

To highlight the entire document with the mouse

- Hold down the **Ctrl** key and click any part of the **Selection bar**.

***Note:** Remember that the selection bar is the space between the left margin and the vertical ruler where the mouse pointer will be facing right pointing to the line of text. See MS-Word Screen Layout.*

How to use the Keyboard to select

To select	Press
One character to the right	Shift + Right Arrow keys
One line down	Shift + Down Arrow keys
One line up	Shift + Up Arrow keys
Whole document	Ctrl + A

***Note:** Wherever you see commands such as the above commands, it means that the first key e.g. Shift key/Ctrl key is held down while the other key is tapped. And if the keys are three (3), you hold the first two (2) keys down, and then tap the last key. For instance, Ctrl + A, implies holding **Control** key down, and then tap **A** key;*

Practice 2**How to use the Keyboard to select**

Practice with the first line of the passage

- Place the cursor between **were** and **living** as shown below:

In those days when men were living by might and power, when jungle justice was

To select – ~~were men when days these In~~

- **Hold down the Shift key and start taping the Left Arrow key, or hold it down to select fast.**

To select - ~~living by might and power, when jungle justice was the~~

- Hold down the **Shift key** and start taping the **Right Arrow key**, or hold it down too to select fast.

3.2 Text Formatting

Text formatting involves all the techniques that are employed by the user in order to change the appearance of text to suit his own taste in form of character (font) type, size, colour, style e.g. bold, italics, underline alignment etc.

In case you want to remove the format that you have applied, click or press the particular button or key you have used to apply it. Also, if it is applied through the dialog box you can use the same dialog box to place it back at default.

3.2.1 Font Type, Size and Style

At default MS –Word's font type is **Times New Roman**, and the font size and style are on **normal (12)** and **regular** respectively.

Practice 3**How to change Font Type**

Load **MS-Word** and open the **file (MS-Word Tutor)** containing the passage – Obedient Pays

- Select the heading – **Obedience Pays**
- Activate the **Format menu**, click on **Font** command

- Click **Font Tab** if it is not already opened

The Font dialog box such as the one below will appear

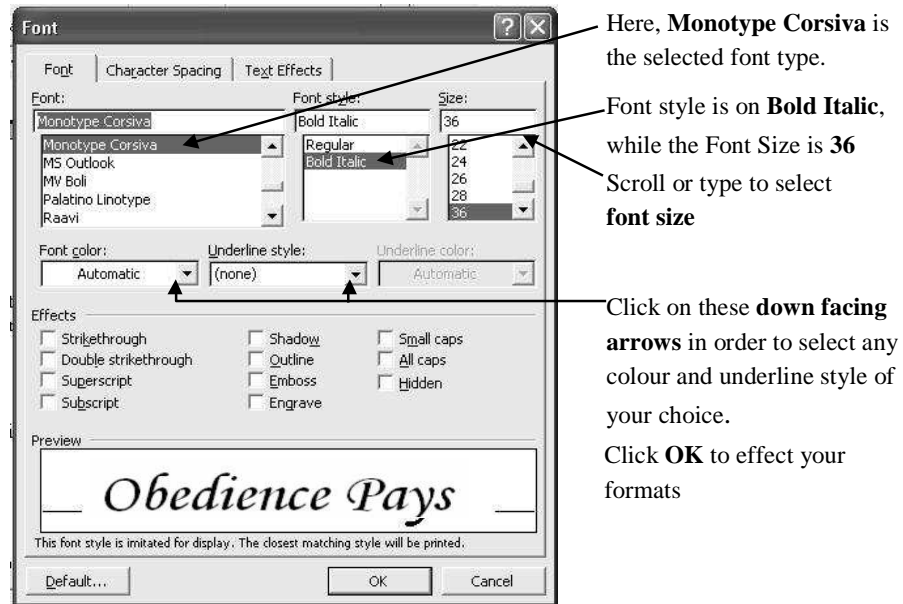

Here, **Monotype Corsiva** is the selected font type.

Font style is on **Bold Italic**, while the Font Size is **36**
Scroll or type to select **font size**

Click on these **down facing arrows** in order to select any colour and underline style of your choice.

Click **OK** to effect your formats

Is your result like this? *Obedience Pays*

Optional Method – Using the Formatting Tools Bar

- Highlight the **text**



Click on the **down facing arrow** to select any font size from the list of options

You can erase the default size and type the one not on the list. But you have to press **enter key** to effect your changes.

Click on **B, I, U**, to apply either **bold, italics** or **underline** to the selected text.

Click on the **down facing arrow** to apply any font colour of your choice.

3.2.2 Text Alignment

Alignment command positions selected texts of the document to specified part of the page. A text or paragraph can be aligned in four major ways left, center, right and justify

Practice 3

How to align Text

Using the Formatting Tools Bar

- Select the heading – **Obedient Pays**
*Please point the **mouse pointer** to each button to know its name*

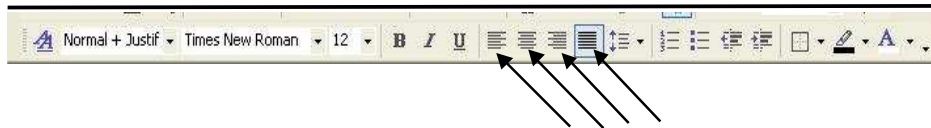

- Click on any of the first three **alignment buttons** on the **formatting tools bar** to see how the heading could be aligned to the **left**, **center** and **right** of the page. Finally align it to the **center** of the page.

Optional Method – Using the Keyboard

- Select the **texts**
- Press **Ctrl + L** for Left alignment
- Press **Ctrl + R** for Right alignment
- Press **Ctrl + E** for Center alignment
- Press **Ctrl + J** for Justify alignment.

Note that Justify's effect is noticed when you have multiple of text e.g. a page or more. It makes text to occupy the full width of the selected paper.

3.2.3 Dropped Capital

Letter (character) starting the first word in a paragraph of texts can be dropped by a number of specified lines to give a magazine look. When text is dropped, the character becomes bigger longer in height than text on the same line.

Practice 4

How to make Text a Drop Cap

- Select the **text** e.g. **letter I** at the beginning of the first line in the first paragraph
- Click on the **format menu**

- Choose the **Drop Cap** to give you the drop cap dialog box as follows:

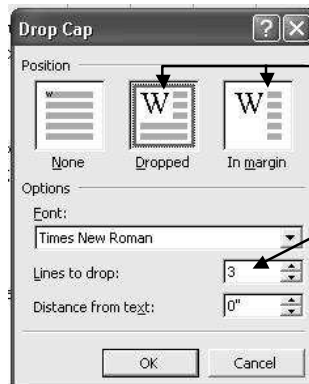

Click on either **Dropped** or **In margin** icon to select the type of drop cap. In this case, **Dropped** is selected.

Type the **number** or scroll to select the number of lines to drop. In this case three lines are dropped.

Click on **OK** to effect your format; and then check if your format looks like the one below.

In those days when men were living by might and power, when

jungle justice was the order of the day, when lawlessness pervaded almost every society and trade was barter system; there came the colonial masters who claimed to salvage our fore-fathers from barbarism.

How to remove a Dropped Capital

- Select the **text** and follow the procedure of how to apply it above
- Click on the **None** icon, and click on the **OK** button.

3.2.4 Change Case Command

It allows a user to switch between texts cases i.e. **upper**, **lower**, **sentence**, **title** and **toggle** cases. No matter which case you use to type your document, you can change it later to the desired case.

Uppercase makes every selected text capital letters. Lowercase makes every text small letters; and sentence case capitalizes the first letter in a sentence and makes the others small letters just as in normal sentence. Title capitalizes the first letter of each word in a selected line(s) of texts, while toggle changes the first letter of the first word in all the selected

sentences to small letters and capitalizes the rest. Note that title and toggle are not frequently used.

Practice 5

How to change Case using the format menu

- Highlight the **first paragraph** of the passage in **Ms-Word Tutor file**

- Click on the **format menu** and from the sub menu, click on **change case** command

The change case dialog box like the one below will appear:

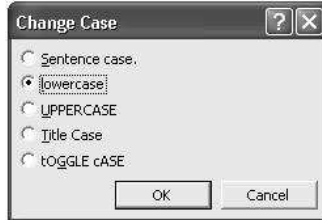

> Click on any **case** you want to change to, and then click on **Ok** to see the result

Optional Method – Using the Keyboard

- Highlight the **texts** as in first method
- Press **Shift + F3** intermittently until your format is on the intended one

*Note: Second method only allows you to get **upper**, **lower** and **sentence** cases; as you press the keys, it moves from one case to the other.*

3.2.5 Line Spacing Command

By default, word single spaced lines of text and automatically adjusts line heights to accommodate graphics of large or smaller sizes. Custom spacing can improve the look of the document.

Practice 6

How to set Line Spacing using the Format menu

- Select the **paragraph**, **page** or the **whole document** you want to adjust. In your case, select the **whole document**
- Activate the **Format menu** and choose **Paragraph** to give you the paragraph dialog box such as the one below:

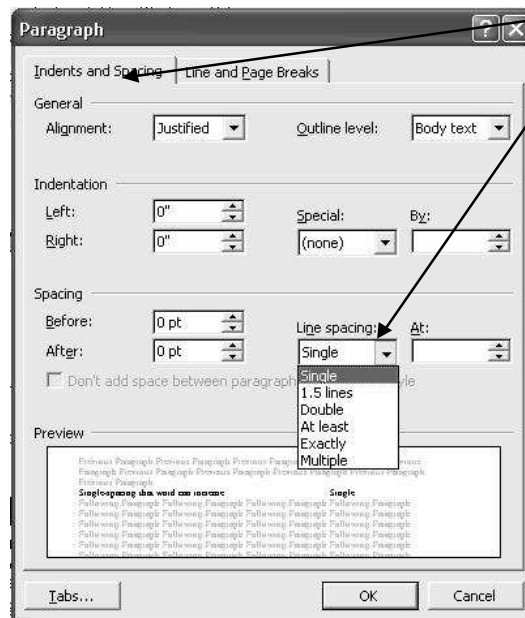

Click **Indents and Spacing** tab if it is not opened already

Click on the **down facing arrow** by **line spacing box** to select one of the options:

Single i.e. Single-spacing that Word can increase (Word here refers to MS-Word)

1.5 lines i.e. One- and -a-half line spacing that Word can increase

Double i.e. Double-spacing that word can increase

At least i.e. The minimum line spacing that Word can increase

Exactly i.e. Fixed line spacing that word does not adjust

Multiple i.e. At most line spacing that word can increase

Optional Method – Using the Keyboard

- Select the **paragraph**, **page** or the **whole document** you want to adjust

For This Format

Single-spaced lines

Double-spaced lines

One-and-a-half-spaced lines

Press

Ctrl + 1

Ctrl + 2

Ctrl + 5

3.3 Text Editing

Text editing is a way of using all the necessary tools to give precision to a document.

3.3.1 Spelling and Grammar

Is often said, “no one is above mistake”. A user can wrongly spell a word in the document either due to speed or by placing hand on a wrong key.

When typing on document, word uses **wavy red underlines** to indicate possible **spelling errors** and **wavy green underline** for possible **grammatical error** in view of the computer’s dictionary. Therefore any word e.g. vernacular or British spellings underlined; and grammar that is

correct but underlined should be ignored. The best way to correct spelling and grammatical errors in the document is by running spell check on the texts in the document.

Practice 7

How to spell check a Single Word

Move your cursor to the word e.g. **coonial** in the third line of the first paragraph and right click to pop out a menu like the one below:

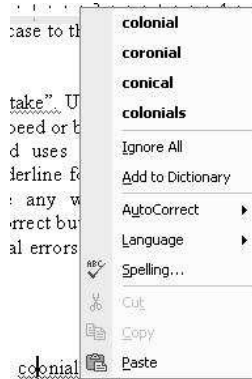

> Locate the **correct spelling** from the suggested list of words; if it has more than one and then click on it.

Practice 8

How to spell check Multiple Words (Whole Document)

Using the Tools menu

- Ensure that the **cursor** is blinking inside the document
- Activate the **Tools menu**
- Click on **spelling and grammar** to bring out the **spelling and grammar dialog box**.

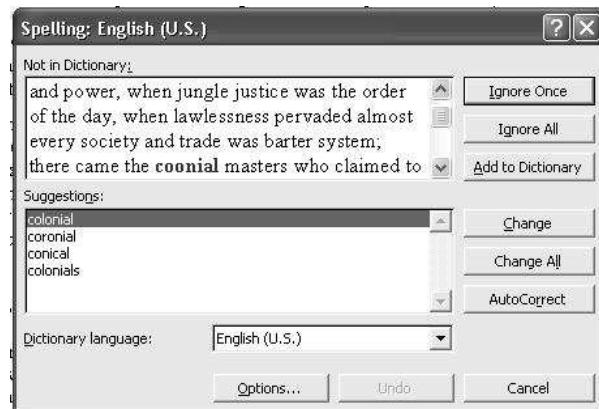

> Click on **Ignore Once** if the displayed word is correct but not recognize by computer dictionary; click on **Ignore All** if the highlighted word is more than one in the document.
> Click on **Add to Dictionary**, if you intend to include the selected word into the computer dictionary

- Click on **Change** to correct the wrongly spelt word to suggested word by computer; click on **Change All** to change subsequent appearance of the highlighted word.

- Click on Auto Correct to correct the displayed word manually.



After you have finished spell checking the whole document, a message such as the one by the left may come out to alert you about the completion of the spelling exercise.

Optional Method 1 – Using the Keyboard

- Place the **cursor** at anywhere in the passage and Press **F7** key

The dialog box in 1st method will appear.

Optional Method 2 – Using the Standard Tools Bar

- Place the **cursor** at anywhere in the passage
- Click on **Spelling and Grammar icon**  on the **standard tools bar**

The dialog box in 1st method will appear.

3.3.2 Synonyms (Nearest in Meaning) of Words

Thesaurus is used to find synonyms of words. It is used to improve the precision and variety of your writing.

Practice 9

How to check synonyms of a Word

Right Clicking on the Word

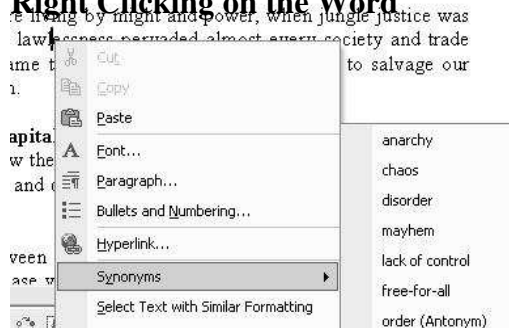

> Right click on the particular word e.g. **lawlessness** in the first paragraph of **MS-Word Tutor** passage as indicated here

> Locate **Synonyms** and you will notice the pop up of various possible nearest in meaning to the word you right clicked on.

> Click on any **word** you would like to use to replace the original word

Optional Method – Using the Tools menu

pecially in the south west of the country. There was not in that part of the nation before the arrival of the colonia



- > Select the word e.g. **arrival** in the second paragraph of MS-Word Tutor passage as indicated here
- > Activate the **Tools menu** and point to **Language**
- > Click on **Thesaurus** to give you the dialog such as the one by the left.
- > Select the **required word** in the pane under **Replace with Synonym** if you want to replace the selected word
- > Click **Replace**

3.3.3 Find, Replace and Go To Commands

These three commands are very useful in a document that has many pages. **Find** will show the word to you, wherever it is in the whole document but cannot replace it; while **Replace** will help you to find the word and at the same time change it to the intended word typed in the Replace box. Go To on the other hand, helps you to go to a specified page, section, line, footnote etc in the document

Practice 10

How to replace Words in a Document

- Activate the **Edit menu**
- Click on any of the three commands i.e. **Find**, **Replace** and **Go To**

Find and Replace dialog box such as the one below will come out

The screenshot shows the "Find and Replace" dialog box with several annotations. At the top, there are tabs for "Find", "Replace", and "Go To". The "Find what:" field contains "Dogenis" and the "Replace with:" field contains "Police". At the bottom, there are buttons for "More", "Replace", "Replace All", "Find Next", and "Cancel".

- Click **Replace tab** in case you used **Find** or **Go To** to bring the dialog box out
- Type in the **word** to find in this case **Dogenis**
- Type in the **word** to replace with in this case **Police**
- Click on the **More button** to restrict the find what. Here you can give specification based on the options.
- Click on **Replace button** to make just only one replacement in the document
- Click on **Replace All button** to make all replacement in the document. Please apply on this option

3.3.4 Copying, Cutting and Pasting Text

As you edit your document, you often find it necessary to copy or cut texts or graphics and paste them somewhere else in the document. Text that you copied or cut is placed on the clipboard.

Clipboard is a temporal storage area that accommodates anything be it an object, text or graphic that is cut or copied using the cut and copy command from the standard tools bar or the edit menu.

The clipboard does not accommodate more than one content and it is volatile; which means that it losses its contents when there is power failure. Therefore, whenever you apply the copy or cut command, try to apply the paste command immediately to complete your action. Also, it only operates in windows environment.

***Note:** Cut removes the selected text from the document and stores it in the clipboard, while copy sends a duplicate copy of the selected text from the document and stores it in the clipboard. In other words, cut removes the selected text(s) or object(s) while copy duplicates the selected text(s) or object(s)*

Practice 11

How to copy Texts or Graphics using the Standard Tools bar

- Select the **texts** (in this case the **first paragraph** of **Ms-Word Tutor**)



Click on **cut icon** if you want to remove the original paragraph from where it is.

Click on **copy icon** if you want to retain the original paragraph and send a duplicate copy elsewhere

Click on the **paste icon** after you have position the cursor at the current place where you want the paragraph to be e.g. at the end of the page

Let us paste what we have on a new sheet. And to get a new sheet, click on the **New Blank Document icon** on the **standard tools bar**. As you can see from the standard tools bar above, it is the first icon

***Note:** Try to use the undo command to get the paragraph back after using the cut and paste command. (see practice 12 below)*

Optional Method – Using the Keyboard

- Select the **texts**

For this Texts Editing

Cut

Copy

Paste

Press

Ctrl + X**Ctrl + C****Ctrl + V**

3.3.5 Undo and Redo Commands

Undo and Redo commands allow you to reverse in both ways any most recent action such as deleting, cutting, copying or closing most Word's commands. You might click what you are not supposed to click; choose the undo command as the next action and if you want to reverse it again, choose the redo command.

There is limit to undo and redo commands depending on how your computer is configured. Whenever they are inactive, that means you cannot cancel your last changes or actions.

Note that there is no need for selection before you use these commands. Selection is applied below in order to delete the texts so that you can know the action of the commands when mistakes are made.

Practice 12

How to undo and redo Commands using the Standard Tools bar

- Select the **text** (in this case the **heading – Obedient Pays**)
- Press **Delete key** on the keyboard.



Click on **undo icon** to bring back the deleted text

Click on **redo icon** to reverse the action again i.e. deleting the text

Optional Method – Using the Keyboard

For this Texts Editing

Undo

Press

Ctrl + Z

Redo

Ctrl + Y

3.3.6 Page Numbering

Page Numbers Command is used to apply page numbering automatically either through the insert menu or header and footer under view menu to the document.

Practice 13

How to insert Page Numbers

- Click on the **Insert menu**
- Choose **Page Number** command. And the *page numbers dialog box such as the one below will come out:*

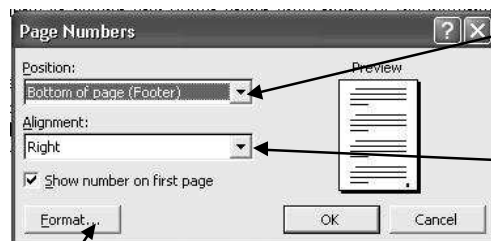

Click on the **down facing arrow** by **position box** to change the position to **Top of page** or **bottom of page**

Click on the **down facing arrow** by **Alignment box** to change the alignment to either right, center or left of the page

Click on **format tab** if you want to change the style of the numbering. For example, you can change the Arabic numeral which is the default to upper roman, lower Roman Upper alphabet lower alphabet.

The Page Numbering Format dialog box like the one below will come up:

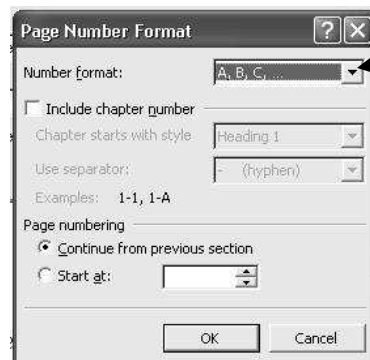

Click on the **down facing arrow** to change the numbering format to any one of your choice. In this case **upper alphabet** is chosen

3.3.7 Header and Footer

A header or footer is a text, which appears at the top or bottom of every page a bit above the top or bottom margin. Headers and footers often include such information such as document title, section or chapter title, date and time document was created, page number etc. What are the header and footer of this training manual?

Practice 14

How to create Header or Footer

Let the header of your document contain the page number, placed at the center and the footer should contain your name placed at the right margin

- Click on the **View menu**
- Choose **Header and Footer** command.

You will notice that the document will be dimmed and the header and footer tools bar will come out as follows:

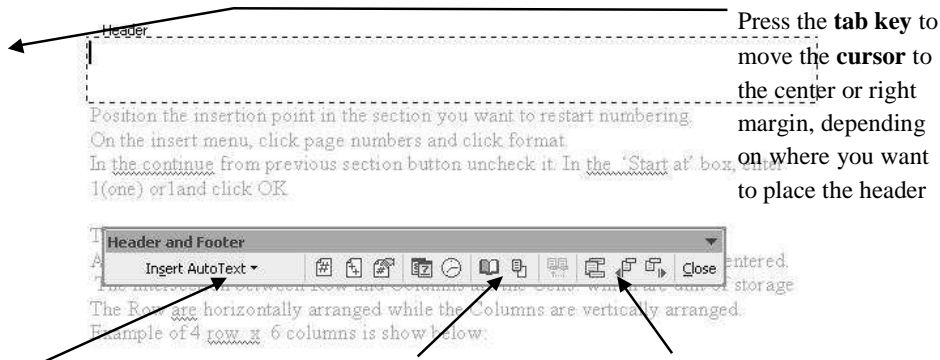

Click on **insert page number icon** to insert page number

Click on **switch between header and footer icon** if you want to go to the footer section, and vice versa

Click on **close button** to go back to your normal page

- Type header information such as chapter. name, page number etc.
- To create footer, click the **switch between header and footer icon** on the header and footer tools bar to move to footer area.
- Click **Close** on the **header and footer tools bar** when you are through.

HINT: On the footer and header tool bar, you can click to insert page number using '#' button; current date, time auto text etc for example to insert Running –Total number, such as “page 3 of 20” click insert Auto Text. And click page X of Y.

4.0 CONCLUSION

With MS-Word, text could be formatted to give the user what he expected, for instance, a user may decides to type a document in lower case and change it to upper case later. Also, there is room for editing, for example, when mistakes are made, the undo and Redo command could

be used to reverse the action or copy / cut and paste text at desired places.

5.0 SUMMARY

The Formatting tools bar provides icons as shortcuts for formatting text, while the standard tools bar provides shortcuts for editing text.

6.0 TUTOR-MARKED ASSIGNMENT

1. How do you select a single word with the mouse?
2. Interpret the following commands
 - i) Ctrl + C ii) Ctrl + X iii) Ctrl + V iv) Ctrl + Z
 - v) Ctrl + Y
3. Write short notes on the following
 - i) Clipboard ii) Undo and Redo commands
 - iii) Header and Footer
4. How do you spell check a single word?
5. Mention the keyboard shortcut for double and single spacing of lines.

7.0 REFERENCES/FURTHER READINGS

French, C.S (2000). *Computer Science*, Asfifor Colour Press: Gosport Hants, 5th Edition

Petroleum Training Institute (PTI), (1999). *Lecture Manual on Word Processing*, Warri.

**UNIT 5 MICROSOFT WORD CONTINUED:
TABLES IN MS-WORD****CONTENTS**

- 1.0 Introduction
- 2.0 Objectives
- 3.0 Main Content
 - 3.1 Tables in Word
 - 3.2 Entering Text into a Table
 - 3.3 Table Selection
 - 3.4 Adding (Inserting) New Rows and Columns to a Table
 - 3.5 Deleting Table, Rows and Columns
 - 3.6 Text Orientation (Direction) and Alignments in a Table
 - 3.7 Adjusting Row Height and Column Width
 - 3.8 Moving Table
 - 3.9 Sorting Table Data
 - 3.10 Splitting Table Cells
 - 3.11 Table Borders
- 4.0 Conclusion
- 5.0 Summary
- 6.0 Tutor-Marked Assignment
- 7.0 References/Further Readings

1.0 INTRODUCTION

This part of word processing teaches you how to disseminate information with a table.

2.0 OBJECTIVES

At the end of this unit, you should be able to:

- insert table and enter text into a table
- select table and other parts such as columns, rows and cells
- insert and delete columns and rows whenever there is need
- direct text in table's cells vertically and alignment cells entries
- adjust row height and column width to fit the text
- know how to sort table data either in ascending or descending order
- split/merge table's cells to give more information.
- apply borders to a table.

3.0 MAIN CONTENT

3.1 Tables in Word

A table is made up of Rows and Columns where different related fields are entered. The intersection between Rows and Columns are the Cells which are units of storage. The Rows are horizontally arranged while the Columns are vertically arranged.

Most often, it is convenient to represent information in a table for more clearance. However, table in MS-Word is similar to Ms-Excel, therefore what table can do in MS-Word, can be done more conveniently in MS-Excel. See example of 4 rows by 6 columns table is shown below:

Practice 1

How to insert Table using the Table Menu

- Load **Ms-Word** or click on the **New Blank Document icon** on the **standard tools bar** if you are working on any other document in order to get a **new sheet**.



New Blank Document icon

- Position the **insertion point** where you want the table to be
- Activate the **Table menu**
- Locate **Insert** and click on **Table**.

The Insert Table dialog such as the one below will come out.

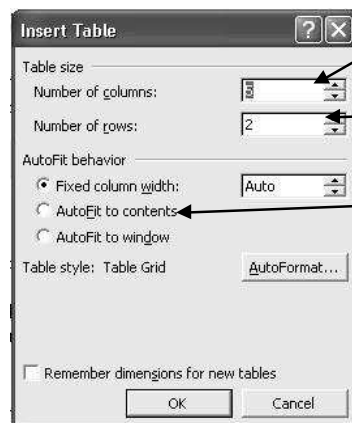

Type or scroll to get the **number of columns**. In this case, 7 entered for columns.

Type or scroll to get the **number of rows**. In this case, 2 is entered for rows.

Autofit to content is selected if you want the rows/columns to adjust automatically to fit the content of the cell as you are entering the data.

Click OK to insert the table

	Column		Column		
Row 1		2			6
Row 2					
			Cell		
Row 7					

3.2 Entering Text into a Table

Anytime you want to enter data into a table, click on the particular cell and start what ever you want to type. And to move within the cells vertically and horizontally, use the navigator keys. You can also use the Tab key to move horizontally.

Practice 2

How to enter Text into a Table

- Insert a table of **4 x 5** i.e. **4 rows 5 columns** like the one below and enter the data therein.

NAMES	MATHEMATICS	ENGLISH	GEOGRAPHY	AGRIC. SC.
Iredia Austine	54	62	48	53
Onome Ejiro	65	81	74	65
Abdul Hassan	84	62	51	80
Bayo Tunde	45	56	65	70

- Save the **file with a name** for future reference e.g. mine is saved thus – **Primary 4 Table**.

3.3 Table Selection

Just as the same way you select text before formatting, the whole table or parts of the table is/are selected or highlighted to give you way to carry out any format you want to make.

Practice 3

How to select Table's Column

- Take the mouse pointer to the **top of the column**, and when it turns to this shape  , then you click to select.

*And to select more than one column, **hold down the mouse button** after you have selected the first column and drag to the left or right to select the adjacent columns*

Practice 4

How to select Table's Row

- > Take the mouse pointer to the **selection bar**, and when it turns to this shape  , then you click to select.

*And to select more than one row, **hold down the mouse button** after you have selected the first row and drag to the top or bottom to select the adjacent rows*

Practice 5

How to select a Single Cell

- Move the pointer to the **left bottom right-angle** of the cell along the left edge and click when it turns to this shape  , click to select.

Practice 6

How to select the Whole Table

- Select either the **first** or **last column**, then drag across to select others to the end
- Or
- Select either the **first** or **last row**, then drag across to select others to the end
- Or
- Click on **Select All button**.

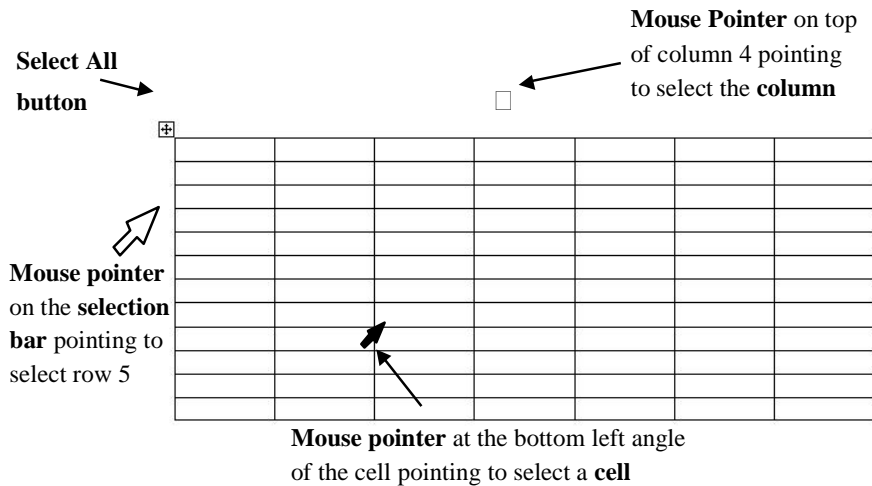

Note: You will notice a dark or bluish colour on any selected part of a table.

3.4 Adding (Inserting) New Rows and Columns to a Table

At times there is need for you to add more rows or columns to a table in order to add more data or information.

Use the following information to practice

Insert a row to enter Peter Ajala's data whose records are: Maths 58; Eng 73; Geo 47 Agric 62 between Onome Ejiro and Abudul Hassan i.e. 3rd and 4th rows. Also insert a column between Geography and Agric Sc. i.e. 4th and 5th columns to enter the follow scores from top to bottom – 39; 65; 59; 47 and 68 for **Music**.

Practice 7a

How to insert Row(s)

- Select the **Row** (in this case either **3rd** or **4th row**)
- Activate the **Table menu** and locate **insert**
- Click on **Rows Above** or **Rows Below**.

Practice 7b

How to insert Column(s)

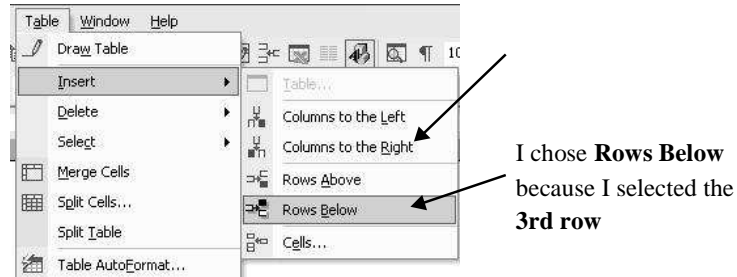

- Select the **Column** (in this case either **4th** or **5th column**)
- Activate the **Table menu** and locate **insert**
- Click on **Columns to the Left** or **Columns to the Right**.



You now have a similar table like the one below; then enter the data supplied above.

NAMES	MATHEMATICS	ENGLISH	GEOGRAPHY		AGRIC. SC.
Iredia Austine	54	62	48		53
Onome Ejiro	65	81	74		65
Abdul Hassan	84	62	51		80
Bayo Tunde	45	56	65		70

Optional Method 1

- Select the **Row** or **column**
- From the standard Tool bar click **Insert Rows icon**  or **Insert Columns icon** 

Optional Method 2

- Select the **Row** or **Column**
- Right click on the selected **Row** or **Column**
- Click **Insert Rows** or **Insert Columns** as the case may be.

Note: The shortcoming of the optional methods is that it does not give room to know whether the row will appear above or below; likewise whether the column will appear left or right of the selected column

Practice 8

How to insert New Row to the Bottom of a Table

- Position the **insertion point** in the last cell of the table
- Press **Tab key** on the keyboard.

3.5 Deleting Table, Rows and Columns

Just as there is need to add rows or columns to a table, also there is need at times to delete rows or columns, even the entire table.

Delete **row 5** i.e. **Abdul Hassan** and **Column 3** i.e. **English** from your table

Practice 9

How to delete Rows, Column or Cells

- Select the **parts of the table** i.e. **row 5** and **Column 3** one after the other
- Click on the **Table menu** and locate **Delete**
- Choose either **Delete Rows** or **Delete Columns**.

Your table will now look like the one below:

NAMES	MATHEMATICS	GEOGRAPHY	MUSIC	AGRIC. SC.
Iredia Austine	54	48	39	53
Onome Ejiro	65	74	65	65
Peter Ajala	58	47	59	62
Bayo Tunde	45	65	68	70

Optional Method

- Highlight the **Row** or **Columns** you want to delete
- Right click on the **highlighted row** or **column**
- Click on **Delete Rows** or **Delete Columns**.

3.6 Text Orientation (Direction) and Alignments in a Table

At default, the orientation of text in a cell is horizontal and the alignment is top left in the cell. However, texts in a table could be directed vertically down or up in other to create space for more data entries in a table. Text could either be aligned to the top, center or bottom. Office 2000 and above provide nine options for alignment of text in a cell.

Practice 10

How to direct Text in Table

- Select the **cell(s)** – in this case, the **first row** that contains the field headings is selected.

- Activate the **format menu** and click on **Text Direction**
Text direction dialog box such as the one below will come up.

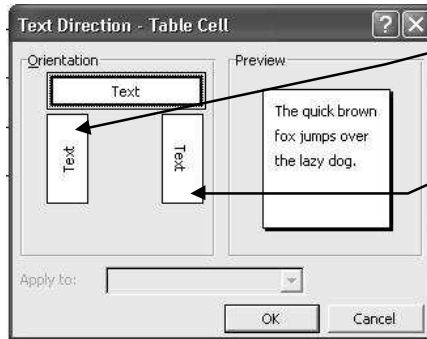

Click on **text vertical up** button to make the orientation vertically up

Click on **text vertical down** button to make the orientation vertically down

You will notice from the preview section how the orientation changes.

Click on OK to carry out your action.

For our case, **vertical up** is applied and the new table is shown below:

NAME S	MATHEMATICS	GEOGRAPHY	MUSIC	AGRIC. SC.
Iredia Austine	54	48	39	53
Onome Ejiro	65	74	65	65
Peter Ajala	58	47	59	62
Bayo Tunde	45	65	68	70

Practice 11

How to align Text in a Cell

To center aligned the Field Headings

- Select the **first row** that contains the **headings** as shown below:

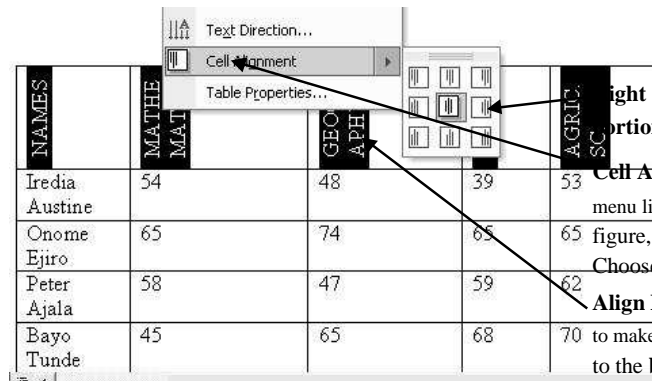

Click on any selected portion, then locate **Cell Alignment** to give you a menu like the one seen on the figure, Choose **Align Bottom Center** icon to make the headings aligned to the **bottom center**.

Practice 12

How to align text in Selected Cells

- Select **all the cells** that contain the data as shown below if you want the format to apply only to some of the inside text:

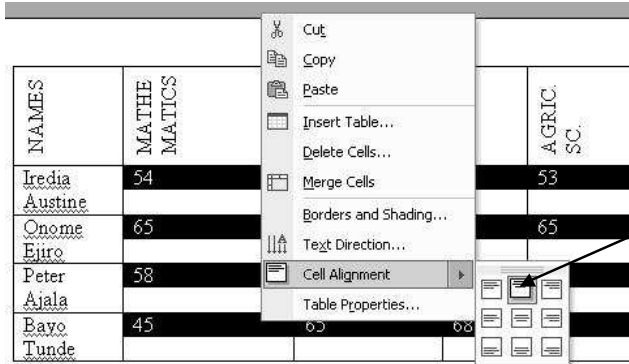

Right Click on any selected portion, locate **Cell Alignment**, Choose **Align Top Center** icon to make the text aligned to **top center**

Optional Method

- Reveal **tables and border tools bar** if it is hidden.

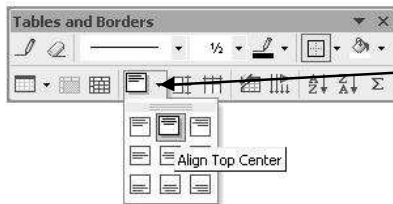

Click on the **down facing arrow** by Cell Alignment Icon, and then choose **Align Center Top** option or any other alignment of your choice.

NAMES	MATHE MATICS	GEOGR APHY	MUSIC	AGRIC. SC.
Iredia Austine	54	48	39	53
Onome Ejiro	65	74	65	65
Peter Ajala	58	47	59	62
Bayo Tunde	45	65	68	70

Table after applying the alignments.

3.7 Adjusting Row Height and Column Width

Table’s rows and columns are sometimes expanded or contrasted to accommodate texts in a particular cell if Autofit to content is not used to insert the table.

Practice 13**How to adjust Row Height and Column Width**

- Position the **mouse pointer in any of the cell** of the table

*You will notice that both the **vertical** and **horizontal rulers** have taken the dimensions of the table's row and columns.*

Click on **Move Table Column** then hold down the mouse button and drag to the right or left to enlarge or reduce the column width

Click on **Adjust Table Row** and then hold down the mouse button and drag up or down to enlarge or reduce the row height

NAMES	MATHEMATICS	GEOGRAPHY	MUSIC	AGRIC. SC.
Iredia Austine	54	48	39	53
Onome Ejiro	65	74	65	65
Peter Ajala	58	47	59	62
Bayo Tunde	45	65	68	70

Optional Method

- Move your **mouse pointer** to the **line border** between the rows or **columns** until the pointer changes to a **double cross arrow**.
- Click and hold down the mouse button and **drag up** or **down** to enlarge or reduce the **row height** or drag to the **right** or **left** to enlarge or reduce the **column width**

NAMES	MATHEMATICS	GEOGRAPHY	MUSIC	AGRIC. SC.
Iredia Austine	54	48	39	53
Onome Ejiro	65	74	65	65
Peter Ajala	58	47	59	62
Bayo Tunde	45	65	68	70

After the adjustments, you will notice that the table now looks smaller and all the data are now properly arranged.

3.8 Moving Table

A small table like the one above can be repositioned in any part of the document as you wish by dragging.

Practice 14

How to move Table

- Click on **select All button** then hold and drag to move the table

3.9 Sorting Table Data

Sorting table data is a way of arranging data in ascending or descending order for easy reference or retrieval of the data.

Practice 15

How to sort Table Data

- Position the **cursor in the first cell** i.e. NAMES of the table or **select the whole table**
- Activate the **table menu** and then click on **Sort** command

The sort dialog box such as the one below will come up

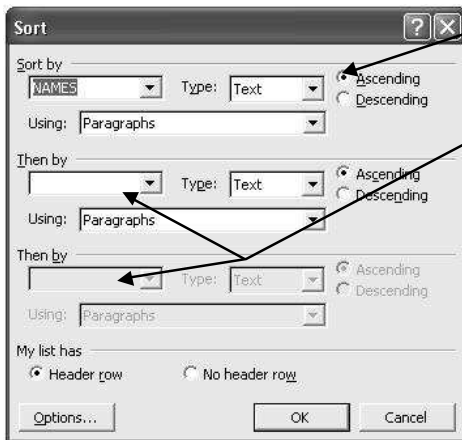

Select either **Ascending** or **Descending** (in this case, ascending is selected).

You can use the 2nd and 3rd **Sort by**, if you want to use another field heading to sort. This is often used when a database has field headings such as Surname, First Name and Middle Name. It is then good to use the 2nd and 3rd **Sort by** to arrange those names with the same surname or first name.

Click OK to carry out your action.

NAMES	MATHEMATICS	GEOGRAPHY	MUSIC	AGRIC. SC.
Bayo Tunde	45	65	68	70
Iredia Austine	54	48	39	53
Onome Ejiro	65	74	65	65
Peter Ajala	58	47	59	62

Table after the Sort ascending command was applied.

You have noticed that the first name now is Bayo Tunde. That is how they would be arranged notwithstanding how long the list may be; and all other data associated with them will follow suit.

3.10 Splitting Table Cells

Table cells are split in order to enter more data in continuation of the previous data, most often the field headings. *For example, let us include theory and objective column under Geography.*

Practice 16

How to split Cell(s)

- Erase the **data** under **Geography** and **type them again after splitting**.
- Insert a **row** immediately after the field headings' row, to enable you type Theory and Objective under Geography.

Select the **cells** you want to split as shown on the first diagram below:

- Activate the **table menu**, locate **Split cells** and click on it.

The split cells dialog box (2nd Fig) will come out.

NAMES	MATHEMATICS	GEOGRAPHY	MUSIC	AGRIC. SC.
Bayo Tunde	45		68	70
Iredia Austine	54		39	53
Onome Ejiro	65		65	65
Peter Ajala	58		59	62

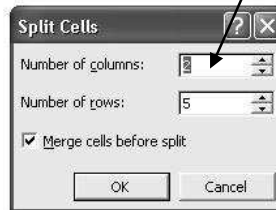

Type or scroll to enter the **number of columns**. In this case, 2 is entered.

Click **OK** or press **Enter Key** to carry out your action.

Note: Do not touch the number of rows

NAMES	MATHEMATICS	GEOGRAPHY		MUSIC	AGRIC. SC.
Bayo Tunde	45	Theory	Objective	68	70
Iredia Austine	54			39	53
Onome Ejiro	65			65	65
Peter Ajala	58			59	62

Table after splitting.

You can now enter the data for Geography - Theory and Objective

3.11 Table Borders

The vertical and horizontal lines form the borders in a table. You can beautify the table by applying different borders to the cell, row, column, or the whole table. Colour could also be applied if you are using colour printer.

Practice 17

How to format Table into Borders

- Select the **row(s)**, **column(s)** or **the whole table** (in this case, the whole table is selected).
- Activate the **Format menu**
- Click on **Border and Shading**

Border and Shading dialog box such as the one below will appear

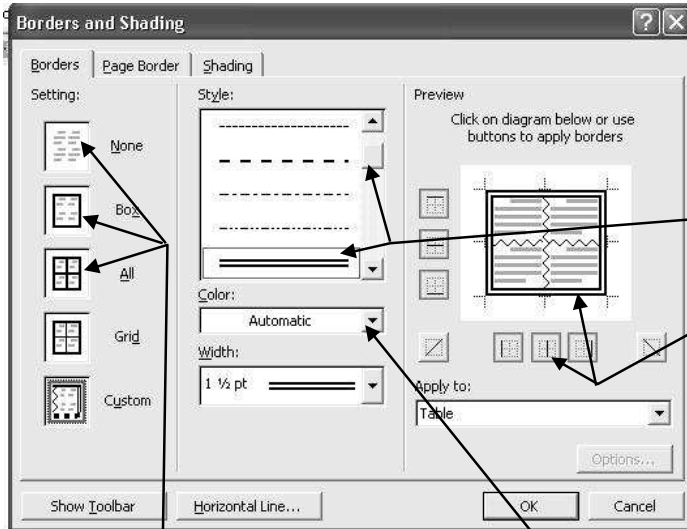

The middle lines either in the diagram or buttons represents all the vertical and horizontal lines inside the table.
 Scroll and click to select any **border style**
 Click on the **buttons** or **diagram** to apply the particular border style
 Here, wavy line is used for inside vertical and horizontal borders, and the outside borders are on double line i.e. both vertical and horizontal lines

The **None Box** and **All buttons** could be used to apply or remove borders

Click on the **down facing arrow** to apply colour if you are using colour printer

NAMES	MATHEMATICS	GEOGRAPHY		MUSIC	AGRIC. SC.
Bayo Tunde	45	Theory	Objective	68	70
Iredia Austine	54			39	53
Onome Ejiro	65			65	65
Peter Ajala	58			59	62

Table after applying different styles of borders

4.0 CONCLUSION

With table, some records for example, student's records could be entered haphazardly and later sort out in alphabetical (ascending) order.

5.0 SUMMARY

Table cells could be merged and split in order to provide additional information.

6.0 TUTOR-MARKED ASSIGNMENT

Insert 10 x 6 table to reveal information of 10 students in 6 subjects. Choose names and subjects as you like. Sort the names in ascending order.

7.0 REFERENCES/FURTHER READINGS

French, C.S. (2000). *Computer Science*, Asfifor Colour Press: Gosport Hants, 5th Edition.

Petroleum Training Institute (PTI), (1999). *Lecture Manual on Word Processing*, Warri.

UNIT 6 MICROSOFT WORD CONTINUED: MORE FORMATTING, EDITING AND PRINTING

CONTENTS

- 1.0 Introduction
- 2.0 Objectives
- 3.0 Main Content
 - 3.1 Borders and Shading
 - 3.2 Creating Documents in Word Pad
 - 3.3 Renaming a File or Folder
 - 3.4 Recycle Bin
 - 3.5 Printing
- 4.0 Conclusion
- 5.0 Summary
- 6.0 Tutor-Marked Assignment
- 7.0 References/Further Readings

1.0 INTRODUCTION

There are some document formats and edits that are not so related to the ones we learnt in unit 4, consequently, this unit will let us have knowledge of such formatting and editing of text and miscellaneous topics.

2.0 OBJECTIVES

At the end of this unit, you should be able to:

- apply colours shading colour to text in order to create distinctive emphasis
- apply page boarder to make the document look attractive
- create a file in word pad
- define Recycle Bin
- rename and delete file or folder
- print a document.

3.0 MAIN CONTENT

3.1 Borders and Shading

Borders and shading around selected paragraph or text make a document looks more presentable with distinctive emphasis. Art page border could

be used to add beauty to the front page of a document. Example of Art border is shown on the first page of this module.

Practice 1

How to add Shading to Selected Text

- Open **MS-Word Tutor** File and select only the third paragraph
- Activate the **Format** menu, click **Borders and Shading**

Borders and Shading dialog box like the one below will come out

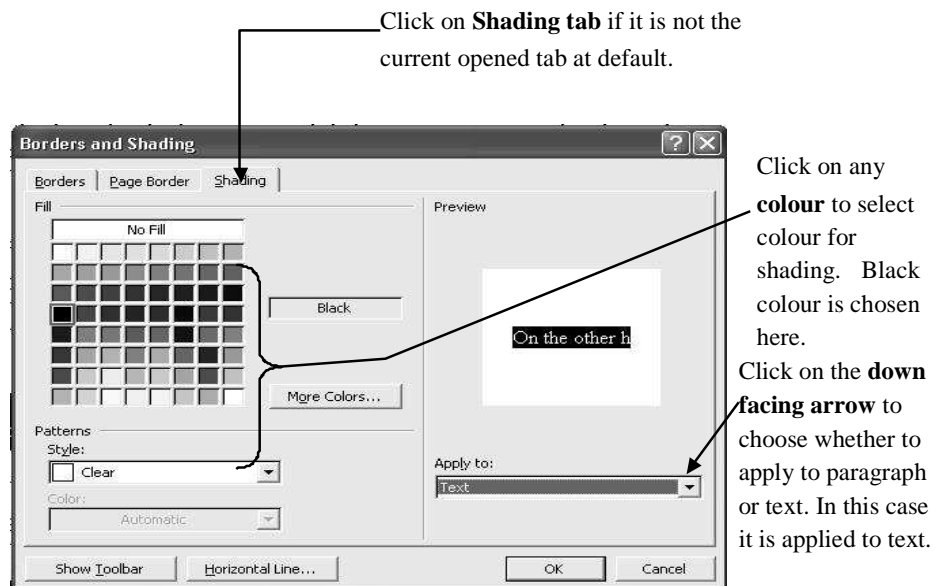

On the other hand, the tax collectors were so cruel to the extent that they will take away a child in place of his father if the situation permits. They

*Text after applying
Shading format*

Note: If the font colour and the shading colour are the same, change the font colour to the opposite colour of the shading colour. For instance the font colour above was changed to white to get the opposite of black.

Optional Method

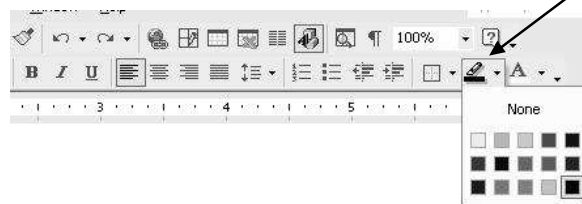

Click on the **down facing arrow** by the **Highlight Icon** on the **formatting tools bar**. Then click on any **colour** and release your finger from the mouse

Take the **mouse pointer** to the word and **double click** on it, or hold and drag across to highlight

Practice 2

How to add Border to a page

- Place the **cursor** at anywhere inside the document
- Activate the **Format menu**, click **Border and shading**

Borders and Shading dialog box like the one below will come out.

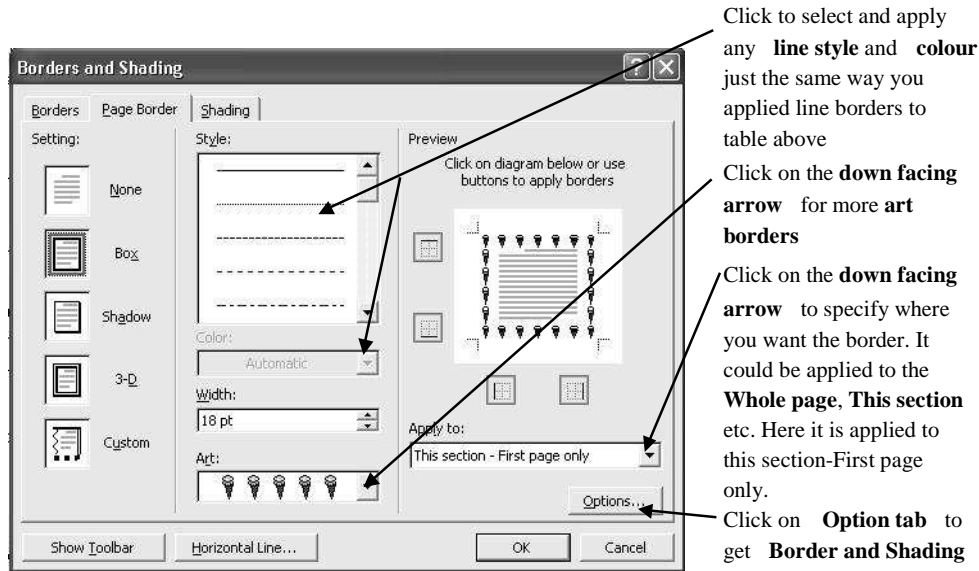

Click to select and apply any **line style** and **colour** just the same way you applied line borders to table above

Click on the **down facing arrow** for more **art borders**

Click on the **down facing arrow** to specify where you want the border. It could be applied to the **Whole page, This section** etc. Here it is applied to this section-First page only.

Click on **Option tab** to get **Border and Shading Options dialog box** such as the one below to specify how you want the border to appear

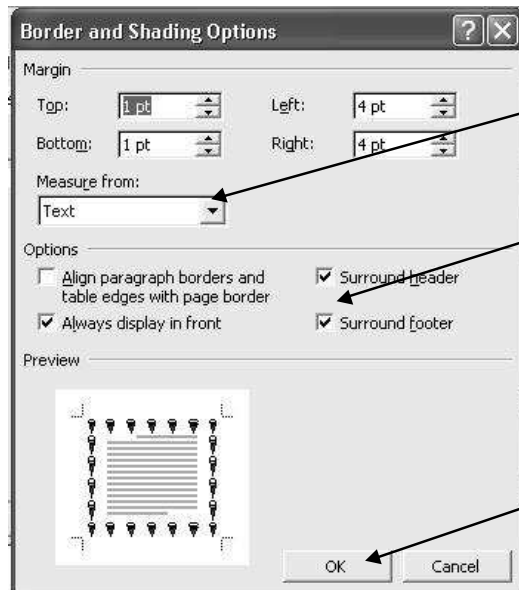

Click on the **down facing arrow** to select **Edge of Page** or **Text**. Note that if you select Edge of page option, the border will extend to include the margins.

Click to **uncheck Surround header** and **Surround footer options** if you do not want the border to surround header and footer. Here, they are not unchecked. That is why the border on the page of demonstration above, includes the Header – *MIS in Educ.*, and the Footer – **page number**.

Click on OK and the other OK on the cascaded **border shading dialog box** to carry out your action.

3.2 Creating Documents in Word Pad

We shall create another document (file) which we shall use to practice **rename** and **file deletion** in **WordPad** in order to prove to you that your knowledge of MS-Word Application has covered WordPad as I said at the beginning; you will notice that it is similar to MS-Word, but limited to some few commands.

Practice 3

How to create a Document in Word Pad

- Activate the **Start Button**
- Locate **Programs**
- Locate **Accessories**
- Click on **WordPad** to reveal the WordPad window such as the one below:

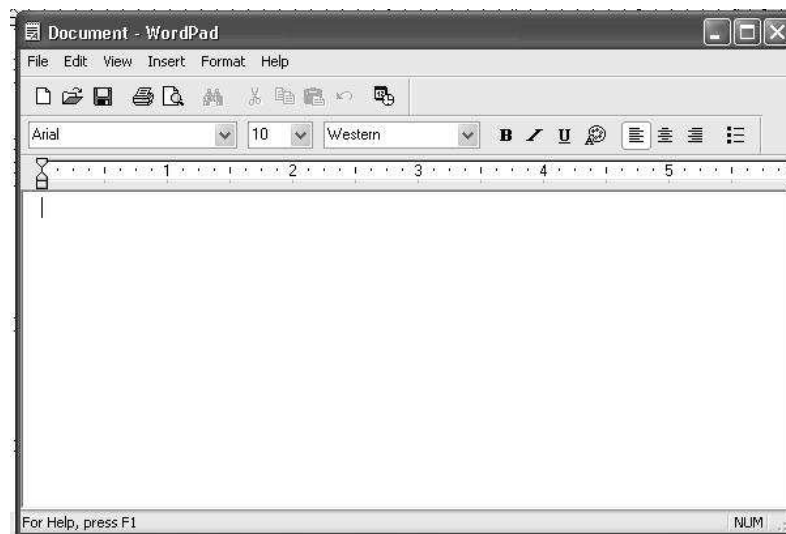

- Type the following few lines of text:

**Bright some days, good bye, good bye,
Everything passes away, away,
I have nobody to comfort my soul,
I 'd better paddle my own canoe, paddle my own canoe.**

- Save it with a name – **CANOE**, just as the same way you saved for the first time in MS-Word
- Close the **window(s)** so that you can be at your desktop

3.3 Renaming a File or Folder

Renaming is a process of labeling a file/folder with another name. It does not change the content of the file or folder, but can affect the location.

*Note: Remember that the ideal place to store your files / folders is **My Documents** folder. Therefore whenever you want to look for a file you created with any Application Programme, open My Documents Icon at the desktop or from any other place as you might discover by yourself.*

Practice 4

How to rename a File / Folder at the Desktop

- Open **My Document Icon** at the **Desktop** with any method known to you

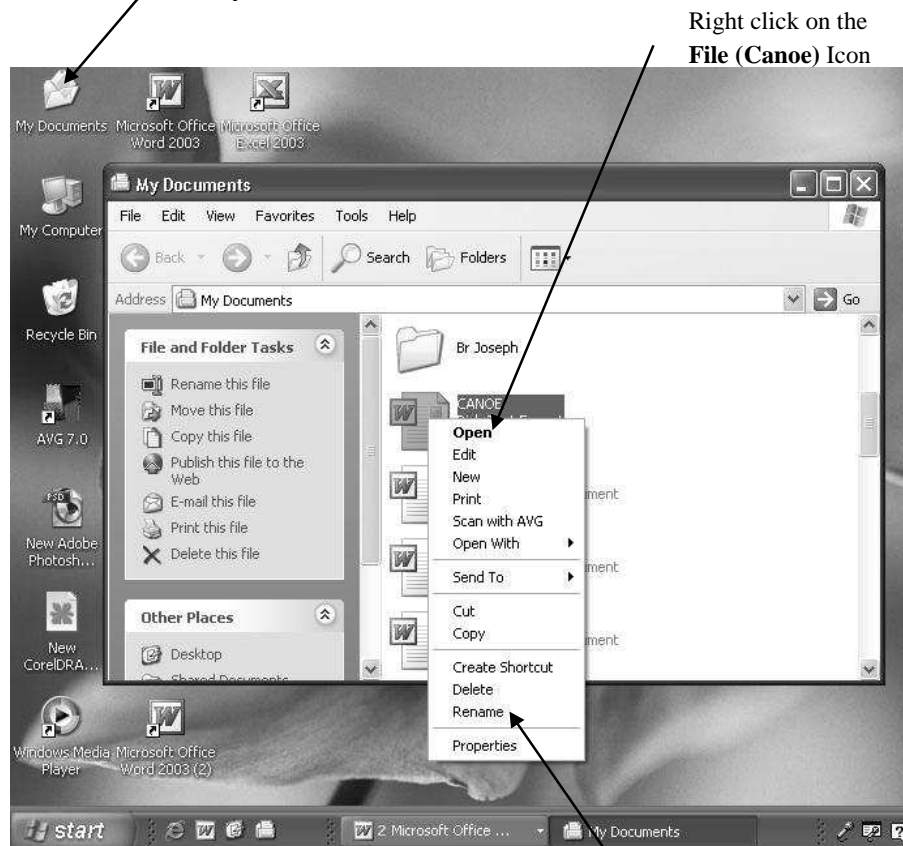

You will observe that the cursor is now flashing after the last character of the name of the file like the one demonstrated here:



- Type the **new name** e.g. **SHIP**
- **Press Enter Key** on the keyboard or click **empty space** outside the file

3.4 Recycle Bin

The file(s) you deleted are stored in the recycle bin. A recycle bin is a holding place for deleted files in windows environment. Deleted file(s) is/are not usually removed from your computer Hard disk until you empty the recycle bin. This implies that you can retrieve file(s) you deleted mistakenly, if you have not emptied your recycle bin. This also suggests that with the view to free up your disk space you must empty your recycle bin periodically.

***Note:** Any file deleted at the command prompt or from a floppy disk does not go to the recycle bin.*

Practice 5

How to erase (delete) an Unwanted File or Folder

Follow the same procedures of how to rename a file above i.e.

- Open **My Document Icon** at the **Desktop** with any method known to you
- Right click on the **File (Canoe) Icon**
- From the pop up menu, locate **Delete**, then click on it.

Confirm File Delete dialog box such as the one below will appear

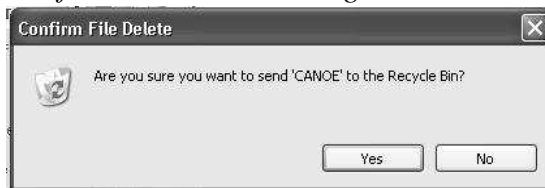

- Click **Yes** to confirm deletion from the recycle bin dialog box.

Optional Method

- Click to select the **Icon** or **file**
- Press **delete key** on the keyboard or choose **Delete** option from the file **menu** as the case may be
- Click **yes** to confirm deletion from the recycle bin dialog box

Practice 6

How to recall (restore) the Deleted File

- Open the recycle bin **icon** at the **desktop**
- Select the **file** you want to restore
- From the **file menu** click **restore**

Optional Method

- Open the recycle bin **icon** at the **desktop**
- **Right click** on the **file** then select **restore** command.

Practice 7

How to Empty the Recycle Bin

- Open the recycle **icon** at the **desktop**
- Activate the **file menu** and select **empty recycle bin**

Note: *Mind the way you use this command because it will remove everything in the recycle bin, and there is no way you can easily regain any of them.*

3.5 Printing

Print command allows you to print out the document on a paper. That is a way of producing the hard copy.

It is good that you preview the document to see how it will look like after printing. In computer jargon, it is called WYSIWYG (What You See Is What You Get).

It is not all the commands in the print dialog box that are used to set your printing.

Practice 8

How to preview a Document before the actual Printing

- Open the **document (MS-Word Tutor)** and click to ensure that the **cursor** is inside the document.
- Activate the **File menu** and click on **Print Preview** or click on

Print Preview icon  on the **Standard tools bar**

The Print Preview window such as the one below will open

Click on the **Magnifier icon** to zoom so as to see details of the preview page

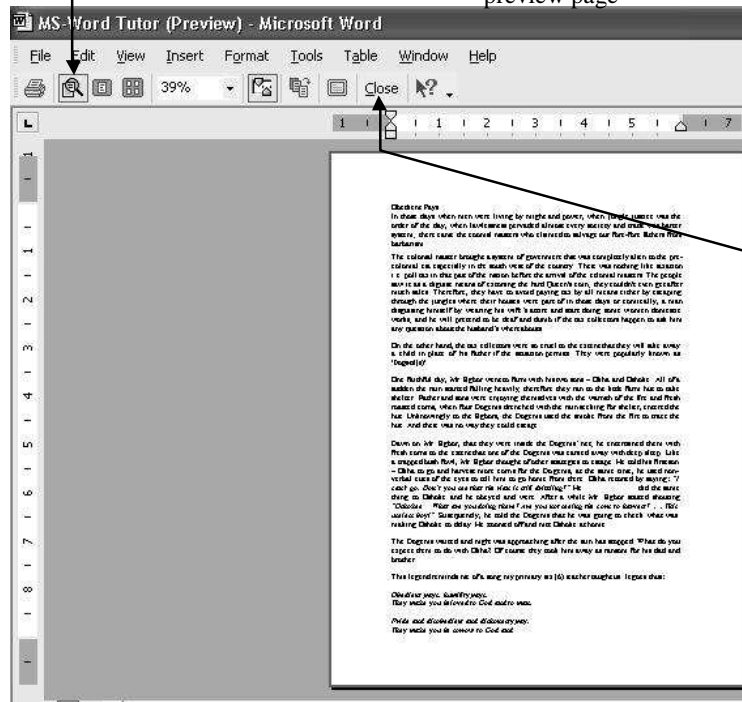

Click on this **close button** or the close button at the top extreme end of the window in order to return to the real document window when you are through with the preview.

Practice 9

How to print a Document

- Open the **document** e.g. (**MS-Word Tutor**) and click to ensure that the cursor is inside the document.
- Activate the **File menu** and click on **Print** or press **Ctrl + P** on

the keyboard. Please do not use the **Print icon**  on the **Standard tools bar** at first printing because it will not give you the print dialog box for printing set-up.

The Print dialog box like the one below will appear

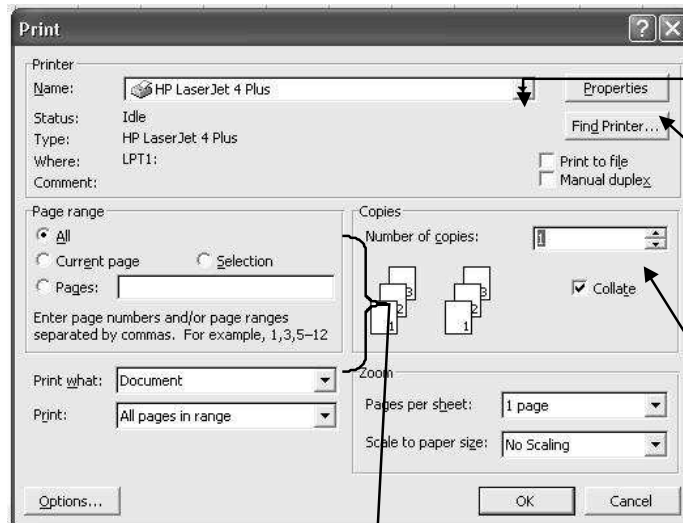

Click on the **down facing arrow** to select printer, if you have more than one printer installed

Click on **Properties** to select orientation under **Layout** i.e. Portrait or Landscape. The **Paper size** is also selected through this medium if it is on **automatically select**

Type or scroll to enter the **number of copies** you want a page to produce.

In **Page range section**, select **All** - for all the pages to be printed; **Current Page** - for the page where the cursor is to be printed out; **Selection** - to print any selected part; **Pages** if you want to type the particular page number(s) you want to print.

4.0 CONCLUSION

Any deleted file from the hard disk goes to the Recycle Bin, whereas files that are deleted from any removable disk such as diskette, flash disk do not go to the Recycle Bin

5.0 SUMMARY

It is good to print the preview of any document before actual printing to see how the print out (hard copy) will look like.

6.0 TUTOR-MARKED ASSIGNMENT

1. Define the term Recycle Bin
2. Explain the procedure you can use to rename a file in My Document's folder.

7.0 REFERENCES/FURTHER READINGS

French, C.S. (2000). *Computer Science*, Asfifor Colour Press: Gosport Hants, 5th Edition.

Petroleum Training Institute (PTI), (1999). *Lecture Manual on Word Processing*, Warri.

MODULE 3

Unit 1	IT and MIS in Education
Unit 2	Computer Spreadsheet Management Using MS-Excel MS-Excel Continued: Formatting and Editing of Worksheet Data
Unit 3	MS-Excel Continued: More Formatting and Editing of Worksheet Data
Unit 4	Microsoft Excel Continued: Database
Unit 5	Microsoft Excel Continued: Charts

UNIT 1 IT AND MIS IN EDUCATION
COMPUTER SPREADSHEET MANAGEMENT
USING MS-EXCEL

EXCEL WELCOME SCREEN AND FEATURES**CONTENTS**

1.0	Introduction
2.0	Objectives
3.0	Main Content
3.1	What is Spreadsheet Management?
3.2	What is Microsoft Excel (MS-Excel)?
3.3	Means of Navigation within a Worksheet
3.4	Entering Worksheet Data to Create a Document
3.5	Saving, Closing and Opening Books (Documents)
3.6	Editing the Content of a Cell
3.7	Columns' Widths and Rows' Heights
3.8	Selection or Highlightment
3.9	Clearing and Deleting Cells, Rows and Columns
4.0	Conclusion
5.0	Summary
6.0	Tutor-Marked Assignment
7.0	References/Further Readings

1.0 INTRODUCTION

Spreadsheet contains a grid of rows arranged in numbers (1 2 3 etc) and columns arranged in letters (A B C etc). The most common application programme under Spreadsheet is Microsoft Excel (MS-Excel). Since it is a window based application, particularly among the office of windows operating system, it shares some similarities with other application programmes especially MS-Word. Therefore, in areas where such similarities are obvious, mere mention will be made without detailed explanation or illustration.

2.0 OBJECTIVES

At the end of this unit, you should be able to:

- define what is spread sheet management and the definition of MS –Excel
- load Excel and recognize the Welcome screen environment and features
- define columns, rows, work book, worksheet cells and range of cells
- enter worksheet data to create a document
- edit the content of a cell
- adjust columns' width and rows' height
- select various parts of a worksheet such as columns, rows, cells, range etc.
- delete columns and rows
- Insert rows and columns and worksheet.

3.0 MAIN CONTENT

3.1 What is Spreadsheet Management?

It is application software that contains table of cells arranged in the matrix of rows and columns. The most evident power of spreadsheet is its ability to handle calculations very fast. Examples of spreadsheet software are Quarto pro, Lotus123, Microsoft Excel, Supper Calc, Supper project, K- Speed, Plan Perfect etc; and out of these, we shall use MS-Excel as our application.

3.2 What is Microsoft Excel (MS-Excel)?

Microsoft excel is a spreadsheet management software for calculating, organizing, analyzing, and presenting data in various forms. Among others, it is meant for business management, financial management, scientific and statistical use of specialized functions and graphs.

There is a worksheet to manipulate and analyze data such as numbers, text, and formula. With chart, you can quickly present your worksheet data graphically using either two-dimensional (2-D) or three-dimensional (3-D) chart types. While databases facilities make it easy to conveniently sort, search, and manage a large amount of information on a worksheet, using standard database operations.

Indeed, Microsoft Excel is very important in information management in education because it helps to generate and analyze data in a special way to give useful information.

Practice 1

How to Load Ms-Excel

- Cold boot the computer and after it has finished booting successfully and when it is at the desktop, then,
- Activate the **Start button** to bring out the **start menu**
- Locate **Programmes (All Programmes in Office XP)** and click on **MS-Excel**

Optional Method:

- Open the **MS-Excel Shortcut Icon**  on the desktop or on the **Taskbar** , if it is created

After clicking on Excel using any method above, the **welcome screen** such as the one bellow will come out.

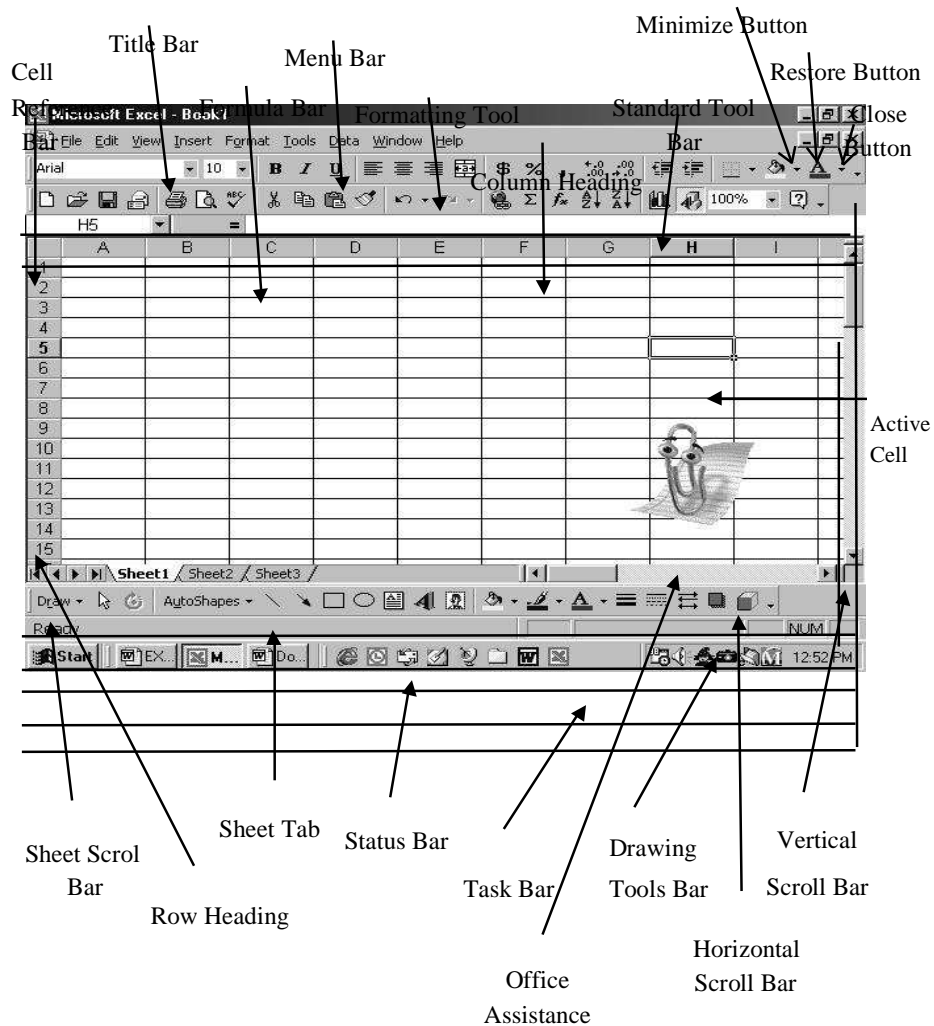

Excel Welcome Screen

The tools bars that you will work with in Excel are similar to the ones in Ms-Word. Therefore, only those that are peculiar to Excel alone are given vivid explanation here.



Reference Bar and Formula Bar

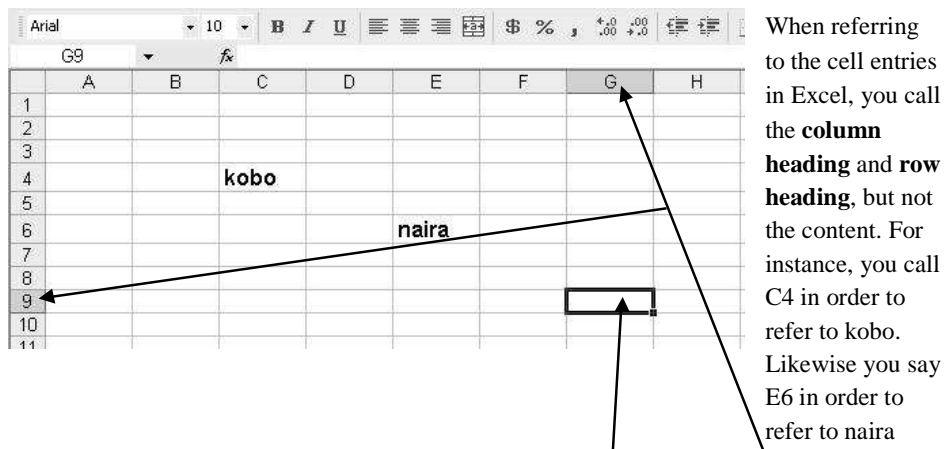

The Reference bar and formula bar are joined together. It is the bar below the standard or formatting tool bar as the case may be.

The Reference bar displays the active cell where the cursor is e.g. G9 in the reference bar above and below. It is also called **Name Box**.



The **column heading (G)** and **row heading (9)** of the **active cell** are **highlighted** with blue or dark colour.

Note: The **column headings** can take any case i.e. upper or lower case. For example, **A8**, **T5** and **P12** or **a8**, **t5** and **p12**.

The formula bar at times displays some icons such as **cancel** , **enter** , **sign of equality =** or **function sign** , depending on the task the user is doing.

The **enter icon** serves the same purpose of **enter key** on the keyboard. Also, **cancel icon** performs the same function of **Esc key** or **Del key** on the keyboard. The moment you start typing or editing cell data, the formula bar becomes active.

Mouse Pointer

This shows where the next action will occur when you click the mouse. It takes the shape of an **I-beam** when it is in the formula bar or cell that



is edited. It is a **cell pointer**  when placed over a cell; and an **arrow** when you point at graphics, status bar, menu bar, scroll bar etc.

Columns/Rows Headings

In Excel, the columns are arranged in alphabetical order i.e. A-IV and the rows are in numerical order i.e. 1-65536. At times they may set the columns headings on numerical number same as the rows headings as you can see from the figure below; and this may confuse you when referring to cell entries. If yours is like that, you can change it as follows:

Practice 2

How to set the Column Headings to take Numerical or Alphabetical Value

- Activate the **Tools** menu and click on **Option** command from the pop-up menu

The Option dialog box such as the one below will show

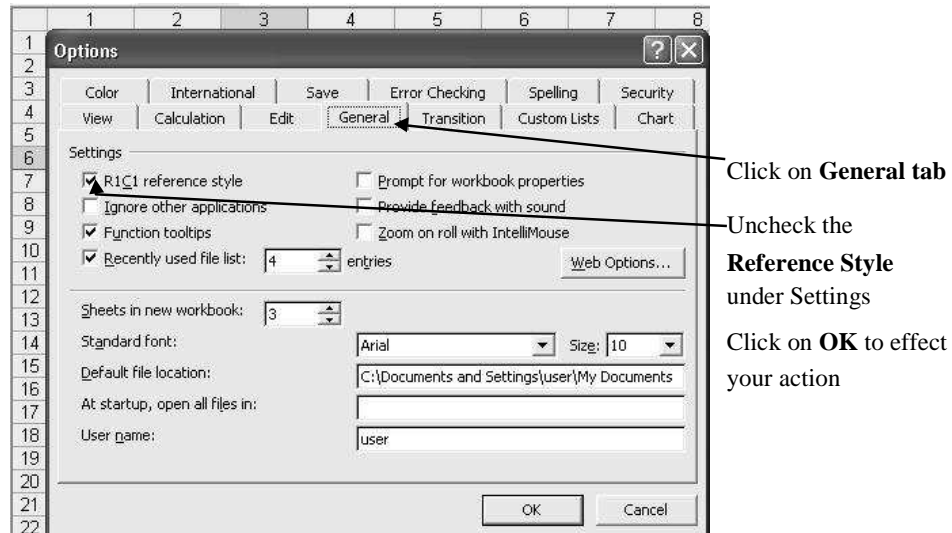

Practice 3

How to view the last Column/Row

-  Hold down the **Control (Ctrl)** key and tap the **Right Arrow** key in order to see the **last column**

-  Hold down the **Control (Ctrl) key** and tap the **Down Arrow key** in order to see the **last row**

Workbook: A workbook is a collection of worksheet in Microsoft Excel; it is the file in which you work and store your data. Because each workbook can contain many sheets, you can organize various kind of related information in a single file.

Worksheet: Is the primary document for the storage and manipulation of data; it is always a part of the workbook. Worksheet is for listing and analyzing data. You can enter and edit data on several worksheets simultaneously and perform calculation based on data from multiple worksheets.

Usually, it holds texts, figures graphs etc. Each worksheet is a rectangular grid of **265 columns** and **65,536 rows** which form the cells. Once excel is loaded or invoked, a worksheet will be presented to you to work with.

Cell: A cell is an intercept of rows and columns (i.e. where a row and a column meet). Hence the entire worksheet is a grid of cells. A cell can contain word, numeric values, symbols, formula or nothing. Each cell is identified by a cell address format known as **Column - Row** format e.g. A1, C3, E4, or **Row - Column** format. The content of a cell is identified with its address

Range: A range is a rectangular box that comprises numbers of cells. It is identified or noted with the first cell address separated with colon and the last cell address e.g. A1:D8 In other words, it is a reference that relates to more than one cell. Most often in order to perform some specific task you may need to define or specify a range to be used.

The method of referring to a range is by calling the first cell and then the last cell. For example, in the figure below the numbers occupy cell B4, C4, D4, E4, F4, G4 and H4. Since it is a range, just take the first cell and the last cell and separate them with a colon (:) Examples are shown below:

	A	B	C	D	E	F	G	H	I
1									
2									
3									
4		42	36	56	54	28	95	27	
5									
6									
7									

B4:H4

	AG	AH	AI	AJ	AK	AL
1						
2						
3						
4						
5		45	22	45		
6		47	78	47		
7		84	54	36		
8		14	68	78		
9		65	47	5		
10		49	77	56		
11						

AH5:AJ10

	O	P	Q	R	S
1					
2				45	
3				25	
4				65	
5				89	
6				47	
7				25	
8				36	
9				47	
10					

r2:r9

3.3 Means of Navigation within a Worksheet

To move cursor from one cell to another use the

arrow keys



to move the cursor to the desired cell.

Or

Simply place the **mouse pointer** in the cell you wish to move to and then **click**. Also **Enter key** and **Tab key** could be used to move the cursor down or left and right.

3.4 Entering Worksheet Data to create a Document

You can enter **constant values** and **formulae** into a worksheet. A constant value is a data that is typed directly into a cell without attaching any cell reference name to it. It can be a numeric value; letters, date, time etc.

On the other hand, a formula is a sequence set of instruction coded for calculation. It is made up of constant values, cell references names, functions or operators that produce new values from existing value. More of formulas will be seen later.

Let us start by creating a small database to practise how to enter data into a worksheet. Please type exactly the way it is. We shall use it for our practical exercises in Excel

In excel, **page setup** is not necessary at the beginning; you might set up the page by the time you are about to print.

Practice 4**How to enter Data into a Worksheet**

- **Click on any cell** you want to enter the data into – in this case, **cell A1** to type **surname**. Then use any of the navigators to move to the next cell you want to type in.

Note that the cursor will not blink until after you have started typing unlike MS-Word. Please do not jump any cell even though the entry in the preceding cell spreads across the one you want to type in, ignore it and continue your typing.

	A	B	C	D	E	F	G	H
1	SURNAME	FIRST NAME	MIDDLE NAME	ENG. LANG	MATHEMATICS	SOCIAL SCIENCES	HOME ECONOMICS	
2	OJEYEMI	BIOLA	FAITH	45	58	92	35	
3	ADADU	PIUS	JAMES	39	58	24	46	
4	OKAFOR	VIVIAN	ADA	54	84	57	57	
5	JACKSON	TITILAYO	SAMUEL	62	43	58	75	
6	IYERE	JOHN	SOLOMON	48	49	47	57	
7	OKAFOR	FRANK		47	45	76	47	
8	BELLO	SARAH	BIOLA	81	67	48	47	
9	TOPE	OMLARA	MUYIBAT	47	38	54	12	
10	YAHAYA	SULE	MAKAMA	47	59	47	45	
11	TOCHUKWU	EZE		45	47	23	25	
12	EGIEGBA	PAUL	UDO	49	78	45	46	
13	OKAFOR	CHIAMAKA	CECELIA	54	58	35	24	
14	ADEBAYO	AARON	ANDREW	28	49	72	28	
15	MENSA	AMENKWE		48	65	58	24	
16	ASHIRU	DAHATU	ISAH	46	46	56	57	
17	NJOKU	CALISTA	EBERE	47	78	58	87	
18	RASAQ	TITILOPE		45	58	49	54	
19	PETER	BASSEY	EDIDIONG	82	59	75	56	
20	OKAFOR	BENJAMIN	EMEKA	57	57	54	47	
21								
22								

3.5 Saving, Closing and Opening Books (Documents)

In every windows application programme particularly these ones – MS-Word, MS-Excel, MS-PowerPoint and MS-Access) that come with the Office; the procedures of saving, closing and opening files are the same. Therefore refer to MS-Word for the explanations

*Just as we did in MS-Word, we shall use a common name to save it for the first time for easy reference. The name you must use is: **Excel***

Tutor.

3.6 Editing the Content of a Cell

MS-Excel is not like MS-Word where you can easily edit text after typing. Any attempt to edit cell entry without bringing out the cursor first, will delete the entry. However, cell entries could be edited through the formula bar for convenience sake.

Practice 5

How to edit cell entries

For example the content of cell B9 is not correct. The content supposes to be OMOLARA. Letter O is missing. In order to add the missing letter, follow the methods below:

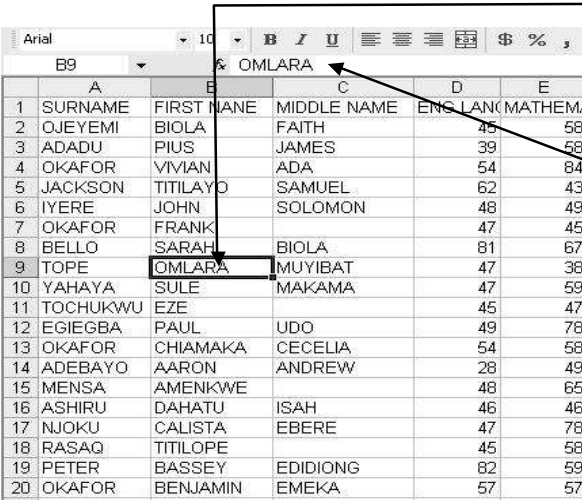

	A	B	C	D	E
1	SURNAME	FIRST NAME	MIDDLE NAME	ENG. LANG.	MATHEMATICS
2	OJEYEMI	BIOLA	FAITH	45	58
3	ADADU	PIUS	JAMES	39	58
4	OKAFOR	VIVIAN	ADA	54	84
5	JACKSON	TITILAYO	SAMUEL	62	43
6	IYERE	JOHN	SOLOMON	48	49
7	OKAFOR	FRANK		47	45
8	BELLO	SARAH	BIOLA	81	67
9	TOPE	OMLARA	MUYIBAT	47	38
10	YAHAYA	SULE	MAKAMA	47	59
11	TOCHUKWU	EZE		45	47
12	EGIEGBA	PAUL	UDO	49	78
13	OKAFOR	CHIAMAKA	CECELIA	54	58
14	ADEBAYO	AARON	ANDREW	28	49
15	MENSA	AMENKWE		48	65
16	ASHIRU	DAHATU	ISAH	46	46
17	NJOKU	CALISTA	EBERE	47	78
18	RASAQ	TITILOPE		45	58
19	PETER	BASSEY	EDIDIONG	82	59
20	OKAFOR	BENJAMIN	EMEKA	57	57

Click on the **particular cell** you want to edit (**B10** in this case that contains **OMLARA**). It will appear on the formula bar immediately you click

Move the **mouse pointer** to the **formula bar** and when it takes **I-Beam shape**, click to edit the entry

Optional Method

After clicking on the cell, press **F2 key** on the keyboard or **double click the mouse** to bring out the cursor for editing

Note: If you want to type a new entry to replace an existing one, just click on the cell and start typing. No need for you to look for cursor or go to formula bar for editing.

3.7 Columns' Widths and Rows' Heights

Worksheet Column Widths and Row Heights can be adjusted to fit the content of the cell in a similar way of adjusting table Column Widths and Row Heights in MS-Word. You can observe from the Field headings above that some of the field headings are not fully displayed e.g. ENG. LANGUAGE, MATHEMATICS, and SOCIAL STUDIES etc.

Although there are several methods of adjusting Column Widths and Row Height, but we shall restrict ourselves to the simplest method

Practice 6

How to adjust Column Width and Row Height

	A	B	C	D	E	F
1	SURNAME	FIRST NAME	MIDDLE NAME	ENG. LANG.	MATHEMA	SOCIA
2	OJEYEMI	BIOLA	FAITH	45	58	
3	ADADU	PIUS	JAMES	39	58	
4	OKAFOR	VIVIAN	ADA	54	84	
5	JACKSON	TITILAYO	SAMUEL	62	43	
6	IYERE	JOHN	SOLOMON	48	49	
7	OKAFOR	FRANK		47	45	
8	BELLO	SARAH	BIOLA	81	67	
9	TOPE	OMLARA	MUYIBAT	47	38	
10	YAHAYA	SULE	MAKAMA	47	59	
11	TOCHUKWU	EZE		45	47	
12	EGIEGBA	PAUL	UDO	49	78	

Move the **mouse pointer** to the **border line** between the **Row headings** (between 3 and 4 as in the figure in order to enlarge or reduce row 3 **and when it changes to this cross shape, then click, hold and drag** either up in order to decrease or drag down in order to increase the number of **inches** or **pixels** of the row.

Move the **mouse pointer** to the **border line** between the **Column headings** (between **D** and **E** as in the figure in order to enlarge or reduce column D i.e. Eng. Language field heading), **and when it changes to this cross shape, then click, hold and drag** either to the right in order to increase or drag to the left in order to decrease the number of **inches** or **pixels** of the column.

Note: The number of inches or pixels of the particular column or row will appear as you are dragging.

3.8 Selection or Highlightment

Before carrying out most commands and task in Microsoft excel, you must first select or highlight the part of the worksheet you want to work with. A worksheet selection could be a single cell, worksheet, a range of cells etc.

The absence of colour from the first cell in a range of cell does not mean that it is not selected.

Note: You will notice a dark or bluish colour on any selected part of a worksheet.

Practice 7

How to select the Whole Worksheet

Click on the **Select All Button** in order to select the **Whole Worksheet**. The **Select All Button** is the empty cell the arrow is pointing at i.e. the cell by the left of **A** and above **1**

	A	B	C	D	E	F
1	SURNAME	FIRST NAME	MIDDLE NAME	ENG. LANG.	MATHEMA	SOCIAL S
2	OJEYEMI	BIOLA	FAITH	45	58	92
3	ADADU	PIUS	JAMES	39	58	24
4	OKAFOR	VIVIAN	ADA	54	84	57
5	JACKSON	TITILAYO	SAMUEL	62	43	58
6	IYERE	JOHN	SOLOMON	48	49	47
7	OKAFOR	FRANK		47	45	76
8	BELLO	SARAH	BIOLA	81	67	48
9	TOPE	OMLARA	MUYIBAT	47	38	54
10	YAHAYA	SULE	MAKAMA	47	59	47
11	TOCHUKWU	EZE		45	47	23
12	EGIEGBA	PAUL	UDO	49	78	45
13	OKAFOR	CHIAMA	CECELIA	54	58	35
14	ADEBAYO	AARON	ANDREW	28	49	72
15	MENSA	AMENKWE		48	65	58

How to deselect or erase any Selection

Click any part of the worksheet or press **any arrow** key on the keyboard.

How to select a Single Cell

- Click on the **cell** you want to select and that makes the particular cell the active cell (a cell that is currently selected). And the address is always found on the cell reference bar.

Practice 8

How to Select Entire Row

	A	B	C	D	E
1	SURNAME	FIRST NAME	MIDDLE NAME	ENG. LANG	MATHEMATICS
2	OJEYEMI	BIOLA	FAITH	45	58
3	ADADU	PIUS	JAMES	39	58
4	OKAFOR	VIVIAN	ADA	54	84
5	JACKSON	TITILAYO	SAMUEL	62	43
6	IYERE	JOHN	SOLOMON	48	49
7	OKAFOR	FRANK		47	45

Click on the **row heading** i.e. **1,2,3** etc. In this case, **Row 4** is selected by clicking on **4** which is the row heading

	A	B	C	D	E
1	SURNAME	FIRST NAME	MIDDLE NAME	ENG. LANG	MATHEMATICS
2	OJEYEMI	BIOLA	FAITH	45	58
3	ADADU	PIUS	JAMES	39	58
4	OKAFOR	VIVIAN	ADA	54	84
5	JACKSON	TITILAYO	SAMUEL	62	43
6	IYERE	JOHN	SOLOMON	48	49
7	OKAFOR	FRANK		47	45
8	BELLO	SARAH	BIOLA	81	67
9	TOPE	OMLARA	MUYIBAT	47	38
10	YAHAYA	SULE	MAKAMA	47	59
11	TOPE	OMLARA	MUYIBAT	47	38

In case you want to select more than **one row** after you have selected the **first row**, hold down the **shift key**, and then **drag through the other adjacent rows**. For example, after selecting **row 4**, hold down the **shift key**, and then drag through **8**. Vice versa

Practice 9

How to Select Entire Column

	A	B	C	D	E
1	SURNAME	FIRST NAME	MIDDLE NAME	ENG. LANG	MATHEMATICS
2	OJEYEMI	BIOLA	FAITH	45	58
3	ADADU	PIUS	JAMES	39	58
4	OKAFOR	VIVIAN	ADA	54	84
5	JACKSON	TITILAYO	SAMUEL	62	43
6	IYERE	JOHN	SOLOMON	48	49
7	OKAFOR	FRANK		47	45
8	BELLO	SARAH	BIOLA	81	67
9	TOPE	OMLARA	MUYIBAT	47	38

Click on the **column heading** i.e. **A, B, C** etc. In this case, **column D** is selected by clicking on **D** which is the **column heading**.

	A	B	C	D	E
1	SURNAME	FIRST NAME	MIDDLE NAME	ENG. LANG	MATHEM
2	OJEYEMI	BIOLA	FAITH	45	58
3	ADADU	PIUS	JAMES	39	58
4	OKAFOR	VIVIAN	ADA	54	84
5	JACKSON	TITILAYO	SAMUEL	62	43
6	IYERE	JOHN	SOLOMON	48	49
7	OKAFOR	FRANK		47	45
8	BELLO	SARAH	BIOLA	81	67
9	TOPE	OMLARA	MUYIBAT	47	38
10	YAHAYA	SULE	MAKAMA	47	59
11	TOCHUKWU	EZE		45	47

In case you want to select more than **one column** after you have selected the **first one**, hold down the **shift key**, and then drag through the other adjacent **columns**. For example, after selecting **column D**, hold down the shift key, and then drag through **B**. Vice versa.

Practice 10

How to select a Range of Cells

	A	B	C	D	E
1	SURNAME	FIRST NAME	MIDDLE NAME	ENG. LANG	MATHEM
2	OJEYEMI	BIOLA	FAITH	45	58
3	ADADU	PIUS	JAMES	39	58
4	OKAFOR	VIVIAN	ADA	54	84
5	JACKSON	TITILAYO	SAMUEL	62	43
6	IYERE	JOHN	SOLOMON	48	49
7	OKAFOR	FRANK		47	45
8	BELLO	SARAH	BIOLA	81	67
9	TOPE	OMLARA	MUYIBAT	47	38
10	YAHAYA	SULE	MAKAMA	47	59
11	TOCHUKWU	EZE		45	47

Click on the **first cell**. In this case, **A2** is the first cell.

Hold down the **mouse button** and **drag through the other cells** until you get to the **last cell**; in this case, **D8**.

3.9 Clearing and Deleting Cells, Rows and Columns

Clearing and deleting are two ways of removing data from the worksheet. Clearing a cell includes clearing the contents, formats, notes etc assigned to that cell, but leaves the cleared cell, row or column in the structure of the worksheet. **Delete key** on the keyboard, also performs same function with the clear command in the edit menu. On the other hand, **Delete command** in the **Edit menu** or **Shortcut menu**, completely removes the cell, column, row from the position including the content and any format assigned to it.

Practice 11

How to clear Cell Contents, Formats, and Notes

- Load the document – **Excel Tutor**

	A	B	C	D	E	F
1	SURNAME	FIRST NAME	MIDDLE NAME	ENG. LANG	MATHEM	SC
2	OJEYEMI	BIOLA	FAITH	45	58	
3	ADADU	PIUS		39	58	
4	OKAFOR	VIVIAN		54	84	
5	JACKSON	TITILAYO		62	43	
6	IYERE	JOHN		48	49	
7	OKAFOR	FRANK		47	45	
8	BELLO	SARAH		81	67	
9	TOPE	OMLARA		47	38	
10	YAHAYA	SULE		47	59	
11	TOCHUKWU	EZE		45	47	
12	EGIEGBA	PAUL		49	78	
13	OKAFOR	CHIAMAKA		54	58	
14	ADEBAYO	AARON		28	49	
15	MENSA	AMENKWE		48	65	
16	ASHIRU	DAHATU		46	46	
17	NJOKU	CALISTA		47	78	
18	RASAQ	TITILOPE		45	58	

Right click on the column, row heading or cell. In this case, B i.e. column heading is used as an example.

From the pop-up menu, locate clear contents and click on it.

Alternatively, select column B and then press delete key on the keyboard

The result of the database after clearing the contents is shown below:

	A	B	C	D	E	F	G
1	SURNAME		MIDDLE NAME	ENG. LANG	MATHEM	SOCIAL S	HOME EC
2	OJEYEMI		FAITH	45	58	92	35
3	ADADU		JAMES	39	58	24	46
4	OKAFOR		ADA	54	84	57	57
5	JACKSON		SAMUEL	62	43	58	75
6	IYERE		SOLOMON	48	49	47	57
7	OKAFOR			47	45	76	47
8	BELLO		BIOLA	81	67	48	47
9	TOPE		MUYIBAT	47	38	54	12
10	YAHAYA		MAKAMA	47	59	47	45
11	TOCHUKWU			45	47	23	25
12	EGIEGBA		UDO	49	78	45	46
13	OKAFOR		CECELIA	54	58	35	24
14	ADEBAYO		ANDREW	28	49	72	28
15	MENSA			48	65	58	24

You will notice that the contents in all the selected cells are deleted but the column still remains intact. Please remember to click the undo icon  on the standard tools bar or press Ctrl + Z to bring back the contents.

Practice 12

How to Delete Cell, Columns and Row

- Load the document – Excel-Tutor

	A	B	C	D	E
1	SURNAME	FIRST NAME	MIDDLE NAME	ENG. LANG	MATHEM
2	OJEYEMI	BIOLA	FAITH	45	58
3	ADADU	PIUS	JAMES	39	58
4	OKAFOR	VIVIAN	ADA	54	84
5	JACKSON	TITILAYO	SAMUEL	62	43
6	IYERE	JOHN	SOLOMON	48	49
7	OKAFOR	FRANK		47	45
8	BELLO	SARAH	BIOLA	81	67
9	TOPE	OMLARA	MUYIBAT	47	38
10	YAHAYA	SULE	MAKAMA	47	59
11	TOCHUKWU	EZE		45	47
12	EGIEGBA	PAUL	UDO	49	78
13	OKAFOR	CHIAMAKA	CECELIA	54	58
14	ADEBAYO	AARON	ANDREW	28	49
15	MENSA	AMENKWE		48	65
16	ASHIRU	DAHATU	ISAH	46	46
17	NJOKU	CALISTA	EBERE	47	78
18	RASAQ	TITILOPE		45	58

Right click on the column, row heading or cell. In this case, 4 i.e. row heading is used as an example.

From the pop-up menu, locate Delete and click on it.

Optional Method

Select row 4

Activate the Edit menu and then click on Delete command from the pop-up menu.

The result of the database after clearing the contents is shown below:

EDUCATION

	A	B	C	D	E
1	SURNAME	FIRST NAME	MIDDLE NAME	ENG.LANG	MATHEMATICS
2	OJEYEMI	BIOLA	FAITH		
3	ADADU	PIUS	JAMES		
4	OKAFOR	VIVIAN	ADA		
5	JACKSON	TITILAYO	SAMUEL		
6	IYERE	JOHN	SOLOMON		
7	OKAFOR	FRANK			
8	BELLO	SARAH	BIOLA		
9	TOPE	OMLARA	MUYIBAT		
10	YAHAYA	SULE	MAKAMA		
11	TOCHUKWU	EZE			
12	EGIEGBA	PAUL	UDO		
13	OKAFOR	CHUMMUA	SOLOMON		

You will notice that the contents and the entire row are deleted.

Note: Do not let the 4 which is the row heading confuse you. Row or column headings are not deleted. And to prove that the entire row was deleted, check the records of **Okafor Vivian Ada** that were in row 5; where are they now? They are now in row 4.



on the

Please remember to click the **undo Icon standard tools bar** or press **Ctrl + Z** to bring back the row and the contents.

Note: Excel deletes the row or column and shifts other adjacent rows and columns in the worksheet to fill the space.

4.0 CONCLUSION

Cell could be edited through the formula bar, pressing the F2 key or by double clicking the mouse to get editing mode of the cell.

5.0 SUMMARY

All windows application programmes have common method of executing some commands. For instance Cut, Copy, Save, Close, Undo, Redo etc have the same procedure of applying them in every windows application programs.

6.0 TUTOR-MARKED ASSIGNMENT

1. Differentiate between a workbook and worksheet
2. Explain the following terms
 - (i) Cell
 - (ii) Row
 - (iii) Column
 - (iv) Range
3. Mention the keyboard keys you should press if you want to see the last Row and Column of worksheet.
4. Mention any toolbar that is peculiar to MS Excel in comparison with MS-Word. Compare and contrast the menu bar of MS-Word and Ms-Excel.

7.0 REFERENCES/FURTHER READINGS

- French, C.S. (2000). *Computer Science*, Asfifor Colour Press: Gosport Hants, 5th Edition.
- Petroleum Training Institute (PTI), (1999). *Lecture Manual on Word Processing*, Warri.

UNIT 2 MS-EXCEL CONTINUED: FORMATTING AND EDITING OF WORKSHEET DATA

CONTENTS

- 1.0 Introduction
- 2.0 Objectives
- 3.0 Main Content
 - 3.1 Inserting Rows and Columns
 - 3.2 Inserting a New Worksheet
 - 3.3 Renaming Worksheet
 - 3.4 Worksheet Protection
 - 3.5 Deleting Worksheet
 - 3.6 Hide and Unhide Commands
 - 3.7 Filling Data
 - 3.8 Series
 - 3.9 Aligning Worksheet Data
 - 3.10 Text Orientation
 - 3.11 Formatting Text Font, Bold, Italics Colour and Underline
- 4.0 Conclusion
- 5.0 Summary
- 6.0 Tutor-Marked Assignment
- 7.0 References/Further Readings

1.0 INTRODUCTION

You will learn in this unit more commands that you can use to edit and format a worksheet. Also you will learn how to save time when typing data that have preset fillings in Excel.

2.0 OBJECTIVES

After you have studied this unit, you should be able to:

- insert rows, columns into a worksheet
- insert a new worksheet and rename worksheet
- protect and delete a worksheet
- hide and unhide columns and rows
- fill preset data
- align worksheet data
- change the Orientation of text.

3.0 MAIN CONENT

3.1 Inserting Rows and Columns

After you have entered data on the worksheet you may want to insert blank columns/rows in order to create room for new data or to include more empty space in the data area

Practice 1

How to Insert Rows or Columns

- Load the document – **Excel Tutor**

We shall insert 3 rows to enter the general headings for the database

	A	B	C	D	E	F
1	SURNAME	FIRST NANE	MIDDLE NAME	ENG. LAN	MATHEM	SOCIAL S
2	OJEYEMI	BIOLA	FAITH	45	58	92
3	ADADU	PIUS		39	58	24
4	OKAFOR	VIVIAN		54	84	57
5	JACKSON	TITILAY		62	43	58
6	IYERE	JOHN		48	49	47
7	OKAFOR	FRANK		47	45	76
8	BELLO	SARAH		81	67	48
9	TOPE	OMLAF		47	38	54
10	YAHAYA	SULE		47	59	47
11	TOCHUKWU	EZE		45	47	23
12	ENIENBA	DAJI		40	70	42

> Select the **first three rows**

> **Right click** on any part of the selected area, and then locate **Insert** command and click on it.

The result of the database will now be like the immediate one below.

	A	B	C	D	E
1					
2					
3					
4	SURNAME	FIRST NANE	MIDDLE NAME	ENG. LAN	MATHEM
5	OJEYEMI	BIOLA	FAITH	45	58
6	ADADU	PIUS	JAMES	39	58
7	OKAFOR	VIVIAN	ADA	54	84
8	JACKSON	TITILAYO	SAMUEL	62	43
9	IYERE	JOHN	SOLOMON	48	49
10	OKAFOR	FRANK		47	45
11	BELLO	SARAH	BIOLA	81	67
12	TOPE	OMLARA	MUYIBAT	47	38
13	YAHAYA	SULE	MALYAMA	47	50

Click on cell **A1** and type SKY LIMIT SECONDARY SCHOOL

Click on cell **A2** and type IGBOBI ROAD, YABA, LAGOS

Click on cell **A3** and type FIRST TERM EXAMINATION

	A	B	C	D	E
1	SKY LIMIT SECONDARY SCHOOL				
2	IGBOBI ROAD, YABA, LAGOS				
3	EIRST TERM EXAMINATION				
4	SURNAME	FIRST NANE	MIDDLE NAME	ENG. LAN	MATHEM
5	OJEYEMI	BIOLA	FAITH	45	58
6	ADADU	PIUS	JAMES	39	58
7	OKAFOR	VIVIAN	ADA	54	84
8	JACKSON	TITILAYO	SAMUEL	62	43
9	IYERE	JOHN	SOLOMON	48	49

Result of the database after typing the general headings

Let us assume that one of the subjects (INTRO TECH) was forgotten, and YOU are required to enter the data between MATHEMATICS and SOCIAL STUDIES. The marks, starting from the first student to the last are as follows: 40, 36, 67, 72, 44, 28, 39, 50, 81, 84, 72, 49, 33, 74, 49, 53, 47, 39 and 50.

	B	C	D	E	F	G	H
1	CONDARY SCHOOL						
2	, YABA, LAGOS						
3	EXAMINATION						
4	FIRST NAME	MIDDLE NAME	ENG.LAN	MATHEMA	SOCI		
5	BIOLA	FAITH	45	58			
6	PIUS	JAMES	39	58			
7	VIVIAN	ADA	54	84			
8	TITILAYO	SAMUEL	62	43			
9	JOHN	SOLOMON	48	49			
10	FRANK		47	45			
11	SARAH	BIOLA	81	67			
12	OMLARA	MUYIBAT	47	38			
13	SULE	MAKAMA	47	59			
14	F7F		45	47			

Select **column F** that contains Social Studies
 Locate **Insert** command and click on it.
 Enter the **data** supplied above in the new column

	A	B	C	D	E	F	G
1	SKY LIMIT SECONDARY SCHOOL						
2	IGBOBI ROAD, YABA, LAGOS						
3	EIRST TERM EXAMINATION						
4	SURNAME	FIRST NAME	MIDDLE NAME	ENG.LAN	MATHEMA	INTRO TEC	SOCIAL S'HO
5	OJEYEMI	BIOLA	FAITH	45	58	40	92
6	ADADU	PIUS	JAMES	39	58	36	24
7	OKAFOR	VIVIAN	ADA	54	84	67	57
8	JACKSON	TITILAYO	SAMUEL	62	43	72	58
9	IYERE	JOHN	SOLOMON	48	49	44	47
10	OKAFOR	FRANK		47	45	28	76
11	BELLO	SARAH	BIOLA	81	67	39	48
12	TOPE	OMLARA	MUYIBAT	47	38	50	54
13	YAHAYA	SULE	MAKAMA	47	59	81	47
14	TOCHUKWU	EZE		45	47	84	23
15	45	47	72	45

Result of the database after inserting a column to enter the data of Intro Tech that was forgotten

3.2 Inserting a New Worksheet

At default, Excel provides three sheets, however you can insert more sheets as you wish whenever the need arises.

Practice 2

How to insert a Worksheet

- Activate the **insert** menu
- Click **worksheet**

Look at the sheet tabs on the scroll bar, you will notice that they are now four, and sheet 1 is no longer the first sheet. Follow the procedure below to rearrange the sheets in order

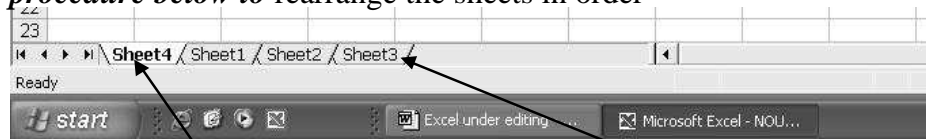

Click on the **sheet tab** – sheet 4 in this case, then hold and drag until where the mouse pointer is at the **position** you want to drop it – i.e. after sheet 3 in this case. You will notice that the mouse pointer will change to this shape  as you are dragging.



Result of the database after rearranging the sheets

3.3 Renaming Worksheet

Worksheets are often renamed based on the data they are holding for easy identification.

Practice 3

How to rename worksheet

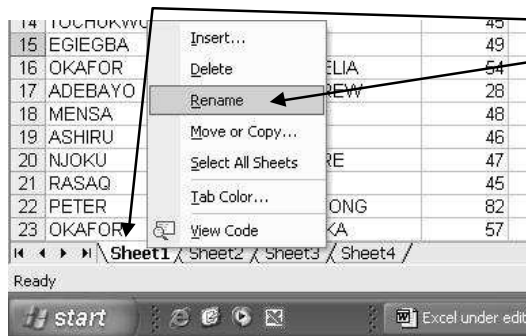

Right click on the **sheet tab** and Click **rename** option
You will notice a dark highlight on the sheet tab.
Type the new name – in this case **JSS 1 Exams**. Press any of the 4 arrow keys to get the insertion mode for editing

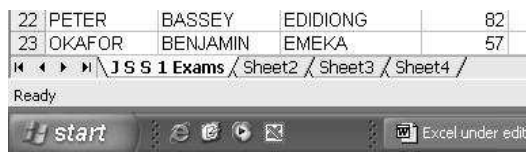

Nature of the database after renaming the sheets

3.4 Worksheet Protection

Worksheet protection enables user to prevent unauthorized person to have access to the worksheet data. Therefore, password is necessary and not optional as the computer may suggest.

Practice 4

How to Protect Worksheet

- Open the **worksheet**
- Activate the **tools menu**
- Locate **protection** and click **worksheet** option

The protect sheet dialog box such as the one below will come up.

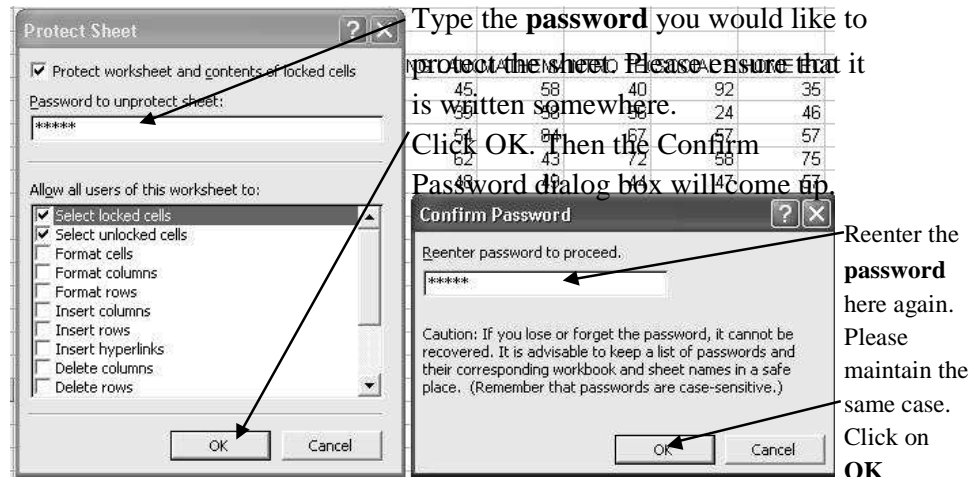

Attempt to enter data or delete the existing one. What is the message?

Practice 5

How to remove Worksheet Protection

- Open the **worksheet**
- Activate the **tools** menu
- Locate **protection** and click **unprotect** option

The unprotect sheet dialog box such as the one below will come up.

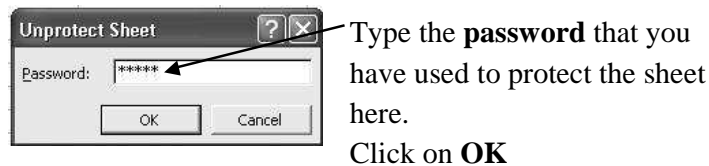

Attempt to enter data or delete the existing one again. Is it possible now?

3.5 Deleting Worksheet

This command allows you to remove a worksheet from the workbook. And bear in mind that once you execute your command, there is no way you can reverse the action.

If the sheet contains data, the office assistance will bring out a warning message of the inherent danger of deleting a sheet. Ignore the warning if you really want to delete the sheet. However, bear in mind that there is no way you can recover the sheet.

Practice 6

How to Delete Worksheet

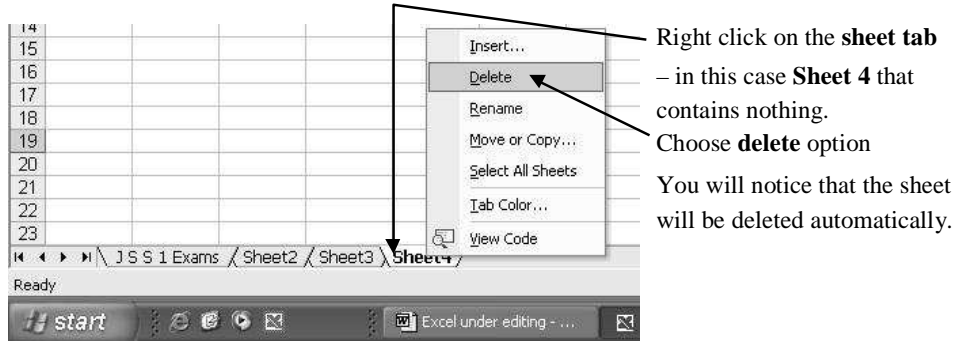

3.6 Hide and Unhide Commands

Columns and rows are hidden in order to bring other columns/rows outside the screen view into focus instead of scrolling the scroll bars. It makes entries of records within a database very convenient that has many field headings that may not be at focus at once even though the monitor size is 15 inches and above. However, you can reveal the hidden columns or rows anytime you need them by using the unhide command.

Practice 7

How to Hide Column(s) or Row(s)

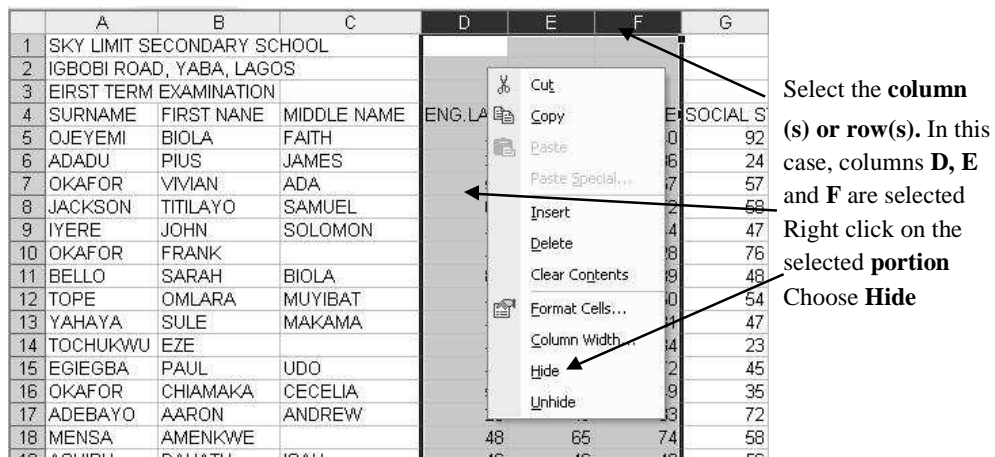

	A	B	C	G	H	I	J
1	SKY LIMIT SECONDARY SCHOOL						
2	IGBOBI ROAD, YABA, LAGOS						
3	FIRST TERM EXAMINATION						
4	SURNAME	FIRST NAME	MIDDLE NAME	SOCIAL S	HOME ECONS		
5	OJEYEMI	BIOLA	FAITH	92	35		
6	ADADU	PIUS	JAMES	24	46		
7	OKAFOR	VIVIAN	ADA	57	57		
8	JACKSON	TITILAYO	SAMUEL	58	75		

You can see that after **column C**, the next one is **column G**. That tells you that **columns D, E and F** are hidden.

Optional method

- Select the **column or row**
- Activate the **format menu**
- Locate **row, column**
- Click on **Hide** command

Practice 8

How to Unhide Rows or Columns

	A	B	C	G
5	OJEYEMI	BIOLA	FAITH	92
6	ADADU	PIUS	JAMES	24
7	OKAFOR	VIVIAN	ADA	57
8	JACKSON	TITILAYO	SAMUEL	
9	IYERE	JOHN	SOLOMON	
10	OKAFOR	FRANK	BIOLA	
11	BELLO	SARAH	MUYIL	
12	TOPE	OMLARA	MAKAMA	
13	YAHAYA	SULE	UDO	
14	TOCHUKWU	EZE	CECE	
15	EGIEGBA	PAUL	ANDREW	
16	OKAFOR	CHIAMAKA	ISAH	
17	ADEBAYO	AARON	EBERHARDT	
18	MENSA	AMENKWE	EDIDI	
19	ASHIRU	DAHATU	EMEKAKA	54
20	NJOKU	CALISTA		
21	RASAQ	TITILOPE		
22	PETER	BASSEY		
23	OKAFOR	BENJAMIN		

Select the **two adjacent columns/rows** by the **hidden columns/rows** – in this case, **columns C and G**. Please if you cannot recognize the hidden columns/rows, select the **whole worksheet**. Right click on the selected **portion**. Choose **Unhide** command

Optional method

- Select the **adjacent row or column** by the side of the hidden one
- Activate the **format menu**
- Locate **row or column**
- Click **unhide** option.

3.7 Filling Data

Excel provides easy way of filling the preceding data in the next cell(s) instead of typing it.

It saves time that would have been spent on retyping the same entry. It is also evident in filling series of data that have preset filling in Excel e.g. days, months, serial numbers etc.

Practice 9

Please click on sheet 2 tab for the following practical exercises

How to Fill in the Cell with the Contents above i

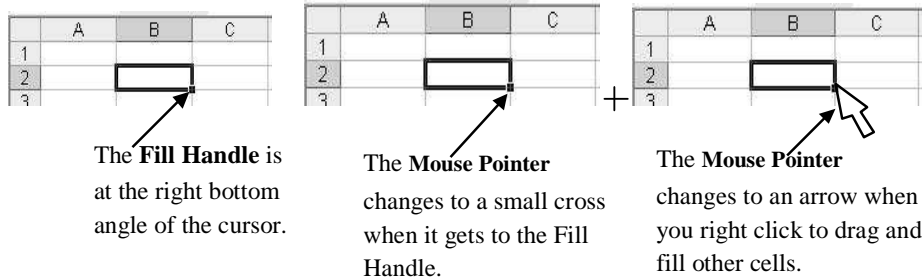

Type Good in cell B2 as shown below

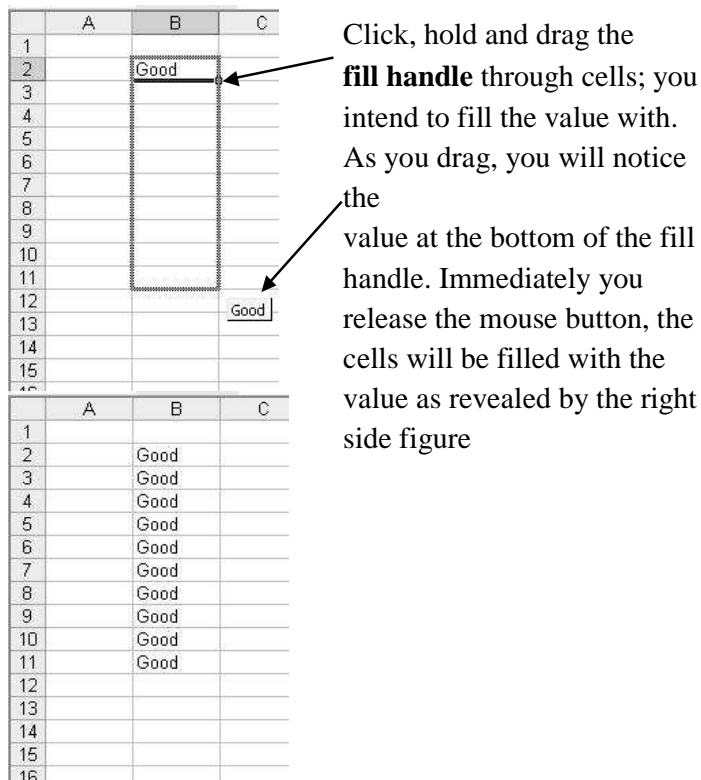

Optional Method

Type John in cell B2 and use the following procedures to repeat it in cells C2 and B3 respectively.

	A	B	C	D	E
1					
2		John			
3					
4					
5					
6					
7					
8					

If you want to type John in cell C2, position the cursor in the cell and press **Ctrl + R**.

And if you want to repeat it in the cell below, i.e. cell B3, position the cursor in the cell and press **Ctrl + D**.

Practice 10

How to Fill Days and Months

Let us assume that you want to start typing days from Tuesday to Thursday the following week or months from January to August the same year; follow the method below to do that.

Type the first value in any cell of your choice – in this case, Tuesday and January or the short forms (Tue and Jan).

B	C	D
	Tuesday	
		Thursday

Click, hold and drag the **fill handle** through the cells until you reach the desired day; then release your mouse

B	C	D
	Tuesday	
	Wednesday	
	Thursday	
	Friday	
	Saturday	
	Sunday	
	Monday	
	Tuesday	
	Wednesday	
	Thursday	

Result after releasing the mouse

	A	B	C	D	E	F	G	H	I
1									
2		Jan							
3									Aug
4									

Click, hold and drag the **fill handle** through the cells until you reach the desired month; then release your mouse

	A	B	C	D	E	F	G	H
1								
2	Jan	Feb	Mar	Apr	May	Jun	Jul	Aug
3								

Result after releasing the mouse

3.8 Series

Series are certain data that have preset filling in Microsoft Excel.

Practice 11

How to fill series of Numbers

Let us assume that you intend to enter students' serial numbers from 1 to 90

Type the first number e.g. 1 in the cell where you want to start

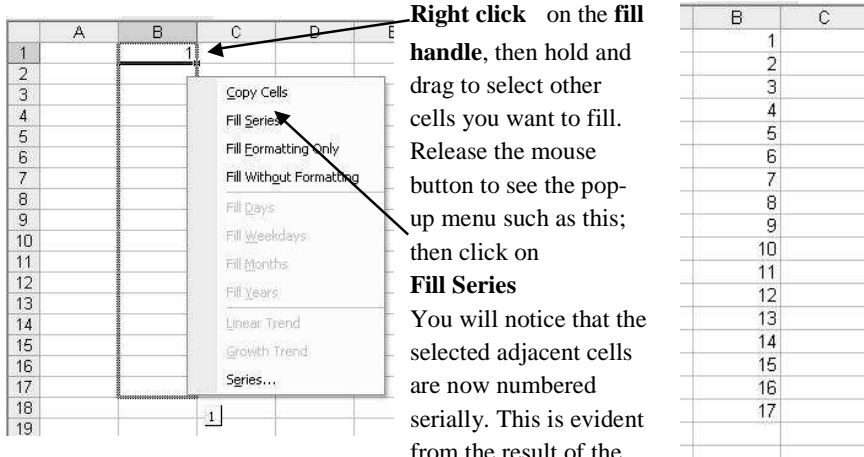

Right click on the **fill handle**, then hold and drag to select other cells you want to fill. Release the mouse button to see the pop-up menu such as this;

Fill Series

You will notice that the selected adjacent cells are now numbered serially. This is evident from the result of the demonstration by the right

Please extend your selection to many cells for more understanding

3.9 Aligning Worksheet Data

By default, **texts** are automatically aligned to the left in a cell, **numbers** are aligned to the right and **logical** and **error** values are centered. However, you can format cell entries and text such that the data are aligned the way you want – left, right or center of a cell. You can also extend characters across range of cells; rotate text across columns etc.

Practice 12

How to Merge and Center Cells Entries

The three general headings of our database are used for the practical exercise. Note that the general headings entries are in cells A1, A2 and A3 respectively; and the database last column is H. therefore, if you want to spread the headings across the columns, select each heading

starting from the first cell through the last cell, or from the last cell through the first cell and click on merge and center Icon  on the formatting tools bar.

	A	B	C	D	E	F	G	H
1	SKY LIMIT SECONDARY SCHOOL							
2	IGBOBI ROAD, YABA, LAGOS							
3	FIRST TERM EXAMINATION							
4	SURNAME	FIRST NAME	MIDDLE NAME	ENG. LANG	MATHEM	INTRO TE	SOCIAL S	HOME EC
5	OJAYEMI	BIOLA	FAITH	45	58	40	92	35
6	ADADU	PIUS	JAMES	39	58	36	24	46
7	OKAFOR	VIVIAN	ADA	54	84	67	57	57
8	JACKSON	TITILAYO	SAMUEL	62	43	72	58	75
9	IYERE	JOHN	SOLOMON	48	49	44	47	57
10	OKAFOR	FRANK		47	45	28	76	47
11	BELLO	SARAH	BIOLA	81	67	39	48	47
12	TOPE	OMLARA	MUYIBAT	47	38	50	54	12
13	YAHAYA	SULE	MAKAMA	47	59	81	47	45
14	TOCHUKWU	EZE		45	47	84	23	25
15	EGIEGBA	PAUL	UDO	49	78	72	45	46
16	OKAFOR	CHIAMAKA	CECELIA	54	58	49	35	24
17	ADEBAYO	AARON	ANDREW	28	49	33	72	28
18	MENSA	AMENKWE		48	65	74	58	24
19	ASHIRU	DAHATU	ISAH	46	46	49	56	57
20	NJOKU	CALISTA	EBERE	47	78	53	58	87
21	RASAQ	TITILOPE		45	58	47	49	54
22	PETER	BASSEY	EDIDIONG	82	59	39	75	56
23	OKAFOR	BENJAMIN	EMEKA	57	57	50	54	47

For example select the range of cells (A2:H2) and then click on merge and center Icon  on the formatting tools bar.

Please do not select the three headings at the same time.



Other alignment buttons can be used to align text to the left center and left of the cell. We have seen these in MS-Word already.

	A	B	C	D	E	F	G	H
1	SKY LIMIT SECONDARY SCHOOL							
2	IGBOBI ROAD, YABA, LAGOS							
3	FIRST TERM EXAMINATION							
4	SURNAME	FIRST NAME	MIDDLE NAME	ENG. LANG	MATHEM	INTRO TE	SOCIAL S	HOME EC
5	OJAYEMI	BIOLA	FAITH	45	58	40	92	35
6	ADADU	PIUS	JAMES	39	58	36	24	46
7	OKAFOR	VIVIAN	ADA	54	84	67	57	57
8	JACKSON	TITILAYO	SAMUEL	62	43	72	58	75
9	IYERE	JOHN	SOLOMON	48	49	44	47	57
10	OKAFOR	FRANK		47	45	28	76	47
11	BELLO	SARAH	BIOLA	81	67	39	48	47
12	TOPE	OMLARA	MUYIBAT	47	38	50	54	12
13	YAHAYA	SULE	MAKAMA	47	59	81	47	45
14	TOCHUKWU	EZE		45	47	84	23	25
15	EGIEGBA	PAUL	UDO	49	78	72	45	46
16	OKAFOR	CHIAMAKA	CECELIA	54	58	49	35	24
17	ADEBAYO	AARON	ANDREW	28	49	33	72	28
18	MENSA	AMENKWE		48	65	74	58	24
19	ASHIRU	DAHATU	ISAH	46	46	49	56	57
20	NJOKU	CALISTA	EBERE	47	78	53	58	87
21	RASAQ	TITILOPE		45	58	47	49	54
22	PETER	BASSEY	EDIDIONG	82	59	39	75	56
23	OKAFOR	BENJAMIN	EMEKA	57	57	50	54	47

For example select the range of cells (D5:H23) that contain the numeric data and then click  Align center Icon on the formatting tools bar.

Please do not select all the general headings at the same time to merge and center.

3.10 Text Orientation

Text orientation is a way of changing the direction of text to any angle (0° – 90°) of your choice. It is good for field headings when a database contains many field headings that are needed in one sheet of a hard copy.

Practice 13

How to change the orientation of text to take different angles

- Select the **cells** that contain the **field headings** or select the **whole row**. In this case, **row 4** is selected.
- Activate the **format menu**
- Click on **Cells**

The format cell dialog box like the one below will come up.

Click on the **Alignment** tab, if it has not opened at default.

Click on the **red button**, then hold and drag to take any angle either up (+ve) or down (-ve). Note that yours will be at 0°.

Also, you can **type** or **scroll** to get the required angle.

Click on **OK** to execute your action

	A	B	C	D	E	F	G	H
1	SKY LIMIT SECONDARY SCHOOL							
2	IGBOBI ROAD, YABA, LAGOS							
3	FIRST TERM EXAMINATION							
4	SURNAME	FIRST NAME	MIDDLE NAME	ENG. LANGUAGE	MATHEMATICS	INTRO TECH	SOCIAL STUDIES	HOME ECONS
5	OJEYEMI	BIOLA	FAITH	45	58	40	92	35
6	ADADU	PIUS	JAMES	39	58	36	24	46
7	OKAFOR	VIVIAN	ADA	54	84	67	57	57
8	JACKSON	TITILAYO	SAMUEL	62	43	72	58	75
9	IYERE	JOHN	SOLOMON	48	49	44	47	57
10	OKAFOR	FRANK		47	45	28	76	47
11	BELLO	SARAH	BIOLA	81	67	39	48	47
12	TOPE	ONLARA	MUYIBAT	47	38	50	54	12
13	YAHAYA	SULE	MAKAMA	47	59	81	47	45
14	TOCHUKWU	EZE		45	47	84	23	25
15	EGIEGBA	PAUL	UDO	49	78	72	45	46
16	OKAFOR	CHIAMAKA	CECELIA	54	58	49	35	24
17	ADEBAYO	AARON	ANDREW	28	49	33	72	28

Nature of the database after orientation

Note: You can take any orientation as you like. For example, take -90° and 45° and see the result. Please select **row 4** and center aligned the **fields headings**

3.11 Formatting Text Font, Bold, Italics Colour and Underline

The procedures to format text font, bold, italics colour and underline in MS-Word is the same in MS-Excel. However, for the longer method, activate the format menu, click on cell option and the cell dialog box we

used above for orientation will come up. Click on Font tab and carry out your formats as usual.

Practice 14

- i. Select the **general headings**, apply **bold format** and increase the **font size to 14**
- ii. Select the **fields' headings**, apply **bold format** and increase the **font size to 12**

	A	B	C	D	E	F	G	H
1	SKY LIMIT SECONDARY SCHOOL							
2	IGBOBI ROAD, YABA, LAGOS							
3	FIRST TERM EXAMINATION							
4	SURNAME	FIRST NAME	MIDDLE NAME	ENG. LANGUAGE	MATHEMATICS	INTRO TECH	SOCIAL STUDIES	HOME ECONCS
5	QJEYEMI	BIOLA	FAITH	45	58	40	92	35
6	ADADU	PIUS	JAMES	39	58	36	24	46
7	OKAFOR	VIVIAN	ADA	54	84	67	57	57
8	JACKSON	TITILAYO	SAMUEL	62	43	72	58	75
9	IYERE	JOHN	SOLOMON	48	49	44	47	57
10	OKAFOR	FRANK		47	45	28	76	47
11	BELLO	SARAH	BIOLA	81	67	39	48	47
12	TOPE	OMLARA	MUYIBAT	47	38	50	54	12
13	YAHAYA	SULE	MAKAMA	47	59	81	47	45
14	TOCHUKWU	EZE		45	47	84	23	25

Nature of the database after applying the above specified formats

4.0 CONCLUSION

Rows and column could be inserted into a data base for more information whenever the need arises

5.0 SUMMARY

Excel database could be protected to prevent unauthorized person to have access to it. Although password is optional, it is necessary because somebody can have access to the database without your knowledge if password was not used. The user himself may not be able to have access to his data if he forgets the password, therefore you are advised to write password in a secrete and safe place.

6.0 TUTOR-MARKED ASSIGNMENT

1. What is the disadvantage of deleting a worksheet from a workbook?
2. Describe the position where the fill handle is located in the mouse pointer.
3. You are asked to number a series from number 1 – 100. Type 1 (one) in any cell and then use the fill handle to fill the other numbers i.e. 2 –100.

7.0 REFERENCES/FURTHER READINGS

Petroleum Training Institute (PTI), (1999). *Lecture Manual on Spreadsheet Management*, Warri.

French, C.S. (2000). *Computer Science*, Asfifor Colour Press: Gosport Hants, 5th Edition.

UNIT 3 MS-EXCEL CONTINUED

MORE FORMATTING AND EDITING OF WORKSHEET DATA

CONTENTS

- 1.0 Introduction
- 2.0 Objectives
- 3.0 Main Content
 - 3.1 Copying, Cutting and Pasting Data
 - 3.2 Undo and Redo Command
 - 3.3 Sorting Data
 - 3.4 Assigning Number Format
 - 3.5 Formatting with Borders
 - 3.6 Formatting with Pattern or Shading
 - 3.7 Header and Footer
- 4.0 Conclusion
- 5.0 Summary
- 6.0 Tutor-Marked Assignment
- 7.0 References/Further Readings

1.0 INTRODUCTION

In addition to what you had known in Ms-Word on how to paste copied and cut text, also to use the paste command in Excel, position the cursor in the first cell where you want the range of entries and then activate the paste command. Additionally, this unit considers shading, number and orientation formats of selected cells.

2.0 OBJECTIVES

At the end of this unit, you should be able to:

- paste copy or cut cells entries
- sort data either in ascending or descending order
- assign number formats
- apply pattern or shading format
- apply border to selected cells
- use header and footer for more information.

3.0 MAIN CONTENT

3.1 Copying, Cutting and Pasting Data

The same approaches of how to copy, cut and paste text in MS-Word are still applicable here. However, the aspect of how to paste copied /cut data is highlighted below because of some slight differences.

Practice 1

How to copy or Cut Text

Load your **document (MS-Excel Tutor)**

Let us copy the content of cells **B1:D9** to **sheet 3** to occupy a range of cells – **starting from cell C3**.

	A	B	C	D	E	F	
1		SKY LIMIT SECONDARY SCHOOL					
2		IGBOBI ROAD, YABA, LAGOS					
3		FIRST TERM EXAMINATION					
4		SURNAME	FIRST NAME	MIDDLE NAME	ENG. LANGUAGE	MATHEMATICS	INTRO TECH
5		OJEYEMI	BIOLA	FAITH	45	58	40
6		ADADU	PIUS	JAMES	39	58	36
7		OKAFOR	VIVIAN	ADA	54	84	67
8		JACKSON	TITILAYO	SAMUEL	62	43	72
9		IYERE	JOHN	SOLOMON	48	49	44
10		OKAFOR	FRANK		47	45	28

Select the **range of cells** you intend to copy or cut. Use any **copy** or **cut** command known to you to copy or cut the selected cells.

Hint: you can use **copy** icon or **cut** icon on the **standard tools bar**.

You will notice a **shaking border** around the selected cells. Do not panic, if it is still there after pasting, press **Esc (Escape)** key.

Practice 2

How to paste Copied or Cut Text

Since you were asked to paste the content **starting from cell C3**, just place your cursor in **cell C3** as shown below:

	A	B	C	D	E
1					
2					
3					
4					
5					
6					
7					

Place the cursor in **cell C3** and use any **paste command** known to you to paste the copied or cut cells

Hint: You can use **paste icon** on the **standard tools bar**.

	A	B	C	D	E	F
1						
2						
			FIRST NAME	MIDDLE NAME	ENG. LANGUAGE	
3						
4			BIOLA	FAITH	45	
5			PIUS	JAMES	39	
6			VIVIAN	ADA	54	
7			TITILAYO	SAMUEL	62	
8			JOHN	SOLOMON	48	
9						

This is the outcome of the pasted cells in sheet 3

The message I want to pass across is that you should not bother how you paste copied or cut cells; even though a whole sheet is copied, just place the cursor in the first cell where you want the copied or cut cells to start and then paste.

3.2 Undo and Redo Commands

Please refer to the notes on undo and redo commands in MS-Word

3.3 Sorting Data

Sorting data in MS-Excel is similar to sorting Table data in MS-Word. It is used to rearrange data in a worksheet either alphabetically or numerically in ascending or descending order, for easy retrieval of data or reference to data.

Practice 3

How to Sort Data

- Select the **range** of cells you want to sort. In this case, we shall sort the whole database. Therefore start your selection from the first field heading and drag to the last cell that contains the data of the database. Example of how to select the database before sorting is shown below. *Please do not include the general headings.*

Note: Some of the subsequent databases are incomplete because of the 90° orientation of the fields' headings. Therefore, you should not follow exactly what is in the book whenever the whole database is referred to. It is what the screen could display by the time it was copied that you are seeing here.

	A	B	C	D	E	F	G	H
1	SKY LIMIT SECONDARY SCHOOL							
2	IGBOBI ROAD, YABA, LAGOS							
3	FIRST TERM EXAMINATION							
4	SURNAME	FIRST NAME	MIDDLE NAME	ENGLANGUAGE	MATHEMATICS	INTRO TECH	SOCIAL STUDIES	HOME ECONS
5	OJEYEMI	BIOLA	FAITH	45	58	40	92	35
6	ADADU	PIUS	JAMES	39	58	36	24	46
7	OKAFOR	VIVIAN	ADA	54	84	67	57	57
8	JACKSON	TITILAYO	SAMUEL	62	43	72	58	75
9	IYERE	JOHN	SOLOMON	48	49	44	47	57
10	OKAFOR	FRANK		47	45	28	76	47
11	BELLO	SARAH	BIOLA	81	67	39	48	47
12	TOPE	OMLARA	MUYIBAT	47	38	50	54	12
13	YAHAYA	SULE	MAKAMA	47	59	81	47	45
14	TOCHUKWU	EZE		45	47	84	23	25

Click on the **first cell (A4)** of the **range**, then hold and drag until the selection gets to the **last cell (H23)**.
Please do not use the row heading (4) to select. It will select the whole row.

- From the **data menu** choose sort.

The Sort dialog box such as the one below will come up

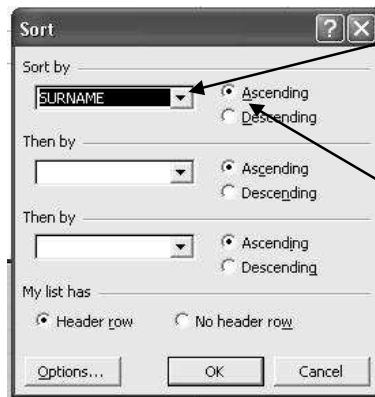

Click on the **down facing arrow (▼)** arrow by the side of **Sort by** box if you want to use another field heading apart from the default one, and then select the field heading from the drop down list.
Select either **Ascending** or **Descending** as the case may be.
Click **OK**.

The result of the database after sorting it in ascending order is revealed below. Have you noticed something? Look at the four surnames – Okafor. In line with their **first names**, who comes first? Benjamin of course!

	A	B	C	D	E	F	G	H
	SURNAME	FIRST NAME	MIDDLE NAME	ENGLANGUAGE	MATHEMATICS	INTRO TECH	SOCIAL STUDIES	HOME ECONS
4								
5	ADADU	PIUS	JAMES	39	58	36	24	46
6	ADEBAYO	AARON	ANDREW	28	49	33	72	28
7	ASHIRU	DAHATU	ISAH	46	46	49	56	57
8	BELLO	SARAH	BIOLA	81	67	39	48	47
9	EGIEGBA	PAUL	UDO	49	78	72	45	46
10	IYERE	JOHN	SOLOMON	48	49	44	47	57
11	JACKSON	TITILAYO	SAMUEL	62	43	72	58	75
12	MENSA	AMENKWE		48	65	74	58	24
13	NJOKU	CALISTA	EBERE	47	78	53	58	87
14	OJEYEMI	BIOLA	FAITH	45	58	40	92	35
15	OKAFOR	VIMAN	ADA	54	84	67	57	57
16	OKAFOR	FRANK		47	45	28	76	47
17	OKAFOR	CHIAMAKA	CECELIA	54	58	49	35	24
18	OKAFOR	BENJAMIN	EMEKA	57	57	50	54	47
19	PETER	DISSEY	EDUONG	52	59	38	75	55

In order to sort the **first names** in ascending order, select the **whole database** just as you did the first time.

Activate the **Data menu** and click on Sort command to give you the **sort dialog box** again.

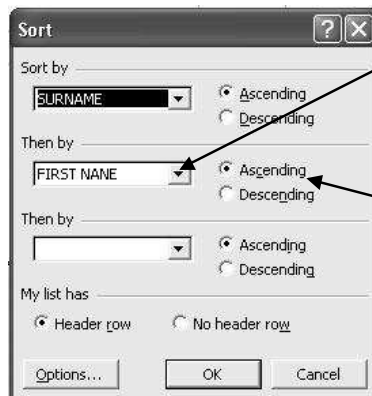

Click on the **down facing arrow** (▼) arrow by the side of **Then by** box to select the field heading (First Name now) from the drop down list.

Select either **Ascending** or **Descending** as the case may be.

Click **OK**

The outcome of the database after using **First Name field heading** to sort is shown below. What is the situation of the Okafors now? The first names are now in alphabetical (ascending) order.

	A	B	C	D	E	F	G	H
	SURNAME	FIRST NAME	MIDDLE NAME	ENGLANGUAGE	MATHEMATICS	INTRO TECH	SOCIAL STUDIES	HOME ECNS
4								
5	ADADU	PIUS	JAMES	39	58	36	24	46
6	ADEBAYO	AARON	ANDREW	28	49	33	72	28
7	ASHIRU	DAHATU	ISAH	46	46	49	56	57
8	BELLO	SARAH	BIOLA	81	67	39	48	47
9	EGIEGBA	PAUL	UDO	49	78	72	45	46
10	IYERE	JOHN	SOLOMON	48	49	44	47	57
11	JACKSON	TITILAYO	SAMUEL	62	43	72	58	75
12	MENSA	AMENKWE		48	65	74	58	24
13	NJOKU	CALISTA	EBERE	47	78	53	58	87
14	OJAYEMI	BIOLA	FAITH	45	58	40	92	35
15	OKAFOR	BENJAMIN	EMEKA	57	57	50	54	47
16	OKAFOR	CHIAMAKA	CECELIA	54	58	49	35	24
17	OKAFOR	FRANK		47	45	28	76	47
18	OKAFOR	VIVIAN	ADA	54	84	67	57	57
19	PETER	DAVID	EMILSON	32	58	39	76	56

The **First Name** of the students whose Surnames are Okafor are now in ascending order

Note: You can still sort the third time in a situation where the surname and first name are the same. For instance let us assume that we have the following surname, first name and middle name such as:

Ayodele Oluwole Pius

AyodeleAhmed Sadiq



Ayodele Oluwole Babajide

Ayodele Kemi Shola

Ayodele Oluwole Femi.

In this case you will notice that after sorting the second time, Ayodele Oluwole Babajide will not be properly arranged. Therefore, you have to sort the third time as usual in order to arrange the middle name

Optional Method

- Select the **range of cells** you want to sort as explained under first method 
- Click on the **Sort Ascending Icon** on the Standard Tools Bar in order to sort the rows in ascending order. 
- Click on the **Sort Descending Icon** on the Standard Tools Bar to sort the rows in descending order.

Limitations of the Optional Method

- It does not provide room for selection of a different Field heading. It uses only the default field heading.
- There is no room for selection of second or third sort even though some of the names are the same.

3.4 Assigning Number Format

In Excel, all cells use the general number format as the default format. However, you can format a range to take the format you want in terms of numbering, date, currency etc.

Practice 4

How to assign a Number Format

Open **MS-Excel Tutor** document you have saved. Select sheet 2 or sheet 3 to do the exercise.

First, to prove that Excel does not count **zero digits** before **real digits** if it is not a decimal number, click **any cell** and type **00001**, then press Enter key or click any cell. What do you notice? It remains only 1.

Realizing that Excel does not recognize zero (0) digit before the real digit, and you want to prepare a database that has numbering such as 0001, 0002, 0003 etc, format the cells that will take the numbering to text.

- Select the empty **cells** you want to format. In this case column B is selected

	A	B	C	D	E	F
1						
2						
3						
4						
5						
6						
7						
8						
9						
10						
11						
12						
13						
14						
15						

Activate the **Format menu** and click on **cells**

Or right click on the **selected area** and then click on **Format cells**

The format cell dialog box such as the one below will come up.

EDUCATION

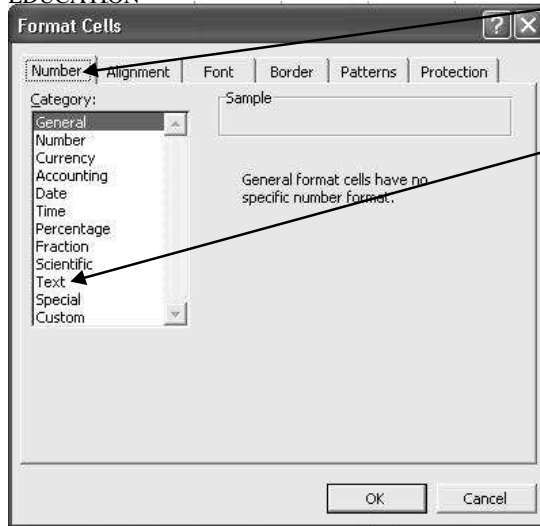

Click on the **Number** tab, if it has not opened at default.

Select **any format option**. In this case, **Text format** is selected

Click Ok

Type **0001** in cell **B1** now and press Enter key or click any cell. Is it there?

Place the cursor back in the cell, then **right click** on the fill handle and drag through the other cells to your desired number.

Click on **Fill Series**

3.5 Formatting with Borders

Although Excel Worksheet is in form of a table in MS-Word, it does not mean that the lines borders between Columns and Rows are printable. They are just gridlines to guide the user. Without any border format, you will get a plain sheet as your output after printing.

Click on sheet 1 i.e. J S S 1 Exam sheet and use the database for the practical exercise.

Select only the area that contains the data including the general headings. Example of such selection is shown below:

	A	B	C	D	E	F	G	H
1	SKY LIMIT SECONDARY SCHOOL							
2	IGBOBI ROAD, YABA, LAGOS							
3	FIRST TERM EXAMINATION							
4	SURNAME	FIRST NAME	MIDDLE NAME	ENG. LANGUAGE	MATHEMATICS	INTRO TECH	SOCIAL STUDIES	HOME ECNS
5	ADADU	PIUS	JAMES	39	58	36	24	46
6	ADEBAYO	AARON	ANDREW	28	49	33	72	28
7	ASHIRU	DAHATU	ISAH	46	46	49	56	57
8	BELLO	SARAH	BIOLA	81	67	39	48	47
9	EGIEGBA	PAUL	UDO	49	78	72	45	46
10	IYERE	JOHN	SOLOMON	48	49	44	47	57
11	JACKSON	TITILAYO	SAMUEL	62	43	72	58	75
12	MENSA	AMENKWE		48	65	74	58	24
13	NJOKU	CALISTA	EBERE	47	78	53	58	87
14	OJYEMI	BIOLA	FAITH	45	58	40	92	36

Please ensure that your selection covers every part you want to format with borders

Practice 5

How to work with Borders

Activate the **format menu** choose **cells** to give you **Format Cells dialog box** like the one below:

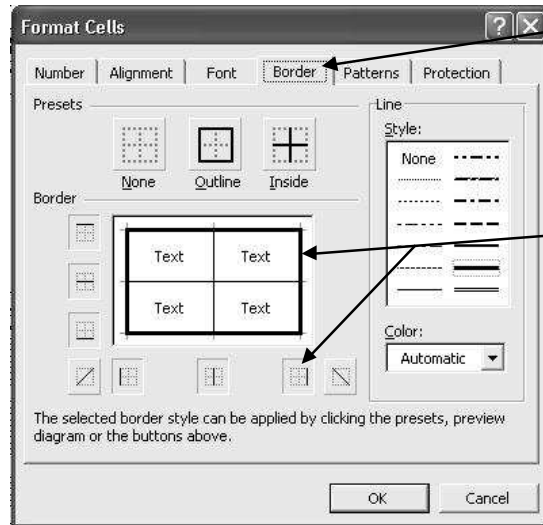

Click on **borders** tab, if it has not opened at default.
 Select Line Style – in this case, thick line for outside borders and single for inside borders.
 Click on **buttons** or **picture** to apply borders just the same way we formatted tables with borders in MS-Word
 Click on **Ok** command

	A	B	C	D	E	F	G	H
1	SKY LIMIT SECONDARY SCHOOL							
2	IGBOBI ROAD, YABA, LAGOS							
3	FIRST TERM EXAMINATION							
4	SURNAME	FIRST NAME	MIDDLE NAME	ENG. LANGUAGE	MATHEMATICS	INTRO TECH	SOCIAL STUDIES	HOME ECONCS
5	ADADU	PIUS	JAMES	39	58	36	24	46
6	ADEBAYO	AARON	ANDREW	28	49	33	72	28
7	ASHIRU	DAHATU	ISAH	46	46	49	56	57
8	BELLO	SARAH	BIOLA	81	67	39	48	47
9	EGIEGGBA	PAUL	UDO	49	78	72	45	46
10	IYERE	JOHN	SOLOMON	48	49	44	47	57
11	JACKSON	TITILAYO	SAMUEL	62	43	72	58	75
12	MENSA	AMENKWE		48	65	74	58	24
13	NJOKU	CALISTA	EBERE	47	78	53	58	87
14	OJEYEMI	BIOLA	FAITH	45	58	40	92	35

Result of the database after formatting it with borders.
Print Preview to check whether there are borders or not.

3.6 Formatting With Pattern or Shading

Patterns are used to apply colour to selected cells in order to lay emphasis on certain entries in a database.

Practice 6

How to format with Patterns or Shading

- Select the **cells** you intend to format with patterns/shading – in this case, select only the **field headings** and format them with yellow colour.

	A	B	C	D	E	F	G	H
1	SKY LIMIT SECONDARY SCHOOL							
2	IGBOBI ROAD, YABA, LAGOS							
3	FIRST TERM EXAMINATION							
4	SURNAME	FIRST NAME	MIDDLE NAME	ENG.LANGUAGE	MATHEMATICS	INTRO TECH	SOCIAL STUDIES	HOME ECON
5	ADADU	PIUS	JAMES	39	58	36	24	46
6	ADEBAYO	AARON	ANDREW	28	49	33	72	28
7	ASHIRU	DAHATU	ISAH	46	46	49	56	57

Selected **fields headings**

- Activate the **format** menu and click on **Cells** or right click on the **selected Cells** and click **Format Cells** Option.

The format cells dialog box will come up

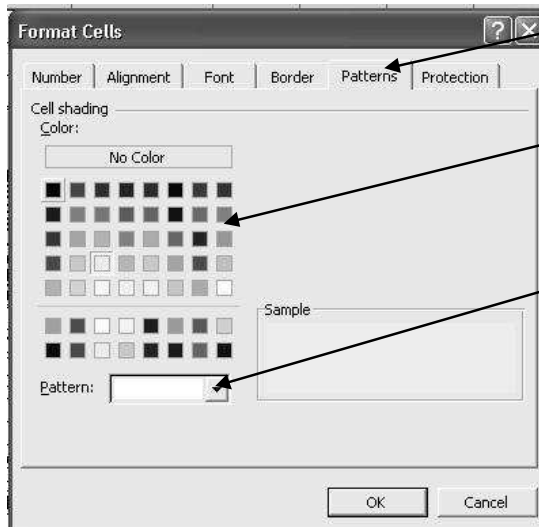

Click on **Patterns tab**, if it has not opened at default.

Select **any colour** or your choice to apply shading. This gives ordinary shading colour

Click on the **down facing arrow** by pattern box to select pattern colour shading.

Click on **Ok** command when you are through.

	A	B	C	D	E	F	G	H
1	SKY LIMIT SECONDARY SCHOOL							
2	IGBOBI ROAD, YABA, LAGOS							
3	FIRST TERM EXAMINATION							
4	SURNAME	FIRST NAME	MIDDLE NAME	ENG.LANGUAGE	MATHEMATICS	INTRO TECH	SOCIAL STUDIES	HOME ECONS
5	ADADU	PIUS	JAMES	39	58	36	24	46
6	ADEBAYO	AARON	ANDREW	28	49	33	72	28
7	ASHIRU	DAHATU	ISAH	46	46	49	56	57

Outcome of the Fields Headings after formatting with yellow shading colour.

Mine is on grayscale colour because of the print out of the book

Optional method

- Select the **cell or range of cell(s)**
- Click on the **Fill colour icon**  either on the formatting toolbar or on the drawing toolbar.
- Click on **any colour** of your choice.

3.7 Header and Footer

In MS-Word, header and footer was seen to give more information such as page numbering, footnotes etc about the document. In Excel the method of application is quite different from Word. Also, header and footer cannot be noticed on the worksheet except you print preview or print the hard copy of the worksheet.

Practice 7

How to format worksheet to have Header or Footer

- Activate the **View menu** and click on **Header and Footer command**

The page setup dialog such as the one below will appear

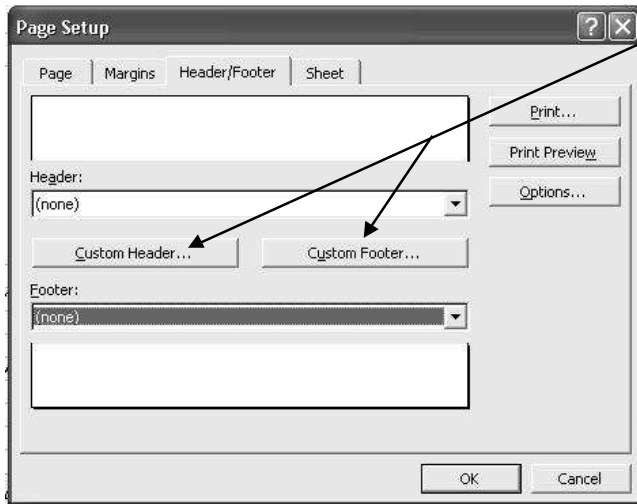

Click on either **Custom Header** or **Custom Footer** to apply the header or footer of your choice. Here, **Header** is chosen. And when you click on it, the following header dialog box will emerge. It has three sections that can be used for different headers. Click on any section you want to use. It is not compulsory that you must use the three.

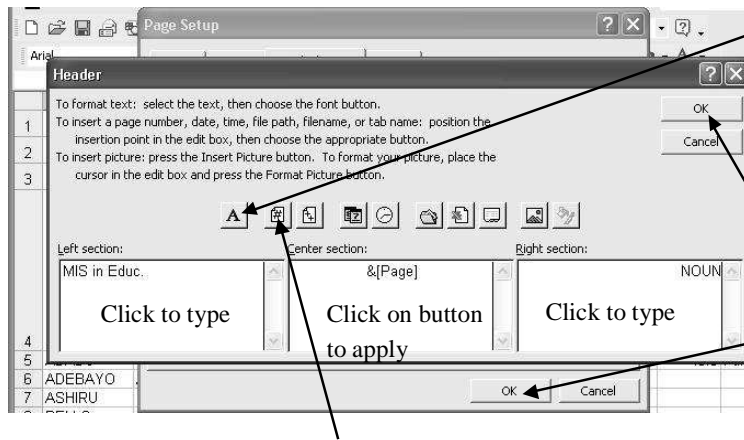

Click on this **font button** to format any of the headers, but you have to **select it first**. Click on **Ok** in the Header dialog box before you click on **OK** in the Page Setup dialog box.

Click on this **page numbering button** to apply page numbering. Note that you will not see the numbering in figures. What will appear is: **& [Page]**. You will see the real numbers in Print Preview or in hard copy.

4.0 CONCLUSION

The line border in excel worksheet, are grid lines hence they are not printable. Therefore any part of a worksheet where borders are expected to show must be formatted into boarder

5.0 SUMMARY

Worksheet entries could be entered anyhow undermining the arrangement, because it is possible to arrange them either in ascending or descending order based on any field heading of your choice.

6.0 TUTOR-MARKED ASSIGNMENT

1. State the limitations you encounter if you use the sort icons on the standard tools bar to sort a data base
2. Explain the procedure you would take to format worksheet into header and footer information

7.0 REFERENCES/FURTHER READINGS

French, C.S. (2000). *Computer Science*, Asfifor Colour Press: Gosport Hants, 5th Edition.

Petroleum Training Institute (PTI), (1999). *Lecture Manual on Spreadsheet Management*, Warri.

UNIT 4 MICROSOFT EXCEL CONTINUED DATABASE

CONTENTS

- 1.0 Introduction
- 2.0 Objectives
- 3.0 Main Content
 - 3.1 What is a Database?
 - 3.1.1 Database Management System (DBMS)
 - 3.2 Parts of a Database
 - 3.3 Editing a Database
 - 3.4 Formulae
 - 3.4.1 Types of Formula
 - 3.4.2 Samples of Excel Formula
 - 3.4.3 AutoSum Command
 - 3.5 Functions
 - 3.6 Filtering a Database
 - 3.6.1 Custom AutoFilter
 - 3.6.2 Wild Cards
 - 3.7 Printing
- 4.0 Conclusion
- 5.0 Summary
- 6.0 Tutor-Marked Assignment
- 7.0 References/Further Readings

1.0 INTRODUCTION

The usefulness of database in the administration of every organisation can not be over emphasized. In this unit, you will see how a database is created and used to get information as fast as possible.

2.0 OBJECTIVES

After completing this unit, you should be able to

- define a database and DBMS
- identify parts of a database
- create a database and edit it
- define format and know types of formula in Excel
- describe samples of Excel formula
- learn how to use AutoSum to sum up.

3.0 MAIN CONTENT

3.1 What is a Database?

Database is a comprehensive, consistent, controlled and coordinated collection of structured data items. In another form, it is a collection of huge amount of data under different fields made up of Records. Excel allows you to create a database on a worksheet. By using your worksheet data as a database, you can easily store and manipulate complex data or large amount of data.

Database is a comprehensive, consistent, controlled and co-ordinate collection of structured data items.

3.1.1 Database Management System (DBMS)

Is a programme which has access to all of an organisation's master files (i.e. organisation's database) and which can be used to interrogate files and generate required report?

DBMS provide facilities for different types of file processing for example, it can

- i. Provides a complete file (serially or sequentially).
- ii. Process required records (selective, sequential or random) The HOD may specify his requirement by instructing examination officer with **pseudo-English statement e.g. "show students who are below average."**

DBMS also has the function of providing security for the data in the base. For instance protecting data against unauthorized access.

However, apart from the overall database of the entire organization, individuals, departments and faculties can maintain their own database on Spreadsheet Management System for accurate and timely information acquisition and dissemination.

3.2 Parts of a Database

Before you can create a database, you need to understand and know the various parts of a database.

Field: The **first row** of the database contains the fields. **Each column** in a database is a separate field, and **each of the cells** within a column is a field which stores a basic unit of information e.g. **Name Age, sex,** etc.

Field name: A field name is a name that identifies the data stored in a field. The top row of a database must contain the field names; each column must have a field name. Though field names can take a maximum of 225 characters, it is best to keep field names brief.

In the figure below, **Name, I. D. Number, Course fee etc** are examples of field names.

	A	B	C	D	E	F
1	Names	I.D. Number	Course Fee	Amt. Paid	Balance	
2	Agbedor	456677	40000	36000	4000	
3	Ojor	944566	45000	40000	5000	
4	Agbodesi	344556	23000	20000	3000	
5	Alenoghena	237045	30000	30000	0	
6	Ikhsakue	568033	35000	30000	5000	
7						
8						

Data base Range: A database ranges is a rectangular range of a worksheet cell used as database;

Record: A record is a single row in a database

Computer Field: is a field that contains **formula** or **functions**.

How to create a Database

- Enter the **field names**.
- Enter the **records** in the rows below the field names.

Remember that we have already created one (Excel Tutor) in unit 1 of this module, formatted edited it in unit 2. We shall still continue with it. Therefore if you have deleted your own, try to build another one.

3.3 Editing a Database

You can edit a database using any of the editing techniques for worksheet, such as **adding** or deleting rows cutting or copying and pasting data. Please refer to unit 1 and 2 of this module.

3.4 Formulae

A formula is a set of instruction coded for calculation. It is made up of constant values; cell references names, functions or operators that produce a new value from existing value. Formula must be preceded with an equal to (=) or plus (+) or at (@) signs e.g. =C7 +B5, @SUM (D2:K14), +D5*F5, =PRODUCT (A1, D3, G5, H2), +AVERAGE

(A1:E15) etc. In brief, a formula cell must have the sign of equality (=), a function e.g. SUM and an argument e.g. M2:Q6

Operations such as addition, multiplication, comparison on the worksheet are performed with formulae. A formula combines value with operators to produce results.

3.4.1 Types of Formula

There are three types of formula

Arithmetic Formula: It calculates with numeric value using the arithmetic operators like +, -, *, ^, /

Text Formula: It calculates with text operator content of a cell. For example, the word **Kayode** in cell D3

Logical Formula: It compares two more values using relational operators like > (greater than), < (less than), = (equal to), >= (greater than or equal to), <= (less than or equal to),

Operators: These are mathematical symbols such as:

+	Addition
-	Subtraction
/	Division
*	Multiplication
^	Exponential
%	Percentage

3.4.2 Samples of Excel Formulae

=SUM (A4...K4) or =SUM (A4: K4) Sums up all the value in cells A4 to K4

=SUM (G2, Z10) or =G2+Z10 Sums up all the values in cells G2 and Z10

=AVERAGE (D4: H4) Computes the average value of all the numbers in cell D4 to H4

Note: Always try to ensure that the cursor is in the particular cell where you want the answer to your calculation to appear. Please do not press **space bar** in order to apply space (gap) when typing a formula. No space in between characters of a formula.



Practice 1

Required: Calculate the total and average

	A	B	C	D	E	F
1	Day 1	Day 2	Day 3	Total	Average	
2	10000	20000	30000			
3						

- Enter the cells entries exactly the way they are in the worksheet.

If you are using cells range that is different from mine, make sure that you use the cell argument accordingly.

- To calculate the total, type **=Sum (A2:C2)** and press **Enter Key** or click **Enter**  **icon** on the formula bar.
- To calculate the average, type **=Average (A2:C2)** and press **Enter Key** or click **Enter**  **icon** on the formula bar.

Practice 2

Required: Calculate gross and tax. Tax is given as 5% of basic salary.

	A	B	C	D	E	F	G
1							
2							
3			Basic Salary	Allowance	Gross	Tax	
4			300000	15000			
5							

- To calculate gross, type **=C4+D4** and press **Enter key**.
- To calculate tax, type **=C4*5%** and press **Enter key**.

3.4.3 AutoSum Command

It is used to sum up numbers in a row or column automatically without imputing the formula by yourself.

Practice 3

How to use the Auto Sum

Type the following data

	A	B	C	D
1				
2		Lagos	500,000	
3		Ibadan	100,000	
4		Kano	70,000	
5		Benue	300,000	
6		Total		
7				

Place the cursor in the cell where you want your answer to be, and then click **AutoSum**  icon on the Standard tools bar



The **formula** that you suppose to type will appear on the formula bar

Also, you will notice a **wavy selection** round the range of cells

Press **Enter Key** or click **Enter**  icon on the **formula bar**.

	A	B	C	D
1				
2		Lagos	500,000	
3		Ibadan	100,000	
4		Kano	70,000	
5		Benue	300,000	
6		Total	=SUM(C2:C5)	
7				
8				
9				

SUM(number1, [number2], ...)

- Click on the “**AUTO SUM**” function  on the standard toolbar
- Click on the  icon Enter button or press Enter Key

Note: If you double click the **AUTO SUM** button, the sum value of the area in question will be computed automatically.

3.5 Functions

Microsoft Excel provides many other statistical and engineering worksheet functions that are of immense assistance when doing calculation of any sort. However explanation is given to few that relates to our course.

Integer Function: This function truncates the decimal part of a numeric entry and returns only the integer part. It does not approximate to the nearest whole number. It simply chops off the decimal part.

Round Function: This function approximates a numeric entry to the number of decimal place specified in the function argument, i.e. suppose cell B4 has entry 34.4772 and you want to round it to 2 decimal places, you will just type =Round(B4,2); and press Enter key to get 34.48 as the answer.

If Function: It returns one value if a condition you specify evaluates to **true** and another value if evaluates to **false**

Practice 4

How to round up and find Integers if Numbers

Calculate the integer and round functions of the following entries. The decimal places (d.p) to round up to is 2

	A	B	C
1	Number	Integer	Round (2 d.p.)
2	14.554		
3	726.896		
4	25.3476		
5	8.576		
6	92.314		
7	772.4513		
8	6.4		
9	5012.668		
10			

To calculate the integer of the first number, place the cursor in cell **B2** and type **=Int(A2)**

Press **Enter Key** or click **Enter**  icon on the **formula bar**.

To calculate the round function of the first number to 2 decimal places, place the cursor in cell **C2** and type **=Round(A2,2)**

Press **Enter Key** or click **Enter**  icon on the **formula bar**

	A	B	C	D
1	Number	Integer	Round (2 d.p.)	
2	14.554	14	14.55	
3	726.896			
4	25.3476			
5	8.576			
6	92.314			
7	772.4513			
8	6.4			
9	5012.668			
10				

After gotten the answer to the first number, **place the cursor back in the cel** that contains the answer, then **click**, **hold the fill handle** and drag to extend the formula to the adjacent below.

Please do no waist your time by calculating for each number.

Note: Supposing you were to round up to **3 decimal places** in the round function above, then you will type **=Round(A2,3)**.

If Function: Emphasis is laid on the **If Function** because of its importance in analyzing logical test.

If you are not practicing with your **Excel Tutor** document, please load it to enable us do our practical exercise with JSS 1 (Sheet 1) database in **Excel Tutor**.

Let us extend our field's headings to **Total**, **Average** and **Remarks** as shown below:

Practice 5**Required:**

1. Calculate the **total** and **average**, using any suitable Excel formula.
2. Remarks should show **Pass** for those students whose average is **greater than or equal to 50**, and **Fail** for those whose average is **less than 50**.

Hint: Carry out whatever calculation you intend to do with any record in the database, and then use the handfill to extend your formula to the others. However, it is suggested that you should practice with the first record so that you can easily use the handfill to drag down and extend the formula to other records below.

Note: Your database records are more than what you are seeing here.

	A	B	C	D	E	F	G	H	I	J	K
1	SKY LIMIT SECONDARY SCHOOL										
2	IGBOBI ROAD, YABA, LAGOS										
3	FIRST TERM EXAMINATION										
4	SURNAME	FIRST NAME	MIDDLE NAME	ENG. LANGUAGE	MATHEMATICS	INTRO TECH	SOCIAL STUDIES	HOME ECONS	TOTAL	AVERAGE	REMARKS
5	ADADU	PIUS	JAMES	39	58	36	24	46	203	40.6	Fail
6	ADEBAYO	AARON	ANDREW	28	49	33	72	28			
7	ASHIRU	DAHATU	ISAH	46	46	49	56	57			
8	BELLO	SARAH	BIOLA	81	67	39	48	47			
9	EGIEGBA	PAUL	UDO	49	78	72	45	46			
10	IYERE	JOHN	SOLOMON	48	49	44	47	57			
11	JACKSON	TITILAYO	SAMUEL	62	43	72	58	75			
12	MENSA	AMENKWE		48	65	74	58	24			
13	NIJOKI	CAIISTA	FRERE	47	78	53	58	87			

- To calculate **total**, place the cursor in cell **I5** and type **=sum(d5:g5)** and press **Enter key** or click **Enter** icon on the **formula bar**. You can also use the **AutoSum command** here.
- To calculate the Average, place the cursor in cell **J5** and type **=Average (d5:g5)** and press **Enter key** or click **Enter** icon on the **formula bar**
- To calculate the Remarks, place the cursor in cell **K5** and type **=if(j5 >= 50, "Pass", "Fail")** and press **Enter key** or click **Enter** icon on the **formula bar**.

Note: The IF Function is a logical test expression which you use to instruct the computer to give remarks as **Pass** to the student whose average in cell J5 is greater **than or equal to 50**; otherwise the computer should output **Fail** as remarks.

In the formula, **Pass** and **Fail** are in **double quote** because the computer has to output them directly. Anything you want to get back as you entered it in a formula must be in double quote. Please do not type single quote twice to mean double quote. They are not the same. Hold the Shift key to type double quote.

For the **brackets** in a logical formula – count the number of times the open bracket was applied, and close the formula with the same number. From the example above, open bracket was used twice, therefore the formula was closed with two. Please do not use **square bracket** [].

Please apply **Commas (,)** instead of space (gap) as indicated in the above formula. Remember that there is no space in between the characters of a formula.

Nested If Function: When you specify **more than 2 (Two) IF Logical Test Function**, it is then known as nested IF Function. The following example will give a clear picture of **Nested If Function**. The Grades: A, B, C, D E, F, were derived by using the **Nested If Function** as revealed on the **Formula Bar**.

	A	B	C	D	E	F	G	H	I
1	NAME	Mat. Number	1st Ass	2nd Ass	Exam	Total	Grade		
2	Tedy Ese	Sc/03/456	3	14	36	53	C		
3	Isaih Jomo	Sc/03/478	7	8	45	60			
4	Ade deji Tajudeen	Sc/03/325	6	2	48	56			
5	Edidiong Akpan	Sc/03/245	4	3	27	34			
6	Idemudia James	Sc/03/325	8	9	36	53			
7	Babatunde Sunday	Sc/03/132	10	12	42	64			
8	Okpokpo Jacinta	Sc/03/134	12	11	35	58			
9	Bramah Yakubu	Sc/03/327	5	12	30	47			
10	Zachaeus Sabina	Sc/03/246	4	6	50	60			
11	Iyoha Mary	Sc/03/252	13	14	60	87			
12	Taka Wence	Sc/03/191	12	9	29	50			
13	Yahaya Madaiki	Sc/03/122	11	10	23	44			
14	Manuzo Bamidele	Sc/03/212	11	7	22	40			
15	Olofin Paul	Sc/03/333	12	8	42	62			
16	Ayodele Oluwole	Sc/03/421	6	7	30	43			
17	Hassan Malik	Sc/03/315	12	5	43	60			

Practice 6**Question**

A colleague of yours doubts the benefits you will derive from EDA 183. Prove to him using the above database to let him know how he can reduce or eliminate the problems of errors, fatigue etc, he always faces in calculating his student's records in order to arrive at grades A, B, C, D, E, and F; that all he needs to do, is to calculate any of the student's grade and extend it to others within some minutes.

(Dept. of Educational Admin, University of Lagos, MIS, EDA 813 2002 / 2003 Session).

***Hint:** Know that the normal way of calculating grades is 70-100 A; 60-69 B; 50-59 C; 45-49 D; 40-44 E and 39 below F. The nested IF function is the best function to apply since there is need for multiple outcome of the function.*

How to use the Nested IF Function to calculate the grades in the database.

Place the cursor in the cell where you want the first value to appear – in this case, **cell G2**.

Type the formula like this:

```
=IF(F2>=70,"A",IF(F2>=60,"B",IF(F2>=50,"C",IF(F2>=45,"D",IF(F2>=40,"E",IF(F2<40,"F"))))))
```

Press **Enter key** or click **Enter**  **icon** on the **formula bar**.

Note: Try to edit the formula through the **formula bar** in case any mistake is made

3.6 Filtering a Database

Most often, a database occupies several rows of records that cut across so many pages of the worksheet; therefore there are always difficulties in searching for a particular record or group of records.

Filtering a database is a way of systematically searching for records that the specific criteria set meet.

Filtration of a database using the **AutoFilter** or **Custom filter** will reveal all records that match the set criteria at a glance.

Practice 7**How to use the AutoFilter**

For the practice of filtering a database, we shall create a **database** like the one below for Faculty of Education, XYZ University. You are free to create it in any sheet of your choice.

APPLICATION OF MANAGEMENT INFORMATION SYSTEM (MIS) IN EDUCATION

	<u>I.D. Number</u>	<u>Date of Birth</u>	<u>Sex</u>	<u>State</u>	<u>Local Govt</u>	<u>Address</u>	<u>Marital status</u>	<u>Dept</u>
Raymond	345	06-Apr-76	M	Lagos	Epe	10, Alade Street	Single	Adult
Henry	567	07-Jan-70	M	Oyo	Ibadan West	23, Apata Street	Single	Current
Trick	743	09-Dec-72	M	Ogun	Iju	12th Lane Adegun Estate	Married	Educ
oyis	645	01-Feb-74	M	Edo	Oredo	103, Akpapkava road	Single	PHE
u Silas	257	02-Nov-68	M	Kaduna	Samaru	56, Kufena Road	Married	Current
e Philip 281		04-Mar-69	M	Lagos	Oshodi	38, Damode Lane	Married	Adult
Jumai	423	05-Oct-75	F	Kano	Sabo Garri	7, Aminu Road	Married	PHE
s Odion 524		05-Aug-80	F	Edo	Esan West	92, Campus Street	Single	Educ
Idio	624	07-Jun-68	M	Akwa Ibom	Esien Udim	49, Uyo Road	Married	Current
omfort 341		08-Jul-70	F	Akwa Ibom	Uyo	87, Ekpenyong Street	Married	Adult
Ekeleku 262		11-Mar-81	M	Cross River	Calabar	Gold Staff Quarters	Married	PHE
ra Saliu 422		10-Apr-67	M	Kano	Chalawa	Kabuga Quarters	Single	Current
henane 622		10-May-80	F	Edo	Estako East	13, Polythecnic Rd. Auch	Married	Current
abakir	138	06-Feb-68	M	Kaduna	Zaria North	14, A.B. Way Samaru	Single	Educ
om	124	12-Apr-71	M	Benue	Gboko	17, J.S. Tarka way	Married	Adult
Ayodeji 625		07-May-82	M	Lagos	Oshodi	12, Audu Street	Married	Adult
jiro 336		06-Dec-75	F	Delta	Effurun	106, P.T.I. Road	Single	Educ

1
8
8

on any database you want to apply the AutoFilter to.

Step 1 of 2 Activate the **Data menu** to get a pull down of options from the menu.

Step 2 of 2 From the options that pop up, locate **Filter** and click on **AutoFilter**.

Look at the Fields Headings now. What do you observe? There is a **down facing arrow** at the **right hand side of each and every Field's Heading of the database**

	A	B	C	D	E	F
1	Names	I.D. Number	Date of birth	Sex	State	Local Govt
2	Magnus Raymond	345	06-Apr-76	M	Lagos	Epe
3	Jimoh Henry	567	07-Jan-70	M	Oyo	Ibadan West
4	Niyi Patrick	743	09-Dec-72	M	Ogun	Iju
5	Bello Sroyis	645	01-Feb-74	M	Edo	Oredo
6	Mamadu Silas	257	02-Nov-68	M	Kaduna	Samaru
7	Olatunde Philip	281	04-Mar-69	M	Lagos	Oshodi
8	Yahaya Jumai	423	05-Oct-75	F	Kanu	Sabo Garri
9	Zachaeus Odion	524	05-Aug-80	F	Edo	Ishau west
10	Nisikak Idio	624	07-Jun-68	M	Akwa Ibom	Esien Udim
11	Akpan Comfort	341	08-Jul-70	F	Akwa Ibom	Uyo
12	Edidiong Ekeleku	262	11-Mar-81	M	Cross River	Calabar
13	Mainasara Saliu	422	10-Apr-67	M	Kano	Chalawa
14	Ekpe Oghenane	622	10-May-80	F	Edo	Estako East
15	Bala Abubakir	138	06-Feb-68	M	Kaduna	Zaria North

Nature of the database after applying **Autofilter** **Down facing arrows** by the side of the fields' headings for Filtration.

Practice 8

How to filter a Database to get One Record

Let us assume for instance that you are asked to bring out **Comfort Akpan's information**.

You can use any of the **Fields Headings** to get her record, but use **NAMES** since her name is known

- Click on the **down facing arrow** by **NAMES field heading**

*You will notice a **pull down menus** of all the names in the **database***

- Click on any **name** you want to view its **record**. In this case **Comfort Akpan** is chosen.

Her record will show like the one below:

	A	B	C	D	E	F
1	Names	I.D. Number	Date of birth	Sex	State	Local Govt
11	Akpan Comfort	341	08-Jul-70	F	Akwa Ibom	Uyo
19						
20						

Position of the database after filtration

Practice 9

How to regain the whole Database after Filtration

- Click the **down facing arrow** by the side of the **field's heading** used for that particular filtration

	A	B	C	D	E	F
1	Names	I.D. Number	Date of birth	Sex	State	Local Govt
11	(All)	341	08-Jul-70	F	Akwa Ibom	Uyo
19	(Top 10...)					
25	(Custom...)					

- > Click on the **All** option.

Practice 10

How to view Records sharing Common Elements

For example, let us reveal staffs that are from Edo state.

Click on the **down facing arrow** by the side of **State** i.e. column E, and then click **Edo**.

	A	B	C	D	E
1	Names	I.D. Number	Date of birth	Sex	State
5	Bello Sroyis	645	01-Feb-74	M	Edo
9	Zachaeus Odion	524	05-Aug-80	F	Edo
14	Ekpe Oghenane	622	10-May-80	F	Edo
19					

Filtered Database to reveal staff from Edo state

3.6.1 Custom AutoFilter

Custom AutoFilter is used to set more complex criteria. Criteria such as: **equal to**, **greater than**, **less than** etc could be assigned to a numeric field (a field that is made up of a numeric digit); and criteria such as **begins with**, **ends with**, **does not begin with**, **contains** etc could be applied to a Text field. There is room to specify more than one criterion; also, wild cards could be used to set criteria here.

Practice 11

How to use Custom AutoFilter

We shall use **Excel Tutor document** you have created for this exercise, therefore open it to practice with it.

Let us assume that you are asked to search for those students whose averages are less than (<) 50 or greater than (>) 60

- Ensure that the **cursor is in any cell of the database.**
- Activate the **Data menu.**
- Locate **Filter** and click on **AutoFilter.**

SKY LIMIT SECONDARY SCHOOL											
IGBOBI ROAD, YABA, LAGOS											
FIRST TERM EXAMINATION											
	SURNAME	FIRST NAME	MIDDLE NAME	ENGLANGUAGE	MATHEMATICS	INTRO TECH	SOCIAL STUDIES	HOME ECONS	TOTAL	AVERAGE	REMARKS
5	ADADU	PIUS	JAMES	39	58	36	24	46	203	40.6	Fail
6	ADEBAYO	AARON	ANDREW	28	49	33	72	28	210	42	Fail
7	ASHIRU	DAHATU	ISAH	46	46	49	56	57	254	50.8	Pass
8	BELLO	SARAH	BIOLA	81	67	39	48	47	282	56.4	Pass
9	EGIEGBA	PAUL	UDO	49	78	72	45	46	290	58	Pass
10	IYERE	JOHN	SOLOMON	48	49	44	47	57	245	49	Fail
11	JACKSON	TITILAYO	SAMUEL	62	43	72	58	75	310	62	Pass
12	MENSA	AMENKWEE		48	65	74	58	24	269	53.8	Pass
13	NIJOKI	CAUSTA	FRERE	47	78	53	58	87	323	64.6	Pass

- Click on the down facing **arrow by the side of the field in question – Average** in this case.
- From the pull down menu, select **Custom**

The following Custom AutoFilter dialog box will appear

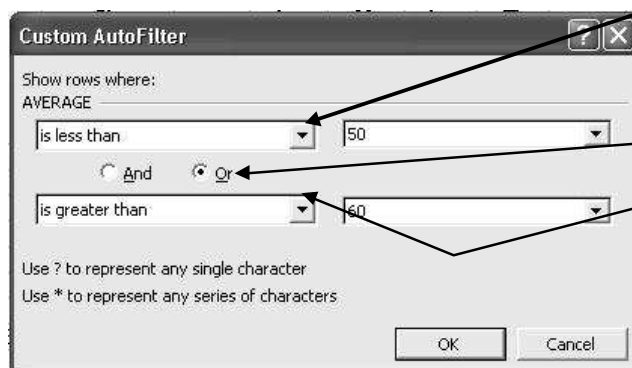

- Click on the **down facing arrow** to select the first relational operator (is less than) and type the **criteria 50**
- Click on **Or** in order to set second criteria
- Click on the **down facing arrow** to select the second relational operator (is greater than) and type the criteria 60
- Click on **OK** when you are through.

	A	B	C	D	E	F	G	H	I	J	K
	SURNAME	FIRST NAME	MIDDLE NAME	ENG. LANGUAGE	MATHEMATICS	INTRO TECH	SOCIAL STUDIES	HOME ECONS	TOTAL	AVERAGE	REMARKS
4											
5	ADADU	PIUS	JAMES	39	58	36	24	46	203	40.6	Fail
6	ADEBAYO	AARON	ANDREW	28	49	33	72	28	210	42	Fail
10	IYERE	JOHN	SOLOMON	48	49	44	47	57	245	49	Fail
11	JACKSON	TITILAYO	SAMUEL	62	43	72	58	75	310	62	Pass
13	NJOKU	CALISTA	EBERE	47	78	53	58	87	323	64.6	Pass
15	OKAFOR	VIVIAN	ADA	54	84	67	57	57	319	63.8	Pass
16	OKAFOR	FRANK		47	45	28	76	47	243	48.6	Fail
17	OKAFOR	CHIAMAKA	CECELIA	54	58	49	35	24	220	44	Fail
19	PETER	BASSEY	EDIDIONG	82	59	39	75	56	311	62.2	Pass
21	TOCHUKWU	EZE		45	47	84	23	25	224	44.8	Fail
22	TOPE	OMLARA	MUYIBAT	47	38	50	54	12	201	40.2	Fail

Result of the Database revealing students whose averages are below 50 or above 60.

3.6.2 Wild Cards

Wild Cards are the **Asterisk (*)** and the **Question mark (?)**. They are used to set criteria in situation where you want to use characters alone as criteria especially when the information about the particular record you want to search out is vague. * is used for **multiple character** selection, while? is used for **single character** selection.

Practice 12

How to use asterisk (*) and question mark (?) to set criteria

*You are required to search for staff whose **names** start with **letter (character) M** and **other character** could be anything.*

- Click the **down facing arrow** by the side of the **field's heading** – in this case, NAMES and click on **Custom**.

The Custom AutoFilter dialog such as the one below will come out.

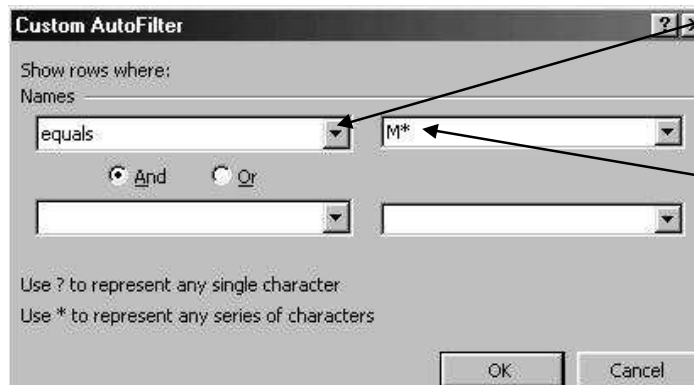

Click on the **down facing arrow** to select the relational operator base on the criteria you will set. Type the **criteria M***. This means that the first character must be M and others could be any character. Click on **OK** when you are through.

	A	B	C	D	E
1	Names	I.D. Number	Date of birth	Sex	State
2	Magnus Raymond	345	06-Apr-76	M	Lagos
6	Mamadu Silas	257	02-Nov-68	M	Kaduna
13	Mainasara Saliu	422	10-Apr-67	M	Kano
19					

Result of the Database revealing staff whose names start with character (letter) M

Practice 13

How to use question mark (?) to set criteria

You are required to search for staff who are from 5 letters (5 characters) state.

- Click the **down facing arrow** by the side of the **field heading** – in this case, STATE and click on custom.

The Custom AutoFilter dialog such as the one below will come out.

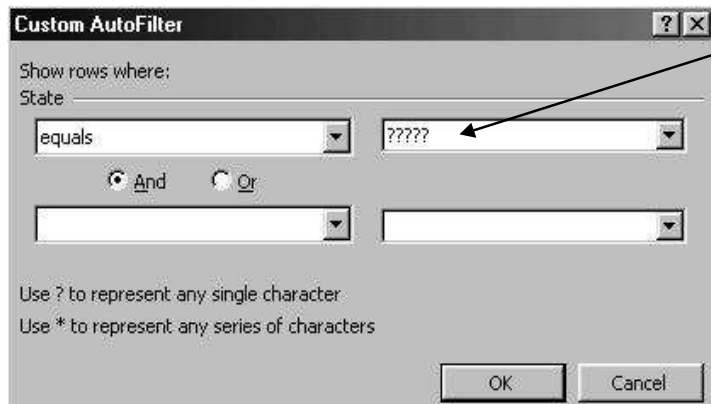

Type the **criteria** ????? This means that any state that is 5 characters will come out. Click on **OK** when you are through.

	A	B	C	D	E
1	Names	I.D. Number	Date of birth	Sex	State
2	Magnus Raymond	345	06-Apr-76	M	Lagos
7	Olatunde Philip	281	04-Mar-69	M	Lagos
16	Aloy Ihom	124	12-Apr-71	M	Benue
17	Olawole Ayodeji	625	07-May-82	M	Lagos
18	Aziza Ejiro	336	06-Dec-75	F	Delta
19					

Result of the Database revealing states with 5 characters

Practice 14

How to Remove the Arrows by the Side of the Fields' Headings caused by the Auto filter.

- Position the cursor in any of the cells.
- Activate the **data menu**.
- Locate **filter** and uncheck **AutoFilter**.

3.7 Printing

There is no much difference between Word Printing and Excel Printing. The only area where there is slight difference is: page layout and margins. And you must **print preview** of the worksheet in order to see how the document is before printing.

Practice 15

How to Print Preview

- Open the **document (Excel Tutor)** and click to ensure that the **cursor** is in any of the cells that contain the data.
- Activate the **File menu** and click on **Print Preview** or click on

Print Preview icon  on the **Standard tools bar**

The Print Preview window such as the one below will open

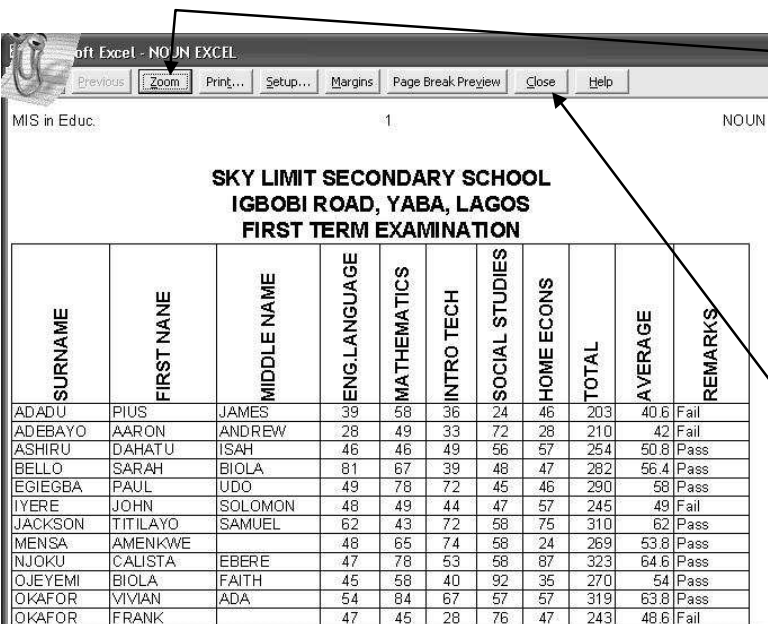

Click on the **Zoom button** to zoom to see details of the previewed page

Click on the **close button** to close Preview window

SURNAME	FIRST NAME	MIDDLE NAME	ENG. LANGUAGE	MATHEMATICS	INTRO TECH	SOCIAL STUDIES	HOME ECONS	TOTAL	AVERAGE	REMARKS
ADADU	PIUS	JAMES	39	58	36	24	46	203	40.6	Fail
ADEBAYO	AARON	ANDREW	28	49	33	72	28	210	42	Fail
ASHIRU	DAHATU	ISAH	46	46	49	56	57	254	50.8	Pass
BELLO	SARAH	BIOLA	81	67	39	48	47	282	56.4	Pass
EGIEGBA	PAUL	UDO	49	78	72	45	46	290	58	Pass
IYERE	JOHN	SOLOMON	48	49	44	47	57	245	49	Fail
JACKSON	TITILAYO	SAMUEL	62	43	72	58	75	310	62	Pass
MENSA	AMENKWE		48	65	74	58	24	269	53.8	Pass
NJOKU	CALISTA	EBERE	47	78	53	58	87	323	64.6	Pass
OJEYEMI	BIOLA	FAITH	45	58	40	92	35	270	54	Pass
OKAFOR	VIVIAN	ADA	54	84	67	57	57	319	63.8	Pass
OKAFOR	FRANK		47	45	28	76	47	243	48.6	Fail

After you have printed Preview and returned to the document, you will notice some horizontal and vertical dotted lines. These lines indicate the margins of each page – left/right and top / bottom. If you are not in agreement with the outcome of the Print Preview, click on **Page Setup** from the **File menu** in order to set the margins.

Practice 16

How to print a document

- Open the **document** e.g. (**Excel Tutor**) and click to ensure that the cursor is inside the document.
- Activate the **File menu** and click on **Print** or press **Ctrl + P** on the keyboard. Please do not use the **Print icon**  on the **Standard tools bar** at first printing because it will not give you the print dialog box for printing set-up

The Print dialog box like the one below will appear

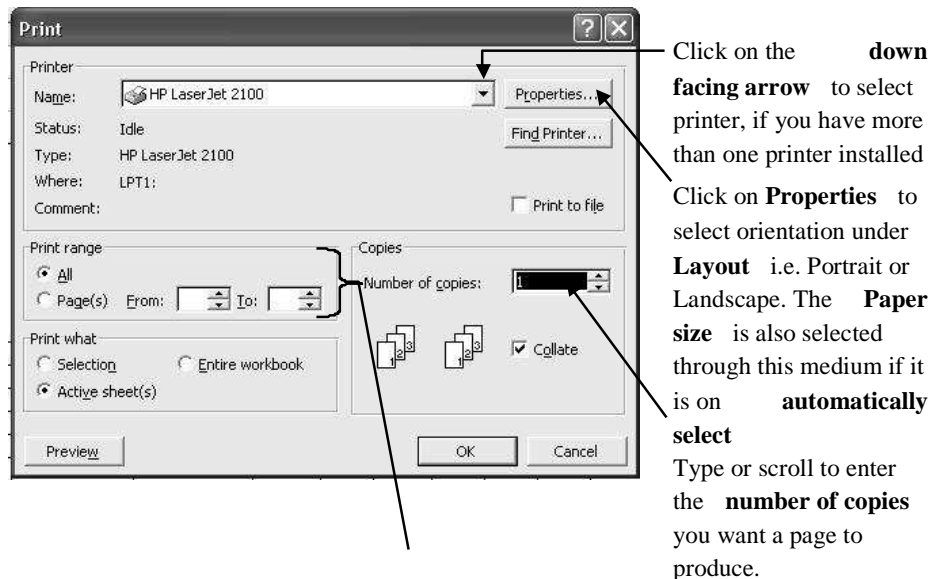

In **Print range section**, select **All** - for all the pages to be printed; select **Pages** if you want to type the particular page number which should be printed first in the edited box of **From** and the last page in the edited box of **To**. You can repeat the same page number, if you want to print out only that page e.g. **From 2 To 2**.

4.0 CONCLUSION

With excel formula and function, difficult and time wasting calculation could be done at ease and the result could be 100% correct. However remember the computer slogan “garbage in, garbage out”. If you coded wrong formula, the computer might give wrong answer or no answer at all.

5.0 SUMMARY

Excel formula must be preceded with the sign of equality (=) or plus (+) or at (@). And there should be no space in formula entries.

6.0 TUTOR-MARKED ASSIGNMENT

1. It happened that you maintained the records of about 700 students with spreadsheet management. One day, at the departmental meeting there was a kind of special concern about the mass failure of students offering your course. Subsequently, you were asked by the HOD to go and adjust the result by adding 5 marks to the total of those students who are less than or equal to 39.

Use the following sample to show how you gave them a big surprise by forwarding the adjusted result within 10 minutes while the meeting was still going on.

Note that you have to calculate the adjusted total and new grades.

	A	B	C	D	E	F	G	H	I
	MAT. NUMBER	NAMES	1ST ASS.	2ND ASS.	EXAM.	TOTAL	GRADES	ADJUSTED TOTAL	NEW GRADES
1									
2	Soc/02/4567	Idemudia Alice	4	3	37	44	E		
3	Soc/02/4567	Edidiong Paul	12	4	21	37	F		
4	Soc/02/4323	Olawole Janet	11	10	54	75	A		
5	Soc/02/4326	Ekeluke Ene	6	2	45	53	C		
6	Soc/02/4328	Babando Kadir	4	12	18	34	F		
7	Soc/02/4327	Al-Kasin Alemu	10	14	30	54	C		
8	Soc/02/4321	Dele Yinka	9	10	19	38	F		
9	Soc/02/4327	Raymond Ayasi	8	8	25	41	E		
10	Soc/02/4218	Lucky Lucy	12	6	10	28	F		
11	Soc/02/4215	Zacky Patrick	6	11	20	37	F		
12	Soc/02/4214	Olumide Pius	4	10	23	37	F		
13	Soc/02/4219	Abugu Benedict	4	4	50	58	C		
14	Soc/02/4216	Osuji John	12	7	20	39	F		
15	Soc/02/4221	Abu Mary	9	5	38	52	C		
16	Soc/02/4223	Salako Funsho	7	6	19	32	F		

(Dept. of Educational Admin, Faculty of Education, University of Lagos, MIS, EDA 813 2002 / 2003 Session).

Hint: according to the question, you are asked to add 5 marks to the Total of those who are Less than or equal to 39 and nothing to those who are 40 and above. All you need to do is to use the IF function to add the marks and then calculate the new grade based on the adjusted total as follows:

Place the cursor in cell H2 and type the formula for **the adjusted total**

```
=IF(F2<=39,F2+5,F2+0)
```

Also, place the cursor in cell **I2** to calculate the new grade with this

formula

```
=if(h2>=70,"A",if(h2>=60,"B",if(h2>=50,"C",if(h2>=45,"D",if(h2>=40,"E",if(h2<40,"F"))))))
```

You will notice that most of the students have passed now.

2. What are the functions of DBMS?

7.0 REFERENCES/FURTHER READINGS

French, C.S. (2000). *Computer Science*, Asfifor Colour Press: Gosport Hants, 5th Edition.

UNIT 5 MICROSOFT EXCEL CONTINUED CHARTS

CONTENTS

- 1.0 Introduction
- 2.0 Objectives
- 3.0 Main Content
 - 3.1 What is a Chart?
 - 3.2 Parts of a Chart
 - 3.3 Chart Selection
 - 3.4 Formatting Chart
- 4.0 Conclusion
- 5.0 Summary
- 6.0 Tutor-Marked Assignment
- 7.0 References/Further Readings

1.0 INTRODUCTION

This unit considers means of representing information in simple charts or graphs which are powerful means of disseminating information. With Microsoft Excel you can plot two-dimensional and three-dimensional charts types. In excel, you have standard and custom types of chart. Custom contains B&W (black and white) and other special charts in colour, in addition to types of charts that standard contains.

2.0 OBJECTIVES

At the end of this unit you should be able to:

- learn how to insert Chart
- identify the different parts of a Chart
- select Chart item or part
- format different parts of a Chart.

3.0 MAIN CONTENT

3.1 What is a Chart?

A chart is a graphical representation of work sheet data, which is also called graph.

Excel allows you to create a chart directly in a work sheet or as a separate document in its own window. Before you can create chart, you must first enter the data to be used to plot the chart in a worksheet.

Practice 1

How to create a Chart

We shall use only **pie** and **bar (column)** charts for illustrations. However try to plot many other chart types on your own, using the same information.

You have been asked by the administrator of River Side Grammar School to assist him to represent the following students' population information on a pie chart:

JSS 1 455; JSS 2 320; JSS 3 525; SSS 1 240; SSS 2 630; SSS3 150.

	A	B	C	D	E	F	G	H	I	
1	JSS 1	455	Enter the data either in column form or in row form as entered here.							
2	JSS 2	320								
3	JSS 3	525								
4	SSS 1	240								
5	SSS 2	630								
6	SSS 3	150			JSS 1	JSS 2	JSS 3	SSS 1	SSS 2	SSS 3
7					455	320	525	240	630	150
8										

Place the **cursor** in any of the **cells** that contain the data or Select the **range of cells** that contain the data.

- Activate the **Insert** menu and choose **Chart** or Click the **Chart Wizard** tool  on the **Standard Tools Bar**

A chart wizard dialog box will appear. The Chart Wizard guides you through the steps required to create a chart.

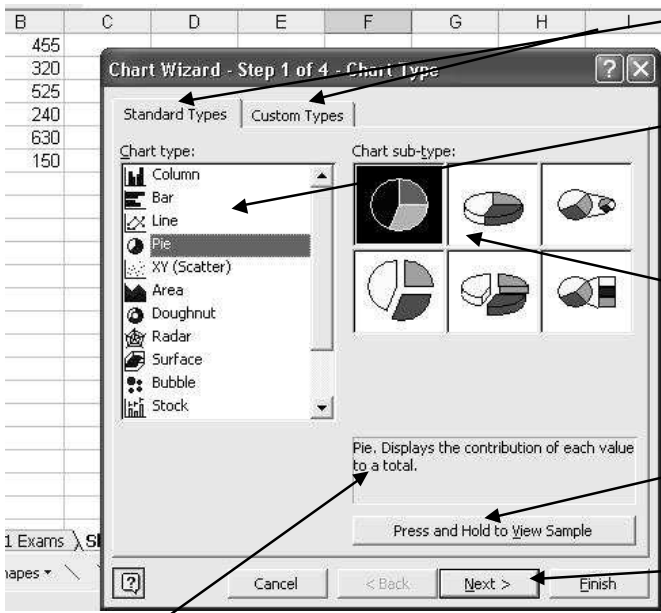

Click Standard Type tab or Custom Type tab

Select any **Chart Type** of your choice from the **Chart Type** category. In this case, Pie is selected

Select any **Chart sub-type** of your choice from the **Chart sub-type** category. In this case, the first Pie is selected

Press and hold the mouse to view the **sample of the chart sub-type** you have selected

Click on **Next** tab to go to the next step i.e. **step**

Pie. Displays the contribution of each value to a total.

Press and Hold to View Sample

Cancel < Back Next > Finish

Please always try to look at the **name** of any selected **chart sub-type** here.

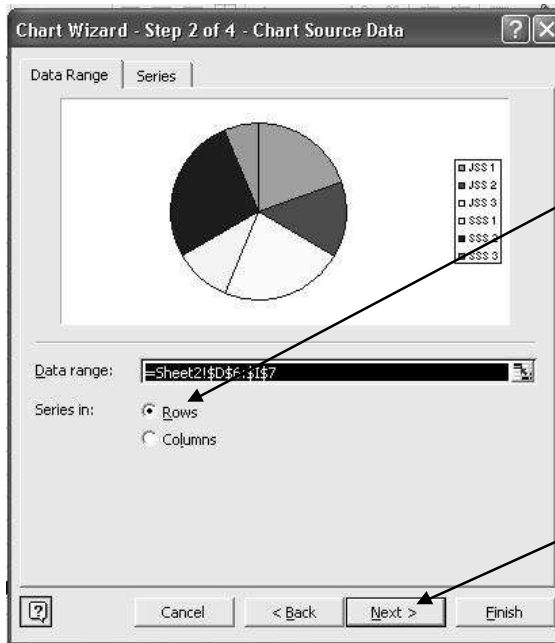

Step 2 shows you the **range and series** you are using. Please do not alter the **default selection**.

My **default selection** is on rows because I used the range of cells entries in rows. Yours will be in column if you entered your data in column form.

Click on **Next tab** to go to **step 3**

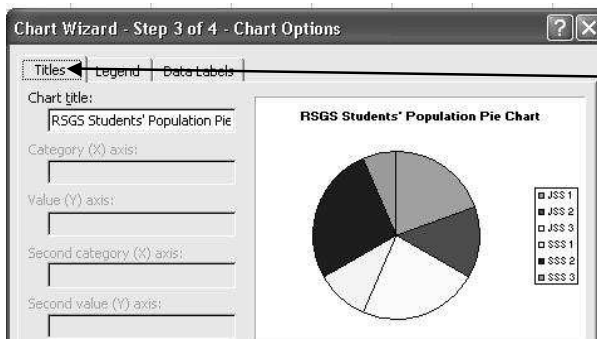

Click on **Title tab** in order to type the title. For example, **RSGS Students' Population Pie Chart** is typed as the title. Categories axis X and Y may be active when plotting other types of charts

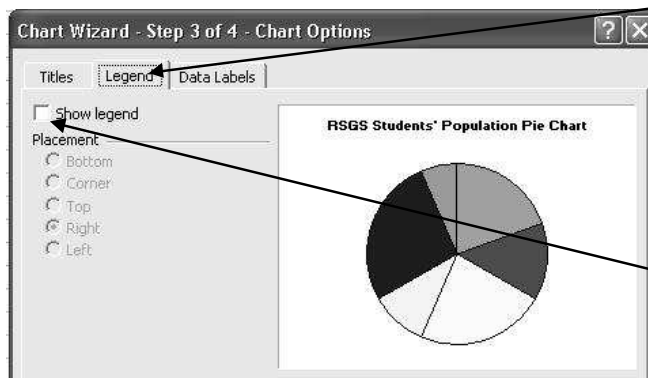

Click on **Legend tab** in order to reposition the legend. A legend is just like a key to a map. It shows what the chart is all about. Here, it is positioned by the right of the chart. Unchecked **show legend** in order to have more space for the chart, then, use data labels to depict what you want the pie sectors to reveal.

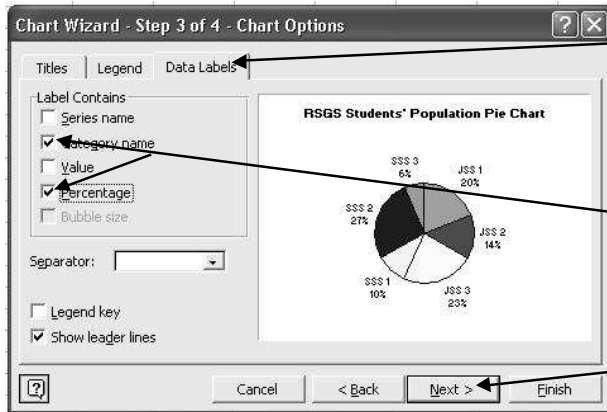

Click on **Data Labels** tab in order to give provide more information which the legend might not provide

I checked **category name** and **percentage** for the information of each sector name and percentage

Click on **Next** tab to go the final stage (Step 4).

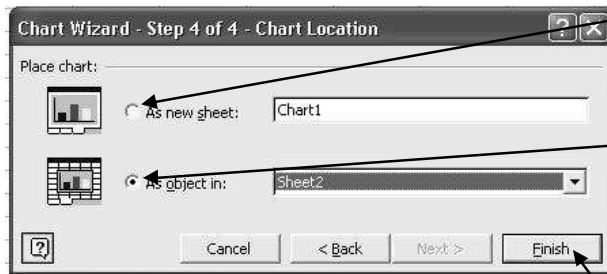

Click to select **As new sheet** option so that the chart will appear in its own sheet.

Click to select **As Object in** option so that the chart will appear in the sheet that contains the data you used to plot it.

Note: It is ideal that you plot the chart on a different sheet of its own, therefore choose the first option

Click on **Finish** tab to execute your action.

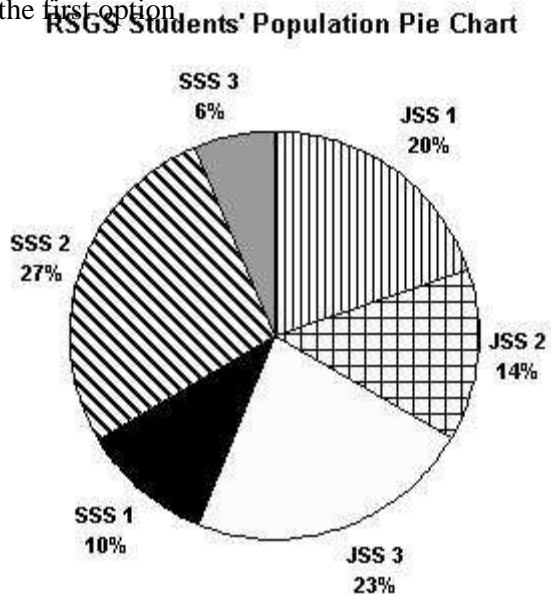

It will appear as chart 1 in a separate sheet in between the sheet tabs on the scroll bar

Practice 2

You are required to present with a Bar chart the population information of Palm Day Private Secondary School for the year 2001-2006. The data given are as follows:

	2001	2002	2003	2004	2005	2006
T. Staff	25	27	30	40	35	30
N. T. Staff	8	14	12	18	10	15
Students	75	100	120	80	150	115

- Enter the data in any **sheet**, **starting from any cell of your choice**, but do not jump any cell in between the range of cells.

Example of how to enter the data is shown below:

	D	E	F	G	H	I	J
		2001	2002	2003	2004	2005	2006
T. Staff		25	27	30	40	35	30
N.T. Staff		8	14	12	18	10	15
Students		75	100	120	150	130	115

- Select the **whole range** of **cells** that contain the data or place the **cursor** in any of the **cells** that contain the data
- Activate the **Insert** menu and choose **Chart** or Click the **Chart Wizard** tool  on the **Standard Tools Bar**

A chart wizard dialog box like the one in practice 1 will appear.

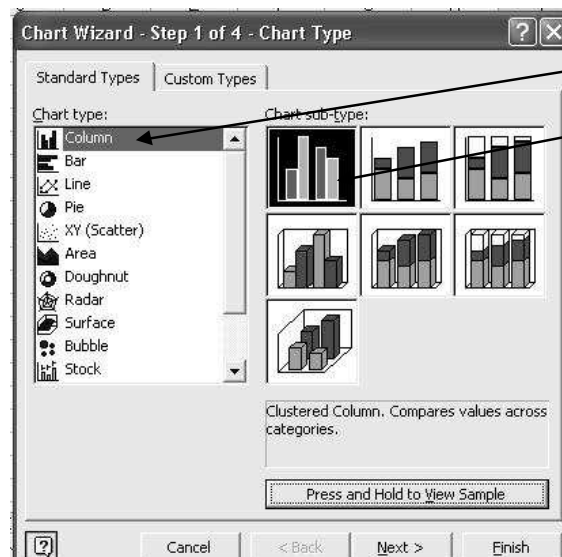

Column is selected under chart type and

Clustered Column is selected under Chart sub-type.

Click on **Next** to go to step 2

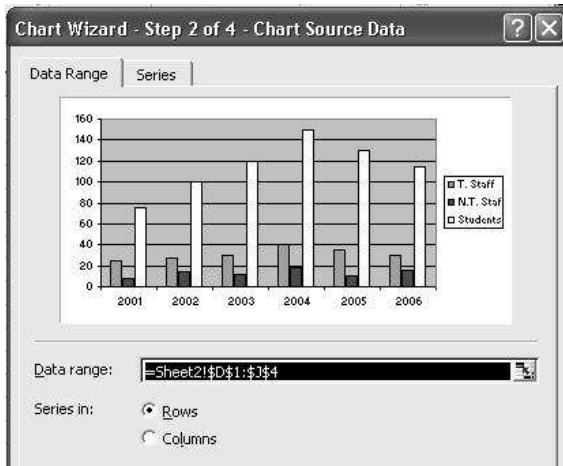

Step 2 reveals the **range** of the data you are using to plot the graph.

As said in practice 1 above, nothing is done here. Accept the **default selection**.

Click on **Next** to go to step 3

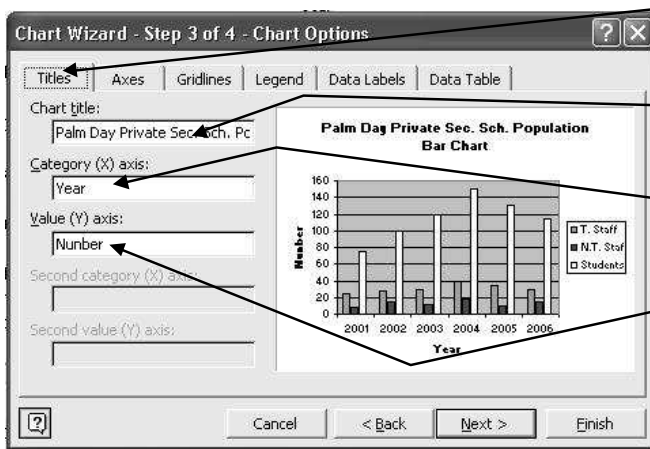

Click on **Title tab** so that you can enter all the necessary titles as follows

Click and type the chart title – **Palm Day Private Sec. Sch. Population Bar Chart**.

Click and type the title – **Year** for X-axis

Click and type the title – **Number** for Y-axis

Click on Next to go to the final stage – Step 4.

Note: you can give more information by using other tabs, but it is advisable not to load the chart with too much of information. You will notice that I did not use **data labels** here and **legend** is now left to give information with the colour of the bars.

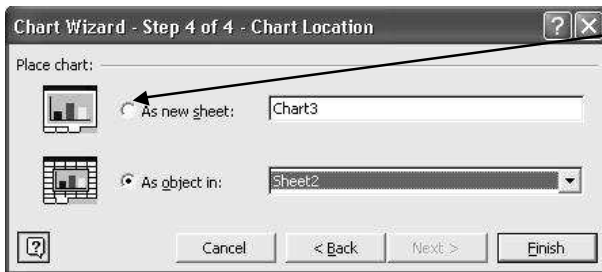

Click to select **As new sheet**.

Click on **Finish** to complete your action.

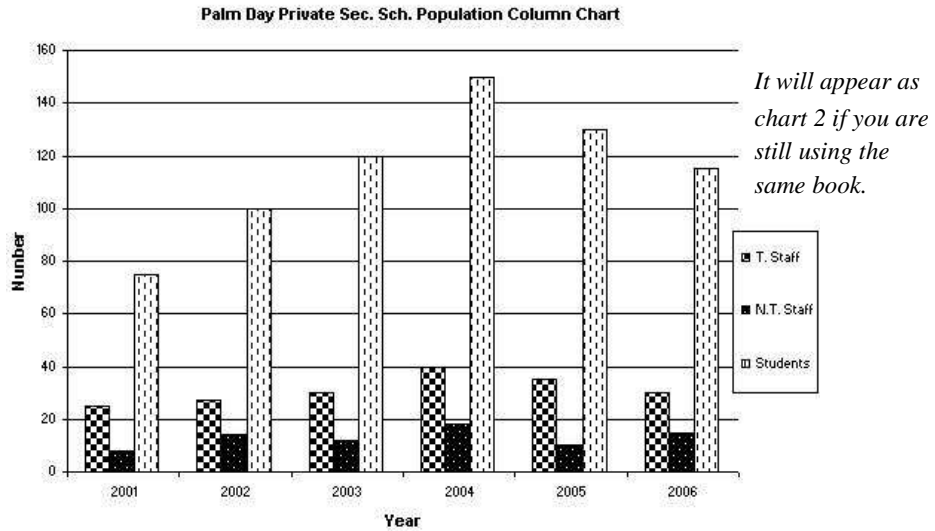

3.2 Parts of a Chart

A chart displays different parts peculiar to its type. For example, a column or bar chart will display parts as labeled on the chart below. Almost every chart has these parts.

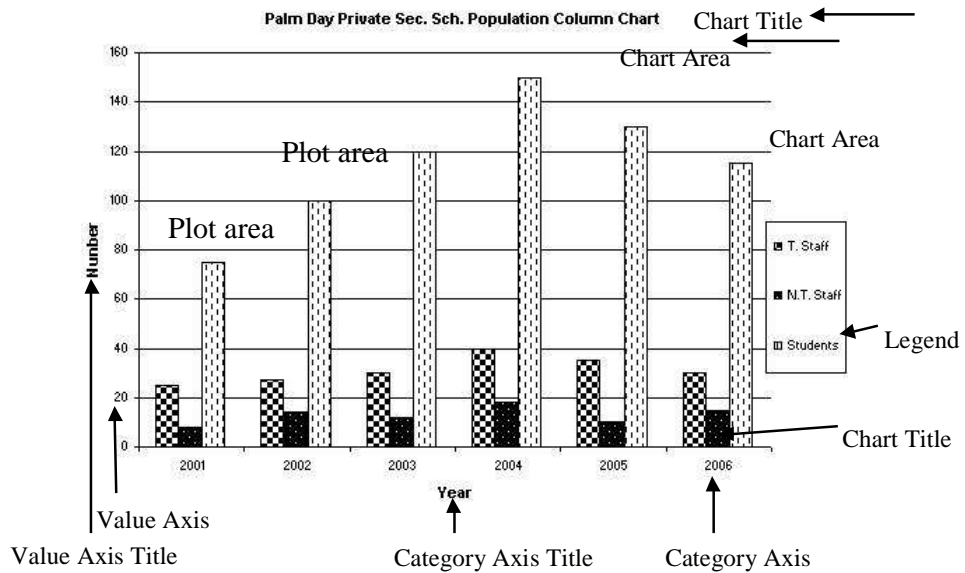

Please point to each labeled part for identification. The name will appear when you point at it.

3.3 Chart Selection

You must first select a chart item before you can format or edit it. If no chart item is selected, most of the format menu commands will be unavailable and the formatting bar will be blank.

Practice 3

How to select Part or Item of a Chart

- Click once on the **particular Item**. But if the parts are in series like the column chart above, click once to select the whole data series (N Staff, N T Staff and Students), then click once again to select a particular series e.g. N Staff.

3.4 Formatting Chart

Parts of a chart are formatted to give varieties of colour, font sizes, orientation etc. You may wonder that your chart is different from mine. Why? I formatted the sectors and bars of my charts to take pattern colour, since the output will be on black and white hard copy. I even removed the background of the second graph.

Note that you will get peculiar type of format dialog box based on whatever part of the chart or item you have selected. For instance the format dialog box that will appear when **plot area** is selected is quite different from the one that will appear when **chart title** is selected.

Practice 4

How to format different Parts of a Chart

- Click to select the particular **part** or **item** of the chart you want to format. Please click twice (not double clicking) to select the particular bar representing the series.
- Press **Ctrl + 1** on the keyboard

The format dialog box such as the one below will appear.

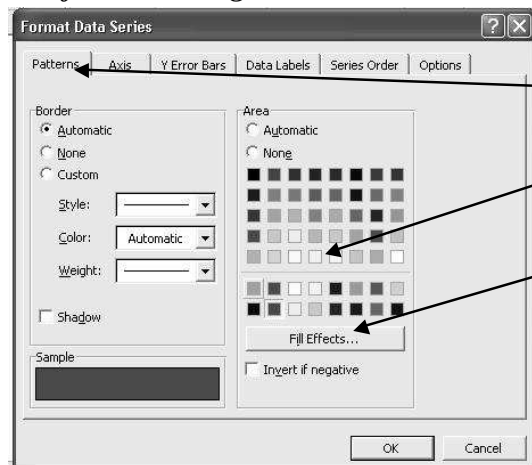

Click on **Pattern** tab if it is not already opened

Click on **any colour** of your choice to apply colour

Click on **Fill Effects** to apply pattern colour through the dialog box that will come up.

Example of such **Fill Effect dialog box** is shown below

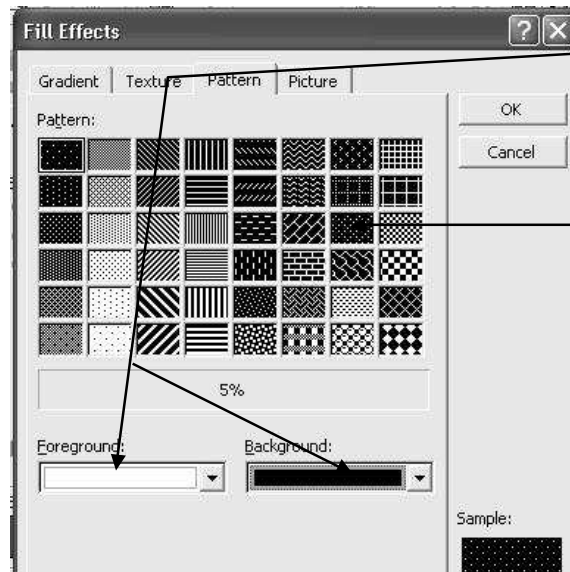

Change the **Foreground** and **Background** colours to the desired ones. In this case, Foreground is white while Background is black.

Click to select any **pattern colour**

Click on **OK** to carry out your formats.

Click on **OK** again on the cascaded Format Series Data dialog box.

Note: You can also use the following optional methods to get **format dialog** after selecting the chart part or item.

Optional method 1

Activate the format menu and click on **selected xxx** (**xxx** represents what ever part or item that is selected. For example, if **axis title** is selected, you will see **selected axis title**).

Optional method 2



Click on the **format xxx** **icon** on the **chart tools bar**. Please remember that **xxx** represents the name of the selected chart part. For instance, from the chart tools bar below, the name of the selected part is **Legend**



The Chart Tools Bar

The Chart Tool Bar normally comes out with the inserted chart. However, you can reveal it if is hidden with any method of how to reveal hidden tools bar.

Optional method 3

Double click on the **part** on the part you intend to format. Selection may not be needed when using this method.

Optional method 4

Right click on the **selected part** and then click **format xxx**

Please use any part e.g. chart title to see whether all the above options will give you the same dialog box. For example: Change default font size of **chart title** to 9.and color to Blue.

4.0 CONCLUSION

There are four steps to take to plot a Chart in Excel and at the final step, you have two options to choose from: As new sheet and As object in As a new sheet option will make the chart to appear in its own sheet. While As object in will make it to appear in the sheet that contains the data you use to plot it.

5.0 SUMMARY

Format dialog box of a chart comes up based on the part of the chart or items that was select

6.0 TUTOR-MARKED ASSIGNMENT

1.

Products	Jan/Feb	Mar/Apr	May/Jun	Jul/Aug	Sep/Oct	Nov/Dec
CPU	20000	10000	16500	10000	15000	1800
Monitor	15000	8000	19000	11000	20000	7000
Mouse	12000	18000	20000	17000	9000	15000
Keyboard	9000	15000	7000	19000	10300	12500

- i) Represent the data above on a column chart. Use the standard type
 - ii) Title should be Virgo Preadicanda Computers Bi-monthly Sales.
 - iii) Plot chart on a separate sheet.
 - iv) Format all columns (bars) colour to show black and white. Note that pattern colours should be used for the purpose of distinctiveness.
 - v) Show legend on the right hand side of the chart.
2. NOUN has the following number of students from the six major cities in Nigeria – Kano, Kaduna, Abuja, Port-Harcourt, Enugu and Lagos.

Given the data below:

Kano	45
Kaduna	28
Abuja	50
P. Harcourt	35
Enugu	20
Lagos	65

You are asked to plot:

- i) Standard type – lines with markers under chart Sub- type
- ii) Custom type – Cones.

Show cities names on the X- axis and prospective student's numbers on the Y-axis.

7.0 REFERENCES/FURTHER READINGS

French, C.S. (2000). *Computer Science*, Asfifor Colour Press: Gosport Hants, 5th Edition.

Petroleum Training Institute (PTI), (1999). *Lecture Manual on Spreadsheet Management*, Warri.