

Name:Class: Adm.No.

232/1
PHYSICS
THEORY
Paper 1
June 2022
 Time: 2 hours

Candidate's Signature:

KASSU JOINT EXAMINATION
JUNE 2022
Kenya Certificate of Secondary Education
PHYSICS
PAPER 1

Instructions to Candidates

- Write your name, admission number, class and signature in the spaces provided at the top of the page. This paper consists of two sections; **A** and **B**.
- Answer **ALL** the questions in the spaces provided.
- Mathematical tables and electronic calculator may be used.
- All working **MUST** be clearly shown.
- This paper consists of **11** printed pages.
- Candidates should answer the questions in English and check to ensure that no question(s) is missing.

FOR EXAMINER'S USE ONLY

SECTION	QUESTIONS	MAXIMUM SCORE	CANDIDATE'S SCORE
A	1 – 10	25	
B	11	10	
	12	11	
	13	13	
	14	09	
	15	07	
	16	05	
TOTAL SCORE		80	

SECTION A (25 MARKS)

Attempt all the questions in the spaces provided.

1. Define mechanics as used in Physics **(1 mark)**

.....

.....

2. The mass of an empty density bottle is 15g and 60g when full of oil of density 0.8gcm^{-3} . Determine volume of water that would fill the density bottle completely.

(3marks)

.....

.....

.....

.....

.....

3. Give the molecular explanation of surface tension **(2 marks)**

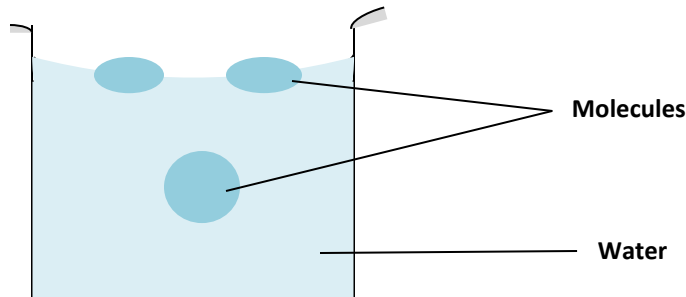

.....

.....

.....

4. The diagram below shows a flask with common salt and water. The adjacent diagram shows the same flask after it has been shaken and the salt has dissolved. State the purpose of experiment and explain what is observed. **(2 marks)**

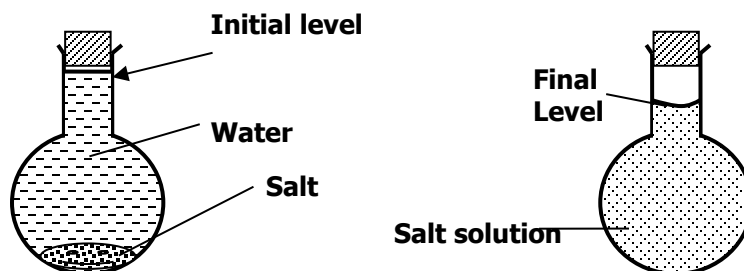

.....

b) A drop of milk when carefully put in a glass of water turns the water white after sometimes, explain this observation **(1mark)**

.....

5. The figure below shows two glasses of different thickness

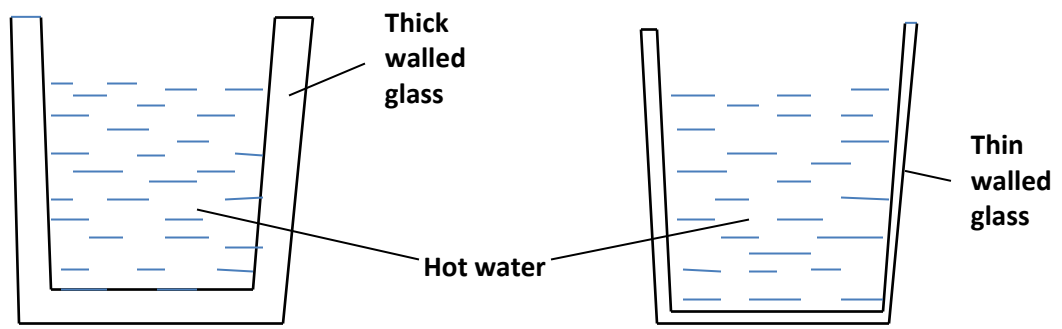

Hot water was poured in both glasses. State and explain what observed. **(2 marks)**

.....

6. The diagram below shows a heater immersed in water in a test tube coated with uniform layer of candle wax

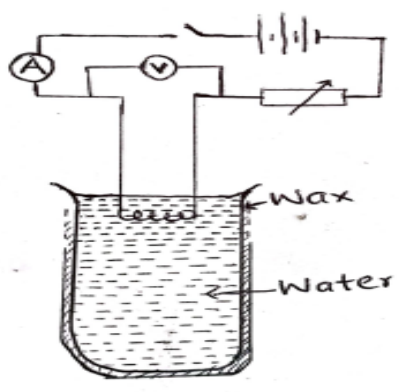

a) State and explain the observation after the switch is closed. **(2marks)**

.....

b) What observable changes would be made if water was replaced with mercury **(1mark)**

.....

7. State the conditions of equilibrium when the body is acted upon by a number of parallel forces **(2marks)**

.....

.....

.....

.....

8. The figure below shows two light sheets of paper arranged as shown.

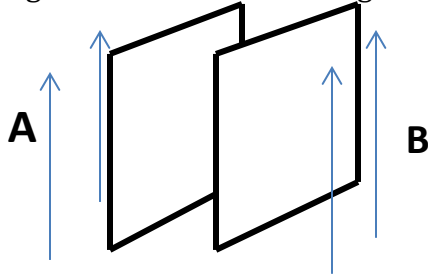

Explain the observation made when air is blown at the same speed at the same time at point A and B. **(2marks)**

.....

.....

.....

9. The figure below shows a graph of Force against extension of two springs made from different materials

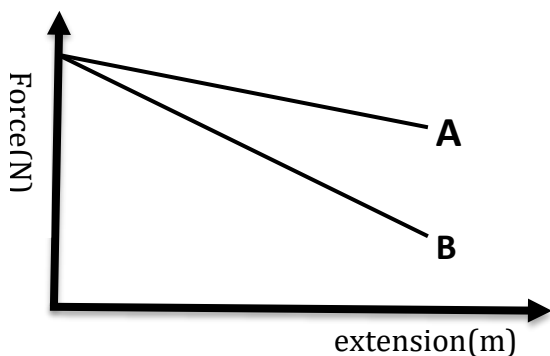

a) Compare the spring constants of the springs above **(1 mark)**

.....

.....

b) State two ways in which the spring constant can be increased **(2 marks)**

.....
.....

10. a) State Charles law for an ideal gas. **(1mark)**

.....
.....
.....

b) A gas has a volume of 20cm^3 at 27°C and normal atmospheric pressure. Calculate the new volume of the gas if it is heated to 54°C at the same pressure. **(3marks)**

.....
.....
.....
.....
.....
.....

SECTION B (55 MARKS)

Attempt all the questions in the spaces provided.

11. a) The figure below shows part of a scale of a vernier caliper with an error of +0.03cm. What is the actual reading? **(2 marks)**

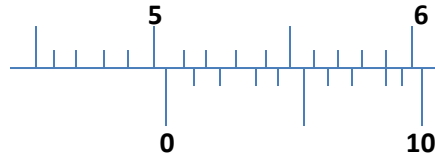

.....

- b) In an experiment to estimate the thickness of an oil drop of diameter 0.1cm spread onto a circular patch of diameter 10cm.

- i) Determine the volume of the oil drop **(2marks)**

.....

- ii) Calculate the area covered by the oil patch **(2marks)**

.....

- iii) Determine the thickness of the oil molecule **(2marks)**

.....

- iv) State **one** assumptions made in c(iii) above **(1mark)**

.....

- v) State **one** possible sources of errors in this experiment **(1mark)**

.....

12. a) State Pascal's Principle of transmission of pressure in liquids **(1mark)**

.....

b) The figure below shows an instrument used to measure atmospheric pressure. State with a reason the modification that would be required in a similar set-up if mercury was to be replaced with water. **(2marks)**

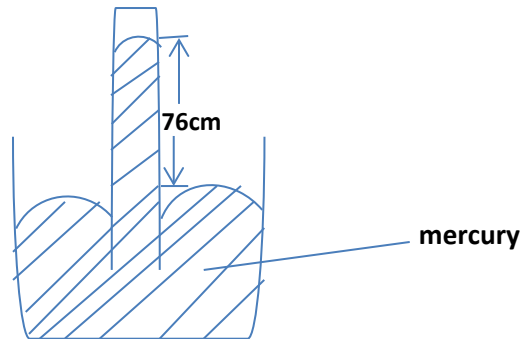

.....

.....

.....

c) The barometric height of a town is 640 mmHg. Given that the standard atmospheric pressure is 70 cmHg and density of mercury is 13.6 g cm^{-3} , determine the altitude of the town in metres (density of air = 1.3 kg m^{-3}). **(3marks)**

.....

.....

.....

.....

c) i) State two factors that affect the moment of a force. **(2marks)**

.....

.....

.....

ii) An aluminum beam 5.0 m long and whose mass is 200 g is suspended by a steel cable from a concrete beam and pivoted on a stool pole as shown below.

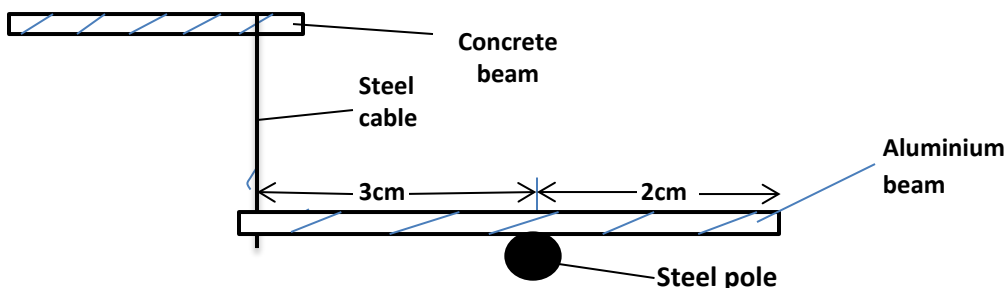

Calculate the tension T in the steel cable

(3marks)

.....

.....

.....

.....

.....

13. a) Define displacement and state its SI Unit

(2marks)

.....

.....

.....

b) A body is projected horizontally at a velocity of 120cms^{-1} from a cliff 90m tall

Draw a displacement–time graph to show the motion

(1mark)

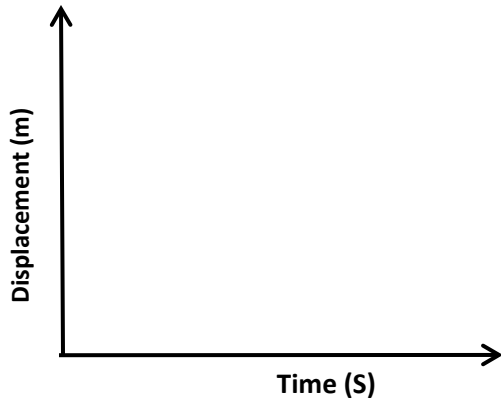

c) Calculate

i) The time taken to hit the ground

(2marks)

.....

.....

ii) The horizontal range.

(2marks)

.....

.....

.....

.....

.....

d) A stone is whirled with a uniform speed in horizontal circle having a radius of 12cm. It takes the stone 9seconds to describe an arc of length 6cm. Calculate:

I. The angular velocity **(2marks)**

.....
.....
.....

II. Linear velocity of the stone **(2marks)**

.....
.....
.....

III. Its periodic time T **(2marks)**

.....
.....
.....

14. (a) State Newton's 2nd Law of Motion **(1mark)**

.....
.....
.....

(b) A bus of mass 2000kg initially moving at 20ms⁻¹ is brought to rest over a distance of 40m. Determine the force required to achieve this. **(3marks)**

.....
.....
.....
.....
.....

(c) A mason uses six wheel pulley system to raise stones to a storey building for construction. He raises a weight of 3000N through a vertical height of 5m using the machine. If the mason pulls using an effort of 500N, calculate;

i) The velocity ratio of the pulley system. **(1 mark)**

.....
.....
.....

ii) The work done by the mason. (2 marks)

.....

.....

.....

iii) The useful work done by the pulley system. (2marks)

.....

.....

.....

15. (a) State two ways in which the melting point of a substances can be raised(2marks)

.....

.....

.....

(b)A 200g mass of ice at -20°C was slowly heated by an element heater of power 30W. The figure below shows the graph of temperature against time.

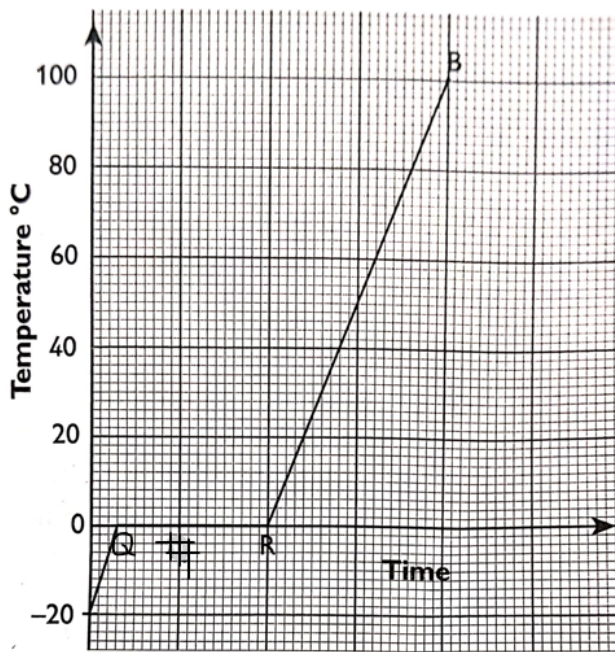

Use the values given below to calculate the time in minutes corresponding to;

i) The line QR in the graph (*specific latent heat of fusion is 357000Jkg^{-1}*) (3marks)

.....

.....

.....

ii) The line RB in the graph (*specific heat capacity of water is $4200\text{Jkg}^{-1}\text{k}^{-1}$*) **(1mark)**

.....
.....
.....

c) Calculate the specific heat capacity of ice **(1mark)**

.....
.....

16. a) State the law of floatation. **(1mark)**

.....
.....

b) A solid of mass 100g and density 2.5g/cm^3 weighs 0.5N when totally submerged in a liquid. Determine the density of the liquid. **(2marks)**

.....
.....
.....

(c) The figure below shows a burning candle, weighted, driplless candle floating upright in water. Explain what happens after the candle burns for sometimes. **(2marks)**

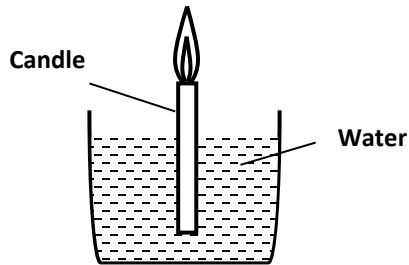

.....
.....
.....
.....

THIS IS THE LAST PRINTED PAGE