

NAME:CLASS:.....ADM NO:.....

SIGNATURE:.....INDEX NO:.....

DATE:.....

232/2
PHYSICS
PAPER 2
June 2022
TIME: 2 HOURS

KASSU JET – JUNE 2022
Kenya Certificate of Secondary Education
Physics Paper 2

Instructions to candidates

- Write your name, admission number, class, signature and date in the spaces provided at the top of the page.
- This paper consists of two sections A and B.
- Answer all the questions in the two sections in the spaces provided after each question
- All working must be clearly shown.
- Electronic calculators, mathematical tables may be used.
- All numerical answers should be expressed in the decimal notations.
- This paper consists of 12 printed pages. Candidates should check to ascertain that all pages are printed as indicated and that no questions are missing.

SECTION	QUESTION	MAX MARKS	CANDIDATE'S SCORE
A	1 – 10	25	
B	11		
	12		
	13		
	14		
	15		
TOTAL		80	

SECTION A: (25 MARKS)

Attempt all the questions in the spaces provided.

1. State the laws of reflection of light. (2 marks)

.....

.....

.....

2. State the two advantages of optical fibre over the ordinary cable. (2 marks)

.....

.....

.....

3. Derive the expression for the total electrical energy converted into heat in a wire of resistance, **R** when a current, **I** is maintained through it for a time, **t**. (3 marks)

.....

.....

.....

.....

4. A driver looked into his side mirror and saw a diminished image of a car behind him.

- (a) State the type of mirror the side mirror is made of. (1 mark)

.....

- (b) State two reasons why (a) above is preferred as side mirror. (2 marks)

.....

.....

.....

- (c) Define focal length of concave mirror. (1 mark)

.....

.....

5. State the basic law of electrostatics. (1 mark)

.....

.....

6. The diagram below shows the different parts of a loud speaker.

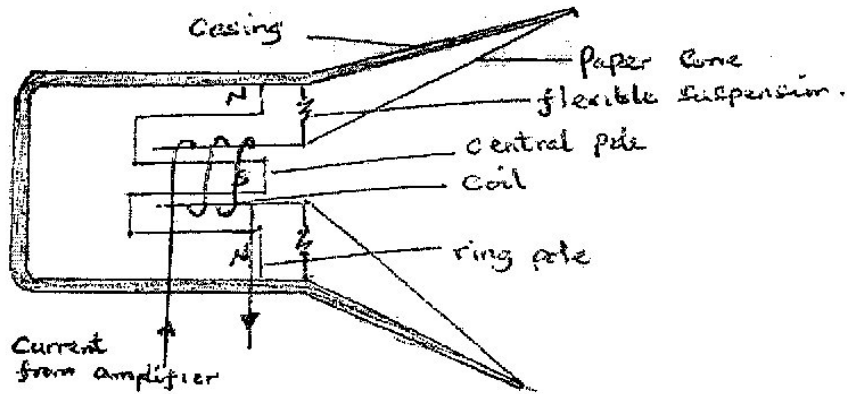

- State the role of the current from the amplifier. (2 marks)

.....

.....

.....

7. (a) You are provided with two iron bars, x and y, one is magnetized and the other is not. Explain how you would identify the magnetized bar without using a magnet. (2 marks)

.....

.....

.....

- (b) The figure below shows a set-up used to make a magnet.

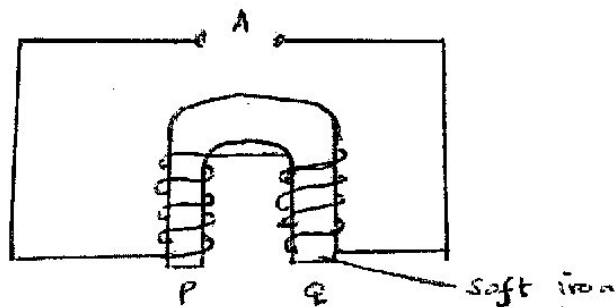

(i) Explain why soft iron is used. (1 mark)

.....
.....
.....

(ii) Complete the diagram to show how a battery should be connected at A so that the polarities of **P** and **Q** are south and North respectively. (1 mark)

8. A boy strikes a railway line with a hammer. A railway worker 60m away hears two sounds, one from the railway line and the other from air. If the time interval between the sounds is 0.16 seconds, and the average speed of the sound in air is 320 m/s. Determine the speed of sound in the rail. (3 marks)

.....
.....
.....
.....
.....
.....

9. (a) Define electric current. (1 mark)

.....
.....

(b) A current of 3A passes through bulb B for 3 minutes 45 seconds. Determine the quantity of charge through B. (2 marks)

.....
.....
.....
.....

10. State one way in which radio waves can be detected. (1 mark)

.....
.....

SECTION B (55 MARKS)

Attempt all the question in the spaces provided.

11. (a) State Faraday's law of electromagnetic induction. (1 mark)

.....

.....

- (b) A bar magnet is moved into a coil of insulated copper wire connected to a centre-zero galvanometer as shown below.

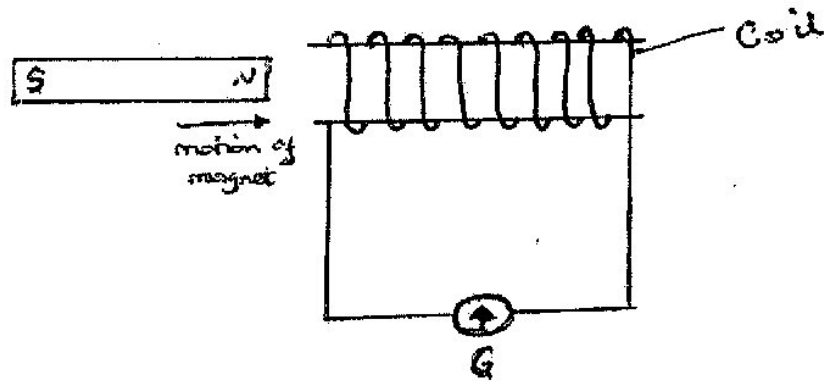

- (i) Show on the diagram, the direction of induced current in the coil. (1 mark)
- (ii) State and explain what is observed on the galvanometer when the north pole of the magnet is moved into and then withdrawn from the coil. (3 marks)

.....

.....

.....

.....

.....

.....

- (c) A transformer has 1000 turns in the primary and 40 turns in the secondary winding. The alternating e.m.f. connected to the primary is 240V and the current is 0.4A.

Determine:

- (i) The secondary voltage (e.m.f.) (2 marks)

.....

.....

.....

.....

(ii) The power in the secondary, if the transformer is 90% efficient. (3 marks)

.....

.....

.....

.....

.....

12. (a) State any two ways of decreasing the capacitance of a parallel-plate capacitor. (2 marks)

.....

.....

.....

(b) A metallic body shaped as shown below is positively charged and insulated from the ground.

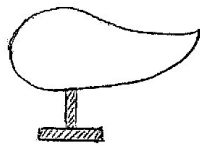

Show on the figure the charge distribution on the conductor. (1 mark)

(c) The figure below shows three capacitors A, B and C connected to a battery of e.m.f. 12.0V and zero internal resistance.

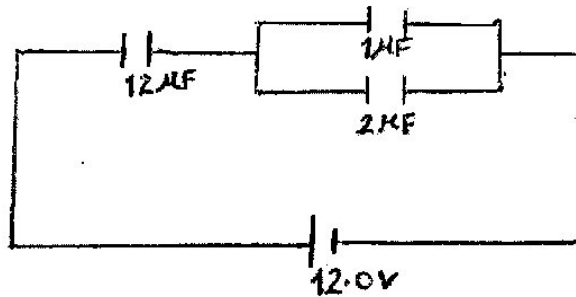

Determine:

(i) The effective capacitance of the circuit. (3 marks)

.....

.....

.....

.....

.....

.....

(ii) The p.d. across the $12\ \mu\text{F}$ capacitor. (3 marks)

.....

.....

.....

.....

.....

.....

(iii) Charge stored in the $1\ \mu\text{F}$ capacitor. (2 marks)

.....

.....

.....

.....

.....

13. (a) State Ohm's law. (1 mark)

.....

.....

.....

(b) The cell in figure has an e.m.f. of 2.6V and negligible internal resistance.

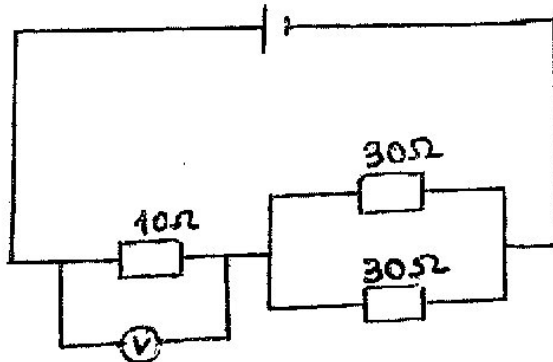

Determine the:

(i) Total resistance in the circuit (2 marks)

.....

.....

.....

.....

(ii) Current in the circuit

(2 marks)

.....

.....

.....

(iii) Reading on the voltmeter

(2 marks)

.....

.....

.....

(c) The graph below shows how the voltage, V , varies with the current, I for a filament lamp.

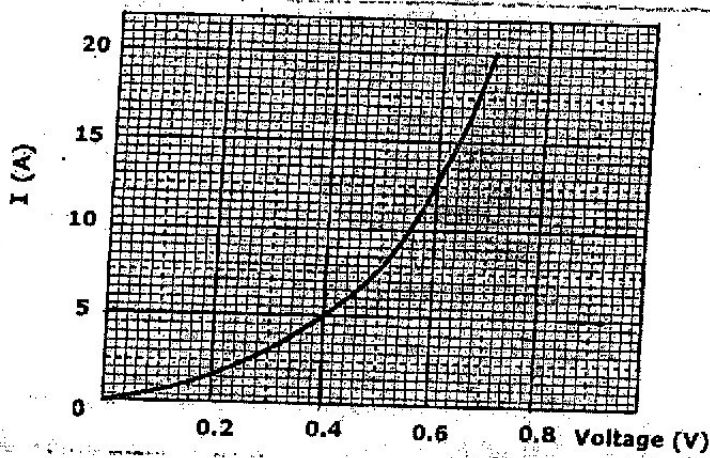

(i) From the graph, determine the resistance of the lamp when a current of 5A flows. (3 marks)

.....

.....

.....

.....

(ii) State with a reason whether the device is ohmic or non-ohmic. (2 marks)

.....

.....

.....

14. (a) (i) Define the term lens. (1 mark)

.....
.....

(ii) I. The figure below shows a convex lens with an object before it. Draw rays to identify the position of image formed.

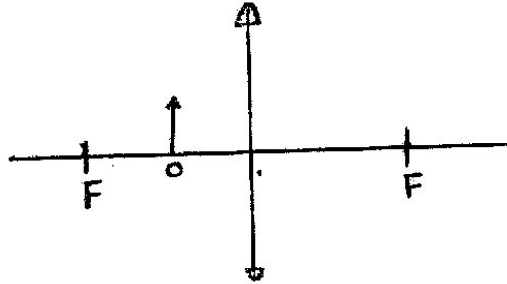

II. State one device in which such a set-up is used. (1 mark)

.....

(b) A lens forms an image that is four times the size of the object on a screen. The distance between the object and the screen is 150 cm when the image is sharply focused.

(i) State with reason the type of lens that was used. (2 marks)

.....
.....
.....

(ii) Determine the focal length of the lens. (4 marks)

.....
.....
.....
.....

15. (a) Distinguish between longitudinal and transverse wave (1 mark)

.....
.....
.....

(b) The figure below shows the displacement- time and displacement-distance graphs of a certain wave.

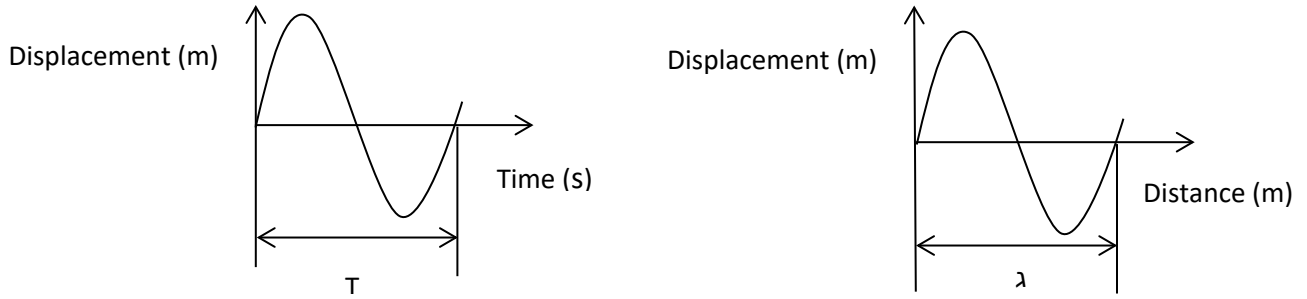

From the information above show that the speed of the wave = frequency X wavelength
($c=f\lambda$). (2 marks)

.....

.....

.....

.....

.....

(c) Figure shows two speakers connected to an audio – frequency generator.

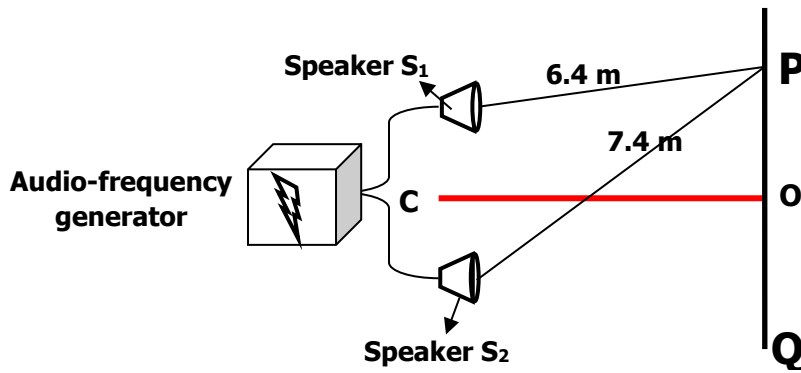

(i) Give reason why the loudspeakers are connected to the same audio – frequency generator. (1 mark)

.....

.....

(ii) State and explain the observation made by an observer moving along the path **PQ**.

(2 marks)

.....
.....
.....

(iii) State the observations made if the frequency of the signal generator was increased.

(1 mark)

.....
.....
.....

(iv) Explain the observation made when the distance **CO** was increased.

(1 mark)

.....
.....

(v) If the distances S_1P and S_2P are 6.4m and 7.4m respectively. Determine the frequency of the signal generator from the set up above given that **P** is the first constructive interference after the central order and the velocity of sound is **320m/s**. (3 marks)

.....
.....
.....
.....
.....
.....

END

This is the last printed page.