



232/3 -

**PHYSICS
(PRACTICAL)**

- Paper 3

Nov. 2017 - 2½ hours

Name Index Number

Candidate's Signature Date

Instructions to candidates

- (a) Write your name and index number in the spaces provided above.
- (b) Sign and write the date of examination in the spaces provided above.
- (c) Answer **all** the questions in the spaces provided in the question paper.
- (d) You are supposed to spend the first 15 minutes of the 2½ hours allowed for this paper reading the whole paper carefully before commencing your work.
- (e) Marks are given for a clear record of the observations actually made, their suitability, accuracy and the use made of them.
- (f) Candidates are advised to record their observations as soon as they are made.
- (g) **Non-programmable** silent electronic calculators may be used.
- (h) **This paper consists of 8 printed pages.**
- (i) **Candidates should check the question paper to ascertain that all the pages are printed as indicated and that no questions are missing.**
- (j) **Candidates should answer the questions in English.**

For Examiner's Use Only

Question 1	a	b	c	d	e
Maximum Score	1	1	6	4	8
Candidate's Score					

Total

Question 2	a	b	c	d	e	f	g	h	i	j	k
Maximum Score	2	2	0	1	2	4	1	1	1	4	2
Candidate's Score											

Total

Grand Total



PART A

1. You are provided with the following:

- One dry cell in a cell holder
- One milliammeter
- A resistor labelled R1
- A chain of six resistors
- A switch
- Connecting wires

Proceed as follows:

(a) Set up the circuit as shown in **Figure 1**

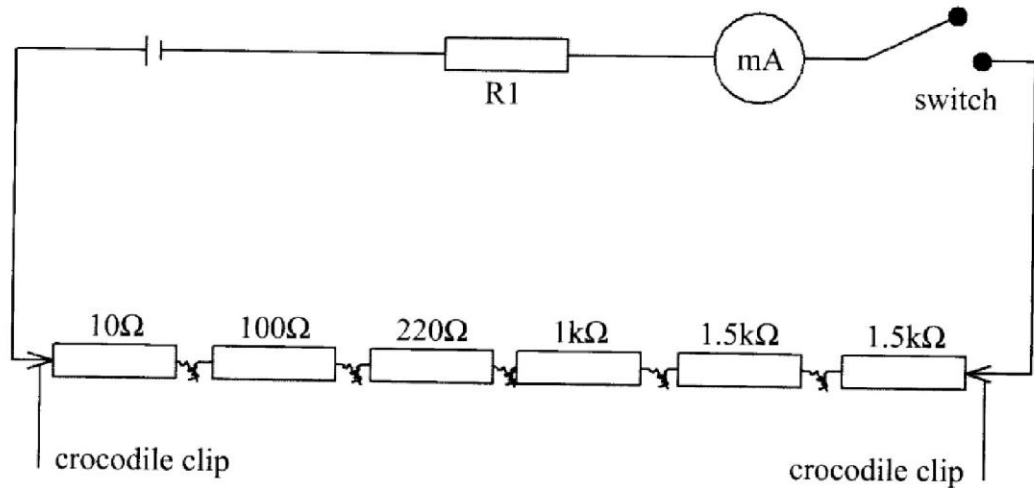

Figure 1

Switch on the circuit to obtain a positive deflection in the milliammeter. Record the reading I_1 of the milliammeter.

$$I_1 = \dots\dots\dots \text{ mA} \quad (1 \text{ mark})$$

(b) Remove the crocodile clips from the ends of the chain of resistors and connect them across two resistors in the resistance chain that add up to $3.0 \text{ k}\Omega$. Record the reading of the milliammeter I_2 .

$$I_2 = \dots\dots\dots \text{ mA} \quad (1 \text{ mark})$$

(c) Repeat the procedure in (b) for other values of resistance R shown in **Table 1** and complete **Table 1**.

(Hint: The values of R may be obtained by combining two or more resistors in the chain)

Table 1

(6 marks)

$R \times 10^3 (\Omega)$	0.330	1.0	1.33	1.5	2.5	4.0
I (mA)						
I (A)						
$\frac{1}{I}$ (A ⁻¹)						

(d) Plot a graph of $\frac{1}{I}$ (y axis) against R

(4 marks)

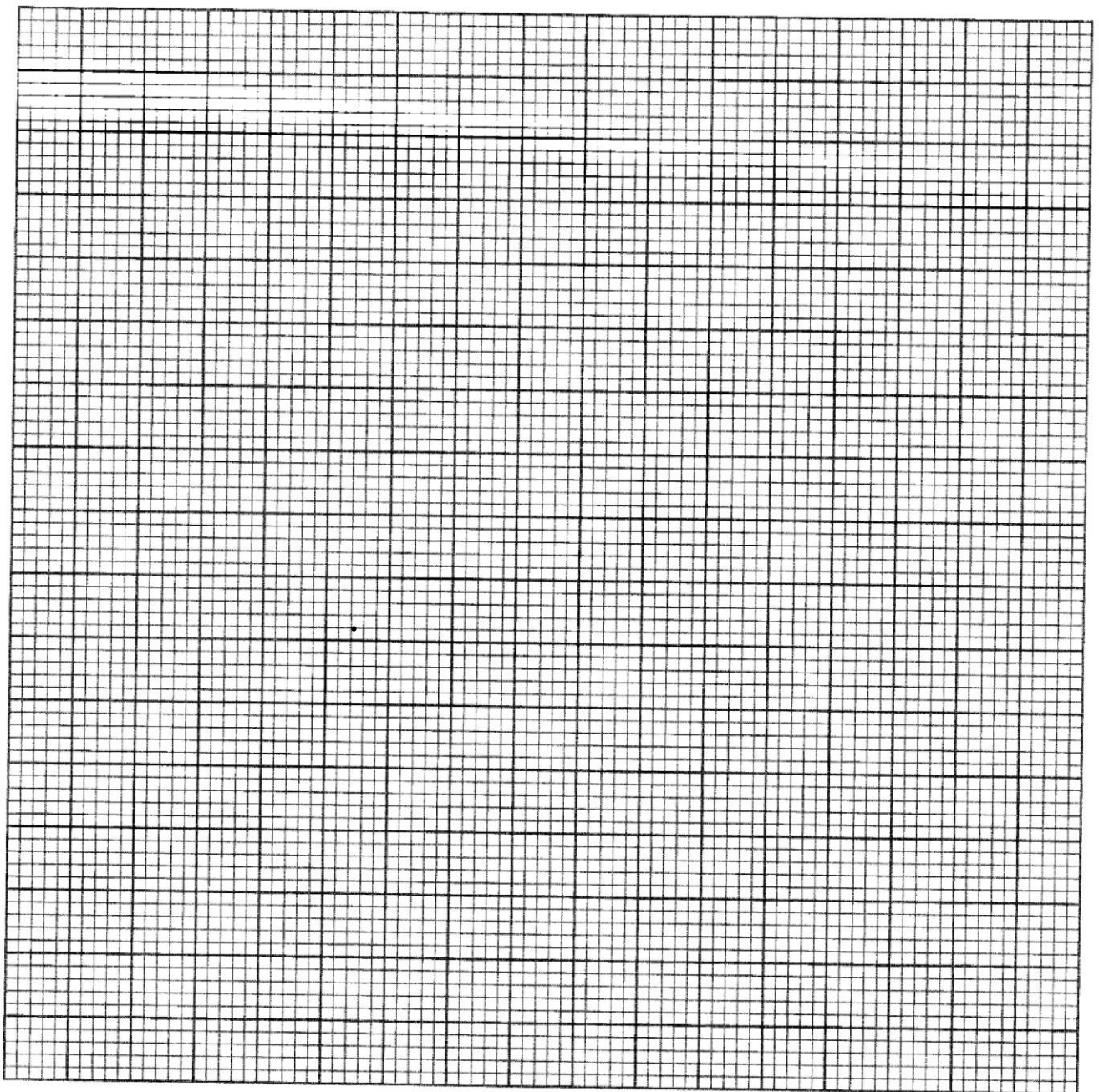

(e) (i) Determine the slope S of the graph. (3 marks)

.....
.....
.....

(ii) Given the equation $E = I(R+R_1)$ determine the values of:

(I) E . (3 marks)

.....
.....
.....

(II) R_1 . (2 marks)

.....
.....
.....
.....

NB: The plain sheet of paper must be submitted together with the question paper.

- (b) At a point about a thirdway along one side of the outline from angle A, draw a normal. (2 marks)
- (c) Draw a line at angle $i = 40^\circ$ to the normal. Stick two pins P_1 and P_2 vertically on this line. (see Figure 3).

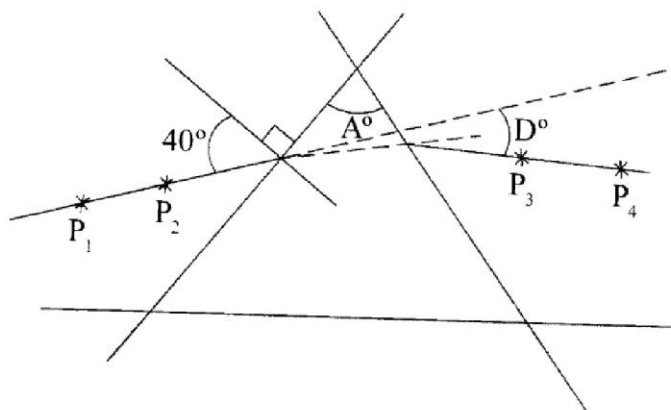

Figure 3

Place the prism accurately on the outline. By viewing through the opposite side, stick two other pins P_3 and P_4 vertically such that they are in line with the two images of pins P_1 and P_2 .

- (d) Remove the prism and the pins. Draw a line joining the marks made by P_3 and P_4 . Extend lines $P_1 P_2$ and $P_3 P_4$ to intersect. Hence measure the angle of deviation D .
 $D = \dots\dots\dots$ (1 mark)
- (e) For two other values of angle i shown in **Table 2** locate and measure the corresponding angles of deviation. Complete **Table 2**.

Table 2

(2 marks)

i	40°	50°	60°
D			

- (f) (i) Determine the average value D_m of D . (1 mark)

.....

.....

.....

(ii) Determine the constant K using the equation;

(3 marks)

$$k = \frac{\sin\left(\frac{A + D_m}{2}\right)}{\sin\frac{A}{2}}$$

.....

.....

.....

PART B*(Read all the instructions before starting this part)*

- (g) Using the thermometer measure and record the temperature of the room
- θ
- .

 $\theta = \dots\dots\dots$ °C (1 mark)

- (h) Using the 250 ml beaker, collect 200 ml of hot water from the boiling water source. Place the thermometer into the hot water and wait until the water cools to 80°C then start the stopwatch and record the time
- t_1
- it takes the water to cool to 75°C.

 $t_1 = \dots\dots\dots$ seconds (1 mark)

- (i) Wait until the water cools to 70°C then start the stopwatch and record the time
- t_2
- it takes the water to cool to 65°C.

 $t_2 = \dots\dots\dots$ seconds (1 mark)

- (j) Determine the rate of temperature change
- X
- and
- Y
- in the two time intervals;

(I) $X = \frac{77.5 - \theta_0}{t_1}$, (2 marks)

.....

.....

.....

(II) $Y = \frac{67.5 - \theta_0}{t_2}$. (2 marks)

.....

.....

.....

- (k) State with a reason how the rate of change of temperature between 90°C to 85°C compares with
- X
- . (2 marks)

.....

.....

.....

THIS IS THE LAST PRINTED PAGE.