



232/1 –

PHYSICS
(THEORY)

– Paper 1

Nov. 2017 – 2 hours

Name Index Number

Candidate's Signature Date

Instructions to candidates

- (a) Write your name and index number in the spaces provided above.
- (b) Sign and write the date of examination in the spaces provided above.
- (c) This paper consists of **two** sections: **A** and **B**.
- (d) Answer **all** the questions in sections **A** and **B** in the spaces provided.
- (e) **All** workings **must** be clearly shown.
- (f) Silent non programmable electronic calculators may be used.
- (g) **This paper consists of 13 printed pages.**
- (h) **Candidates should check the question paper to ascertain that all the pages are printed as indicated and that no questions are missing.**
- (i) **Candidates should answer the questions in English.**

For Examiner's Use Only

Section	Questions	Maximum Score	Candidate's Score
A	1–13	25	
B	14	11	
	15	12	
	16	10	
	17	11	
	18	11	
Total Score		80	



SECTION A: (25 marks)

Answer all the questions in this section in the spaces provided.

1. In order to determine the size of an oil molecule, a student performed an experiment using five oil drops to make a circular patch of the oil on the surface of water in a waterbath. State two assumptions made by the student during the calculations. (2 marks)

.....

.....

.....

2. In an experiment to determine the density of Liquid R, a student obtained the followed data:
- Mass of an empty density bottle = 55.0 g
 - Mass of the density bottle + water = 80.0 g
 - Mass of the density bottle + Liquid R = 70.0 g

Determine the density of Liquid R. (*density of water is 1000 kgm^{-3}*) (3 marks)

.....

.....

.....

.....

3. It is observed that when 20 cm^3 of alcohol is mixed with 20 cm^3 of water, the volume of the mixture is 39 cm^3 . State a reason why the volume of the mixture is **not** 40 cm^3 . (1 mark)

.....

.....

4. When a liquid is heated in a glass flask, it is observed that the level at first goes down and then rises. Explain this observation. (2 marks)

.....

.....



5. **Figure 1** shows a uniform wooden bar at equilibrium with two cans Y and Z of equal mass but different diameters.

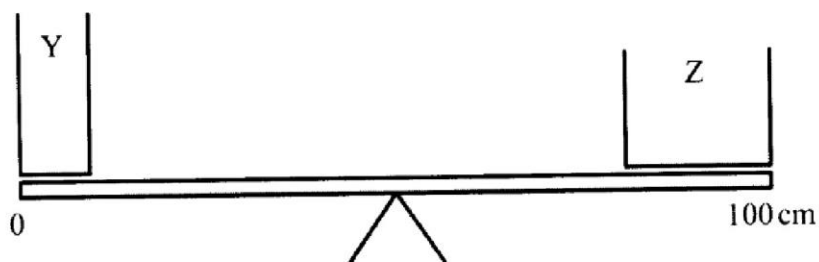

Figure 1

The cans are simultaneously filled with equal volumes of water.

Explain the observation made.

(2 marks)

.....

.....

6. State the reason why the speed of water at the narrow section of a river is higher than at the wider section. (1 mark)

.....

.....

7. A stone is thrown vertically upwards. Sketch a graph of potential energy (y axis) against time as the stone moves until it hits the ground. (1 mark)



8. Using the definition of impulsive force, show that $F = ma$ (3 marks)

.....

.....

.....

.....

9. **Figure 2** shows a round bottomed flask fitted with a long capillary tube containing a drop of coloured water.

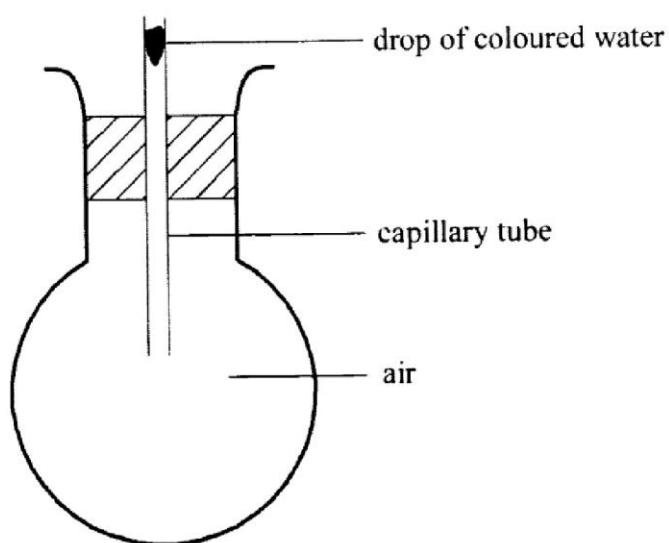

Figure 2

- The flask is immersed in ice water for sometime. State the observation made. (2 marks)

.....

.....

10. State **one** assumption for the experiments carried out to verify the gas laws. (1 mark)

.....

.....



11. A student who wanted to take a bath mixed 4 kg of water at 80 °C with 6 kg of water at 20 °C. Determine the final temperature of the water. (3 marks)

.....

.....

.....

.....

12. A uniform metre rule is pivoted at its centre. Two weights of 20 N and 10 N are suspended at the 20 cm and 100 cm marks respectively. Determine the position at which a 10 N weight should be suspended in order to balance the system. (3 marks)

.....

.....

.....

.....

13. Figure 3 shows two possible designs of a three legged stool.



Figure 3

State a reason why B is more stable than A. (1 mark)

.....

.....



SECTION B: (55 marks)

Answer all the questions in this section in the spaces provided.

14. (a) A tape attached to an accelerating trolley passes through a ticker timer that makes dots on it at a frequency of 50 Hz. The ticker timer makes 10 dots on a 10 cm long tape such that; the distance **a** between the first two dots is 0.5 cm and the distance **b** between the last two dots is 1.5 cm.

(i) Determine the velocity of the trolley at:

(I) distance **a**, (4 marks)

.....
.....
.....
.....

(II) distance **b**, (2 marks)

.....
.....
.....
.....

(ii) Determine the acceleration of the trolley. (3 marks)

.....
.....
.....
.....

(b) State with a reason what would be observed on the spacing between the dots on the tape when the trolley is made to move on a horizontal surface. (2 marks)

.....
.....



15. (a) A student was provided with several identical masses, a metre rule, a spring and a stand, boss and clamp. Outline five steps that the student should follow in order to verify Hooke's law. (5 marks)

.....

.....

.....

.....

.....

.....

.....

- (b) **Figure 4** shows a graph that was drawn from the results obtained in an experiment to study the extension of a spring.

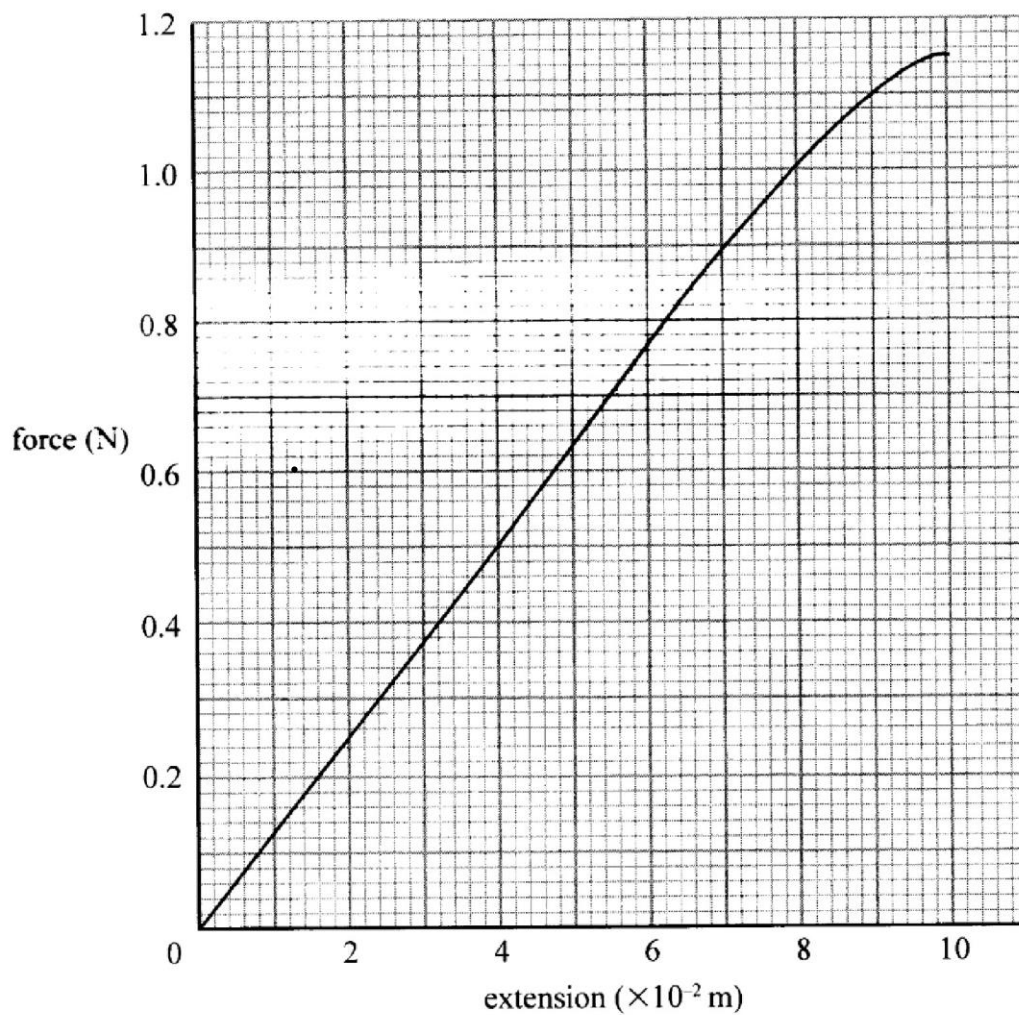

Figure 4



From the graph determine;

- (i) The spring constant K , (3 marks)

.....

- (ii) The load that causes an extension of 3×10^{-2} m. (1 mark)

.....

- (c) Three identical springs of spring constant 100 Nm^{-1} are arranged as shown in **Figure 5** to support a 5 N load.

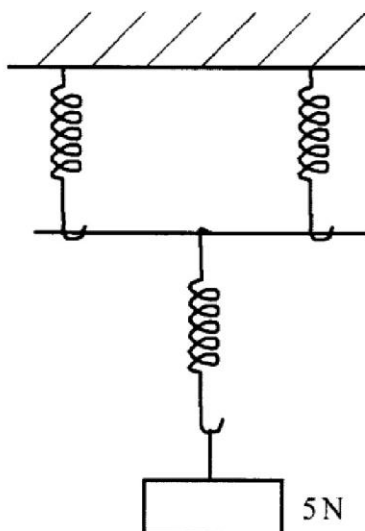

Figure 5

Determine the total extension in the arrangement. (3 marks)

.....



16. (a) In an experiment to determine the size of an oil molecule, oil is placed on the surface of water after sprinkling lycopodium powder on it.

(i) State **two** reasons why oil is used. (2 marks)

.....
.....
.....
.....

(ii) State the function of the lycopodium powder. (1 mark)

.....

(iii) State **any two** assumptions that are made in this experiment. (2 marks)

.....
.....
.....
.....

(iv) Explain why the oil spreads on the surface of water. (2 marks)

.....
.....
.....

(b) The following data was obtained from an experiment to determine the size of a palm oil molecule.

- Volume of 100 drops of palm oil = 15.0 mm³
- Area of a patch from one drop of oil = 8.0 × 10⁴ mm²

Determine the size of a palm oil molecule. (3 marks)

.....
.....
.....



17. (a) State the law of flotation. (1 mark)

.....

.....

.....

- (b) **Figure 6** shows two solids W and X made of the same material and immersed in water.

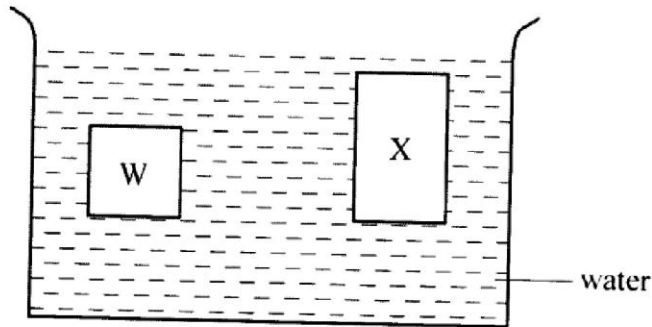

Figure 6

- (i) State with a reason which one of the containers experiences a greater upthrust. (2 marks)

.....

.....

.....

- (ii) Solid W weighs 12N in air, 2N in water and 4N in another liquid. Determine the density of the other liquid. (3 marks)

.....

.....

.....



- (c) **Figure 7** shows two identical wooden blocks each of mass 0.2 kg suspended in water by two strings **M** and **N**.

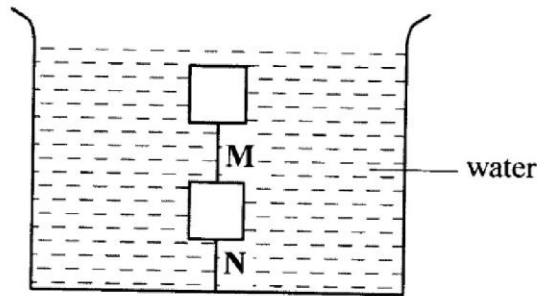

Figure 7

Given that the upthrust on each block is 3.2 N, determine the tension in string;

- (i) **M**, (2 marks)

.....

.....

- (ii) **N**. (2 marks)

.....

.....

- (d) State any **one** application of hydrometers. (1 mark)

.....

.....



18. (a) **Figure 8** shows part of a hydraulic brake system.

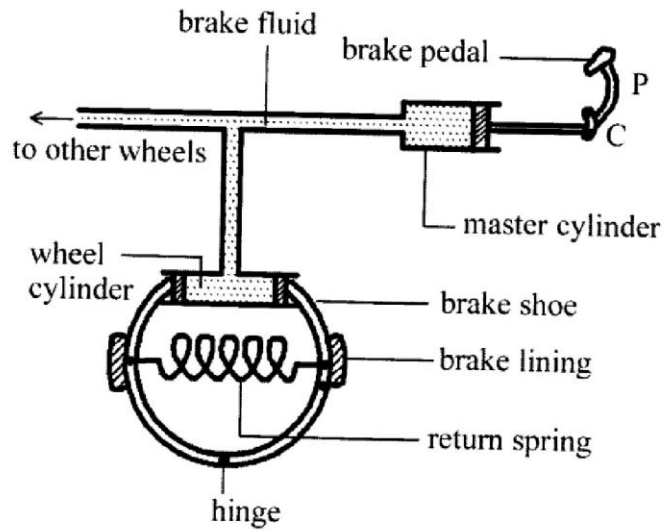

Figure 8

Describe how the systems works.

(5 marks)

.....

.....

.....

.....

.....

.....

.....

.....

- (b) State **three** conditions necessary for a driver to negotiate a bend on a flat level road at a relatively high speed. (3 marks)

.....

.....

.....

.....



- (c) **Figure 9** shows two identical cans U and V each with a small opening at the top. Different amounts of water were put into the cans and heated until the water started to boil.

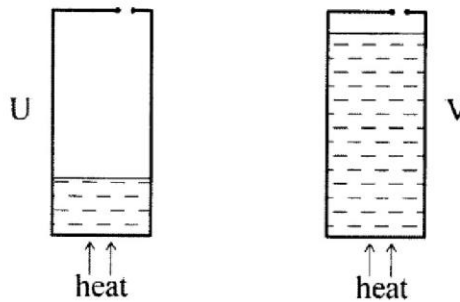

Figure 9

Explain what will be observed when both cans are then suddenly dipped into a cold waterbath. (3 marks)

.....

.....

.....

.....

THIS IS THE LAST PRINTED PAGE.

