

232/2

Paper 2

**PHYSICS – (Theory)**

**Mar. 2022 – 2 hours**



Name ..... Index Number .....

Candidate's Signature ..... Date .....

**Instructions to candidates**

- (a) Write your name and index number in the spaces provided above.
- (b) Sign and write the date of examination in the spaces provided above.
- (c) This paper consists of **two** Sections; **A** and **B**.
- (d) Answer **all** the questions in Sections **A** and **B** in the spaces provided.
- (e) **All** working **must** be clearly shown in the spaces provided in this booklet.
- (f) Non-programmable silent electronic calculators may be used.
- (g) **This paper consists of 16 printed pages.**
- (h) **Candidates should check the question paper to ascertain that all the pages are printed as indicated and that no questions are missing.**
- (i) **Candidates should answer the questions in English.**

**For Examiner's Use Only**

Section	Questions	Maximum Score	Candidate's Score
<b>A</b>	<b>1-13</b>	<b>25</b>	
<b>B</b>	<b>14</b>	<b>10</b>	
	<b>15</b>	<b>12</b>	
	<b>16</b>	<b>9</b>	
	<b>17</b>	<b>13</b>	
	<b>18</b>	<b>11</b>	
<b>Total Score</b>		<b>80</b>	



**SECTION A (25 marks)**

Answer *all* the questions in this section in the spaces provided.

1. **Figure 1** shows a ray of light incident on a plane mirror.

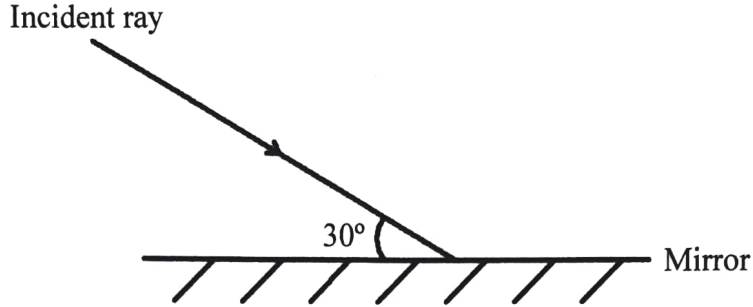
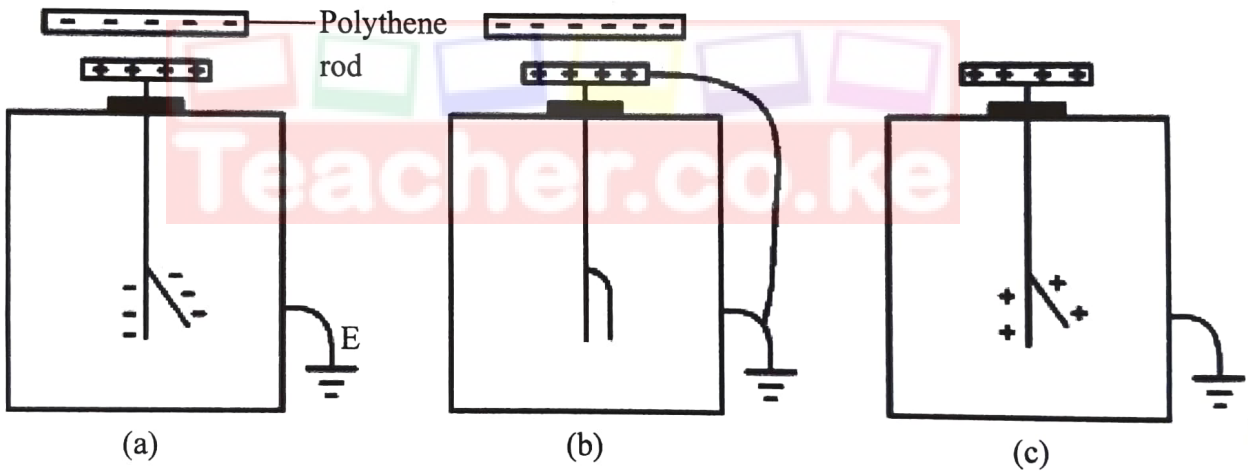

**Figure 1**

Complete the diagram to show the path of the reflected ray.

(1 mark)

2. **Figure 2a, 2b and 2c** show the process of charging an electroscope by induction.



**Figure 2**

It is observed that the leaf rises in (a), collapses in (b) and then rises in (c). Explain why the leaf collapses in (b). (3 marks)

.....

.....

.....



3. State **one** use of capacitors. (1 mark)

.....  
.....

4. **Figure 3** shows a graph of magnetic strength against time for two nails P and Q when magnetised in a solenoid. P and Q are of the same size but are made of different materials.

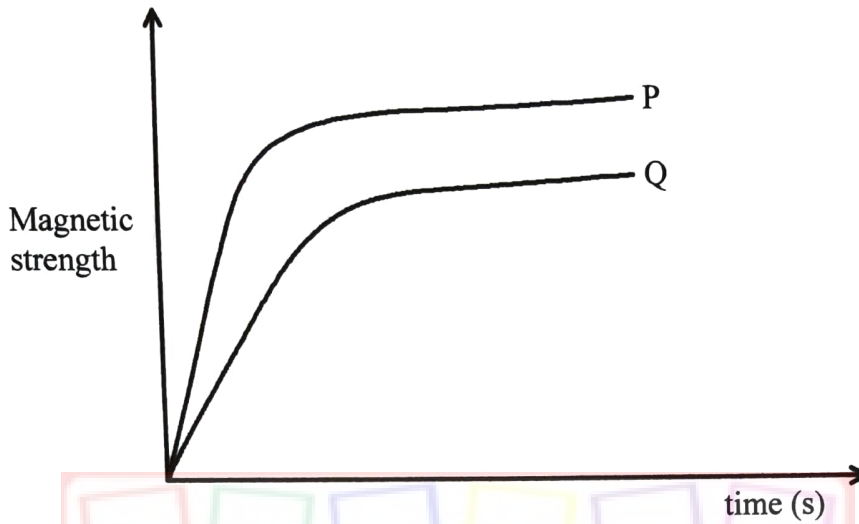

Figure 3  
Teacher.co.ke

(a) Identify the material that is magnetised faster. (1 mark)

.....

(b) Use the domain theory to explain the answer in 4(a). (2 marks)

.....  
.....  
.....  
.....

5. State the meaning of the term *principal focus* of a convex mirror. (1 mark)

.....  
.....



6. **Figure 4** shows a current carrying conductor placed between the poles of two magnets. (The direction of the current is into the paper).



**Figure 4**

Sketch the magnetic field produced between the conductor and the poles of the magnets. (2 marks)

7. **Figure 5** shows two coherent sources of sound A and B in phase. O is a point equidistant from A and B.



**Figure 5**

An observer moves from M to N through Q. Explain what is observed at point Q. (3 marks)

.....

.....

.....

.....

8. State **one** factor that affects the speed of sound in water. (1 mark)

.....  
.....

9. **Figure 6** shows a ray of light incident on a prism with a critical angle of  $42^\circ$ .

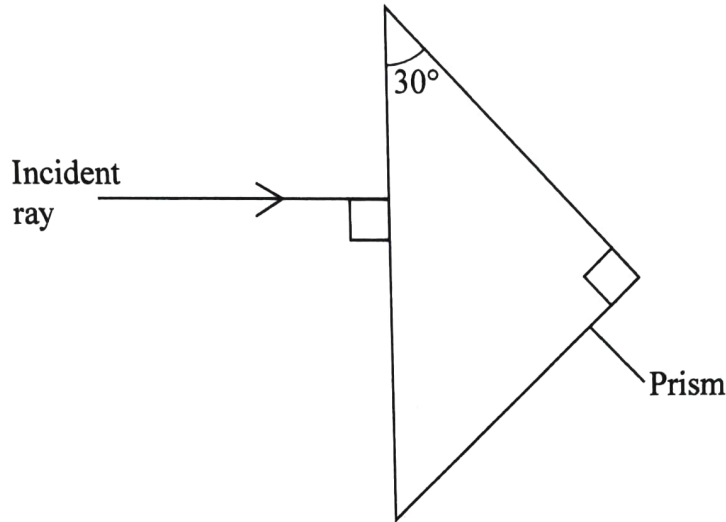

**Figure 6**

Complete the diagram to show the path of the ray through the prism. (2 marks)

10. It is observed that when the heat current of the cathode ray tube is increased, the intensity of the cathode rays increase. Explain this observation. (2 marks)

.....  
.....  
.....  
.....

11. A current of 2A flows through a bulb for 2.5 minutes. Determine the quantity of charge that flows through the bulb. (3 marks)

.....  
.....  
.....

Download this and other FREE materials from <https://teacher.co.ke/notes>



12. **Figure 7** shows UV light passing through an aperture and incident on the cathode of a photocell.

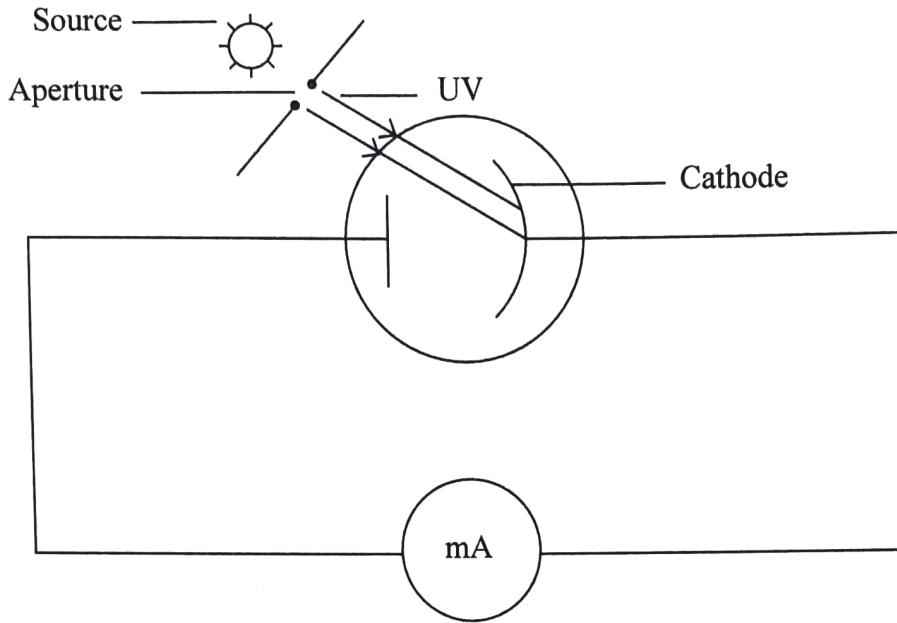

**Figure 7**

- (a) State what is observed on the milliammeter when the size of the aperture is increased. (1 mark)

.....  
 .....

- (b) State the reason for the answer in 12(a) (1 mark)

.....  
 .....

13. State the property of radio waves that makes them suitable for use in communication. (1 mark)

.....  
 .....

436

A070



## SECTION B

*Answer **all** the questions in this section in the spaces provided.*

14. (a) State and explain how increase in temperature affects the conductivity of a semiconductor. (2 marks)

.....

.....

.....

- (b) **Figure 8** shows a graph of potential difference (V) across a bulb against the current (I) through the bulb obtained from an experiment.

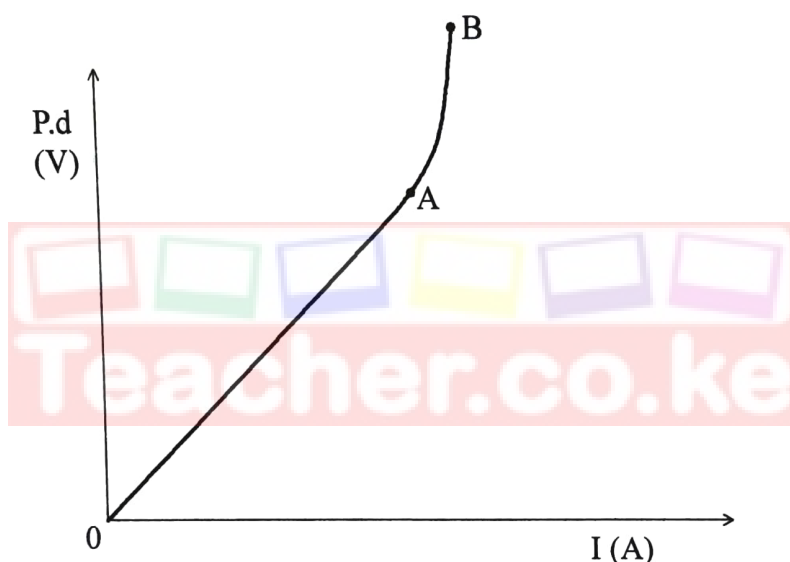

**Figure 8**

Explain why parts:

- (i) OA is straight. (1 mark)

.....

.....

- (ii) AB is curved. (2 marks)

.....

.....



- (c) A circuit consists of 20 identical lamps connected in series to 240 V mains supply. Determine the potential difference across each of the lamps. (2 marks)

.....

.....

.....

.....

- (d) **Figure 9** shows a circuit consisting of two identical lamps and three ammeters  $A_1$ ,  $A_2$  and  $A_3$  connected to a cell.

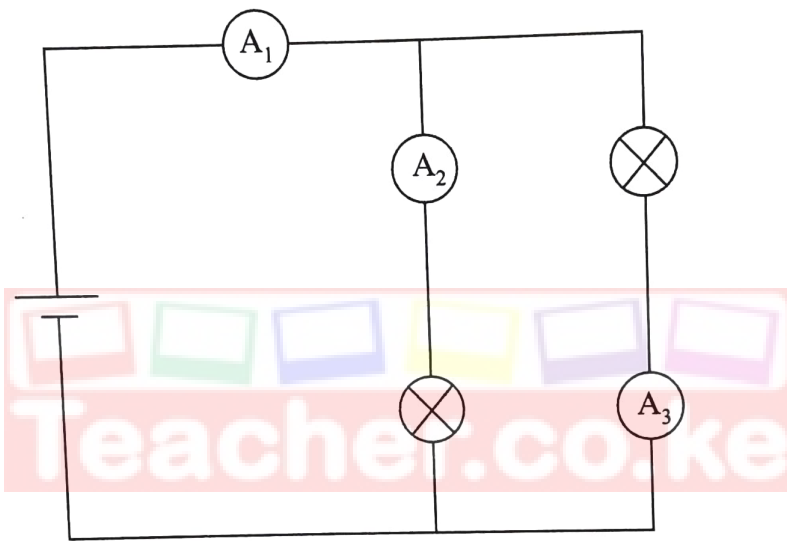

**Figure 9**

Given that ammeter  $A_1$  reads 0.5 A:

- (i) state the reading on Ammeter  $A_3$ . (1 mark)

.....

.....

- (ii) explain the answer 14(d)(i). (2 marks)

.....

.....

.....





15. (a) State the use of the eye piece lens in a compound microscope. (1 mark)

.....  
 .....

(b) On the grid provided, draw a ray diagram to show how a convex lens forms a magnified real image. (3 marks)

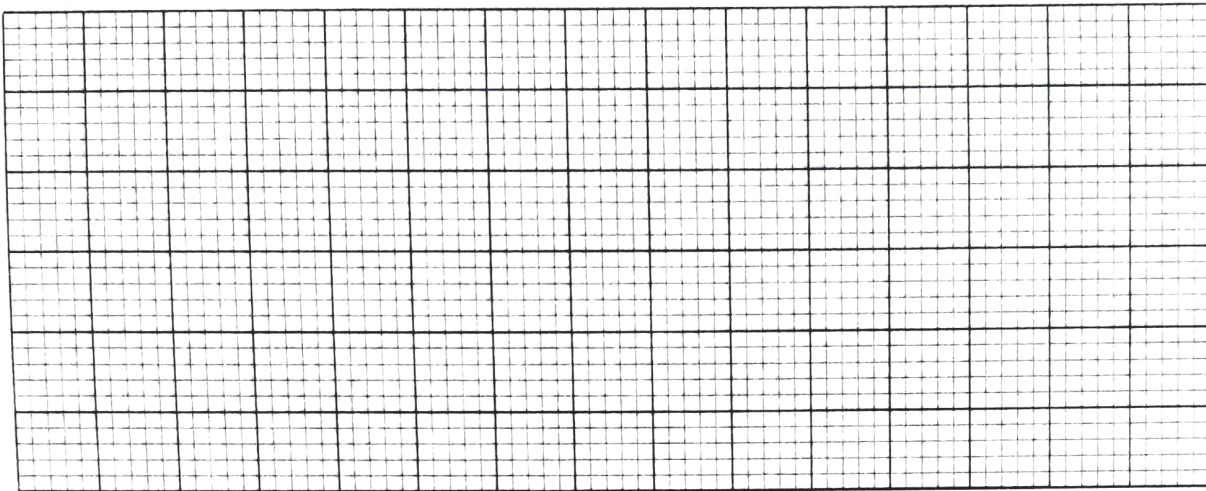

(c) **Figure 10** shows a defect of vision in a human eye.

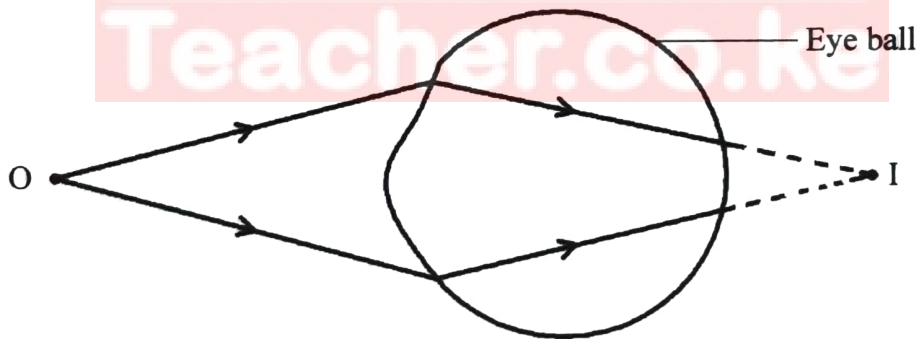

**Figure 10**

(i) State the type of defect shown. (1 mark)

.....

(ii) State the type of lens that can be used to correct this defect. (1 mark)

.....

(iii) On the same figure, draw rays to show how the lens in 15(c)(ii) corrects the defect. (2 marks)

Download this and other FREE materials from https://www.teacher.co.ke/notes

- (d) **Figure 11** shows a graph of image distance ( $V$ ) against the object distance ( $U$ ) obtained in an experiment to determine the focal length of a concave mirror.

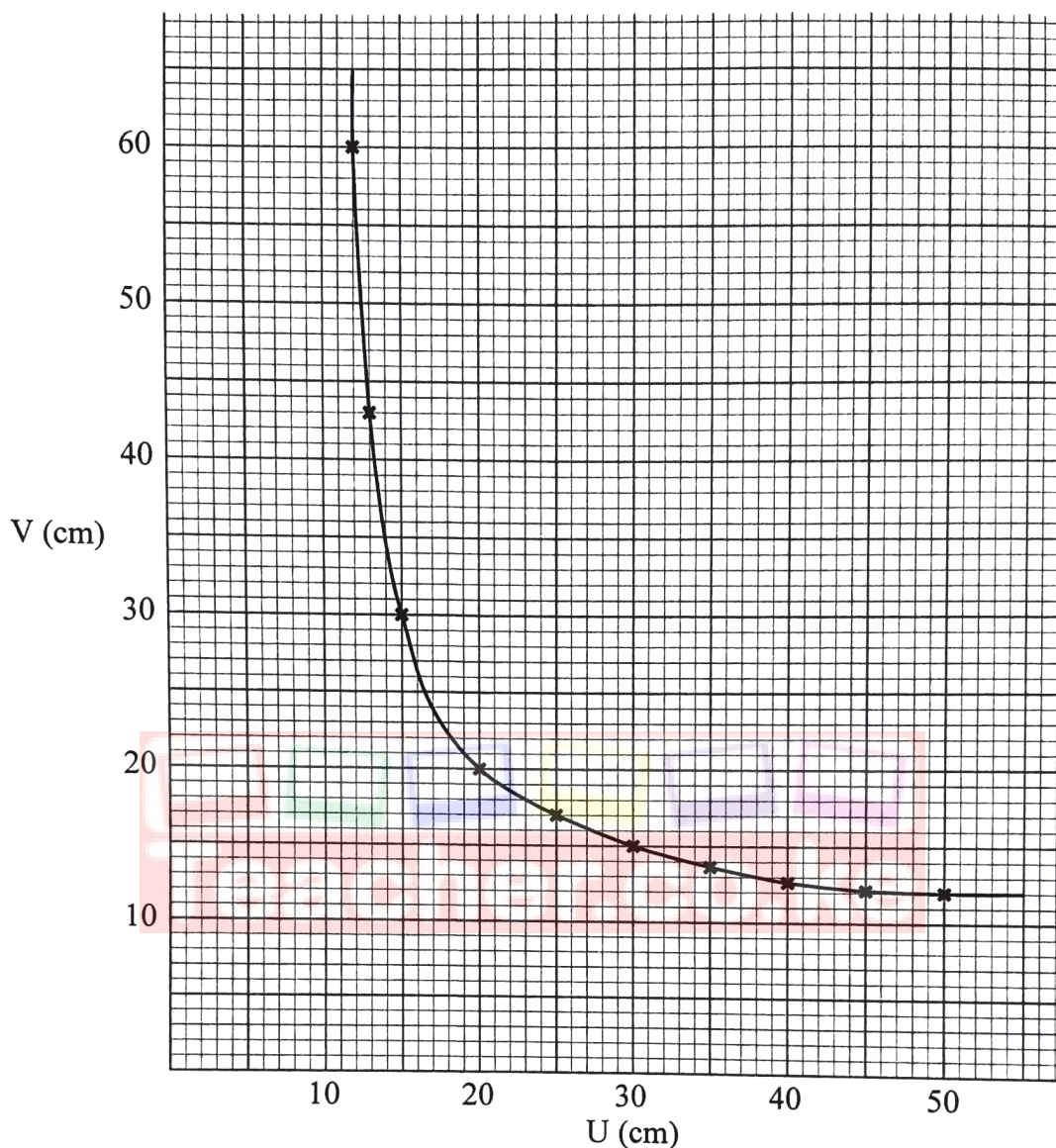

**Figure 11**

- (i) Identify and mark a point  $X$  on the graph where  $V = U$ . (1 mark)
- (ii) Use the point  $X$  to determine:
- I. the radius of curvature  $r$ . (2 marks)
- .....
- .....
- II. the focal length of the lens  $f$ . (1 mark)
- .....
- .....

16. (a) State Faraday's law of electromagnetic induction. (1 mark)

.....

.....

.....

(b) Figure 12 shows a bar magnet being moved towards a solenoid. The solenoid is connected to a galvanometer.

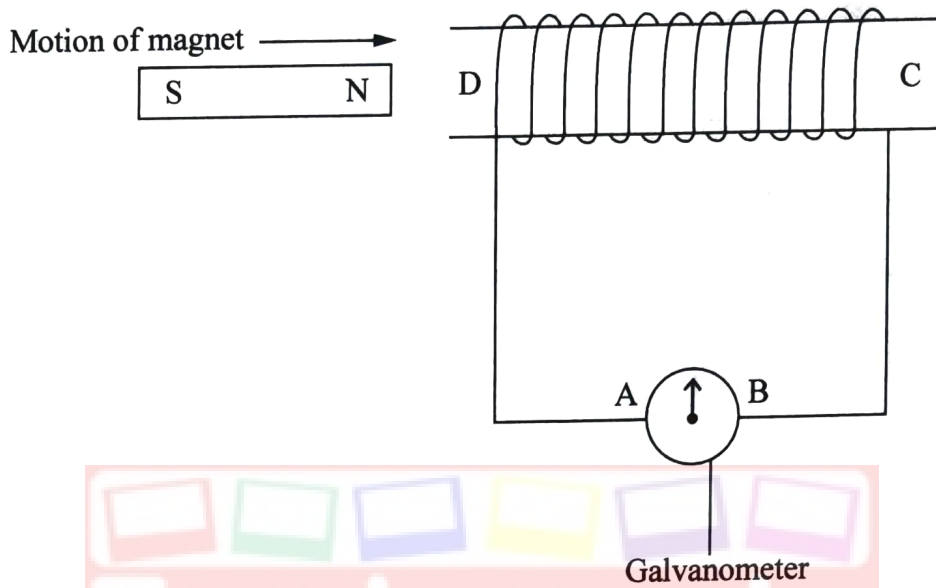

Figure 12

- (i) Indicate on the diagram the direction of the induced current in the solenoid. (1 mark)
- (ii) Identify the pole induced at D. (1 mark)
- (iii) Explain the answer in 16(b)(ii). (2 marks)

.....

.....

.....

.....

.....

.....

.....

Download this and other FREE materials from <https://teacher.co.ke/notes>

(iv) Apart from the number of turns in the solenoid, state **two** factors affecting the magnitude of the induced current. (2 marks)

.....

.....

.....

.....

.....

.....

(c) Explain how laminating the core of a transformer increases its efficiency. (2 marks)

.....

.....

.....

.....

.....

.....



436

A070

Download this and other FREE materials from <https://teacher.co.ke/notes>



17. (a) Explain how a fuse protects electrical devices from damage. (2 marks)

.....

.....

.....

.....

- (b) State and explain why the voltage in mains electricity is stepped up before long distance transmission. (3 marks)

.....

.....

.....

.....

- (c) **Figure 13** shows how power can be transmitted from the generating station through transformers P, Q and R to the consumers.

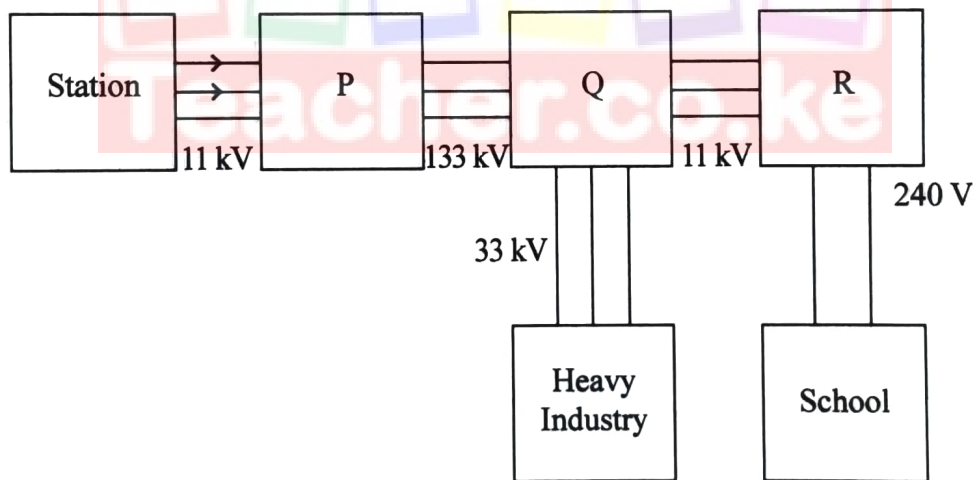

**Figure 13**

- (i) Identify the type of transformer labelled P. (1 mark)

.....

Download this and other FREE materials from <https://teacher.co.ke/notes>

- (ii) Explain how the number of turns in the primary and secondary coils of transformer P affects its output voltage. (3 marks)

.....

.....

.....

.....

- (iii) State the reason why one of the wires from R to the school should be earthed. (1 mark)

.....

.....

.....

- (d) A power station generates 11 kV at a current of 1A. The voltage is stepped up to 160 kV before being transmitted through electric cables. Assuming the transformer is 100% efficient, determine the secondary current. (3 marks)

.....

.....

.....

.....

.....



18. (a) **Figure 14** shows a cathode ray tube. A metal plate is placed between the anode and the screen.

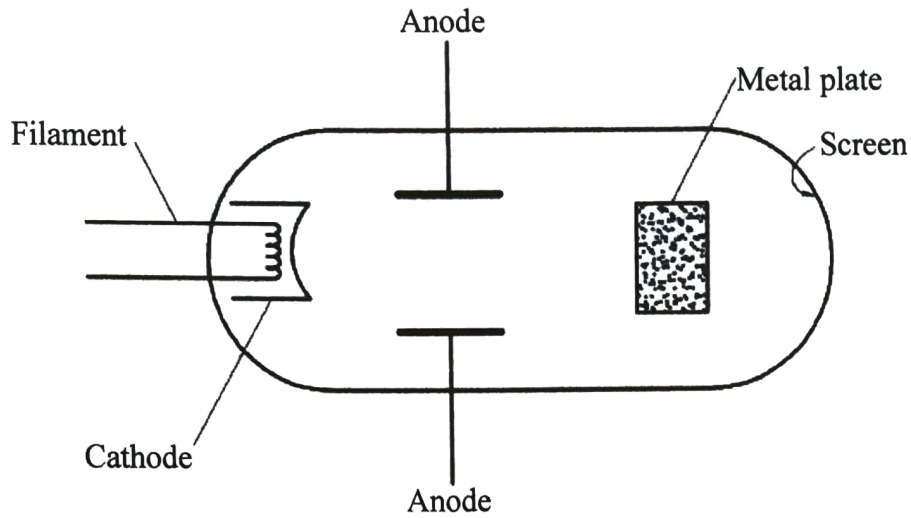

**Figure 14**

- (i) State with a reason what would be observed on the screen when the cathode rays are produced. (2 marks)

.....  
 .....  
 Teacher.co.ke  
 .....

- (ii) State the effect on the cathode rays produced when the anode potential is increased. (1 mark)

.....  
 .....  
 .....

- (b) Explain how X-rays produce photographs of fractures in bones. (2 marks)

.....  
 .....  
 .....

Download this and other FREE materials from <https://teacher.co.ke/notes>



- (c) **Figure 15** shows monochromatic light incident on the cathode of a photo cell connected to a milliammeter (mA) and three cells in series. The anode of the photocell may be connected to points P, Q, R and S through a jockey.

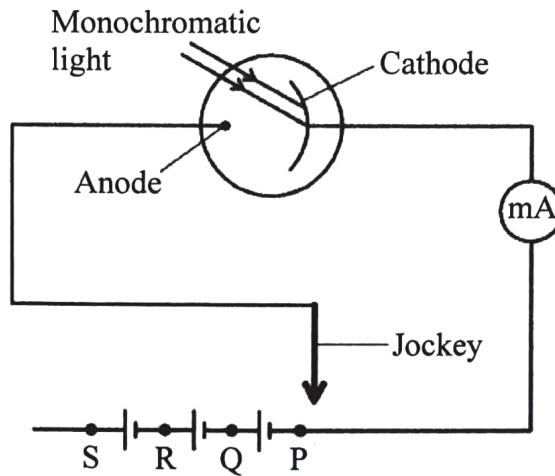

**Figure 15**

State what would be observed when the jockey is:

- (i) connected to point P. (1 mark)

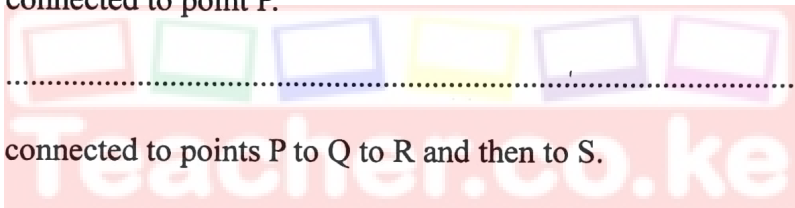

- (ii) connected to points P to Q to R and then to S. (1 mark)

- (d) Explain the answer in (c)(ii) (2 marks)

- (e) State how radioactivity may be used to detect oil leakage in an underground pipeline. (2 marks)

**THIS IS THE LAST PRINTED PAGE.**

