

L.C.M

1. a) Find the greatest common divisor of the term.
(1 mark)

$$144x^3y^2 \text{ and } 81xy^4$$

- b) Hence factorise completely this expression $144x^3y^2 - 81xy^4$ (2 marks)

2. The GCD of two numbers is 7 and their LCM is 140. If one of the numbers is 20, find the other number
(2mks)
3. The LCM of three numbers is 7920 and their GCD is 12. Two of the numbers are 48 and 264. Using factor notation find the third number if one of its factors is 9.
(3mks)
4. Find the least number of sweets that can be packed into polythene bags which contain either 9 or 15 or 20 or 24 sweets with none left over.
(3mks)
5. A number n is such that when it is divided by 27, 30, or 45, the remainder is always 3. Find the smallest value of n .
(2 mks)
6. A piece of land is to be divided into 20 acres or 24 acres or 28 acres for farming and leave 7 acres for grazing. Determine the smallest size of such land.
7. When a certain number x is divided by 30, 45 or 54, there is always a remainder of 21. Find the least value of the number x
8. A number m is such that when it is divided by 30, 36, and 45, the remainder is always 7. Find the smallest possible value of m .
9. Find the L.C.M of $x^2 + x$, $x^2 - 1$ and $x^2 - x$

1. Integers

1. The sum of two numbers exceeds their product by one. Their difference is equal to their product less five. Find the two numbers.
(3mks)
2. $3x - 1 > -4$
 $2x + 1 \leq 7$
3. Find the value of x
 $2^{(x-3)} \times 8^{(x+2)} = 128$

4. Evaluate $\frac{-12 \div (-3) \times 4 - (-15)}{-5 \times 6 \div 2 + (-5)}$
5. Without using a calculator/mathematical tables, evaluate leaving your answer as a simple fraction

$$\frac{(-4)(-2) + (-12) \div (+3)}{-9 - (-15)} + \frac{-20 + (+4) + (-6)}{46 - (8+2) - 3}$$
6. Given that $\mathbf{P} = \begin{pmatrix} -2 & 3 \\ -1 & 4 \end{pmatrix}$ and $\mathbf{R} = \begin{pmatrix} -1 & 3 \\ 0 & 2 \end{pmatrix}$ and if $\mathbf{Z} = \mathbf{P}^{-1}\mathbf{R}$. Find \mathbf{Z}
7. Evaluate $\frac{-8 \div 2 + 12 \times 9 - 4 \times 6}{56 \div 7 \times 2}$

2. Fractions

1. Simplify $\frac{125^{\frac{2}{3}} \div 3^4}{243^{-\frac{3}{5}}}$ (3 mks)
2. Simplify without using calculators and tables

$$\frac{5^{-\frac{1}{2}} \times 20^{\frac{1}{2}}}{64^{\frac{1}{2}} \times 3^0 \times 5^2}$$

(3mks)

3. Evaluate without using a calculator.

(3mks)

$$\frac{\left(1\frac{3}{7} - \frac{5}{8}\right) \times \frac{2}{3}}{\frac{3}{4} + 1\frac{5}{7} \div \frac{4}{7} \text{ of } 2\frac{1}{3}}$$

4. A two digit number is such that the sum of the ones and the tens digit is ten. If the digits are reversed, the new number formed exceeds the original number by 54.

Find the number.

(3

marks)

5. Evaluate $\frac{3}{8}$ of $\left\{7\frac{3}{5} - \frac{1}{3}\left(1\frac{1}{4} + 3\frac{1}{3}\right) \times 2\frac{2}{5}\right\}$

(3mks)

6. Convert the recurring decimal $12.\dot{1}\dot{8}$ into fraction

(3 mks)

7. Simplify $(0.00243)^{\frac{2}{5}} \times (0.0009)^{\frac{1}{2}}$ without using tables or calculator .

(3mks)

8. Evaluate without using tables or calculators

(4mks)

$$\frac{\frac{6}{7} \text{ of } \frac{14}{3} \div 80 \times -\frac{20}{3}}{-2 \times 5 + (14 \div 7) \times 3}$$

9. Mr. Saidi keeps turkeys and chickens. The number of turkeys exceeds the number of chickens by 6. During an outbreak of a disease, $\frac{1}{4}$ of the chicken and $\frac{1}{3}$ of the turkeys died. If he lost total of 30 birds, how many birds did he have altogether?

(2mks)

10. Work out $\frac{8 \div 2 + 12 \times 9 - 4 \times 6}{56 \div 7 \times 2}$

(2mks)

11. Evaluate -4 of $(-4 + -5 \div 15) + -3 - 4 \div 2)$

$$84 \div -7 + 3 - -5$$

12. (a) The recurring decimal $0.\dot{3}$ can be written as $\frac{3}{10} + \frac{3}{100} + \frac{3}{1000} + \dots$

(i) Find the common ratio.

(2mks)

(ii) Find an expression for the sum of n terms of this series.

(3mks)

(iii) Find the 8th term of the series.

(2mks)

(b) A ball is dropped from a height 30m above the ground and rebounds to $\frac{3}{4}$ of previous height continuously until it stops. Find the distance that the ball bounces when it hits the ground the 10th time. (Ans to 2 d.p).

(3mks)

13. Evaluate $\frac{\frac{5}{6} \text{ of } \left(4\frac{1}{3} - 3\frac{5}{6}\right)}{\frac{5}{12} \times \frac{3}{25} + 1\frac{5}{9} \div 2\frac{1}{3}}$ without using a calculator.

(3mks)

14. Without using tables or calculators evaluate.

END

$$\frac{35 \div 5 + 2 \times -3}{-9 + 14 \div 7 + 4}$$

(4mks)

15. Without using tables or calculator, evaluate the following. (2 mks)

$$\frac{-8 + (-13) \times 3 - (-5)}{-1 + (-6) \div 2 \times 2}$$

16. Without using tables or calculator evaluate (3 marks)

$$\frac{\sqrt[3]{13824} - 4}{3 + 4 \div 2 - 5 \times 7}$$

17. Express $1.\dot{9}\dot{3} + 0.\dot{2}\dot{5}$ as a single fraction (3 marks)

18. Simplify $\frac{1}{2}$ of $3\frac{1}{2} + 1\frac{1}{2} (2\frac{1}{2} - \frac{2}{3})$
 $\frac{3}{4}$ of $2\frac{1}{2} \div \frac{1}{2}$

19. Evaluate :
 $\frac{2}{5} \div \frac{1}{2}$ of $\frac{4}{9} - 1\frac{1}{10}$
 $\frac{1}{8} - \frac{1}{6}$ of $\frac{3}{8}$

20. Without using a calculator or table, work out the following leaving the answer as a mixed number in its simplest form:-

$$\frac{3}{4} + 1\frac{2}{7} \div \frac{3}{7} \text{ of } 2\frac{1}{3}$$

$$\left(\frac{9}{7} - \frac{3}{8}\right) \times \frac{2}{3}$$

21. Work out the following, giving the answer as a mixed number in its simplest form.
 $\frac{2}{5} \div \frac{1}{2}$ of $\frac{4}{9} - 1\frac{1}{10}$
 $\frac{1}{8} - \frac{1}{16} \times \frac{3}{8}$
22. Evaluate ;
 $\frac{3}{8}$ of $7\frac{3}{5} - \frac{1}{3}$ $1\frac{1}{4} + 3\frac{1}{3} \times 2\frac{2}{5}$
23. Without using a calculator, evaluate:
 $\frac{1^4}{5}$ of $\frac{25}{18} \div 1\frac{2}{3} \times 24$
 $2\frac{1}{3} - \frac{1}{4}$ of $12 \div \frac{5}{3}$ Leaving the answer as a fraction in its simplest form
24. There was a fund-raising in Matisi high school. One seventh of the money that was raised was used to construct a teacher's house and two thirds of the remaining money was used to construct classrooms. If shs.300,000 remained, how much money was raised

3. Decimals

1. Without using mathematical tables or calculators, evaluate: (3 mks)

$$\frac{0.0168 \times 2.46 \times 7}{5.74 \times 0.112}$$

2. A two-digit number is such that the sum of the ones digit and the tens digit is 10. If the digits are reversed, the number formed exceeds the original number by 54. Find the number (3 mks)
3. Without using tables and calculators, evaluate

$$\sqrt[3]{\frac{0.032 + 0.0608}{1.28 \times 0.4}}$$

(3mks)

4. Use a calculator to find;
 (a) 8754.3×53.84
 (b) $0.8341 + 8.72$

Hence find; $\sqrt[3]{\frac{8754.3 \times 53.84}{0.8341 + 8.72}}$

5. Express the recurring decimal below to a fraction 5.72 and leaving your answer in the form $\frac{a}{b}$ where **a** and **b** are whole numbers

6. Evaluate:- 0.38 x 0.23 x 2.7 without using tables or a calculator

7. Without using mathematical tables or calculator, evaluate:

$$\frac{0.084 \times 1.32 \times 3.5}{2.87 \times 0.056}$$

Leaving the answer as a fraction in its simplest form.

8. Find without using a calculator, the value of :

$$\frac{12 \sqrt{0.0625} - 12.4 \div 0.4 \times 3}{\frac{1}{8} \text{ of } 2.56 + 8.68}$$

4. Squares and square roots

1. Evaluate without using tables or calculators

$$\sqrt[3]{\frac{0.125 \times \sqrt{64}}{0.064 \times \sqrt{629}}}$$

(4mks)

2. Evaluate using reciprocals, square and square root tables only.

$$\sqrt{\frac{(445.1 \times 10^{-1})^2 + 1}{0.07245}}$$

(3mks)

3. Using a calculator, evaluate $\frac{\sqrt{(4.652 \times 0.387)^2}}{0.8462}$

(3mks)

(Show your working at each stage)

4. Use tables of reciprocals and square roots to evaluate

$$\sqrt{\frac{2}{0.5893} - \frac{1.06}{846.3}}$$

(3marks)

5. Use tables to find;

a) i) 4.978^2

ii) The reciprocal of 31.65

b) Hence evaluate to 4.S.F the value of

$$4.978^2 - \frac{1}{31.65}$$

6. Use tables of squares, square roots and reciprocals to evaluate correct to 4 s.f

$$\frac{3}{0.0136} - \frac{2}{(3.72)^2}$$

7. Without using mathematical tables or calculator, evaluate: $\sqrt{\frac{153 \times 1.8}{0.68 \times 0.32}}$ giving your answer in standard form

5. Algebraic expressions

- Simplify $\frac{3Z^2 - 12}{3 - (1 + Z)}$
(3mks)
- Five year ago, a mother's age was four times that of her daughter. In four years to come, she will be $2\frac{1}{2}$ times the age of her daughter. Calculate the sum of their present ages
- Mutua bought 160 trays of 8 eggs each at shs.150 per tray. On transportation 12 eggs broke. He later discovered that 20 eggs were rotten. If he sold the rest at shs.180 per tray, how much profit did he make?
- Simplify;
(a) $6a - 2b + 7a - 4b + 2$
(b) $\frac{2x-2}{2x} - \frac{3x+2}{4x}$
- Simplify $\frac{6x^2y^2 + 13xy - 5}{3x^2y^2 - 13xy + 4}$
- Given that $x + y = 8$ and $x^2 + y^2 = 24$
Find;
(a) the value of $x^2 + 2xy + y^2$
(b) Find the value of $2xy$
(c) $x^2 - 2xy + y^2$
(d) $x - y$
(e) Value of x and y
- Simplify the expression.
 $\frac{6x^2 + 35x - 6}{2x^2 - 72}$
- Simplify the expression
 $\frac{2}{3}(3x - 2) - \frac{3}{4}(2x - 2)$
- Simplify by factorizing completely:
 $\frac{4y^2 - x^2}{2x^2 - yx - 6y^2}$
- Simplify as far as possible.
 $\frac{3}{x - y} - \frac{1}{x + y}$

11. By calculation, find the coordinates of the intersection of the graphs $y = x^2 + 2x - 5$ and $y = 3x + 1$
12. Simplify:
 (a)
$$\frac{y^2 + 2y}{y^3 - y^2 - 6y} = \frac{1}{4}$$

 (b) hence solve:-
$$\frac{y^2 + 2y}{y^3 - y^2 - 6y} = \frac{1}{4}$$
13. A rectangular field measures 63.9m by 104.6metres find the minimum number of poles to be erected for fencing if they are to be at most 2.4meters apart.
14. Factorize completely the expression
 $75x^2 - 27y^2$
15. Every time an insect jumps forward the distance covered is half of the previous jump. If the insect initially jumped 8.4cm, calculate
 (i) To the nearest two decimal places distance of the sixth jump
 (ii) The total distance covered after the sixth jump
16. Simplify
$$\frac{P^3 - Pq^2 + P^2q - q^3}{P^2 + 2pq + q^2}$$
17. Simplify the expression:-
$$\frac{9x^2 - 4y^2}{12x^2 + yx - 6y^2}$$
18. Given that $(x-3)(Ax^2+bx+c) = x^3-7x-6$, find the value of A, B and C
19. a) solve for y in $8x(2^2)^y = 6x2^y - 1$
 b) Simplify completely
$$\frac{2x^2-98}{3x^2-16x-35} \div \frac{x+7}{3x+5}$$
20. Simplify the expression.:

$$\frac{4x^2 - y^2}{2x^2 - 7xy + 3y^2}$$
21. Simplify
$$\frac{P^2 - 2Pq + q^2}{P^3 - Pq^2 + P^2q - q^3}$$
22. The sum of two numbers is 15. The difference between five times the first number and three times the second number is 19. Find the two numbers
23. Simplify the following expressions by reducing it to a single fraction

$$\frac{2x-5}{4} - \frac{1-x}{3} - \frac{x-4}{2}$$

24. Simplify the expression:- $3a^2 + 4ab + b^2$
 $4a^2 + 3ab - b^2$

6. Rates, Ratio and percentages

1. Mary has 21 coins whose total value is shs 72. There are twice as many five shillings coins as there are ten shillings coins. The rest are one shilling coins. Find the number of ten shillings coins that Mary has.

(3mks)

2. (a) Divide 100cm^3 in the ratio $\frac{1}{4} : \frac{1}{2} : \frac{1}{5}$ to the nearest whole number.

(3mks)

- (b) In a chemistry experiment, a boy mixed some acid solution of 45% concentration with an acid solution of 25% concentration. In what proportion should the two acids be mixed in order to get 100cm^3 of solution of 30% concentration.

(3mks)

- (c) (i) Two blends of tea costing sh 140 and sh 160 per kg respectively are mixed in the proportion of 2:3 by mass. The mixture is then sold at sh 240 per kg. Find the gain percent

(2mks)

- (ii) In what ratio should the two blends be mixed to get a mixture that costs sh 148 per kg.

(2mks)

3. A cylindrical water tank is of diameter 14 metres and height 3.5 metres.

- (a) Find the capacity of the water tank in litre.

(3mks)

- (b) Six members of a family use 20 litres each per day. Each day 80 litre are used for cooking and washing. A further 50 litres is wasted daily. Find the number of complete days a full tank would last the family.

(3mks)

(c) Two members of the family were absent for 90 days. During this time, wasting was reduced by 20% as cooking and washing remained the same. Calculate the number of days a full tank would now last the family.

(4mks)

4. The length of a rectangle is increased by 20% while the width is decreased by 10%. Find the percentage change in area.

(2 mks)

5. (a) Divide 1000cm^3 in the ratio $\frac{1}{4} : \frac{1}{2} : \frac{1}{5}$, leaving your answer to the nearest 1 cm (3mks)

(b) In a Chemistry experiment, a boy mixed some acid solution of 45% concentration with an acid solution of 25% concentration. In what proportion should the two acids be mixed in order to get 100cm^3 of solution of 30% concentration? (3 mks)

(c) (i) Two blends of tea costing ksh. 140 and ksh. 160 per kilogram respectively are mixed in the proportion of 2:3 by mass. The mixture is sold at ksh. 240 per kilogram. Find the gain percent

(2 mks)

(ii) In what ratio should the two blends be mixed to get a mixture that costs ksh. 148 per kilogram

(2 mks)

6. Senjeni and Mkimwa entered into a business partnership in which they contributed ksh. 120,000 and ksh 150,000 every year respectively. After one year, Kuku joined the business and contributed ksh. 90,000.

(a) Calculate the ratio of their investment after 3 years of business

(3mks)

(b) It was agreed that 30% of the profits after 3 years be used to cater for the cost of running the business, while the remaining would be shared proportionally. Calculate each persons

share, if the profit made after three years was ksh. 187,000

(4mks)

(c) If each of them invested their shares back in the business, find their new individual

investments at the beginning of the fourth year

(3mks)

7. The population of elephants in Kenya's game reserves is 40,000 at present. If their population increase is estimated to be 30% every 10 years, calculate their population in 30 years time to the nearest 10.
(3mks)
8. Fifteen men working for eight hours a day can complete a certain job in exactly 24 days. For how many hours a day must sixteen men work in order to complete the same job in exactly 20 days.
(2mks)
9. Mwandime and Mwashuma working together do a piece of work in $\frac{22}{5}$ days. Mwandime working alone takes 2 days less than Mwashuma. How long does it take Mwashuma to do the work alone. (4 mks)
10. 20 women working four hours a day take 12 days to complete a job. If 8 of the women wish to do the same for 12 days, how many hours a day would they have to do work?
(2 marks)
11. If 5 men can erect 2 cottages in 21 days, how many more men, working at the same rate will be needed to erect 2 cottages in the same period?
12. The length and width of a rectangular paper were measured to the nearest centimeter and found to be 18cm and 12cm respectively. Find the percentage error in its perimeter in 6 hrs.
13. a) Two pipes **A** and **B** can fill a tank in 3hrs and 4 hrs respectively. Pipe **C** can empty the full tank
 - i) How long would it take pipes **A** and **B** to fill the tank if pipe **C** is closed?
 - ii) Starting with an empty tank, how long would it take to fill the tank with all pipes running?b) The high quality Kencoffee is a mixture of pure Arabica coffee and pure Robusta coffee in the ratio 1 : 3 by mass. Pure Arabica coffee costs shs. 180 per kg and pure Robusta coffee costs sh 120 per kg. Calculate the percentage profit when the coffee is sold at sh 162 per kg.
14. A number of nurses working at Sotik Health Centre decided to raise shs.144,000 to buy a plot of land. Each person was to contribute the same amount. Before the contributions were collected five of the nurses retired. This meant that the remaining contributors had to pay more to meet the target.

- (a) If there were n nurses originally, find the expression of the increase in contribution per person
- (b) If the increase in the contribution per person was shs.2,400, find the number of nurses originally at the health centre
- (c) How much would each person have contributed to nearest shilling if the 5 people had not retired
- (d) Calculate the percentage increase in the contribution per person because of the retirement

15. 3 taps **X**, **Y** and **Z** can fill a tank in 40 hours, 15 hours and 20 hours respectively. The three taps are turned on at 8.00a.m when the tank is empty for five hours then **Z** is turned off. After two hours tap **Y** is turned off. Work out ;-
- (a) The proportion of water in the tank after seven hours
- (b) The proportion of water in the tank after seven hours
- (c) The time the tank will be completely full
16. Jane and Philip working together can do a piece of work in 6 days. Jane working alone takes 5 days longer than Philip. How many days does it take Philip to do the work alone?
17. Sixteen men working 9 hours a day can complete a piece of work in 14 days. How many more men working 7 hours a day would complete the same job in 12 days?
18. A group of people planned to contribute equally towards buying land at a price of shs.180000. However 3 members of the group withdrew from the project. As a result, each of the remaining members were to contribute kshs.3000 more.
- (a) find the original number of members in the group
- (b) How much would each person have contributed if the 3 people had not withdrew
- (c) Calculate the percentage increase in the contribution per person caused by the withdrawal
19. Kori and Mue decided to start a business. Korir contributed shs.40,000 and Mue shs.64000.
- The two men agreed that in any year, 15% of the profit shall be divided equally between them and 20% of the profit will be used to meet the cost of running the business the following year.
- They also agreed to share the rest of the profit in the ratio of their contributions. The profit made after the first year was shs.43200.
- a) How much did they set aside towards the cost of running the business for the second year?*
- b) How much did Mue receive at the end of the first year?
- (c) Korir bought cows with his share of the profit. If each cow cost shs.1800, how many cows did he buy?

20. Given the ratio $x : y = 2:3$, find the ratio $(7x - 3y) : (2x + 3y)$
21. Abdul bought five bulls and thirty goats at an auction spending a total of Kshs.117000. His friend Ali bought four bulls and twenty five goats at the same auction and spent Kshs.22,250 less.
- (a) Find the cost of each animal at the auction
- (b) Abdul later sold all his animals at a profit of 40% per bull and 30% per goat. Ali sold all his animals at a profit of 50% per bull and 40% per goat. Determine who made more profit and by how much?
22. The cost of providing a commodity consists of transport, labour and raw material in the ratio 8:4:12 respectively. If the transport cost increases by 12% labour cost 18% and raw materials by 40%, find the percentage increase of producing the new commodity
23. A mother is now $2\frac{1}{2}$ times as old as her daughter Mary; four years ago the ratio of their ages was 3:1. Find the present age of the mother
24. Sixteen men working at the rate of 9hrs a day can complete a piece of work in 14 days. How many more men working at the rate of 7 hours a day would complete the same job in 12 days
25. Two business partners, Kago and Beatrice contributed 90, 000/= and 120,000/= in order to start a business. They agreed that 25% of the profit made after end of the year will be put back into the business. They also estimated that 40% of the profit will cover salaries and other expenses for the year. The remainder would be shared between the partners in the ratio of their contributions.
- At the end of the first year the business realized a gross profit of shs.181,300.
- a) Calculate how much each received after end of the year.
- b) At the end of 2nd year the business realized the same gross profit as the previous year and the partners decided to dissolve the business and share everything . Determine how much money each received.
26. A number is such that the product of its digits is 24. When the digits are reversed, the number so formed exceeds the original number by 27. Find the number
27. The radius of a cylinder is increased by 30% while its height is decreased by 20%. Find the percentage change in the volume of the cylinder

28. Tap **A** fills a tank in 6 hours, tap **B** fills it in 8 hours and tap **C** empties it in 10 hours. Starting with an empty tank and all the three taps are opened at the same time, how long will it take to fill the tank?
29. Sixteen men working 9 hours a day can complete a piece of work in 14 days. How many more men working 7 hours a day would complete the same job in 12 days?
30. Three businessmen Langat, Korir and Koech contributed shs.160,000, Shs.200,000 and shs.240,000 respectively and started a business. They agreed that 30% of the profit each year will go to expenses, 15% of the remainder would go back to the business. The rest of the profit would be shared in the ratio of their contribution. At the end of the first year, the business realized a profit of kshs.60,000. Calculate how much;
 (a) (i) Langat received
 (ii) Korir received
 (iii) Koech received
 (b) Express what Korir received as a percentage of the total profit
31. The price of a book is increased by 25%.
 (a) In what ratio has the price increased?
 (b) What is the new price if the book was shs.400 before the change?
32. (a) A chemist added 120 liters of a solution **A** containing 25% alcohol to 180 liters of solution **B** containing 20% alcohol. What percentage of the resulting solution is alcohol?
 (b) He removed **X** liters of resulting mixture and added an equal amount of pure alcohol to the resulting mixture. If the new mixture contains 22% of the alcohol, find the value of **X**
33. The length and width of a rectangular paper were measured to the nearest centimeter and found to be 18cm and 12cm respectively. Find the percentage error in its perimeter
34. Given that $a:b = 1:2$ and $b:c = 3:4$. Find $a:b:c$

7. length

1. Two coils which are made by winding copper wire of different gauges and length have the same mass. The first coil is made by winding 270 metres of wire with cross sectional diameter 2.8mm while the second coil is made by winding a certain length of wire with cross-sectional diameter 2.1mm. Find the length of wire in the second coil .
 (4 marks)
2. The figure below represents a model of a hut with $HG = GF = 10\text{cm}$ and $FB = 6\text{cm}$. The four slanting edges of the roof are each 12cm long.

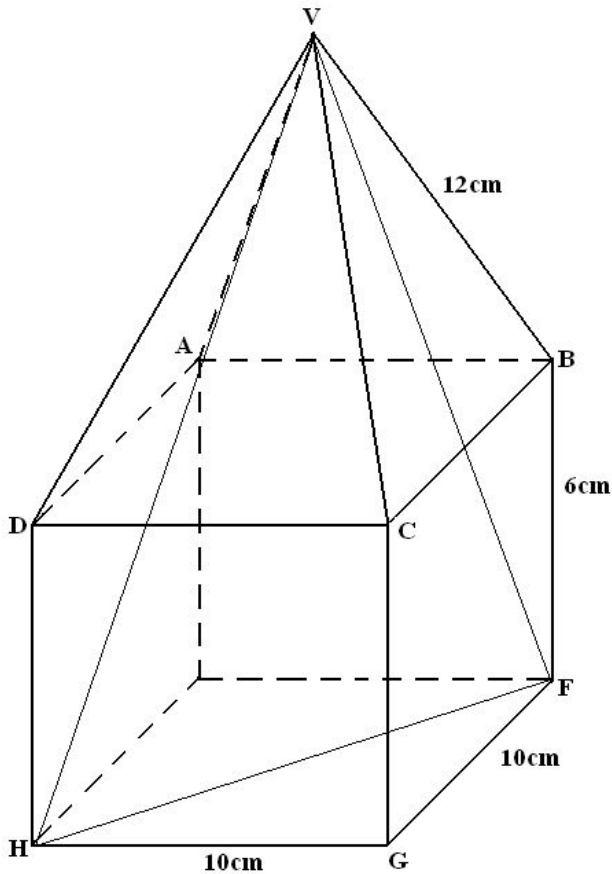

Calculate

- a. Length DF. (2 mks)
 - b. Angle VHF (2 mks)
 - c. The length of the projection of line VH on the plane EFGH. (1 mk)
 - d. The height of the model hut. (2 mks)
 - e. The length VH. (1 mk)
 - f. The angle DF makes with the plane ABCD. (2 mks)
3. A square floor is fitted with rectangular tiles of perimeter 220 cm. each row (tile length wise) carries 20 less tiles than each column (tiles breadth wise). If the length of the floor is 9.6 m.
Calculate:
- a. The dimensions of the tiles (6 marks)
 - b. The number of tiles needed (2 marks)
 - c. The cost of fitting the tiles, if tiles are sold in dozens at sh. 1500 per dozen and the labour cost is sh. 3000 (2 marks)
4. Simplify; by factorization:

$$\frac{15x^2 + xy - 6y^2}{5x^2 - 8xy + 3y^2}$$

5. Given the matrices $M = \begin{pmatrix} 3 & 0 \\ -1 & 4 \end{pmatrix}$, $R = \begin{pmatrix} -1 & 2 \\ 0 & 0 \end{pmatrix}$ and $N = \begin{pmatrix} 2/3 & 1 \\ 2 & 4 \end{pmatrix}$. Find the value of value of $3n + \frac{1}{2}(R-M)$

8. Area

1. Calculate the area of the shaded region below, given that AC is an arc of a circle centre B. $AB=BC=14\text{cm}$ $CD=8\text{cm}$ and angle $ABD = 75^\circ$ (4 mks)

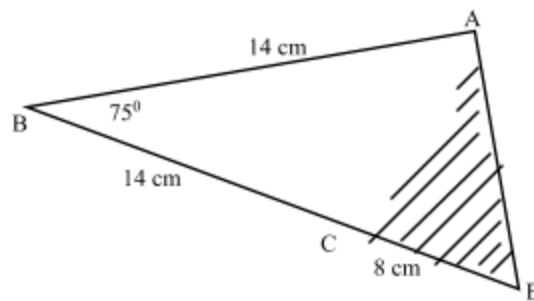

2. The scale of a map is 1:50000. A lake on the map is 6.16cm^2 . find the actual area of the lake in hactares.

(3mks)

3. The figure below is a rhombus ABCD of sides 4cm. BD is an arc of circle centre C. Given that $\angle ABC = 138^\circ$. Find the area of shaded region.

(3mks)

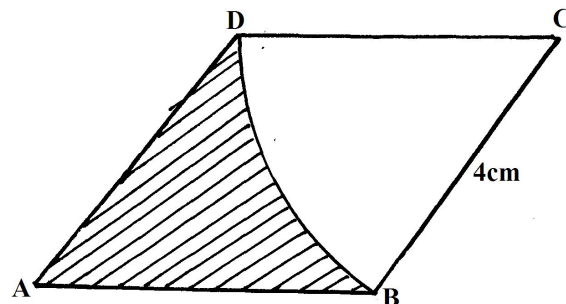

4. The figure below sows the shape of Kamau's farm with dimensions shown in meters

Find the area of Kamau's farm in hectares

(3mks)

5. In the figure below AB and AC are tangents to the circle centre O at B and C respectively, the angle $AOC = 60^\circ$

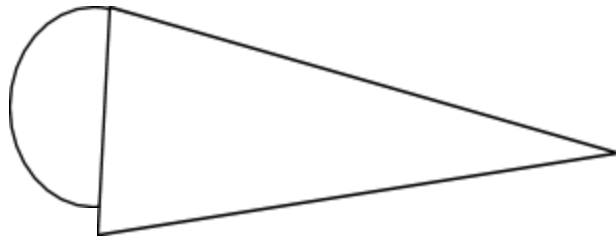

Calculate

- (a) The length of AC

(2 marks)

6. The figure below shows the floor of a hall. A part of this floor is in the shape of a rectangle of length 20m and width 16m and the rest is a segment of a circle of radius 12m. Use the figure to find:-

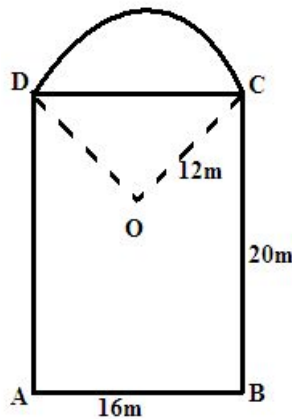

- (a) The size of angle COD

(2mks)

- (b) The area of figure DABCO

(4mks)

(c) Area of sector ODC

(2mks)

(d) Area of the floor of the house.

(2mks)

7. The circle below whose area is 18.05cm^2 circumscribes a triangle ABC where $AB = 6.3\text{cm}$, $BC = 5.7\text{cm}$ and $AC = 4.8\text{cm}$. Find the area of the shaded part

(4 mks)

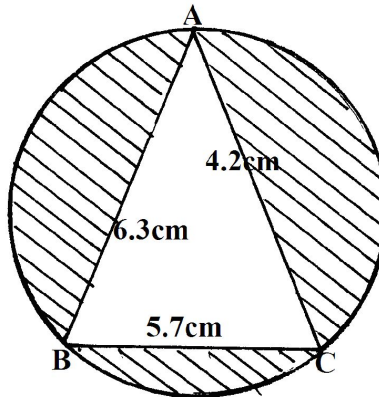

8. In the figure below, PQRS is a rectangle in which $PS = 10\text{k cm}$ and $PQ = 6\text{k cm}$. M and N are midpoints of QR and RS respectively

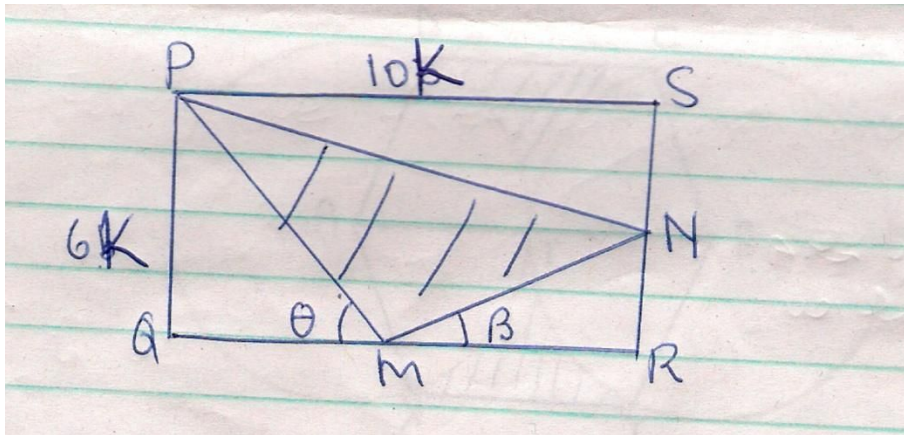

- a) Find the area of the shaded region (4 marks)
- b) Given that the area of the triangle $MNR = 30\text{ cm}^2$. find the dimensions of the rectangle (2 marks)
- c) Calculate the sizes of angles θ and β giving your answer to 2 decimal places (4 marks)
9. The figure below shows two circles each of radius 10.5 cm with centres A and B. the circles touch each other at T

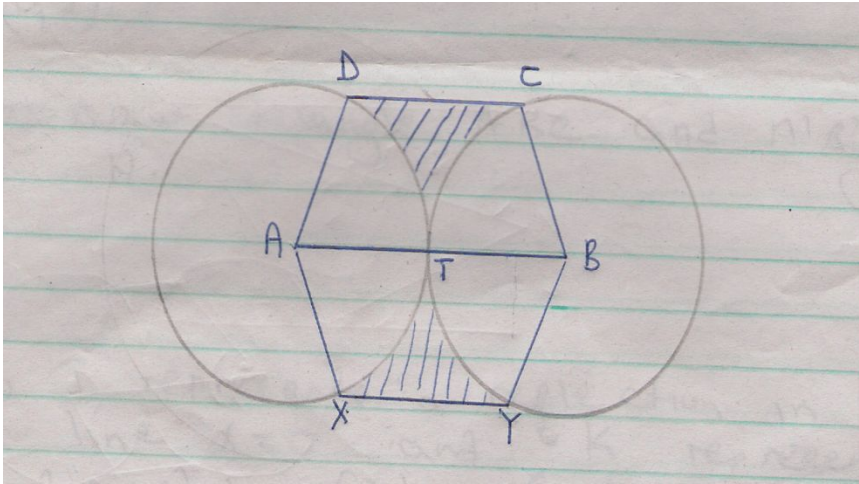

Given that angle $XAD = \text{angle } YBC = 160^\circ$ and lines XY , ATB and DC are parallel, calculate the area of:

- d) The minor sector $AXTD$ (2 marks)
 e) Figure $AXYBCD$ (6marks)
 f) The shaded region (2 marks)

10. A student took the measurements of his classroom and gave the width as 7m and the length as 9m.

If there is an error of 2% in each measurement, determine the greatest value of $\frac{x+y}{x}$

if x and y are the width and length of the classroom respectively.

Give your answer to 4 decimal places.

11. The floor of a room is in the shape of a rectangle 10.5 m long by 6 m wide. Square tiles of

length 30 cm are to be fitted onto the floor.

(a) Calculate the number of tiles needed for the floor.

(b) A dealer wishes to buy enough tiles for fifteen such rooms. The tiles are packed in cartons

each containing 20 tiles. The cost of each carton is Kshs. 800. Calculate

(i) the total cost of the tiles.

(ii) If in addition, the dealer spends Kshs. 2,000 and Kshs. 600 on transport and subsistence

respectively, at what price should he sell each carton in order to make a profit of 12.5%

(Give your answer to the nearest Kshs.)

12. The figure below is a circle of radius 5cm. Points **A**, **B** and **C** are the vertices of the triangle

ABC in which $\angle ABC = 60^\circ$ and $\angle ACB = 50^\circ$ which is in the circle. Calculate the area of ΔABC)

13. Mr. Wanyama has a plot that is in a triangular form. The plot measures 170m, 190m and 210m, but the altitudes of the plot as well as the angles are not known. Find the area of the plot in hectares
14. Three sirens wail at intervals of thirty minutes, fifty minutes and thirty five minutes. If they wail together at 7.18a.m on Monday, what time and day will they next wail together?
15. A farmer decides to put two-thirds of his farm under crops. Of this, he put a quarter under maize and four-fifths of the remainder under beans. The rest is planted with carrots. If 0.9acres are under carrots, find the total area of the farm
16. Find the area of the circle sector.

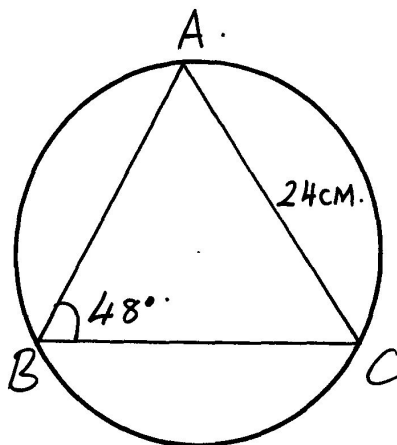

9. Volume and capacity

1. The figure below shows a bucket of depth 30cm used to fill a cylindrical tank of radius 1.2m and height 1.35m which is initially three-fifth full of water.

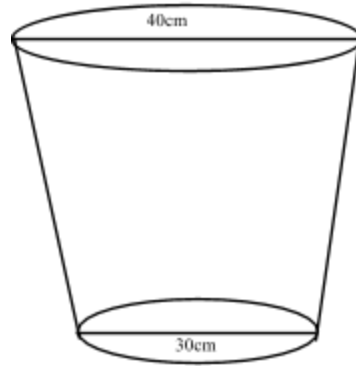

a) Calculate, in terms of π ;

(i) The capacity of the bucket in litres

(5mks)

(ii) The volume of water required to fill the tank in litres

(2mks)

(iii) Calculate the number of buckets that must be drawn to fill the tank

(3mks)

2. A bucket is in the shape of a frustum with base radius 12cm and top radius 16cm. The slant height of the bucket is 30cm as shown below. The bucket is full of water.

(a) Calculate the volume of the water. (Take $\pi = 3.142$)

(6

marks)

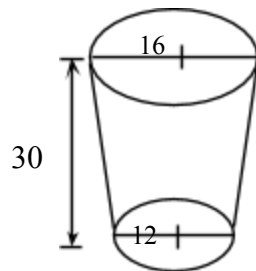

(b) All the water is poured into a cylindrical container of circular radius 12cm. If the cylinder has height 45cm, calculate the surface area of the cylinder which is not in contact with water. (4 marks)

3. The British government hired two planes to airlift football fans to South Africa for the World cup tournament. Each plane took $10 \frac{1}{2}$ hours to reach the destination.

Boeng 747 has carrying capacity of 300 people and consumes fuel at 120 litres per minute. It makes 5 trips at full capacity. Boeng 740 has carrying capacity of 140 people and consumes fuel at 200 litres per minute. It makes 8 trips at full capacity. If the government sponsored the fans one way at the cost of 800 dollars per fan, calculate:

(a) The total number of fans airlifted to South Africa.

(2mks)

(b) The total cost of fuel used if one litre costs 0.3 dollars.

(4mks)

(c) The total collection in dollars made by each plane.

(2mks)

(d) The net profit made by each plane.

(2mks)

4. The figure below represents a part in form of a frustum of a right circular cover. The upper and the lower radii are 50cm and 15cm respectively. The slant height is 70cm.

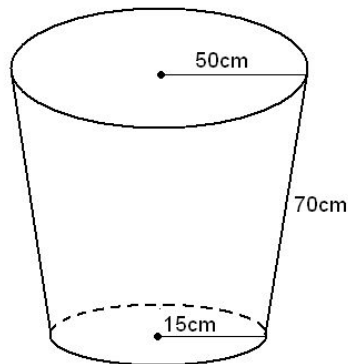

a. Calculate the height of the pail. (5 cm)

b. Find the capacity of the pail to the nearest a litre. (5 mks)

5. Consider the vessel below

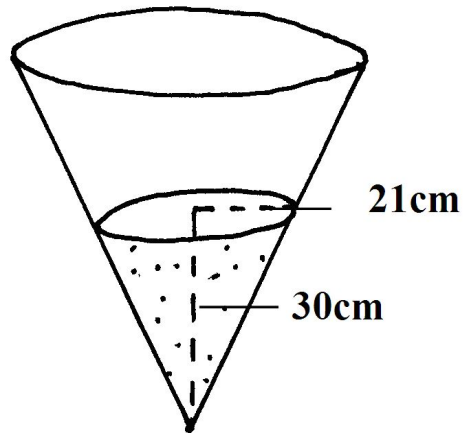

- a) Calculate the volume of water in the vessel.
- b) When a metallic hemisphere is completely submerged in the water, the level of the water rose by 6cm. Calculate:
- the radius of the new water surface.
 - the volume of the metallic hemisphere (to 4 s.f)
 - the diameter of the hemisphere (10 mks)
6. A village water tank is in the form of a frustrum of a cone of height 3.2m. The top and bottom radii are 18m and 24m respectively
- (a) Calculate:
- The surface area of the tank excluding the bottom
 - The capacity of the water tank
- (b) 15 families each having 15 members use the water tank and each person uses 65 litres of water daily. How long will it take for the full tank to be emptied
7. The diagram below shows a bucket with a top diameter 30cm and bottom diameter 20cm. The height of the bucket is 28cm
- (a) Calculate the capacity of the bucket in litres

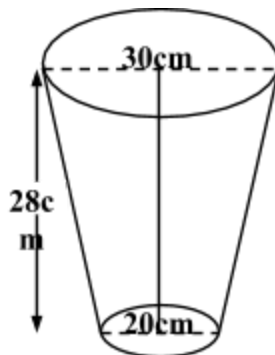

(b) Find the area of the metal sheet required to make 100 such buckets taking 10% extra for overlapping and wastage

8. A rectangular water tank measures 2.6m by 4.8m at the base and has water to a height of 3.2m. Find the volume of water in litres that is in the tank

9. The figure alongside shows a cone from which a frustum is made. A plane parallel to the base cuts the cone two thirds way up the vertical height of the cone to form frustum **ABCD**.

The top surface radius of the frustum is labeled **r** and the bottom radius is **R**

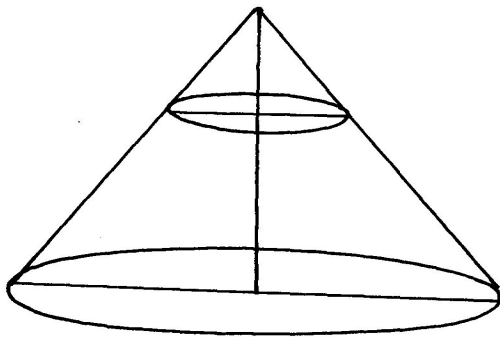

x r D

Y R C

a) Find the ratio $r:R$
 b) Given that $r = 7\text{cm}$, find R
 c) If the height VY of the original cone is 45cm, calculate to the nearest whole number the volume

of the frustum

d) The frustum represents a bucket which is used to fill a rectangular tank measuring 1.5m long, 1.2m wide and 80cm high with water. How many full buckets of water are required to fill the tank

10. Three litres of water (density 1g/cm^3) is added to twelve litres of alcohol (density 0.8g/cm^3).

What is the density of the mixture?

11. A rectangular tank whose internal dimensions are 2.2m by 1.4m by 1.7m is three fifth full of milk.

(a) Calculate the volume of milk in litres

(b) The milk is packed in small packets in the shape of a right pyramid with an equilateral base triangle of sides 10cm. The vertical height of each packet is 13.6cm. Full packets obtained are sold at shs.30 per packet. Calculate:

(i) The volume in cm^3 of each packet to the nearest whole number

- (ii) The number of full packets of milk
 - (iii) The amount of money realized from the sale of milk
12. An 890kg culvert is made of a hollow cylindrical material with outer radius of 76cm and an inner radius of 64cm. It crosses a road of width 3m, determine the density of the material used in its construction in Kg/m^3 correct to 1 decimal place.

10. Mass, weight and density

1. A squared brass plate is 2mm thick and has a mass of 1.05kg. The density of brass is 8.4g/cm^3 . Calculate the length of the plate in centimeters. (3mks)
2. A sphere has a surface area 18cm^2 . Find its density if the sphere has a mass of 100g. (3mks)
3. Nyahururu Municipal Council is to construct a floor of an open wholesale market whose area is 800m^2 . The floor is to be covered with a slab of uniform thickness of 200mm. In order to make the slab, sand, cement and ballast are to be mixed such that their masses are in the ratio 3:2:3. The mass of dry slab of volume 1m^3 is 2000kg. Calculate
- (a) (i) The volume of the slab (2mks)
 - (ii) The mass of the dry slab. (2mks)
 - (iii) The mass of cement to be used. (2mks)
 - (b) If one bag of the cement is 50kg, find the number of bags to be purchased. (1mk)
 - (c) If a lorry carries 10 tonnes of ballast, calculate the number of lorries of ballast to be purchased. (3mks)
4. A sphere has a surface area of 18.0cm^2 . Find its density if the sphere has a mass of 100 grammes.

(3 mks)

- A piece of metal has a volume of 20 cm^3 and a mass of 300g. Calculate the density of the metal in kg/m^3 .
- 2.5 litres of water density 1 g/cm^3 is added to 8 litres of alcohol density 0.8 g/cm^3 . Calculate the density of the mixture

11. Time

- A van travelled from Kitale to Kisumu a distance of 160km. The average speed of the van for the first 100km was 40km/h and the remaining part of the journey its average speed was 30km/h. Calculate the average speed for the whole journey.
(3 mks)
- A watch which loses a half-minute every hour was set to read the correct time at 0545h on Monday. Determine the time, in the 12 hour system, the watch will show on the following Friday at 1945h.
- A watch which loses a half-minute every hour was set to read the correct time at 0445h on Monday. Determine the time in 12-hour system, the watch will show on the following Friday at 1845h
- The timetable below shows the departure and arrival time for a bus plying between two towns **M** and **R**, 300km apart

Town	Arrival	Departure
M		0830h
N	1000h	1020h
P	1310h	1340h
Q	1510h	1520h
R	1600h	

- How long does the bus take to travel from town **M** to **R**?
- What is the average speed for the whole journey?

12.

Linear

1. Determine the inequalities that represent and satisfies the unshaded region (3 mks)

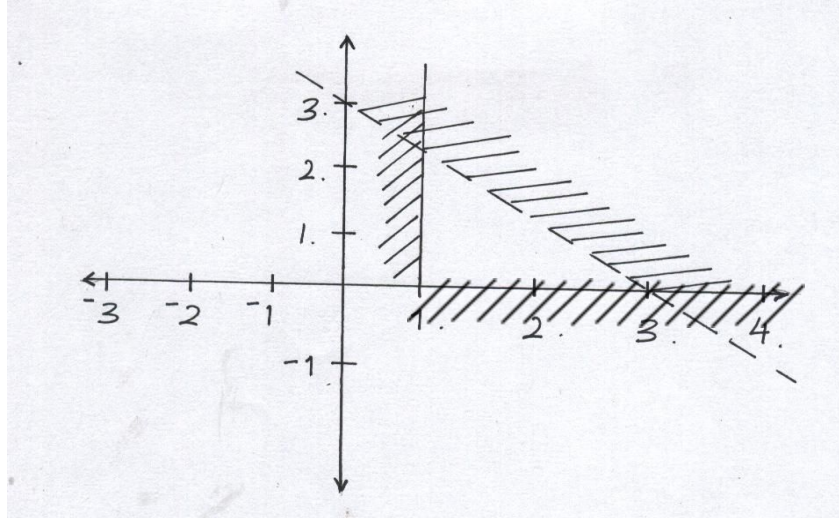

2. Write down the inequalities that satisfy the u shaded region in the figure below. (4mks)

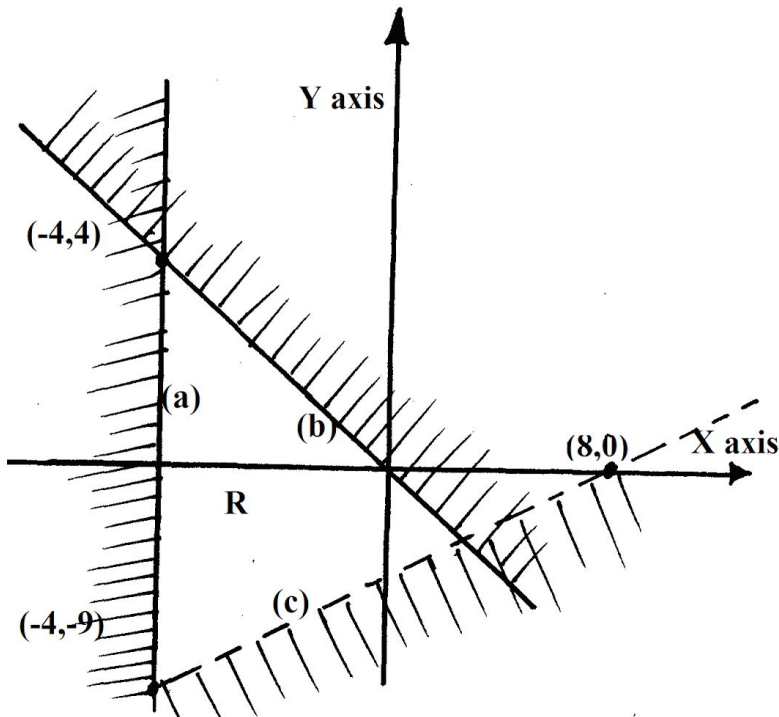

3. Find all integral values that satisfy the inequality $2x + 3 \geq 5x - 3 > -8$.

(3mks)

4. a) Find the range of values x which satisfied the following inequalities simultaneously.

(2 mks)

$$4x - 9 \leq 6 + x$$

$$8 - 3x \leq x + 4$$

b) Represent the range of values of x on a number line.

(1 mark)

5. Solve the inequality $-2x + 1 < x - 5 < 5 - x$

(2mks)

6. (a) Show by shading the unwanted region the area represented by

$4y < x + 11$, $x \geq 1$, $x + y \leq 9$ and $5y > 3x - 3$ on the grid provided

(8 mks)

(b) Calculate the area of the enclosed region (2 mks)

7. Solve the inequality below and write down the integral values that satisfy the equality $-3x + 2 < x + 6 \leq 17 - 2x$

(3 mks)

8. State all the integral values of a which satisfy the inequality

$$\frac{3a + 2}{4} \leq \frac{2a + 3}{5} \leq \frac{4a + 15}{6}$$

(3mks)

9. Solve the inequality $\frac{1}{2}x - 2 \leq 3x - 2 < 2 + \frac{1}{2}x$ and state the integral values which satisfy this inequalities. (3 marks)

10. Write down the inequalities that satisfy the given region simultaneously.

(3mks)

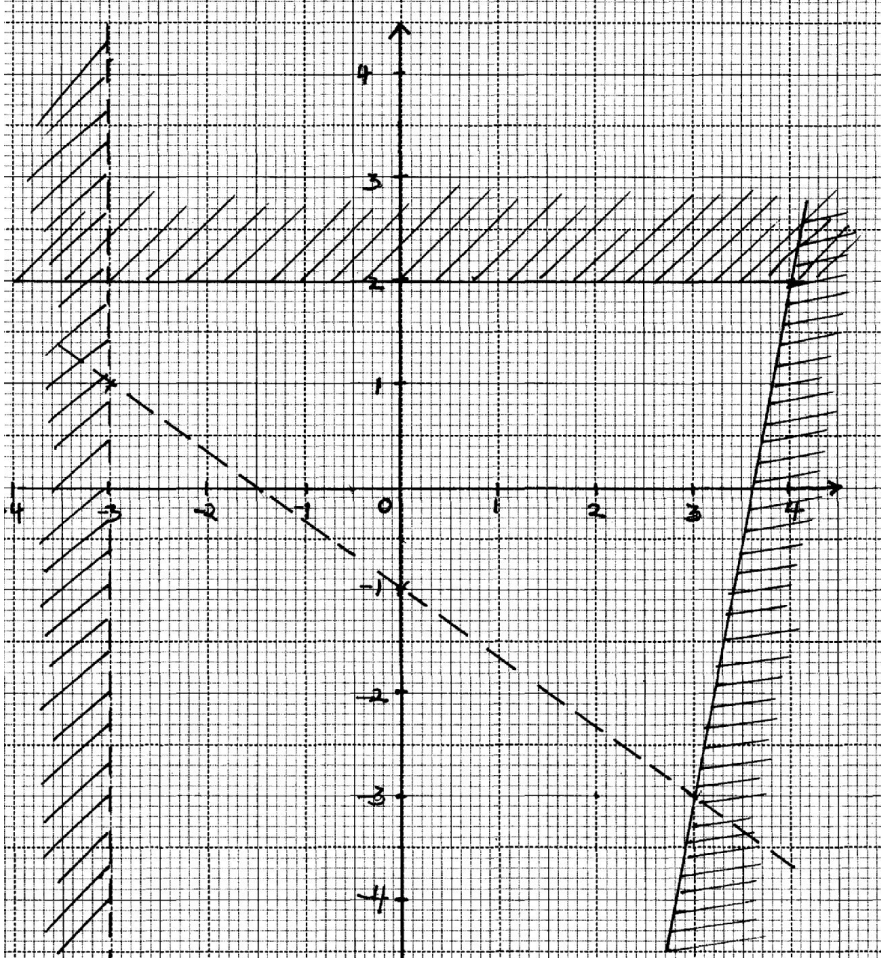

11. Write down the inequalities that define the unshaded region marked R in the figure below. (3mks)

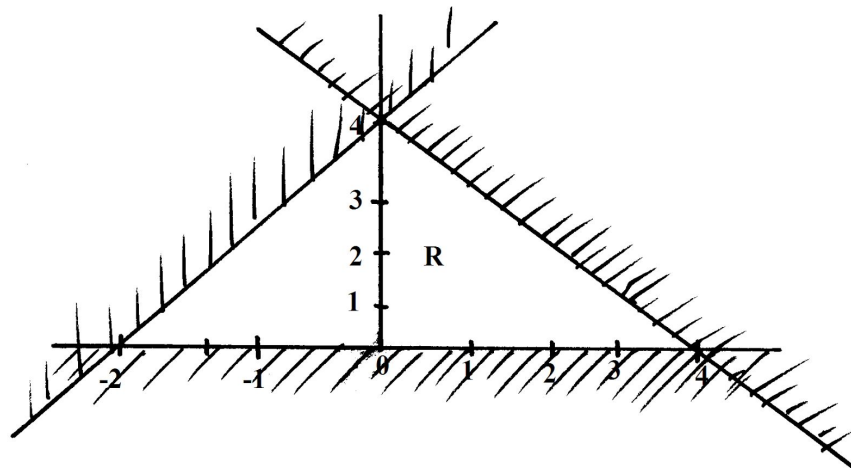

12. Write down all the inequalities represented by the regions R. (3mks)

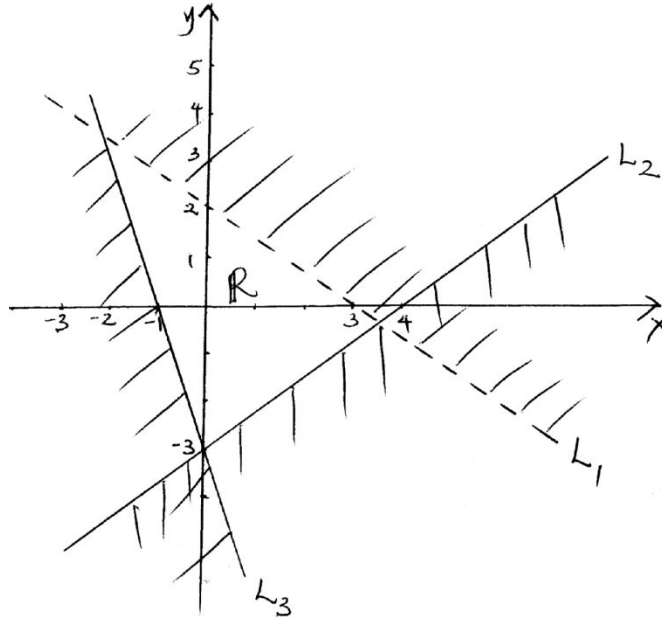

13. a) On the grid provided draw the graph of $y = 4 + 3x - x^2$ for the integral values of x in the interval $-2 \leq X \leq 5$. Use a scale of 2cm to represent 1 unit on the x – axis and 1

cm to represent 1 unit on the y – axis.

(6mks)

- b) State the turning point of the graph.

(1mk)

- c) Use your graph to solve.

(i) $-x^2 + 3x + 4 = 0$

(ii) $4x = x^2$

(3mks)

14. Solve the following inequality
marks)

(3

$$\frac{2x}{3} - 5.5 \leq 9.5 - \frac{3x}{4} \leq \frac{x}{3} + 18$$

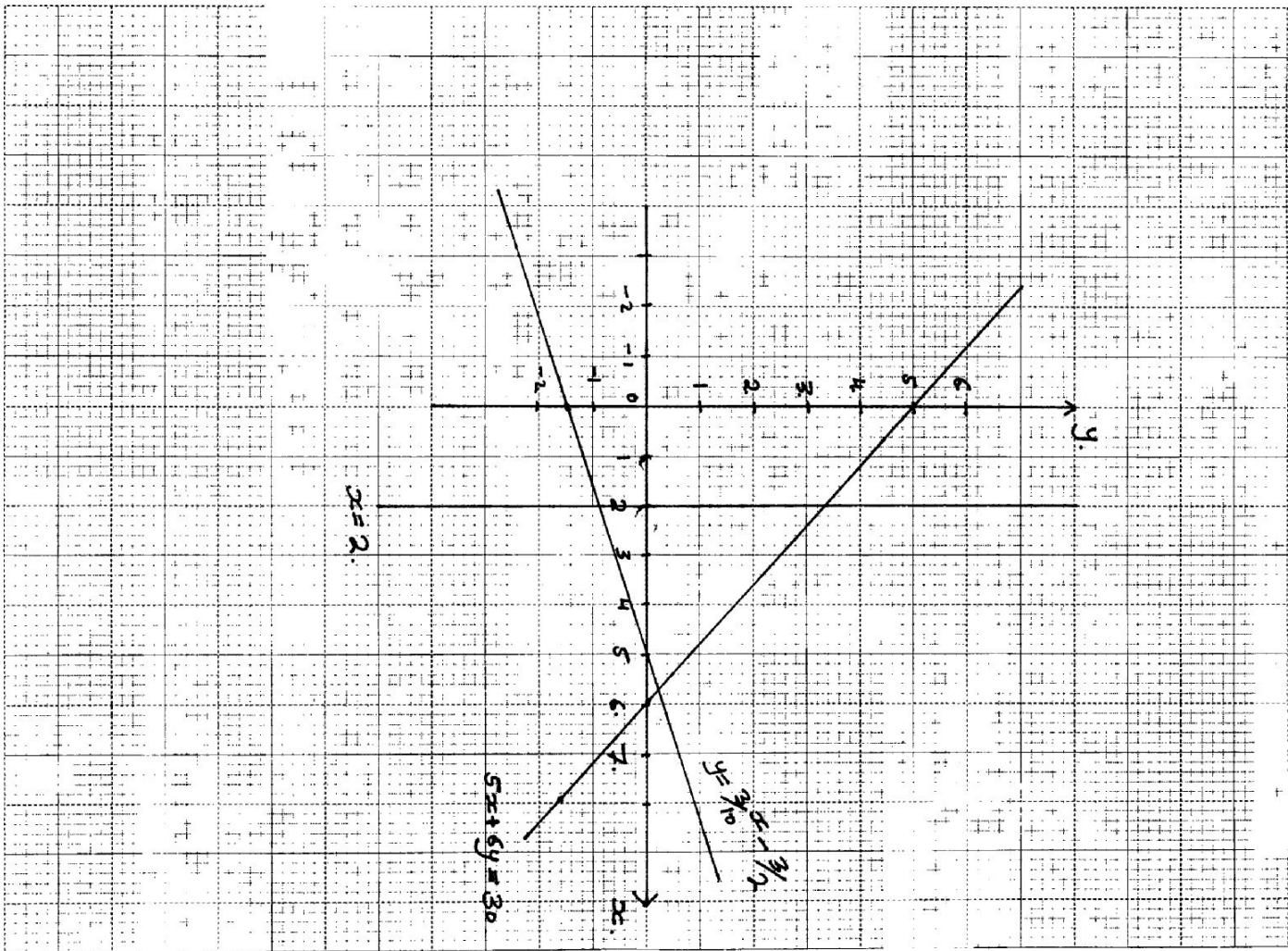

15. The diagram below shows the graphs of $y = \frac{3}{10}x - \frac{3}{2}$, $5x + 6y = 30$ and $x = 2$

By shading the unwanted region, determine and label the region **R** that satisfies the three inequalities; $y \geq \frac{3}{10}x - \frac{3}{2}$,
 $5x + 6y \geq 30$ and $x \geq 2$

16. The cost of 7 shirts and 3 pairs of trousers is shs. 2950 while that of 5 pairs of trousers and 3 shirts is less by 200. How much will Dan pay for 2 shirts and 2 pairs of trousers?
17. Mr. Wafula went to the supermarket and bought two biros and five pencils at sh.120. Whereas three biros and two pencils cost him sh.114. Find the cost of each biros and pencils
18. A father is twice as old as his son now. Ten years ago, the ratio of their ages was 5:2. Find their present ages
19. List the integral values of x which satisfy the inequalities below:-
 $2x + 21 \cdot 15 - 2x \geq x + 6$
20. Find the equation of a line which passes through (-1, -4) and is perpendicular to the line:-
 $y + 2x - 4 = 0$
21. John bought two shirts and three pairs of trousers at Kshs. 1750. If he had bought three shirts and two pairs of trousers, he would have saved Kshs. 250. Find the cost of a shirt and a trouser.
22. Express the recurring decimal 3.81 as an improper fraction and hence as a mixed number
23. Karani bought 4 pencils and 6 biro pens for shs.66 and Mary bought 2 pencils and 5 biro pens for shs.51

- (a) Find the price of each item
(b) Ondieki spent shs.228 to buy the same type of pencils and biro pens. If the number of biro pens he bought were 4 more than the number of pencils, find the number of pencils he bought
24. Two consecutive odd numbers are such that the difference of twice the larger number and twice the smaller number is 21. Find the product of the numbers
25. The size of an interior angle of a regular polygon is $3x^\circ$ while its exterior angle is $(x-20)^\circ$. Find the number of sides of the polygon
26. Five shirts and four pairs of trousers cost a total of shs.6160. Three similar shirts and a pair of trouser cost shs.2800. Find the cost of four shirts and two pairs of trousers
27. Two pairs of trousers and three shirts costs a total of Shs.390. Five such pairs of trousers and two shirts cost a total of Shs.810. Find the price of a pair of trouser and a shirt