

# MATHEMATICS

## FORM 3

### QUADRATIC EXPRESSION AND EQUATIONS

#### CHAPTER FOURTY FOUR

##### Specific Objectives

By the end of the topic the learner should be able to:

- (a) Factorize quadratic expressions;
- (b) Identify perfect squares;
- (c) Complete the square;
- (d) Solving quadratic equations by completing the square;
- (e) Derive the quadratic formula;
- (f) Solve quadratic equations using the formula;
- (g) Form and solve quadratic equations from roots and given situations;
- (h) Make tables of values from a quadratic relation;
- (i) Draw the graph of a quadratic relation;
- (j) Solve quadratic equations using graphs;
- (k) Solve simultaneous equations (one linear and one quadratic) analytically and graphically;
- (1) Apply the knowledge of quadratic equations to real life situations.

##### Content

- (a) Factorization of quadratic expressions

- (b) Perfect squares
- (c) Completion of the squares
- (d) Solution of quadratic equations by completing the square

(e) Quadratic formula  $x = \frac{-b \pm \sqrt{b^2 - 4ac}}{2a}$

- (f) Solution of quadratic equations using the formula.
- (g) Formation of quadratic equations and solving them
- (h) Tables of values for a given quadratic relation
- (i) Graphs of quadratic equations
- (j) Simultaneous equation - one linear and one quadratic
- (k) Application of quadratic equation to real life situation.

## Perfect square

Expressions which can be factorized into two equal factors are called perfect squares.

## Completing the square

Any quadratic expression can be simplified and written in the form  $ax^2 + bx + c$  where a, b and c are

constant and  $a$  is not equal to zero. We use the expression  $(\frac{b}{2})^2 = C$  to make a perfect square.

We are first going to look for expression where coefficient of  $x = 1$

### Example

What must be added to  $x^2 + 10x$  to make it a perfect square?

### Solution

- Let the number to be added be a constant  $c$ .
- Then  $x^2 + 10x + c$  is a perfect square.
- Using  $(\frac{b}{2})^2 = C$
- $(10/2)^2 = c$
- $C = 25$  (25 must be added)

### Example

What must be added to  $x^2 + \_ + 36$  to make it a perfect square

### Solution

- Let the term to be added be  $bx$  where  $b$  is a constant
- Then  $x^2 + bx + 36$  is a perfect square.
- Using  $(\frac{b}{2})^2 = 36$
- $\frac{b}{2} = \sqrt{36}$
- $\frac{b}{2} = \pm 6$      $b = 12x$  or  $-12x$

We will now consider the situations where  $a \neq 1$  and not equal to zero eg

$$4x^2 - 12x + 9 = (2x - 6)^2$$

$$9x^2 - 6x + 1 = (3x + 1)^2$$

In the above you will notice that  $(\frac{b}{2})^2 = ac$ . We use this expression to make perfect squares where  $a$  is not one and its not zero.

### Example

What must be added to  $25x^2 + \_ + 9$  to make it a perfect square?

### Solution

- Let the term to be added be  $bx$ .
- Then,  $25x^2 + bx + 9$  is a perfect square.
- Therefore  $(\frac{b}{2})^2 = 25 \times 9$ .
- $(\frac{b}{2})^2 = 225$
- $\frac{b}{2} = \pm 15$
- so  $b = 30$  or  $-30$  The term to be added is thus  $30x$  or  $-30x$ .

### Example

What must be added to  $\_ - 40x + 25$  to make it a perfect square?

### Solution

- Let the term to be added be  $ax^2$
- Then  $ax^2 - 40x + 25$  is a perfect square.
- Using  $(\frac{b}{2})^2 = ac$
- $(\frac{-40}{2})^2 = 25a$
- $400 = 25a$
- $a = 16$  the term to be added is  $16x^2$

Solutions of quadratic equations by completing the square methods

Example



Solve  $x^2 + 5x + 1 = 0$  by completing the square.

**solution**

$$x^2 + 5x + 1 = 0 \quad \text{Write original equation.}$$

$$x^2 + 5x = -1 \quad \text{Write the left side in the form } x^2 + bx.$$

$$x^2 + 10x + \left(\frac{5}{2}\right)^2 = \left(\frac{5}{2}\right)^2 - 1 \quad \text{Add } \left(\frac{5}{2}\right)^2 \text{ to both sides}$$

$$x^2 + 10x + \frac{25}{4} = \frac{21}{4}$$

$$\left(x + \frac{5}{2}\right)^2 = \frac{21}{4} \quad \text{Take square roots of each side and factorize the left side}$$

$$x + \frac{5}{2} = \pm \sqrt{\frac{21}{4}} \quad \text{Solve for } x.$$

$$= -\frac{5}{2} \pm \frac{4.583}{2} \quad \text{Simplify}$$

$$= -\frac{0.417}{2} \text{ or } \frac{9.583}{2} \quad \text{Therefore } x = -0.2085 \text{ or } 4.792$$

The method of completing the square enables us to solve quadratic equations which cannot be solved by factorization.

**Example**

Solve  $2x^2 + 4x + 1 = 0$  by completing the square

**Solution**

$$2x^2 + 4x = -1 \quad \text{make coefficient of } x^2 \text{ one by dividing both sides by 2}$$

$$x^2 + 2x = -1/2$$

$$x^2 + 2x + 1 = -\frac{1}{2} + 1$$

**Adding 1 to complete the square on the LHS**

$$(x + 1)^2 = \frac{1}{2}$$

$$x + 1 = \pm \sqrt{\frac{1}{2}}$$

$$x = -1 \pm \sqrt{0.5}$$

$$= -1 \pm 0.7071$$

$$x = 0.2929 \text{ or } -1.7071$$

The quadratic formula

$$\frac{-b \pm \sqrt{b^2 - 4ac}}{2a}$$

### Example

Using quadratic formula solve  $2x^2 - 5x - 3 = 0$

### Solution

Comparing this equation to the general equation  $ax^2 + bx + c = 0$  we get;  $a = 2$   $b = -5$   $c = -3$

Substituting in the quadratic formulae

$$x = \frac{-b \pm \sqrt{b^2 - 4ac}}{2a}$$

$$= \frac{-(-5) \pm \sqrt{(-5)^2 - 4(2)(-3)}}{2(2)}$$

$$= \frac{5 \pm \sqrt{49}}{4}$$

$$= \frac{5 \pm 7}{4}$$

$$= \frac{12}{4} \text{ or } \frac{-2}{4}$$

$$x = 3 \text{ or } -\frac{1}{2}$$

### Formation of quadratic equations

Peter travels to his uncle's home, 30 km away from his place. He travels for two thirds of the journey before the bicycle developed mechanical problems and he had to push it for the rest of the journey. If his cycling speed is 10 km/h faster than his walking speed and he completes the journey in 3 hours 30 minutes, determine his cycling speed.

### Solution

Let Peter's cycling speed be  $x$  km/h, then his walking speed is  $(x - 10)$  km/h.

$$\text{Time taken in cycling} = \left(\frac{2}{3} \text{ of } 30\right) \div x$$

$$= \frac{20}{x} \text{ h}$$

$$\text{Time taken in walking} = (30 - 20) \div (x - 10)$$

$$= \frac{10}{x-10} \text{ h}$$

$$\text{Total time} = \left(\frac{20}{x} + \frac{10}{x+10}\right) \text{ h}$$

$$\text{Therefore } \left(\frac{20}{x} + \frac{10}{x-10}\right) = 3\frac{1}{3}$$

$$\left(\frac{20}{x} + \frac{10}{x-10}\right) = \frac{10}{3}$$

$$60(x-10) + 30(x) = 10(x)(x-10)$$

$$10x^2 - 190x + 600 = 0$$

$$x^2 - 19x + 60 = 0$$

$$x = \frac{19 \pm \sqrt{361-240}}{2}$$

$$x = 15 \text{ or } 4$$

If his cycling speed is 4 km/h, then his walking speed is (4 - 10) km/h, which gives - 6 km/h. Thus, 4 is not a realistic answer to this situation. therefore his cycling speed is 15 km/h.

### Example

A positive two digit number is such that the product of the digit is 24. When the digits are reversed, the number formed is greater than the original number by 18. Find the number

### Solution

Let the ones digit of the number be y and the tens digit be x,

Then,  $xy = 24$ .....1

When the number is reversed, the ones digit is x and the tens digit is y.

Therefore;

$$(10y + x) - (10x + y) = 18$$

$$9y - 9x = 18$$

$$y - x = 2 \quad y = x + 2 \dots\dots\dots 2$$

Substituting 2 in equation 1 gives;

$$x(x+2) = 24$$

$$x^2 + 2x - 24 = 0$$

$$x = \frac{-2 \pm \sqrt{4^2 - 96}}{2}$$

$$x = 4 \text{ or } -6$$

Since the required number is positive  $x = 4$  and  $y = 4 + 2 = 6$

Therefore the number is 46

## Graphs of quadratic functions

A quadratic function has the form  $y = ax^2 + bx + c$  where  $a \neq 0$ . The graph of a quadratic function is U-shaped and is called a parabola. For instance, the graphs of  $y = x^2$  and  $y = -x^2$  are shown below. The origin  $(0, 0)$  is the lowest point on the graph of  $y = x^2$  and the highest point on the graph of  $y = -x^2$ . The lowest or highest point on the graph of a quadratic function is called the vertex. The graphs of  $y = x^2$  and  $y = -x^2$  are symmetric about the  $y$ -axis, called the *axis of symmetry*. In general, the axis of symmetry for the graph of a quadratic function is the vertical line through the vertex..

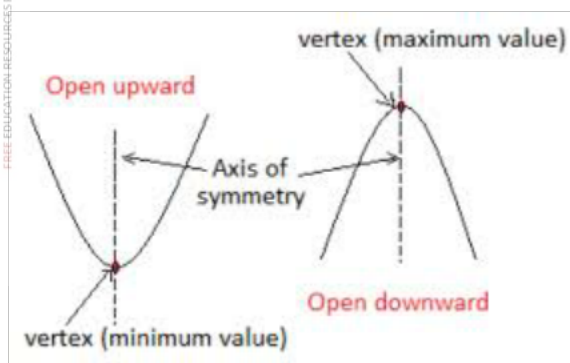

Notes;

The graph of  $y=x^2$  faces downwards or open upwards and  $y=-x^2$  faces upwards or open downwards.

### Example

Draw the graph of  $y=-2x^2 + 5x - 1$

### Solution

Make a table showing corresponding value of  $x$  and  $y$ .

X	-1	0	1	2	3	
Y	-8	-1	2	1	-4	

Note ; To get the values replace the value of  $x$  in the equation to get the corresponding value of  $y$

$$E. g \ y = -2(-1)^2 + 5(-1) - 1 = -8$$

$$y = -2(0)^2 + 5(0) - 1 = -1$$

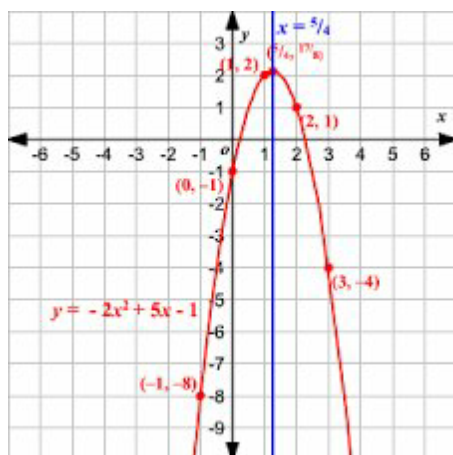

### Example

Draw the graph of  $y = x^2 - 7x + 2$

x	0	1	2	3	5	7
y	2	-4	-8	-10	-8	2

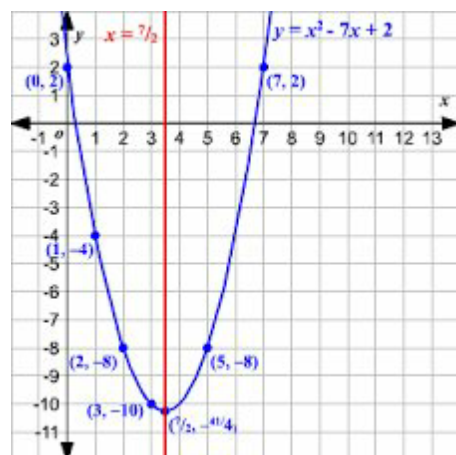

## Graphical solutions of simultaneous equations

We should consider simultaneous equation one of which is linear and the other one is quadratic.

### Example

Solve the following simultaneous equations graphically:

$$y = x^2 - 2x + 1$$

$$y = x^2 - 2x$$

### Solution

Corresponding values of x and y

x	-2	-1	0	1	2	3	4	x
y	9	4	1	0	1	4	9	y

We use the table to draw the graph as shown below, on the same axis the line  $y = 5-2x$  is drawn. Points where the line  $y = 5 - 2x$  and the curve  $y = x^2 - 2x + 1$  intersect give the solution. The points are  $(- 2, 9)$  and  $(2,1)$ . Therefore, when  $x = -2, y = 9$  and when  $x = 2, y = 1$

End of topic

Did you understand everything?

If not ask a teacher, friends or anybody and make sure you understand before going to sleep!

## Past KCSE Questions on the topic.

1. The table shows the height metres of an object thrown vertically upwards varies with the time  $t$  seconds

The relationship between  $s$  and  $t$  is represented by the equations  $s = at^2 + bt + 10$  where  $a$  and  $b$  are constants.

t	0	1	2	3	4	5	6	7	8	9	10
s		45.1									

- (a) (i) Using the information in the table, determine the values of  $a$  and  $b$  (2 marks)
- (ii) Complete the table (1 mark)
- (b)(i) Draw a graph to represent the relationship between  $s$  and  $t$  (3 marks)
- (ii) Using the graph determine the velocity of the object when  $t = 5$  seconds
2. (a) Construct a table of value for the function  $y = x^2 - x - 6$  for  $-3 \leq x \leq 4$
- (b) On the graph paper draw the graph of the function  $Y = x^2 - x - 6$  for  $-3 \leq x \leq 4$
- (c) By drawing a suitable line on the same grid estimate the roots of the equation  $x^2 + 2x - 2 = 0$
3. (a) Draw the graph of  $y = 6 + x - x^2$ , taking integral value of  $x$  in  $-4 \leq x \leq 5$ . (The grid is provided. Using the same axes draw the graph of  $y = 2 - 2x$
- (b) From your graphs, find the values of  $X$  which satisfy the simultaneous equations  $y = 6 + x - x^2$   
 $y = 2 - 2x$

- (c) Write down and simplify a quadratic equation which is satisfied by the values of  $x$  where the two graphs intersect.

4. (a) Complete the following table for the equation  $y = x^3 - 5x^2 + 2x + 9$

$x$	-2	-1.5	-1	0	1	2	3	4	5
$x^2$		-3.4	-1	0	1		27	64	125
$-5x^2$	-20	-11.3	-5	0	-1	-20	-45		
$2x$	-4	-3		0	2	4	6	8	10
9	9	9	9	9	9	9	9	9	99
		-8.7			9	7		-3	

(b) On the grid provided draw the graph of  $y = x^3 - 5x^2 + 2x + 9$  for  $-2 \leq x \leq 5$

(c) Using the graph estimate the root of the equation  $x^3 - 5x^2 + 2x + 9 = 0$  between  $x = 2$  and  $x = 3$

(d) Using the same axes draw the graph of  $y = 4 - 4x$  and estimate a solution to the equation  $x^2 - 5x^2 + 6x + 5 = 0$

5. (a) Complete the table below, for function  $y = 2x^2 + 4x - 3$

$x$	-4	-3	-2	-1	0	1	2
$2x^2$	32		8	2	0	2	
$4x - 3$			-11		-3		5
$y$			-3			3	13

(b) On the grid provided, draw the graph of the function  $y = 2x^2 + 4x - 3$  for

$-4 \leq x \leq 2$  and use the graph to estimate the roots of the equation  $2x^2 + 4x - 3 = 0$  to 1 decimal place. (2mks)

(c) In order to solve graphically the equation  $2x^2 + x - 5 = 0$ , a straight line must be drawn to intersect the curve  $y = 2x^2 + 4x - 3$ . Determine the equation of this straight line, draw the straight line hence obtain the roots.

$2x^2 + x - 5$  to 1 decimal place.

6. (a) (i) Complete the table below for the function  $y = x^3 + x^2 - 2x$  (2mks)

$x$	-3	-2.5	-2	-1.5	-1	-0.5	0	0.5	1	2	2.5
$x^3$		15.63				-0.13			1		
$x^2$			4					0.25			6.25
$-2x$						1			-2		



y				1.87				0.63			16.88
---	--	--	--	------	--	--	--	------	--	--	-------

(ii) On the grid provided, draw the graph of  $y = x^3 + x^2 - 2x$  for the values of  $x$  in the interval  $-3 \leq x \leq 2.5$

(iii) State the range of negative values of  $x$  for which  $y$  is also negative

(b) Find the coordinates of two points on the curve other than  $(0, 0)$  at which  $x$ - coordinate and  $y$ - coordinate are equal

7. The table shows some corresponding values of  $x$  and  $y$  for the curve represented by  $Y = \frac{1}{4} x^3 - 2$

X	-3	-2	-1	0	1	2	3
Y	-8.8	-4	-2.3	-2	-1.8	0	4.8

On the grid provided below, draw the graph of  $y = \frac{1}{4} x^2 - 2$  for  $-3 \leq x \leq 3$ . Use the graph to estimate the value of  $x$  when  $y = 2$

8. A retailer planned to buy some computers from a wholesaler for a total of Kshs 1,800,000. Before the retailer could buy the computers the price per unit was reduced by Kshs 4,000. This reduction in price enabled the retailer to buy five more computers using the same amount of money as originally planned.

(a) Determine the number of computers the retailer bought

(b) Two of the computers purchased got damaged while in store, the rest were sold and the retailer made a 15% profit Calculate the profit made by the retailer on each computer sold

9. The figure below is a sketch of the graph of the quadratic function  $y = k$

$(x+1)(x-2)$

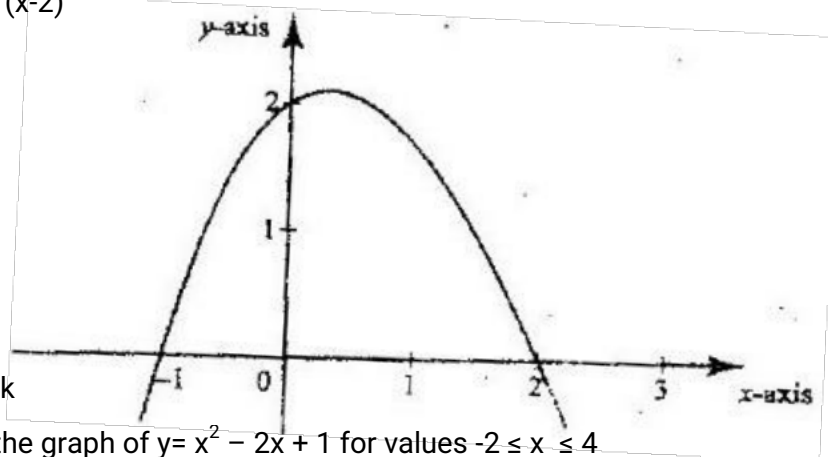

Find the value of  $k$

10. (a) Draw the graph of  $y = x^2 - 2x + 1$  for values  $-2 \leq x \leq 4$

(b) Use the graph to solve the equations  $x^2 - 4 = 0$  and line  $y = 2x + 5$

11. (a) Draw the graph of  $y = x^3 + x^2 - 2x$  for  $-3 \leq x \leq 3$  take scale of 2cm to represent 5 units as the horizontal axis

(b) Use the graph to solve  $x^3 + x^2 - 6 - 4 = 0$  by drawing a suitable linear graph on the same axes.

12. Solve graphically the simultaneous equations  $3x - 2y = 5$  and  $5x + y = 17$

## CHAPTER FOURTY TWO

### APPROXIMATION AND ERROR

#### Specific Objectives

By the end of the topic the learner should be able to:

- Perform various computations using a calculator;
- Make reasonable approximations and estimations of quantities in computations and measurements;
- Express values to a given number of significant figures;
- Define absolute, relative, percentage, round-off and truncation errors;
- Determine possible errors made from computations;
- Find maximum and minimum errors from operations.

#### Content

- Computing using calculators
- Estimations and approximations
- Significant figures
- Absolute, relative, percentage, round-off (including significant figures) and truncation errors
- Propagation of errors from simple calculations
- Maximum and minimum errors.

### Approximation

Approximation involves rounding off and truncating numbers to give an estimation

#### Rounding off

In rounding off the place value to which a number is to be rounded off must be stated. The digit occupying the next lower place value is considered. The number is rounded up if the digit is greater or equal to 5 and rounded down if it's less than 5.

### Example

Round off 395.184 to:

- The nearest hundreds
- Four significant figures
- The nearest whole number
- Two decimal places

### Solution

- 400
- 395.2
- 395
- 395.18

## Truncating

Truncating means cutting off numbers to the given decimal places or significant figures, ignoring the rest.

### Example

Truncate 3.2465 to

- 3 decimal places
- 3 significant figures

### Solution

- 3.246
- 3.24

## Estimation

Estimation involves rounding off numbers in order to carry out a calculation faster to get an approximate answer. This acts as a useful check on the actual answer.

### Example

Estimate the answer to  $\frac{152 \times 269}{32}$

### Solution

The answer should be close to  $\frac{150 \times 270}{30} = 1350$

The exact answer is 1277.75. 1277.75 written to 2 significant figures is 1300 which is close to the estimated answer.

## ACCURACY AND ERROR

### Absolute error

The absolute error of a stated measurement is half of the least unit of measurement used. When a measurement is stated as 3.6 cm to the nearest millimeter, it lies between 3.55 cm and 3.65 cm. The least unit of measurement is millimeter, or 0.1 cm. The greatest possible error is  $3.55 - 3.6 = -0.05$  or  $3.65 - 3.6 = +0.05$ .

To get the absolute error we ignore the sign. So the absolute error is 0.05 thus,  $|-0.05| = |+0.05| = 0.05$ . When a measurement is stated as 2.348 cm to the nearest thousandths of a centimeters (0.001) then the absolute error is  $\frac{1}{2} \times 0.001 = 0.0005$ .

### Relative error

$$\text{Relative error} = \frac{\text{absolute}}{\text{actual measurements}}$$

#### Example

An error of 0.5 kg was found when measuring the mass of a bull. If the actual mass of the bull was found to be 200 kg. Find the relative error.

#### Solution

$$\text{Relative error} = \frac{\text{absolute}}{\text{actual measurements}} = \frac{0.5}{200} \text{ kg} = 0.0025$$

### Percentage error

Percentage error = relative error x 100%

$$= \frac{\text{absolute error}}{\text{actual measurement}} \times 100\%$$

#### Example

The thickness of a coin is 0.20 cm.

- The percentage error
- What would be the percentage error if the thickness was stated as 0.2 cm ?

#### Solution

The smallest unit of measurement is 0.01

$$\text{Absolute error} = \frac{1}{2} \times 0.01 = 0.005$$

$$\text{Percentage error} = \frac{0.005}{0.20} \times 100\%$$

$$= 2.5 \%$$

The smallest unit of measurement is 0.1

$$\text{Absolute error} = \frac{1}{2} \times 0.1 = 0.05 \text{ cm}$$

$$\text{Percentage error} = \frac{0.05}{0.2} \times 100\%$$

$$= 25 \%$$

## Rounding off and truncating errors

An error found when a number is rounded off to the desired number of decimal places or significant figures,

for example when a recurring decimal 1.6 is rounded to the 2 significant figures, it becomes 1.7 the rounded off error is;

$$1.7 - 1.6 = \frac{17}{10} - \frac{5}{3} = \frac{1}{30}$$

**Note;**

1.6 converted to a fraction  $\frac{5}{3}$ .

## Truncating error

The error introduced due to truncating is called a truncation error. in the case of 1.6 truncated to 2 S.F., the

$$\text{truncated error is; } |1.6 - 1.6| = |1\frac{6}{10} - 1\frac{2}{3}| = \frac{1}{15}$$

## Propagation of errors

### Addition and subtraction

What is the error in the sum of 4.5 cm and 6.1 cm, if each represent a measure measurement.

**Solution**

The limits within which the measurements lie are 4.45, i.e. , 4.55 or  $4.5 \pm 0.005$  and 6.05 to 6.15, i.e.  $6.1 \pm 0.05$ .

The maximum possible sum is  $4.55 + 6.15 = 10.7\text{cm}$

The minimum possible sum is  $4.45 + 6.05 = 10.5\text{ cm}$

The working sum is  $4.5 + 6.1 = 10.6$

The absolute error = maximum sum – working sum

$$= |10.7 - 10.6|$$

$$= 0.10$$

### Example

What is the error in the difference between the measurements 0.72 g and 0.31 g?

### Solution

The measurement lie within  $0.72 \pm 0.005$  and  $0.31 \pm 0.005$  respectively the maximum possible difference will be obtained if we subtract the minimum value of the second measurement from the maximum value of the first, i.e ;

$$0.725 - 0.305\text{ cm}$$

The minimum possible difference is  $0.715 - 0.315 = 0.400$ .the working difference is  $0.72 - 0.31 = 0.41$ , which has an absolute error of  $|0.420 - 0.41|$  or  $|0.400 - 0.41| = 0.01$ . Since our working difference is 0.41, we give the absolute error as 0.01 (to 2 s.f)

### Note:

In both addition and subtraction, the absolute error in the answer is equal to the sum of the absolute errors in the original measurements.

## Multiplication

### Example

A rectangular card measures 5.3 cm by 2.5 cm. find

- The absolute error in the rea of the card
- The relative error in the area of the cord

### Solution

- The length lies within the limits  $5.3 \pm 0.05\text{ cm}$
- The length lies within the limits  $2.5 \pm 0.05\text{ cm}$

The maximum possible area is  $2.55 \times 5.35 = 13.6425\text{ cm}^2$

The minimum possible area is  $2.45 \times 5.25 = 12.8625\text{ cm}^2$

The working area is  $5.3 \times 2.5 = 13.25\text{ cm}^2$

Maximum area – working area =  $13.6425 - 13.25 = 0.3925$ .

Working area – minimum area =  $13.25 - 12.8625 = 0.3875$

We take the absolute error as the average of the two.

$$\begin{aligned} \text{Thus, absolute error} &= \frac{0.3925 + 0.3875}{2} \\ &= 0.3900 \end{aligned}$$

The same can also be found by taking half the interval between the maximum area and the minimum area

$$\frac{1}{2}(13.6425 - 12.8625) = 0.39$$

The relative error in the area is :

$$\frac{0.39}{13.25} = 0.039 \quad (\text{to 2 S.F})$$

## Division

Given  $8.6 \text{ cm} \div 3.4 \text{ cm}$ . Find:

- The absolute error in the quotient
- The relative error in the quotient

## Solution

- $8.6 \text{ cm}$  has limits  $8.55 \text{ cm}$  and  $8.65 \text{ cm}$ .  $3.4$  has limits  $3.35 \text{ cm}$  and  $3.45 \text{ cm}$ . The maximum possible quotient will be given by the maximum possible value of the numerator and the smallest possible value of the denominator, i.e.,

$$\frac{8.65}{3.35} = 2.58 \quad (\text{to 3 s.f})$$

The minimum possible quotient will be given by the minimum possible value of the numerator and the biggest possible value of the denominator, i.e.

$$\frac{8.55}{3.45} = 2.48 \quad (\text{to 3 s.f})$$

The working quotient is;  $\frac{8.6}{3.4} = 2.53 \quad (\text{to 3 .f.})$

The absolute error in the quotient is;

$$\frac{2.53 \times 2.48}{2} = \frac{1}{2} \times 0.10$$



$$= 0.050 \text{ ( to 2 s.f)}$$

b. Relative error in the working quotient ;

$$\frac{0.05}{2.53} = \frac{5}{253}$$

$$= 0.0197$$

$$= 0.020 \text{ (to 2 s.f)}$$

### Alternatively

Relative error in the numerator is  $\frac{0.05}{8.6} = 0.00581$

Relative error in the denominator is  $\frac{0.05}{3.4} = 0.0147$

Sum of the relative errors in the numerator and denominator is

$$0.00581 + 0.0147 = 0.02051$$

$$= 0.021 \text{ to 2 S.F}$$

End of topic

Did you understand everything?

If not ask a teacher, friends or anybody and make sure you understand before going to sleep!

## Past KCSE Questions on the topic.

1. (a) Work out the exact value of  $R = \frac{1}{0.003146 - 0.003130}$
- (b) An approximate value of  $R$  may be obtained by first correcting each of the decimal in the denominator to 5 decimal places
  - (i) The approximate value
  - (ii) The error introduced by the approximation
2. The radius of circle is given as 2.8 cm to 2 significant figures
  - (a) If  $C$  is the circumference of the circle, determine the limits between which  $\frac{C}{\pi}$  lies
  - (b) By taking  $\pi$  to be 3.142, find, to 4 significant figures the line between which the circumference

lies.

3. The length and breadth of a rectangular floor were measured and found to be 4.1 m and 2.2 m respectively. If possible error of 0.01 m was made in each of the measurements, find the:
- Maximum and minimum possible area of the floor
  - Maximum possible wastage in carpet ordered to cover the whole floor

4. In this question Mathematical Tables should not be used

The base and perpendicular height of a triangle measured to the nearest centimeter are 6 cm and 4 cm respectively.

Find

- The absolute error in calculating the area of the triangle
  - The percentage error in the area, giving the answer to 1 decimal place
5. By correcting each number to one significant figure, approximate the value of  $788 \times 0.006$ . Hence calculate the percentage error arising from this approximation.
6. A rectangular block has a square base whose side is exactly 8 cm. Its height measured to the nearest millimeter is 3.1 cm
- Find in cubic centimeters, the greatest possible error in calculating its volume.
7. Find the limits within the area of a parallelogram whose base is 8cm and height is 5 cm lies. Hence find the relative error in the area
8. Find the minimum possible perimeter of a regular pentagon whose side is 15.0cm.
9. Given the number 0.237
- Round off to two significant figures and find the round off error
  - Truncate to two significant figures and find the truncation error
10. The measurements  $a = 6.3$ ,  $b = 15.8$ ,  $c = 14.2$  and  $d = 0.00173$  have maximum possible errors of 1%, 2%, 3% and 4% respectively. Find the maximum possible percentage error in  $\frac{ad}{bc}$  correct to 1sf.

## CHAPTER FOURTY THREE

# TRIGONOMETRY

### Specific Objectives

By the end of the topic the learner should be able to:

- (a) Define and draw the unit circle;
- (b) Use the unit circle to find trigonometric ratios in terms of co-ordinates of points for  $0 < \theta < 360^\circ$ ;
- (c) Find trigonometric ratios of negative angles;
- (d) Find trigonometric ratios of angles greater than  $360^\circ$  using the unit circle;
- (e) Use mathematical tables and calculators to find trigonometric ratios of angles in the range  $0 < \theta < 360^\circ$ ;
- (f) Define radian measure;
- (g) Draw graphs of trigonometric functions;  $y = \sin x$ ,  $y = \cos x$  and  $y = \tan x$  using degrees and radians;
- (h) Derive the sine rule;
- (i) Derive the cosine rule;
- (j) Apply the sine and cosine rule to solve triangles (sides, angles and area),
- (k) Apply the knowledge of sine and cosine rules in real life situations.

### Content

- (a) The unit circles
- (b) Trigonometric ratios from the unit circle
- (c) Trigonometric ratios of angles greater than  $360^\circ$  and negative angles
- (d) Use of trigonometric tables and calculations
- (e) Radian measure

- (f) Simple trigonometric graphs
- (g) Derivation of sine and cosine rule
- (h) Solution of triangles
- (i) Application of sine and cosine rule to real situation.

### The unit circle

It is circle of unit radius and centre O (0, 0).

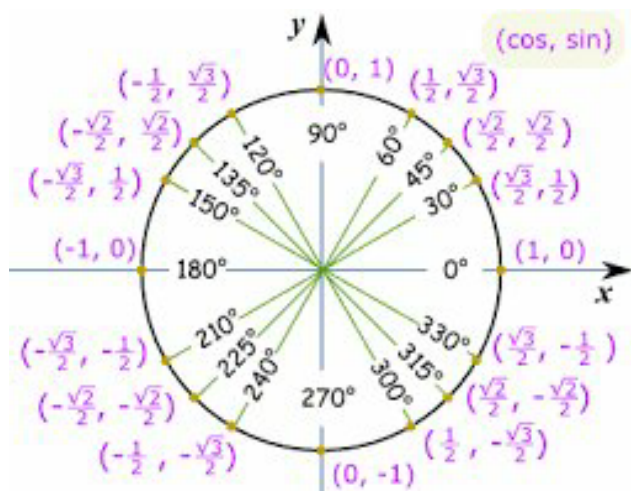

From  $0^\circ - 90^\circ$  is the first quadrant

isabokemicah@gmail.com

From  $90^{\circ}$  -  $180^{\circ}$  is the second quadrant

From  $180^{\circ}$  -  $270^{\circ}$  is the third quadrant

From  $270^{\circ}$  -  $360^{\circ}$  is the fourth quadrant

An angle measured anticlockwise from positive direction of x – axis is positive. While an angle measured clockwise from negative direction of x – axis is negative.

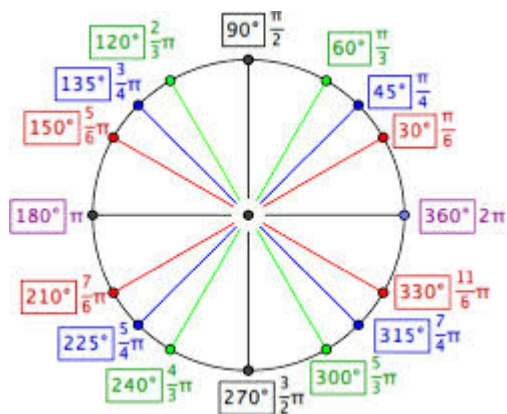

In general, on a unit circle

- I.  $\cos \theta^{\circ} = x$  co - ordinate of p.
- II.  $\sin \theta^{\circ} = y$  co - ordinate of p.
- III.  $\tan \theta^{\circ} = \frac{y \text{ co-ordinate of p}}{x \text{ co-ordinate of p}} = \frac{\sin \theta}{\cos \theta}$

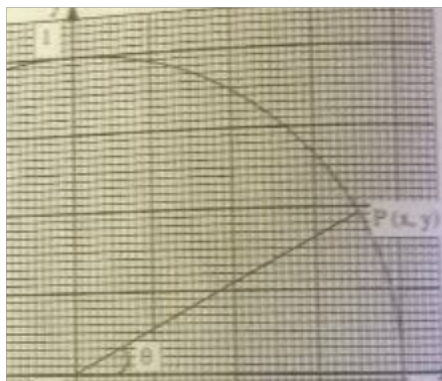

## Trigonometric ratios of negative angles

In general

I.  $\sin(-\theta) = -\sin\theta$

II.  $\cos(-\theta) = \cos\theta$

III.  $\tan(-\theta) = -\tan\theta$

# The Unit Circle

Positive: sin, csc  
Negative: cos, tan, sec, cot

Positive: sin, cos, tan, sec, csc, cot  
Negative: none

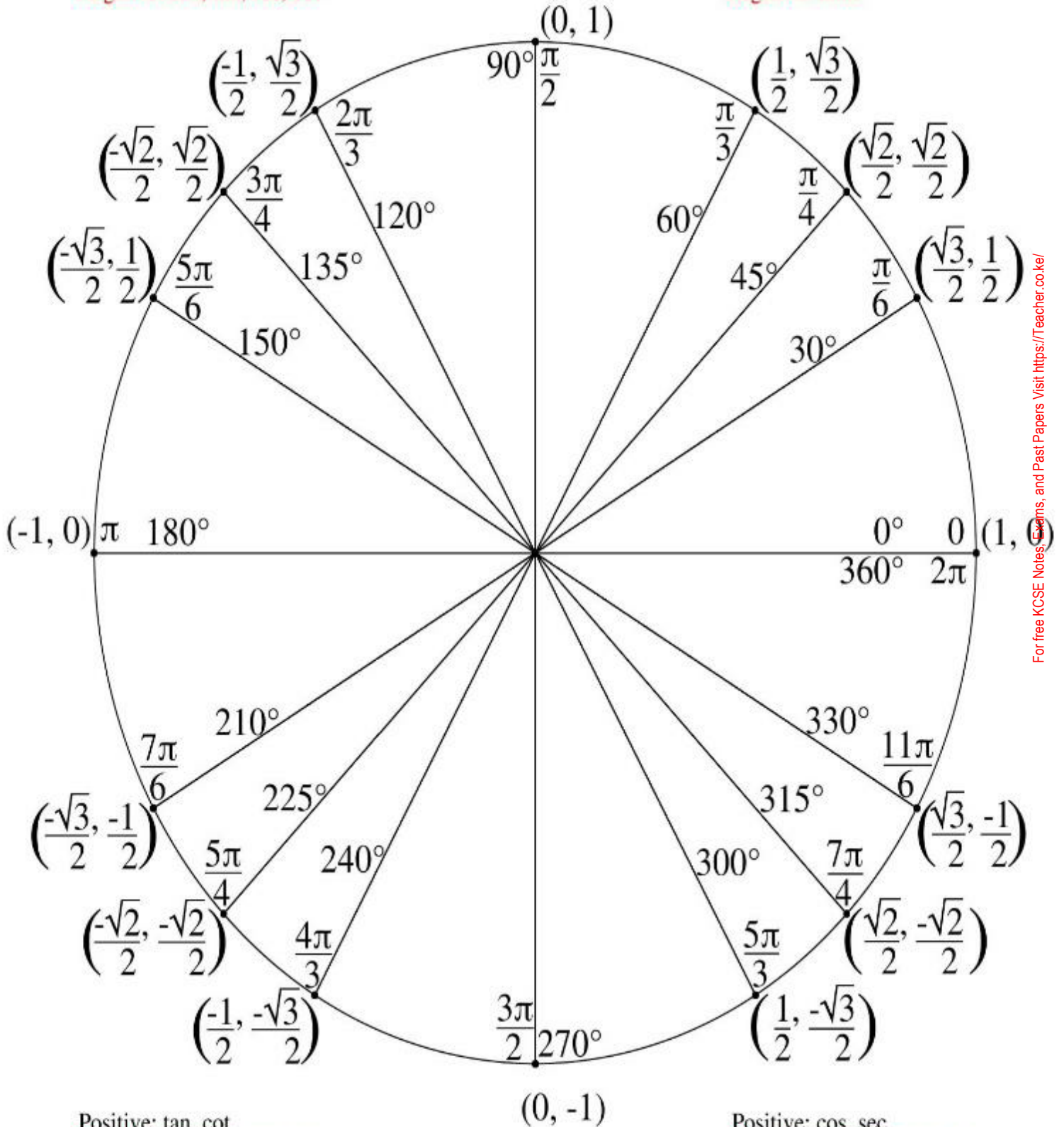

For free KCSE Notes, Exams, and Past Papers Visit <https://Teacher.co.ke/>

Positive: tan, cot  
Negative: sin, cos, sec, csc

Positive: cos, sec  
Negative: sin, tan, csc, cot

## Use of calculators

### Example

Use a calculator to find

I.  $\tan 30^\circ$

### Solution

- Key in tan
- Key in 30
- Screen displays 0.5773502
- Therefore  $\tan 30^\circ = 0.5774$

To find the inverse of sine cosine and tangent

- Key in shift
- Then either sine cosine or tangent
- Key in the number

### Note;

Always consult the manual for your calculator. Because calculators work differently

## Radians

One radian is the measure of an angle subtended at the centre by an arc equal in length to the radius of the circle.

Because the circumference of a circle is  $2\pi r$ , there are  $2\pi$  radians in a full circle. Degree measure and radian measure are therefore related by the equation  $360^\circ = 2\pi$  radians, or  $180^\circ = \pi$  radians.

The diagram shows equivalent radian and degree measures for special angles from  $0^\circ$  to  $360^\circ$  (0 radians to  $2\pi$  radians). You may find it helpful to memorize the equivalent degree and radian measures of special angles in the first quadrant. All other special angles are just multiples of these angles.

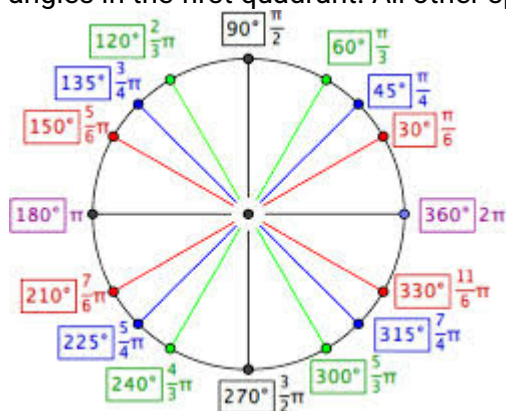

### Example

Convert  $125^\circ$  into radians



**Solution**

$$\text{If } 1^\circ = \frac{360^\circ}{2\pi} = 57.29$$

$$\text{Therefore } 125^\circ = \frac{125}{57.29} = 2.182 \text{ to 4 S.F}$$

**Example**

Convert the following degrees to radians, giving your answer in terms  $\pi$ .

$$60^\circ$$

**Solution**

$$360^\circ = 2\pi^\circ$$

Therefore

$$60^\circ = \left(\frac{2\pi}{360} \times 60\right)^\circ$$

$$= \left(\frac{\pi}{3}\right)^\circ$$

**Example**

What is the length of the arc that subtends an angle of 0.6 radians at the centre of a circle of radius 20 cm.

**Solution**

$1^\circ$  is subtended by 20 cm

therefore  $0.6^\circ$  is subtended by  $20 \times 0.6 \text{ cm} = 12 \text{ cm}$

Simple trigonometric graphs

Graphs of  $y = \sin x$

The graphs can be drawn by choosing a suitable value of  $x$  and plotting the values of  $y$  against the corresponding values of  $x$ .

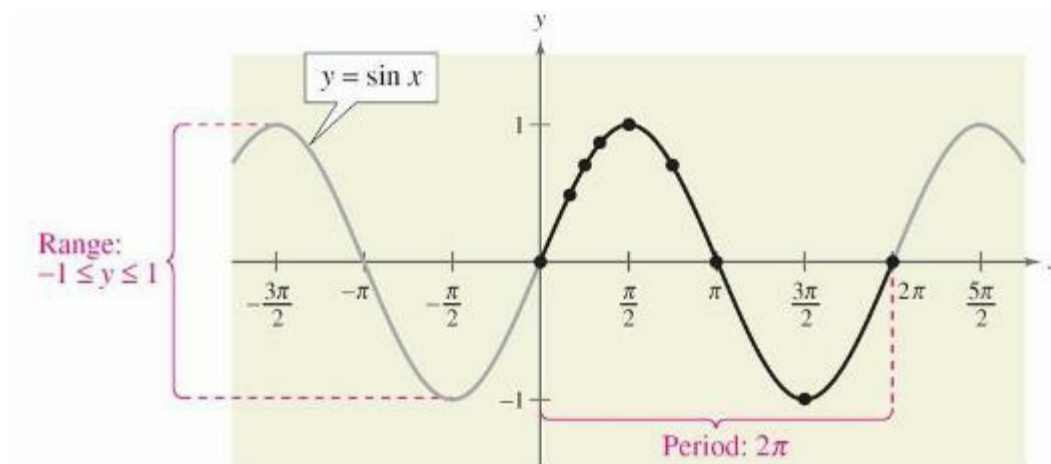

The black portion of the graph represents one period of the function and is called **one cycle** of the sine curve.

**Example**

Sketch the graph of  $y = 2 \sin x$  on the interval  $[-\pi, 4\pi]$ .

**Solution:**

Note that  $y = 2 \sin x = 2(\sin x)$  indicates that the  $y$ -values for the key points will have twice the magnitude of those on the graph of  $y = \sin x$ .

x	$\pi/2$	$\pi$	$3\pi$	$2\pi$
$Y=2\sin x$	2	0	-2	0

To get the values of  $y$  substitute the values of  $x$  in the equation  $y = 2\sin x$  as follows

$y = 2 \sin (360)$  because  $2 \pi$  is equal to  $360^\circ$

**Note;**

- You can change the radians into degrees to make work simpler.
- By connecting these key points with a smooth curve and extending the curve in both directions over the interval  $[-\pi, 4\pi]$ , you obtain the graph shown in below.

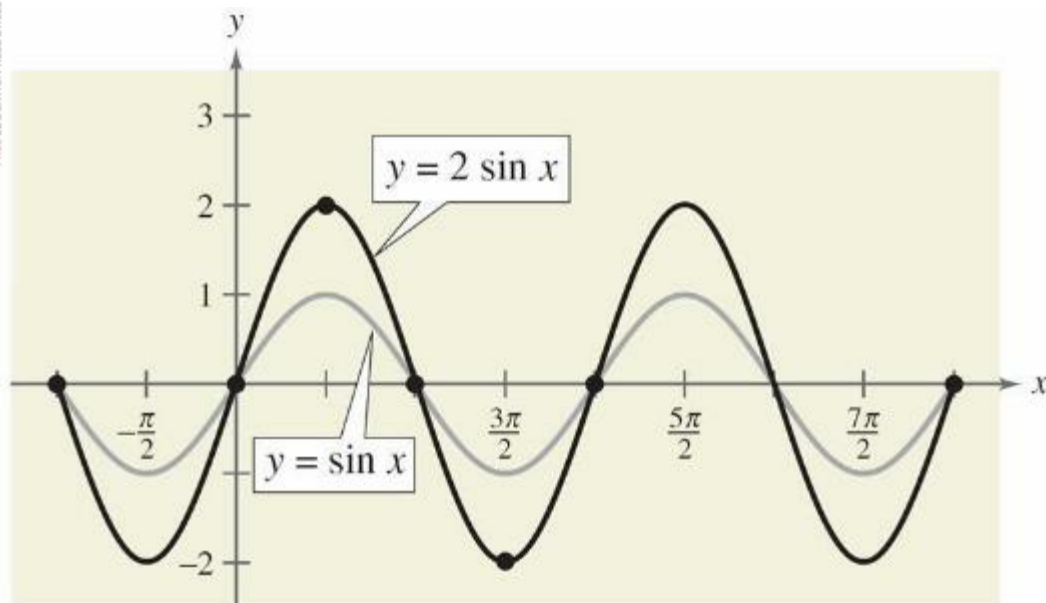

**Example**

Sketch the graph of  $y = \cos x$  for  $0^\circ \leq x \leq 360^\circ$  using an interval of  $30^\circ$

**Solution:**

The values of  $x$  and the corresponding values of  $y$  are given in the table below

$x$	$0^\circ$	$30^\circ$	$60^\circ$	$90^\circ$	$120^\circ$	$150^\circ$	$180^\circ$	$210^\circ$	$240^\circ$
$Y = \cos x$	1	0.8660	0.5	0	-0.5	-0.8660	-1	-0.8660	-0.5

$x$	$270^\circ$	$300^\circ$	$330^\circ$	$360^\circ$
$Y = \cos x$	0	0.5	0.8660	1

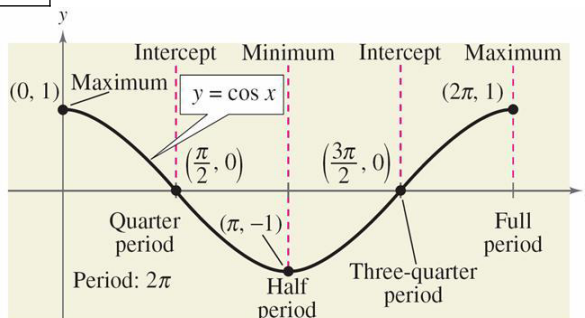
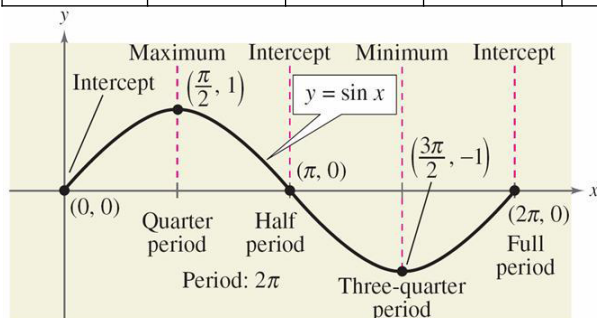

## Definition of Amplitude of Sine and Cosine Curves

The **amplitude** of  $y = a \sin x$  and  $y = a \cos x$  represents half the distance between the maximum and minimum values of the function and is given by

$$\text{Amplitude} = |a|.$$

### Graph of tangents

**Note;**

- As the value of  $x$  approaches  $90^\circ$  and  $270^\circ$   $\tan x$  becomes very large
- Hence the graph of  $y = \tan x$  approaches the lines  $x = 90^\circ$  and  $270^\circ$  without touching them.
- Such lines are called asymptotes

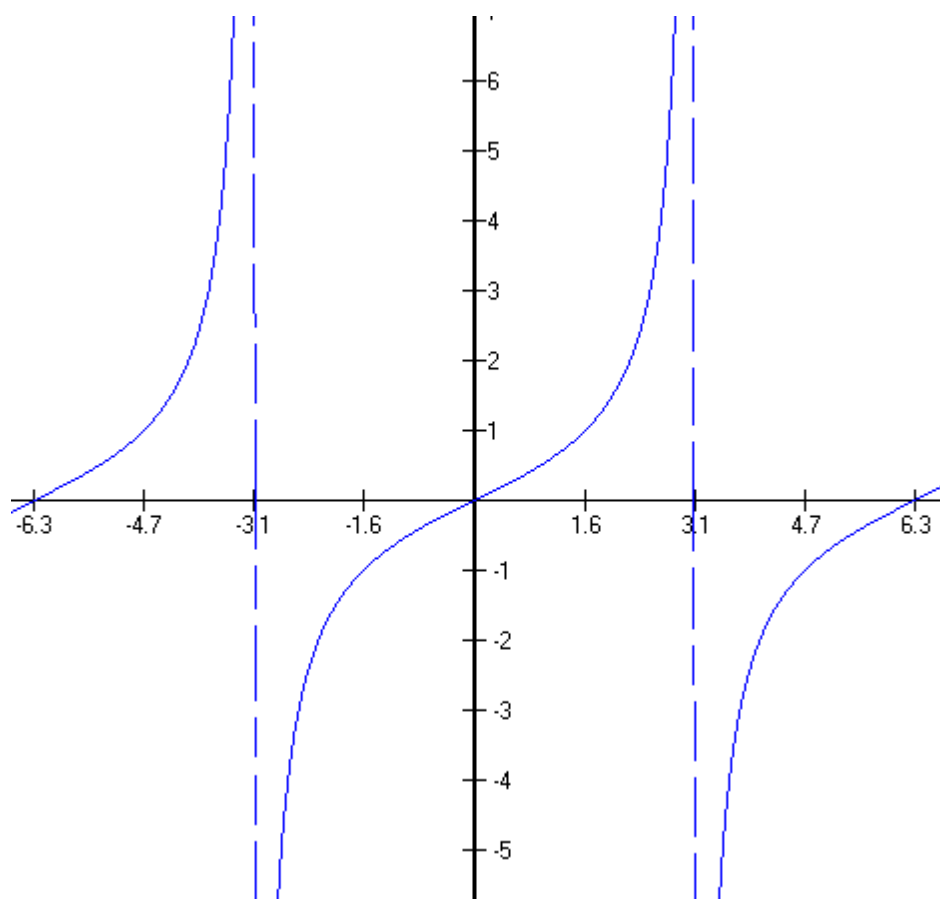

Solution of triangles

**Sin rule**

If a circle of radius  $R$  is circumscribed around the triangle  $ABC$ , then  $\frac{a}{\sin A} = \frac{b}{\sin B} = \frac{c}{\sin C} = 2R$ .

The sine rule applies to both acute and obtuse –angled triangle.

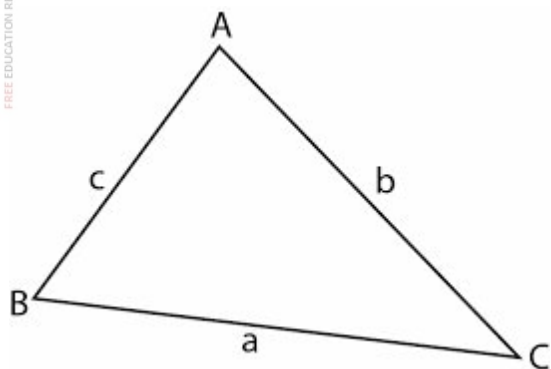

### Example

Solve triangle ABC, given that  $\angle CAB = 42.9^\circ$ ,  $c = 14.6$  cm and  $a = 11.4$  cm

### Solution

To solve a triangle means to find the sides and angles not given

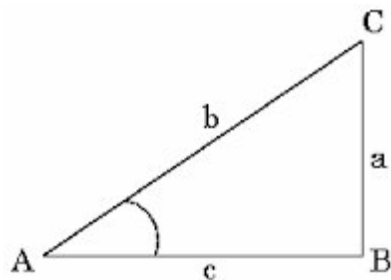

$$\frac{a}{\sin A} = \frac{c}{\sin C}$$

$$\frac{11.4}{\sin 42.9} = \frac{14.6}{\sin C}$$

$$\sin c = \frac{14.6 \sin 42.9}{11.4} = 0.8720$$

Therefore  $c = 60.69^\circ$

Note;

The sin rule is used when we know

- Two sides and a non-included angle of a triangle
- All sides and at least one angle

- All angles and at least one side.

## Cosine rule

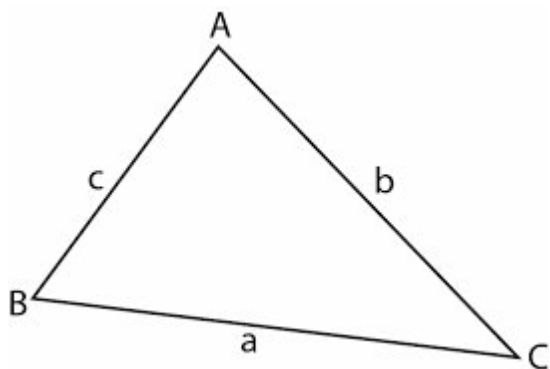

$$a^2 = b^2 + c^2 - 2bc \cos A \text{ OR } b^2 = a^2 + c^2 - 2ac \cos B$$

### Example

Find AC in the figure below, if AB= 4 cm , BC = 6 cm and  $\angle B = 78^\circ$

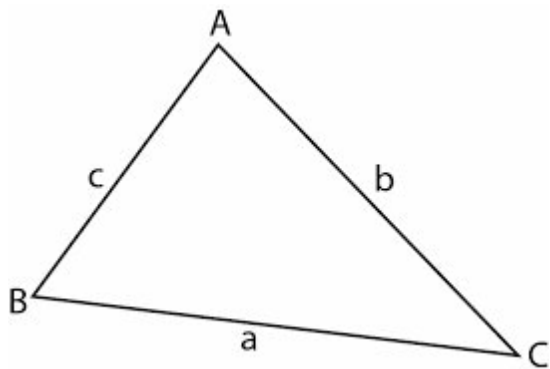

### Solution

Using the cosine rule

$$b^2 + c^2 - 2ac \cos B$$

$$b^2 = a^2 + c^2 - 2ac \cos B$$

$$b^2 = 4^2 + 6^2 - 2 \times 4 \times 6 \cos 78^\circ$$

$$= 16 + 36 - 48 \cos 78^\circ$$

$$= 52 - 9.979$$

$$= 42.02 \text{ cm}$$

**Note;**

The cosine rule is used when we know

- Two sides and an included angle
- All three sides of a triangle

End of topic

Did you understand everything?

If not ask a teacher, friends or anybody and make sure you understand before going to sleep!

## Past KCSE Questions on the topic.

1. Solve the equation

$$\sin \frac{5}{2} \theta = \frac{-1}{2} \text{ for } 0^\circ \leq \theta \leq 180^\circ$$

2. Given that  $\sin \theta = \frac{2}{3}$  and is an acute angle find:

- (a)  $\tan \theta$  giving your answer in surd form  
(b)  $\sec^2 \theta$

3. Solve the 1

equation  $2 \sin^2(x-30^\circ) = \cos 60^\circ$  for  $-180^\circ \leq x \leq 180^\circ$

4. Given that  $\sin(x+30^\circ) = \cos 2x^\circ$  for  $0^\circ, 0^\circ \leq x \leq 90^\circ$  find the value of x. Hence find the value of  $\cos^2 3x^\circ$ .

5. Given that  $\sin a = \frac{1}{\sqrt{5}}$  where a is an acute angle find, without using

$$\sqrt{5}$$

Mathematical tables

(a)  $\cos a$  in the form of  $a/b$ , where  $a$  and  $b$  are rational numbers

(b)  $\tan(90^\circ - a)$ .

6. Give that  $x^\circ$  is an angle in the first quadrant such that  $8 \sin^2 x + 2 \cos x - 5 = 0$

Find:

a)  $\cos x$

b)  $\tan x$

7. Given that  $\cos 2x^\circ = 0.8070$ , find  $x$  when  $0^\circ \leq x \leq 360^\circ$

8. The figure below shows a quadrilateral ABCD in which  $AB = 8 \text{ cm}$ ,  $DC = 12 \text{ cm}$ ,  $\angle BAD = 45^\circ$ ,  $\angle CBD = 90^\circ$  and  $\angle BCD = 30^\circ$ .

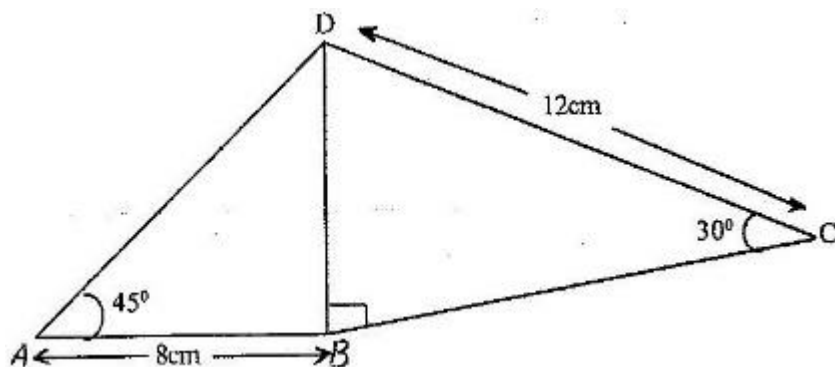

Find:

(a) The length of BD

(b) The size of the angle ADB

9. The diagram below represents a school gate with double shutters. The shutters are such opened through an angle of  $63^\circ$ .

The edges of the gate, PQ and RS are each 1.8 m



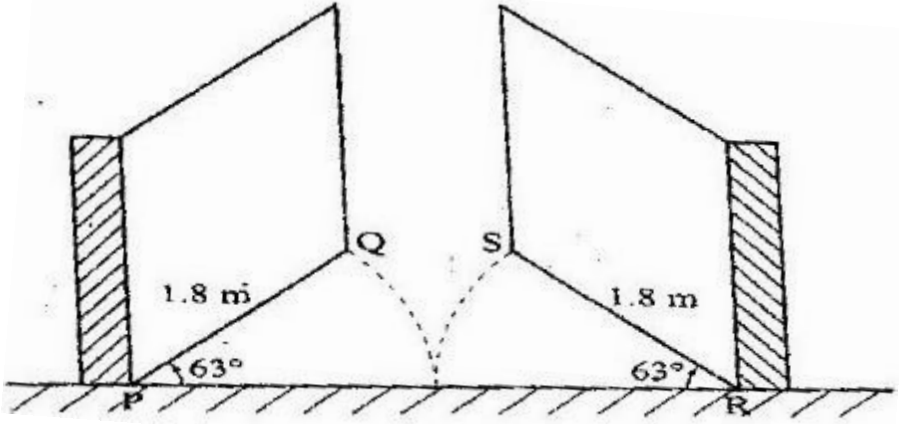

Calculate the shortest distance QS, correct to 4 significant figures

10...The figure below represents a quadrilateral piece of land ABCD divided into three triangular plots. The lengths BE and CD are 100m and 80m respectively. Angle ABE =  $30^\circ$ ,  $\angle ACE = 45^\circ$  and  $\angle ACD = 100^\circ$

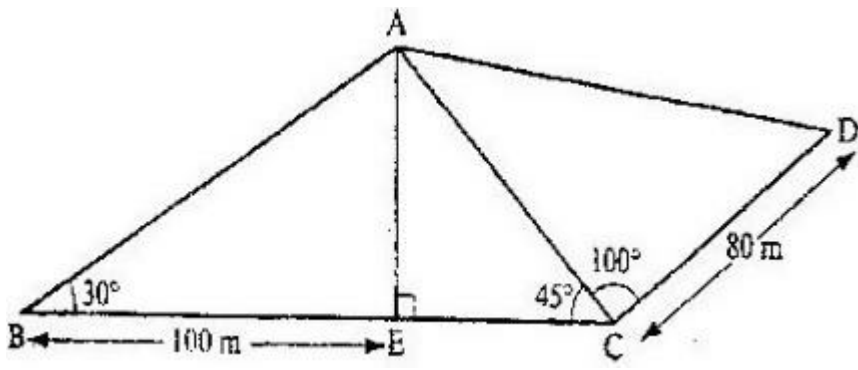

- (a) Find to four significant figures:
- (i) The length of AE
  - (ii) The length of AD
  - (iii) The perimeter of the piece of land

(b) The plots are to be fenced with five strands of barbed wire leaving an entrance of 2.8 m wide to each plot. The type of barbed wire to be used is sold in rolls of lengths 480m. Calculate the number of rolls of barbed wire that must be bought to complete the fencing of the plots.

11. Given that  $x$  is an acute angle and  $\cos x = \frac{2\sqrt{5}}{5}$ , find without using mathematical tables or a calculator,  $\tan (90 - x)^\circ$ .

12. In the figure below  $\angle A = 62^\circ$ ,  $\angle B = 41^\circ$ ,  $BC = 8.4$  cm and CN is the bisector of  $\angle ACB$ .

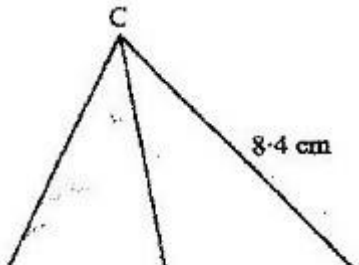

Calculate the length of CN to 1 decimal place.

13. In the diagram below PA represents an electricity post of height 9.6 m. BB and RC represents two storey buildings of heights 15.4 m and 33.4 m respectively. The angle of depression of A from B is  $5.5^\circ$  While the angle of elevation of C from B is  $30.5^\circ$  and  $BC = 35\text{m}$ .

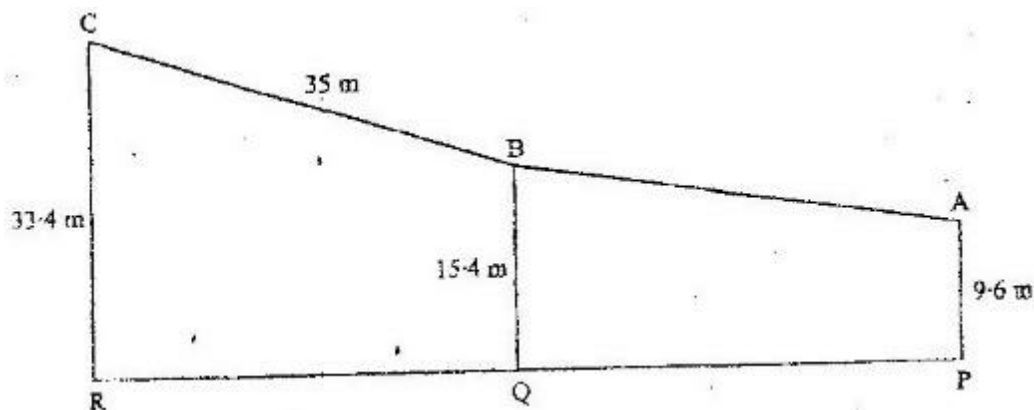

- Calculate, to the nearest metre, the distance AB
- By scale drawing find,
  - The distance AC in metres
  - $\angle BCA$  and hence determine the angle of depression of A from C

More questions

1. Solve the equation: (2 mks)

$$\sin \frac{5}{2} x = -\frac{1}{2} \text{ for } 0^\circ \leq x \leq 180^\circ$$

2. (a) Complete the table below, leaving all your values correct to 2 d.p. for the functions  $y = \cos x$  and  $y = 2\cos(x + 30)^\circ$  (2 mks)

$X^\circ$	$0^\circ$	$60^\circ$	$120^\circ$	$180^\circ$	$240^\circ$	$300^\circ$	$360^\circ$	$420^\circ$	$480^\circ$	$540^\circ$
$\cos X$	1.00			-1.00		0.50				
$2\cos(x+30)$	1.73		-1.73		0.00					

(b) For the function  $y = 2\cos(x+30)^\circ$

State:

- (i) The period (1 mk)  
 (ii) Phase angle (1 mk)

(c) On the same axes draw the waves of the functions  $y = \cos x$  and  $y = 2\cos(x+30)^\circ$  for  $0^\circ \leq x \leq 540^\circ$ . Use the scale 1cm rep  $30^\circ$  horizontally and 2 cm rep 1 unit vertically (4 mks)

(d) Use your graph above to solve the inequality  $2 \cos(x + 30^\circ) \leq \cos x$  (2 mks)

3. Find the value of x in the equation.

$$\cos(3x - 180^\circ) = \frac{\sqrt{3}}{2} \quad \text{in the range } 0^\circ \leq x \leq 180^\circ \quad (3 \text{ marks})$$

4. Given that  $\tan \theta = \frac{11}{60}$  and  $\theta$  is an acute angle, find without using tables  $\cos(90^\circ - \theta)$  (2mks)

5. Solve for  $\theta$  if  $-\frac{1}{4} \sin(2\theta + 30) = 0.1607$ ,  $0 \leq \theta \leq 360^\circ$  (3mks)

6. Given that  $\cos \theta = \frac{5}{13}$  and that  $270^\circ \leq \theta \leq 360^\circ$ , work out the value of  $\tan \theta + \sin \theta$  without using a calculator or mathematical tables. (3 marks)

7. Solve for x in the range  $0^\circ \leq x \leq 180^\circ$  (4mks)  
 $-8 \sin^2 x - 2 \cos x = -5.$

8. If  $\tan x^\circ = \frac{12}{5}$  and x is a reflex angle, find the value of  $5\sin x + \cos x$  without using a calculator or mathematical tables

9. Find  $\theta$  given that  $2 \cos 3\theta - 1 = 0$  for  $0^\circ \leq \theta \leq 360^\circ$

10. Without a mathematical table or a calculator, simplify:  $\cos 300^\circ \times \sin 120^\circ$  giving your answer in  $\cos 330^\circ - \sin 405^\circ$  rationalized surd form.

11. Express in surds form and rationalize the denominator.

$$\frac{1}{\sin 60^\circ \sin 45^\circ - \sin 45^\circ}$$

12. Simplify the following without using tables;

$$\tan 45^\circ + \cos 45^\circ \sin 60^\circ$$

## CHAPTER FOURTY FOUR

### SURDS

#### Specific Objectives

By the end of the topic the learner should be able to:

- (a) Define rational and irrational numbers,
- (b) Simplify expressions with surds;
- (c) Rationalize denominators with surds.

#### Content

- (a) Rational and irrational numbers
- (b) Simplification of surds
- (c) Rationalization of denominators.

## Rational and irrational numbers

### Rational numbers

A **rational** number is a number which can be written in the form  $\frac{p}{q}$ , where p and q are integers and  $q \neq 0$ . The integer's p and q must not have common factors other than 1.

Numbers such as  $2, \frac{1}{2}, \frac{3}{4}\sqrt{4}$  are examples of rational numbers. Recurring numbers are also rational numbers.

### Irrational numbers

Numbers that cannot be written in the form  $\frac{p}{q}$ . Numbers such as  $\pi, \sqrt{2}, \sqrt{3}$  are irrational numbers.

### Surds

Numbers which have got no exact square roots or cube root are called surds e.g.  $\sqrt{2}, \sqrt[3]{8}, \sqrt{28}, \sqrt[3]{16}$  or  $\sqrt[3]{36}$

The product of a surd and a rational number is called a mixed surd. Examples are ;

$$2\sqrt{3}, 4\sqrt{7} \text{ and } \frac{1}{3}\sqrt{2}$$

### Order of surds

$\sqrt{3}, \sqrt{6}$  are surds of order two

$\sqrt[3]{2}, \sqrt[3]{6}$  are surds of order three

$\sqrt[4]{2}, \sqrt[4]{64}$  are surds of order four

### Simplification of surds

A surd can be reduced to its lowest term possible, as follows ;

#### Example

Simplify

a)  $\sqrt{18}$

b)  $\sqrt{72}$

#### Solution

$$\sqrt{18} = \sqrt{9 \times 2}$$

$$\sqrt{9} \times \sqrt{2} = 3\sqrt{2}$$

$$\sqrt{48} = \sqrt{16 \times 3}$$

$$\sqrt{16} \times \sqrt{3} = 4\sqrt{3}$$

### Operation of surds

Surds can be added or subtracted only if they are like surds (that is, if they have the same value under the root sign).

#### Example 1

Simplify the following.

- i.  $3\sqrt{2} + 5\sqrt{2}$
- ii.  $8\sqrt{5} - 2\sqrt{5}$

**Solution**

- i.  $3\sqrt{2} + 5\sqrt{2} = 8\sqrt{2}$
- ii.  $8\sqrt{5} - 2\sqrt{5} = 6\sqrt{5}$

**Summary**

$\sqrt{2} + \sqrt{2}$  Let  $a = \sqrt{2}$

Therefore  $\sqrt{2} + \sqrt{2} = a + a$   
 $= 2a$

But  $a = \sqrt{2}$

Hence  $\sqrt{2} + \sqrt{2} = 2\sqrt{2}$

**Multiplication and Division of surds**

Surds of the same order can be multiplied or divided irrespective of the number under the root sign.

**Law 1:**  $\sqrt{a} \times \sqrt{b} = \sqrt{ab}$  When multiplying surds together, multiply their values together.

e.g.1  $\sqrt{3} \times \sqrt{12} = \sqrt{(3 \times 12)} = \sqrt{36} = 6$

e.g.2  $\sqrt{7} \times \sqrt{5} = \sqrt{35}$

This law can be used in reverse to simplify expressions...

e.g.3  $\sqrt{12} = \sqrt{2} \times \sqrt{6}$  or  $\sqrt{4} \times \sqrt{3} = 2\sqrt{3}$

**Law 2:**  $\sqrt{a} \div \sqrt{b}$  or  $\frac{\sqrt{a}}{\sqrt{b}} = \sqrt{(a/b)}$  When dividing surds, divide their values (and vice versa).

e.g.1  $\frac{\sqrt{12}}{\sqrt{3}} = \sqrt{(12 \div 3)} = \sqrt{4} = 2$

e.g.2  $\frac{\sqrt{6}}{\sqrt{8}} = \frac{\sqrt{3}}{\sqrt{4}}$

**Law 3:**  $\sqrt{(a^2)}$  or  $(\sqrt{a})^2 = a$  When squaring a square-root, (or vice versa), the symbols cancel

Each other out, leaving just the base.

e.g.1  $\sqrt{12^2} = 12$

e.g.2  $\sqrt{7} \times \sqrt{7} = \sqrt{7^2} = 7$

**Note:**

If you add the same surds together you just have that number of surds. E.g.

$$\sqrt{2} + \sqrt{2} + \sqrt{2} = 3\sqrt{2}$$

If a surd has a square number as a factor you can use law 1 and/or law 2 and work backwards to take that out and simplify the surd. E.g.  $\sqrt{500} = \sqrt{100} \times \sqrt{5} = 10\sqrt{5}$

**Rationalization of surds**

Surds may also appear in fractions. Rationalizing the denominator of such a fraction means finding an equivalent fraction that does NOT have a surd on the bottom of the fraction (though it CAN have a surd on the top!).

If the surd contains a square root by itself or a multiple of a square root, to get rid of it, you must multiply BOTH the top and bottom of the fraction by that square root value.

e.g.  $\frac{6}{\sqrt{7}} \times \frac{\sqrt{7}}{\sqrt{7}} = \frac{6\sqrt{7}}{7}$

e.g.2  $\frac{6 + \sqrt{2}}{2\sqrt{3}} \times \frac{\sqrt{3}}{\sqrt{3}} = \frac{6\sqrt{3} + \sqrt{2} \times \sqrt{3}}{2 \times \sqrt{3} \times \sqrt{3}} = \frac{6\sqrt{3} + \sqrt{6}}{6}$   
 i.e.  $2 \times 3$

If the surd on the bottom involves addition or subtraction with a square root, to get rid of the square root part you must use the 'difference of two squares' and multiply BOTH the top and bottom of the fraction by the bottom surd's expression but with the inverse operation.

e.g.3  $\frac{7}{2 + \sqrt{2}} \times \frac{(2 - \sqrt{2})}{(2 - \sqrt{2})} = \frac{14 - 7\sqrt{2}}{2^2 - (\sqrt{2})^2} = \frac{14 - 7\sqrt{2}}{4 - 2}$   
 i.e.  $4 - 2$

**Notes on the 'Difference of two squares'...**

Squaring...  $(2 + \sqrt{2})(2 + \sqrt{2}) = 2(2 + \sqrt{2}) + \sqrt{2}(2 + \sqrt{2})$   
 (ops the same)  
 $= 4 + 2\sqrt{2} + 2\sqrt{2} + \sqrt{2}\sqrt{2}$   
 $= 4 + 4\sqrt{2} + 2 = 6 + \sqrt{2}$  (still a surd)

Multiplying...  $(2 + \sqrt{2})(2 - \sqrt{2}) = 2(2 - \sqrt{2}) + \sqrt{2}(2 - \sqrt{2})$   
 (opposite ops)  
 $= 4 - 2\sqrt{2} + 2\sqrt{2} - \sqrt{2}\sqrt{2}$   
 $= 4 - 2 = 2$  (not a surd)

In essence, as long as the operation in each brackets is the opposite, the middle terms will always cancel each other out and you will be left with the first term squared subtracting the second term squared.

i.e.  $(5 + \sqrt{7})(5 - \sqrt{7}) \rightarrow 5^2 - (\sqrt{7})^2 = 25 - 7 = 18$

**Example**

Simplify by rationalizing the denominator

$$\frac{\sqrt{2} + \sqrt{3}}{\sqrt{6} - \sqrt{3}}$$

**Solution**

isabokemicah@gmail.com

$$\begin{aligned} \frac{\sqrt{2}+\sqrt{3}}{\sqrt{6}-\sqrt{3}} &= \frac{\sqrt{2}+\sqrt{3}}{\sqrt{6}-\sqrt{3}} \times \frac{\sqrt{6}+\sqrt{3}}{\sqrt{6}+\sqrt{3}} \\ &= \frac{\sqrt{2}(\sqrt{6}+\sqrt{3})+\sqrt{3}(\sqrt{6}+\sqrt{3})}{\sqrt{6}(\sqrt{6}+\sqrt{3})-\sqrt{3}(\sqrt{6}+\sqrt{3})} \\ &= \frac{\sqrt{12}+\sqrt{6}+\sqrt{18}+\sqrt{9}}{\sqrt{36}+\sqrt{18}-\sqrt{18}-\sqrt{9}} \\ &= \frac{\sqrt{4} \times \sqrt{3}+\sqrt{6}+\sqrt{9} \times \sqrt{2}+\sqrt{3}}{6-3} \\ &= \frac{2\sqrt{3}+\sqrt{6}+3\sqrt{2}+3}{3} \end{aligned}$$

### Note

If the product of the two surds gives a rational number then the product of the two surds gives conjugate surds.

End of topic

Did you understand everything?

If not ask a teacher, friends or anybody and make sure you understand before going to sleep!

## Past KCSE Questions on the topic.

- Without using logarithm tables, find the value of x in the equation

$$\text{Log } x^3 + \log 5x = 5 \log 2 - \log 2$$

- Simplify  $(1 \div \sqrt{3})(1 - \sqrt{3})$

Hence evaluate  $\frac{1}{1 + \sqrt{3}}$  to 3 s.f. given that  $\sqrt{3} = 1.7321$

- If  $\frac{\sqrt{14}}{\sqrt{7}-\sqrt{2}} - \frac{\sqrt{14}}{\sqrt{7}+\sqrt{2}} = a\sqrt{7} + b\sqrt{2}$

Find the values of a and b where a and b are rational numbers.

- Find the value of x in the following equation  $49^{(x+1)} + 7^{(2x)} = 350$
- Find x if  $3 \log 5 + \log x^2 = \log 1/125$



6. Simplify as far as possible leaving your answer in form of a surd

$$\frac{1}{\sqrt{14} - 2\sqrt{3}} - \frac{1}{\sqrt{14} + 2\sqrt{3}}$$

7. Given that  $\tan 75^\circ = 2 + \sqrt{3}$ , find without using tables  $\tan 15^\circ$  in the form  $p+q\sqrt{m}$ , where p, q and m are integers.

8. Without using mathematical tables, simplify

$$\frac{63\sqrt{\quad} + 72\sqrt{\quad}}{\sqrt{32} + \sqrt{28}}$$

9. Simplify  $\frac{3}{\sqrt{5}-2} + \frac{1}{\sqrt{5}}$  leaving the answer in the form  $a + b\sqrt{c}$ , where a, b and c are rational numbers

For free KCSE Notes, Exams, and Past Papers Visit <https://Teacher.co.ke/>

CHAPTER FOURTY FIVE

**FURTHER LOGARITHMS**

## Specific Objectives

By the end of the topic the learner should be able to:

- (a) Derive logarithmic relation from index form and vice versa;
- (b) State the laws of logarithms;
- (c) Use logarithmic laws to simplify logarithmic expressions and solve logarithmic equations;
- (d) Apply laws of logarithms for further computations.

## Content

- (a) Logarithmic notation (eg.  $a^n = b$ ,  $\log_a b = n$ )
- (b) The laws of logarithms:  $\log(AB) = \log A + \log B$ ,  $\log(A^B) = B \log A$  and  $\log \frac{A}{B} = \log A - \log B$  and  $\log A^n = n \times \log A$ .
- (c) Simplifications of logarithmic expressions
- (d) Solution of logarithmic equations
- (e) Further computation using logarithmic laws.

If  $y = a^x$  then we introduce the inverse function logarithm and **define**  $\log_a y = x$

(Read as log base  $a$  of  $y$  equals  $x$ ).

In general

$$y = a^x \Leftrightarrow \log_a y = x$$

Where  $\Leftrightarrow$  means “implies and is implied by” i.e. it works both ways!

Note this means that, going from exponent form to logarithmic form:

$10^2 = 100 \Rightarrow \log_{10}(100) = 2$	$10^{-2} = 0.01 \Rightarrow \log_{10}(0.01) = -2$
$10^0 = 1 \Rightarrow \log_{10}(1) = 0$	$2^5 = 32 \Rightarrow \log_2(32) = 5$
$9^{\frac{1}{2}} = 3 \Rightarrow \log_9(3) = \frac{1}{2}$	$8^{\frac{2}{3}} = 4 \Rightarrow \log_8(4) = \frac{2}{3}$

And in going from logarithmic form to exponent form:

$\log_{10}(10) = 1 \Rightarrow 10^1 = 10$	$\log_{10}(0.001) = -3 \Rightarrow 10^{-3} = 0.001$
$\log_2(1) = 0 \Rightarrow 2^0 = 1$	$\log_3(81) = 4 \Rightarrow 3^4 = 81$
$\log_{100}(10) = \frac{1}{2} \Rightarrow 100^{\frac{1}{2}} = 10$	$\log_5(5\sqrt{5}) = \frac{3}{2} \Rightarrow 5^{\frac{3}{2}} = 5\sqrt{5}$

## Laws of logarithms

### Product and Quotient Laws of Logarithms:

$$\log_a(M \times N) = \log_a M + \log_a N \quad \text{The Product Law}$$

$$\log_a\left(\frac{M}{N}\right) = \log_a M - \log_a N \quad \text{The Quotient Law}$$

### Example.

$$\begin{aligned} \log_6 9 + \log_6 8 - \log_6 2 \\ &= \log_6(72) - \log_6 2 \\ &= \log_6\left(\frac{72}{2}\right) = \log_6(36) \\ &= 2 \end{aligned}$$

### The Power Law of Logarithms:

$$\log_a M^n = n \log_a M$$

**Example.**

$$\begin{aligned}
 &2\log 5 + 2\log 2 \\
 &= \log 5^2 + \log 2^2 \\
 &= \log 25 + \log 4 \\
 &= \log 100 = \log_{10} 100 \\
 &= 2
 \end{aligned}$$

### Logarithm of a Root

$$\log_b x^{\frac{1}{n}} = \frac{1}{n} \log_b x \quad \text{or} \quad \log_b \sqrt[n]{x} = \frac{\log_b x}{n}$$

**Example.**

$$\log_3 \sqrt[5]{27} \rightarrow \log_3 27^{\frac{1}{5}} \rightarrow \frac{1}{5} \log_3 27 \rightarrow \frac{1}{5} (3) = \frac{3}{5}$$

### PROOF OF PROPERTIES

Property	Proof	Reason for Step
1. $\log_b b = 1$ and $\log_b 1 = 0$	$b^1 = b$ and $b^0 = 1$	Definition of logarithms
2. (product rule) $\log_b xy = \log_b x + \log_b y$	a. Let $\log_b x = m$ and $\log_b y = n$ b. $x = b^m$ and $y = b^n$ c. $xy = b^m \cdot b^n$ d. $xy = b^{m+n}$ e. $\log_b xy = m + n$ f. $\log_b xy = \log_b x + \log_b y$	a. Setup b. Rewrite in exponent form c. Multiply together d. Product rule for exponents e. Rewrite in log form f. Substitution
3. (quotient rule) $\log_b \frac{x}{y} = \log_b x - \log_b y$	a. Let $\log_b x = m$ and $\log_b y = n$ b. $x = b^m$ and $y = b^n$	a. Given: compact form b. Rewrite in exponent form

	<p>c. <math>\frac{x}{y} = \frac{b^m}{b^n}</math></p> <p>d. <math>\frac{x}{y} = b^{m-n}</math></p> <p>e. <math>\log_b \frac{x}{y} = m - n</math></p> <p>f. <math>\log_b \frac{x}{y} = \log_b x - \log_b y</math></p>	<p>c. Divide</p> <p>d. Quotient rule for exponents</p> <p>e. Rewrite in log form</p> <p>f. Substitution</p>
<p>4. (power rule) <math>\log_b x^n = n \log_b x</math></p>	<p>a. Let <math>m = \log_b x</math> so <math>x = b^m</math></p> <p>b. <math>x^n = b^{mn}</math></p> <p>c. <math>\log_b x^n = mn</math></p> <p>d. <math>\log_b x^n = n \log_b x</math></p>	<p>a. Setup</p> <p>b. Raise both sides to the nth power</p> <p>c. Rewrite as log</p> <p>d. Substitute</p>
<p>5. Properties used to solve log equations:</p> <p>a. if <math>b^x = b^y</math>, then <math>x = y</math></p> <p>b. if <math>\log_b x = \log_b y</math>, then <math>x = y</math></p>	<p>a. This follows directly from the properties for exponents.</p> <p>b. i. <math>\log_b x - \log_b y = 0</math></p> <p>ii. <math>\log_b \frac{x}{y} = 0</math></p> <p>iii. <math>\frac{x}{y} = b^0</math></p> <p>iv. <math>\frac{x}{y} = 1</math> so <math>x = y</math></p>	<p>b. i. Subtract from both sides</p> <p>ii. Quotient rule</p> <p>iii. Rewrite in exponent form</p> <p>iv. <math>b^0 = 1</math></p>

## Solving exponential and logarithmic equations

By taking logarithms, an exponential equation can be converted to a linear equation and solved. We will use the process of taking logarithms of both sides.

### Example.

a)  $4^x = 12$

$$\log 4^x = \log 12$$

$$x \log 4 = \log 12$$

$$x = \frac{\log 12}{\log 4} \quad x = 1.792$$

### Note;

A logarithmic expression is defined only for positive values of the argument. When we solve a logarithmic equation it is essential to verify that the solution(s) does not result in the logarithm of a negative number. Solutions that would result in the logarithm of a negative number are called **extraneous**, and are not valid solutions.

### Example.

Solve for x:

$$\log_5 (x+1) + \log_5 (x-3) = 1 \rightarrow (\text{the one becomes an exponent : } 5^1)$$

$$\log_5 (x+1)(x-3) = 5$$

$$x^2 - 2x - 3 - 5 = 0$$

$$x^2 - 2x - 8 = 0$$

$$(x-4)(x+2) = 0 \rightarrow x = 4, x = -2 (\text{extraneous})$$

Verify:

$$\log_5 (4+1) + \log_5 (4-3) = 1$$

$$\log_5 5 + \log_5 1 = 1$$

$$1+0 = 1$$

$$\log_5 (-2+1) + \log_5 (-2-3) = 1$$

$$\log_5 (-1) + \log_5 (-5) \quad \text{not possible}$$

## Solving equations using logs

### Examples

(i) Solve the equation  $10^x = 3.79$

The definition of logs says if  $y = a^x$  then  $\log_a y = x$  or  $y = a^x \Leftrightarrow x = \log_a y$

Hence  $10^x = 3.79 \Rightarrow x = \log_{10} 3.79 = 0.57864$  (to 5 decimal places)

Check  $10^{0.57864} = 3.79000$  (to 5 decimal places)

In practice from  $10^x = 3.79$  we take logs to base 10 giving

$$\log_{10} (10^x) = \log (3.79)$$

$$x \log_{10} (10) = \log (3.79)$$

$$x = 0.57864$$

(ii) Solve the equation  $3^{2x} = 56$

$$\log_{10} (3^{2x}) = \log_{10} (56)$$

$$2x \log_{10} (3) = \log_{10} (56)$$

$$2x = \frac{\log_{10} (56)}{\log_{10} (3)} = 3.66403 \dots$$

$$x = 1.83201 \dots$$

Check  $3^3 = 27$ ,  $3^4 = 81$ , we want  $3^{2x}$  so the value of  $2x$  lies between 3 and 4 or  $3 < 2x < 4$  which means  $x$  lies between 1.5 and 2. This tells us that  $x = 1.83201 \dots$  is roughly correct.

(iii) Solve the equation  $4^x = 3^{x+1}$

$$4^x = 3^{x+1}$$

$$x \log_{10} 4 = (x+1) \log_{10} 3$$

$$= x \log_{10} 3 + \log_{10} 3$$

$$x \log_{10} 4 - x \log_{10} 3 = \log_{10} 3$$

$$x(\log_{10} 4 - \log_{10} 3) = \log_{10} 3$$

$$x = \frac{\log_{10} 3}{\log_{10} 4 - \log_{10} 3} = 3.8188 \dots$$

Check  $\left\{ \begin{array}{l} 4^x = 4^{3.8188 \dots} \cong 4^4 = 256 \\ 3^{x+1} = 3^{4.8188 \dots} \cong 3^5 = 243 \end{array} \right\}$  very close!

Note you could combine terms, giving,

$$x = \frac{\log_{10} 3}{\log_{10} 4 - \log_{10} 3} = \frac{\log_{10} 3}{\log_{10} \left(\frac{4}{3}\right)} = 3.8188 \dots$$

(iv) Solve the equation  $4^{x+6} = 3^{5-2x}$

$$4^{x+6} = 3^{5-2x}$$

$$(x + 6) \log 4 = (5 - 2x) \log 3$$

Take logs of both sides

$$x \log 4 + 6 \log 4 = 5 \log 3 - 2x \log 3$$

Expand brackets

$$x \log 4 + 2x \log 3 = 5 \log 3 - 6 \log 4$$

Collect terms

$$x(\log 4 + 2 \log 3) = 5 \log 3 - 6 \log 4$$

Factorise the left hand side

$$x = \frac{5 \log 3 - 6 \log 4}{\log 4 + 2 \log 3} = -0.78825$$

divide

(Note you get the same answer by using the ln button on your calculator.)

$$\text{Check } 4^{x+6} = 4^{-0.78825 + 6} = 4^{5.21175} = 1373.368 \text{ and } 3^{5-2x} = 3^{5-2(-.78825)} = 3^{6.576498} = 1373.368$$

Notice that you could combine the log-terms in

$$x = \frac{5 \log 3 - 6 \log 4}{\log 4 + 2 \log 3} \text{ to give } x = \frac{\log (3^5 \div 4^6)}{\log (4 \times 3^2)}$$

It does not really simplify things here but, in some cases, it can.

(v) Solve the equation  $7(3^{x-1}) = 2(5^{2x+1})$



isabokemicah@gmail.com

$$7(3^{x-1}) = 2(5^{2x+1})$$

$$\log 7 + (x-1)\log 3 = \log 2 + (2x+1)\log 5$$

Take logs of both sides

$$\log 7 + x\log 3 - \log 3 = \log 2 + 2x\log 5 + \log 5$$

Expand brackets

$$x\log 3 - 2x\log 5 = \log 2 + \log 5 - \log 7 + \log 3$$

Collect terms

$$x(\log 3 - 2\log 5) = \log \left(\frac{2 \times 5 \times 3}{7}\right)$$

$$x \log \left(\frac{3}{25}\right) = \log \left(\frac{30}{7}\right)$$

Factorize left hand side

$$x = \frac{\log \left(\frac{30}{7}\right)}{\log \left(\frac{3}{25}\right)} = \frac{0.632023}{-0.920819} = -0.686371$$

simplify

divide

Check

$$\text{LHS} = 7(3^{x-1}) \approx 7 \times 3^{-1.7} \approx \frac{7}{3^2} = \frac{7}{9} \quad (\text{taking } 3^{1.7} \approx 3^2 = 9)$$

$$\text{RHS} = 2(5^{2x+1}) = 2 \times 5^{-0.4} = \frac{2}{5^{0.4}} \approx \frac{2}{\sqrt{5}} \approx 1 \quad (\text{taking } 5^{0.4} \approx 5^{0.5} = \sqrt{5} = 2.2\dots)$$

The values of LHS and RHS are roughly the same. A more exact check could be made using a calculator.

## Logarithmic equations and expressions

Consider the following equations

$$\log_3 81 = x \quad \text{and} \quad \log_x 8 = 3$$

The value of x in each case is established as follows

$$\log_3 81 = x$$

isabokemicah@gmail.com

Therefore  $3^x = 81$

$$3^x = 3^4$$

$$x = 4$$

$$\log_x 8 = 3$$

$$x^3 = 8$$

$$x^3 = 2^3$$

$$x = 2$$

### Example

Solve  $\log_6 2$

### Solution

Let  $\log_6 2 = t$ . then  $6^t = 2$

Introducing logarithm to base 10 on both sides

$$\log 6^t = \log 2$$

$$t \log 6 = \log 2$$

$$t = \frac{\log 2}{\log 6}$$

$$t = \frac{0.3010}{0.7782}$$

$$t = 0.3868$$

Therefore  $\log_6 2 = 0.3868$

### Example

$$2^{2x} + 3(2^x) - 4 = 0$$

Taking logs on both sides cannot help in getting the value of  $x$ , since  $2^{2x} + 3(2^x)$  cannot be combined into a single expression. However if we let  $2^x = y$  then the equation becomes quadratic in  $y$ .

### Solution

Thus, let  $2^x = y$ ..... (1)

Therefore  $y^2 + 3y - 4 = 0$ .....(2)

$$(y + 4)(y - 1) = 0$$

isabokemicah@gmail.com

$$y = -4 \text{ or } y = 1$$

Substituting for y in equation (1);

$$\text{Let } 2^x = -4 \text{ or let } 2^x = 1$$

There is no real value of x for which  $2^x = -4$  hence  $2^x = 1$

$$x = 0$$

### Example

$$\text{Solve for x in } (\log_{10} x)^2 = 3 - \log_{10} x^2$$

### Solution

$$\text{Let } \log_{10} x = t \dots \dots \dots (1)$$

$$\text{Therefore } t^2 = 3 - 2t$$

$$t^2 + 2t - 3 = 0 \text{ solve the quadratic equation using any method}$$

$$t^2 + 3t - t - 3 = 0$$

$$t(t + 3) - 1(t - 3) = 0$$

$$(t - 1)(t + 3) = 0$$

$$t = 1 \text{ or } t = -3$$

Substituting for t in the equation (1).

$$\log_{10} x = 1 \text{ or } \log_{10} x = -3$$

$$10^1 = 1 \text{ or } 10^{-3} = x$$

$$x = 10 \text{ or } \frac{1}{1000}$$

Note;

$$\log_b = \frac{1}{\log_a b}$$

End of topic

Did you understand everything?

If not ask a teacher, friends or anybody and make sure you understand before going to sleep!

## Past KCSE Questions on the topic.

1. Solve for  $(\log_3 x)^2 - \frac{1}{2} \log_3 x = 3/2$
2. Find the values of x which satisfy the equation  $5^{2x} - 6(5^x) + 5 = 0$
3. Solve the equation  
 $\text{Log}(x + 24) - 2 \log 3 = \log(9 - 2x)$
4. Find the value of x in the following equation  $49^{(x+1)} + 7^{(2x)} = 350$
5. Find x if  $3 \log 5 + \log x^2 = \log 1/125$
6. Without using logarithm tables, find the value of x in the equation  
$$\text{Log } x^3 + \log 5x = 5 \log 2 - \log \frac{2}{5}$$
7. Given that  $P = 3^y$  express the questions  $3^{2y-1} + 2 \times 3^{(y-1)} = 1$  in terms of P
8. Hence or otherwise find the value of y in the equation:  $3^{(2y-1)} + 2 \times 3^{(y-1)} = 1$

## CHAPTER FOURTY SIX

### COMMERCIAL ARITHMETIC II

#### Specific Objectives

By the end of the topic the learner should be able to:

- (a) Define principal, rate and time in relation to interest;
- (b) Calculate simple interest using simple interest formula;
- (c) Calculate compound interest using step by step method;
- (d) Derive the compound interest formula;
- (e) Apply the compound interest formula for calculating interest;
- (f) Define appreciation and depreciation;
- (g) Use compound interest formula to calculate appreciation and depreciation;
- (h) Calculate hire purchase;
- (i) Calculate income tax given the income tax bands.

#### Content

- (a) Principal rate and time
- (b) Simple interest

- (c) Compound interest using step by step method
- (d) Derivation of compound interest formula
- (e) Calculations using the compound interest formula
- (f) Appreciation and depreciation
- (g) Calculation of appreciation and depreciation using the compound interest formula
- (h) Hire purchase
- (i) Income tax.

## Simple interest

Interest is the money charged for the use of borrowed money for a specific period of time. If money is borrowed or deposited it earns interest, Principle is the sum of money borrowed or deposited P, Rate is the ratio of interest earned in a given period of time to the principle.

The rate is expressed as a percentage of the principal per annum (P.A).When interest is calculated using only the initial principal at a given rate and time, it is called simple interest (I).

### Simple interest formulae

$$\text{Simple interest} = \frac{\text{principle} \times \text{rate} \times \text{time}}{100}$$

### Example

Franny invests ksh 16,000 in a savings account. She earns a simple interest rate of 14%, paid annually on her investment. She intends to hold the investment for  $1 \frac{1}{2}$  years. Determine the future value of the investment at maturity.

### Solution

$$\begin{aligned} I &= \frac{PRT}{100} \\ &= \text{sh. } 16000 \times \frac{14}{100} \times \frac{3}{2} \\ &= \text{sh } 3360 \end{aligned}$$

$$\text{Amount} = P + I$$

$$= \text{sh.}16000 + \text{sh } 3360$$

$$= \text{sh.}19360$$

### Example

Calculate the rate of interest if sh 4500 earns sh 500 after  $1\frac{1}{2}$  years.

**Solution**

From the simple interest formulae

$$I = \frac{PRT}{100}$$

$$R = \frac{100 \times I}{P \times T}$$

P = sh 4500

I = sh 500

T =  $1\frac{1}{2}$  years

Therefore  $R = \frac{100 \times 500}{4500 \times \frac{3}{2}}$

R 7.4 %

**Example**

Esha invested a certain amount of money in a bank which paid 12% p.a. simple interest. After 5 years, his total savings were sh 5600. Determine the amount of money he invested initially.

**Solution**

Let the amount invested be sh P

T = 5 years

R = 12 % p.a.

A = sh 5600

But A = P + I

$$\begin{aligned} \text{Therefore } 5600 &= P + P \times \frac{12}{100} \times 5 \\ &= P + 0.60 P \\ &= 1.6 P \end{aligned}$$

$$\begin{aligned} \text{Therefore } p &= \frac{5600}{1.6} \\ &= \text{sh } 3500 \end{aligned}$$

## Compound interest

Suppose you deposit money into a financial institution, it earns interest in a specified period of time. Instead of the interest being paid to the owner it may be added to (compounded with) the principle and therefore also earns interest. The interest earned is called compound interest. The period after which its compounded to the principle is called interest period.

The compound interest maybe calculated annually, semi-annually, quarterly, monthly etc. If the rate of compound interest is R% p.a and the interest is calculated n times per year, then the rate of interest per period is  $\left(\frac{R}{n}\right)\%$

### Example

Moyo lent ksh.2000 at interest of 5% per annum for 2 years. First we know that simple interest for 1<sup>st</sup> year and 2<sup>nd</sup> year will be same

$$\text{i.e.} = 2000 \times 5 \times 1/100 = \text{Ksh. } 100$$

Total simple interest for 2 years will be = 100 + 100 = ksh. 200

In Compound Interest (C I) the first year Interest will be same as of Simple Interest (SI) i.e. Ksh.100. But year II interest is calculated on P + SI of 1<sup>st</sup> year i.e. on ksh. 2000 + ksh. 100 = ksh. 2100.

So, year II interest in Compound Interest becomes

$$= 2100 \times 5 \times 1/100 = \text{Ksh. } 105$$

So it is Ksh. 5 more than the simple interest. This increase is due to the fact that SI is added to the principal and this ksh. 105 is also added in the principal if we have to find the compound interest after 3 years. Direct formula in case of compound interest is

$$A = P \left(1 + \frac{r}{100}\right)^t$$

Where A = Amount

P = Principal

R = Rate % per annum

T = Time

A = P + CI

$$P \left(1 + \frac{r}{100}\right)^t = P + CI$$

## Types of Question:

Type I: To find CI and Amount

Type II: To find rate, principal or time

Type III: When difference between CI and SI is given.

Type IV: When interest is calculated half yearly or quarterly etc.

Type V: When both rate and principal have to be found.

### Type 1

#### Example

Find the amount of ksh. 1000 in 2 years at 10% per annum compound interest.

#### Solution.

$$\begin{aligned}A &= P (1 + r/100)^t \\&= 1000 (1 + 10/100)^2 \\&= 1000 \times 121/100 \\&= \text{ksh. } 1210\end{aligned}$$

#### Example

Find the amount of ksh. 6250 in 2 years at 4% per annum compound interest.

#### Solution.

$$\begin{aligned}A &= P (1 + r/100)^t \\&= 6250 (1 + 4/100)^2 \\&= 6250 \times 676/625 \\&= \text{ksh. } 6760\end{aligned}$$

#### Example

What will be the compound interest on ksh 31250 at a rate of 4% per annum for 2 years?

#### Solution.

$$\begin{aligned}CI &= P (1 + r/100)^t - P \\&= 31250 \{ (1 + 4/100)^2 - 1 \} \\&= 31250 (676/625 - 1) \\&= 31250 \times 51/625 = \text{ksh. } 2550\end{aligned}$$

#### Example



A sum amounts to ksh. 24200 in 2 years at 10% per annum compound interest.

Find the sum ?

**Solution.**

$$\begin{aligned}
 A &= P (1 + r/100)^t \\
 24200 &= P (1 + 10/100)^2 \\
 &= P (11/10)^2 \\
 &= 24200 \times 100/121 \\
 &= \text{ksh. } 20000
 \end{aligned}$$

## Type II

**Example.**

The time in which ksh. 15625 will amount to ksh. 17576 at 4% compound interest is?

**Solution**

$$\begin{aligned}
 A &= P (1 + r/100)^t \\
 17576 &= 15625 (1 + 4/100)^t \\
 17576/15625 &= (26/25)^t \\
 (26/25)^t &= (26/25)^3 \\
 t &= 3 \text{ years}
 \end{aligned}$$

**Example**

The rate percent if compound interest of ksh. 15625 for 3 years is Ksh. 1951.

**Solution.**

$$\begin{aligned}
 A &= P + CI \\
 &= 15625 + 1951 = \text{ksh. } 17576 \\
 A &= P (1 + r/100)^t \\
 17576 &= 15625 (1 + r/100)^3 \\
 17576/15625 &= (1 + r/100)^3 \\
 (26/25)^3 &= (1 + r/100)^3 \\
 26/25 &= 1 + r/100 \\
 26/25 - 1 &= r/100
 \end{aligned}$$

$$1/25 = r/100$$

$$r = 4\%$$

### Type IV

#### 1. Remember

When interest is compounded half yearly then Amount =  $P \left(1 + \frac{R}{2}\right)^{2t}$

-----  
100

I.e. in half yearly compound interest rate is halved and time is doubled.

2. When interest is compounded quarterly then rate is made  $\frac{1}{4}$  and time is made 4 times.

$$\text{Then } A = P \left[\frac{(1+R/4)}{100}\right]^{4t}$$

3. When rate of interest is  $R_1\%$ ,  $R_2\%$ , and  $R_3\%$  for 1<sup>st</sup>, 2<sup>nd</sup> and 3<sup>rd</sup> year respectively; then  $A = P \left(1 + \frac{R_1}{100}\right) \left(1 + \frac{R_2}{100}\right) \left(1 + \frac{R_3}{100}\right)$

### Example

Find the compound interest on ksh.5000 at 20% per annum for 1.5 year compound half yearly.

### Solution.

When interest is compounded half yearly

$$\text{Then Amount} = P \left[\frac{(1 + R/2)}{100}\right]^{2t}$$

$$\text{Amount} = 5000 \left[\frac{(1 + 20/2)}{100}\right]^{3/2}$$

$$= 5000 \left(1 + \frac{10}{100}\right)^3$$

$$= 5000 \times \frac{1331}{1000}$$

$$= \text{ksh } 6655$$

$$\text{CI} = 6655 - 5000 = \text{ksh. } 1655$$

e.g.

Find compound interest ksh. 47145 at 12% per annum for 6 months, compounded quarterly.

### Solution.

As interest is compounded quarterly

$$A = \left[\frac{P(1 + R/4)}{100}\right]^{4t}$$

$$A = 47145 \left[\frac{(1 + 12/4)}{100}\right]^{\frac{1}{2} \times 4}$$

$$\begin{aligned}
 &= 47145 (1 + 3/100)^2 \\
 &= 47145 \times 103/100 \times 103/100 \\
 &= \text{ksh. } 50016.13 \\
 \text{CI} &= 50016.13 - 47145 \\
 &= \text{ksh. } 2871.13
 \end{aligned}$$

### Example

Find the compound interest on ksh. 18750 for 2 years when the rate of interest for 1<sup>st</sup> year is 45 and for 2<sup>nd</sup> year 8%.

### Solution.

$$\begin{aligned}
 A &= P (1 + R_1/100) (1 + R_2/100) \\
 &= 18750 * 104/100 * 108/100 \\
 &= \text{ksh. } 21060 \\
 \text{CI} &= 21060 - 18750 \\
 &= \text{ksh. } 2310
 \end{aligned}$$

### Type V

#### Example

The compound interest on a certain sum for two years is ksh. 52 and simple interest for the same period at same rate is ksh.50 find the sum and the rate.

### Solution.

We will do this question by basic concept. Simple interest is same every year and there is no difference between SI and CI for 1<sup>st</sup> year. The difference arises in the 2<sup>nd</sup> year because interest of 1<sup>st</sup> year is added in principal and interest is now charged on principal + simple interest of 1<sup>st</sup> year.

### So in this question

$$2 \text{ year SI} = \text{ksh. } 50$$

$$1 \text{ year SI} = \text{ksh. } 25$$

$$\text{Now CI for } 1^{\text{st}} \text{ year} = 52 - 25 = \text{Rs. } 27$$

This additional interest 27 -25 = ksh. 2 is due to the fact that 1<sup>st</sup> year SI i.e. ksh. 25 is added in principal. It means that additional ksh. 2 interest is charged on ksh. 25. Rate % =  $2/25 \times 100 = 8\%$

### Shortcut:

$$\begin{aligned}
 \text{Rate \%} &= [(CI - SI) / (SI/2)] \times 100 \\
 &= [(2/50)/2] \times 100
 \end{aligned}$$

$$2/25 \times 100$$

$$= 8\%$$

$$P = SI \times 100/R \times T = 50 \times 100/8 \times 2$$

$$= \text{ksh. } 312.50$$

### Example

A sum of money lent CI amounts in 2 year to ksh. 8820 and in 3 years to ksh. 9261. Find the sum and rate %.

### Solution.

Amount after 3 years = ksh. 9261

Amount after 2 years = ksh. 8820

By subtracting last year's interest ksh. 441

It is clear that this ksh. 441 is SI on ksh. 8820 from 2<sup>nd</sup> to 3<sup>rd</sup> year i.e. for 1 year.

$$\text{Rate \%} = 441 \times 100/8820 \times 1$$

$$= 5 \%$$

$$\text{Also } A = P (1 + r/100)^t$$

$$8820 = P (1 + 5/100)^2$$

$$= P (21/20)^2$$

$$P = 8820 \times 400/441$$

$$= \text{ksh. } 8000$$

## Appreciation and Depreciation

Appreciation is the gain of value of an asset while depreciation is the loss of value of an asset.

### Example

An iron box cost ksh 500 and every year it depreciates by 10% of its value at the beginning of that that year. What will its value be after value 4 years?

### Solution

$$\text{Value after the first year} = \text{sh } (500 - \frac{10}{100} \times 500)$$

$$= \text{sh } 450$$

$$\begin{aligned} \text{Value after the second year} &= \text{sh } (450 - \frac{10}{100} \times 450) \\ &= \text{sh } 405 \end{aligned}$$

$$\begin{aligned} \text{Value after the third year} &= \text{sh } (405 - \frac{10}{100} \times 405) \\ &= \text{sh } 364.50 \end{aligned}$$

$$\begin{aligned} \text{Value after the fourth year} &= \text{sh } (364.50 - \frac{10}{100} \times 364.50) \\ &= \text{sh } 328.05 \end{aligned}$$

In general if P is the initial value of an asset, A the value after depreciation for n periods and r the rate of depreciation per period.

$$A = P \left( 1 - \frac{r}{100} \right)^n$$

### Example

A minibus cost sh 400000. Due to wear and tear, it depreciates in value by 2 % every month. Find its value after one year,

### Solution

$$A = P \left( 1 - \frac{r}{100} \right)^n$$

Substituting P= 400,000 , r = 2 , and n =12 in the formula ;

$$\begin{aligned} A &= \text{sh.}400000 (1 - 0.02)^{12} \\ &= \text{sh.}400,000(0.98)^{12} \\ &= \text{sh.}313700 \end{aligned}$$

### Example

The initial cost of a ranch is sh.5000, 000. At the end of each year, the land value increases by 2%. What will be the value of the ranch at the end of 3 years?

### Solution

$$\begin{aligned} \text{The value of the ranch after 3 years} &= \text{sh } 5000,000 \left( 1 + \frac{2}{100} \right)^3 \\ &= \text{sh. } 5000000(1.02)^3 \\ &= \text{sh } 5,306,040 \end{aligned}$$

## Hire Purchase

Method of buying goods and services by instalments. The interest charged for buying goods or services on credit is called carrying charge.

$$\text{Hire purchase} = \text{Deposit} + (\text{instalments} \times \text{time})$$

### Example

Aching wants to buy a sewing machine on hire purchase. It has a cash price of ksh 7500. She can pay a cash price or make a down payment of sh 2250 and 15 monthly instalments of sh.550 each. How much interest does she pay under the instalment plan?

### Solution

$$\begin{aligned}\text{Total amount of instalments} &= \text{sh } 550 \times 15 \\ &= \text{sh } 8250\end{aligned}$$

$$\text{Down payment (deposit)} = \text{sh } 2250$$

$$\begin{aligned}\text{Total payment} &= \text{sh } (8250 + 2250) \\ &= \text{sh } 10500\end{aligned}$$

$$\begin{aligned}\text{Amount of interest charged} &= \text{sh } (10500 - 7500) \\ &= \text{sh } 3000\end{aligned}$$

### Note;

Always use the above formula to find other variables.

## Income tax

Taxes on personal income is income tax. Gross income is the total amount of money due to the individual at the end of the month or the year.

$$\text{Gross income} = \text{salary} + \text{allowances} / \text{benefits}$$

Taxable income is the amount on which tax is levied. This is the gross income less any special benefits on which taxes are not levied. Such benefits include refunds for expenses incurred while one is on official duty.

In order to calculate the income tax that one has to pay, we convert the taxable income into Kenya pounds K£ per annum or per month as dictated by the by the table of rates given.

### Relief

- Every employee in kenya is entitled to an automatic personal tax relief of sh.12672 p.a (sh.1056 per month)
- An employee with a life insurance policy on his life, that of his wife or child, may make a tax claim on the premiums paid towards the policy at sh.3 per pound subject to a maximum claim of sh .3000

per month.

**Example**

Mr. John earns a total of K£12300 p.a. Calculate how much tax he should pay per annum. Using the tax table below.

Income tax K£ per annum	Rate (sh per pound)
1 -5808	2
5809 - 11280	3
11289 - 16752	4
16753 - 22224	5
Excess over 22224	6

**Solution**

His salary lies between £ 1 and £12300. The highest tax band is therefore the third band.

For the first £ 5808, tax due is sh  $5808 \times 2 = \text{sh } 11616$

For the next £ 5472, tax due is sh  $5472 \times 2 = \text{sh } 16416$

Remaining £ 1020, tax due sh.  $1020 \times 4 = \text{sh } 4080 +$

Total tax due sh 32112

Less personal relief of sh.  $1056 \times 12 = \text{sh. } 12672 -$

Sh 19440

Therefore payable p.a is sh.19400.

**Example**

Mr. Ogembo earns a basic salary of sh 15000 per month. In addition he gets a medical allowance of sh 2400 and a house allowance of sh 12000. Use the tax table above to calculate the tax he pays per year.

**Solution**

Taxable income per month = sh  $(15000 + 2400 + 12000)$

= sh.29400

Converting to K£ p.a = K£  $29400 \times \frac{12}{20}$

= K£ 17640

Tax due

First £ 5808 = sh.  $5808 \times 2 = \text{sh. } 11616$

Next £ 5472 = sh.  $5472 \times 3 = \text{sh. } 16416$

Next £ 5472 = sh.5472 x 4 = sh.21888  
Remaining £ 888 = sh.888 x 5 = sh 4440 +  
 Total tax due sh 54360  
Less personal relief sh 12672 -  
 Therefore, tax payable p.a sh41688

## PAYE

In Kenya, every employer is required by the law to deduct income tax from the monthly earnings of his employees every month and to remit the money to the income tax department. This system is called Pay As You Earn (PAYE).

## Housing

If an employee is provided with a house by the employer (either freely or for a nominal rent) then 15% of his salary is added to his salary (less rent paid) for purpose of tax calculation. If the tax payer is a director and is provided with a free house, then 15% of his salary is added to his salary before taxation.

### Example

Mr. Omondi who is a civil servant lives in government house who pays a rent of sh 500 per month. If his salary is £9000 p.a, calculate how much PAYE he remits monthly.

Solution

Basic salary	£ 9000
Housing £ $\frac{15}{100}$ x 9000 =	£1350
Less rent paid =	<u>£ 300</u>
<u>£ 1050 +</u>	
Taxable income	£ 10050

### Tax charged;

First £ 5808, the tax due is sh.5808 x 2 =	sh 11616
Remaining £ 4242, the tax due is sh 4242 x 3 =	<u>sh 12726 +</u>
	Sh 24342
Less personal relief	<u>Sh 12672</u>
	Sh 11670



$$\text{PAYE} = \text{sh } \frac{11670}{12}$$

$$= \text{sh } 972.50$$

### Example

Mr. Odhiambo is a senior teacher on a monthly basic salary of Ksh. 16000. On top of his salary he gets a house allowance of sh 12000, a medical allowance of Ksh.3060 and a hardship allowance of Ksh 3060 and a hardship allowance of Ksh.4635. He has a life insurance policy for which he pays Ksh.800 per month and claims insurance relief.

- i. Use the tax table below to calculate his PAYE.

Income in £ per month	Rate %
1 - 484	10
485 - 940	15
941 - 1396	20
1397 - 1852	25
Excess over 1852	30

- ii. In addition to PAYEE the following deductions are made on his pay every month

- WCPS at 2% of basic salary
- HHIF ksh.400
- Co – operative shares and loan recovery Ksh 4800.

### Solution

- a) Taxable income = Ksh (16000 + 12000 + 3060 + 4635)

$$= \text{ksh } 35695$$

$$\text{Converting to K£} = \frac{\text{K£ } 35695}{20}$$

$$= \text{K£ } 1784.75$$

Tax charged is:

$$\text{First £ } 484 = \text{£}484 \times \frac{10}{100} = \text{£ } 48.40$$

$$\text{Next £ } 456 = \text{£}456 \times \frac{15}{100} = \text{£ } 68.40$$

$$\text{Next } \pounds 456 = \pounds 456 \times \frac{10}{100} = \pounds 91.20$$

$$\text{Remaining } \pounds 388 = \pounds 388 \times \frac{25}{100} = \pounds 97.00.$$

$$\begin{aligned} \text{Total tax due} &= \pounds 305.00 \\ &= \text{sh } 6100 \end{aligned}$$

$$\text{Insurance relief} = \text{sh } \frac{800}{20} \times 3 = \text{sh } 120$$

$$\text{Personal relief} \quad \quad \quad = \text{sh } 1056 +$$

$$\text{Total relief} \quad \quad \quad \underline{\text{sh } 1176}$$

Tax payable per month is sh 6100

$$\underline{\text{Sh } 1176} -$$

$$\text{Sh } 4924$$

Therefore, PAYE is sh 4924.

**Note;**

For the calculation of PAYE, taxable income is rounded down or truncated to the nearest whole number.

If an employee's due tax is less than the relief allocated, then that employee is exempted from PAYEE

b) Total deductions are

$$\text{Sh } \left( \frac{2}{100} \times 16000 + 400 + 4800 + 800 + 4924 \right) = \text{sh } 11244$$

$$\text{Net pay} = \text{sh } (35695 - 11244)$$

$$= \text{sh } 24451$$

End of topic

Did you understand everything?

If not ask a teacher, friends or anybody and make sure you understand before going to sleep!

## Past KCSE Questions on the topic.

1. A business woman opened an account by depositing Kshs. 12,000 in a bank on 1<sup>st</sup> July 1995. Each subsequent year, she deposited the same amount on 1<sup>st</sup> July. The bank offered her 9% per annum compound interest. Calculate the total amount in her account on

- (a) 30<sup>th</sup> June 1996
- (b) 30<sup>th</sup> June 1997

2. A construction company requires to transport 144 tonnes of stones to sites A and B. The company pays Kshs 24,000 to transport 48 tonnes of stone for every 28 km. Kimani transported 96 tonnes to a site A, 49 km away.

- (a) Find how much he paid
- (b) Kimani spends Kshs 3,000 to transport every 8 tonnes of stones to site.

Calculate his total profit.

- (c) Achieng transported the remaining stones to sites B, 84 km away. If she made 44% profit, find her transport cost.

3. The table shows income tax rates

Monthly taxable pay	Rate of tax Kshs in 1 K£
1 – 435	2
436 – 870	3
871-1305	4
1306 – 1740	5
Excess Over 1740	6

A company employee earn a monthly basic salary of Kshs 30,000 and is also given taxable allowances amounting to Kshs 10, 480.

- (a) Calculate the total income tax
- (b) The employee is entitled to a personal tax relief of Kshs 800 per month.  
Determine the net tax.
- (c) If the employee received a 50% increase in his total income, calculate the corresponding percentage increase on the income tax.

4. A house is to be sold either on cash basis or through a loan. The cash price is Kshs.750, 000. The loan conditions are as follows: there is to be down payment of 10% of the cash price and the rest of the money is to be paid through a loan at 10% per annum compound interest.

A customer decided to buy the house through a loan.

- a) (i) Calculate the amount of money loaned to the customer.
- (ii) The customer paid the loan in 3 year's. Calculate the total amount

paid for the house.

- b) Find how long the customer would have taken to fully pay for the house if she paid a total of Kshs 891,750.

5. A businessman obtained a loan of Kshs. 450,000 from a bank to buy a matatu valued at the same amount. The bank charges interest at 24% per annum compound quarterly

- a) Calculate the total amount of money the businessman paid to clear the loan in 1 ½ years.  
 b) The average income realized from the matatu per day was Kshs. 1500. The matatu worked for 3 years at an average of 280 days year. Calculate the total income from the matatu.  
 c) During the three years, the value of the matatu depreciated at the rate of 16% per annum. If the businessman sold the matatu at its new value, calculate the total profit he realized by the end of three years.

6. A bank either pays simple interest as 5% p.a or compound interest 5% p.a on deposits. Nekesa deposited Kshs P in the bank for two years on simple interest terms. If she had deposited the same amount for two years on compound interest terms, she would have earned Kshs 210 more.

Calculate without using Mathematics Tables, the values of P

7. (a) A certain sum of money is deposited in a bank that pays simple interest at a certain rate. After 5 years the total amount of money in an account is Kshs 358 400. The interest earned each year is 12 800

Calculate

- (i) The amount of money which was deposited (2mks)  
 (ii) The annual rate of interest that the bank paid (2mks)  
 (b) A computer whose marked price is Kshs 40,000 is sold at Kshs 56,000 on hire purchase terms.  
 (i) Kioko bought the computer on hire purchase term. He paid a deposit of 25% of the hire purchase price and cleared the balance by equal monthly installments of Kshs 2625. Calculate the number of installments(3mks)  
 (ii) Had Kioko bought the computer on cash terms he would have been allowed a discount of 12 ½ % on marked price. Calculate the difference between the cash price and the hire purchase price and express as a percentage of the cash price  
 (iii) Calculate the difference between the cash price and hire purchase price and express it as a percentage of the cash price.

8. The table below is a part of tax table for monthly income for the year 2004

Monthly taxable income In ( Kshs)	Tax rate percentage (%) in each shillings
Under Kshs 9681	10%
From Kshs 9681 but under 18801	15%

From Kshs 18801 but 27921	20%
---------------------------	-----

In the tax year 2004, the tax of Kerubo's monthly income was Kshs 1916.

Calculate Kerubo's monthly income

9. The cash price of a T.V set is Kshs 13, 800. A customer opts to buy the set on hire purchase terms by paying a deposit of Kshs 2280.

If simple interest of 20 p. a is charged on the balance and the customer is required to repay by 24 equal monthly installments. Calculate the amount of each installment.

10. A plot of land valued at Ksh. 50,000 at the start of 1994.

Thereafter, every year, it appreciated by 10% of its previous years value find:

- (a) The value of the land at the start of 1995  
(b) The value of the land at the end of 1997

11. The table below shows Kenya tax rates in a certain year.

Income K £ per annum	Tax rates Kshs per K £
1- 4512	2
4513 - 9024	3
9025 - 13536	4
13537 - 18048	5
18049 - 22560	6
Over 22560	6.5

In that year Muhando earned a salary of Ksh. 16510 per month. He was entitled to a monthly tax relief of Ksh. 960

Calculate

- (a) Muhando annual salary in K £  
(b) (i) The monthly tax paid by Muhando in Ksh
14. A tailor intends to buy a sewing machine which costs Ksh 48,000. He borrows the money from a bank. The loan has to be repaid at the end of the second year. The bank charges an interest at the rate of 24% per annum compounded half yearly. Calculate the total amount payable to the bank.
15. The average rate of depreciation in value of a water pump is 9% per annum. After three complete years its value was Ksh 150,700. Find its value at the start of the three year period.

1. A water pump costs Ksh 21600 when new, at the end of the first year its value depreciates by 25%. The depreciation at the end of the second year is 20% and thereafter the rate of depreciation is 15% yearly. Calculate the exact value of the water pump at the end of the fourth year.

## CHAPTER FOURTY SEVEN

### CIRCLES, CHORDS AND TANGENTS

#### Specific Objectives

By the end of the topic the learner should be able to:

- (a) Calculate length of an arc and a chord;
- (b) Calculate lengths of tangents and intersecting chords;
- (c) State and use properties of chords and tangents;
- (d) Construct tangent to a circle,
- (e) Construct direct and transverse common tangents to two circles;
- (f) Relate angles in alternate segment;
- (g) Construct circumscribed, inscribed and escribed circles;
- (h) Locate centroid and orthocentre of a triangle;
- (i) Apply knowledge of circles, tangents and chords to real life situations.

#### Content

- (a) Arcs, chords and tangents
- (b) Lengths of tangents and intersecting chords
- (c) Properties of chords and tangents
- (d) Construction of tangents to a circle
- (e) Direct and transverse common tangents to two circles
- (f) Angles in alternate segment

- (g) Circumscribed, inscribed and escribed circles
- (h) Centroid and orthocentre
- (i) Application of knowledge of tangents and chords to real life situations.

### Length of an Arc

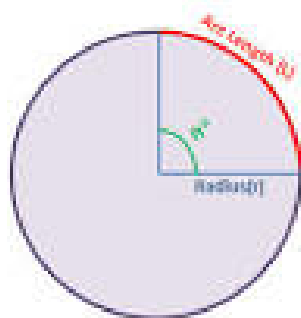

The Arc length marked red is given by ;

$$\frac{\theta}{360} \times 2\pi r.$$

#### Example

Find the length of an arc subtended by an angle of  $250^\circ$  at the centre of the circle of radius 14 cm.

#### Solution

$$\begin{aligned} \text{Length of an arc} &= \frac{\theta}{360} \times 2\pi r \\ &= \frac{250}{360} \times 2 \times \frac{22}{7} \times 14 = 61.11 \text{ cm} \end{aligned}$$

#### Example

The length of an arc of a circle is 11.0 cm. Find the radius of the circle if an arc subtended an angle of  $90^\circ$  at the centre .

#### Solution

$$\text{Arc length} = \frac{\theta}{360} \times 2\pi r \quad \text{but } \theta = 90^\circ$$

$$\text{Therefore } 11 = \frac{90}{360} \times 2 \times \frac{22}{7} \times r$$

$$r = 7.0 \text{ cm}$$

**Example**

Find the angle subtended at the centre of a circle by an arc of 20 cm, if the circumference of the circle is 60 cm.

Solution

$$= \frac{\theta}{360} \times 2\pi r = 20$$

But  $2\pi r = 60$  cm

Therefore,  $\frac{\theta}{360} \times 60 = 20$

$$\theta = 20 \times \frac{360}{60}$$

$$\theta = 120^\circ$$

**Chords**

Chord of a circle: A line segment which joins two points on a circle. Diameter: a chord which passes through the center of the circle. Radius: the distance from the center of the circle to the circumference of the circle

**Perpendicular bisector of a chord**

A perpendicular drawn from the centre of the circle to a chord bisects the chord.

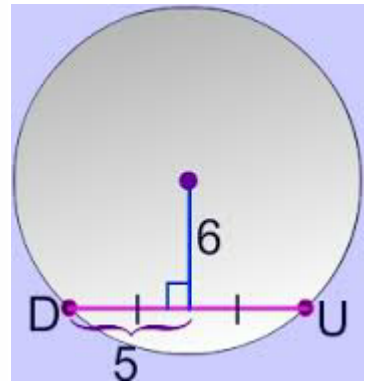
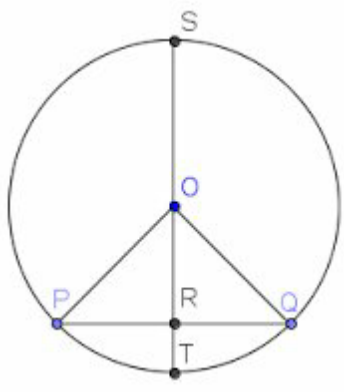

**Note;**

- Perpendicular drawn from the centre of the circle to chord bisects the chord (divides it into two equal parts)
- A straight line joining the centre of a circle to the midpoint of a chord is perpendicular to the chord.

For free KCSE Notes, Exams, and Past Papers Visit <https://Teacher.co.ke/>



The radius of a circle centre O is 13 cm. Find the perpendicular distance from O to the chord, if AB is 24 cm.

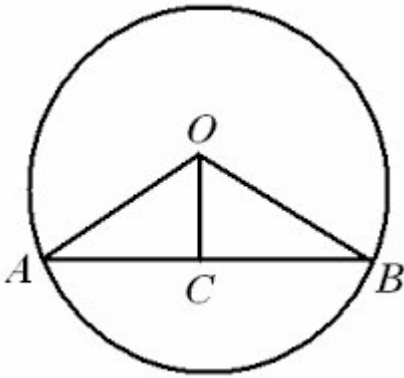

**Solution**

OC bisects chord AB at C

Therefore, AC = 12 cm

In  $\Delta AOC$ ,  $OC^2 = AO^2 - AC^2$

$$= 13^2 - 12^2 = 25$$

Therefore

$$OC = \sqrt{25} = 5 \text{ cm}$$

**Parallel chords**

Any chord passing through the midpoints of all parallel chords of a circle is a diameter

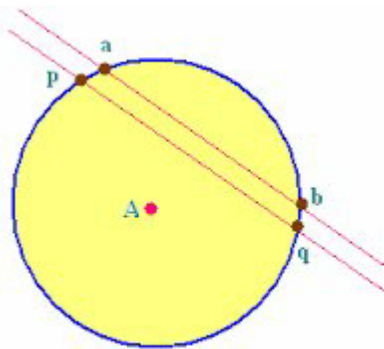

Structure of parallel chord

**Example**

In the figure below CD and AB are parallel chords of a circle and 2 cm apart. If CD = 8 cm and AB = 10 cm, find the radius of the circle

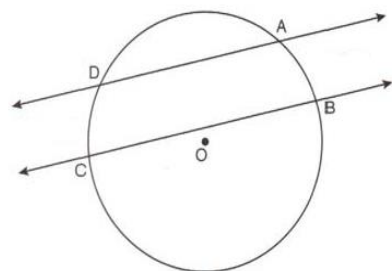

**Solution**

- Draw the perpendicular bisector of the chords to cut them at K and L .
- Join OD and OC
- In triangle ODL,
- $DL = 4$  cm and  $KC = 5$  cm
- Let  $OK = X$  cm
- Therefore  $(x + 2)^2 + 4^2 = r^2$

In triangle OCK;

- $x^2 + 5^2 = r^2$
- Therefore  $(x + 2)^2 + 4^2 = x^2 + 5^2$
- $x^2 + 4x + 20 + 4^2 = x^2 + 5^2$
- $4x + 20 = 25$
- $4x = 5$
- $X = 1 \frac{1}{4}$

Using the equation  $x^2 + 5^2 = r^2$

$$r^2 = \left(\frac{5}{4}\right)^2 + 5^2$$

$$= \frac{25}{16} + 25$$

$$= \frac{425}{16}$$

$$r = \sqrt{\frac{425}{16}} = 5.154 \text{ cm}$$

2. A hemispherical pot is used for a hanging basket. The width of the surface of the soil is 30cm. The maximum depth of the soil is 10 cm. Find the radius of the pot.

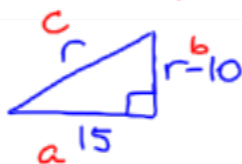
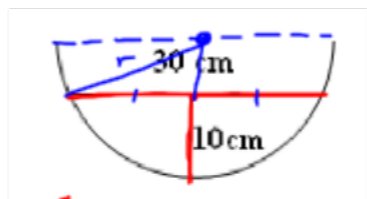

$$c^2 = a^2 + b^2 \quad \rightarrow (r-10)(r-10) \text{ FOIL}$$

$$r^2 = 15^2 + (r-10)^2$$

$$\cancel{r^2} = 225 + \cancel{r^2} - 20r + 100$$

$$\frac{20r}{20} = \frac{325}{20}$$

$$r = \boxed{16.25 \text{ cm}}$$

### Intersecting chords

In general  $\frac{DE}{AE} = \frac{EB}{EC}$  or  $DE \times EC = EB \times AE$

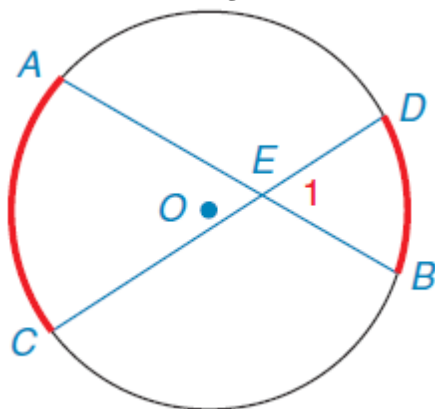

### Example

In the example above AB and CD are two chords that intersect in a circle at E. Given that AE = 4 cm, CE = 5 cm and DE = 3 cm, find AB.

**Solution**

Let  $EB = x$  cm

$$4 \times x = 5 \times 3$$

$$4x = 15$$

$$x = 3.75 \text{ cm}$$

Since  $AB = AE + EB$   
 $AB = 4 + 3.75$   
 $= 7.75 \text{ cm}$

**Equal chords.**

- Angles subtended at the centre of a circle by equal chords are equal
- If chords are equal they are equidistant from the centre of the circle

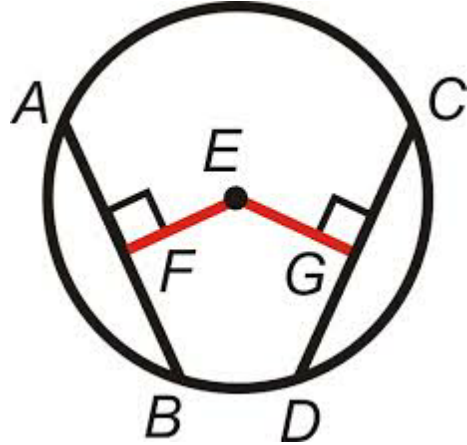
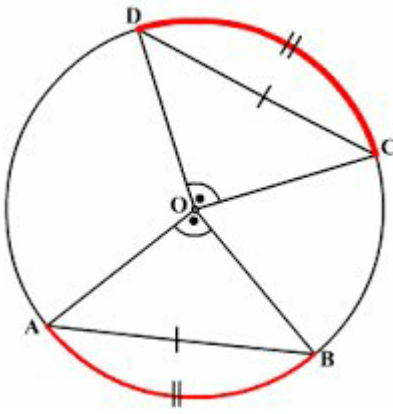

**Secant**

A chord that is produced outside a circle is called a secant

$$\frac{BC}{EC} = \frac{CD}{CA} \quad \text{OR} \quad BC \times CA = CD \times EC$$

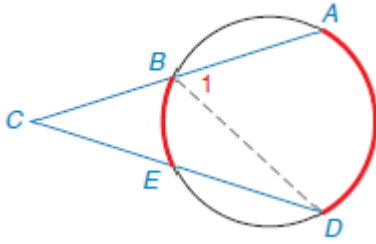

**Example**

Find the value of AT in the figure below.  $AR = 4$  cm,  $RD = 5$  cm and  $TC = 9$  cm.

**Solution**

$$AC \times AT = AO \times AR$$

$$(x + 9) \times x = (5 + 4) \times 4$$

isabokemicah@gmail.com

$$x^2 + 9x = 36$$

$$x^2 + 9x - 36 = 0$$

$$(x + 12)(x - 3) = 0$$

Therefore,  $x = -12$  or  $x = 3$

$x$  can only be a positive number not negative hence  $x = 3$  cm

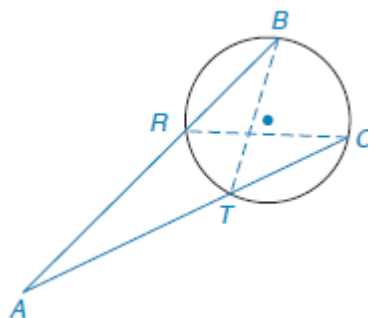

## Tangent and secant

### Tangent

A line which touches a circle at exactly one point is called a tangent line and the point where it touches the circle is called the point of contact

### Secant

A line which intersects the circle in two distinct points is called a secant line (usually referred to as a secant). The figures below A shows a secant while B shows a tangent.

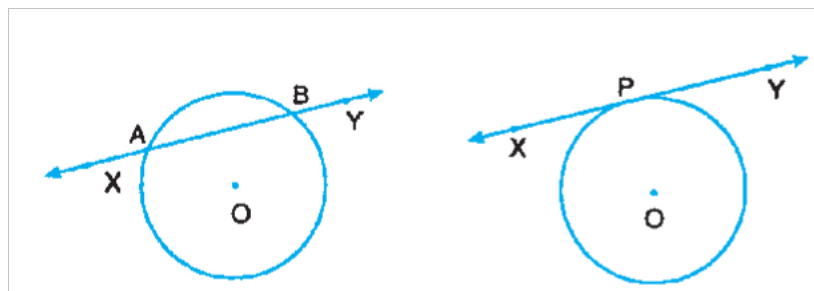

A

B

### Construction of a tangent

- Draw a circle of any radius and centre O.
- Join O to any point P on the circumference
- Produce OP to a point P outside the circle
- Construct a perpendicular line SP through point P
- The line is a tangent to the circle at P as shown below.

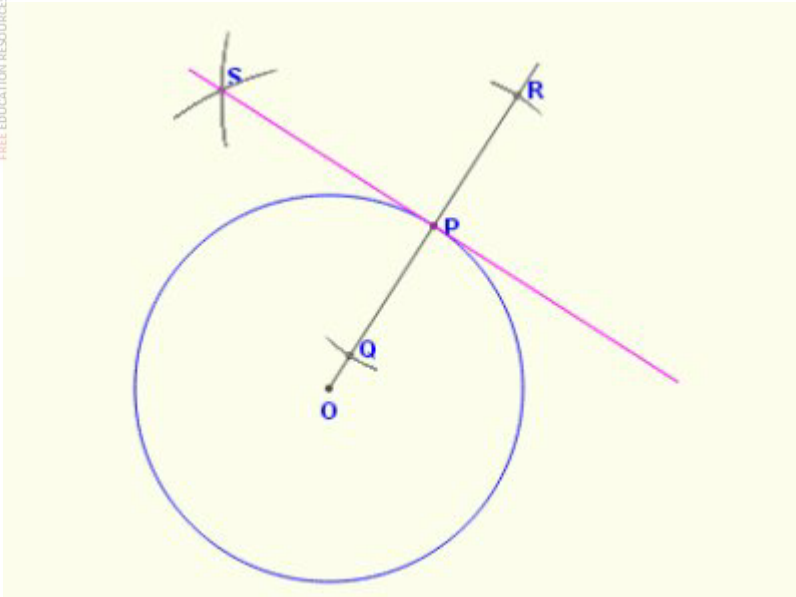

**Note;**

- The radius and tangent are perpendicular at the point of contact.
- Through any point on a circle, only one tangent can be drawn
- A perpendicular to a tangent at the point of contact passes through the centre of the circle.

**Example**

In the figure below  $PT = 15\text{ cm}$  and  $PO = 17\text{ cm}$ , calculate the length of  $PQ$ .

**Solution**

$$\begin{aligned}
 OT^2 &= OP^2 - PT^2 \\
 &= 17^2 - 15^2 \\
 &= 64
 \end{aligned}$$

$$OT = 8\text{ cm}$$

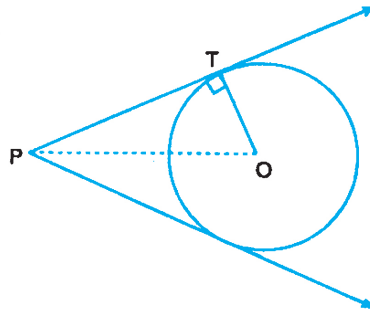

**Properties of tangents to a circle from an external point**

If two tangents are drawn to a circle from an external point

- They are equal
- They subtend equal angles at the centre
- The line joining the centre of the circle to the external point bisects the angle between the tangents

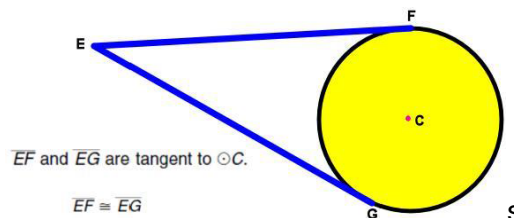
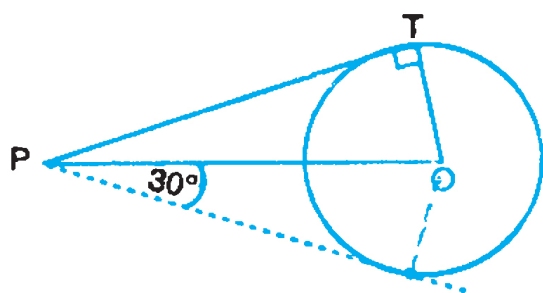

**Example**

The figure below represents a circle centre O and radius 5 cm. The tangents PT is 12 cm long. Find: a.) OP  
b.) Angle TPT<sup>1</sup>

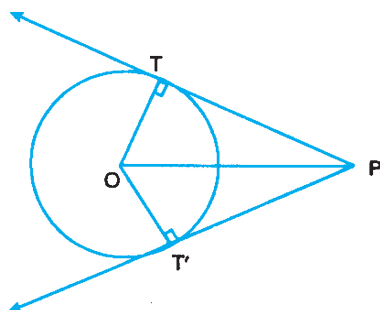

**Solution**

a.) Join O to P

$$OP^2 = OC^2 - PC^2 \text{ (pythagoras theorem)}$$

$$OP^2 = 5^2 + 12^2$$

$$= 25 + 144$$

$$= 169$$

Therefore, OP = 13 cm

b.)  $\angle TPT^1 = 2 \angle TPO$  ( PO bisect  $\angle TPT^1$ )

$$\angle OTP = 90^0$$

$\Delta TPO$  is a right angled at T

isabokemicah@gmail.com

$$\cos \angle TPO = \frac{12}{13} = 0.9231$$

Therefore,  $\angle TPO = 22.62^\circ$

$$\begin{aligned} \text{Hence } \angle TPT^1 &= 22.62^\circ \times 2 \\ &= 45.24^\circ \end{aligned}$$

## Two tangent to a circle

Direct (exterior) common tangents

Transverse or interior common tangents



## Tangent Problem

The common-tangent problem is named for the single tangent segment that's tangent to two circles. Your goal is to find the length of the tangent. These problems are a bit involved, but they should cause you little difficulty if you use the straightforward three-step solution method that follows.

The following example involves a common external tangent (where the tangent lies on the same side of both circles). You might also see a common-tangent problem that involves a common internal tangent (where the tangent lies between the circles). No worries: The solution technique is the same for both.

Given the radius of circle A is 4 cm and the radius of circle Z is 14 cm and the distance between the two circles is 8 cm.

Here's how to solve it:

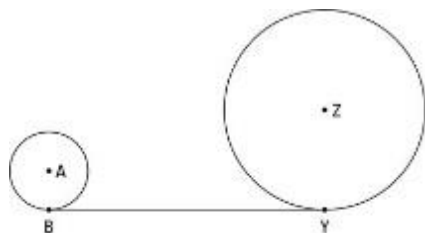

1.) Draw the segment connecting the centers of the two circles and draw the two radii to the points of tangency (if these segments haven't already been drawn for you).

Draw line AZ and radii AB and ZY.

The following figure shows this step. Note that the given distance of 8 cm between the circles is the distance between the outsides of the circles along the segment that connects their centers.



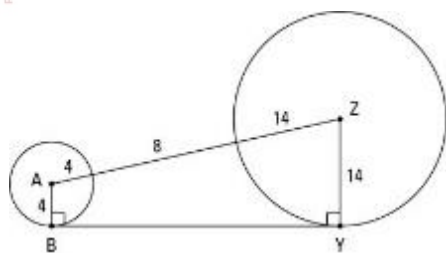

2.) From the center of the smaller circle, draw a segment parallel to the common tangent till it hits the radius of the larger circle (or the extension of the radius in a common-internal-tangent problem).

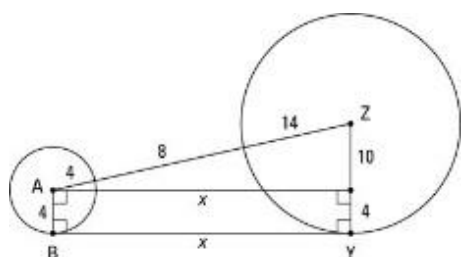

You end up with a right triangle and a rectangle; one of the rectangle's sides is the common tangent. The above figure illustrates this step.

3.) You now have a right triangle and a rectangle and can finish the problem with the Pythagorean Theorem and the simple fact that opposite sides of a rectangle are congruent.

The triangle's hypotenuse is made up of the radius of circle A, the segment between the circles, and the radius of circle Z. Their lengths add up to  $4 + 8 + 14 = 26$ . You can see that the width of the rectangle equals the radius of circle A, which is 4; because opposite sides of a rectangle are congruent, you can then tell that one of the triangle's legs is the radius of circle Z minus 4, or  $14 - 4 = 10$ .

You now know two sides of the triangle, and if you find the third side, that'll give you the length of the common tangent.

You get the third side with the Pythagorean Theorem:

$$x^2 + 10^2 = 26^2$$

$$x^2 + 100 = 676$$

$$x^2 = 576$$

$$x = 24$$

(Of course, if you recognize that the right triangle is in the 5 : 12 : 13 family, you can multiply 12 by 2 to get 24 instead of using the Pythagorean Theorem.) Because opposite sides of a rectangle are congruent, BY is also 24, and you're done.

Now look back at the last figure and note where the right angles are and how the right triangle and the rectangle are situated; then make sure you heed the following tip and warning.

Note the location of the hypotenuse. In a common-tangent problem, the segment connecting the centers of the circles is always the hypotenuse of a right triangle. The common tangent is always the side of a rectangle, not a hypotenuse.

In a common-tangent problem, the segment connecting the centers of the circles is never one side of a right angle. Don't make this common mistake.

## HOW TO construct a common exterior tangent line to two circles

In this lesson you will learn how to construct a common exterior tangent line to two circles in a plane such that no one is located inside the other using a ruler and a compass.

### Problem 1

For two given circles in a plane such that no one is located inside the other, to construct the common exterior tangent line using a ruler and a compass.

### Solution

We are given two circles in a plane such that no one is located inside the other (Figure 1a).

We need to construct the common exterior tangent line to the circles using a ruler and a compass.

First, let us analyze the problem and make a sketch (Figures 1a and 1b). Let AB be the common tangent line to the circles we are searching for.

Let us connect the tangent point A of the first circle with its center P and the tangent point B of the second circle with its center Q (Figure 1a and 1b).

Then the radii PA and QB are both perpendicular to the tangent line AB (lesson A tangent line to a circle is perpendicular to the radius drawn to the tangent point under the topic Circles and their properties ).

Hence, the radii PA and QB are parallel.

Figure 1a. To the Problem 1

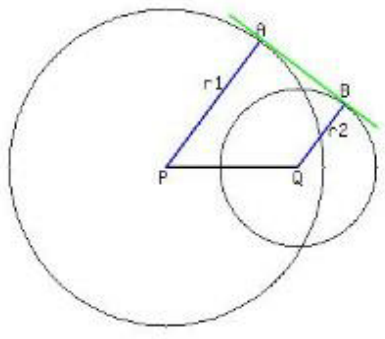

Figure 1b. To the solution of the Problem 1

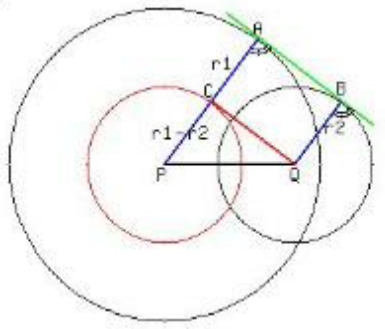
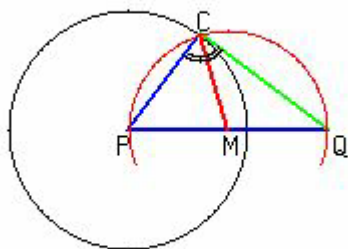

Figure 1c. To the construction step 3



Next, let us draw the straight line segment  $CQ$  parallel to  $AB$  through the point  $Q$  till the intersection with the radius  $PA$  at the point  $C$  (Figure 1b). Then the straight line  $CQ$  is parallel to  $AB$ . Hence, the quadrilateral  $CABQ$  is a parallelogram (moreover, it is a rectangle) and has the opposite sides  $QB$  and  $CA$  congruent. The point  $C$  divides the radius  $PA$  in two segments of the length  $r_2$  ( $CA$ ) and  $r_1 - r_2$  ( $PC$ ). It is clear from this analysis that the straight line  $QC$  is the tangent line to the circle of the radius  $r_1 - r_2$  with the center at the point  $P$  (shown in red in Figure 1b).

It implies that the procedure of constructing the common exterior tangent line to two circles should be as follows:

- 1) draw the auxiliary circle of the radius  $r_1 - r_2$  at the center of the larger circle (shown in red in Figure 1b);
- 2) construct the tangent line to this auxiliary circle from the center of the smaller circle (shown in red in Figure 1b). In this way you will get the tangent point  $C$  on the auxiliary circle of the radius  $r_1 - r_2$  ;
- 3) draw the straight line from the point  $P$  to the point  $C$  and continue it in the same direction till the intersection with the larger circle (shown in blue in Figure 1b). The intersection point  $A$  is the tangent point of the common tangent line and the larger circle. Figure 1c reminds you how to perform this step.
- 4) draw the straight line  $QB$  parallel to  $PA$  till the intersection with the smaller circle (shown in blue in Figure 1b).

The intersection point  $B$  is the tangent point of the common tangent line and the smaller circle;

- 5) the required common tangent line is uniquely defined by its two points  $A$  and  $B$ .

Note that all these operations 1) - 4) can be done using a ruler and a compass. The problem is solved.

### Problem 2

Find the length of the common exterior tangent segment to two given circles in a plane, if they have the radii  $r_1$  and  $r_2$  and the distance between their centers is  $d$ .

No one of the two circles is located inside the other.

### Solution

Let us use the Figure 1b from the solution to the previous Problem 1.

This Figure is relevant to the Problem 2. It is copied and reproduced in the Figure 2 on the right for your convenience.

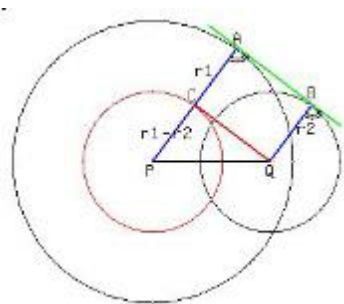

figure 2

It is clear from the solution of the Problem 1 above that the common exterior tangent segment  $|AB|$  is congruent to the side  $|CQ|$  of the quadrilateral (rectangle)  $CABQ$ .

From the other side, the segment  $CQ$  is the leg of the right-angled triangle  $DELTA PCQ$ . This triangle has the hypotenuse's measure  $d$  and the other leg's measure  $r_1 - r_2$ . Therefore, the length of the common exterior tangent segment  $|AB|$  is equal to

$$|AB| = \sqrt{d^2 - (r_1 - r_2)^2}$$

Note that the solvability condition for this problem is  $d > r_1 - r_2$ .

It coincides with the condition that no one of the two circles lies inside the other.

### Example 1

Find the length of the common exterior tangent segment to two given circles in a plane, if their radii are 6 cm and 3 cm and the distance between their centers

is 5 cm.

**Solution**

Use the formula (1) derived in the solution of the Problem 2.

According to this formula, the length of the common exterior tangent segment to the two given circles is equal to

$$\sqrt{5^2 - (6-3)^2} = \sqrt{5^2 - 3^2} = \sqrt{25-9}$$

$$= 4 \text{ cm}$$

**Answer.**

The length of the common exterior tangent segment to the two given circles is 4 cm

**Contact of circles**

Two circle are said to touch each other at a point if they have a common tangent at that point.

Point T is shown by the red dot.

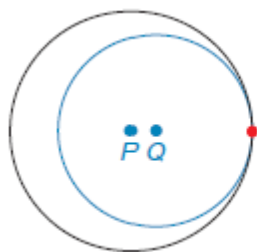

Internal tangent

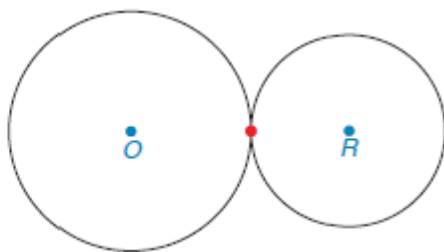

externally tangent

**Note;**

- The centers of the two circles and their point of contact lie on a straight line
- When two circles touch each other internally, the distance between the centers is equal to the difference of the radii i.e.  $PQ = TP - TA$
- When two circles touch each other externally, the distance between the centers is equal to the sum of the radii i.e.  $OR = TO + TR$

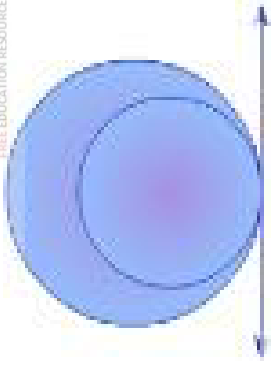

isabokemicah@gmail.com

### Transverse (Interior) Common Tangents

In figure 7.46, P and Q are centres of two circles with radii  $r_1$  and  $r_2$  respectively. Given that  $r_1 > r_2$ , construct the transverse common tangents to both circles.

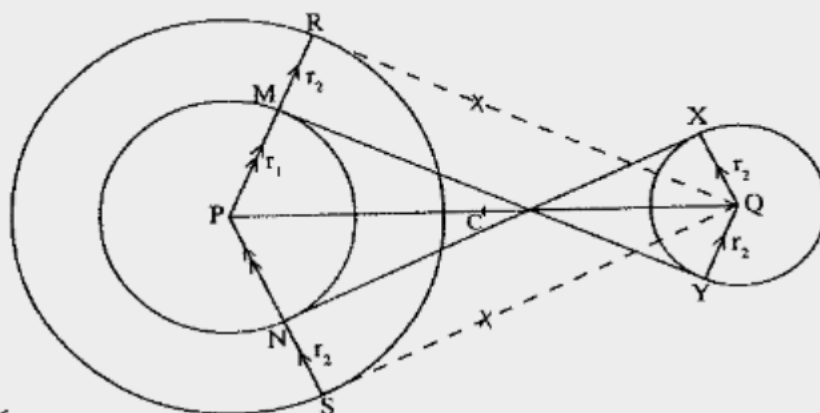

Fig. 7.46

#### Procedure

- (i) With centre P, construct a circle whose radius PR is equal to  $r_1 + r_2$ .
- (ii) Join P to Q and bisect PQ to get point C.
- (iii) With centre C and radius PC, draw arcs to cut the circle whose radius is  $r_1 + r_2$  at R and S. Join Q to R and Q to S.
- (iv) Draw the lines PR and PS to cut the circle whose radius is  $r_1$  at M and N respectively.
- (v) Draw line QX parallel to PS and line QY parallel to PR.
- (vi) Draw lines MY and NX. These are the required transverse (interior) common tangents.

#### Note:

$PR = r_1 + r_2$  (construction).

$PM = r_1$  (given)

$$\therefore RM = PR - PM = (r_1 + r_2) - r_1$$

$$= r_2$$

$$\therefore RM = QY$$

But RM is parallel to QY (construction)

$\therefore$  MRQY is a parallelogram (opposite sides equal and parallel).

QR is tangent to circle radius PR (construction).

$\angle PRQ = 90^\circ$  (radius  $\perp$  tangent).

But  $\angle YQR = 90^\circ$  (interior  $\angle$ s of a parallelogram).

$\therefore$  MRQY is a rectangle.

$\therefore \angle PMY = \angle QYM = 90^\circ$ .

### Alternate Segment theorem

The angle which the chord makes with the tangent is equal to the angle subtended by the same chord in the alternate segment of the circle.



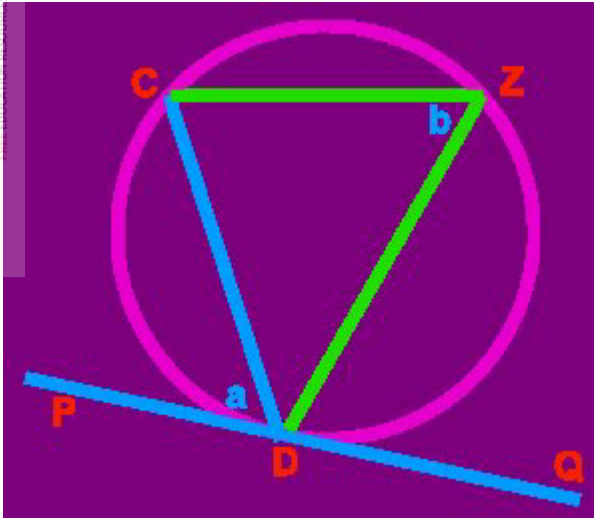

Angle a = Angle b

Note;

The blue line represents the angle which the chord CD makes with the tangent PQ which is equal to the angle b which is subtended by the chord in the alternate segment of the circle.

Illustrations

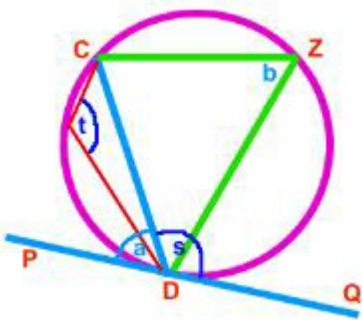

- Angle s = Angle t
- Angle a = Angle b                      we use the alternate segment theorem <

Tangent – secant segment length theorem

If a tangent segment and secant segment are drawn to a circle from an external point, then the square of the length of the tangent equals the product of the length of the secant with the length of its external segment.

For free KCSE Notes, Exams, and Past Papers Visit <https://Teacher.co.ke/>

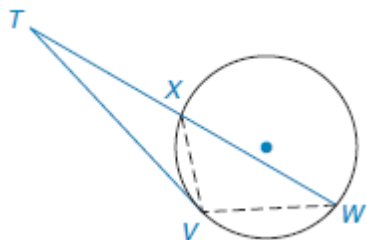

$$(TV)^2 = TW \cdot TX$$

### Example

In the figure above,  $TW=10$  cm and  $XW = 4$  cm. find TV

### Solution

$$(TV)^2 = TW \cdot TX$$

$$(TV)^2 = 10 \times 6 \quad (tx = tw - xw)$$

$$= \sqrt{16}$$

$$TV = 4 \text{ cm}$$

## Circles and triangles

### Inscribed circle

- Construct any triangle ABC.
- Construct the bisectors of the three angles
- The bisectors will meet at point I
- Construct a perpendicular from O to meet one of the sides at M
- With the centre I and radius IM draw a circle
- The circle will touch the three sides of the triangle ABC
- Such a circle is called an inscribed circle or in circle.
- The centre of an inscribed circle is called the incentre

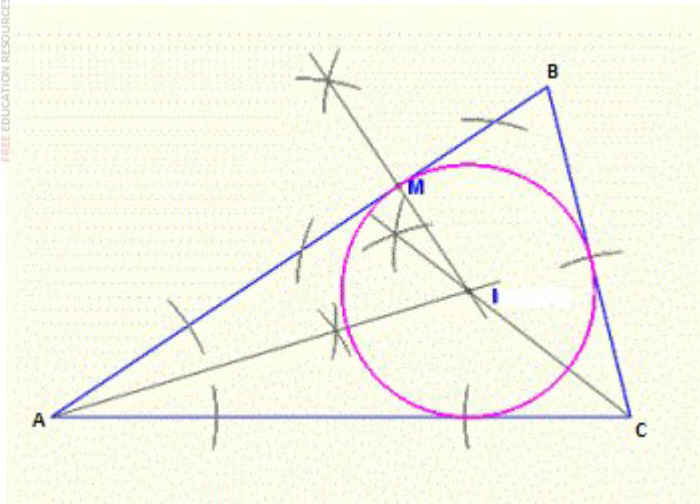

### Circumscribed circle

- Construct any triangle ABC.
- Construct perpendicular bisectors of AB , BC, and AC to meet at point O.
- With O as the centre and using OB as radius, draw a circle
- The circle will pass through the vertices A , B and C as shown in the figure below

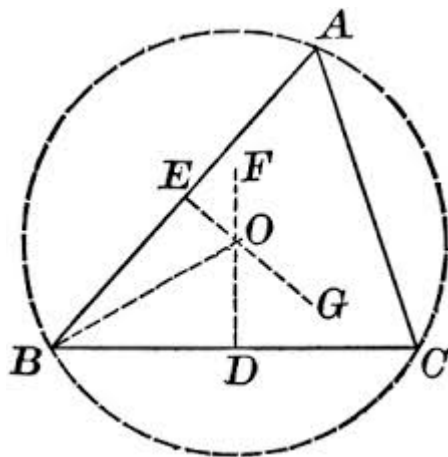

### Escribed circle

- Construct any triangle ABC.
- Extend line BA and BC
- Construct the perpendicular bisectors of the two external angles produced
- Let the perpendicular bisectors meet at O
- With O as the centre draw the circle which will touch all the external sides of the triangle

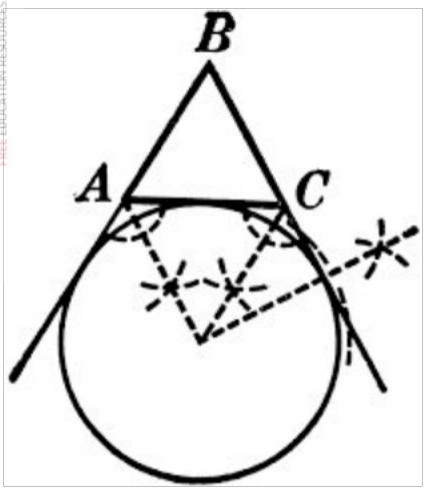

Note;

Centre O is called the ex-centre

AO and CO are called external bisectors.

End of topic

Did you understand everything?  
If not ask a teacher, friends or anybody and make sure you understand before going to sleep!

## Past KCSE Questions on the topic.

- The figure below represents a circle a diameter 28 cm with a sector subtending an angle of  $75^\circ$  at the centre.

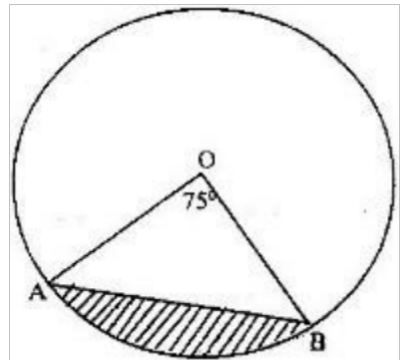

Find the area of the shaded segment to 4 significant figures

(a) <PST

- The figure below represents a rectangle PQRS inscribed in a circle centre O and radius 17 cm. PQ =

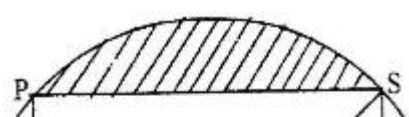

16 cm.

Calculate

- (a) The length PS of the rectangle
- (b) The angle POS
- (c) The area of the shaded region

3. In the figure below, BT is a tangent to the circle at B. AXCT and BXD are straight lines. AX = 6 cm, CT = 8 cm, BX = 4.8 cm and XD = 5 cm.

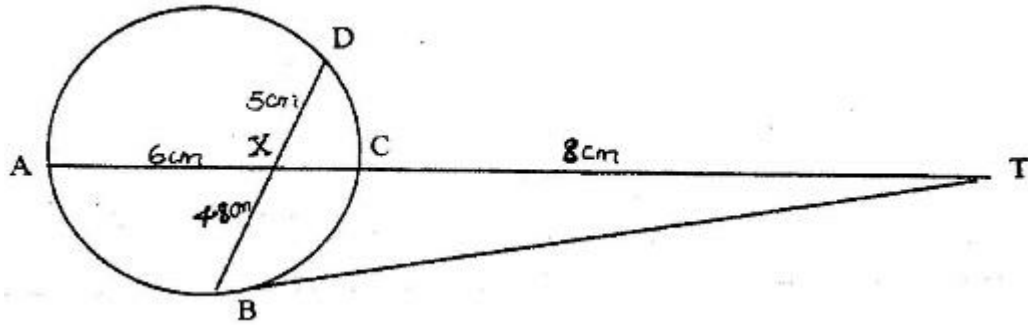

Find the length of

- (a) XC
- (b) BT

4. The figure below shows two circles each of radius 7 cm, with centers at X and Y. The circles touch each other at point Q.

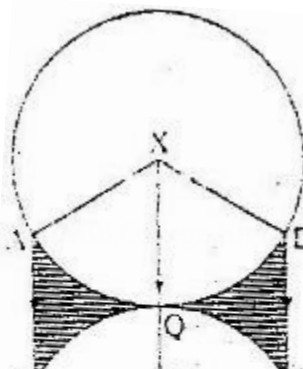

Given that  $\angle AXD = \angle BYC = 120^\circ$  and lines AB, XQY and DC are parallel, calculate the area of:

- Minor sector XAQD (Take  $\pi^{22/7}$ )
- The trapezium XABY
- The shaded regions.

5. The figure below shows a circle, centre, O of radius 7 cm. TP and TQ are tangents to the circle at points P and Q respectively. OT = 25 cm.

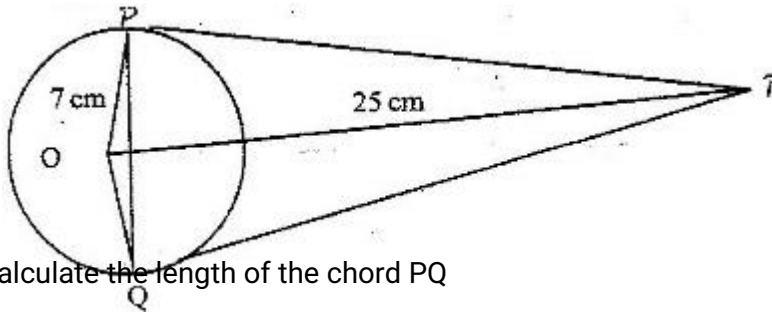

Calculate the length of the chord PQ

6. The figure below shows a circle centre O and a point Q which is outside the circle

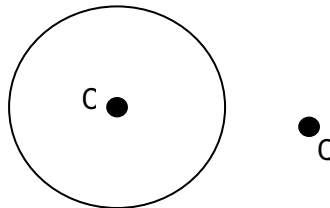

Using a ruler and a pair of compasses, only locate a point on the circle such that angle OPQ =  $90^\circ$

7. In the figure below, PQR is an equilateral triangle of side 6 cm. Arcs QR, PR and PQ arcs of circles with centers at P, Q and R respectively.

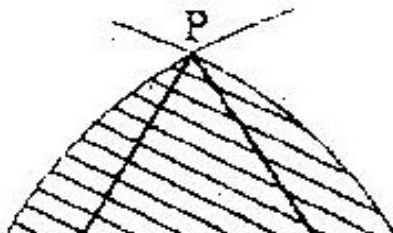

Calculate the area of the shaded region to 4 significant figures

8. In the figure below AB is a diameter of the circle. Chord PQ intersects AB at N. A tangent to the circle at B meets PQ produced at R.

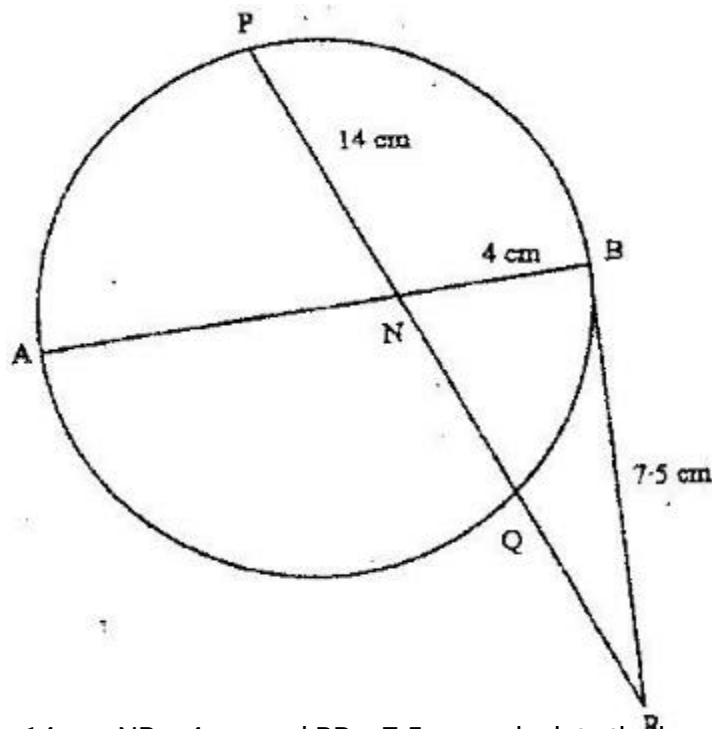

Given that  $PN = 14$  cm,  $NB = 4$  cm and  $BR = 7.5$  cm, calculate the length of:

- (a) NR

(b) AN

Novels, Updated ICT, CPA, KASNEB, College, High School Notes & Revision Booklets 0714497530

## CHAPTER FOURTY EIGHT

### MATRICES

#### Specific Objectives

By the end of the topic the learner should be able to:

- (a) Define a matrix;
- (b) State the order of a matrix;
- (c) Define a square matrix;
- (d) Determine compatibility in addition and multiplication of matrices;
- (e) Add matrices;
- (f) Multiply matrices;
- (g) Identify matrices;
- (h) Find determinant of a  $2 \times 2$  matrix;
- (i) Find the inverse of a  $2 \times 2$  matrix;
- (j) Use matrices to solve simultaneous equations.

#### Content

- (a) Matrix
- (b) Order of a matrix
- (c) Square matrix
- (d) Compatibility in addition and multiplication of matrices
- (e) Multiplication of a matrix by a scalar
- (f) Matrix multiplication



- (g) Identify matrix
- (h) Determinant of a 2 x 2 matrix
- (i) Inverse of a 2 x 2 matrix
- (j) Singular matrix
- (k) Solutions of simultaneous equations in two unknowns.

(i)

## Introduction

A matrix is a rectangular arrangement of numbers in rows and columns. For instance, matrix  $A$  below has two rows and three columns. The dimensions of this matrix are 2 x 3 (read "2 by 3"). The numbers in a matrix are its entries. In matrix  $A$ , the entry in the second row and third column is **5**.

$$A = \begin{bmatrix} 6 & 2 & -1 \\ -2 & 0 & 5 \end{bmatrix}$$

Some *matrices* (the plural of *matrix*) have special names because of their dimensions or entries.

## Order of matrix

Matrix consist of rows and columns. Rows are the horizontal arrangement while columns are the vertical arrangement.

Order of matrix is being determined by the number of rows and columns. The order is given by stating the number of rows followed by columns.

### Note;

If the number of rows is  $m$  and the number of columns  $n$ , the matrix is of order  $m \times n$ .

E.g. If a matrix has  $m$  *rows* and  $n$  *columns*, it is said to be *order*  $m \times n$ .

e.g.  $\begin{bmatrix} 2 & 0 & 3 & 6 \\ 3 & 4 & 7 & 0 \\ 1 & 9 & 2 & 5 \end{bmatrix}$  is a matrix of order  $3 \times 4$ .

e.g.  $\begin{bmatrix} 1 & 0 & -2 \\ 2 & 1 & 5 \\ -1 & 3 & 0 \end{bmatrix}$  is a matrix of order 3.

e.g.  $\begin{bmatrix} 2 & 3 & 4 \\ 1 & -8 & 5 \end{bmatrix}$  is a  $2 \times 3$  matrix.

e.g.  $\begin{bmatrix} 2 \\ 7 \\ -3 \end{bmatrix}$  is a  $3 \times 1$  matrix.

## Elements of matrix

The element of a matrix is each number or letter in the matrix. Each element is locating by stating its position in the row and the column.

For example, given the  $3 \times 4$  matrix  $\begin{bmatrix} 2 & 0 & 3 & 6 \\ 3 & 4 & 7 & 0 \\ 1 & 9 & 2 & 5 \end{bmatrix}$

- The element 1 is in the third row and first column.
- The element 6 is in the first row and fourth column.

Note;

A matrix in which the number of rows is equal to the number of columns is called a square matrix.

$$\begin{bmatrix} 1 & 0 & -2 \\ 2 & 1 & 5 \\ -1 & 3 & 0 \end{bmatrix}$$

$[a_1 \ a_2 \ \dots \ a_n]$  Is called a *row matrix* or *row vector*.

$\begin{bmatrix} b_1 \\ b_2 \\ \vdots \\ b_n \end{bmatrix}$  Is called a *column matrix* or *column vector*.

$\begin{bmatrix} 2 \\ 7 \\ -3 \end{bmatrix}$  Is a column vector of order  $3 \times 1$ .

$[-2 \ -3 \ -4]$  is a row vector of order  $1 \times 3$ .

Two or more matrices are equal if they are of the same order and their corresponding elements are equal.

Thus, if  $\begin{bmatrix} a & c \\ c & d \end{bmatrix} = \begin{bmatrix} 3 & 4 \\ 1 & 5 \end{bmatrix}$  then,  $a = 3$ ,  $b = 4$  and  $d = 5$ .

Addition and subtraction of matrices

Matrices can be added or subtracted if they are of the same order. The sum of two or more matrices is

obtained by adding corresponding elements. Subtraction is also done in the same way.

Example

$$\text{if } A = \begin{bmatrix} 2 & 5 \\ 0 & 7 \end{bmatrix} \text{ and } B = \begin{bmatrix} 1 & 3 \\ 6 & 2 \end{bmatrix} \text{ find :}$$

1.)  $A + B$

2.)  $A - B$

Solution

$$1.) A+B = \begin{bmatrix} 2 & 5 \\ 0 & 7 \end{bmatrix} + \begin{bmatrix} 1 & 3 \\ 6 & 2 \end{bmatrix} = \begin{bmatrix} 2+1 & 5+3 \\ 0+6 & 7+2 \end{bmatrix} = \begin{bmatrix} 3 & 8 \\ 6 & 9 \end{bmatrix}$$

$$2.) A - B = \begin{bmatrix} 2 & 5 \\ 0 & 7 \end{bmatrix} - \begin{bmatrix} 1 & 3 \\ 6 & 2 \end{bmatrix} = \begin{bmatrix} 2-1 & 5-3 \\ 0-6 & 7-2 \end{bmatrix} = \begin{bmatrix} 1 & 2 \\ -6 & 5 \end{bmatrix}$$

Example

$$\begin{bmatrix} 3 & 2 & 1 \\ 0 & 4 & 5 \\ 1 & 3 & 2 \end{bmatrix} - \begin{bmatrix} 2 & 4 & 1 \\ 1 & 2 & 0 \\ 5 & 9 & 6 \end{bmatrix} + \begin{bmatrix} 8 & 0 & 2 \\ 1 & 3 & 5 \\ 2 & 1 & 6 \end{bmatrix} = \begin{bmatrix} 3-2+8 & 2-4+0 & 1-1+2 \\ 0-1+1 & 4-2+3 & 5-0+5 \\ 1-5+2 & 3-9+1 & 2-6+6 \end{bmatrix}$$

$$= \begin{bmatrix} 9 & -2 & 2 \\ 0 & 5 & 10 \\ -2 & -5 & 2 \end{bmatrix}$$

Note;

After arranging the matrices you must use BODMAS

$$\begin{bmatrix} 2 & 7 \\ 4 & 9 \end{bmatrix} + \begin{bmatrix} 1 \\ 5 \\ 6 \end{bmatrix}$$

The matrix above cannot be added because they are not of the same order  $\begin{bmatrix} 2 & 7 \\ 4 & 9 \end{bmatrix}$  is of order 2 x 2 while  $\begin{bmatrix} 1 \\ 5 \\ 6 \end{bmatrix}$  is of order 3 x 1

## Matrix multiplication

To multiply a matrix by a number, you multiply each element in the matrix by the number.

Example

$$3 \begin{bmatrix} -2 & 0 \\ 4 & -7 \end{bmatrix}$$

solution

$$= \begin{bmatrix} -2(3) & 0(3) \\ 4(3) & -7(3) \end{bmatrix} = \begin{bmatrix} -6 & 0 \\ 12 & -21 \end{bmatrix}$$

**Example**

$$-2 \begin{bmatrix} 1 & -2 \\ 0 & 3 \\ -4 & 5 \end{bmatrix} + \begin{bmatrix} -4 & 5 \\ 6 & -8 \\ -2 & 6 \end{bmatrix}$$

**Solution**

$$\begin{bmatrix} -2 & 4 \\ 0 & -6 \\ 8 & -10 \end{bmatrix} + \begin{bmatrix} -4 & 5 \\ 6 & -8 \\ -2 & 6 \end{bmatrix}$$

$$= \begin{bmatrix} -6 & 9 \\ 6 & -14 \\ 6 & -4 \end{bmatrix}$$

**Example**

A woman wanted to buy one sack of potatoes, three bunches of bananas and two basket of onion. She went to kikuyu market and found the prices as sh 280 for the sack of potatoes ,sh 50 for a bunch of bananas and sh 100 for a basket of onions. At kondelee market the corresponding prices were sh 300, sh 48 and sh 80.

- Express the woman's requirements as a row matrix
- Express the prices in each market as a column matrix
- Use the matrices in (a) and (b) to find the total cost in each market

**Solution**

a.) Requirements in matrix form is (1 3 2)

b.) Price matrix for Kikuyu market is  $\begin{bmatrix} 280 \\ 50 \\ 100 \end{bmatrix}$

Price matrix for kondelee market  $\begin{bmatrix} 300 \\ 48 \\ 80 \end{bmatrix}$

c.) Total cost in shillings at Kikuyu Market is;

$$(1 \ 3 \ 2) \begin{bmatrix} 280 \\ 50 \\ 100 \end{bmatrix} = (1 \times 280 + 3 \times 50 + 2 \times 100) = (630)$$

Total cost in shillings at Kondelee Market is;

$$(1 \ 3 \ 2) \begin{bmatrix} 300 \\ 48 \\ 80 \end{bmatrix} = (1 \times 300 + 3 \times 48 + 2 \times 80) = (604)$$

The two results can be combined into one as shown below

$$(1 \ 3 \ 2) \begin{bmatrix} 280 & 300 \\ 50 & 48 \\ 100 & 80 \end{bmatrix} = (630 \ 604)$$

### Note;

The product of two matrices  $A$  and  $B$  is defined provided the number of columns in  $A$  is equal to the number of rows in  $B$ .

If  $A$  is an  $m \times n$  matrix and  $B$  is an  $n \times p$  matrix, then the product  $AB$  is an  $m \times p$  matrix.

$$A \times B = AB$$

$$m \times n \quad n \times p = m \times p$$

Each time a row is multiplied by a column

### Example

Find  $AB$  if  $A = \begin{bmatrix} -2 & 3 \\ 1 & -4 \\ 6 & 0 \end{bmatrix}$  and  $B = \begin{bmatrix} -1 & 3 \\ -2 & 4 \end{bmatrix}$

### Solution

Because  $A$  is a  $3 \times 2$  matrix and  $B$  is a  $2 \times 2$  matrix, the product  $AB$  is defined and is a  $3 \times 2$  matrix. To write the elements in the first row and first column of  $AB$ , multiply corresponding elements in the first row of  $A$  and the first column of  $B$ . Then add. Use a similar procedure to write the other entries of the product.

$$\begin{aligned} AB &= \begin{bmatrix} -2 & 3 \\ 1 & -4 \\ 6 & 0 \end{bmatrix} \begin{bmatrix} -1 & 3 \\ -2 & 4 \end{bmatrix} \\ &= \begin{bmatrix} (-2)(-1) + (3)(-2) & (-2)(3) + (3)(4) \\ (1)(-1) + (-4)(-2) & (1)(3) + (-4)(4) \\ (-6)(-1) + (0)(-2) & (6)(3) + (0)(4) \end{bmatrix} \\ &= \begin{bmatrix} -4 & 6 \\ 7 & -13 \\ -6 & 18 \end{bmatrix} \end{aligned}$$

### Identity matrix

For matrices, the identity matrix or a unit matrix is the matrix that has 1's on the main diagonal and 0's elsewhere. The main diagonal is the one running from top left to bottom right. It is also called leading or principle diagonal. Examples are;

$$I = \begin{bmatrix} 1 & 0 \\ 0 & 1 \end{bmatrix}$$

2 X 2 identity matrix

$$I = \begin{bmatrix} 1 & 0 & 0 \\ 0 & 1 & 0 \\ 0 & 0 & 1 \end{bmatrix}$$

3 x 3 identity matrix

If  $A$  is any  $n \times n$  matrix and  $I$  is the  $n \times n$  identity matrix, then  $IA = A$  and  $AI = A$ .

## Determinant matrix

The determinant of a matrix is the difference of the products of the elements on the diagonals.

### Examples

The determinant of  $A$ ,  $\det A$  or  $|A|$  is defined as follows:

$$(a) \quad \text{If } n=2, \det A = \begin{vmatrix} a_{11} & b_{12} \\ b_{21} & a_{22} \end{vmatrix} = a_{11}a_{22} - b_{12}b_{21}$$

### Example

Find the determinant  $\begin{bmatrix} 1 & 3 \\ 2 & 5 \end{bmatrix}$

### Solution

Subtract the product of the diagonals

$$1 \times 5 - 2 \times 3 = 5 - 6 = -1$$

Determinant is -1

## Inverse of a matrix

Two matrices of order  $n \times n$  are inverse of each other if their product (in *both* orders) is the identity matrix of the same order  $n \times n$ . The inverse of  $A$  is written as  $A^{-1}$

### Example

Show that  $B = \begin{bmatrix} 3 & -1 \\ -5 & 2 \end{bmatrix} A = \begin{bmatrix} 2 & 1 \\ 5 & 3 \end{bmatrix}$

### Solution

$$\begin{aligned} AB &= \begin{bmatrix} 3 & -1 \\ -5 & 2 \end{bmatrix} \begin{bmatrix} 2 & 1 \\ 5 & 3 \end{bmatrix} \\ &= \begin{bmatrix} 2 \times 3 + 1 \times -5 & 2 \times -1 + 1 \times 3 \\ 5 \times 3 + 3 \times -5 & 5 \times -1 + 3 \times 2 \end{bmatrix} \\ &= \begin{bmatrix} 1 & 0 \\ 0 & 1 \end{bmatrix} = I \end{aligned}$$

$$\begin{aligned} BA &= \begin{bmatrix} 3 & -1 \\ -5 & 2 \end{bmatrix} \begin{bmatrix} 2 & 1 \\ 5 & 3 \end{bmatrix} \\ &= \begin{bmatrix} 1 & 0 \\ 0 & 1 \end{bmatrix} = I \end{aligned} \quad AB=BA=I. \text{ Hence, } A \text{ is the inverse of } B$$

### Note;

To get the inverse matrix

- Find the determinant of the matrix. If it is zero, then there is no inverse

- If it is non zero, then;
- Interchange the elements in the main diagonal
- Reverse the signs of the element in the other diagonals
- Divide the matrix obtained by the determinant of the given matrix

### In summary

The inverse of the matrix  $A = \begin{bmatrix} a & b \\ c & d \end{bmatrix}$  is

$$A^{-1} = \frac{1}{|A|} \begin{bmatrix} d & -b \\ -c & a \end{bmatrix} = \frac{1}{ad-cb} \begin{bmatrix} d & -b \\ -c & a \end{bmatrix} \text{ provided } ad - cb \neq 0$$

### Example

Find the inverse of  $A = \begin{bmatrix} 3 & 1 \\ 4 & 2 \end{bmatrix}$

### Solution

$$A^{-1} = \frac{1}{6-4} \begin{bmatrix} 2 & -1 \\ -4 & 3 \end{bmatrix} = \frac{1}{2} \begin{bmatrix} 2 & -1 \\ -4 & 3 \end{bmatrix} = \begin{bmatrix} 1 & -\frac{1}{2} \\ -2 & \frac{3}{2} \end{bmatrix}$$

### Check

You can check the inverse by showing that  $AA^{-1}$

$$\begin{bmatrix} 3 & 1 \\ 4 & 2 \end{bmatrix} \begin{bmatrix} 1 & -\frac{1}{2} \\ -2 & \frac{3}{2} \end{bmatrix} = \begin{bmatrix} 1 & 0 \\ 0 & 1 \end{bmatrix} \text{ And } \begin{bmatrix} 1 & -\frac{1}{2} \\ -2 & \frac{3}{2} \end{bmatrix} \begin{bmatrix} 3 & 1 \\ 4 & 2 \end{bmatrix} = \begin{bmatrix} 1 & 0 \\ 0 & 1 \end{bmatrix}$$

## Solutions of simultaneous linear equations using matrix

Using matrix method solve the following pairs of simultaneous equation

$$x + 2y = 4$$

$$3x - 5y = 1$$

### Solution

$$\begin{pmatrix} 1 & 2 \\ 3 & -5 \end{pmatrix} \begin{pmatrix} x \\ y \end{pmatrix} = \begin{pmatrix} 4 \\ 1 \end{pmatrix}$$

isabokemicah@gmail.com

$\begin{pmatrix} 1 & 2 \\ 3 & -5 \end{pmatrix}$  is the coefficients matrix of the simultaneous equations

$\begin{pmatrix} 4 \\ y \end{pmatrix}$  is the constants matrix

We need to calculate the inverse of  $A = \begin{pmatrix} 1 & 2 \\ 3 & -5 \end{pmatrix}$

$$A^{-1} = \frac{1}{(1)(-5) - (2)(3)} \begin{pmatrix} -5 & -2 \\ -3 & 1 \end{pmatrix} = -\frac{1}{11} \begin{pmatrix} -5 & -2 \\ -3 & 1 \end{pmatrix}$$

$$\begin{aligned} \text{Hence } A^{-1}B &= -\frac{1}{11} \begin{pmatrix} -5 & -2 \\ -3 & 1 \end{pmatrix} \begin{pmatrix} 4 \\ 1 \end{pmatrix} \\ &= -\frac{1}{11} \begin{pmatrix} -22 \\ 11 \end{pmatrix} \\ &= \begin{pmatrix} 2 \\ 1 \end{pmatrix} \end{aligned}$$

Hence the value of  $x = 2$  and the value of  $y = 1$  is the solution of the simultaneous equation

End of topic

Did you understand everything?

If not ask a teacher, friends or anybody and make sure you understand before going to sleep!

## Past KCSE Questions on the topic

- A and B are two matrices. If  $A = \begin{pmatrix} 1 & 2 \\ 4 & 3 \end{pmatrix}$  find B given that  $A^2 = A + B$
- Given that  $A = \begin{pmatrix} 1 & 3 \\ 5 & 3 \end{pmatrix}$ ,  $B = \begin{pmatrix} 3 & 1 \\ 5 & -1 \end{pmatrix}$ ,  $C = \begin{pmatrix} p & 0 \\ 0 & q \end{pmatrix}$  and  $AB = BC$ , determine the value of P
- A matrix A is given by  $A = x \begin{pmatrix} 0 & \\ 5 & y \end{pmatrix}$ 
  - Determine  $A^2$



b) If  $A^2 = \begin{pmatrix} 1 & 0 \\ 0 & 0 \end{pmatrix}$ , determine the possible pairs of values of x and y

4. (a) Find the inverse<sup>1</sup> of the matrix  $\begin{pmatrix} 9 & 8 \\ 7 & 6 \end{pmatrix}$

(b) In a certain week a businessman bought 36 bicycles and 32 radios for total of Kshs 227 280. In the following week, he bought 28 bicycles and 24 radios for a total of Kshs 174 960. Using matrix method, find the price of each bicycle and each radio that he bought

(c) In the third week, the price of each bicycle was reduced by 10% while the price of each radio was raised by 10%. The businessman bought as many bicycles and as many radios as he had bought in the first two weeks.

Find by matrix method, the total cost of the bicycles and radios that the businessman bought in the third week.

5. Determine the inverse  $T^{-1}$  of the matrix  $\begin{pmatrix} 1 & 2 \\ 1 & -1 \end{pmatrix}$

Hence find the coordinates to the point at which the two lines  $x + 2y=7$  and  $x-y=1$

6. Given that  $A = \begin{pmatrix} 0 & -1 \\ 3 & 2 \end{pmatrix}$  and  $B = \begin{pmatrix} -1 & 0 \\ 2 & -4 \end{pmatrix}$

Find the value of x if

(i)  $A - 2x = 2B$

(ii)  $3x - 2A = 3B$

(iii)  $2A - 3B = 2x$

7. Find the non- zero value of k for which  $k \begin{pmatrix} 1 & 2 \\ 4k & 2k \end{pmatrix}$  is an inverse.

8. A clothes dealer sold 3 shirts and 2 trousers for Kshs. 840 and 4 shirts and 5 trousers for Kshs 1680. Form a matrix equation to represent the above information. Hence find the cost of 1 shirt and the cost of 1 trouser.

## CHAPTER FOURTY NINE

### FORMULAE AND VARIATION

## Specific Objectives

By the end of the topic the learner should be able to:

- a) Rewrite a given formula by changing its subject
- b) Define direct, inverse, partial and joint variations
- c) Determine constants of proportionality
- d) Form and solve equations involving variations
- e) Draw graphs to illustrate direct and inverse proportions
- f) Use variations to solve real life problems

## Content

- a.) Change of the subject of a formula
- b.) Direct, inverse, partial and joint variation
- c.) Constants of proportionality
- d.) Equations involving variations
- e.) Graphs of direct and inverse proportion
- f.) Formation of equations on variations based on real life situations

## Formulae

A Formula is an expression or equation that expresses the relationship between certain quantities.

For Example  $A = \pi r^2$  is the formula to find the area of a circle of radius  $r$  units.

From this formula, we can know the relationship between the radius and the area of a circle. The area of a circle varies directly as the square of its radius. Here  $\pi$  is the constant of variation.

## Changing the subject of a formulae

### Terminology

In the formula

$$C = \pi d$$

**Subject:**  $C$

**Rule:** multiply  $\pi$  by *diameter*

The variable on the left, is known as the **subject**: What you are trying to find.

The formula on the right, is the **rule**, that tells you how to calculate the subject.

So, if you want to have a formula or rule that lets you calculate  $d$ , you need to make  $d$ , the **subject** of the formula.

This is changing the subject of the formula from  $C$  to  $d$ .

So clearly in the case above where

$$C = \pi d$$

We get  $C$  by multiplying  $\pi$  by *the diameter*

To calculate  $d$ , we need to divide the Circumference  $C$  by  $\pi$

So  $d = \frac{C}{\pi}$  and now we have  $d$  as the subject of the formula.

### Method:

A formula is simply an equation, that you cannot solve, until you replace the letters with their values (numbers). It is known as a **literal** equation.

To change the subject, apply the same rules as we have applied to normal equations.

1. Add the same variable to both sides.
2. Subtract the same variable from both sides.
3. Multiply both sides by the same variable.
4. Divide both sides by the same variable.
5. Square both sides
6. Square root both sides.

### Examples:

Make the **letter** in **brackets** the subject of the formula

$$x + p = q [ x ]$$

(subtract  $p$  from both sides)

$$x = q - p$$

$$y - r = s [ y ]$$

(add  $r$  to both sides)

$$y = s + r$$

$$P = RS [ R ]$$

(divide both sides by  $S$ )

$$S = \frac{P}{R}$$

$$\frac{A}{B} = L \quad [A]$$

(multiply both sides by B)

$$A = LB$$

$$2w + 3 = y \quad [w]$$

(subtract 3 from both sides)

$$2w = y - 3$$

(divide both sides by 2)

$$w = \frac{y-3}{2}$$

$$P = \frac{1}{3}Q \quad [Q]$$

(multiply both sides by 3- get rid of fraction)

$$3P = Q$$

$$T = \frac{2}{5}k \quad [k]$$

(multiply both sides by 5- get rid of fraction)

$$5T = 2k$$

(divide both sides by 2)

$$\frac{5T}{2} = k \quad \text{Note that: } \frac{5T}{2} \text{ is the same as } \frac{5}{2}T$$

$$A = \pi r^2 r \quad [r]$$

(divide both sides by p)

$$\frac{A}{\pi} = r^2 \quad (\text{square root both sides}) \quad \sqrt{\frac{A}{\pi}} = r$$

$$L = \frac{1}{2}h - t \quad [h]$$

(multiply both sides by 2)

$$2L = h - t$$

(add t to both sides)

$$2L + t = h$$

**Example**

Make d the subject of the formula  $G = \sqrt{\frac{d-x}{d-1}}$

**Solution**

Squaring both sides

$$G^2 = \frac{d-x}{d-1}$$

Multiply both sides by d-1

isabokemicah@gmail.com

$$G^2(d-1) = d - x$$

Expanding the L.H.S

$$d G^2 - G^2 = d - x$$

Collecting the terms containing  $d$  on the L.H.S

$$d G^2 - d = G^2 - x$$

Factorizing the L.H.S

$$d (G^2 - 1) = G^2 - x$$

Dividing both sides by

$$d = \frac{(G^2 - 1)(G^2 - x)}{G^2 - 1}$$

## Variation

In a formula some elements which do not change (fixed) under any condition are called constants while the ones that change are called variables. There are different types of variations.

- **Direct Variation**, where both variables either increase or decrease together
- **Inverse or Indirect Variation**, where when one of the variables increases, the other one decreases
- **Joint Variation**, where more than two variables are related directly
- **Combined Variation**, which involves a combination of direct or joint variation, **and** indirect variation

### Examples

- **Direct:** The number of money I make varies directly (or you can say **varies proportionally**) with how much I work.
- **Direct:** The length of the side a square varies directly with the perimeter of the square.
- **Inverse:** The number of people I invite to my bowling party varies inversely with the number of games they might get to play (or you can say **is proportional to the inverse of**).
- **Inverse:** The temperature in my house varies indirectly (same as inversely) with the amount of time the air conditioning is running.
- **Inverse:** My school marks may vary inversely with the number of hours I watch TV.

## Direct or Proportional Variation

When two variables are related directly, the ratio of their values is always the same. So as one goes up, so does the other, and if one goes down, so does the other. Think of linear direct variation as a " **$y = mx$** " line, where the ratio of  **$y$**  to  **$x$**  is the **slope** ( $m$ ). With direct variation, the  **$y$** -intercept is always 0 (zero); this is how it's defined.

Direct variation problems are typically written:

→  $y = kx$  where  **$k$**  is the ratio of  **$y$**  to  **$x$**  (which is the same as the **slope** or **rate**).

Some problems will ask for that  **$k$**  value (which is called the **constant of variation** or **constant of proportionality**); others will just give you 3 out of the 4 values for  **$x$**  and  **$y$**  and you can simply set up a ratio to find the other value.

Remember the example of making ksh 1000 per week ( $y = 10x$ )? This is an example of **direct variation**, since the ratio of how much you make to how many hours you work is always constant.

## Direct Variation Word Problem:

The amount of money raised at a school fundraiser is directly proportional to the number of people who attend. Last year, the amount of money raised for 100 attendees was \$2500. **How much money will be raised if 1000 people attend this year?**

**Solution:**

Let's do this problem using both the **Formula Method** and the **Proportion Method**:

Formula method

Explanation

$y = kx$ $2500 = k100$ $k = 25$	Since the amount of money is <b>directly proportional</b> (varies directly) to the number who attend, we know that $y = kx$ , where $y$ = the amount of money raised and $x$ = the number of attendees. (Since the problem states that the amount of money is directly proportional to the number of attendees, we put the amount of money first, or as the $y$ ).
$y = 25x$ $y = 25(1000)$ $y = 25000$	We need to fill in the numbers from the problem, and solve for $k$ . We see that $k = 25$ . So we have $y = 25x$ . We plug the new $x$ , which is 1000
	We get the new $y = 25000$ . So if 1000 people attend, \$25,000 would be raised!

Proportional method

Explanation

$\frac{\$2500}{100 \text{ attendees}} = \frac{\$y}{1000 \text{ attendees}}$	We can set up a proportion with the $y$ 's on top (amount of money), and the $x$ 's on bottom (number of attendees).
$100y = 2500000$	We can then cross multiply to get the new amount of money ( $y$ ).
$y = 25000$	We get the new $y = 25000$ . So if 1000 people attend, \$25,000 will be raised!

## Direct Square Variation Word Problem

Again, a **Direct Square Variation** is when  $y$  is proportional to the square of  $x$ , or  $y = kx^2$ .

Example

If  $y$  varies directly with the square of  $x$ , and if  $y = 4$  when  $x = 3$ , what is  $y$  when  $x = 2$ ?

**Solution:**

Let's do this with the formula method and the proportion method:

### Formulae method

$$y = kx^2 \quad y = \frac{4}{9}x^2$$

$$4 = k3^2 \quad y = \frac{4}{9}(2)^2$$

$$k = \frac{4}{9} \quad y = \frac{16}{9}$$

### notes

Since  $y$  is **directly proportional** (varies directly) to the square of  $x$ , we know that  $y = kx^2$ . Plug in the first numbers we have for  $x$  and  $y$  to see that  $k = \frac{16}{9}$ .  
So we have  $y = \frac{4}{9}x^2$ . We plug the new  $x$ , which is 2, and get the new  $y$ , which is  $\frac{16}{9}$ .

### Proportional method

### Notes

$$\frac{y_1}{(x_1)^2} = \frac{y_2}{(x_2)^2}$$

$$\frac{4}{3^2} = \frac{y}{2^2}$$

$$y = \frac{4 \cdot 2^2}{3^2} = \frac{16}{9}$$

We can set up a proportion with the  $y$ 's on top, and  $x^2$  on the bottom.

We can plug in the numbers we have, and then cross multiply to get the new  $y$ .

We then get the new  $y = \frac{16}{9}$ .

### Example

The length ( $l$ ) cm of a wire varies directly as the temperature  $T$ °c. The length of the wire is 5 cm when the temperature is 65°c. Calculate the length of the wire when the temperature is 69°c.

### Solution

$$l \propto T$$

$$\text{Therefore } l = Kt$$

Substituting  $l = 5$  when  $T = 65$ °c.

$$5 = k \times 65$$

$$K = \frac{5}{65} = \frac{1}{13}$$

$$\text{Therefore } l = \frac{1}{13} T$$

When  $t = 69$

$$L = \frac{1}{13} \times 69 = 5 \frac{4}{13} \text{ cm}$$

## Direct variation graph

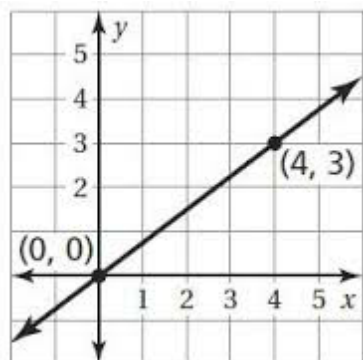

## Inverse or Indirect Variation

**Inverse** or **Indirect** Variation refers to relationships of two variables that go in the opposite direction. Let's suppose you are comparing how fast you are driving (average speed) to how fast you get to your work. The faster you drive the earlier you get to your work. So as the speed increases time reduces and vice versa.

So the formula for inverse or indirect variation is:

$$\rightarrow y = \frac{k}{x} \quad \text{or } k = xy \quad \text{where } k \text{ is always the same number or constant.}$$

(Note that you could also have an **Indirect Square Variation** or **Inverse Square Variation**, like we saw above for a Direct Variation. This would be of the form  $\rightarrow y = \frac{k}{x^2}$  or  $k = x^2y$ .)

### Inverse Variation Word Problem:

So we might have a problem like this:

The value of **y varies inversely** with **x**, and **y = 4** when **x = 3**. **Find x**



isabokemicah@gmail.com

$$y = \frac{k}{x} \text{ or } xy = k$$

$$x_1y_1 = x_2y_2$$

In our case,  $k = 250$ :

$$xy = 250 \text{ or } y = \frac{250}{x}$$

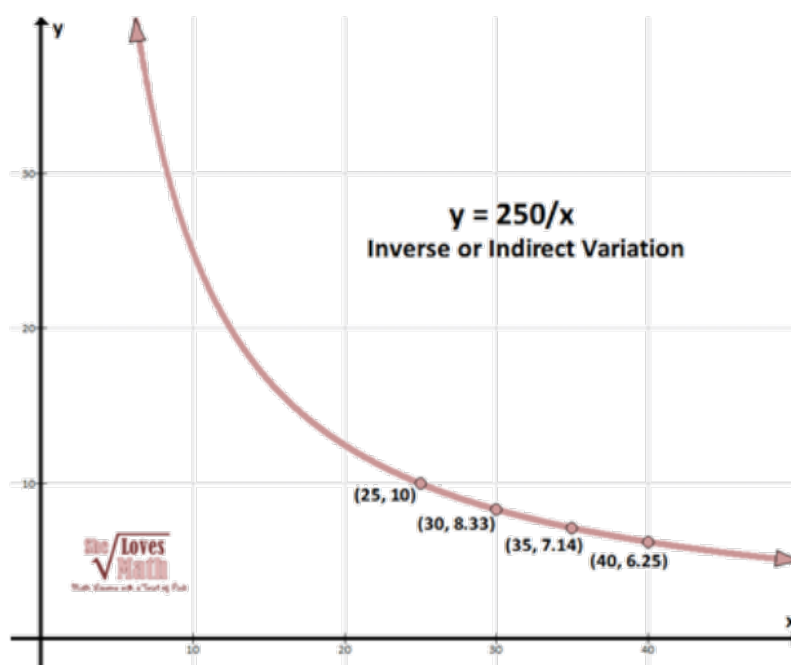

when  $y = 6$ .

The problem can also be written as follows:

Let  $x_1 = 3$ ,  $y_1 = 4$ , and  $y_2 = 6$ . Let  $y$  vary inversely as  $x$ . Find  $x_2$ .

**Solution:**

We can solve this problem in one of two ways, as shown. We do these methods when we are given any three of the four values for  $x$  and  $y$ .

$y_1 = \frac{k}{x_1}$ $4 = \frac{k}{3}$ $k = 12$ $y_2 = \frac{12}{x_2}$ $6 = \frac{12}{x_2}$ $6x_2 = 12; x_2 = 2$	<p>Since <math>x</math> and <math>y</math> vary inversely, we know that <math>xy = k</math>, or <math>y = \frac{k}{x}</math>.</p> <p>We first fill in the <math>x</math> and <math>y</math> values with <math>x_1</math> and <math>y_1</math>, from the problem. Remember that the variables with the same subscript (<math>x_1, y_1</math>) stay together. We then solve for <math>k</math>, which is 12.</p> <p>We then put the <math>y_2</math> value in for <math>y</math> (if the <math>x_2</math> value were given, you'd put that in for <math>x</math>, and solve for <math>y_2</math>). We then solve for <math>x_2</math>, which is 2.</p> <p>The formula way may take a little more time, but you may be asked to do it this way, especially if you need to find <math>k</math>, and the equation of variation, which is <math>y = \frac{12}{x}</math>.</p>
--	--

## Product Rule Method:

$$x_1 y_1 = x_2 y_2$$

$$(3)(4) = x_2(6)$$

$$12 = 6x_2$$

$$x_2 = 2$$

We know that when you multiply the  $x$ 's and  $y$ 's (with the **same subscript**) we get a constant, which is  $k$ . You can see that  $k = 12$  in this problem.

So we can just substitute in all the numbers that we are given and solve for the number we want – in this case,  $x_2$ .

This way is easier than the formula method, but, again, you will probably be asked to know both ways.

## Inverse Variation Word Problem:

For the club, the number of tickets Moyo can buy is **inversely proportional** to the price of the tickets. She can afford 15 tickets that cost \$5 each. **How many tickets can she buy if each cost \$3?**

**Solution:**

Let's use the product method:

$$x_1 y_1 = x_2 y_2$$

$$(5)(15) = x_2(3)$$

$$75 = 3x_2$$

$$x_2 = 25$$

We know that when you multiply the  $x$ 's and  $y$ 's we get a constant, which is  $k$ . So the number of tickets Allie can buy times the price of each ticket is  $k$ . We can let the  $x$ 's be the price of the tickets.

So we can just substitute in all the numbers that we are given and solve for the number we want. So we see that Allie can buy **25 tickets** that cost \$3. This makes sense, since we can see that she only can spend \$75 (which is  $k$ !)

## Example

If 16 women working 7 hours a day can paint a mural in 48 days, how many days will it take 14 women working 12 hours a day to paint the same mural?

**Solution:**

The three different values are inversely proportional; for example, the more women you have, the less days it takes to paint the mural, and the more hours in a day the women paint, the less days they need to complete the mural:

$$x_1 y_1 z_1 = x_2 y_2 z_2$$

$$(16)(7)(48) = (14)(12)z_2$$

$$5376 = 168z_2$$

$$z_2 = 32$$

Since each woman is working at the same rate, we know that when we multiply the **number of women** ( $x$ ) by the **number of the hours a day** ( $y$ ) by the **number of days they work** ( $z$ ), it should always be the same (a constant). (Try it yourself with some easy numbers).

So we can just substitute in all the numbers that we are given and solve for the number we want (days). So we see that it would take **32 days** for 14 women that work 12 hours a day to paint the mural. In this case, our  $k$  is 5376, which represents the number of hours it would take **one woman alone to paint the mural**.

## Joint Variation and Combined Variation

**Joint variation** is just like direct variation, but involves more than one other variable. All the variables are directly proportional, taken one at a time. Let's do a joint variation problem:

Supposed  $x$  varies jointly with  $y$  and the square root of  $z$ . When  $x = -18$  and  $y = 2$ , then  $z = 9$ . **Find  $y$  when  $x = 10$  and  $z = 4$ .**

$$\begin{aligned} x &= ky\sqrt{z} \\ -18 &= k(2)\sqrt{9} \\ -18 &= 6k \\ k &= -3 \end{aligned}$$

$$\begin{aligned} x &= ky\sqrt{z}; \quad x = -3y\sqrt{z} \\ 10 &= -3y\sqrt{4}; \quad 10 = -3y(2) \\ y &= \frac{10}{-6} = -\frac{5}{3} \end{aligned}$$

Again, we can set it up almost word for word from the word problem. For the words "varies jointly", just basically use the "=" sign, and everything else will fall in place.

Solve for  $k$  first by plugging in variables we are given at first; we get  $k = -3$ .

Now we can plug in the new values of  $x$  and  $z$  to get the new  $y$ .

So  $y$  will be  $-\frac{5}{3}$ . Really not that bad!

**Combined variation** involves a combination of direct or joint variation, and indirect variation. Since these equations are a little more complicated, you probably want to plug in all the variables, solve for  $k$ , and then solve back to get what's missing. Here is the type of problem you may get:

(a)  $y$  varies jointly as  $x$  and  $w$  and **inversely** as the square of  $z$ . **Find the equation of variation when  $y = 100$ ,  $x = 2$ ,  $w = 4$ , and  $z = 20$ .**

(b) **Then solve for  $y$  when  $x = 1$ ,  $w = 5$ , and  $z = 4$ .**

**Solution:**

$$\begin{aligned} y &= \frac{kxw}{z^2} \\ 100 &= \frac{k(2)(4)}{(20)^2} = \frac{8k}{400} \\ 8k &= 100(400) \\ k &= \frac{(100)(400)}{8} = 5000 \\ y &= \frac{5000xw}{z^2} \quad (\text{answer to a}) \end{aligned}$$

$$\begin{aligned} y &= \frac{5000(1)(5)}{4^2} \\ y &= \frac{25000}{16} = \mathbf{1562.5} \quad (\text{answer to b}) \end{aligned}$$

Now this looks really complicated, and you may get "word problems" like this, but all we do is fill in all the variables we know, and then solve for  $k$ . We know that "the square of  $z$ " is a fancy way of saying  $z^2$ .

Remember that what follows the "varies jointly as" is typically on the **top** of any fraction (this is like a direct variation), and what follows "inversely as" is typically on the **bottom** of the fraction. And always put  $k$  on the top.

Now that we have the  $k$ , we have the answer to (a) above by plugging it in the original equation.

Now we can get the new  $y$  when we have "new"  $x$ ,  $w$ , and  $z$  values.

So, for the second part of the problem, when  $x = 1$ ,  $w = 5$ , and  $z = 4$ ,  **$y = 1562.5$** . (Just plug in).

**Example**

The volume of wood in a tree ( $V$ ) **varies directly** as the height ( $h$ ) and **inversely** as the square of the girth ( $g$ ). If the volume of a tree is 144 cubic meters when the height is 20 meters and the girth is 1.5 meters, **what is the height of a tree with a volume of 1000 and girth of 2 meters?**

**Solution:**

$V = \frac{k(\text{height})}{(\text{girth})^2}$ $V = \frac{kh}{g^2}$ $144 = \frac{k(20)}{(1.5)^2} = \frac{20k}{2.25}$ $20k = 144(2.25)$ $k = \frac{(144)(2.25)}{20} = 16.2$ $V = \frac{kh}{g^2}; 1000 = \frac{16.2h}{2^2}$ $h = \frac{1000(2^2)}{16.2} = 246.91$	<p>We can set it up almost word for word from the word problem. For the words “varies directly”, just basically use the “=” sign, and everything else will fall in place.</p> <p>Remember to put everything on top for direct variation (including <math>k</math>), unless the problem says “inversely as”; those go on bottom.</p> <p>Solve for <math>k</math> first; we get <math>k = 16.2</math>.</p> <p>Now we can plug in the new values to get the new height.</p> <p>So the new height is 246.1 meters.</p>
---	--

**Example**

The average number of phone calls per day between two cities has found to be **jointly proportional** to the populations of the cities, and **inversely proportional** to the square of the distance between the two cities. The population of Charlotte is about 1,500,000 and the population of Nashville is about 1,200,000, and the distance between the two cities is about 400 miles. The average number of calls between the cities is about 200,000.

(a) **Find the  $k$  and write the equation of variation.**

(b) The average number of daily phone calls between Charlotte and Indianapolis (which has a population of about 1,700,000) is about 134,000. **Find the distance between the two cities.**

**Solution:**

It may be easier if you take it one step at a time:

Math's

Explanation

$$C = \frac{k(P_1)(P_2)}{d^2}$$

$$200000 = \frac{k(1500000)(1200000)}{400^2}$$

$$k = \frac{(200000)(400)^2}{(1500000)(1200000)} = .01778$$

$$C = \frac{.01778(P_1)(P_2)}{d^2} \leftarrow \text{answer to (a)}$$

$$134000 = \frac{.01778(1500000)(1700000)}{d^2}$$

$$134000d^2 = .01778(1500000)(1700000)$$

$$d = \mathbf{581.7 \text{ miles}} \leftarrow \text{answer to (b)}$$

We can set it up almost word for word from the word problem. Remember to put everything on top for "jointly proportional" (including k) since these are direct variations, and everything on bottom for "inversely proportional".

Solve for k first; we get k = .01778.

Now we can plug in the new values to get the distance between the cities (d). We can actually cross multiply to get d<sup>2</sup>, and then take the positive square root get d.

So the distance between Charlotte and Indianapolis is about **581.7 miles**.

In reality, the distance between these two cities is 585.6 miles, so we weren't too far off!

**Example**  
A varies directly as B and inversely as the square root of C. Find the percentage change in A when B is decreased by 10 % and

C increased by 21%.

Solution

$$A = K \frac{B}{\sqrt{C}} \dots \dots \dots (1)$$

A change in B and C causes a change in A

$$A_1 = K \frac{B_1}{\sqrt{C_1}} \dots \dots \dots (2)$$

$$B_1 = \frac{90}{100} B$$

$$= 0.9B$$

$$C_1 = \frac{121}{100} C$$

$$= 1.21C$$

Substituting B<sub>1</sub> and C<sub>1</sub> in equation (2)

$$A_1 = K \frac{0.9B}{\sqrt{1.21C}}$$

$$= \frac{0.9}{1.1} \left( K \frac{B}{\sqrt{C}} \right)$$

$$= \frac{9}{11} A$$

$$\text{Percentage change in A} = \frac{A_1 - A}{A} - 100\%$$

$$= \frac{\frac{9}{11} A - A}{A} - 100\%$$

$$= -18 \frac{2}{11} \%$$

Therefore A decreases  $18\frac{2}{11}\%$

## Partial variation

The general linear equation  $y = mx + c$ , where  $m$  and  $c$  are constants, connects two variables  $x$  and  $y$ . In such case we say that  $y$  is partly constant and partly varies as  $x$ .

### Example

A variable  $y$  is partly constant and partly varies as if  $x = 2$  when  $y = 7$  and  $x = 4$  when  $y = 11$ , find the equation connecting  $y$  and  $x$ .

### Solution

The required equation is  $y = kx + c$  where  $k$  and  $c$  are constants

Substituting  $x = 2, y = 7$  and  $x = 4, y = 11$  in the equation gives ;

$$7 = 2k + c \dots\dots\dots(1)$$

$$11 = 4k + c \dots\dots\dots(2)$$

Subtracting equation 1 from equation 2 ;

$$4 = 2k$$

Therefore  $k = 2$

Substituting  $k = 2$  in the equation 1 ;

$$C = 7 - 4$$

$$C = 3$$

Therefore the equation required is  $y = 2x + 3$

End of topic

Did you understand everything?

If not ask a teacher, friends or anybody and make sure you understand before going to sleep!

## Past KCSE Questions on the topic.

1. The volume  $V \text{ cm}^3$  of an object is given by

$$V = \frac{2}{3} \pi r^3 \left( \frac{2}{sc^2} \right)$$

Express in term of  $\pi$ ,  $r$ ,  $s$  and  $V$

2. Make  $V$  the subject of the formula

$$T = \frac{1}{2} m (u^2 - v^2)$$

3. Given that  $y = \frac{b - bx^2}{cx^2 - a}$  make  $x$  the subject

$$cx^2 - a$$

4. Given that  $\log y = \log (10^n)$  make  $n$  the subject

5. A quantity  $T$  is partly constant and partly varies as the square root of  $S$ .

- i. Using constants  $a$  and  $b$ , write down an equation connecting  $T$  and  $S$ .
- ii. If  $S = 16$ , when  $T = 24$  and  $S = 36$  when  $T = 32$ , find the values of the constants  $a$  and  $b$ ,

6. A quantity  $P$  is partly constant and partly varies inversely as a quantity  $q$ , given that  $p = 10$  when  $q = 1.5$  and  $p = 20$ , when  $q = 1.25$ , find the value of  $p$  when  $q = 0.5$

7. Make  $y$  the subject of the formula  $p = \frac{xy}{x-y}$

$$x-y$$

8. Make  $P$  the subject of the formula

$$P^2 = (P - q) (P-r)$$

9. The density of a solid spherical ball varies directly as its mass and inversely as the cube of its radius

When the mass of the ball is 500g and the radius is 5 cm, its density is 2 g per  $\text{cm}^3$

Calculate the radius of a solid spherical ball of mass 540 density of 10g per  $\text{cm}^3$

10. Make  $s$  the subject of the formula

$$\sqrt{P} = r \sqrt{1 - as^2}$$

11. The quantities  $t$ ,  $x$  and  $y$  are such that  $t$  varies directly as  $x$  and inversely as the square root of  $y$ . Find the percentage in  $t$  if  $x$  decreases by 4% when  $y$  increases by 44%

12. Given that  $y$  is inversely proportional to  $x^n$  and  $k$  as the constant of proportionality;

- (a)
  - (i) Write down a formula connecting  $y$ ,  $x$ ,  $n$  and  $k$
  - (ii) If  $x = 2$  when  $y = 12$  and  $x = 4$  when  $y = 3$ , write down two expressions for  $k$  in terms of  $n$ .

Hence, find the value of  $n$  and  $k$ .

- (b) Using the value of  $n$  obtained in (a) (ii) above, find  $y$  when  $x = 5^{1/3}$



13. The electrical resistance,  $R$  ohms of a wire of a given length is inversely proportional to the square of the diameter of the wire,  $d$  mm. If  $R = 2.0$  ohms when  $d = 3$ mm. Find the value  $R$  when  $d = 4$  mm.

14. The volume  $V$  cm<sup>3</sup> of a solid depends partly on  $r$  and partly on  $r$  where  $r$  cm is one of the dimensions of the solid.

When  $r = 1$ , the volume is  $54.6$  cm<sup>3</sup> and when  $r = 2$ , the volume is  $226.8$  cm<sup>3</sup>

(a) Find an expression for  $V$  in terms of  $r$

(b) Calculate the volume of the solid when  $r = 4$

(c) Find the value of  $r$  for which the two parts of the volume are equal

15. The mass of a certain metal rod varies jointly as its length and the square of its radius. A rod  $40$  cm long and radius  $5$  cm has a mass of  $6$  kg. Find the mass of a similar rod of length  $25$  cm and radius  $8$  cm.

16. Make  $x$  the subject of the formula

$$P = \frac{xy}{z + x}$$

17. The charge  $c$  shillings per person for a certain service is partly fixed and partly inversely proportional to the total number  $N$  of people.

(a) Write an expression for  $c$  in terms on  $N$

(b) When  $100$  people attended the charge is Kshs  $8700$  per person while for  $35$  people the charge is Kshs  $10000$  per person.

(c) If a person had paid the full amount charge is refunded. A group of people paid but ten percent of organizer remained with Kshs  $574000$ .

Find the number of people.

18. Two variables  $A$  and  $B$  are such that  $A$  varies partly as  $B$  and partly as the square root of  $B$  given that  $A=30$ , when  $B=9$  and  $A=16$  when  $B=14$ , find  $A$  when  $B=36$ .

19. Make  $p$  the subject of the formula

$$A = \frac{-EP}{\sqrt{P^2 + N}}$$



## CHAPTER FIFTY

# SEQUENCE AND SERIES

### Specific Objectives

By the end of the topic the learner should be able to:

- (a) Identify simple number patterns;
- (b) Define a sequence;
- (c) Identify the pattern for a given set of numbers and deduce the general rule;
- (d) Determine a term in a sequence;
- (e) Recognize arithmetic and geometric sequences;
- (f) Define a series;
- (g) Recognize arithmetic and geometric series (Progression);
- (h) Derive the formula for partial sum of an arithmetic and geometric series(Progression);
- (i) Apply A.P and G.P to solve problems in real life situations.

### Content

- (a) Simple number patterns
- (b) Sequences
- (c) Arithmetic sequence
- (d) Geometric sequence
- (e) Determining a term in a sequence
- (f) Arithmetic progression (A.P)
- (g) Geometric progression (G.P)
- (h) Sum of an A.P
- (i) Sum of a G.P (exclude sum to infinity)
- (j) Application of A.P and G.P to real life situations.

### Introduction

**Sequences and Series** are basically just numbers or expressions in a row that make up some sort of a **pattern**; for example, **Monday, Tuesday, Wenesday, ..., Friaday** is a sequence that represents the days of the week. Each of these numbers or expressions are called **terms** or **elements** of the sequence.

**Sequences** are the **list** of these items, separated by **commas**, and **series** are the **sum** of the terms of a sequence.

### Example

isabokemicah@gmail.com

Sequence

Next two terms

1, 8, 27, - , -

Every term is cubed .The next two terms are  $4^3 = 64$  ,  $5^3 = 125$

3, 7, 11, 15 - , - ,

every term is 4 more than the previous one. To get the next term add 4

$$15 + 4 = 19, 19 + 4 = 23$$

$\frac{1}{2}$ ,  $\frac{2}{4}$ ,  $\frac{3}{8}$ , - , -

On the numerator, the next term is 1 more than the previous one, and the

denominator, the next term is multiplied by 2 the next two terms are  $\frac{4}{16}$ ,  $\frac{5}{32}$

### Example

For the  $n^{\text{th}}$  term of a sequence is given by  $2n + 3$ , Find the first, fifth, twelfth terms

### Solution

First term,  $n = 1$  substituting  $(2 \times 1 + 3 = 5)$

Fifth term,  $n = 5$  substituting  $(2 \times 5 + 3 = 13)$

Twelfth term,  $n = 12$  substituting  $(2 \times 12 + 3 = 27)$

## Arithmetic and geometric sequence

### Arithmetic sequence.

Any sequence of a number with common difference is called arithmetic sequence

To decide whether a sequence is arithmetic, find the differences of consecutive terms. If each differences are not constant, the it is arithmetic sequence

### Rule for an arithmetic sequence

The  $n^{\text{th}}$  term of an arithmetic sequence with first term  $a_1$  and common difference  $d$  is given by:

$$a_n = a_1 + (n - 1)d$$

Example	Illustrations
---------	---------------

<p>Find the general formula for the <math>n</math>th term, and then find the 18<sup>th</sup> term (<math>a_{18}</math>) of the sequence: <math>4, 7, 10, 13, \dots</math></p>	<p>We can see that the <b>second term – the first = the third term – the second = 3</b>, so this is the <b>common difference</b>. We also see that the first term is <b>4</b>, so now we can plug these numbers into the <b>general formula</b> of the equation: <math>a_n = a_1 + (n-1)d</math>, or <math>a_n = 4 + (n-1)3 = 4 + 3n - 3 = 3n + 1</math>. So the general formula is <math>a_n = 3n + 1</math>. To get the 18<sup>th</sup> term, we'll plug in <b>18</b> for <math>n</math>, so we have <math>a_{18} = 3(18) + 1 = 55</math>.</p>
<p>Find the general formula for the <math>n</math>th term, and then find the 12<sup>th</sup> term (<math>a_{12}</math>) of the sequence: <math>8, -1, -10, -19, \dots</math></p>	<p>We can see that the <b>second term – the first = the third term – the second = <math>-1 - 8 = -9</math></b> (watch the negative signs!), so this is the <b>common difference</b>. We also see that the first term is <b>8</b>, so now we can plug these numbers into the <b>general formula</b> of the equation: <math>a_n = a_1 + (n-1)d</math>, or <math>a_n = 8 + (n-1)(-9) = 8 - 9n + 9 = -9n + 17</math>. So the general formula is <math>a_n = -9n + 17</math>. To get the 12<sup>th</sup> term, we'll plug in <b>12</b> for <math>n</math>, so we have <math>a_{12} = -9(12) + 17 = -91</math>.</p>
<p>Find the general formula for the <math>n</math>th term, and then find the 8<sup>th</sup> term (<math>a_8</math>) of the sequence: <math>r, r-s, r-2s, \dots</math></p>	<p>We can see that the <b>second term – the first = the third term – the second = <math>(r-s) - r = 0 - s = -s</math></b> (watch the negative signs!), so this is the <b>common difference</b>. We also see that the first term is <math>r</math>, so now we can plug these numbers into the <b>general formula</b> of the equation: <math>a_n = a_1 + (n-1)d</math>, or <math>a_n = r + (n-1)(-s)</math> (we can just leave it like this). To get the 8<sup>th</sup> term, we'll plug in <b>8</b> for <math>n</math>, so we have <math>a_8 = r - 7s</math>.</p>

### Example

Write a rule for the  $n$ th term of the sequence 50, 44, 38, 32, . . . . Then find  $a_{20}$ .

### Solution

The sequence is arithmetic with first term  $a_1 = 50$  and common difference  $d = 44 - 50 = -6$ . So, a rule for the  $n$ th term is:

$$\begin{aligned}
 a_n &= a_1 + (n-1)d && \text{Write general rule.} \\
 &= 50 + (n-1)(-6) && \text{Substitute for } a_1 \text{ and } d. \\
 &= 56 - 6n && \text{Simplify.} \\
 \text{The 20th term is } a_{20} &= 56 - 6(20) = -64.
 \end{aligned}$$

### Example

The 20<sup>th</sup> term of arithmetic sequence is 60 and the 16<sup>th</sup> term is 20. Find the first term and the common difference.

### Solution

$$\begin{aligned}
 a + (20-1)d &= 60 \\
 a + 19d &= 60 \dots\dots\dots (1) \\
 a + (16-1)d &= 20
 \end{aligned}$$

isabokemicah@gmail.com

$$a + (15)d = 20 \dots\dots\dots(2)$$

(1) - (2) gives  
 $4d = 40$   
 $d = 10$

but  $a + 15d = 20$

Therefore  $a + 15 \times 10 = 20$   
 $a + 150 = 20$   
 $a = -130$

Hence, the first term is - 130 and the common difference is 10.

**Example**

Find the number of terms in the sequence - 3 , 0 , 3 ...54

**Solution**

The n th term is  $a + (n - 1)d$

$a = -30, d = 3$   
 $n$  th term = 54  
 therefore  $-3 + (n - 1) \times 3 = 54$   
 $3(n - 1) = 57$

$n - 1 = 19$   
 $n = 20$

**Arithmetic series/ Arithmetic progression A.P**

The sum of the terms of a sequence is called a series. If the terms of sequence are 1, 2, 3, 4, 5, when written with addition sign we get arithmetic series

$1 + 2 + 3 + 4 + 5$

The general formulae for finding the sum of the terms is

$$s_n = \frac{n}{2}[2a + (n-1)d]$$

**Note;**

If th first term (a) and the last term l are given , then

$$s_n = \frac{n}{2}[a+l]$$

**Example**

The sum of the first eight terms of an arithmetic Progression is 220.If the third term is 17, find the sum of the first six terms

**Solution**

$$s_8 = \frac{8}{2}[2a + (8-1)d]$$

$$= 4(2a + 7d)$$

So ,  $8a + 28d = 220$ .....1

The third term is  $a + (3 - 1)d = a + 2d = 17$  .....2

Solving 1 and 2 simultaneously;

$8a + 28d = 220$  .....1

$8a + 16d = 136$  .....2

$12d = 84$

$d = 7$

Substituting  $d = 7$  in equation 2 gives  $a = 3$

Therefore,

$$s_6 = \frac{6}{2}[2a + (6-1)d]$$

$= 3(6 \times 35)$

$= 3 \times 41$

$= 123$

### Geometric sequence

It is a sequence with a common ratio. The ratio of any term to the previous term must be constant.

Rule for Geometric sequence is;

The  $n$ th term of a geometric sequence with first term  $a_1$  and common ratio  $r$  is given by:

$$a_n = a_1 r^{n-1}$$

### Example

Given the geometric sequence 4 , 12 ,36 .....find the 4<sup>th</sup> , 5<sup>th</sup> and the  $n$  th terms

### Solution

The first term ,  $a = 4$

The common ratio ,  $r = 3$

Therefore the 4<sup>th</sup> term =  $4 \times 3^{4-1}$

$= 4 \times 3^3$

$= 108$

The 5<sup>th</sup> term =  $5 \times 3^{4-1}$

$= 5 \times 3^3$

$= 324$

The  $n^{\text{th}}$  term  $= 4 \times 3^{n-1}$

### Example

The 4<sup>th</sup> term of geometric sequence is 16 . If the first term is 2 , find;

- The common ration
- The seventh term

### Solution

The common ratio

The first term,  $a = 2$

The 4<sup>th</sup> term is  $2 \times r^{4-1} = 16$

Thus,  $2r^3 = 16$

$$r^3 = 8 \quad (\text{divided both sides by } 2)$$

$$r = 2 \quad (\text{make } r \text{ the subjet by dividing both sides by } 2)$$

The common ratio is 2

The seventh term  $= ar^6 = 2 \times 2^6 = 128$

## Geometric series

The series obtained by the adding the terms of geometric sequence is called geometric series or geometric progression G.P

The sum  $S_n$  of the first  $n$  terms of a geometric series with common ratio  $r > 1$  is:

$$S_n = \frac{a(r^n - 1)}{r - 1}$$

The sum  $S_n$  of the first  $n$  terms of a geometric series with common ratio  $r < 1$  is:

$$S_n = \frac{a(1 - r^n)}{1 - r}$$

### Example

Find the sum of the first 9 terms of G.P.  $8 + 24 + 72 + \dots$

### Solution

isabokemicah@gmail.com

$$a = 8, r = \frac{24}{8} = 3$$

$$S_n = \frac{a(3^n - 1)}{3 - 1}$$

$$= \frac{8(19683 - 1)}{2}$$

$$= 78728$$

### Example

The sum of the first three terms of a geometric series is 26. If the common ratio is 3, find the sum of the first six terms.

### Solution

$$s_3 = 26, r = 3, n = 3$$

$$26 = \frac{a(3^3 - 1)}{3 - 1}$$

$$= \frac{a(27 - 1)}{2}$$

$$a = \frac{26 \times 2}{26} = 2$$

$$S_6 = \frac{2(3^6 - 1)}{2}$$

$$= \frac{(2 \times 728)}{2} = 728$$

End of topic

Did you understand everything?

If not ask a teacher, friends or anybody and make sure you understand before going to sleep!

## Past KCSE Questions on the topic.

1. The first, the third and the seventh terms of an increasing arithmetic progression are three consecutive terms of a geometric progression. In the first term of the arithmetic progression is 10 find the common difference of the arithmetic progression?
2. Kubai saved Ksh 2,000 during the first year of employment. In each subsequent year, he saved 15% more than the preceding year until he retired.
  - (a) How much did he save in the second year?
  - (b) How much did he save in the third year?
  - (c) Find the common ratio between the savings in two consecutive years
  - (a) How many years did he take to save the savings a sum of Ksh 58,000?
  - (e) How much had he saved after 20 years of service?
3. In geometric progression, the first term is  $a$  and the common ratio is  $r$ . The sum of the first two terms is 12 and the third term is 16.
  - (a) Determine the ratio  $\frac{ar^2}{a + ar}$
  - (b) If the first term is larger than the second term, find the value of  $r$ .
4. (a) The first term of an arithmetic progression is 4 and the last term is 20. The Sum of the term is 252. Calculate the number of terms and the common differences of the arithmetic progression
  - (b) An Experimental culture has an initial population of 50 bacteria. The population increased by 80% every 20 minutes. Determine the time it will take to have a population of 1.2 million bacteria.
5. Each month, for 40 months, Amina deposited some money in a saving scheme. In the first month she deposited Kshs 500. Thereafter she increased her deposits by Kshs. 50 every month. Calculate the:
  - a) Last amount deposited by Amina
  - b) Total amount Amina had saved in the 40 months.
6. A carpenter wishes to make a ladder with 15 cross- pieces. The cross- pieces are to diminish uniformly in length from 67 cm at the bottom to 32 cm at the top. Calculate the length in cm, of the seventh cross- piece from the bottom
7. The second and fifth terms of a geometric progression are 16 and 2 respectively. Determine the common ratio and the first term.
8. The eleventh term of an arithmetic progression is four times its second term. The sum of the first seven terms of the same progression is 175



isabokemicah@gmail.com

- (a) Find the first term and common difference of the progression
- (b) Given that  $p^{\text{th}}$  term of the progression is greater than 124, find the least value of P

9. The  $n^{\text{th}}$  term of sequence is given by  $2n + 3$  of the sequence

- (a) Write down the first four terms of the sequence
- (b) Find  $s_n$  the sum of the fifty term of the sequence
- (c) Show that the sum of the first n terms of the sequence is given by

$$S_n = n^2 + 4n$$

Hence or otherwise find the largest integral value of n such that  $S_n < 725$

## CHAPTER FIFTY ONE

# BINOMIAL EXPANSION

### Specific Objectives

By the end of the topic the learner should be able to:

- Expand binomial expressions up to the power of four by multiplication;
- Building up - Pascal's Triangle up to the eleventh row;
- Use Pascal's triangle to determine the coefficient of terms in a binomial expansions up to the power of 10;
- Apply binomial expansion in numerical cases.

### Content

- Binomial expansion up to power four
- Pascal's triangle
- Coefficient of terms in binomial expansion
- Computation using binomial expansion
- Evaluation of numerical cases using binomial expansion.

A binomial is an expression of two terms

### Examples

$(a + y)$ ,  $a + 3$ ,  $2a + b$

It is easy to expand expressions with lower power but when the power becomes larger, the expansion or multiplication becomes tedious. We therefore use Pascal triangle to expand the expression without multiplication.

We can use Pascal triangle to obtain coefficients of expansions of the form  $(a + b)^n$

## Pascal triangle

$$\begin{array}{ccccccc}
 1 & & & & & & (a + b)^0 = 1 \\
 & 1 & & 1 & & & (a + b)^1 = 1a + 1b \\
 & & 1 & 2 & 1 & & (a + b)^2 = 1a^2 + 2ab + b^2 \\
 1 & 3 & 3 & 1 & & & (a + b)^3 = 1a^3 + 3a^2b + 3ab^2 + 1b^3 \\
 1 & 4 & 6 & 4 & 1 & & (a + b)^4 = 1a^4 + 4a^3b + 6a^2b^2 + 4ab^3 + 1b^4
 \end{array}$$

### Note;

- Each row starts with 1
- Each of the numbers in the next row is obtained by adding the two numbers on either side of it in the preceding row
- The power of first term (a) decreases as you move to right while the powers of the second term (b) increases as you move to the right

### Example

Expand  $(p + q)^5$

### Solution

The terms without coefficients are;

$$p^5, p^4q, p^3q^2, p^2q^3, pq^4, q^5$$

From Pascal triangle, the coefficients when  $n = 5$  are; 1 5 10 10 5 1

Therefore  $(p + q)^5 =$

$$p^5 + 5p^4q + 10p^3q^2 + 10p^2q^3 + 5pq^4 + q^5$$

### Example

Expand  $(x - y)^7$

### Solution

$$(x - y)^7 = (x - (-y))^7$$

The terms without the coefficient are;

$$x^7, x^6(-y), x^5(-y)^2, x^4(-y)^3, x^3(-y)^4, x^2(-y)^5, x(-y)^6, y^7$$

From Pascal triangle, the coefficients when  $n = 7$  are;

1 7 21 35 35 21 7 1

Therefore  $(x - y)^7 =$

$$x^7 - 7x^6y + 21x^5y^2 - 35x^4y^3 + 35x^3y^4 - 21x^2y^5 + 7xy^6 - y^7$$

**Note;**

When dealing with negative signs, the signs alternate with the positive sign but first start with the negative sign.

**Applications to Numeric cases**

Use binomial expansion to evaluate  $(1.02)^6$  to 4 S.F

**Solution**

$$(1.02) = (1+0.02)$$

$$\text{Therefore } (1.02)^6 = (1+ 0.02)^6$$

The terms without coefficients are

$$1^6 1^5(0.02)^1 1^4(0.02)^2 1^3(0.02)^3 \quad 1^2(0.02)^4 \quad 1^1(0.02)^5 \quad (0.02)^7$$

From Pascal triangle, the coefficients when n =6 are;

$$1 \quad 6 \quad 15 \quad 20 \quad 15 \quad 6 \quad 1$$

**Therefore;**

$$(1.02)^6 =$$

$$1 + 6 (0.02) + 15 (0.02)^2 + 20(0.02)^3 + 15(0.02)^4 + 6(0.02)^5 + (0.02)^6$$

$$=1 + 0.12 + 0.0060 + 0.00016 + 0.0000024 + 0.0000000192 + 0.000000000064$$

$$=1.1261624$$

$$=1.126 \text{ (4 S.F)}$$

**Note;**

To get the answer just consider addition of up to the 4<sup>th</sup> term of the expansion. The other terms are too small to affect the answer.

**Example**

Expand  $(1 + x)^9$  up to the term  $x^3$ . Use the expansion to estimate  $(0.98)^9$  correct to 3 decimal places.

**Solution**

$$(1 + x)^9$$

The terms without the coefficient are;

$$1^9 1^8(x) 1^7 x^2 1^6(x)^3 1^5(x)^4$$

From Pascal triangle, the coefficients when n =9 are;

$$1 \quad 9 \quad 36 \quad 84 \quad 126 \quad 126 \quad 84 \quad 36 \quad 9 \quad 1$$

$$\text{Therefore } (1 + x)^9 = 1 + 9x + 36x^2 + 84 x^3 \dots\dots\dots$$

$$(0.98)^8 = 1 + 9 x (-0.02) + 36 + (- 0.02)^2 + 84 (- 0.02)^3$$

$$\begin{aligned}
 &= 1 - 0.18 + 0.0144 - 0.000672 \\
 &= 0.833728 \\
 &= 0.834 \text{ (3 D.P)}
 \end{aligned}$$

**Example**

Expand  $(1 + \frac{1}{2})^{10}$  upto the term in  $x^3$  in ascending powers of hence find the value of  $(0.005)^{10}$  correct to four decimal places.

**Solution**

$$\begin{aligned}
 &= 1 + 10\left(\frac{1}{2}x\right) + 45\left(\frac{1}{2}x\right)^2 + 120\left(\frac{1}{2}x\right)^3 \\
 &= 1 + 10 \times \frac{1}{2}x + 45 \times \frac{1}{4}x^2 + 120 \times \frac{1}{8}x^3 \\
 &= 1 + 5x + \frac{45}{4}x^2 + 15x^3
 \end{aligned}$$

$$(1.005)^{10} = (1 + 0.005)^{10}$$

Here  $\frac{1}{2}x = 0.005$

$$x = 0.010$$

Substituting for  $x = 0.01$  in the expansion

$$\begin{aligned}
 \left(1 + \frac{1}{2}(0.01)\right)^{10} &= 1 + 5 \times 0.01 + \frac{45}{4} \times (0.01)^2 + 15(0.01)^3 \\
 &= 1 + 0.05 + 0.001125 + 0.000015 \\
 &= 1.051140 \\
 &= 1.0511 \text{ (4 decimal places)}
 \end{aligned}$$

End of topic

Did you understand everything?  
If not ask a teacher, friends or anybody and make sure you understand before going to sleep!

## Past KCSE Questions on the topic.

1. (a) Write down the simplest expansion  $(1 + x)^6$   
 (b) Use the expansion up to the fourth term to find the value of  $(1.03)^6$  to the nearest one thousandth.
2. Use binomial expression to evaluate  $(0.96)^5$  correct to 4 significant figures.
3. Expand and simplify  $(3x - y)^4$  hence use the first three terms of the expansion to approximate the value of  $(6 - 0.2)^4$
4. Use binomial expression to evaluate  

$$\left( 2 + \frac{1}{\sqrt{2}} \right)^{\sqrt{2}} \left( 2 - \frac{1}{\sqrt{2}} \right)^{\sqrt{2}}$$
5. (a) Expand the expression  $\left( 1 + \frac{x}{2} \right)^5$  in ascending powers of x, leaving the coefficients as fractions in their simplest form.
6. (a) Expand  $(a - b)^6$   
 (b) Use the first three terms of the expansion in (a) above to find the approximate value of  $(1.98)^6$
7. Expand  $(2 + x)^5$  in ascending powers of x up to the term in  $x^3$  hence approximate the value of  $(2.03)^5$  to 4 s.f
8. (a) Expand  $(1 + x)^5$   
 Hence use the expansion to estimate  $(1.04)^5$  correct to 4 decimal places  
 (b) Use the expansion up to the fourth term to find the value of  $(1.03)^6$  to the nearest one thousandth.
9. Expand and Simplify  $(1-3x)^5$  up to the term in  $x^3$   
 Hence use your expansion to estimate  $(0.97)^5$  correct to decimal places.
10. Expand  $(1 + a)^5$   
 Use your expansion to evaluate  $(0.8)^5$  correct to four places of decimal
11. (a) Expand  $(1 + x)^5$   
 (b) Use the first three terms of the expansion in (a) above to find the approximate value of  $(0.98)^5$

## CHAPTER FIFTY TWO

## COMPOUND PROPORTION AND RATES OF

## Specific Objectives

By the end of the topic the learner should be able to:

- (a) Solve problems involving compound proportions using unitary and ratio methods;
- (b) Apply ratios and proportions to real life situations;
- (c) Solve problems involving rates of work.

## Content

- (a) Proportional parts
- (b) Compound proportions
- (c) Ratios and rates of work
- (d) Proportions applied to mixtures.

## Introduction

## Compound proportions

The proportion involving two or more quantities is called compound proportion. Any four quantities  $a, b, c,$

a and d are in proportion if;

$$\frac{a}{b} = \frac{c}{d}$$

### Example

Find the value of a that makes 2, 5, a and 25 to be in proportion;

### Solution

Since 2, 5, a, and 25 are in proportion

$$\frac{2}{5} = \frac{a}{25}$$

$$5a = 2 \times 25$$

$$a = \frac{2 \times 25}{5}$$

$$a = 10$$

## Continued proportions

In continued proportion, all the ratios between different quantities are the same; but always remember that the relationship exists between two quantities for example:

P : Q

Q : R

R : S

10: 5

16 : 8

4 : 2

Note that in the example, the ratio between different quantities i.e. P:Q, Q:R and R:S are the same i.e. 2:1 when simplified.

Continued proportion is very important when determining the net worth of individuals who own the same business or even calculating the amounts of profit that different individual owners of a company or business should take home.

## Proportional parts

In general, if n is to be divided in the ratio a: b: c, then the parts of n proportional to a, b, c are  $\frac{a}{a+b+c} \times n$ ,

$\frac{b}{a+b+c} \times n$  and  $\frac{c}{a+b+c} \times n$  respectively



**Example**

Omondi, Joel, cheroot shared sh 27,000 in the ratio 2:3:4 respectively. How much did each get?

**Solution**

The parts of sh 27,000 proportional to 2, 3, 4 are

$$\frac{2}{9} \times 27,000 = \text{sh } 6000 \rightarrow \text{Omondi}$$

$$\frac{3}{9} \times 27,000 = \text{sh } 6000 \rightarrow \text{Joel}$$

$$\frac{4}{9} \times 27,000 = \text{sh } 6000 \rightarrow \text{Cheroot}$$

**Example**

Three people – John, Debby and Dave contributed ksh 119, 000 to start a company. If the ratio of the contribution of John to Debby was 12:6 and the contribution of Debby to Dave was 8:4, determine the amount in dollars that every partner contributed.

**Solution**

Ratio of John to Debby's contribution = 12:6 = 2:1

Ratio of Debby to Dave's contribution = 8:4 = 2:1

As you can see, the ratio of the contribution of John to Debby and that of Debby to Dave is in continued proportion.

$$\text{Hence } \frac{\text{John}}{\text{Debby}} = \frac{\text{Debby}}{\text{Dave}} = \frac{2}{1}$$

To determine the ratio of the contribution between the three members, we do the calculation as follows:

John: Debby: Dave

$$12 : 6$$

$$8 : 4$$

We multiply the upper ratio by 8 and the lower ratio by 6, thus the resulting ratio will be:

John: Debby: Dave

$$96 : 48 : 24$$

$$= 4 : 2 : 1$$

The total ratio = 7

The contribution of the different members can then be found as follows:

$$\text{John } \frac{4}{7} \times \text{ksh } 119,000 = \text{ksh } 68,000$$

$$\text{Debby } \frac{2}{7} \times \text{ksh } 119,000 = \text{ksh } 34,000$$

$$\text{Dave } \frac{1}{7} \times \text{ksh } 119,000 = \text{ksh } 17,000$$

John contributed ksh 68, 000 to the company while Debby contributed ksh 34, 000 and Dave contributed ksh 17, 000

### Example 2

You are presented with three numbers which are in continued proportion. If the sum of the three numbers is 38 and the product of the first number and the third number is 144, find the three numbers.

### Solution

Let us assume that the three numbers in continued proportion or Geometric Proportion are  $a$ ,  $ar$  and  $ar^2$  where  $a$  is the first number and  $r$  is the rate.

$$a+ar+ar^2 = 38 \dots\dots\dots (1)$$

The product of the 1<sup>st</sup> and 3<sup>rd</sup> is

$$a \times ar^2 = 144$$

Or

$$(ar)^2 = 144 \dots\dots\dots (2)$$

If we find the square root of  $(ar)^2$ , then we will have found the second number:

$$\sqrt{(ar)^2} = \sqrt{144}$$

$$ar = 12$$

Since the value of the second number is 12, it then implies that the sum of the first and the third number is 26.

We now proceed and look for two numbers whose sum is 26 and product is 144.

Clearly, the numbers are 8 and 18.

Thus, the three numbers that we were looking for are 8, 12 and 18.

Let us work backwards and try to prove whether this is actually true:

$$8 + 12 + 18 = 38$$

What about the product of the first and the third number?

$$8 \times 18 = 144$$

What about the continued proportion

$$\frac{a}{ar} = \frac{ar}{ar^2} = \frac{2}{3}$$

The numbers are in continued proportion

### Example

Given that  $x: y = 2:3$ , Find the ratio  $(5x - 4y): (x + y)$ .

### Solution

Since  $x: y = 2: 3$

$$\frac{x}{2} = \frac{y}{3} = k,$$

$$x = 2k \quad \text{and} \quad y = 3k$$

$$(5x - 4y): (x + y) = (10k - 12k) : (2k + 3k)$$

$$= -2k: 5k$$

$$= - 2: 5$$

### Example

If  $\frac{a}{b} = \frac{c}{d}$ , show that  $\frac{a-3b}{b-3a} = \frac{c-3d}{d-3c}$ .

### Solution

$$\frac{a}{b} = \frac{c}{d} \rightarrow \frac{a}{c} = \frac{b}{d}$$

$$\frac{a}{b} = \frac{b}{d} = k$$

$$a = kc \quad \text{and} \quad b = kd$$

Substituting  $kc$  for  $a$  and  $kd$  for  $b$  in the expression  $\frac{a-3b}{b-3a}$

$$\frac{kc-3kd}{kd-3kc} = \frac{k(c-3d)}{k(d-3c)}$$

$$\frac{c-3d}{d-3c}$$

Therefore expression  $\frac{a-3b}{b-3a} = \frac{c-3d}{d-3c}$

## Rates of work and mixtures

### Examples

195 men working 10 hour a day can finish a job in 20 days. How many men employed to finish the job in 15 days if they work 13 hours a day.

### Solution:

Let x be the no. of men required

Days	hours	Men
20	10	195
15	13	x

$$20 \times 10 \times 195 = 15 \times 13 \times x$$

$$x = \frac{20 \times 10 \times 195}{15 \times 13} = 200 \text{ men}$$

### Example

Tap P can fill a tank in 2 hrs, and tap Q can fill the same tank in 4 hrs. Tap R can empty the tank in 3 hrs.

- If tap R is closed, how long would it take taps P and Q to fill the tank?
- Calculate how long it would take to fill the tank when the three taps P, Q and R. are left running?

### Solution

a) Tap P fills  $\frac{1}{2}$  of the tank in 1 h.

Tap Q fills  $\frac{1}{4}$  of the tank in 1 h.

Tap R empties  $\frac{1}{3}$  of the tank in 1 h.

In one hour, P and Q fill  $\frac{1}{2} + \frac{1}{4} = \frac{3}{4}$  of the tank

Therefore  $\frac{3}{4}$  of the tank is filled in 1 h.

$$\begin{aligned} \text{Time taken to fill the tank } \left(\frac{4}{3}\right) &= \left(\frac{4}{\frac{3}{4}}\right) \text{h} \\ &= \frac{4}{3} \text{ h} \end{aligned}$$

b) In 1 h, P and Q fill  $\frac{3}{4}$  of tank while R empties  $\frac{1}{3}$  of the tank.

When all taps are open,  $\left(\frac{1}{2} + \frac{1}{4} - \frac{1}{3} = \frac{5}{12}\right)$  of the tank is filled in 1 hour.

$\frac{5}{12}$  of tank is filled in 1 hour.

$$\begin{aligned} \text{Therefore time required to fill the tank } \frac{12}{5} &= \left(\frac{12}{\frac{5}{12}}\right) \times 1 \text{ h} \\ &= 2 \frac{2}{5} \text{ h} \end{aligned}$$

### Example

In what proportion should grades of sugars costing sh.45 and sh.50 per kilogram be mixed in order to produce a blend worth sh.48 per kilogram?

### Solution

#### Method 1

Let n kilograms of the grade costing sh.45 per kg be mixed with 1 kilogram of grade costing sh.50 per kg.

Total cost of the two blends is sh.(45n+50)

The mass of the mixture is (n + 1) kg

Therefore total cost of the mixture is (n + 1)48

$$45n + 50 = 48(n + 1)$$

$$45n + 50 = 48n + 48$$

$$50 = 3n + 48$$

$$2 = 3n$$

isabokemicah@gmail.com

$$n = \frac{2}{3}$$

The two grades are mixed in the proportion  $\frac{2}{3} : 1 = 2 : 3$

## Method 2

Let x kg of grade costing sh 45 per kg be mixed with y kg of grade costing sh.50 per kg. The total cost will be sh.(45x + 50 y)

Cost per kg of the mixture is sh.  $\frac{45x+50y}{x+y}$

$$\frac{45x+50y}{x+y} = 48$$

$$45x + 50y = 48(x + y)$$

$$45x + 50y = 48x + 48y$$

$$2y = 3x$$

$$\frac{x}{y} = \frac{2}{3}$$

The proportion is x : y = 2:3

End of topic

Did you understand everything?

If not ask a teacher, friends or anybody and make sure you understand before going to sleep!

## Past KCSE Questions on the topic.

1. Akinyi bought maize and beans from a wholesaler. She then mixed the maize and beans the ratio 4:3 she brought the maize at Kshs. 12 per kg and the beans 4 per kg. If she was to make a profit of 30% what should be the selling price of 1 kg of the mixture?
2. A rectangular tank of base 2.4 m by 2.8 m and a height of 3 m contains 3,600 liters of water initially. Water flows into the tank at the rate of 0.5 litres per second

Calculate the time in hours and minutes, required to fill the tank

3. A company is to construct a parking bay whose area is  $135\text{m}^2$ . It is to be covered with concrete slab of uniform thickness of 0.15. To make the slab cement, Ballast and sand are to be mixed so that their masses are in the ratio 1: 4: 4. The mass of  $\text{m}^3$  of dry slab is 2, 500kg.

Calculate

- (a) (i) The volume of the slab  
(ii) The mass of the dry slab  
(iii) The mass of cement to be used
- (b) If one bag of the cement is 50 kg, find the number of bags to be purchased
- (a) If a lorry carries 7 tonnes of sand, calculate the number of lorries of sand to be purchased.
4. The mass of a mixture A of beans and maize is 72 kg. The ratio of beans to maize is 3:5 respectively
- (a) Find the mass of maize in the mixture
- (b) A second mixture of B of beans and maize of mass 98 kg in mixed with A. The final ratio of beans to maize is 8:9 respectively. Find the ratio of beans to maize in B
5. A retailer bought 49 kg of grade 1 rice at Kshs. 65 per kilogram and 60 kg of grade II rice at Kshs 27.50 per kilogram. He mixed the tow types of rice.
- (a) Find the buying price of one kilogram of the mixture
- (b) He packed the mixture into 2 kg packets
- (i) If he intends to make a 20% profit find the selling price per packet
- (ii) He sold 8 packets and then reduced the price by 10% in order to attract customers. Find the new selling price per packet.
- (iii) After selling  $\frac{1}{3}$  of the remainder at reduced price, he raised the price so as to realize the original goal of 20% profit overall. Find the selling price per packet of the remaining rice.
6. A trader sells a bag of beans for Kshs 1,200. He mixed beans and maize in the ration 3: 2. Find how much the trader should he sell a bag of the mixture to realize the same profit?
7. Pipe A can fill an empty water tank in 3 hours while, pipe B can fill the same tank in 6 hours, when the tank is full it can be emptied by pipe C in 8 hours. Pipes A and B are opened at the same time when the tank is empty.
- If one hour later, pipe C is also opened, find the total time taken to fill the tank
8. A solution whose volume is 80 litres is made 40% of water and 60% of alcohol. When litres of water are added, the percentage of alcohol drops to 40%
- (a) Find the value of x
- (b) Thirty litres of water is added to the new solution. Calculate the percentage
- (c) If 5 litres of the solution in (b) is added to 2 litres of the original solution, calculate in the simplest form, the ratio of water to that of alcohol in the resulting solution

9. A tank has two inlet taps P and Q and an outlet tap R. when empty, the tank can be filled by tap P alone in  $4\frac{1}{2}$  hours or by tap Q alone in 3 hours. When full, the tank can be emptied in 2 hours by tap R.
- (a) The tank is initially empty. Find how long it would take to fill up the tank
- (i) If tap R is closed and taps P and Q are opened at the same time (2mks)
- (ii) If all the three taps are opened at the same time
- (b) The tank is initially empty and the three taps are opened as follows
- P at 8.00 a.m
- Q at 8.45 a.m
- R at 9.00 a.m
- (i) Find the fraction of the tank that would be filled by 9.00 a.m
- (ii) Find the time the tank would be fully filled up
10. Kipketer can cultivate a piece of land in 7 hrs while Wanjiru can do the same work in 5 hours. Find the time they would take to cultivate the piece of land when working together.
11. Mogaka and Ondiso working together can do a piece of work in 6 days. Mogaka, working alone, takes 5 days longer than Onduso. How many days does it take Onduso to do the work alone.
12. Wainaina has two dairy farms A and B. Farm A produces milk with  $3\frac{1}{4}$  percent fat and farm B produces milk with  $4\frac{1}{4}$  percent fat.
- (a) (i) The total mass of milk fat in 50 kg of milk from farm A and 30kg of milk from farm B.
- (ii) The percentage of fat in a mixture of 50 kg of milk A and 30 kg of milk from B
- (b) Determine the range of values of mass of milk from farm B that must be used in a 50 kg mixture so that the mixture may have at least 4 percent fat.
13. A construction firm has two tractors  $T_1$  and  $T_2$ . Both tractors working together can complete the work in 6 days while  $T_1$  alone can complete the work in 15 days. After the two tractors had worked together for four days, tractor  $T_1$  broke down.
- Find the time taken by tractor  $T_2$  complete the remaining work.



## CHAPTER FIFTY THREE

## GRAPHICAL METHODS

## Specific Objectives

By the end of the topic the learner should be able to:

- (a) Makes a table of values from given relations;
- (b) Use the table of values to draw the graphs of the relations;
- (c) Determine and interpret instantaneous rates of change from a graph;
- (d) Interpret information from graphs;
- (e) Draw and interpret graphs from empirical data;
- (f) Solve cubic equations graphically;
- (g) Draw the line of best fit;
- (h) Identify the equation of a circle;
- (i) Find the equation of a circle given the centre and the radius;
- (j) Determine the centre and radius of a circle and draw the circle on a cartesian plane.

## Content

- (a) Tables and graphs of given relations
- (b) Graphs of cubic equations
- (c) Graphical solutions of cubic equations
- (d) Average rate of change
- (e) Instantaneous rate of change

- (f) Empirical data and their graphs
- (g) The line of best fit
- (h) Equation of a circle
- (i) Finding of the equation of a circle
- (j) Determining of the centre and radius of a circle.

## Introduction

These are ways or methods of solving mathematical functions using graphs.

## Graphing solutions of cubic Equations

A cubic equation has the form

$$ax^3 + bx^2 + cx + d = 0$$

where a, b, c and d are constants

It must have the term in  $x^3$  or it would not be cubic (and so  $a \neq 0$ ), but any or all of  $b$ ,  $c$  and  $d$  can be zero. For instance,

$$x^3 - 6x^2 + 11x - 6 = 0, \quad 4x^3 + 57 = 0, \quad x^3 + 9x = 0$$

are all cubic equations.

The graphs of cubic equations always take the following shapes.

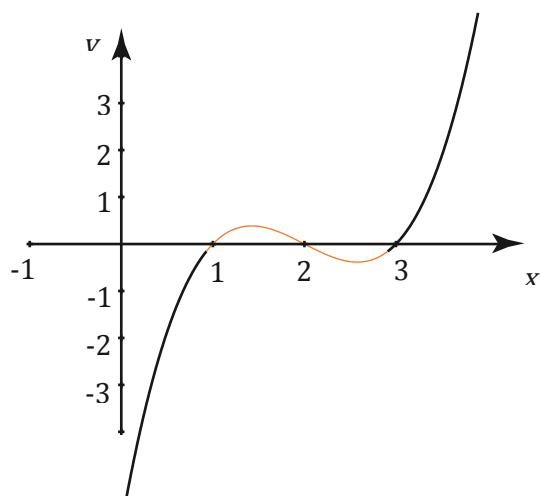

$$Y = x^3 - 6x^2 + 11x - 6 = 0.$$

Notice that it starts low down on the left, because as  $x$  gets large and negative so does  $x^3$  and it finishes higher to the right because as  $x$  gets large and positive so does  $x^3$ . The curve crosses the  $x$ -axis three times, once where  $x = 1$ , once where  $x = 2$  and once where  $x = 3$ . This gives us our three separate solutions.

### Example

- (a) Fill in the table below for the function  $y = -6 + x + 4x^2 + x^3$  for  $-4 \leq x \leq 2$

x	-4	-3	-2	-1	0	1	2
-6	-6	-6	-6	-6	-6	-6	-6
x	-4	-3	-2	-1	0	1	2
4x <sup>2</sup>			16			4	
x <sup>3</sup>							
y							

(b) Using the grid provided draw the graph for  $y = -6 + x + 4x^2 + x^3$  for  $-4 \leq x \leq 2$

(c) Use the graph to solve the equations:-

$$-6 + x + 4x^2 + x^3 = 0$$

$$.x^3 + 4x^2 + x - 4 = 0$$

$$-2 + 4x^2 + x^3 = 0$$

Solution

The table shows corresponding values of x and y for  $y = -6 + x + 4x^2 + x^3$

X	-4	-3	-2	-1	0	1	2
-6	-6	-6	-6	-6	-6	-6	-6
X	-4	-3	-2	-1	0	1	2
4x <sup>2</sup>	64	36	16	4	0	4	16
X <sup>3</sup>	-64	-27	-8	-1	0	1	8
Y=-6+x+4x <sup>2</sup> +x <sup>3</sup>	-10	0	0	-4	-6	0	20

From the graph the solutions for x are  $x = -3$ ,  $x = -2$ ,  $x = 1$

1. To solve equation  $y = x^3 + 4x^2 + x - 6$  we draw a straight line from the difference of the two

equations and then we read the coordinates at the point of the intersecion of the curve and the straight line

$$y = x^3 + 4x^2 + x - 6$$

$$0 = x^3 + 4x^2 + x - 4$$

$$y = -2$$

solutions 0.8, -1.5 and -3.2

$$x \quad 1 \quad 0 \quad -2$$

$$y = x^3 + 4x^2 + x - 6$$

$$y \quad -3 \quad -4 \quad -8$$

$$0 = x^3 + 4x^2 + 0 - 2$$

$$y = x - 4$$

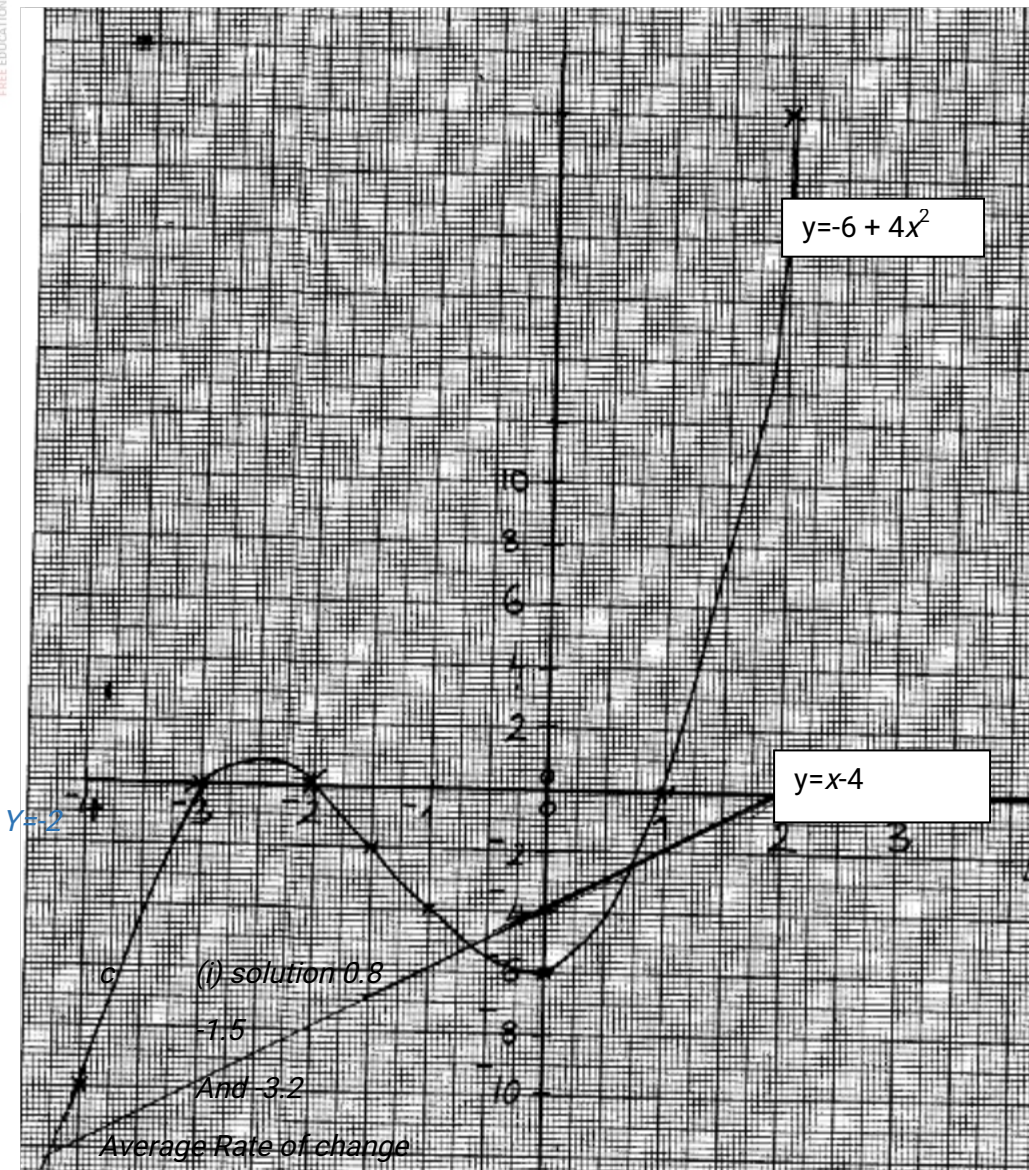

### Defining the Average Rate of Change

The notion of average rate of change can be used to describe the change in any variable with respect to another. If you have a graph that represents a plot of data points of the form  $(x, y)$ , then the average rate of change between any two points is the change in the  $y$  value divided by the change in the  $x$  value.



isabokemicah@gmail.com

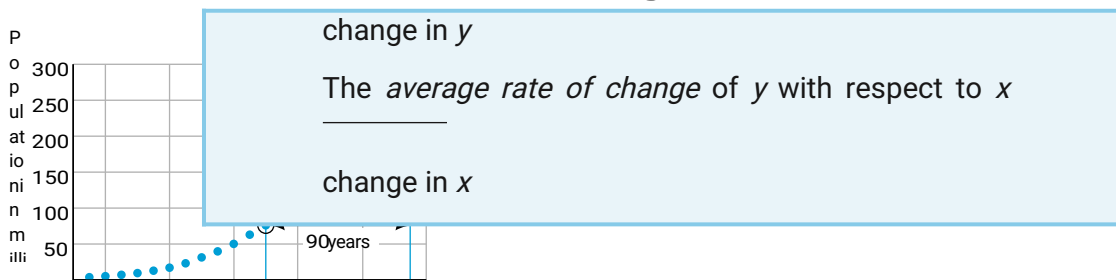

Note;

- The rate of change of a straight (the slope) line is the same between all points along the line
- The rate of change of a quadratic function is not constant (does not remain the same)

**Example**

The graph below shows the rate of growth of a plant, from the graph, the change in height between day 1 and day 3 is given by  $7.5 \text{ cm} - 3.8 \text{ cm} = 3.7 \text{ cm}$ .

Average rate of change is  $\frac{3.7 \text{ cm}}{2 \text{ days}} = 1.85 \text{ cm /day}$

The average rate of change for the next two days is  $\frac{1.3 \text{ cm}}{2 \text{ days}} = 0.65 \text{ cm/day}$

Note;

- The rate of growth in the first 2 days was  $1.85 \text{ cm/day}$  while that in the next two days is only  $0.65 \text{ cm /day}$ . These rates of change are represented by the gradients of the lines PQ and QR respectively.

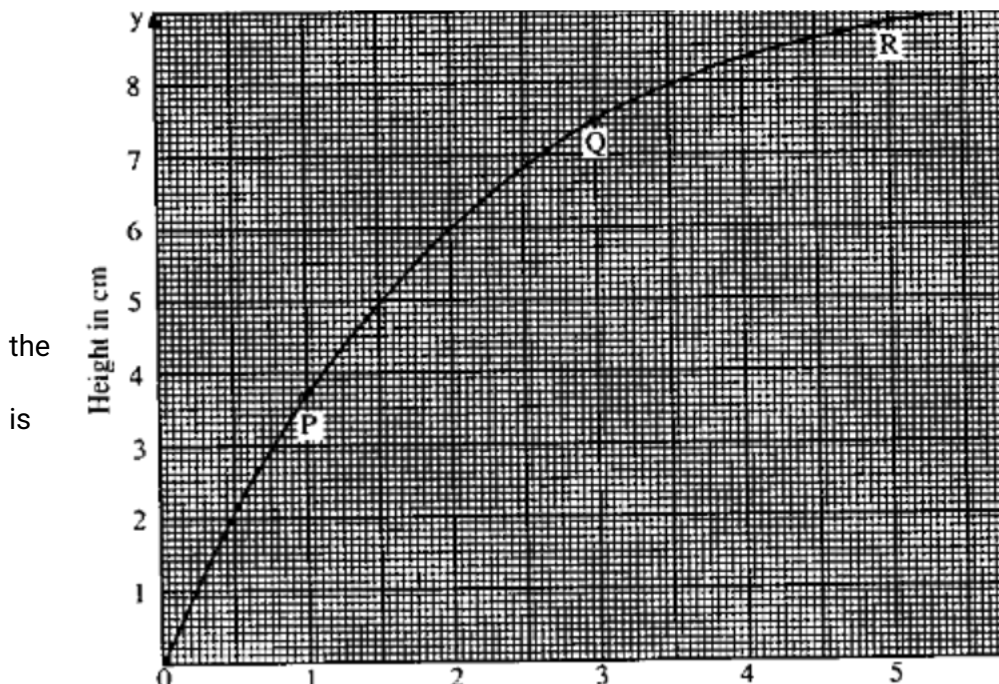

Number of days

The gradient of the straight line is 20, which is constant. The gradient represents rate of distance with time (speed) which is 20 m/s.

For free KCSE Notes, Exams, and Past Papers Visit <https://Teacher.co.ke/>

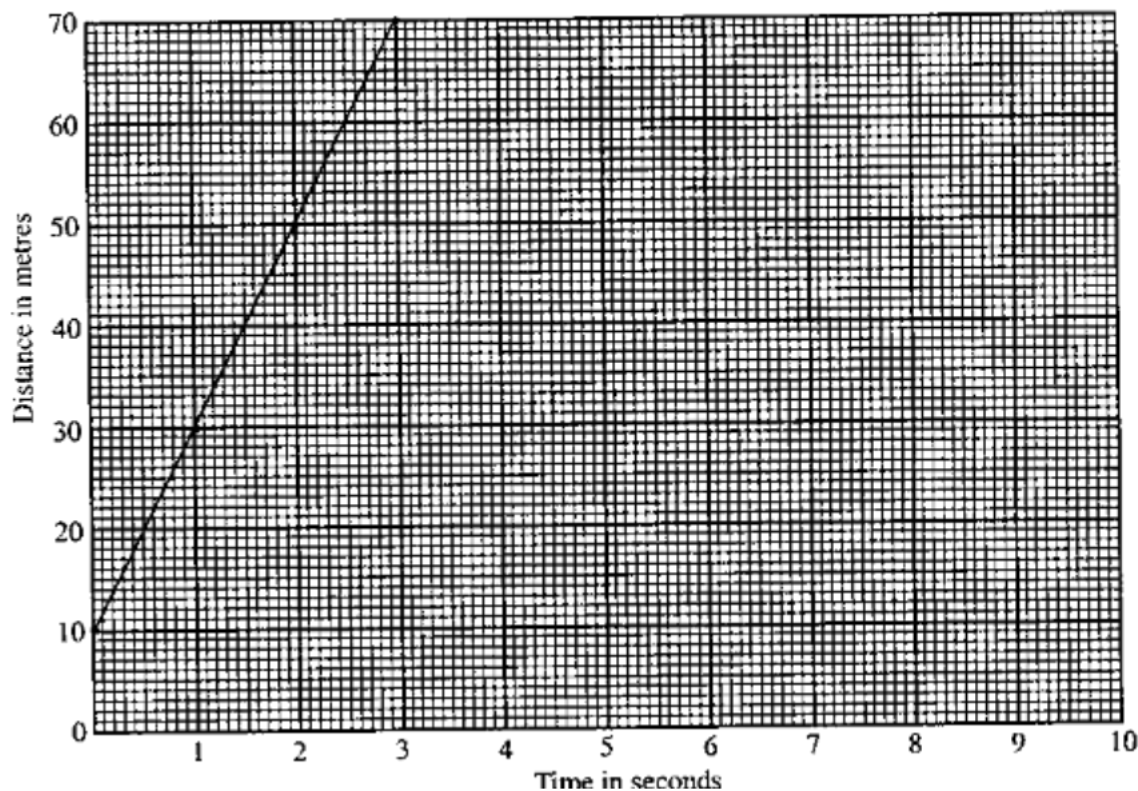

Rate of change at an instant

We have seen that to find the rate of change at an instant (particular point), we:

- Draw a tangent to the curve at that point
- Determine the gradient of the tangent

The gradient of the tangent to the curve at the point is the rate of change at that point.

## Empirical graphs

An Empirical graph is a graph that you can use to evaluate the fit of a distribution to your data by drawing the line of best fit. This is because raw data usually have some errors.

### Example

The table below shows how length  $l$  cm of a metal rod varies with increase in temperature  $T$  ( $^{\circ}\text{C}$ ).

<i>Temperature</i>	0	1	2	3	5	6	7	8
<i>Degrees C</i>								
<i>Length cm</i>	4.0	4.3	4.7	4.9	5.0	5.9	6.0	6.4

Solution

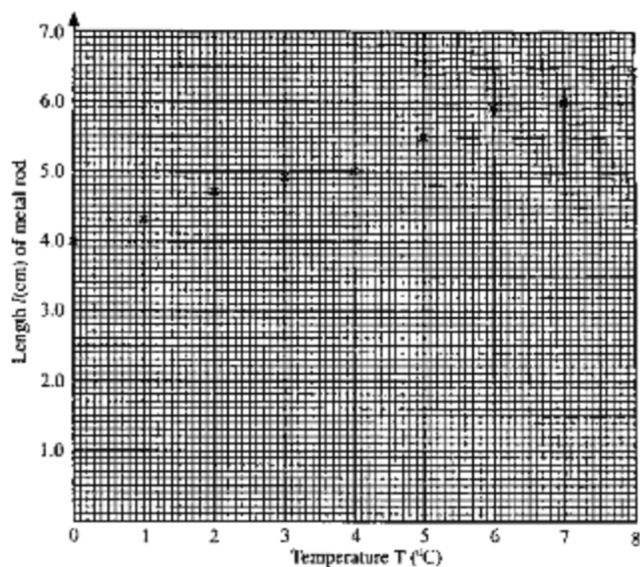

NOTE;

- There is a linear relation between length and temperature.
- We therefore draw a line of best fit that passes through as many points as possible.
- The remaining points should be distributed evenly below and above the line



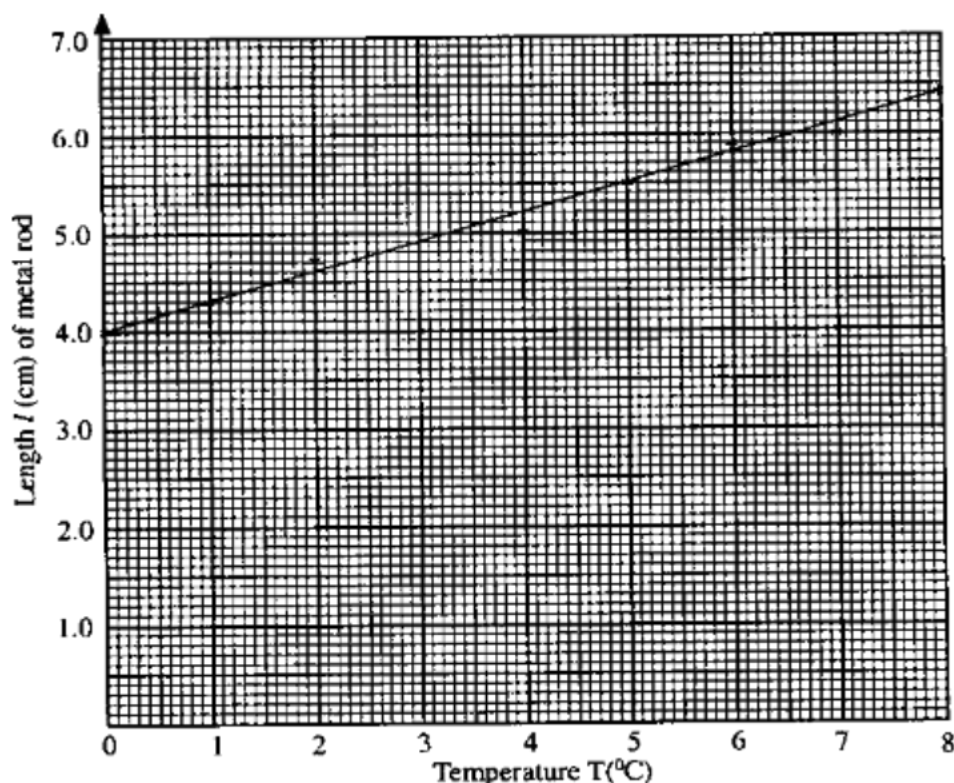

The line cuts the y – axis at (0, 4) and passes through the point (5, 5.5). Therefore, the gradient of the line is  $\frac{1.5}{5} = 0.3$ . The equation of the line is  $l = 0.3T + 4$ .

### Reduction of Non-linear Laws to Linear Form.

When we plot the graph of  $xy=k$ , we get a curve. But when we plot  $y$  against  $\frac{1}{x}$ , we get a straight line whose gradient is  $k$ . The same approach is used to obtain linear relations from non-linear relations of the form  $y = kx^n$ .

#### Example

The table below shows the relationship between  $A$  and  $r$

$r$	1	2	3	4	5
$A$	3.1	12.6	28.3	50.3	78.5



It is suspected that the relation is of the form  $A=Kr^2$ .By drawing a suitable graph,verify the law connecting A and r and determine the value of K.

**Solution**

If we plot A against  $r^2$ ,we should get a straight line.

$r$	1	2	3	4	5
$A$	3.1	12.6	28.3	50.3	78.5
$r^2$	1	4	9	16	25

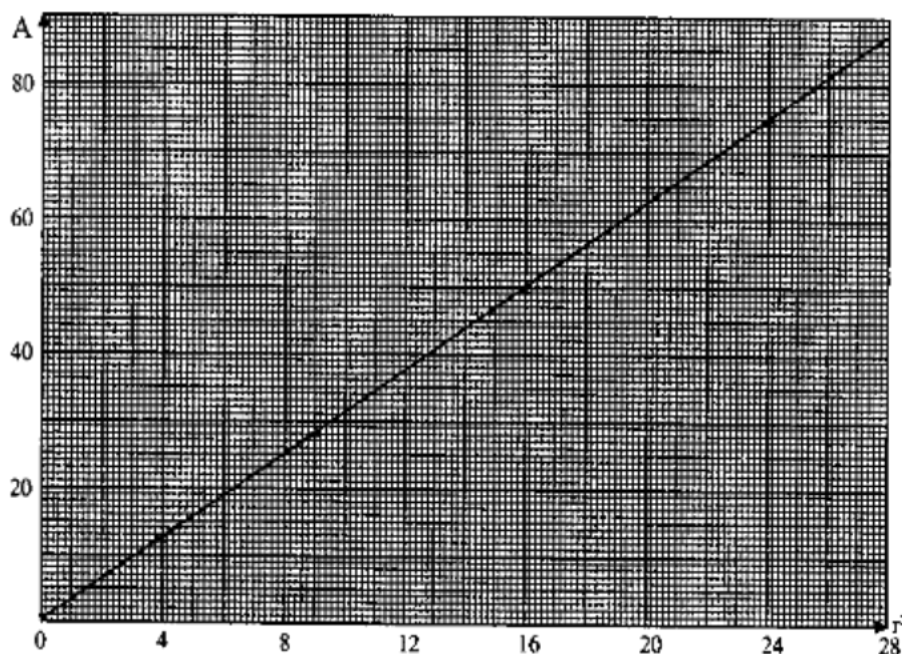

Since the graph of A against  $r^2$ is a straight line, the law  $A =kr^2$ holds.The gradient of this line is 3.1 to one decimal place. This is the value of k.

**Example**

From 1960 onwards, the population P of Kisumu is believed to obey a law of the form  $P =kA^t$ ,Where k and A are constants and t is the time in years reckoned from 1960.The table below shows the population of the town since 1960.

$r$	1960	1965	1970	1975	1980	1985	1990
-----	------	------	------	------	------	------	------

$p$	5000	6080	7400	9010	10960	13330	16200
-----	------	------	------	------	-------	-------	-------

By plotting a suitable graph, check whether the population growth obeys the given law. Use the graph to estimate the value of A.

**Solution**

The law to be tested is  $P = kA^t$ . Taking logs of both sides we get  $\log P = \log k + t \log A$ .  $\log P = \log k + t \log A$ , which is in the form  $y = mx + c$ . Thus we plot  $\log P$  against  $t$ . (Note that  $\log A$  is a constant). The below shows the corresponding values of  $t$  and  $\log p$ .

$t$	1960	1965	1970	1975	1980	1985	1990
$\log P$	3.699	3.784	3.869	3.955	4.040	4.125	4.210

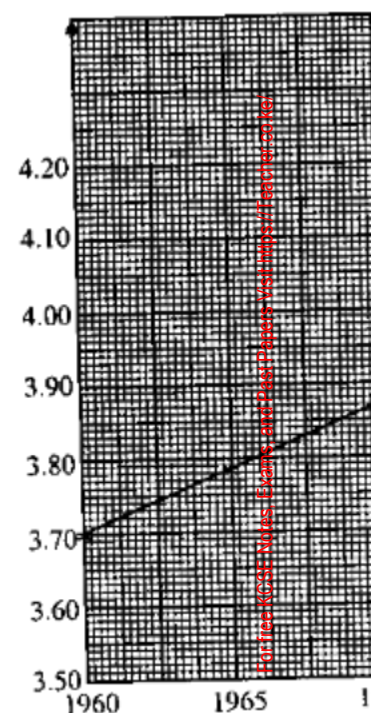

Since the graph is a straight line, the law  $P = kA^t$  holds.

$\log A$  is given by the gradient of the straight line. Therefore,  $\log A = 0.017$ .

Hence,  $A = 1.04$

$\log k$  is the vertical intercept.

Hence  $\log k = 3.69$

Therefore  $k = 4898$

Thus, the relationship is  $P = 4898 (1.04)^t$

**Note;**

- Laws of the form  $y = kA^x$  can be written in the linear form as:  $\log y = \log k + x \log A$  (by taking logs of both sides)

- When  $\log y$  is plotted against  $x$ , a straight line is obtained. Its gradient is  $\log A$  and the intercept is  $\log k$ .
- The law of the form  $y = kx^n$ , where  $k$  and  $n$  are constants can be written in linear form as;
- $\log y = \log k + n \log x$ .
- We therefore plot  $\log y$  is plotted against  $\log x$ .
- The gradient of the line gives  $n$  while the vertical intercept is  $\log k$

### Summary

For the law  $y = d + cx^2$  to be verified it is necessary to plot a graph of the variables in a modified form as follows  $y = d + cx^2$  is compared with  $y = mx + c$  that is  $y = cx^2 + d$

- Y is plotted on the y axis
- $x^2$  is plotted on the x axis
- The gradient is  $c$
- The vertical axis intercept is  $d$

For the law  $y - a = b\sqrt{x}$  to be verified it is necessary to plot a graph of the variables in a Modified form as follows

$y - a = b\sqrt{x}$ , i.e.  $y = b\sqrt{x} + a$  which is compared with  $y = mx + c$

- $y$  should be plotted on the y axis
- $\sqrt{x}$  should be plotted on the x axis
- The gradient is  $b$
- The vertical axis intercept is  $a$

For the law  $y - e = \frac{f}{x}$  to be verified it is necessary to plot a graph of the variables in a

Modified form as follows. The law  $y - e = \frac{f}{x}$  is  $f\left(\frac{1}{x}\right) + e$  compared with  $y = mx + c$ .

- $y$  should be plotted on the vertical axis
- $\frac{1}{x}$  should be plotted on the horizontal axis
- The gradient is  $f$
- The vertical axis intercept is  $e$

For the law  $y - cx = bx^2$  to be verified it is necessary to plot a graph of the variables in a

Modified form as follows. The law  $y - cx = bx^2$  is  $\frac{y}{x} = bx + c$  compared with  $y = mx + c$ ,

- i.)  $\frac{y}{x}$  should be plotted on y axis
- ii.) X should be plotted on x axis
- iii.) The gradient is b
- iv.) The vertical axis intercept is c

For the law  $y = \frac{a}{x} + bx$  to be verified it is necessary to plot a graph of the variables in a  $ax$

Modified form as follows. The law  $\frac{y}{x} = a\left(\frac{1}{x^2}\right) + b$  compared with  $y = mx + c$

- i.)  $\frac{y}{x}$  should be plotted on the vertical axis
- ii.)  $\frac{1}{x^2}$  should be plotted on the horizontal axis
- iii.) The gradient is a
- iv.) The vertical intercept is b

### Equation of a circle

A circle is a set of all points that are of the same distance  $r$  from a fixed point. The figure below is a circle centre  $(0,0)$  and radius 3 units

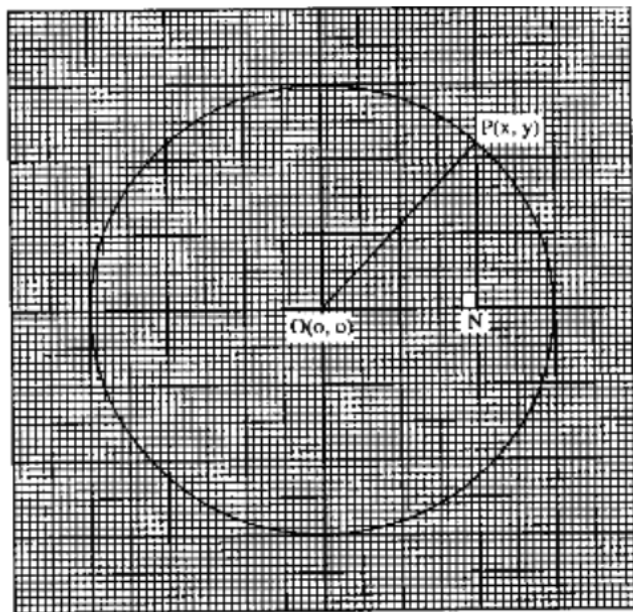

$P(x,y)$  is a point on the circle. Triangle PON is right – angled at N.  
By Pythagoras' theorem;

$$ON^2 + PN^2 = OP^2$$

But  $ON = x$ ,  $PN = y$  and  $OP = 3$ . Therefore,  $x^2 + y^2 = 3^2$

**Note;**

The general equation of a circle centre  $(0,0)$  and radius  $r$  is  $x^2 + y^2 = r^2$

**Example**



Find the equation of a circle centre (0, 0) passing through (3, 4)

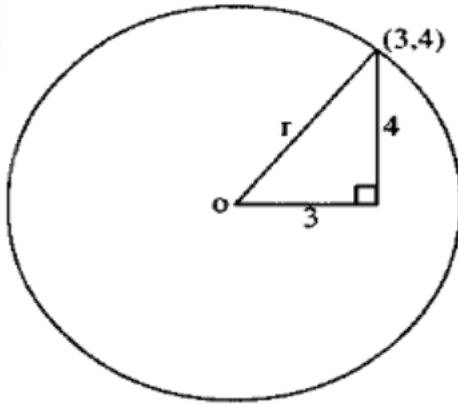

**Solution**

Let the radius of the circle be  $r$   
From Pythagoras theorem;

$$r = \sqrt{3^2 + 4^2}$$

$$r = 5$$

**Example**

Consider a circle centre (5, 4) and radius 3 units.

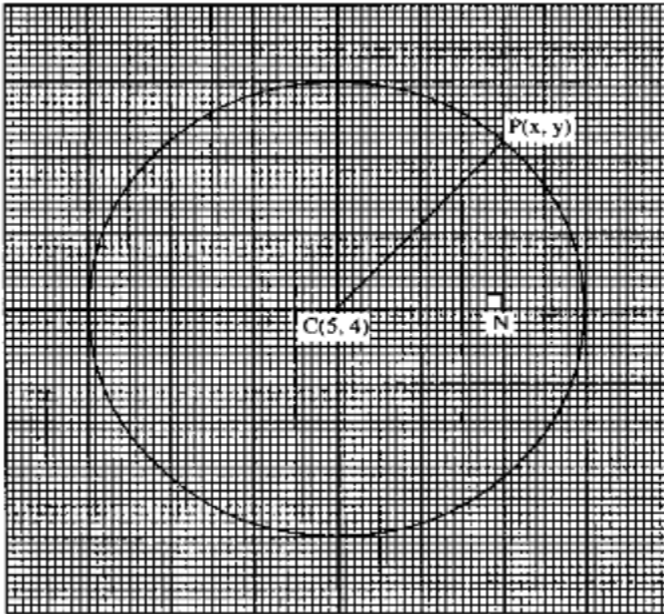

**Solution**

In the figure below triangle CNP is right angled at N. By pythagoras theorem;  
 $CN^2 + NP^2 = CP^2$

But  $CN = (x - 5)$ ,  $NP = (y - 4)$  and  $CP = 3$  units.

Therefore,  $(x-5)^2 + (y-4)^2 = 3^2$  this is the equation of a circle.

Note;

The equation of a circle centre ( a,b) and radius r units is given by;

$$(x-a)^2 + (y-b)^2 = (r)^2$$

### Example

Find the equation of a circle centre (-2 ,3) and radius 4 units

### Solution

General equation of the circle is  $(x-a)^2 + (y-b)^2 = r^2$  .Therefore a = -2 b =3 and r = 4

$$(x-(-2))^2 + (y-(3))^2 = 4^2$$

$$(x+2)^2 + (y-3)^2 = 16$$

### Example

Line AB is the diameter of a circle such that the co-ordinates of A and B are (-1 ,1) and(5 ,1) respectively.

- Determine the centre and the radius of the circle
- Hence, find the equation of the circle

### Solution

$$a.) \left( \frac{-1+5}{2}, \frac{1+1}{2} \right) = (2,1)$$

$$\text{Radius} = \sqrt{(5-2)^2 + (1-1)^2}$$

$$= \sqrt{3^2} = 3$$

b.) Equation of the circle is ;

$$(x-2)^2 + (y-1)^2 = 3^2$$

$$(x-2)^2 + (y-1)^2 = 9$$

### Example

The equation of a circle is given by  $x^2 - 6x + y^2 + 4y - 3 = 0$ . Determine the centre and radius of the circle.

### Solution

$$x^2 - 6x + y^2 + 4y = 3$$

Completing the square on the left hand side;

$$x^2 - 6x + 9 + y^2 + 4y + 4 = 3 + 9 + 4$$

$$(x-3)^2 + (y+2)^2 = 4 - 3 = 0$$

Therefore centre of the circle is (3,-2) and radius is 4 units. Note that the sign changes to opposite positive sign becomes negative while negative sign changes to positive.

### Example

Write the equation of the circle that has A(1, - 6) and B(5, 2) as endpoints of a diameter.

Method 1: Determine the center using the Midpoint Formula:

$$C \left( \frac{1+5}{2}, \frac{-6+2}{2} \right) \rightarrow C(3, -2)$$

isabokemicah@gmail.com

Determine the radius using the distance formula (center and end of diameter):

$$r = \sqrt{(3-1)^2 + (-2+6)^2} = \sqrt{4+16} = \sqrt{20} = 2\sqrt{5}$$

Equation of circle is:  $(x-3)^2 + (y+2)^2 = 20$

**Method 2:** Determine center using Midpoint Formula (as before):  $C(3,-2)$ .

Thus, the circle equation will have the form  $(x-3)^2 + (y+2)^2 = r^2$

Find  $r^2$  by plugging the coordinates of a point on the circle in for x and y.

Let's use B(5, 2):  $r^2 = (5-3)^2 + (2+2)^2 = 2^2 + 4^2 = 4 + 16 = 20$

Again, we get this equation for the circle:  $(x-3)^2 + (y+2)^2 = 20$

End of topic

Did you understand everything?

If not ask a teacher, friends or anybody and make sure you understand before going to sleep!

## Past KCSE Questions on the topic.

1. The table shows the height metres of an object thrown vertically upwards varies with the time t seconds

The relationship between s and t is represented by the equations  $s = at^2 + bt + 10$  where a and b are constants.

T	0	1	2	3	4	5	6	7	8	9	10
S		45.1						49.9			-80

- (a) (i) Using the information in the table, determine the values of a and b  
 (ii) Complete the table
- (b) (i) Draw a graph to represent the relationship between s and t  
 (ii) Using the graph determine the velocity of the object when t = 5 seconds
2. Data collected from an experiment involving two variables X and Y was recorded as shown in the table below

x	1.1	1.2	1.3	1.4	1.5	1.6
y	-0.3	0.5	1.4	2.5	3.8	5.2

The variables are known to satisfy a relation of the form  $y = ax^3 + b$  where a and b are constants

- (a) For each value of x in the table above, write down the value of  $x^3$   
 (b) (i) By drawing a suitable straight line graph, estimate the values of a and b  
 (ii) Write down the relationship connecting y and x

3. Two quantities P and r are connected by the equation  $p = kr^n$ . The table of values of P and r is given below.

P	1.2	1.5	2.0	2.5	3.5	4.5
R	1.58	2.25	3.39	4.74	7.86	11.5

- a) State a linear equation connecting P and r.  
 b) Using the scale 2 cm to represent 0.1 units on both axes, draw a suitable line graph on the grid provided. Hence estimate the values of K and n.

4. The points which coordinates (5,5) and (-3,-1) are the ends of a diameter of a circle centre A  
 Determine:

- (a) The coordinates of A  
 The equation of the circle, expressing it in form  $x^2 + y^2 + ax + by + c = 0$   
 where a, b, and c are constants each computer sold

5. The figure below is a sketch of the graph of the quadratic function  $y = k(x+1)(x-2)$

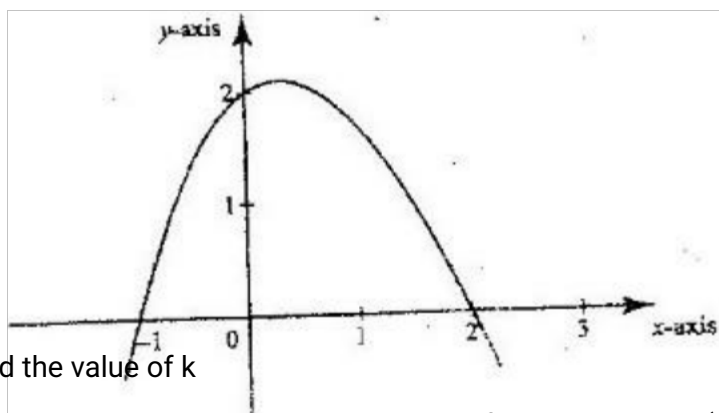

Find the value of k

6. The table below shows the values of the length X ( in metres ) of a pendulum and the corresponding values of the period T ( in seconds) of its oscillations obtained in an experiment.

X ( metres)	0.4	1.0	1.2	1.4	1.6
T ( seconds)	1.25	2.01	2.19	2.37	2.53

- (a) Construct a table of values of log X and corresponding values of log T,



correcting each value to 2 decimal places

- b) Given that the relation between the values of  $\log X$  and  $\log T$  approximate to a linear law of the form  $m \log X + a$  where  $a$  and  $b$  are constants
- (i) Use the axes on the grid provided to draw the line of best fit for the graph of  $\log T$  against  $\log X$ .

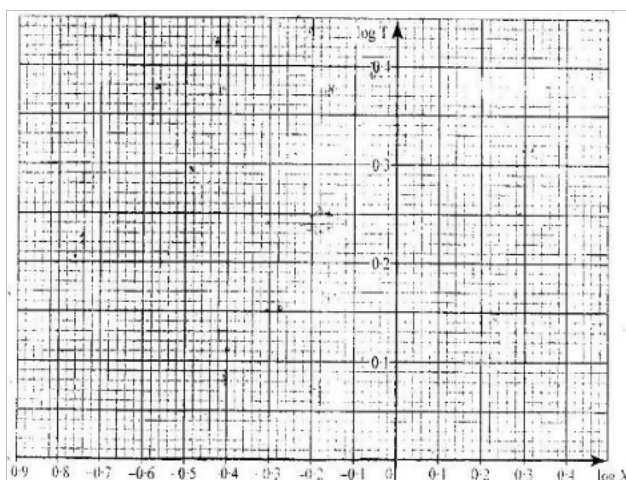

- (ii) Use the graph to estimate the values of  $a$  and  $b$
- (iii) Find, to decimal places the length of the pendulum whose period is 1 second.

7. Data collection from an experiment involving two variables  $x$  and  $y$  was recorded as shown in the table below

X	1.1	1.2	1.3	1.4	1.5	1.6
Y	-0.3	0.5	1.4	2.5	3.8	5.2

The variables are known to satisfy a relation of the form  $y = ax^3 + b$  where  $a$  and  $b$  are constants

- (a) For each value of  $x$  in the table above. Write down the value of  $x^3$
- (b) (i) By drawing a suitable straight line graph, estimate the values of  $a$  and  $b$
- (ii) Write down the relationship connecting  $y$  and  $x$

8. Two variables  $x$  and  $y$ , are linked by the relation  $y = ax^n$ . The figure below shows part of the straight line graph obtained when  $\log y$  is plotted against  $\log x$ .

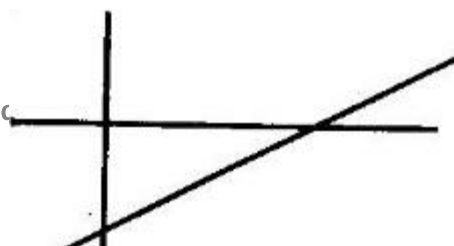

Calculate the value of a and n

9. The luminous intensity  $I$  of a lamp was measured for various values of voltage  $v$  across it. The results were as shown below

V(volts)	30	36	40	44	48	50	54
L (Lux )	708	1248	1726	2320	3038	3848	4380

It is believed that  $V$  and  $I$  are related by an equation of the form  $I = aV^n$  where  $a$  and  $n$  are constant.

- Draw a suitable linear graph and determine the values of  $a$  and  $n$
  - From the graph find
    - The value of  $I$  when  $V = 52$
    - The value of  $V$  when  $I = 2800$
10. In a certain relation, the value of  $A$  and  $B$  observe a relation  $B = CA + KA^2$  where  $C$  and  $K$  are constants. Below is a table of values of  $A$  and  $B$

A	1	2	3	4	5	6
B	3.2	6.75	10.8	15.1	20	25.2

- By drawing a suitable straight line graphs, determine the values of  $C$  and  $K$ .
  - Hence write down the relationship between  $A$  and  $B$
  - Determine the value of  $B$  when  $A = 7$
11. The variables  $P$  and  $Q$  are connected by the equation  $P = ab^q$  where  $a$  and  $b$  are constants. The value of  $p$  and  $q$  are given below

P	6.56	17.7	47.8	129	349	941	2540	6860
Q	0	1	2	3	4	5	6	7

- State the equation in terms of  $p$  and  $q$  which gives a straight line graph
- By drawing a straight line graph, estimate the value of constants  $a$  and  $b$  and give your answer correct to 1 decimal place.

**Novels,Updated ICT,CPA,KASNEB,College,High School Notes & Revision Booklets 0714497530**

## CHAPTER FIFTY FOUR

# PROBABILITY

### Specific Objectives

By the end of the topic the learner should be able to:

- (a) Define probability;
- (b) Determine probability from experiments and real life situations;
- (c) Construct a probability space;
- (d) Determine theoretical probability;
- (e) Differentiate between discrete and continuous probability;
- (f) Differentiate mutually exclusive and independent events;
- (g) State and apply laws of probability;
- (h) Use a tree diagram to determine probabilities.

### Content

- (a) Probability
- (b) Experimental probability
- (c) Range of probability measure  $0 \leq P(x) \leq 1$
- (d) Probability space
- (e) Theoretical probability
- (f) Discrete and continuous probability (simple cases only)
- (g) Combined events (mutually exclusive and independent events)
- (h) Laws of probability
- (i) The tree diagrams.

### Introduction

The likelihood of an occurrence of an event or the numerical measure of chance is called probability.

### Experimental probability

This is where probability is determined by experience or experiment. What is done or observed is the experiment. Each toss is called a trial and the result of a trial is the outcome. The experimental probability of a result is given by (the number of favorable outcomes) / (the total number of trials)

**Example**

A boy had a fair die with faces marked 1 to 6. He threw this die up 50 times and each time he recorded the number on the top face. The result of his experiment is shown below.

<i>face</i>	1	2	3	4	5	6
<i>Number of times a face has shown up</i>	11	6	7	9	9	8

What is the experimental

probability of getting?

- a.) 1   b.) 6

**Solution**

$$a.) P(\text{Event}) = \frac{\text{the number of favorable outcomes}}{\text{the total number of trials}}$$

$$P(1) = 11/50$$

$$b.) P(4) = 9/50$$

**Example**

From the past records, out of the ten matches a school football team has played, it has won seven. How many possible games might the school win in thirty matches ?

**Solution**

$$P(\text{winning in one math}) = 7/10.$$

Therefore the number of possible wins in thirty matches =  $7/10 \times 30 = 21$  matches

**Range of probability Measure**

If  $P(A)$  is the probability of an event A happening and  $P(A')$  is the probability of an event A not happening, Then  $P(A') = 1 - P(A)$  and  $P(A') + P(A) = 1$

Probability are expressed as fractions, decimals or percentages.

**Probability space**

A list of all possible outcomes is probability space or sample space. The coin is such that the head or tail have equal chances of occurring. The events head or tail are said to be equally likely or equiprobable.

**Theoretical probability**

This can be calculated without necessarily using any past experience or doing any experiment. The probability of an event happening =  $\frac{\text{number of favorable outcomes}}{\text{total number of outcomes}}$ .

**Example**

A basket contains 5 red balls, 4 green balls and 3 blue balls. If a ball is picked at random from the basket, find:

- The probability of picking a blue ball
- The probability of not picking a red ball

### Solution

a.) Total number of balls is 12

The number of blue balls is 3

### Solution

a.) therefore,  $P(\text{a blue ball}) = \frac{3}{12}$

b.) The number of balls which are not red is 7.

Therefore  $P(\text{not a red ball}) = \frac{7}{12}$

### Example

A bag contains 6 black balls and some brown ones. If a ball is picked at random the probability that it is black is 0.25. Find the number of brown balls.

### Solution

Let the number of balls be  $x$

Then the probability that a black ball is picked at random is  $\frac{6}{x}$

Therefore  $\frac{6}{x} = 0.25$

$$x = 24$$

The total number of balls is 24

Then the number of brown balls is  $24 - 6 = 18$

### Note:

When all possible outcomes are countable, they are said to be discrete.

## Types of probability

### Combined Events

These are probability of two or more events occurring

### Mutually Exclusive Events

Occurrence of one excludes the occurrence of the other or the occurrence of one event depends on the occurrence of the other. If  $A$  and  $B$  are two mutually exclusive events, then  $P(A \text{ or } B) = P(A) + P(B)$ . For example when a coin is tossed the result will either be a head or a tail.

### Example

i.) If a coin is tossed ;

$$P(\text{head}) + P(\text{tail})$$

$$= \frac{1}{2} + \frac{1}{2} = 1$$

Note;

If [OR] is used then we add

## Independent Events

Two events A and B are independent if the occurrence of A does not influence the occurrence of B and vice versa. If A and B are two independent events, the probability of them occurring together is the product of their individual probabilities .That is;

$$P(A \text{ and } B) = P(A) \times P(B)$$

Note;

When we use [AND] we multiply ,this is the multiplication law of probability.

### Example

A coin is tossed twice. What is the probability of getting a tail in both tosses?

### Solution

The outcome of the 2<sup>nd</sup> toss is independent of the outcome of the first .

Therefore;

$$P(T \text{ and } T) = P(T) \times P(T)$$

$$= \frac{1}{2} \times \frac{1}{2} = \frac{1}{4}$$

### Example

A boy throws a fair coin and a regular tetrahedron with its four faces marked 1,2,3 and 4. Find the probability that he gets a 3 on the tetrahedron and a head on the coin.

### Solution

These are independent events.

$$P(H) = \frac{1}{2}, P(3) = \frac{1}{4}$$

Therefore;

$$P(H \text{ and } 3) = P(H) \times P(3)$$

$$= \frac{1}{2} \times \frac{1}{4}$$

$$= \frac{1}{8}$$

### Example

A bag contains 8 black balls and 5 white ones. If two balls are drawn from the bag, one at a time, find the probability of drawing a black ball and a white ball.

a.) Without replacement

b.) With replacement

### Solution

a.) There are only two ways we can get a black and a white ball: either drawing a white then a black, or drawing a black then a white. We need to find the two probabilities;

$$P(\text{W followed by B}) = P(\text{W and B})$$

$$= \frac{8}{13} \times \frac{5}{12} = \frac{10}{39}$$

b.)  $P(\text{B followed by W}) = P(\text{B and W})$

$$\frac{5}{13} \times \frac{8}{12} = \frac{10}{39}$$

### Note;

The two events are mutually exclusive, therefore.

$$P(\text{W followed by B}) \text{ or } ( \text{B followed by W} ) = P(\text{W followed by B}) + P(\text{B followed by W})$$

$$= P(\text{W and B}) + P(\text{B and W})$$

$$= \frac{40}{156} + \frac{40}{156} = \frac{20}{39}$$

Since we are replacing, the number of balls remains 13.

Therefore;

$$P(\text{W and B}) = \frac{5}{13} \times \frac{8}{13} = \frac{40}{169}$$

$$P(\text{B and W}) = \frac{8}{13} \times \frac{5}{13} = \frac{40}{169}$$

Therefore;

$$P[(\text{W and B}) \text{ or } (\text{B and W})] = P(\text{W and B}) + P(\text{B and W})$$

$$= \frac{40}{169} \times \frac{40}{169} = \frac{80}{169}$$

### Example

Kamau ,Njoroge and Kariuki are practicing archery .The probability of Kamau hitting the target is  $\frac{2}{5}$ ,that of Njoroge hitting the target is  $\frac{1}{4}$  and that of Kariuki hitting the target is  $\frac{3}{7}$  ,Find the probability that in one attempt;

- Only one hits the target
- All three hit the target
- None of them hits the target
- Two hit the target
- At least one hits the target

### Solution

- a.) P(only one hits the target)

$$\begin{aligned} =P(\text{only Kamau hits and other two miss}) &= \frac{2}{5} \times \frac{3}{5} \times \frac{4}{7} \\ &= \frac{6}{35} \end{aligned}$$

$$\begin{aligned} P(\text{only Njoroge hits and other two miss}) &= \frac{1}{4} \times \frac{3}{5} \times \frac{4}{7} \\ &= \frac{3}{35} \end{aligned}$$

$$\begin{aligned} P(\text{only Kariuki hits and other two miss}) &= \frac{3}{7} \times \frac{3}{5} \times \frac{3}{4} \\ &= \frac{27}{140} \end{aligned}$$

$$\begin{aligned} P(\text{only one hits}) &= P(\text{Kamau hits or Njoroge hits or Kariuki hits}) \\ &= \frac{6}{35} + \frac{3}{35} + \frac{27}{140} \\ &= \frac{9}{20} \end{aligned}$$

- b.) P ( all three hit) =  $\frac{2}{5} \times \frac{1}{4} \times \frac{3}{7}$

$$= \frac{3}{70}$$

- c.) P ( none hits) =  $\frac{3}{5} \times \frac{3}{4} \times \frac{4}{7}$

$$= \frac{9}{35}$$

- d.) P ( two hit the target ) is the probability of ;

$$\text{Kamau and Njoroge hit the target and Kariuki misses} = \frac{2}{5} \times \frac{3}{7} \times \frac{4}{7}$$



Njoroge and Kariuki hit the target and Kamau misses =  $1/4 \times 3/7 \times 3/5$

Or

Kamau and Kariuki hit the target and Njoroge misses =  $2/5 \times 3/7 \times 3/4$

$$\begin{aligned}\text{Therefore P (two hit target)} &= (2/5 \times 1/4 \times 4/7) + (1/4 \times 3/7 \times 3/5) + (2/5 \times 3/7 \times 3/4) \\ &= 8/140 + 9/140 + 18/140 \\ &= 1/4\end{aligned}$$

e.) P (at least one hits the target) =  $1 - P$  ( none hits the target)

$$\begin{aligned}&= 1 - 9/35 \\ &= 26/35\end{aligned}$$

Or

$$\begin{aligned}\text{P (at least one hits the target)} &= 1 - P \text{ (none hits the target)} \\ &= 26/35\end{aligned}$$

**Note;**

P (one hits the target) is different from P (at least one hits the target)

## Tree diagram

Tree diagrams allows us to see all the possible outcomes of an event and calculate their probability. Each branch in a tree diagram represents a possible outcome .A tree diagram which represent a coin being tossed three times look like this;

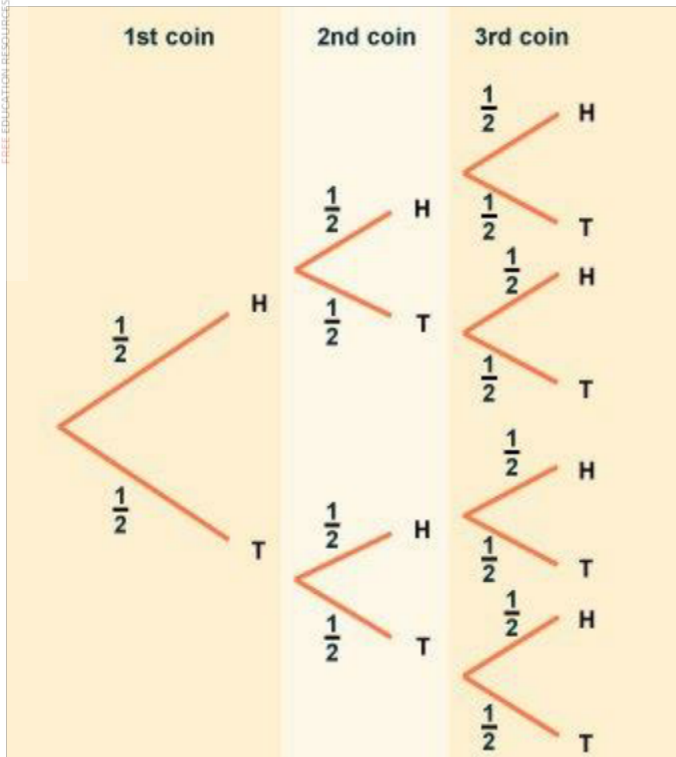

From the tree diagram, we can see that there are eight possible outcomes. To find out the probability of a particular outcome, we need to look at all the available paths (set of branches).

The sum of the probabilities for any set of branches is always 1.

Also note that in a tree diagram to find a probability of an outcome we multiply along the branches and add vertically.

The probability of three heads is:

$$P(H H H) = 1/2 \times 1/2 \times 1/2 = 1/8$$

$$P(2 \text{ Heads and a Tail}) = P(H H T) + P(H T H) + P(T H H)$$

$$= 1/2 \times 1/2 \times 1/2 + 1/2 \times 1/2 \times 1/2 + 1/2 \times 1/2 \times 1/2$$

$$= 1/8 + 1/8 + 1/8$$

$$= \frac{3}{8}$$

**Example**

Bag A contains three red marbles and four blue marbles. Bag B contains 5 red marbles and three blue marbles. A marble is taken from each bag in turn.

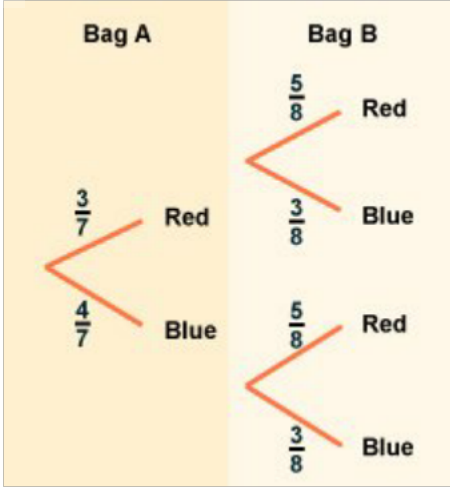

- a.) What is the probability of getting a blue bead followed by a red
- b.) What is the probability of getting a bead of each color

**Solution**

- a.) Multiply the probabilities together

$$P(\text{blue and red}) = \frac{4}{7} \times \frac{5}{8} = \frac{20}{56}$$

$$= \frac{5}{14}$$

- b.)  $P(\text{blue and red or red and blue}) = P(\text{blue and red}) + P(\text{red and blue})$

$$= \frac{4}{7} \times \frac{5}{8} + \frac{3}{7} \times \frac{3}{8}$$

$$= \frac{20}{56} + \frac{9}{56}$$

$$= \frac{29}{56}$$

**Example**

The probability that Omweri goes to Nakuru is  $\frac{1}{4}$ . If he goes to Nakuru, the probability that he will see a flamingo is  $\frac{1}{2}$ . If he does not go to Nakuru, the probability that he will see a flamingo is  $\frac{1}{3}$ . Find the probability that;

- a.) Omweri will go to Nakuru and see a flamingo.
- b.) Omweri will not go to Nakuru yet he will see a flamingo
- c.) Omweri will see a flamingo

**Solution**

Let N stand for going to Nakuru ,N' stand for not going to Nakuru, F stand for seeing a flamingo and F' stand for not seeing a flamingo.

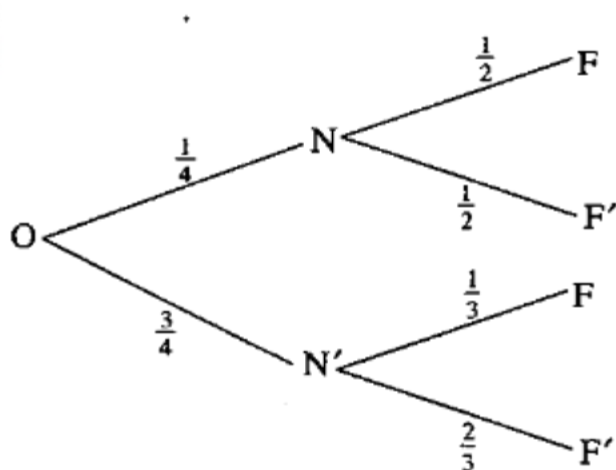

a.)  $P(\text{He goes to Nakuru and sees a flamingo}) = P(N \text{ and } F)$

$$= P(N) \times P(F)$$

$$= \frac{1}{4} \times \frac{1}{2}$$

$$= \frac{1}{8}$$

b.)  $P(\text{He does not go to Nakuru and yet sees a flamingo}) = P(N') \times P(F)$

$$= P(N' \text{ and } F)$$

$$= \frac{3}{4} \times \frac{1}{3}$$

$$= \frac{1}{4}$$

c.)  $P(\text{He sees a flamingo}) = P(N \text{ and } F) \text{ or } P(N' \text{ and } F)$

$$= P(N \text{ and } F) + P(N' \text{ and } F)$$

$$= \frac{1}{8} + \frac{1}{4}$$

$$= \frac{3}{8}$$

End of topic

Did you understand everything?

If not ask a teacher, friends or anybody and make sure you understand before going to sleep!

Past KCSE Questions on the topic.

1. The probabilities that a husband and wife will be alive 25 years from now are 0.7 and 0.9 respectively.  
Find the probability that in 25 years time,
  - (a) Both will be alive
  - (b) Neither will be alive
  - (c) One will be alive
  - (d) At least one will be alive
2. A bag contains blue, green and red pens of the same type in the ratio 8:2:5 respectively. A pen is picked at random without replacement and its colour noted
  - (a) Determine the probability that the first pen picked is
    - (i) Blue
    - (ii) Either green or red
  - (b) Using a tree diagram, determine the probability that
    - (i) The first two pens picked are both green
    - (ii) Only one of the first two pens picked is red.
3. A science club is made up of boys and girls. The club has 3 officials. Using a tree diagram or otherwise find the probability that:
  - (a) The club officials are all boys
  - (b) Two of the officials are girls
4. Two baskets A and B each contain a mixture of oranges and limes, all of the same size. Basket A contains 26 oranges and 13 limes. Basket B contains 18 oranges and 15 limes. A child selected a basket at random and picked a fruit at a random from it.
  - (a) Illustrate this information by a probabilities tree diagram
  - (b) Find the probability that the fruit picked was an orange.
5. In form 1 class there are 22 girls and boys. The probability of a girl completing the secondary education course is  $\frac{3}{4}$  whereas that of a boy is  $\frac{2}{3}$ 
  - (a) A student is picked at random from class. Find the possibility that,
    - (i) The student picked is a boy and will complete the course
    - (ii) The student picked will complete the course
  - (b) Two students are picked at random. Find the possibility that they are a boy and a girl and that both will not complete the course.
6. Three representatives are to be selected randomly from a group of 7 girls and 8 boys. Calculate the probability of selecting two girls and one boy.
7. A poultry farmer vaccinated 540 of his 720 chickens against a disease. Two months later, 5% of the

vaccinated and 80% of the unvaccinated chicken, contracted the disease. Calculate the probability that a chicken chosen random contacted the disease.

8. The probability of three darts players Akinyi, Kamau, and Juma hitting the bulls eye are 0.2, 0.3 and 1.5 respectively.

- (a) Draw a probability tree diagram to show the possible outcomes
- (b) Find the probability that:
  - (i) All hit the bull's eye
  - (ii) Only one of them hit the bull's eye
  - (iii) At most one missed the bull's eye

9. (a) An unbiased coin with two faces, head (H) and tail (T), is tossed three times, list all the possible outcomes.

Hence determine the probability of getting:

- (i) At least two heads
- (ii) Only one tail

(b) During a certain motor rally it is predicted that the weather will be either dry (D) or wet (W). The probability that the weather will be dry is estimated to be  $\frac{7}{10}$ . The probability for a driver to complete (C) the rally during the dry weather is estimated to be  $\frac{5}{6}$ . The probability for a driver to complete the rally during wet weather is estimated to be  $\frac{1}{10}$ . Complete the probability tree diagram given below.

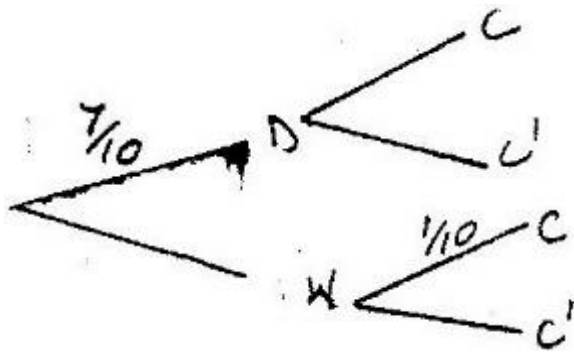

What is the probability that:

- (i) The driver completes the rally?
- (ii) The weather was wet and the driver did not complete the rally?

10. There are three cars A, B and C in a race. A is twice as likely to win as B while B is twice as likely to win as c. Find the probability that.

- a) A wins the race
- b) Either B or C wins the race.

11. In the year 2003, the population of a certain district was 1.8 million. Thirty per cent of the population was in the age group 15 – 40 years. In the same year, 120,000 people in the district visited the Voluntary Counseling and Testing (VCT) centre for an HIV test.

If a person was selected at random from the district in this year. Find the probability that the person visited a VCT centre and was in the age group 15 – 40 years.

12. (a) Two integers  $x$  and  $y$  are selected at random from the integers 1 to 8. If the same integer may be selected twice, find the probability that

- (i)  $|x - y| = 2$
- (ii)  $|x - y|$  is 5 or more
- (iii)  $x > y$

(b) A die is biased so that when tossed, the probability of a number  $r$  showing up, is given by  $p \propto Kr$  where  $K$  is a constant and  $r = 1, 2, 3, 4, 5$  and  $6$  (the number on the faces of the die

- (i) Find the value of  $K$
- (ii) If the die is tossed twice, calculate the probability that the total score is 11

13. Two bags A and B contain identical balls except for the colours. Bag A contains 4 red balls and 2 yellow balls. Bag B contains 2 red balls and 3 yellow balls.

- (a) If a ball is drawn at random from each bag, find the probability that both balls are of the same colour.
- (b) If two balls are drawn at random from each bag, one at a time without replacement, find the probability that:
  - (i) The two balls drawn from bag A or bag B are red
  - (ii) All the four balls drawn are red

14. During inter – school competitions, football and volleyball teams from Mokagu high school took part. The probability that their football and volleyball teams would win were  $\frac{3}{8}$  and  $\frac{4}{7}$  respectively.

Find the probability that

- (a) Both their football and volleyball teams
- (b) At least one of their teams won

15. A science club is made up of 5 boys and 7 girls. The club has 3 officials. Using a tree diagram or otherwise find the probability that:
- The club officials are all boys
  - Two of the officials are girls
16. Chicks on Onyango's farm were noted to have either brown feathers brown or black tail feathers. Of those with black feathers  $\frac{2}{3}$  were female while  $\frac{2}{5}$  of those with brown feathers were male. Otieno bought two chicks from Onyango. One had black tail feathers while the other had brown find the probability that Otieno's chicks were not of the same gender
- was
17. Three representatives are to be selected randomly from a group of 7 girls and 8 boys. Calculate the probability of selecting two girls and one boy
18. The probability that a man wins a game is  $\frac{3}{4}$ . He plays the game until he wins. Determine the probability that he wins in the fifth round.
19. The probability that Kamau will be selected for his school's basketball team is  $\frac{1}{4}$ . If he is selected for the basketball team. Then the probability that he will be selected for football is  $\frac{1}{3}$  if he is not selected for basketball then the probability that he is selected for football is  $\frac{4}{5}$ . What is the probability that Kamau is selected for at least one of the two games?
20. Two baskets A and B each contains a mixture of oranges and lemons. Baskets A contains 26 oranges and 13 lemons. Baskets B contains 18 oranges and 15 lemons. A child selected a basket at random and picked at random a fruit from it. Determine the probability that the fruit picked an orange.



## CHAPTER FIFTY FIVE

## VECTORS

## Specific Objectives

By the end of the topic the learner should be able to:

- Locate a point in two and three dimension co-ordinate systems;
- Represent vectors as column and position vectors in three dimensions;
- Distinguish between column and position vectors;
- Represent vectors in terms of  $\mathbf{i}$ ,  $\mathbf{j}$ , and  $\mathbf{k}$ ;
- Calculate the magnitude of a vector in three dimensions;
- Use the vector method in dividing a line proportionately;
- Use vector method to show parallelism;
- Use vector method to show collinearity;
- State and use the ratio theorem,
- Apply vector methods in geometry.

## Content

- Coordinates in two and three dimensions
- Column and position vectors in three dimensions
- Column vectors in terms of unit vectors  $\mathbf{i}$ ,  $\mathbf{j}$ , and  $\mathbf{k}$
- Magnitude of a vector
- Parallel vectors
- Collinearity
- Proportional division of a line
- Ratio theorem
- Vector methods in geometry.

## Vectors in 3 dimensions:

3 dimensional vectors can be represented on a set of 3 axes at right angles to each other (orthogonal), as shown in the diagram.

Note that the z axis is the vertical axis.

To get from A to B you would move:

- 4 units in the x-direction, (x-component)
- 3 units in the y-direction, (y-component)
- 2 units in the z-direction. (z-component)

In component form:  $\overline{AB} = \begin{pmatrix} 4 \\ 3 \\ 2 \end{pmatrix}$

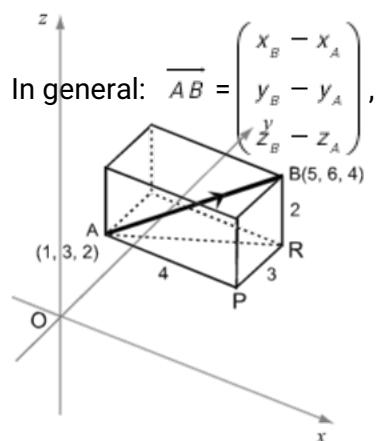

## Column and position vectors

In three dimensions, a displacement is represented by a column vector of the form  $\begin{pmatrix} p \\ q \\ r \end{pmatrix}$  where p, q and r are the changes in x, y, z directions respectively.

### Example

The displacement from A ( 3, 1, 4 ) to B ( 7, 2, 6 ) is represented by the column vector,  $\begin{pmatrix} 7-3 \\ 2-1 \\ 6-4 \end{pmatrix} = \begin{pmatrix} 4 \\ 1 \\ 2 \end{pmatrix}$

The position vector of A written as OA is  $\begin{pmatrix} 3 \\ 1 \\ 4 \end{pmatrix}$  where O is the origin

Addition of vectors in three dimensions is done in the same way as that in two dimensions.

### Example

If  $a = \begin{pmatrix} 3 \\ -2 \\ 5 \end{pmatrix}$  and  $b = \begin{pmatrix} -2 \\ 8 \\ 10 \end{pmatrix}$  then

i.)  $3a + 2b = 3 \begin{pmatrix} 3 \\ -2 \\ 5 \end{pmatrix} + 2 \begin{pmatrix} -2 \\ 8 \\ 10 \end{pmatrix} = \begin{pmatrix} 9 \\ -6 \\ 15 \end{pmatrix} + \begin{pmatrix} -4 \\ 16 \\ 20 \end{pmatrix} = \begin{pmatrix} 5 \\ 10 \\ 35 \end{pmatrix}$

ii.)  $4a - \frac{1}{2}b = 4 \begin{pmatrix} 3 \\ -2 \\ 5 \end{pmatrix} - \frac{1}{2} \begin{pmatrix} -2 \\ 8 \\ 10 \end{pmatrix} = \begin{pmatrix} 12 \\ -8 \\ 20 \end{pmatrix} + \begin{pmatrix} 1 \\ -4 \\ -5 \end{pmatrix} = \begin{pmatrix} 13 \\ -12 \\ 15 \end{pmatrix}$

### Column Vectors in terms of unit Vectors

In three dimension the unit vector in the x axis direction is  $\begin{pmatrix} 1 \\ 0 \\ 0 \end{pmatrix}$ , that in the direction of the y axis is  $\begin{pmatrix} 0 \\ 1 \\ 0 \end{pmatrix}$  while that in the direction of z - axis is  $\begin{pmatrix} 0 \\ 0 \\ 1 \end{pmatrix}$ .

Diagrammatic representation of the vectors.

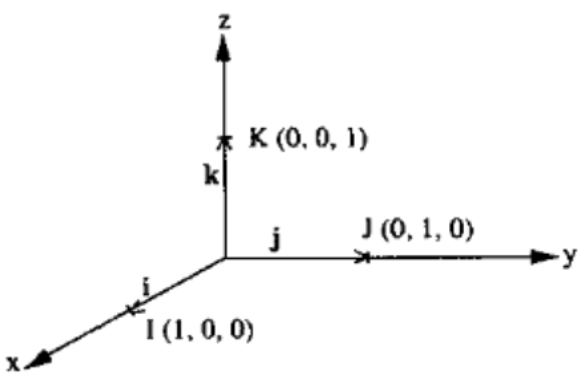

Three unit vectors are written as ;  $i = \begin{pmatrix} 1 \\ 0 \\ 0 \end{pmatrix}$ ,  $j = \begin{pmatrix} 0 \\ 1 \\ 0 \end{pmatrix}$  and  $k = \begin{pmatrix} 0 \\ 0 \\ 1 \end{pmatrix}$

Express vector  $\begin{pmatrix} 5 \\ -2 \\ 7 \end{pmatrix}$  in terms of the unit vector I , j and k

**Solution**

$$\begin{aligned} \begin{pmatrix} 5 \\ -2 \\ 7 \end{pmatrix} &= \begin{pmatrix} 5 \\ 0 \\ 0 \end{pmatrix} + \begin{pmatrix} 0 \\ -2 \\ 0 \end{pmatrix} + \begin{pmatrix} 0 \\ 0 \\ 7 \end{pmatrix} \\ &= 5 \begin{pmatrix} 1 \\ 0 \\ 0 \end{pmatrix} - 2 \begin{pmatrix} 0 \\ 1 \\ 0 \end{pmatrix} + 7 \begin{pmatrix} 0 \\ 0 \\ 1 \end{pmatrix} \\ &= 5i - 2j + 7k \end{aligned}$$

**Note;**

The column vector  $\begin{pmatrix} a \\ b \\ c \end{pmatrix}$  can be expressed as  $a i + b j + c k$

## Magnitude of a 3 dimensional vector.

Given the vector  $AB = xi + yj + 2k$ , then the magnitude of AB is written as  $|AB| = \sqrt{x^2 + y^2 + z^2}$

$$|u| = \sqrt{(x_B - x_A)^2 + (y_B - y_A)^2 + (z_B - z_A)^2}$$

This is the length of the vector.

Use Pythagoras' Theorem in 3 dimensions.

$$AB^2 = AR^2 + BR^2$$

$$= (AP^2 + PR^2) + BR^2$$

$$= (x_B - x_A)^2 + (y_B - y_A)^2 + (z_B - z_A)^2$$

and if  $u = \overline{AB}$  then the magnitude of  $u$ ,  $|u|$  = length of AB

## Distance formula for 3 dimensions

Recall that since:  $\overline{AB} = \begin{pmatrix} x_B - x_A \\ y_B - y_A \\ z_B - z_A \end{pmatrix}$ , then if  $u = \begin{pmatrix} x \\ y \\ z \end{pmatrix}$  then  $|u| = \sqrt{x^2 + y^2 + z^2}$

Since  $x = x_B - x_A$  and  $y = y_B - y_A$  and  $z = z_B - z_A$

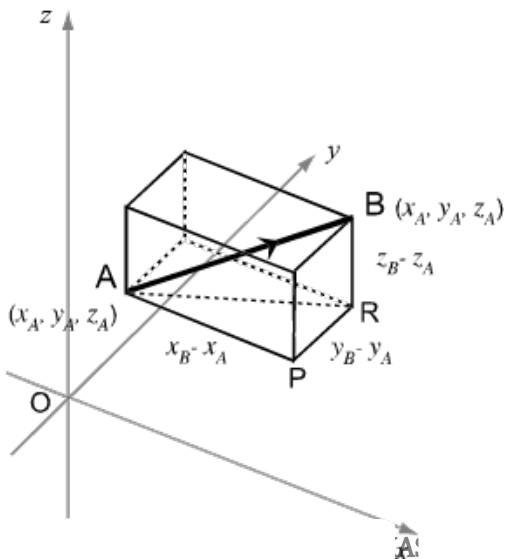

**Example:**

1. If A is (1, 3, 2) and B is (5, 6, 4)

Find  $|\overline{AB}|$

2. If  $u = \begin{pmatrix} 3 \\ -2 \\ 2 \end{pmatrix}$  Find  $|u|$

**Solution**

a.)  $|\overline{AB}| = \sqrt{(5-1)^2 + (6-3)^2 + (4-2)^2} = \sqrt{4^2 + 3^2 + 2^2} = \sqrt{29}$

b.)  $|u| = \sqrt{(3)^2 + (-2)^2 + (2)^2} = \sqrt{9+4+4} = \sqrt{17}$

**Parallel vectors and collinearity**

**Parallel vectors**

Two vectors are parallel if one is scalar multiple of the other. i.e vector a is a scalar multiple of b, i.e .

$a = kb$  then the two vectors are parallel.

**Note;**

Scalar multiplication is simply multiplication of a regular number by an entry in the vector

**Multiplying by a scalar**

A vector can be multiplied by a number (scalar). e.g. multiply **a** by 3 is written as  $3a$ . Vector  $3a$  has three times the length but is in the **same** direction as **a**. In column form, each component will be multiplied by 3.

We can also take a common factor out of a vector in component form. If a vector is a scalar multiple of another vector, then the two vectors are parallel, and differ only in magnitude. This is a useful test to see if lines are parallel.

Example if

$$v = \begin{pmatrix} 12 \\ 16 \\ 20 \end{pmatrix} \Rightarrow v = 4 \begin{pmatrix} 3 \\ 4 \\ 5 \end{pmatrix} \quad a = \begin{pmatrix} 2 \\ 1 \\ -3 \end{pmatrix} \text{ then } 3a = \begin{pmatrix} 6 \\ 3 \\ -9 \end{pmatrix}$$

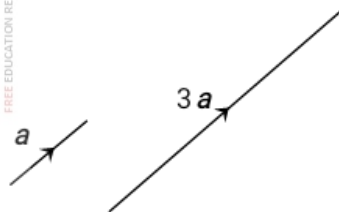

### Collinear Points

Points are collinear if one straight line passes through all the points. For three points A, B, C - if the line AB is parallel to BC, since B is common to both lines, A, B and C are collinear.

### Test for collinearity

#### Example

A is (0, 1, 2), B is (1, 3, -1) and C is (3, 7, -7) Show that A, B and C are collinear.

$$\overline{AB} = \begin{pmatrix} 1 \\ 2 \\ -3 \end{pmatrix} \quad \overline{BC} = \begin{pmatrix} 2 \\ 4 \\ -6 \end{pmatrix} \quad \text{and} \quad \overline{BC} = 2 \begin{pmatrix} 1 \\ 2 \\ -3 \end{pmatrix} = 2\overline{AB}$$

$\overline{AB}$  and  $\overline{BC}$  are scalar multiples, so AB is parallel to BC. Since B is a **common** point, then A, B and C are collinear.

In general the test of collinearity of three points consists of two parts

- Showing that the column vectors between any two of the points are parallel
- Showing that they have a point in common.

#### Example

A (0,3), B (1,5) and C ( 4,11) are three given points. Show that they are collinear.

#### Solution

AB and BC are parallel if  $AB = kBC$ , where k is a scalar

$$AB = \begin{pmatrix} 1 \\ 5 \end{pmatrix} - \begin{pmatrix} 0 \\ 3 \end{pmatrix} = \begin{pmatrix} 1 \\ 2 \end{pmatrix} \quad BC = \begin{pmatrix} 4 \\ 11 \end{pmatrix} - \begin{pmatrix} 1 \\ 5 \end{pmatrix} = \begin{pmatrix} 3 \\ 6 \end{pmatrix}$$

Therefore  $AB \parallel BC$  and point B (1,5) is common. Therefore A,B,and C are collinear.

#### Example

Show that the points A (1,3,5), B( 4,12,20) and C are collinear.

#### Solution

Consider vectors AB and AC

$$AB = \begin{pmatrix} 4 \\ 12 \\ 20 \end{pmatrix} - \begin{pmatrix} 1 \\ 13 \\ 5 \end{pmatrix} = \begin{pmatrix} 3 \\ 9 \\ 15 \end{pmatrix}$$

$$AC = \begin{pmatrix} 3 \\ 9 \\ 15 \end{pmatrix} - \begin{pmatrix} 1 \\ 3 \\ 10 \end{pmatrix} = \begin{pmatrix} 2 \\ 6 \\ 10 \end{pmatrix}$$

$$\begin{pmatrix} 2 \\ 6 \\ 10 \end{pmatrix} = k \begin{pmatrix} 3 \\ 9 \\ 15 \end{pmatrix}$$

Hence  $k = \frac{2}{3}$

$$AC = \frac{2}{3}AB$$

Therefore  $AB \parallel AC$  and the two vectors share a common point A. The three points are thus collinear.

**Example**

In the figure above  $OA = a$   $OB = b$  and  $OC = 3OB$

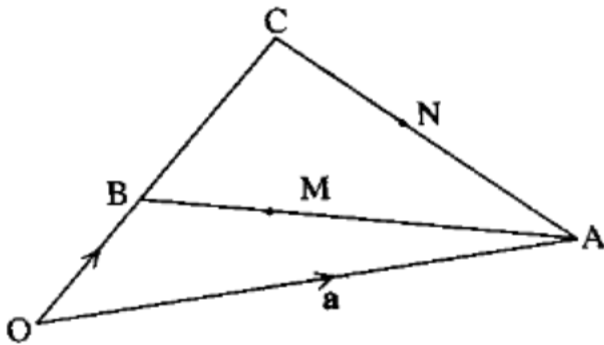

- Express AB and AC in terms of a and b
- Given that  $AM = \frac{3}{4} AB$  and  $AN = \frac{1}{2} AC$ , Express OM and ON in terms of a and b
- Hence, show that OM and ON are collinear

**Solution**

- $$AB = OA + OB$$

$$= -a + b$$

$$AC = -a + 3b$$

$$\begin{aligned}
 \text{b.) } OM &= OA + AM \\
 &= OA + \frac{3}{4}AB \\
 &= a + \frac{3}{4}(-a + b) \\
 &= a - \frac{3}{4}a + \frac{3}{4}b \\
 &= \frac{1}{4}a + \frac{3}{4}b
 \end{aligned}$$

$$\begin{aligned}
 ON &= OA + AN \\
 &= OA + \frac{1}{2} AC
 \end{aligned}$$

$$a + \frac{1}{2}(-a + 3b)$$

$$\begin{aligned}
 a &= a - \frac{1}{2}a + \frac{3}{2}b \\
 &= \frac{1}{2}a + \frac{3}{2}b
 \end{aligned}$$

a

$$\text{c.) } OM = kON \quad \frac{3}{4}b + \frac{1}{4}a = \frac{k}{2}a + \frac{3k}{2}b$$

Comparing the coefficients of a;

$$\frac{1}{4} = \frac{k}{2}$$

$$k = \frac{1}{2}$$

Thus,  $OM = \frac{1}{2}ON$ .

Thus two vectors also share a common point ,O .Hence, the points are collinear.

### Proportional Division of a line

In the figure below, the line is divided into 7 equal parts

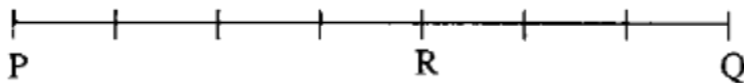

The point R lies  $\frac{4}{7}$  of the ways along PQ if we take the direction from P to Q to be positive, we say R



divides PQ internally in the ratio 4 : 3..

If Q to P is taken as positive, then R divides QP internally in the ratio 3 : 4 .Hence, QR : RP = 3 : 4 or ,4 QR = 3RP.

### External Division

In internal division we look at the point within a given interval while in external division we look at points outside a given interval,

In the figure below point P is produced on AB



The line AB is divided into three equal parts with BP equal to two of these parts. If the direction from A to B is taken as positive, then the direction from P to B is negative.

Thus AP : PB = 5 : -2. In this case we say that P divides AB externally in the ratio 5 : -2 or P divides AB in the ratio 5 : -2.

### Points, Ratios and Lines

**Find the ratio in which a point divides a line.**

**Example:**

The points A(2, -3, 4), B(8, 3, 1) and C(12, 7, -1) form a straight line. Find the ratio in which B divides AC. Solution

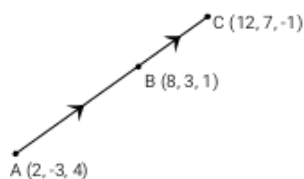

$$\overline{AB} = b - a = \begin{pmatrix} 8-2 \\ 3-(-3) \\ 1-4 \end{pmatrix} = \begin{pmatrix} 6 \\ 6 \\ -3 \end{pmatrix}$$

$$\overline{BC} = c - b = \begin{pmatrix} 12-8 \\ 7-3 \\ -1-1 \end{pmatrix} = \begin{pmatrix} 4 \\ 4 \\ -2 \end{pmatrix}$$

$$\overline{AB} = 3 \begin{pmatrix} 2 \\ 2 \\ -1 \end{pmatrix} \text{ and } \overline{BC} = 2 \begin{pmatrix} 2 \\ 2 \\ -1 \end{pmatrix} \text{ So, } \frac{\overline{AB}}{\overline{BC}} = \frac{3}{2} \text{ or } AB : BC = 3 : 2$$

B divides AC in ratio of 3 : 2

### Points dividing lines in given ratios.

**Example:**

P divides AB in the ratio 4:3. If A is (2, 1, -3) and B is (16, 15, 11), find the co-ordinates of P.

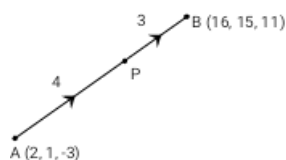

**Solution:**

$$\frac{\overline{AP}}{\overline{PB}} = \frac{4}{3} \quad \text{so} \quad 3\overline{AP} = 4\overline{PB}$$

$$\therefore 3(\mathbf{p} - \mathbf{a}) = 4(\mathbf{b} - \mathbf{p})$$

$$3\mathbf{p} - 3\mathbf{a} = 4\mathbf{b} - 4\mathbf{p}$$

$$7\mathbf{p} = 4\mathbf{b} + 3\mathbf{a}$$

$$\mathbf{p} = \frac{1}{7}(4\mathbf{b} + 3\mathbf{a})$$

$$\mathbf{p} = \frac{1}{7} \left( 4 \begin{pmatrix} 16 \\ 15 \\ 11 \end{pmatrix} + 3 \begin{pmatrix} 2 \\ 1 \\ -3 \end{pmatrix} \right) = \frac{1}{7} \left( \begin{pmatrix} 64 \\ 60 \\ 44 \end{pmatrix} + \begin{pmatrix} 6 \\ 3 \\ -9 \end{pmatrix} \right) = \frac{1}{7} \begin{pmatrix} 70 \\ 63 \\ 35 \end{pmatrix} = \begin{pmatrix} 10 \\ 9 \\ 5 \end{pmatrix}$$

### Points dividing lines in given ratios externally.

**Example:**

Q divides MN externally in the ratio of 3:2. M is (-3, -2, -1) and N is (0, -5, 2). Find the co-ordinates of Q.

**Note** that QN is shown as -2 because the two line segments are MQ and QN, and QN is in the opposite direction to MQ.

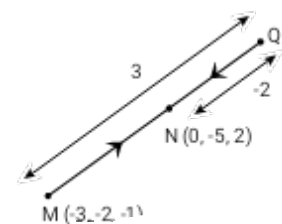

$$\frac{\overline{MQ}}{\overline{QN}} = \frac{3}{-2} \quad \text{so} \quad -2\overline{MQ} = 3\overline{QN}$$

$$\therefore -2(\mathbf{q} - \mathbf{m}) = 3(\mathbf{n} - \mathbf{q})$$

$$-2\mathbf{q} + 2\mathbf{m} = 3\mathbf{n} - 3\mathbf{q}$$

$$q = 3n - 2m$$

$$q = 3 \begin{pmatrix} 0 \\ -5 \\ 2 \end{pmatrix} - 2 \begin{pmatrix} -3 \\ -2 \\ -1 \end{pmatrix} = \begin{pmatrix} 0 \\ -15 \\ 6 \end{pmatrix} - \begin{pmatrix} -6 \\ -4 \\ -2 \end{pmatrix} = \begin{pmatrix} 6 \\ -11 \\ 8 \end{pmatrix}$$

P is P(10, 9, 5)

### The Ration Theorem

The figure below shows a point S which divides a line AB in the ratio m : n

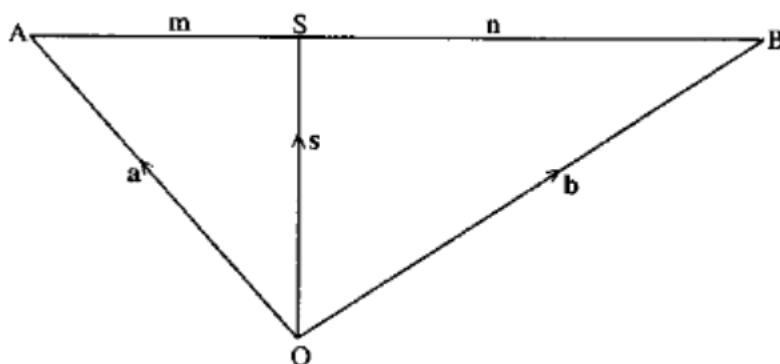

Taking any point O as origin, we can express s in terms of a and b the position vectors of a and b respectively.

$$OS = OA + AS$$

$$\text{But } AS = \frac{m}{m+n} AB$$

$$\text{Therefore, } OS = OA + \frac{m}{m+n} AB$$

$$\text{Thus } S = a + \frac{m}{m+n} (-a + b)$$

$$= a - \frac{m}{m+n} a + \frac{m}{m+n} b$$

$$= \left(1 - \frac{m}{m+n}\right)a + \frac{m}{m+n}b$$

$$= \left(\frac{m+n-m}{m+n}\right)a + \frac{m}{m+n}b$$

$$= \frac{n}{m+n}a + \frac{m}{m+n}b$$

This is called the ratio theorem. The theorem states that the position vectors  $s$  of a point which divides a line  $AB$  in the ratio  $m : n$  is given by the formula;

$S = \frac{n}{m+n}a + \frac{m}{m+n}b$ , where  $a$  and  $b$  are position vectors of  $A$  and  $B$  respectively. Note that the sum of co-ordinates  $\frac{n}{m+n}$  and  $\frac{m}{m+n} = 1$

Thus, in the above example if the ratio  $m : n = 5 : 3$

Then  $m = 5$  and  $n = 3$

$$OR = \frac{3}{5+3}a + \frac{5}{5+3}b$$

$$\text{Thus, } r = \frac{3}{8}a + \frac{5}{8}b$$

### Example

A point  $R$  divides a line  $QR$  externally in the ratio  $7 : 3$ . If  $q$  and  $r$  are position vectors of point  $Q$  and  $R$  respectively, find the position vector of  $p$  in terms of  $q$  and  $r$ .

### Solution

We take any point  $O$  as the origin and join it to the points  $Q$ ,  $R$  and  $P$  as shown below

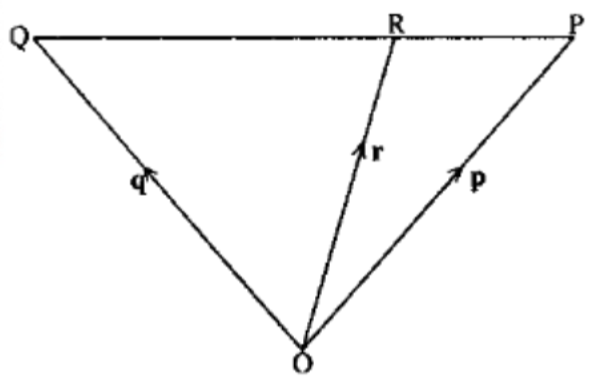

QP: PR = 7: -3

Substituting m =7 and n = -3 in the general formulae;

$$OP = \frac{-3}{7+(-3)}q + \frac{7}{7+(-3)}r$$

$$P = \frac{-3}{4}q + \frac{7}{4}r$$

Vectors can be used to determine the ratio in which a point divides two lines if they intersect

**Example**

In the below OA = a and OB = B. A point P divides OA in the ratio 3:1 and another point Q divides AB in the ratio 2 : 5 .If OQ meets BP at M Determine:

- a.) OM : MQ
- b.) BM : MP

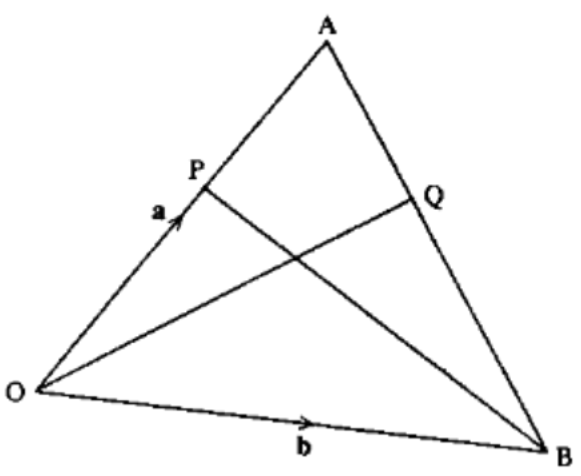

Let OM : MQ = k : ( 1 - k) and BM -MP = n : ( 1 - n)  
Using the ratio theorem

$$OQ = \frac{5}{7}a + \frac{2}{7}b$$

$$OM = kOQ$$

$$= k\left(\frac{5}{7}a + \frac{2}{7}b\right)$$

Also by ratio theorem;  
 $OM = n OP + (1 - n) OB$

But  $OP = \frac{3}{4}a$

Therefore,  $OM = n\left(\frac{3}{4}a\right) + (1-n)b$

Equating the two expressions;

$$k\left(\frac{5}{7}a + \frac{2}{7}b\right) = n\left(\frac{3}{4}a\right) + (1-n)b$$

Comparing the co-efficients

$$\frac{5}{7}k = \frac{3}{4}n \dots\dots\dots 1$$

$$\frac{2}{7}k = 1 - n \dots\dots\dots 2$$

$$k = \frac{21}{25} \text{ and } n = \frac{10}{13}$$

$$\text{The ratio } BM : MP = \frac{10}{13} : \frac{3}{13}$$

$$= 10 : 3$$

End of topic

Did you understand everything?

If not ask a teacher, friends or anybody and make sure you understand before going to sleep!

### Past KCSE Questions on the topic

- The figure below is a right pyramid with a rectangular base ABCD and VO as the height. The vectors  $AD = a$ ,  $AB = b$  and  $DV = v$

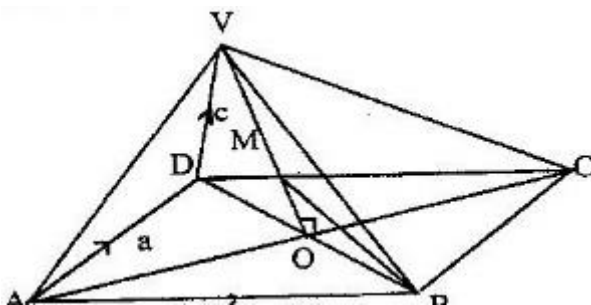

- a) Express
- (i)  $AV$  in terms of  $a$  and  $c$
  - (ii)  $BV$  in terms of  $a$ ,  $b$  and  $c$
- (b)  $M$  is point on  $OV$  such that  $OM: MV=3:4$ , Express  $BM$  in terms of  $a$ ,  $b$  and  $c$ .  
Simplify your answer as far as possible

2. In triangle  $OAB$ ,  $OA = a$   $OB = b$  and  $P$  lies on  $AB$  such that  $AP: BP = 3:5$

(b) Find the terms of  $a$  and  $b$  the vectors

- (i)  $AB$
- (ii)  $AP$
- (iii)  $BP$
- (iv)  $OP$

(c) Point  $Q$  is on  $OP$  such  $AQ = \frac{-5}{8a} + \frac{9}{40b}$

Find the ratio  $OQ: QP$

3. The figure below shows triangle  $OAB$  in which  $M$  divides  $OA$  in the ratio  $2: 3$  and  $N$  divides  $OB$  in the ratio  $4:1$   $AN$  and  $BM$  intersect at  $X$

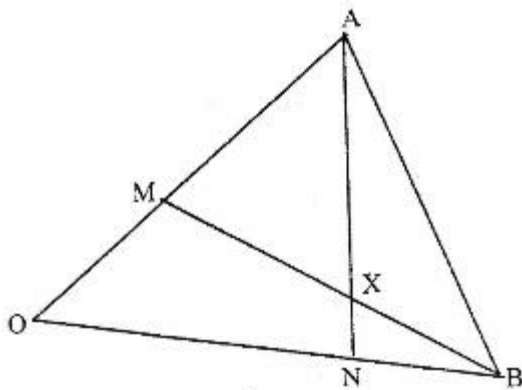

- (a) Given that  $OA = a$  and  $OB = b$ , express in terms of  $a$  and  $b$ :
- $AN$
  - $BM$
- (b) If  $AX = s AN$  and  $BX = tBM$ , where  $s$  and  $t$  are constants, write two expressions for  $OX$  in terms of  $a, b, s$  and  $t$

Find the value of  $s$

Hence write  $OX$  in terms of  $a$  and  $b$

4. The position vectors for points  $P$  and  $Q$  are  $4i + 3j + 6k$  respectively. Express vector  $PQ$  in terms of unit vectors  $i, j$  and  $k$ . Hence find the length of  $PQ$ , leaving your answer in simplified surd form.
5. In the figure below, vector  $OP = p$  and  $OR = r$ . Vector  $OS = 2r$  and  $OQ = \frac{3}{2}p$ .

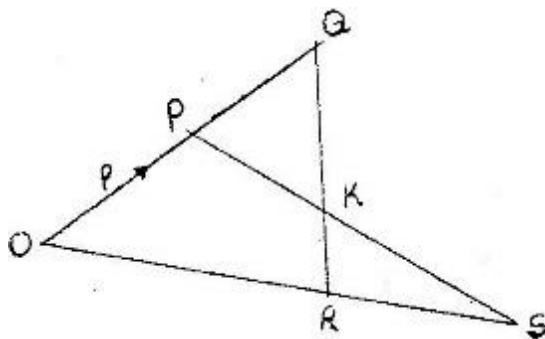

- Express in terms of  $p$  and  $r$  (i)  $QR$  and (ii)  $PS$
  - The lines  $QR$  and  $PS$  intersect at  $K$  such that  $QK = m QR$  and  $PK = n PS$ , where  $m$  and  $n$  are scalars. Find two distinct expressions for  $OK$  in terms of  $p, r, m$  and  $n$ . Hence find the values of  $m$  and  $n$ .
  - State the ratio  $PK:KS$
6. Point  $T$  is the midpoint of a straight line  $AB$ . Given the position vectors of  $A$  and  $T$  are  $i - j + k$  and  $2i + \frac{1}{2}k$  respectively, find the position vector of  $B$  in terms of  $i, j$  and  $k$



7. A point R divides a line PQ internally in the ratio 3:4. Another point S, divides the line PR externally in the ratio 5:2. Given that PQ = 8 cm, calculate the length of RS, correct to 2 decimal places.
8. The points P, Q, R and S have position vectors  $2p$ ,  $3p$ ,  $r$  and  $3r$  respectively, relative to an origin O. A point T divides PS internally in the ratio 1:6
- (a) Find, in the simplest form, the vectors OT and QT in terms p and r
- (b) (i) Show that the points Q, T, and R lie on a straight line  
(ii) Determine the ratio in which T divides QR
9. Two points P and Q have coordinates (-2, 3) and (1, 3) respectively. A translation map point P to P' (10, 10)
- (b) Find the coordinates of Q' the image of Q under the translation
- (c) The position vector of P and Q in (a) above are p and q respectively given that  $mp - nq = -12$

$$\begin{pmatrix} 9 \\ 9 \end{pmatrix}$$

Find the value of m and n

10. Given that  $q\mathbf{i} + \frac{1}{3}j + \frac{2}{3}k$  is a unit vector, find q
11. In the diagram below, the coordinates of points A and B are (1, 6) and (15, 6) respectively). Point N is on OB such that  $3\text{ON} = 2\text{OB}$ . Line OA is produced to L such that  $\text{OL} = 3\text{OA}$

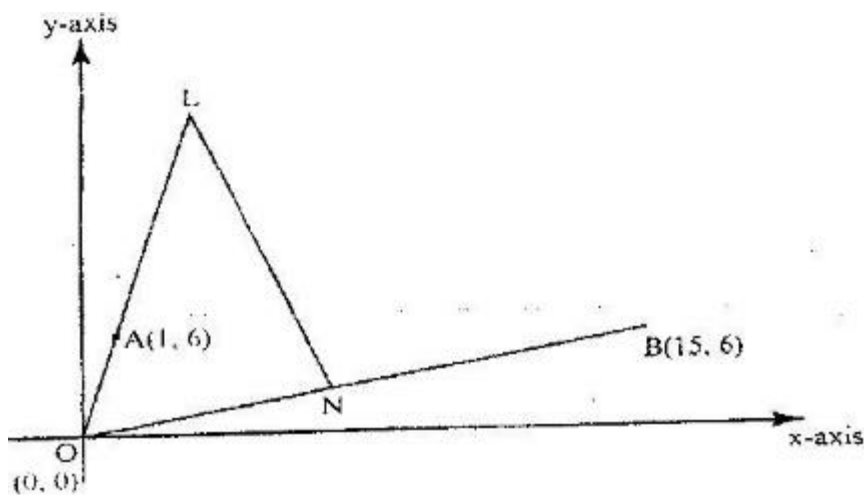

- (a) Find vector LN
- (b) Given that a point M is on LN such that LM: MN = 3: 4, find the coordinates of M
- (c) If line OM is produced to T such that OM: MT = 6:1
- (i) Find the position vector of T
- (ii) Show that points L, T and B are collinear

12. In the figure below,  $OQ = q$  and  $OR = r$ . Point  $X$  divides  $OQ$  in the ratio 1: 2 and  $Y$  divides  $OR$  in the ratio 3: 4 lines  $XR$  and  $YQ$  intersect at  $E$ .

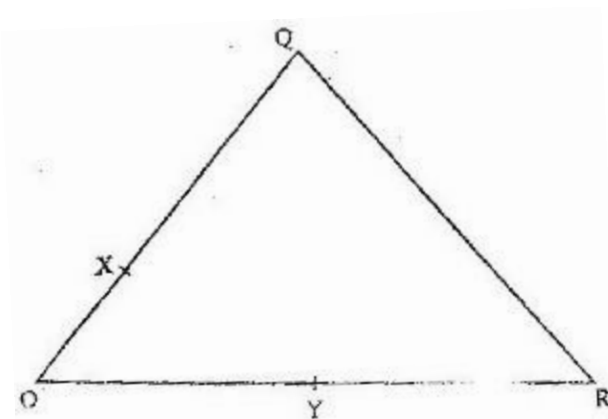

- (a) Express in terms of  $q$  and  $r$
- $XR$
  - $YQ$
- (b) If  $XE = m XR$  and  $YE = n YQ$ , express  $OE$  in terms of:
- $r, q$  and  $m$
  - $r, q$  and  $n$
- (c) Using the results in (b) above, find the values of  $m$  and  $n$ .

13. Vector  $q$  has a magnitude of 7 and is parallel to vector  $p$ . Given that  $p = 3i - j + 1\frac{1}{2}k$ , express vector  $q$  in terms of  $i, j$ , and  $k$ .

14. In the figure below,  $OA = 3i + 3j$   $ABD$   $OB = 8i - j$ .  $C$  is a point on  $AB$  such that  $AC:CB = 3:2$ , and  $D$  is a point such that  $OB \parallel CD$  and  $2OB = CD$  (T17)

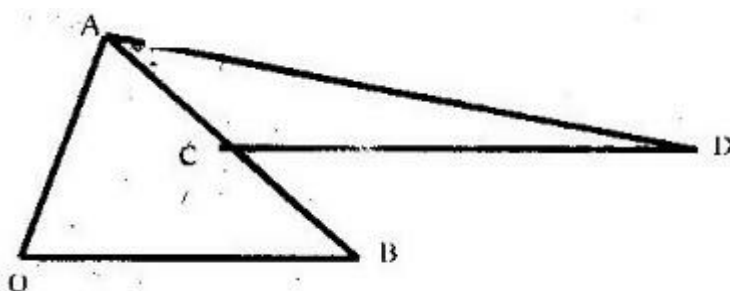

Determine the vector  $DA$  in terms of  $i$  and  $j$

15. In the figure below,  $KLMN$  is a trapezium in which  $KL$  is parallel to  $NM$  and  $KL = 3NM$

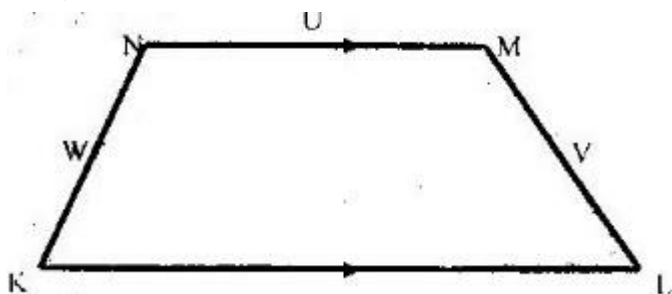

Given that  $KN = w$ ,  $NM = u$  and  $ML = v$ . Show that  $2u = v + w$

16. The points P, Q and R lie on a straight line. The position vectors of P and R are  $2i + 3j + 13k$  and  $5i - 3j + 4k$  respectively; Q divides SR internally in the ratio 2: 1. Find the

- (a) Position vector of Q  
(b) Distance of Q from the origin

17. Co-ordinates of points O, P, Q and R are (0, 0), (3, 4), (11, 6) and (8, 2) respectively. A point T is such that the vector  $OT$ ,  $QP$  and  $QR$  satisfy the vector equation  $OT = QP + \frac{1}{2} QT$ . Find the coordinates of T.

18. In the figure below  $OA = a$ ,  $OB = b$ ,  $AB = BC$  and  $OB: BD = 3:1$

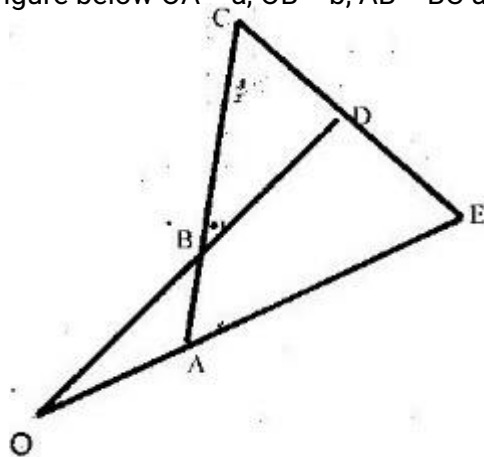

- (a) Determine  
(i)  $AB$  in terms of  $a$  and  $b$   
(ii)  $CD$ , in terms of  $a$  and  $b$
- (b) If  $CD: DE = 1:k$  and  $OA: AE = 1:m$  determine  
(i)  $DE$  in terms of  $a$ ,  $b$  and  $k$   
(ii) The values of  $k$  and  $m$

19. The figure below shows a grid of equally spaced parallel lines

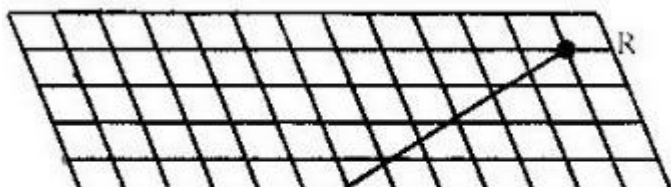

$\vec{AB} = a$  and  $\vec{BC} = b$

(a) Express

(i)  $\vec{AC}$  in terms of  $a$  and  $b$

(ii)  $AD$  in terms of  $a$  and  $b$

(b) Using triangle  $BEP$ , express  $BP$  in terms of  $a$  and  $b$

(c)  $PR$  produced meets  $BA$  produced at  $X$  and  $PR = \frac{1}{9}b - \frac{8}{3}a$

By writing  $PX$  as  $kPR$  and  $BX$  as  $hBA$  and using the triangle  $BPX$  determine the ratio  $PR:RX$

20. The position vectors of points  $x$  and  $y$  are  $x = 2i + j - 3k$  and  $y = 3i + 2j - 2k$  respectively. Find  $XY$

2. Given that  $X = 2i + j - 2k$ ,  $y = -3i + 4j - k$  and  $z = 5i + 3j + 2k$  and that  $p = 3x - y + 2z$ , find the magnitude of vector  $p$  to 3 significant figures.

**0714497530**