

PHYSICS FORM ONE

CHAPTER ONE

INTRODUCTION TO PHYSICS

Science in our lives

Scientists are people trained in science and who practice the knowledge of science. We require people in industries to work as engineers, technicians, researchers, in hospitals as doctors, nurses and technologists. Science gives us powerful ideas, instruments and methods which affect us in our daily lives.

Scientific methods

1. A **laboratory** is a building specifically designed for scientific work and may contain many pieces of apparatus and materials for use.
2. A **hypothesis** is a scientific fact or statement that has not been proven or experimented.
3. A **law or principle** is a scientific fact or statement that has been proven and experimented to be true for all conditions.
4. A **theorem** is a fact or statement that is true and proven but applicable under specific conditions.

What is physics?

Physics is a Greek word meaning **nature** hence it deals with **natural phenomena**. **Physics is therefore a science whose objective is the study of components of matter and their mutual interactions. Physics is also defined as the study of matter and its relation to energy.** A physicist is able to explain bulk properties of matter as well as other phenomena observed.

Branches of physics

1. **Mechanics** – the study of motion of bodies under the influence of force.
2. **Electricity** – this deals with the movement of charge from one point to another through a conductor.
3. **Magnetism** – the study of magnets and magnetic fields and their extensive applications.
4. **Thermodynamics / heat** – this is the study of the transformation of heat from one form to another.
5. **Optics** – the study of light as it travels from one media to another
6. **Waves** – the study of disturbances which travel through mediums or a vacuum.
7. **Particle physics**
8. **Nuclear physics**
9. **Plasma physics**

Relation of physics to other subjects

Since physics enables us to understand basic components of matter and their mutual interactions it forms the base of natural science. Biology and chemistry borrow from physics in explaining processes occurring in living things and organisms. Physics also provides

techniques which are applied almost every area of pure and applied science i.e. meteorology, astronomy etc.

Career opportunities in physics

1. **Engineering** – *civil*

- *Electrical*
- *Mechanical*
- *Agricultural*
- *Environmental*
- *Chemical*
- *Computer*

2. **Meteorology**

3. **Surveying**

4. **Geology**

5. **Astronomy**

NOTE: - *all science based careers i.e. doctors, nurses, technologists, engineers, pharmacists etc. need physics as a true foundation.*

Basic laboratory safety rules

1. Proper dressing must be observed, no loose clothing, hair and closed shoes must be worn.
2. Identify the location of electricity switches, fire-fighting equipment, first aid kit, gas and water supply systems.
3. Keep all windows open whenever working in the laboratory.
4. Follow all instructions carefully and never attempt anything in doubt.
5. No eating or drinking allowed in the laboratory.
6. Ensure that all electrical switches, gas and water taps are turned off when not in use.
7. Keep floors and working surfaces dry. Any spillage must be wiped off immediately.
8. All apparatus must be cleaned and returned in the correct location of storage after use.
9. Hands must be washed before leaving the laboratory.
10. Any accidents must be reported to the teacher immediately.

CHAPTER TWO

MEASUREMENT I

In order to measure we need to know or define the quantity to be measured and the units for measuring it. In **1971** a system known as the **International System of Units** (*Systeme' Internationale*) and seven basic units were agreed upon as follows. Other quantities can be obtained from these basic quantities and are referred to as **derived quantities**.

Basic quantity	SI units	Symbols
Length	Metre	m
Mass	Kilogram	kg
Time	Second	s
Electric current	Ampere	A
Thermodynamic temperature	Kelvin	K
Luminous intensity	Candela	Cd
Amount of substance	Mole	mol

Length

This is the measure of distance between two points in space. The SI unit for length is the **metre (m)**. Therefore $1 \text{ km} = 1000 \text{ m}$

$$1 \text{ Hm} = 100 \text{ m}$$

$$1 \text{ Dm} = 10 \text{ m}$$

$$1 \text{ mm} = 0.001 \text{ m}$$

Length is measured using a **metre rule** (100 cm), **tape measure** (100 m, 300 m, 500 m)

Area

This is the measure of the extent of a surface. It is a derived quantity of length. Its SI units are square metres (m^2). Other units are cm^2 , km^2 , etc. Formulas are used to determine areas of regular bodies while for irregular bodies an approximation of area is used.

Volume

This is the amount of space occupied by matter. The SI units for volume is cubic metre (m^3). Other sub-multiples are cm^3 , mm^3 and *l*. Hence $1 \text{ m}^3 = 1,000,000 \text{ cm}^3$ and $1 \text{ l} = 1,000 \text{ cm}^3$. Volume can be measured using a measuring cylinder, eureka can, pipette, burette, volumetric flask, beaker, etc.

Mass

This is the quantity of matter contained in a substance. Matter is anything that occupies space and has weight. The SI unit for mass is the Kilogram (**kg**). Other sub-multiples used are

grams (g), milligrams (mg) and tonnes (t). **1 kg = 1,000 g = 1,000,000 mg = 100 tonnes.** A beam balance is used to measure mass.

Density

This is mass per unit volume of a substance. It is symbolized by rho (ρ) and its SI units are kg/m^3 . **Density = mass / volume.**

Examples

1. A block of glass of mass 187.5 g is 5.0 cm long, 2.0 cm thick and 7.5 cm high. Calculate the density of the glass in kgm^{-3} .

Solution

$$\text{Density} = \text{mass} / \text{volume} = (187.5 / 1000) / (2.0 \times 7.5 \times 5.0 / 1,000,000) = 2,500 \text{ kgm}^{-3}.$$

2. The density of concentrated sulphuric acid is 1.8 g/cm^3 . Calculate the volume of 3.1 kg of the acid.

Solution

$$\text{Volume} = \text{mass} / \text{density} = 3,100 / 1.8 = 1,722 \text{ cm}^3 \text{ or } 0.001722 \text{ m}^3.$$

The following is a list of densities of some common substances

Substance	Density (g/cm^3)	Density (kg/m^3)
Platinum	21.4	21,400
Gold	19.3	19,300
Lead	11.3	11,300
Silver	10.5	10,500
Copper	8.93	8,930
Iron	7.86	7,860
Aluminium	2.7	2,700
Glass	2.5	2,500
Ice	0.92	920
Mercury	13.6	13,600
Sea water	1.03	1,030
Water	1.0	1,000
Kerosene	0.80	800
Alcohol	0.79	790
Carbon (iv) oxide	0.00197	1.97
Air	0.00131	1.31
Hydrogen	0.000089	0.089

Example

The mass of an empty density bottle is 20 g. Its mass when filled with water is 40.0 g and

50.0 g when filled with liquid X. Calculate the density of liquid X if the density of water is 1,000 kgm⁻³.

Solution

Mass of water = 40 – 20 = 20 g = 0.02 kg.

Volume of water = 0.02 / 1,000 = 0.00002 m³. Volume of liquid = volume of bottle

Mass of liquid = 50 – 20 = 30 g = 0.03 kg

Therefore density of liquid = 0.03 / 0.00002 = 1,500 kgm⁻³

Relative density

This is the density of a substance compared to the density of water.

It is symbolized by **(d)** and has no units since it's a ratio.

Relative density (d) = density of substance / density of water. It

is measured using a relative density bottle

Example

The relative density of some type of wood is 0.8. Find the density of the wood in kg/m³.

Solution

Density of substance = d × density of water

Density of substance = 0.8 × 1,000 = 800 kgm⁻³

Densities of mixtures

We use the following formula to calculate densities of mixtures

Density of the mixture = mass of the mixture / volume of the mixture

Example

100 cm³ of fresh water of density 1,000 kgm⁻³ is mixed with 100 cm³ of sea water of density 1030 kgm⁻³. Calculate the density of the mixture.

Solution

Mass = density × volume

Mass of fresh water = 1,000 × 0.0001 = 0.1 kg

Mass of sea water = 1030 × 0.0001 = 0.103 kg

Mass of mixture = 0.1 + 0.103 = 0.203 kg

Volume of mixture = 100 + 100 = 200 cm³ = 0.0002 m³

Therefore density = mass / volume = 0.203 / 0.0002 = 1,015 kg/m³.

Time

This is a measure of duration of an event. The SI unit for time is the second (**s**). Submultiples of the second are milliseconds, microseconds, minute, hour, day, week and year. It is measured using clocks, stop watches, wrist watches, and digital watches.

Accuracy and errors

Accuracy is the closeness of a measurement to the correct value of the quantity being measured. It is expressed as an error. **An error is therefore the deviation of measurement**

to the correct value being measured. The smaller the error the accurate the measurement.
 $\% \text{ error} = (\text{sensitivity} / \text{size measured}) \times 100.$

CHAPTER THREE FORCES.

Force is a push or a pull. Force is therefore that which changes a body's state of motion or shape. The SI unit for force is Newton (N). It is a vector quantity. It is represented by the following symbol.



Types of forces

1. Gravitational force – *this is the force of attraction between two bodies of given masses.*
 - *Earth's gravitational force is the force which pulls a body towards its center. This pull of gravity is called weight.*
2. Force of friction – *this is a force which opposes the relative motion of two surfaces in contact with each other. Friction in fluids is known as viscosity.*
3. Tension force – *this is the pull or compression of a string or spring at both its ends.*
4. Upthrust force – *this is the upward force acting on an object immersed in a fluid.*
5. Cohesive and adhesive forces – *cohesive is the force of attraction of molecules of the same kind while adhesive is the force of attraction of molecules of different kinds.*
6. Magnetic force – *this is a force which causes attraction or repulsion in a magnet.*
7. Electrostatic force – *this is the force of attraction or repulsion of static charges.*
8. Centripetal force – *this is a force which constrains a body to move in a circular orbit or path.*
9. Surface tension – *this is the force which causes the surface of a liquid to behave like a stretched skin. This force is cohesive.*

Factors affecting surface tension

- a) Impurities – they reduce the surface tension of a liquid i.e. addition of detergent
- b) Temperature – rise in temperature reduces tension by weakening inter-molecular forces.

Mass and weight.

Mass is the amount of matter contained in a substance while weight is the pull of gravity on an object. The SI unit for mass is the **Kg** while weight is the **newton (N)**. Mass is constant regardless of place while weight changes with place. The relationship between mass and weight is given by the following formula, **W = mg** where g = gravitational force.

Differences between mass and weight

Mass	Weight
<i>It is the quantity of matter in a body</i>	<i>It is the pull of gravity on a body</i>
<i>It is measured in kilograms</i>	<i>It is measured in newton's</i>
<i>It is the same everywhere</i>	<i>It changes from place to place</i>
<i>It is measured using a beam balance</i>	<i>Measured using a spring balance</i>
<i>Has magnitude only</i>	<i>Has both magnitude and direction</i>

Example

An astronaut weighs 900 N on earth. On the moon he weighs 150 N. Calculate the moons' gravitational strength. (Take g = 10 N/kg).

Solution

$$\begin{aligned} \text{Moons' gravitational strength} &= \text{weight of astronaut on the moon} / \text{mass of astronaut.} \\ &= 150 / 90 = 1.67 \text{ Nkg}^{-1}. \end{aligned}$$

Measuring force

We use a spring balance to measure force. A spring balance is an instrument that uses the extension of a spring to measure forces.

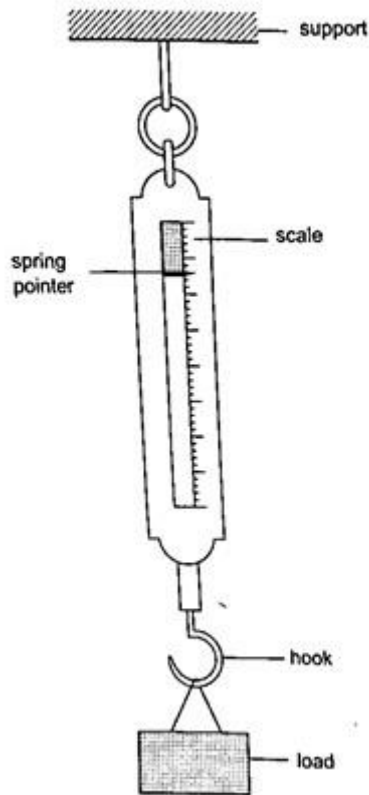

Example

The length of a spring is 16.0 cm. its length becomes 20.0 cm when supporting a weight of 5.0 N. calculate the length of the spring when supporting a weight of:

- a) 2.5 N b) 6.0 N c) 200 N

Solution

5N causes an extension of 4.0 cm, therefore 1.0 cm causes an extension of $4/5 = 0.8$ cm.

- a) 2.5 N $\Rightarrow 2.5 \times 0.8 = 2.0$ cm therefore length becomes = $16.0 + 2.0 = 18.0$ cm.
 b) 6.0 N $\Rightarrow 6.0 \times 0.8 = 4.8$ cm therefore length becomes = $16.0 + 4.8 = 20.8$ cm.
 c) 200 N $\Rightarrow 200 \times 0.8 = 160.0$ cm therefore length becomes = $16.0 + 160.0 = 176.0$ cm.

Vector and scalar quantities

A scalar quantity is a quantity which has magnitude (size) only. Examples are distance, mass, speed

A vector quantity is a quantity which has both magnitude and direction. Examples are displacement, weight, velocity.

CHAPTER FOUR

PRESSURE

Pressure is defined as the force acting normally (perpendicularly) per unit area. The SI units for pressure is **newton per metre squared (N/m^2).** One Nm^{-2} is known as one **Pascal (Pa).**

Pressure = normal force / area or pressure = thrust / area. Another unit for measuring pressure is the **bar**. 1 bar = 10^5 N/m². 1 millibar = 100 N/m². **Calculating pressure**

Examples

1. A rectangular brick of weight 10 N, measures 50 cm × 30 cm × 10 cm. calculate the values of the maximum and minimum pressures which the block exert when resting on a horizontal table.

Solution

Area of the smallest face = $0.3 \times 0.1 = 0.03$ m².

Area of the largest face = $0.5 \times 0.3 = 0.15$ m².

Maximum pressure = $10 \text{ N} / 0.03 = 3.3 \times 10^2$ N/m². Minimum pressure = $10 \text{ N} / 0.15 = 67$ N/m².

2. A man of mass 84 kg stands upright on a floor. If the area of contact of his shoes and the floor is 420 cm², determine the average pressure he exerts on the floor. (Take $g = 10 \text{ N/Kg}$)

Solution

Pressure = force / area = $840 / 0.042 = 20,000$ Nm⁻².

Pressure in liquids.

The following formula is used to determine pressure in liquids.

Pressure = h ρ g, where **h** – height of the liquid, **ρ** – density and **g** – is force of gravity. **Examples**

1. A diver is 10 m below the surface of water in a dam. If the density of water is $1,000 \text{ kgm}^{-3}$, determine the pressure due to the water on the diver. (Take $g = 10 \text{ Nkg}^{-1}$)

Solution

Pressure = $h \rho g = 10 \times 1000 \times 10 = 100,000$ Nm⁻².

2. The density of mercury is $13,600 \text{ kgm}^{-3}$. Determine the liquid pressure at a point 76 cm below the surface of mercury. (Take $g = 10 \text{ Nkg}^{-1}$)

Solution

Pressure = $h \rho g = 0.76 \times 13,600 \times 10 = 103,360$ Nm⁻².

3. The height of the mercury column in a barometer is found to be 67.0 cm at a certain place. What would be the height of a water barometer at the same place? (Densities of mercury and water are $1.36 \times 10^4 \text{ kg/m}^3$ and $1.0 \times 10^3 \text{ kg/m}^3$ respectively.)

Solution

Let the pressure due to water be $h_1 \rho_1 g_1 = h \rho g$, hence;

$h_1 = h \rho / \rho_1 = (6.7 \times 10^{-1}) \times (1.36 \times 10^4) = 911.2$ cm or 9.11 m.

U-tube manometer

It is a transparent tube bent into U-shape. When a liquid is poured into a u-tube it settles at equal level since pressure depends on height and they share the same bottom. Consider the following diagrams;

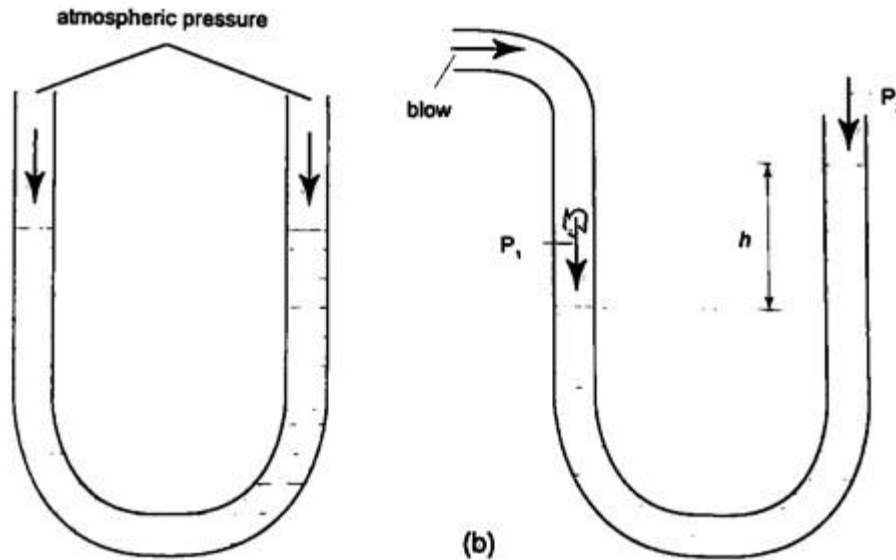

For the levels to differ the pressure P_1 must be greater than P_2 , hence

$$P_1 = P_2 + h\rho g.$$

If P_1 is the lung pressure, P_0 is the atmospheric pressure, then if the difference is ' h ' then lung pressure can be calculated as follows.

$$P_1 = P_0 + h\rho g.$$

Example

A man blows into one end of a U-tube containing water until the levels differ by 40.0 cm. if the atmospheric pressure is $1.01 \times 10^5 \text{ N/m}^2$ and the density of water is 1000 kg/m^3 , calculate his lung pressure.

Solution

Lung pressure = atmospheric Pressure + liquid pressure

$$P_1 = P_0 + h\rho g. \text{ Hence } P_1 = (1.01 \times 10^5) + (0.4 \times 10 \times 1000) = 1.05 \times 10^5 \text{ N/m}^2.$$

Measuring pressure

1. *Simple mercury barometer*– it is constructed using a thick walled glass tube of length **1 m** and is closed at one end. Mercury is added into the tube then inverted and dipped into a dish containing more mercury. The space above the mercury column is called torricellian vacuum. The height ' h ' (if it is at sea level) would be found to be

760 mm. Atmospheric pressure can be calculated as,

$$P = \rho g h \Rightarrow \text{where } \rho \text{ (mercury)- } 1.36 \times 10^4 \text{ kg/m}^3, \text{ } g\text{- } 9.81 \text{ N/kg, } h\text{- } 0.76 \text{ m.}$$

$$\text{Then } P = (1.36 \times 10^4) \times 9.81 \times 0.76 = 1.014 \times 10^5 \text{ Pa.}$$

NOTE- this is the standard atmospheric pressure, sometimes called **one atmosphere**. It is approximately **one bar**.

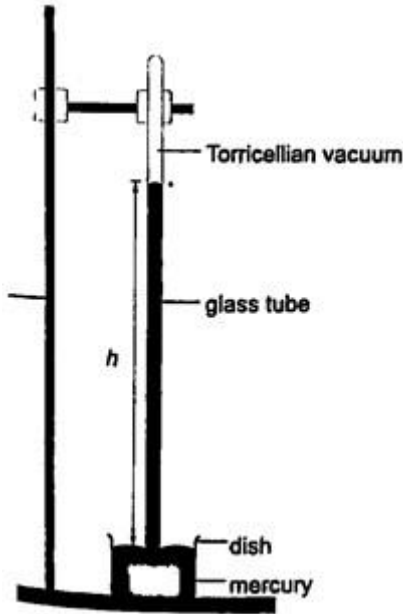

2. *Fortin barometer*—this is a more accurate mercury barometer. The adjusting screw is adjusted first to touch the mercury level in the leather bag.

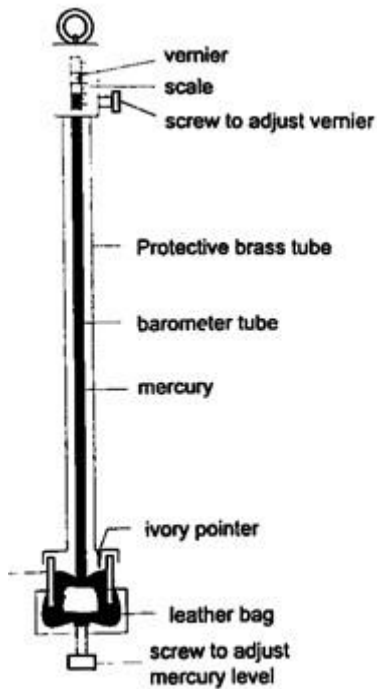

Fortin barometer

3. *Aneroid barometer*—increase in pressure causes the box to contract, the movements are magnified by the system of levers and is transmitted to the pointer by the fine chain and this causes the pointer to move. The scale is suitably calibrated to **read pressure**. Since pressure falls or rises as altitude falls or rises, the pointer can also be calibrated to read **altitude**.

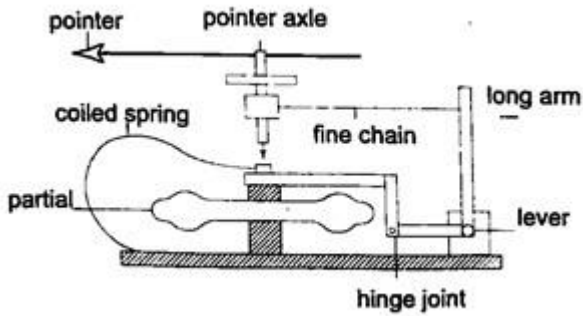

4. *Bourdon gauge*– it is also called **gauge pressure** and is used in **gas cylinders**. When air is blown into the rubber tube, the curved metal tube tries to straighten out and this causes movement which is transmitted by levers and gears attached to a pointer. This gauge can measure both gas and liquid pressure.

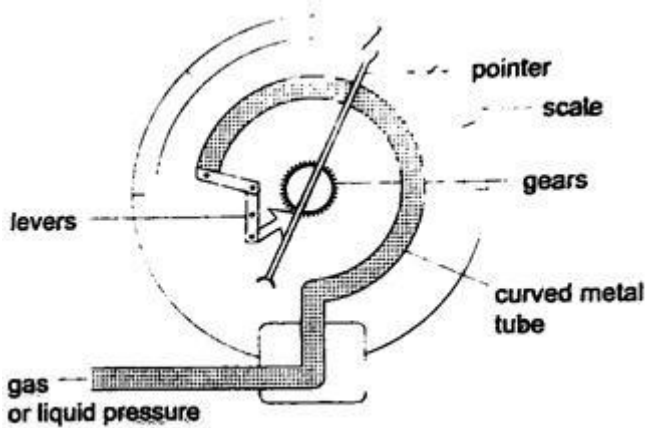

Examples

1. The height of the mercury column in a barometer is found to be 67.0 cm at a certain place. What would be the height of a water barometer at the same place? (densities of mercury- $1.36 \times 10^4 \text{ kg/m}^3$ and water- $1.0 \times 10^3 \text{ kg/m}^3$).

Solution

Let the pressure due to water be $h_1 \rho_1 g_1$ and that of water be $h \rho g$. Then $h_1 \rho_1 g_1 = h \rho g$. Hence $h_1 = (6.7 \times 10^{-1}) \times (1.36 \times 10^4) / 1.0 \times 10^3 = 911.2 \text{ cm}$ or 9.11 m.

Application of pressure in gases and liquids.

1. *Rubber sucker*– this is a shallow rubber cap. Before use it is moistened to get a good seal then pressed firmly on a smooth surface so that the air inside is pushed out. The

atmospheric pressure will then hold it firmly against the surface as shown below. They are used by printing machines to lift papers, lifting glass panes, etc.

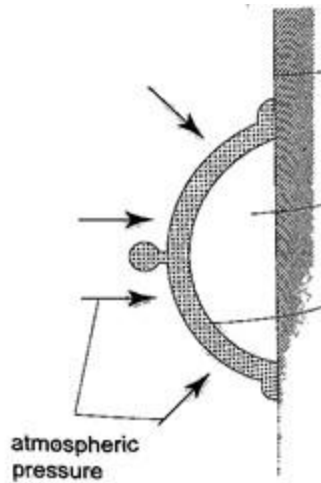

pressure will then hold it firmly against the surface as shown below. They are used by printing machines to lift papers, lifting glass panes, etc.

2. *Drinking straw*– straw air is sucked leaves the space in atmospheric in the container inside the straw and this forces the liquid into your mouth.

when a liquid is drawn using a through the straw to the lungs. This the straw partially evacuated. The pressure pushing down the liquid becomes greater than the pressure

3. *The syringe*– they work in the principle as the straw. They are used by the doctors in hospitals for giving injections.

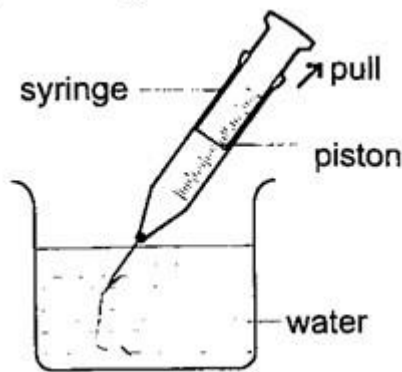

4. *Bicycle pump*– it uses two valves, one in the pump (greasy leather) and the other in the tire. When the handle is pushed in, the pressure inside the barrel becomes greater than the one in the tire and this pushes air inside. The valve in the tire is made such that air is locked inside once pumped.

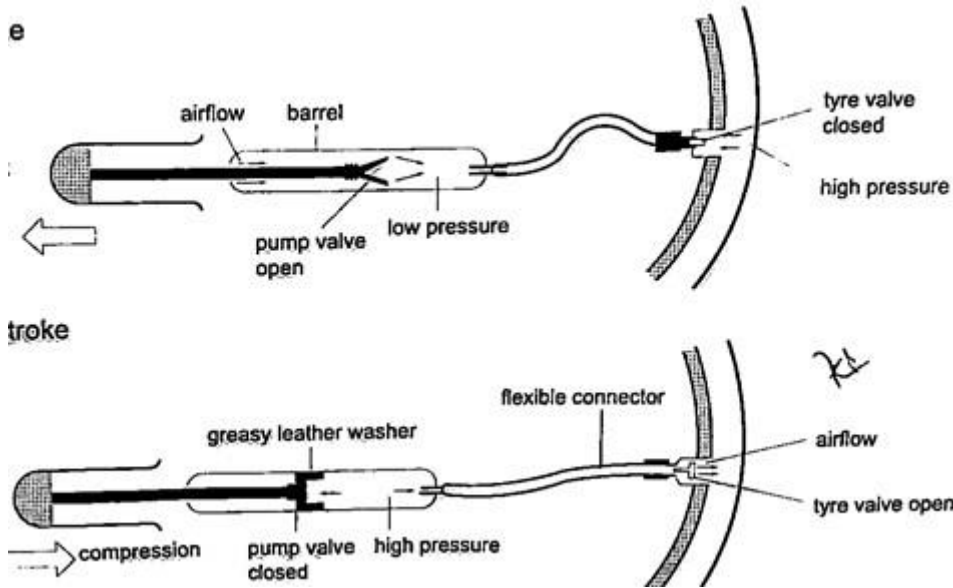

5. *The siphon*– it is used to empty tanks which may not be easy to empty by pouring their contents out. The tubing must be lowered below the base of the tank. The liquid flows out due to pressure difference caused by the difference in height ($h \rho g$).

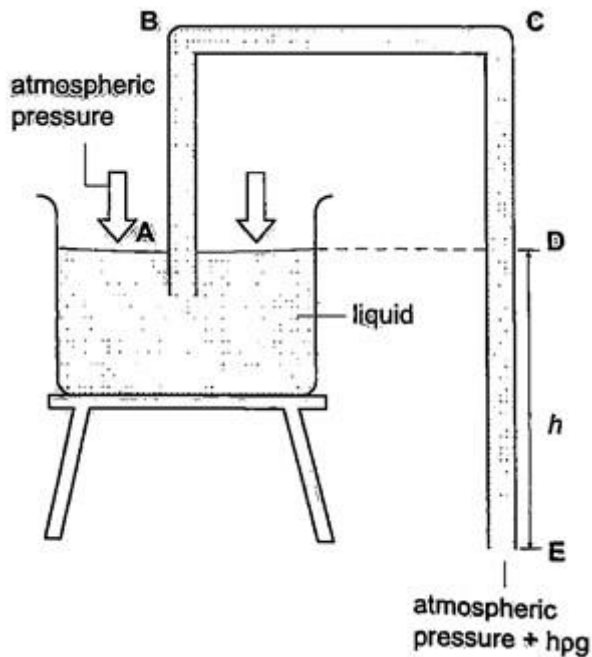

6. *Lift pump.*
7. *Force pump.*

Transmission of pressure in liquids and gases.

It was first recognized by a **French** mathematician and physicist called **Blaise Pascal** in the **17th century**. Pressure is equally distributed in a fluid and equally transmitted as shown in the following,

- a) *Hydraulic brake system*– the master cylinder transmits pressure to the four slave cylinders on each wheel. The cylinders contain brake fluid. Fluid is used because liquids are almost incompressible. When force is applied in the pedal the resulting pressure in the master cylinder is transmitted to the slave cylinders. This forces the piston to open the brake shoes which then pushes the brake lining against the drum. This force the rotation of the wheel to slow down. It is important to note that pressure is equally distributed in all wheels so that the car doesn't pull or veer to one side.

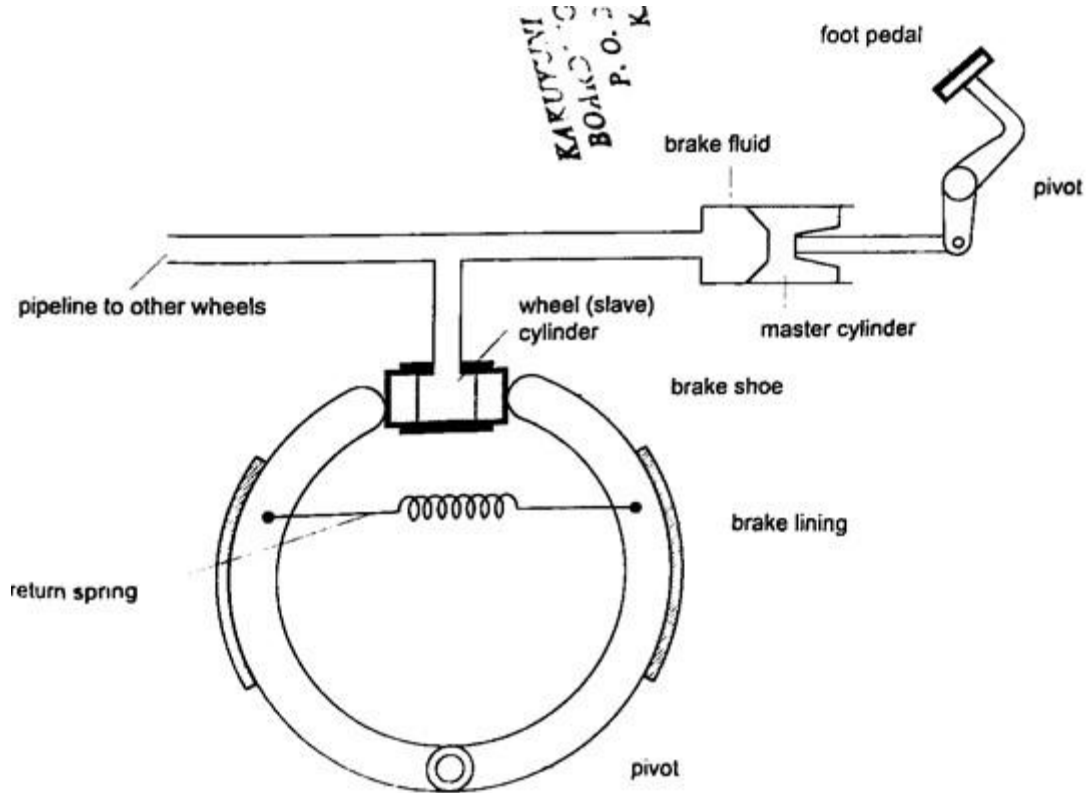

- b) *Hydraulic press*– it consists of two pistons with different cross-sectional areas. Since pressure is transmitted equally in fluids, when force is applied in one piston it is transmitted to the other piston. The smaller piston is called the force while the bigger piston is called the load. They are used to lift heavy loads in industries, bending metals and sheets etc.

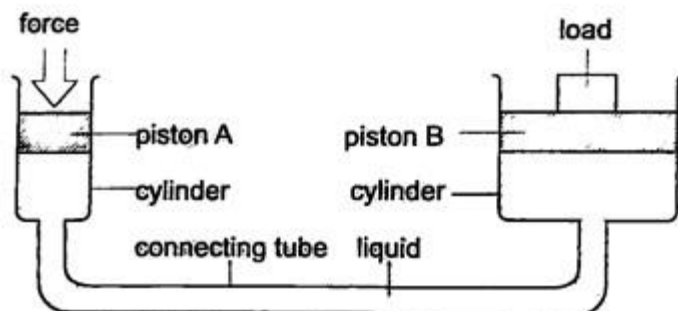

Examples

1. The area of the smaller piston of a hydraulic press is 0.01 m^2 and that of the bigger piston is 0.5 m^2 . If the force applied to the smaller piston is 2 N , what force is transmitted to the larger piston?

Solution

Pressure = force / area – hence $P = 2 / 0.01 = 200 \text{ Pa}$.

Force = Pressure \times Area = $200 \times 0.5 = 100 \text{ N}$.

2. The master cylinder piston in a car braking system has a diameter of 2.0 cm . The effective area of the brake pads on each of the four wheels is 30 cm^2 . The driver exerts a force of 500 N on the brake pedal. Calculate a) The pressure in the master cylinder

b) The total braking force in the car.

Solution

- a) Area of the master cylinder – $\pi r^2 = 3.14 \text{ cm}^2$

Pressure = force / area = $500 / 3.14 \times 10^{-4} = 1.59 \times 10^6 \text{ N/m}^2$

- b) Area of brake pads = $(30 \times 4) \text{ cm}^2$. Since pressure in the wheel cylinder is the same as in the master cylinder)

$F = \text{Pressure} \times \text{Area} = (1.59 \times 10^6) \times (120 \times 10^{-4}) = 1.91 \times 10^4 \text{ N}$.

CHAPTER FIVE

PARTICULATE NATURE OF MATTER.

States of matter

Matter is anything that occupies space. Matter exists in three states: **solids, liquids** and **gases**. Matter can be changed in various ways which includes **physical, chemical** and **nuclear** changes.

- a) **Physical changes**– they are normally reversible and no new substances formed.

Examples are;

(i) Change of state such as melting and vaporization

(ii) Thermal expansion due to heating

(iii) Dissolving solids in liquids

(iv) Magnetizing

(v) Charging electrically

- b) **Chemical changes**– they are irreversible and new substances are formed

Examples are;

- (i) Changes caused by burning
- (ii) Changes occurring in some chemicals due to heating e.g. mercuric oxide (iii) The reactions resulting from mixing chemicals to form other substances.
- c) Nuclear changes– these are changes occurring in nuclear substances which give off some particles i.e. Uranium and Radium. As this happens they change into other substances.

Particulate nature of matter

Matter is made up of millions of tiny particles which cannot be seen with naked eyes. These particles are called atoms and are made up of **sub-atomic** particles called **protons**, **neutrons** and **electrons**. Atoms join together to form **molecules**.

Movement of particles

Particles move from one region to another by the process of diffusion. **Diffusion is the movement of molecules from regions of high concentration to regions of low concentration until an equilibrium is reached or achieved.** Gases diffuse faster or readily than liquids. The rate of diffusion depends on the manner of arrangement of individual particles. *Solids*

Individual atoms in solids have a small space between them hence their forces of attraction are very strong. They vibrate in their fixed positions and this gives solids a fixed shape.

Liquids

Forces of attraction between liquid molecules are not as strong as in solids where motion is not restricted. They collide with each other as they move about. They take the shape of the container they are put in hence have no definite shape.

Gases

Molecules of atoms in gaseous state are further apart experiencing very small forces of attraction. This makes them almost completely free from each other. We say they are independent in space. Gases have no definite shape and volume but they take up the space and volume of the container they are put in.

CHAPTER SIX

THERMAL EXPANSION.

Introduction

Temperature is the degree of hotness or coldness of a body. Both **Celsius scale (°C)** and **Kelvin scale (thermodynamic scale)** are used to measure temperature. The Kelvin scale is also known as the **absolute scale temperature** and is measured from **absolute zero (0 K)**.

Expansion of solids

When solids are heated they expand. The expansion is so small such that we can't see them.

The following experiments will demonstrate actual expansion of solids.

Experiment 1:- Ball and ring experiment

Procedure

1. Obtain a ball and ring apparatus.
2. Pass the ball through the ring at room temperature and observe that it easily slips through.
3. Heat the ball using a Bunsen burner for one minute.
4. Try to pass the ball through the ring and observe what happens.
5. Let it cool for some time and try passing the ball again.

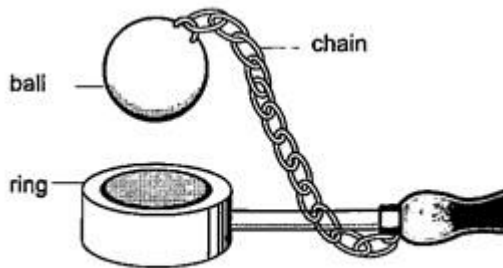

Discussion

When the ball is heated it expands and increases in diameter. This makes the ball not to pass through the ring. After cooling it is found that the ball slips through the ring easily again.

Experiment 2:- The bar-breaker Procedure

1. Try and break the cast-iron pin with your hands. Can you? (A bar-breaker is a strong iron frame which holds a steel bar fitted with a wing-nut. The other end is held by cast-iron pin as shown below).
2. Tighten the nut but do not break the pin.
3. Heat the bar strongly using two Bunsen burners as you keep tightening the nut.
4. Continue heating for another five minutes then let it cool.
5. Observe what happens.

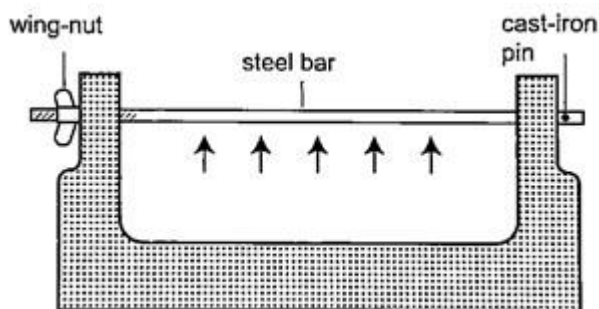

Discussion

When the bar cools the cast-iron pin breaks. This shows that as the bar cools it contracts and strong forces pull against the pin. These forces makes the pin to break.

Experiment 3:- Heating a bimetallic strip

Procedure

1. Heat a brass-iron bimetallic strip using a Bunsen burner and make sure it is heated evenly.
2. Observe what happens after a short while.

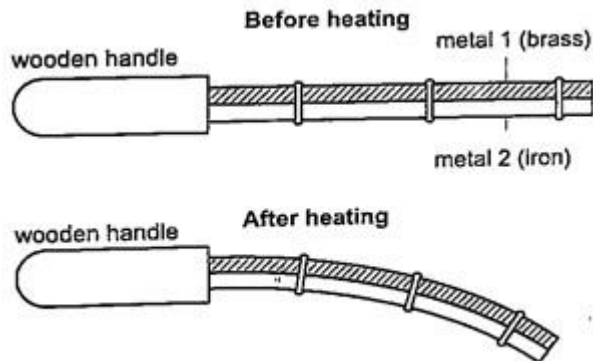

Discussion

When a **brass-iron bimetallic** strip is heated it bends towards the iron. This means that brass expands more than iron and this causes the strip to bend towards the iron side. This shows that different materials expand at different rates when heated.

Applications of the expansion of solids

1. **Construction of railway lines**– an expansion joint is allowed between any two rails to accommodate expansion. A **fish plate** is used to join two rails. Modern railway system use the **overlapping** joint at the end of rails.

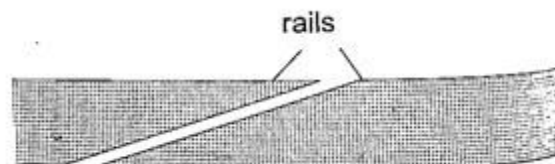
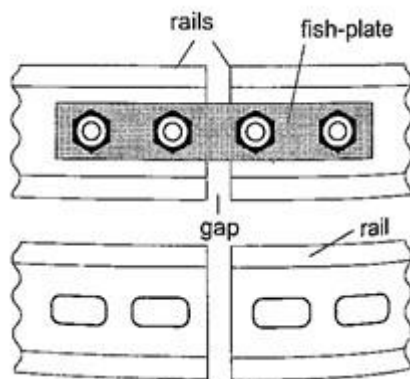

2. *Construction of bridges and roof tops (steel girders)*– for bridges one side has rollers while the other is fixed to allow for expansion. Concrete slabs are also laid on the ground leaving space filled with pitch to allow for expansion.

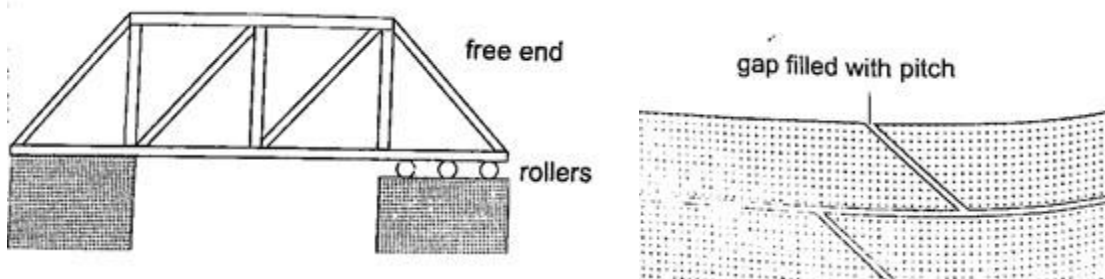

3. *Hot water pipes*– pipes carrying hot water (steam) from boilers are fitted with expansion joints for expansion.

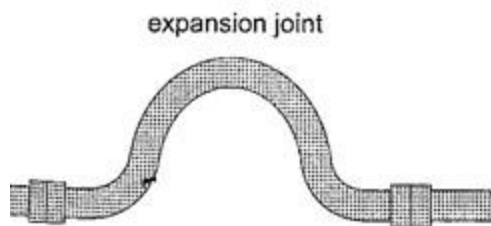

4. *Riveting* – used to join two pieces of metal together i.e. bimetallic strips, car bodies, drums etc. Fitting rail cart wheel using heat uses the principle of rivets. Bimetallic strips are used in thermostats (control temperature) – electric iron box, alarm systems, car flasher units etc.

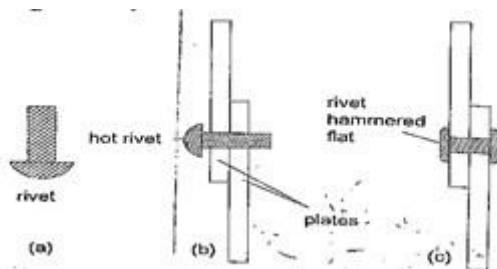

Expansion of liquids and gases.

Expansion of liquids.

Liquids expand more than solids so it is easy to observe and see clearly as they expand. We use the hot water bottle to demonstrate the expansion of water. Water is put in the bottle as shown below.

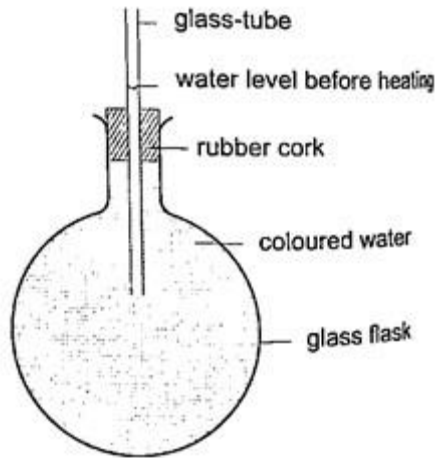

When the bottle is immersed in hot water, initially there is a drop in the level of water in the glass tube then it steadily rises after a while. This shows that liquids expand with increment in volume as shown by the hot water bottle. Different liquids expand at different rates as shown below.

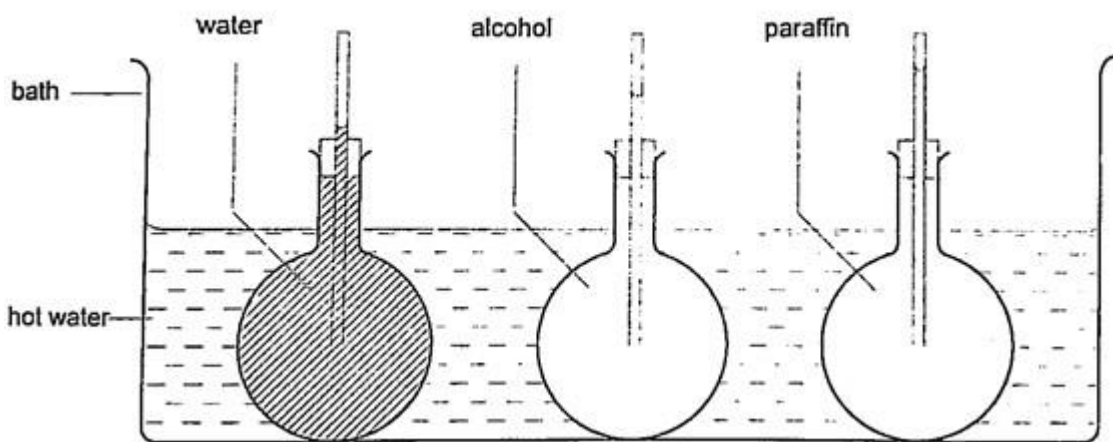

Expansion of gases

They are the easiest to observe since they expand the most.

Experiment: - Expansion of air

Procedure

1. Obtain an empty 500 ml round bottomed flask fitted with a cork and a glass tubing.
2. Place a beaker with some water on a bench.
3. Rub your hands together thoroughly and place them on the flask and place it in the water as shown.
4. Observe what happens.

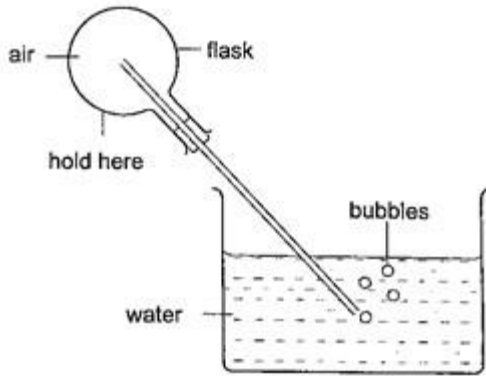

Discussion

The heat produced by the hands makes the air inside the flask to expand. This makes the volume to increase and therefore force the excess air out as bubbles.

Applications of the expansion of gases and liquids.

1. *Land and sea breeze*– during the day the land is heated by the sun causing the air above it to expand. The air becomes less dense therefore it rises. The space left is quickly filled by another cool air (generally from the sea since the land gets hot faster). This causes a cool breeze form the sea during the day. At night the land loses heat faster than the sea. The air above the sea rises since it is less dense and cool air from the land rushes to fill the gap. This causes a breeze blowing from the land to the sea.

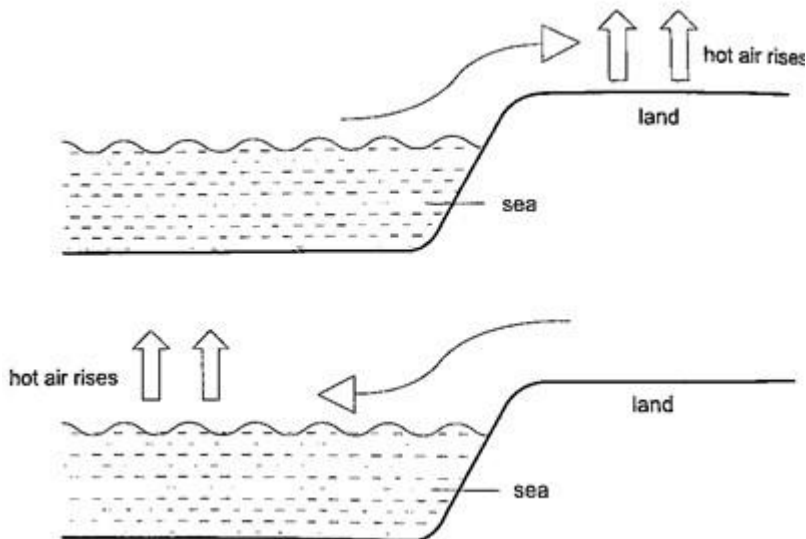

Thermometers

1. *Liquid-in-glass thermometer*–this applies to the expansion of a liquid in a thin-walled glass-tube. The liquid moves up the tube when the bulb is heated. The liquid must be a **good conductor**, **visible** and be able to **contract and expand quickly** and **uniformly** over a wide range of temperatures. It should also **not stick** on the sides of

the tube. Liquids commonly used are **mercury** and **coloured alcohol**. The scale is obtained by choosing two temperature points called fixed points. In Celsius lower point is taken to be 0°C (when placed in ice) and the upper point as 100°C (boiling steam). The two points are therefore divided into 100 equal parts (calibration). The melting and boiling points of both **mercury** and **alcohol** are ($-39^{\circ}\text{C} - 357^{\circ}\text{C}$) and ($-112^{\circ}\text{C} - 78^{\circ}\text{C}$) respectively.

2. *Clinical thermometer*– this is a special type of mercury-in-glass thermometer used to measure **body temperature**. Since body temperature is normally 37°C the scale is only a few degrees below and above 37°C . It has a **constriction** which **prevents mercury** from **going back** after expansion for convenient reading of temperature. This thermometer has a **narrow bore** for **greater sensitivity** and **accuracy**.

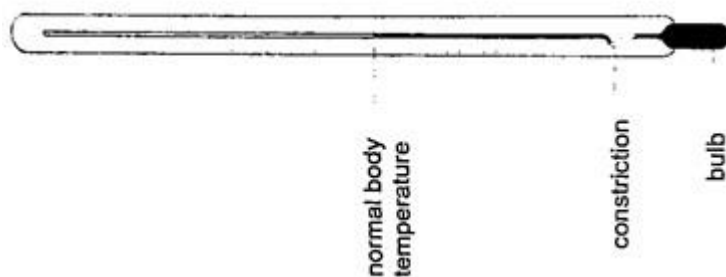

3. *Six's maximum and minimum thermometer*– it is used to measure temperature of **surroundings** of **an area** or **a place**. It can record both maximum and minimum temperatures attained. Consists of a large bulb (A) containing **oil of creosote** connected to U-shaped stem which connects to a second bulb (B) containing the same liquid. The base (C) contains a **thin thread of mercury**. The range of this

thermometer is between -20°C and 50°C . After each reading the indices are pulled down to the level of mercury by use of a magnet.

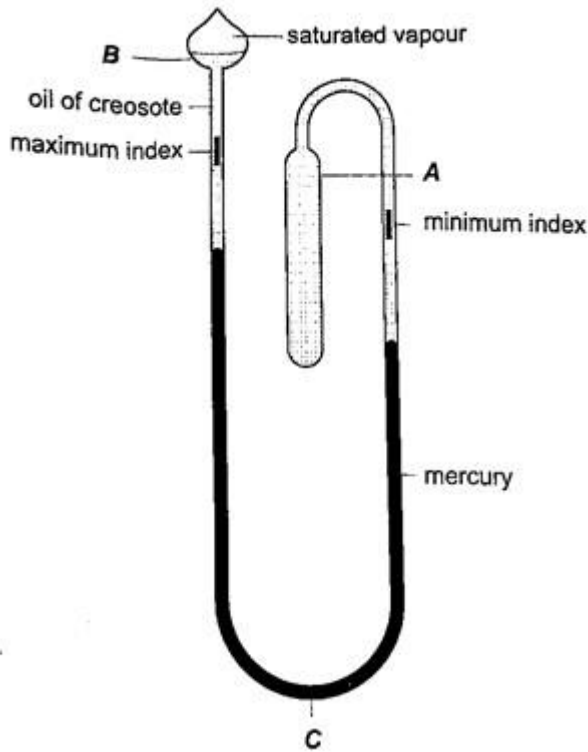

4. *Bimetallic thermometer*– it is made up of a bimetallic strip with one end fixed and the other connected to a pointer. Metals used are usually **brass** and **invar**. As temperatures increase the strip unwinds and moves the pointer over a calibrated scale. It is used to measure **high** temperatures.

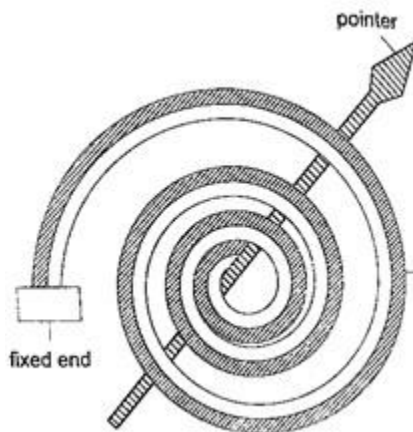

5. *Thermocouple thermometer*– thermocouple is a junction made of **copper** and **iron** looped at both ends. In practice a sensitive **millivoltmeter** is used instead of a galvanometer. A cold junction is maintained in melting ice (0°C) while the other junction is heated steadily. This thermometer does not apply the principle of expansion.

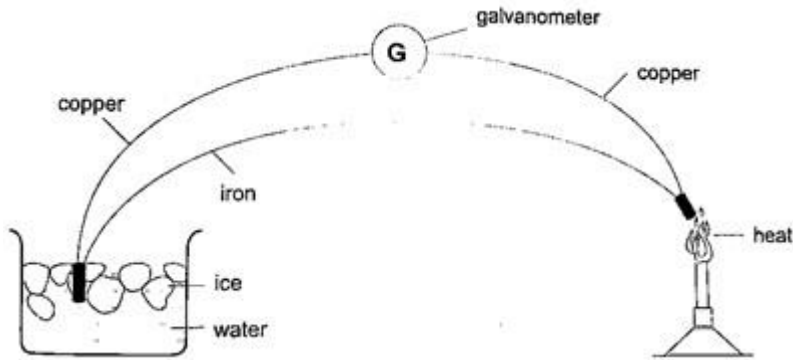

Unusual expansion of water.

If water is heated let's say from -15°C it expands normally like any solid but only up to 0°C . At this point it starts to melt and it contracts. This contraction will be observed up to 4°C . When heated further water starts to expand up to boiling point. This is the unusual expansion of water. This makes the top of water to freeze (0°C) in temperate countries allowing the one below to remain liquid (4°C). This supports **marine life** during **winter**.

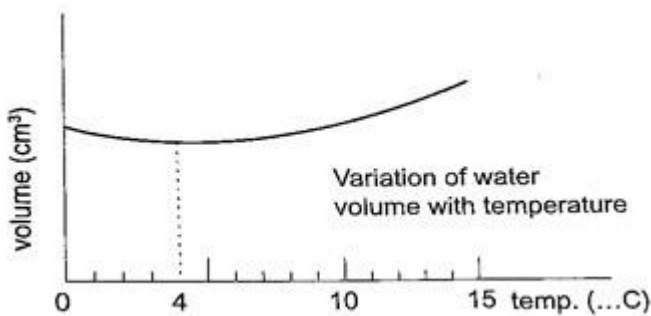

Molecules and heat.

1. Solids

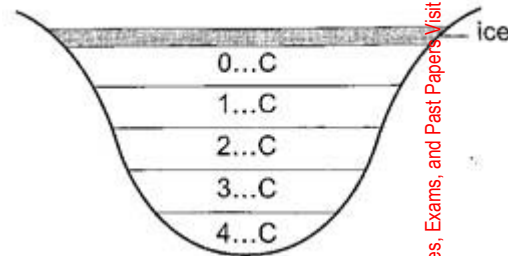

– when

heated molecules in solids absorb heat

energy and vibrate. They push against one another and this causes expansion. Further expansion may result to collapse as melting in ice.

2. *Liquids* – besides vibrating particles in a liquid move short distances. As they move they collide by hitting each other and this results to more expansion. For boiling to occur molecules absorb enough energy to be able to escape from the liquid.
3. *Gases* – individual particles are free of one another and in rapid motion. When heated there are collisions with the walls of the container. This results to high pressure in the container.

CHAPTER SEVEN HEAT TRANSFER.

Heat is transferred in matter through the following methods: **conduction**, **convection** and **radiation**.

Conduction

This is the transfer of heat in solids. The rate of conduction depends on

1. Amount of temperature – the higher the temperature the higher the rate of transfer.
2. Cross-sectional area – the larger the cross-sectional area the higher the transfer.
3. Length of material – the shorter the material the higher the rate of transfer.
4. Type of material – different materials transfer heat at different rates.

Good and bad conductors

Conductivity is the ability of a material to conduct heat. Good conductors of heat are those materials which are able to transfer heat easily and steadily. Bad conductors are those which do not conduct heat.

Experiment: Comparing thermal conductivity of metals

Procedure

1. Obtain four identical rods of copper, iron, aluminium and brass.
2. At one end of each rod attach a matchstick using paraffin wax and let it solidify.
3. Place the rods on a tripod stand with the free ends close to one another as shown.
4. Heat the free ends strongly with a Bunsen burner.
5. Observe what happens.

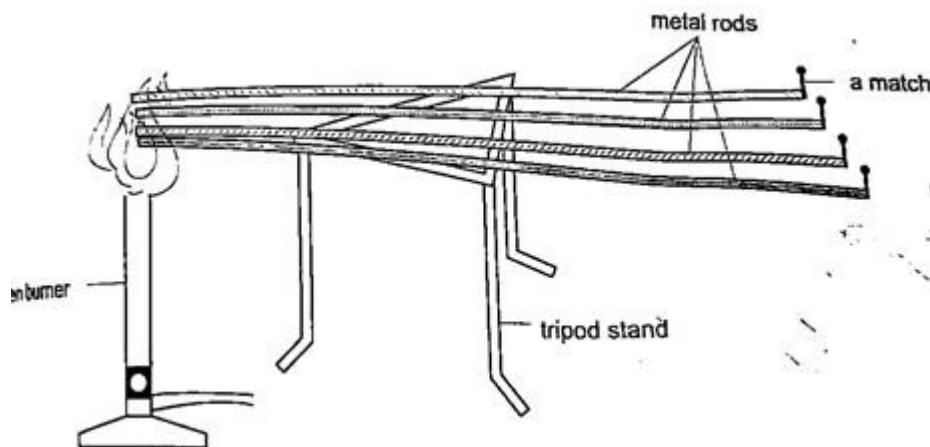

Discussion

When done correctly and carefully the matchsticks will fall off in the following order: copper, aluminium, brass and finally iron. This shows that different metals conduct heat at different rates.

NOTE – on a cold morning a metallic chair would feel cold compared to a wooden chair at the same temperature, this is because the metallic chair absorbs heat from your body as opposed to wood which is a bad conductor of heat. Applications of conductors

Good conductors

1. They are used to manufacture cooking utensils
2. They are used as liquids suitable for thermometers i.e. mercury
3. Used as heat dumps (metal clips) when soldering delicate components in a circuit board i.e. transistors

Poor conductors

1. Used as insulators in handles of cooking utensils
2. Used in making good winter clothes i.e. wool
3. Hot water cylinders are lagged with fibre-glass since glass is a poor conductor of heat.
4. Houses in cold countries have double walls with air trapped in them to keep them warm.

Convection

This is the transfer of heat through fluids (liquids and gases). This occurs when part of the fluid is **heated**: they become less dense and rise above the cold fluid. As they move they carry heat with them. In convection we observe streams of moving fluid called **convective currents**. Convection in air

Experiment: model chimney (smoke box)

Procedure

1. Obtain a model chimney system or construct one as shown
2. Place a lighted candle under one of the chimneys
3. Place a smouldering cloth near the other chimney and observe what happens.

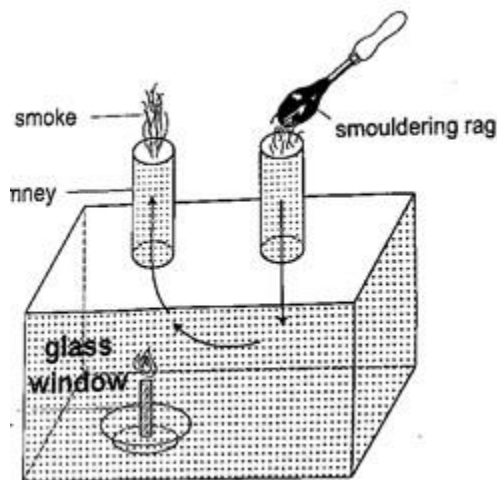

Discussion

Smoke will be seen going into the chimney and coming out through the other chimney. The air above the candle gets heated and rises up the chimney causing convective currents which carry the smoke out with them.

Experiment: revolving paper-vane

Procedure

1. Make a paper-vane by cutting a thin card as shown
2. Put a string through the hole in the centre and hold it above a lighted Bunsen burner.
3. Observe what happens.

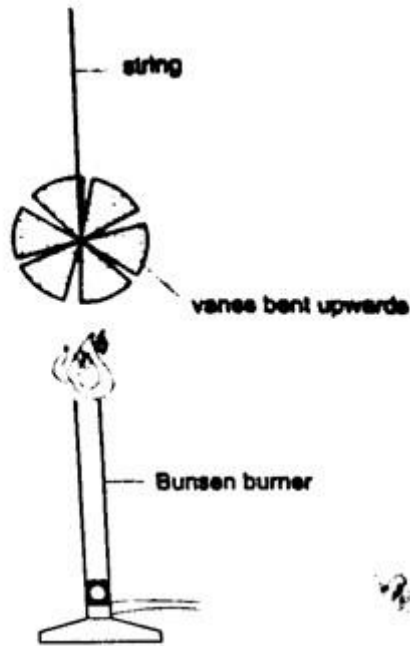

Discussion

As the air above the flame gets heated convectional currents are formed and rise upwards. As these currents brush against the paper-vane it rotates. **Convection in liquids**

Experiment: heating water in a beaker

Procedure

1. Put water in a beaker until it is three quarters full and place it on a tripod stand.
2. Drop a crystal of potassium permanganate through a tube to settle at one corner at the bottom of the flask.
3. Heat the water gently using a Bunsen burner and observe the movement of streams of colour.

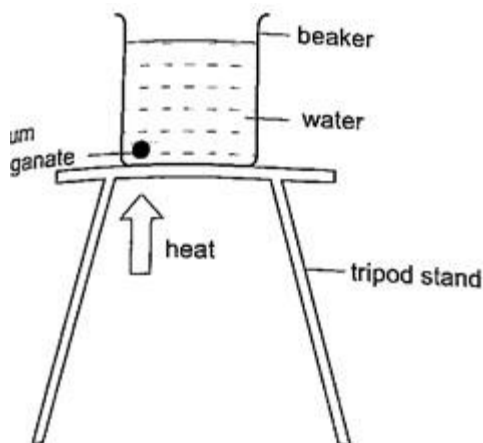

Discussion

A stream of colour will be seen moving upwards and downwards again at the other side of the beaker. This will continue gradually until all the water becomes coloured. This shows that convectional currents also exist in liquids.

Experiment: model of hot water system

Procedure

1. Obtain two flat bottomed flasks and set up the apparatus as shown below.
2. Hold the flasks in place by use of clamp stands.
3. Heat the bottom of the lower flask and observe what happens.

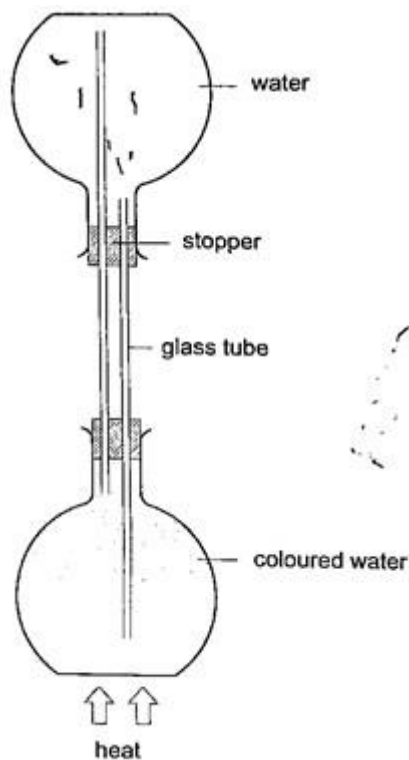

Discussion

When the water in the lower flask becomes hot it rises up to the upper flask. After some time the water in the upper flask will become hot due to convectional currents.

Applications of convection

1. Brings about the land and sea breezes.
2. Can be used to explain the weather phenomena.
3. Used in car radiators.

- Used in immersion water heaters by placing them at the bottom.

Radiation

This is simply the flow of heat from one point to another by means of electromagnetic waves.

Radiation from different surfaces

We use the **Leslie cube** to determine radiation of different surfaces. It is a rectangular metal container of square base with small opening at the top. One side is coated with **polished silver**, another **dull black** (candle flame soot), the other **grey** and the fourth **white**.
Experiment: Radiation from different surfaces

Procedure

- Place a Leslie cube on a tripod stand and attach a thermometer on each of the four sides.
- All thermometers should be at least 5.0 cm from the surface and should read the same temperature.
- Pour hot water (about 80 °C) until it is full and note the reading of each thermometer after 1 minute.
- Repeat the above procedure using boiling water (100 °C).

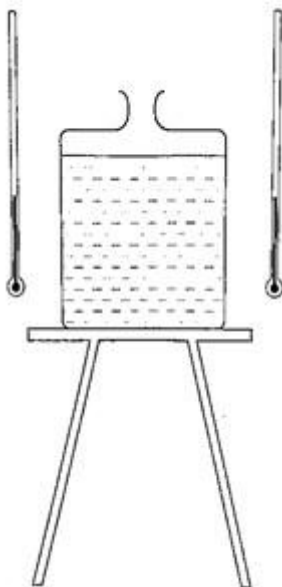

Discussion

The thermometer against the black surface records the highest temperature, followed by the one on the grey side, then the white surface while the polished side recorded the lowest temperature. The readings when the water is boiling were higher, indicating that radiation depends on temperature. It also depends on the nature of surface.

Applications of radiation

- Electric kettles have a chrome coat to reduce radiation.
- Electric iron are silver coated to minimize radiation.

3. Green houses use radiation (heat trap) to grow crops.
4. Clouds reflect radiation back to the earth hence cloudy nights are warmer than clear nights.

Vacuum flask

It was developed by **Sir James Ivarin 1890**. It keeps a liquid hot or cold (depends on what is put in). The liquid stays at the temperature it is poured in either hot or cold. It has the following principle features;

- (i) The vacuum between the double walls
- (ii) The two interior walls coated with silver
- (iii) Insulating cork supports (anti-shock pads)
- (iv) Insulating cork stopper at the top.

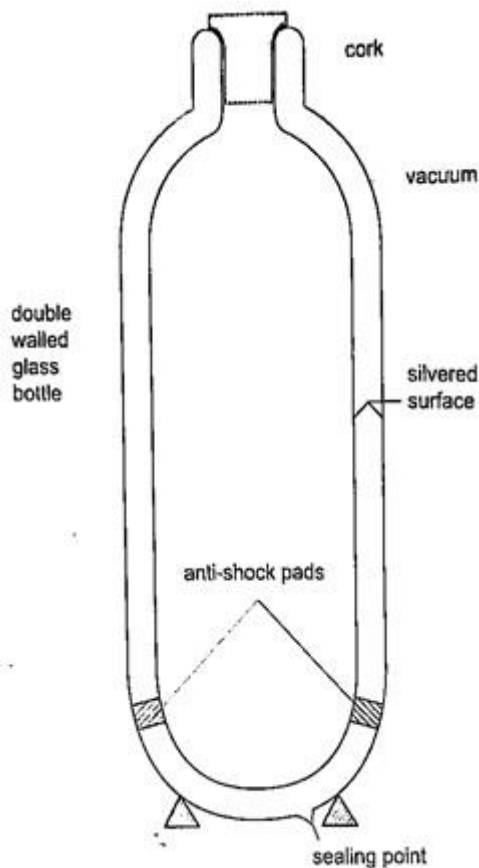

CHAPTER EIGHT

RECTILINEAR PROPAGATION AND REFLECTION AT PLANE SURFACES.

Introduction

Objects that produce their own light are known as **luminous** objects i.e. the sun, torch lamps etc. objects that do not produce their own light are called **non-luminous** objects i.e. the moon. **Opaque** objects are those which do not allow light to pass through them.

Translucent materials are those which allow light to pass through them but we cannot see through them i.e. church glass and bathroom glass. **Transparent** materials are those which allow light to pass through them and we can see through them i.e. window panes, car windows etc. A **ray** is the direction of the path followed by light. A **beam** is a group of rays travelling together.

Experiment: light travels in straight lines

Procedure

1. Obtain three cardboards with a hole at the center and mount them such that they form a straight line.
2. Arrange them as shown and place a lighted candle at one end and make sure that you can see the flame from the other end.
3. Move any of the cardboards and observe what happens.

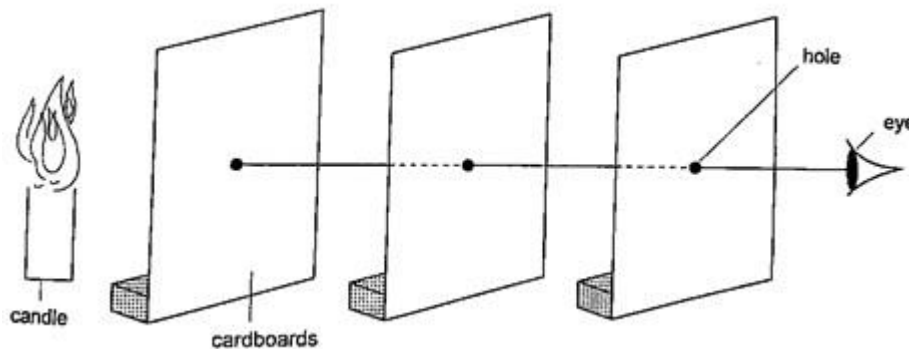

Discussion

When one cardboard is displaced or moved slightly the flame cannot be seen at the other end. This shows that light travels in a straight line. This principle is applied in the following,

Pinhole camera

It consists of a closed box with a small hole on one face and a screen of tracing paper/ frosted glass on the opposite face as shown. An image will be formed on the screen. Since light travels from one point of the object through the hole an image will be formed on the opposite screen of the box. If the object is near the hole it is magnified while diminished if away from the hole. **Magnification is therefore the ration of the image to object height,** expressed as,

$$\text{Magnification} = \frac{\text{height of image}}{\text{height of object}} \text{ or } \frac{\text{distance of image from pinhole}}{\text{distance of object from pinhole}}$$

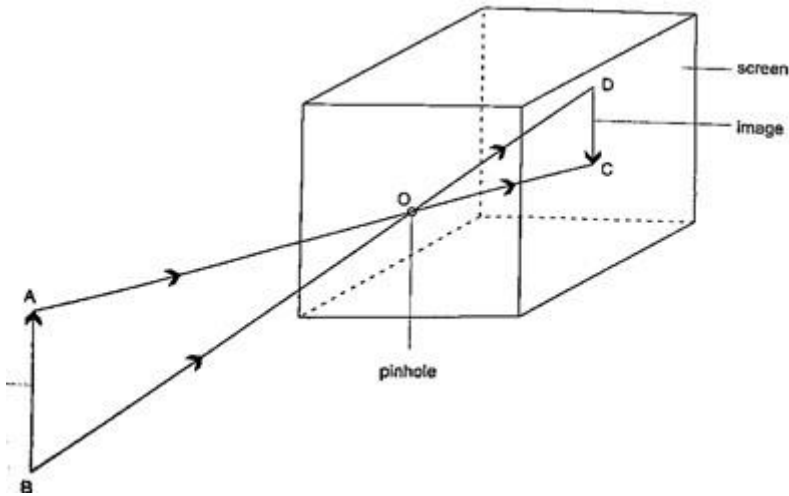

Shadows

Shadows are formed when an opaque object is placed between a source of light and a screen. When the shadow is big a **dark patch** at the centre is formed (**umbra**) while a surrounding **lighter patch** called **penumbra** is formed.

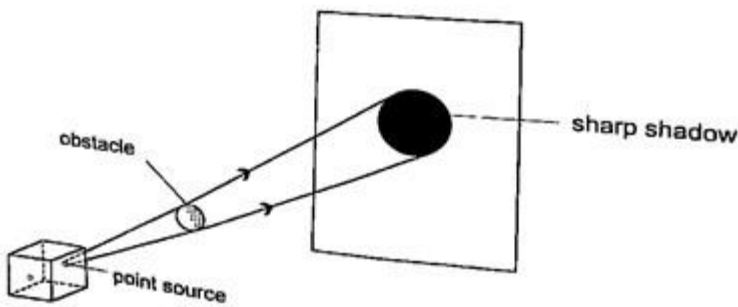

Eclipses

Eclipse of the sun (solar eclipse)

This occurs when the moon is between the earth and the sun. The shadow of the moon falls on the earth's surface. Sometimes the distance is large for the shadow to reach the

Annular eclipse

earth and when this happens an **annular** eclipse occurs.

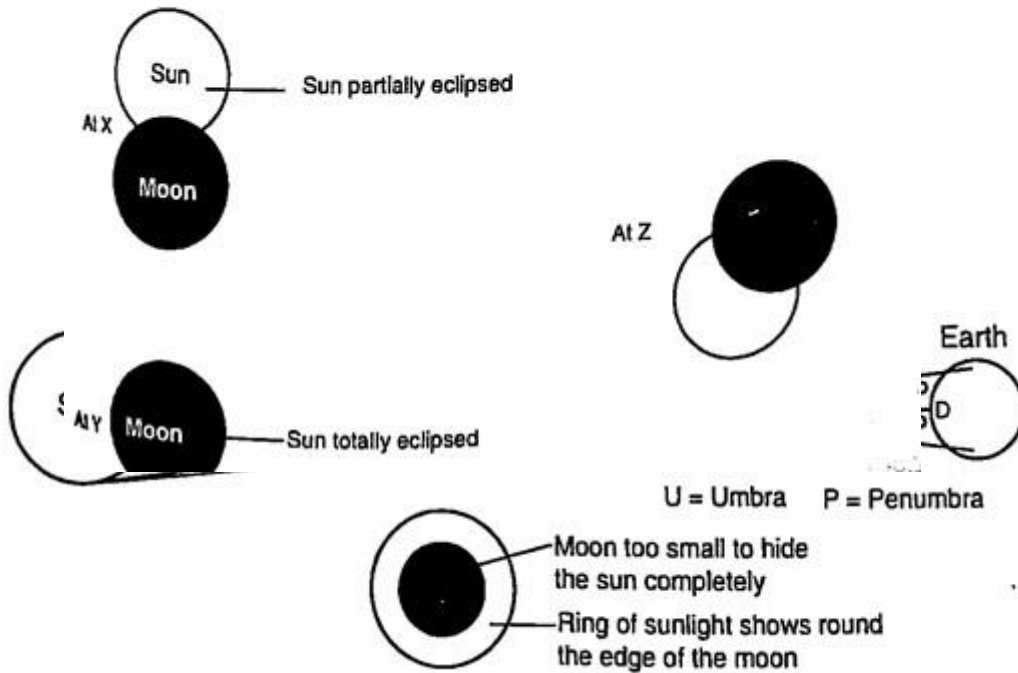
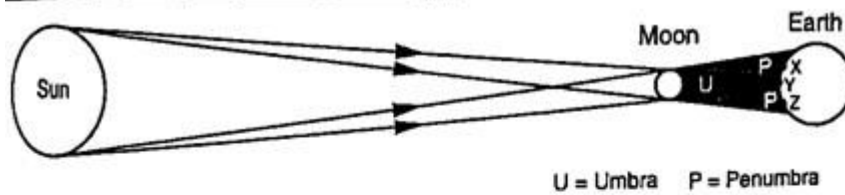

Eclipse of the moon

It is also known as **lunar** eclipse and occurs when the earth is between the sun and the moon. The shadow of the earth falls on the moon.

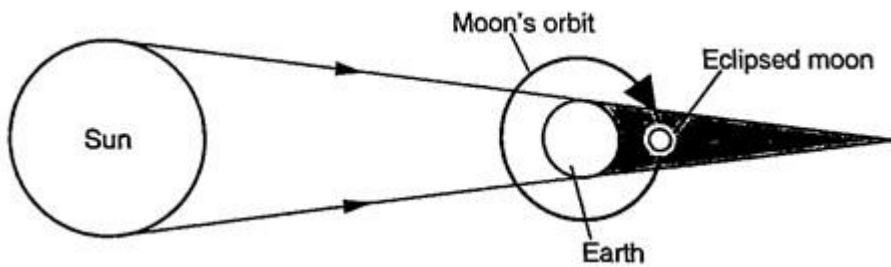

Examples

1. Calculate the height of a building 300 m away from a pinhole camera which produces an image 2.5 cm high if the distance between the pinhole and the screen is 5.0 cm.

Solution

Object distance = 300 m, image height = 2.5 cm, image distance = 5.0 cm.

Object height/ image height = object distance/ image distance

Object height = $(30,000 \times 2.5) / 5.0 = 15,000 \text{ cm} = 150 \text{ m}$.

- The length of a pinhole camera is 25.0 cm. An object 2.0 cm is placed 10.0 m from the pinhole. Calculate the height of the image produced and its magnification.

Solution

$$\begin{aligned} \text{Image height} &= (\text{image distance} \times \text{object height}) / \text{object distance} \\ &= (25 \times 200) / 10 = 500 \text{ cm or } 5 \text{ m.} \end{aligned}$$

$$\begin{aligned} \text{Magnification} &= \text{image distance} / \text{object distance} \\ &= 25 / 10 = 2.5 \end{aligned}$$

Reflection from plane surfaces

Diffuse and regular reflection

Regular reflection occurs when a parallel beam of light falls on a plane mirror and is reflected as a parallel beam. They occur on polished surfaces. A diffuse reflection occurs on rough surfaces where a parallel beam of light is reflected in all directions.

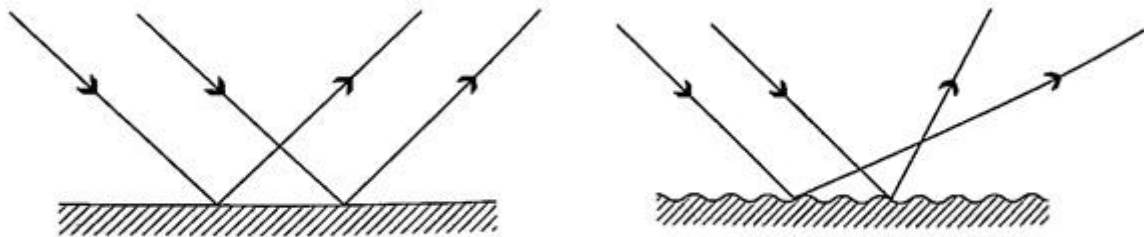

Laws of reflection

- The incident ray, the normal and the reflected ray at the point of incidence must be on the same plane

- The angle of incidence is equal to the angle of reflection.

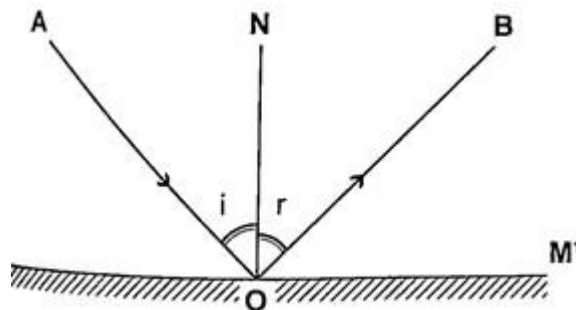

angle of incidence is equal to the angle of reflection.

Images from plane mirror

Characteristics of images formed in a plane mirror

- The image is the same size as the object
- The image is the same distance behind the mirror as the object is in front
- The image is laterally inverted
- The image is virtual
- The image is erect.

Images formed by reflection surfaces of images formed in a plane mirror are the same size as the object.

Location of an image by the non-parallax method

Parallax is the apparent relative motion of two objects due to the movement of the observer. It only occurs when the objects are at a distance from one another. This can be used to find the position of images in plane mirrors.

Experiment: To find the position of an image of a pin by non-parallax method

Procedure

1. Obtain a sheet of paper and draw a mirror line
2. Place the mirror on the line as shown
3. Place the pin at least 5 cm from the mirror and obtain another pin (search pin)
4. Move the pin till you get a point where there is no parallax and place your second pin.
5. Measure the distances (both image and object) and confirm your results.

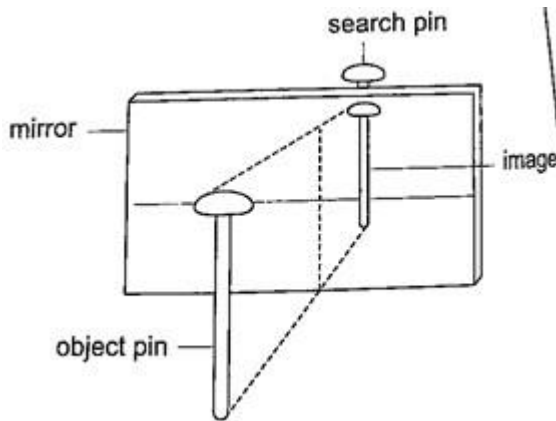

Mirrors at an angle

When mirrors are placed at an angle several images are obtained depending on the angle between them. If the angle is 60° the images formed will be five. We use the following formula to find the number of images

$$n = (360^\circ / \theta) - 1$$

When mirrors are parallel then the images formed are infinite.

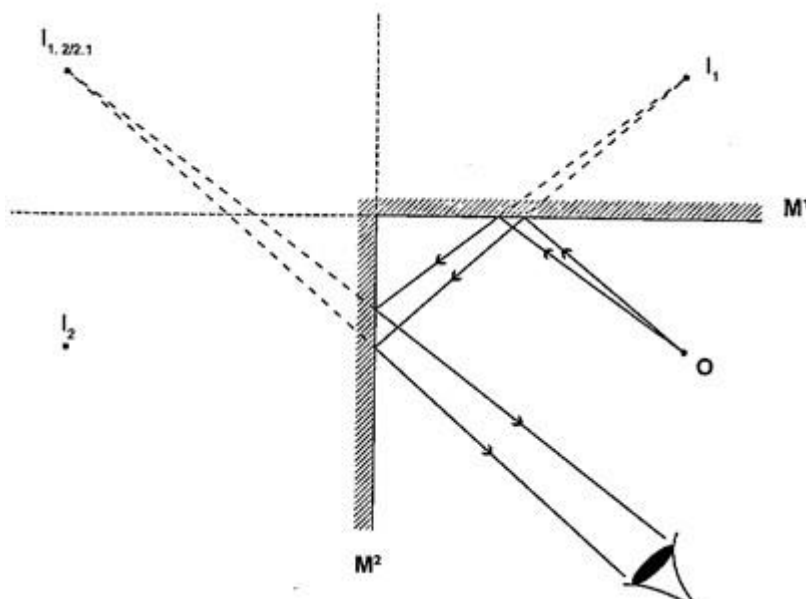

Kaleidoscope

It applies the principle of mirrors at an angle. Consists of two mirrors arranged at an angle of 60° to one another inside a tube. The bottom has a ground-glass plate with brightly coloured glass for allowing light. When one observes through the tube five images are seen.

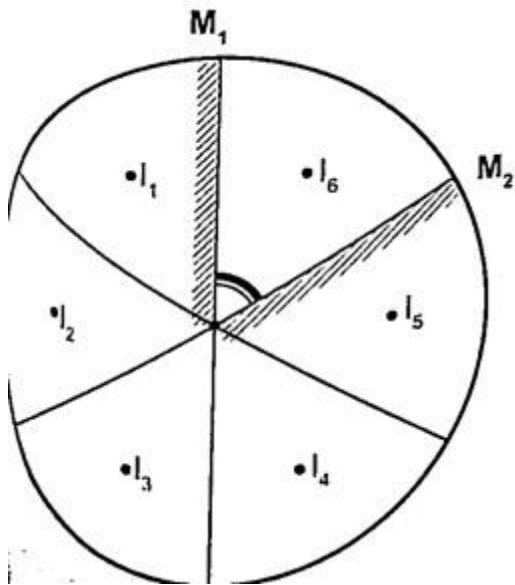

The periscope

This consists of two mirrors arranged at an angle of 45° as shown. This principle is used in periscopes (prisms) and telescopes.

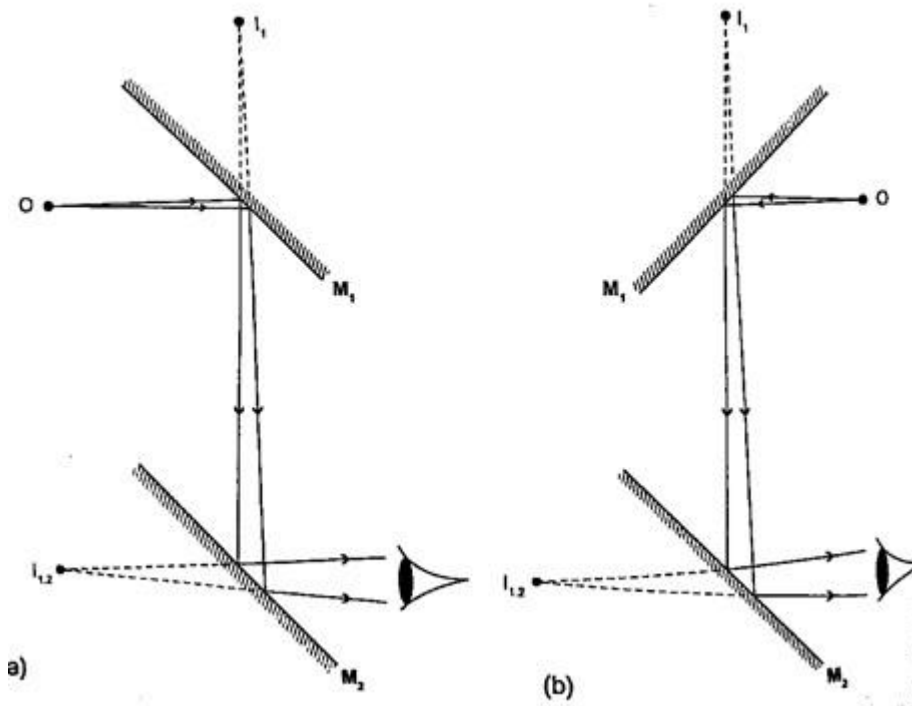

CHAPTER NINE ELECTROSTATICS

I.

Some substances get charged when rubbed against other substances i.e. nylon, plastic, paper etc. the charge acquired stays within the body i.e. it does not move and therefore known as electrostatic charge or static electricity.

The law of charges – types of charges

There are two types of charges i.e. negative and positive charges. The negative charge consists of electrons which are mobile. The **law of charges** in summary states that **“like charges repel, unlike charges attract”**. Just like in magnetism attraction is not a sure way of testing for charge but repulsion because it will only occur if the bodies are similarly charged.

Charges, atoms and electrons

The atom is made up of a central part called the **nucleus**, containing positively charged ions called **protons** and outwardly surrounded by negatively charged **electrons**. The nucleus also contain the particles called **neutrons** which are not charged. When an atom is not charged the number of protons equals the number of electrons. When a material is rubbed with another i.e. acetate with silk, electrons are transferred from one body to another. The body accepting or receiving electrons becomes negatively charged while the one donating or losing electrons becomes positively charged. Protons and neutrons in the nucleus do not move. The **SI unit for charge** is the **Coulomb (Coul.)**

1 Coul. = charge on 6.25×10^{18} electrons.

Charge on one electron = 1.60×10^{-19} Coul.

1 Coul. = 1 Ampere second (As).

The leaf electroscope

This is a sensitive instrument for measuring charge. It consists of a metal cap connected to a stem whose lower part is flattened into a plate with a thin strip of aluminium foil attached to it. The plate and the leaf are enclosed in a metal casing which is earthed. The sides of the metal are made of glass to allow the leaf to be seen.

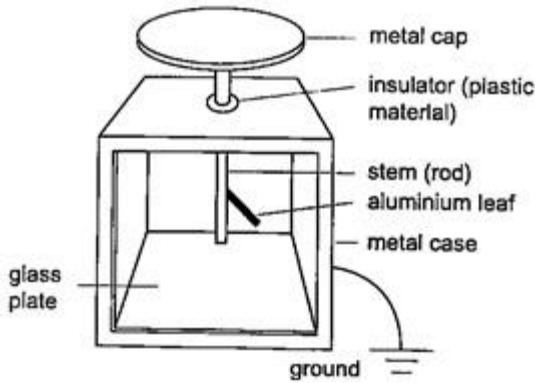

Other leaf electroscopes are made using **gold strips** and are referred to as **gold leaf electroscope**.

Charging and discharging an electroscope

When a charged body is brought near the cap of the electroscope the leaf diverges, and when removed it collapses. When a negatively charged body is brought near the metal cap electrons are repelled from the cap to the lower parts of the stem and the leaf. This concentration of negative charges makes the leaf to diverge. Similarly when a positively charged body comes near the metal cap the electrons are attracted by the protons and move up the stem, leaving a high concentration of positive charges which make the leaf to diverge.

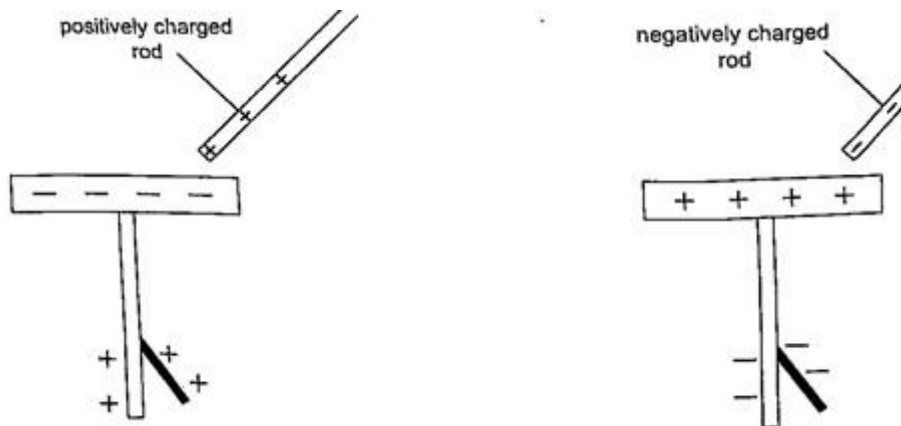

If you touch the metal cap with your finger the leaf collapses showing that the charges have been discharged through your body. An uncharged body will always cause the leaf of a charged electroscope to collapse regardless of the charge on the electroscope. This shows that charge moves from the charged electroscope to the uncharged body.

Conductors and insulators

Conductors are those substances which allow easy passage of a charge. Insulators do not allow a charge to pass through easily. A charged electroscope can be used to classify objects into conductors and insulators.

Experiment: Arranging objects into conductors and insulators.

Procedure

1. Charge an electroscope by rubbing it with fur until its leaf diverges.
2. Obtain a number of materials like aluminium, paper, copper, iron, cloth, glass, wood etc.
3. Hold these items in your hand in turns and touch the charged electroscopes' metal cap with it.
4. Record your results in the table shown below.

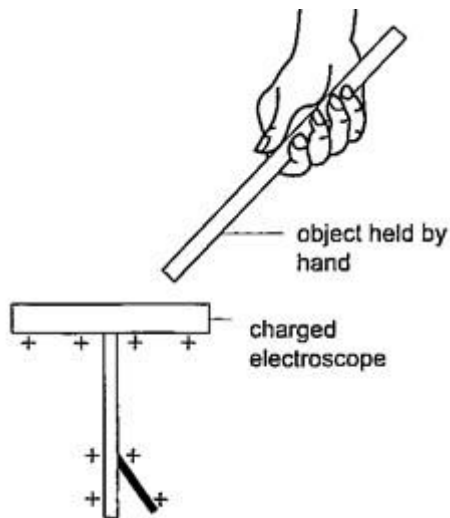

Material	Conductor	Insulator
Iron	√	
Cork		√
Aluminium	√	
Copper	√	
Paper		√

Charging an induction

electroscope by

We have seen that when a charged body is brought near a leaf electroscope, charges are transferred to the electroscope and the leaf diverges. ***This method of transferring charge without actual contact is called induction.***

Uses of the electroscope

1. To detect the presence of charge on a body
2. To test the quantity of charge on a charge body.
3. To test for insulation properties of a material.
4. To test the sign of charge on a charged body.

Applications of electrostatic charges.

1. *Electrostatic precipitator* – they are used in chimneys to reduce pollution by attracting pollutants through electric ionization which then traps them by use of plates (wire mesh). Finger printing and photocopying uses the same principle.
2. *Spray painting*– as air cruises above the paint droplets acquire similar charges therefore spread out finely due to repulsion. Little paint is then used.

Dangers of electrostatics

As liquid flows through a pipe its molecules get charged due to rubbing against inner surface. If the liquid is flammable then this can cause sparks and explode. The same happens to fuels carried in plastic cans therefore it is advisable to carry fuel in metallic cans to leak out the continuously produced charges.

CHAPTER TEN

CELLS AND SIMPLE CIRCUITS.

Introduction

Work done per unit charge is called electrical potential. Current is the flow of charge. For current to be continuous, potential difference between the two points must be sustained.

Sources of continuous currents.

In this process work is continuously done in moving electrons against a repulsive force. **A device in which the potential difference is sustained is called a cell.** A cell is a source of continuous current. The end of a cell with a **higher potential** (fewer electrons) is called the **positive terminal** while the end with **lower potential** (higher electrons) is called the **negative terminal**.

1. *Chemical sources*

A good example is the **electrochemical cell** where simultaneous oxidation-reduction process occurs between the electrolyte and the electrodes. An external circuit is used to transfer the electrons. Examples of electrochemical cells are the **primary cells** i.e. the **dry cell** and **Daniel**

cell. The reactants must be replaced after supplying a given amount of energy. The second type is the **secondary cell** or storage cell where the chemical reaction is reversible i.e. the **lead-acid battery** and **nickel-cadmium** cell. The third type is the **fuel cell** where chemical energy supplied is continuously converted into electrical energy i.e. **hydrogen-oxygen** cell used in spacecraft.

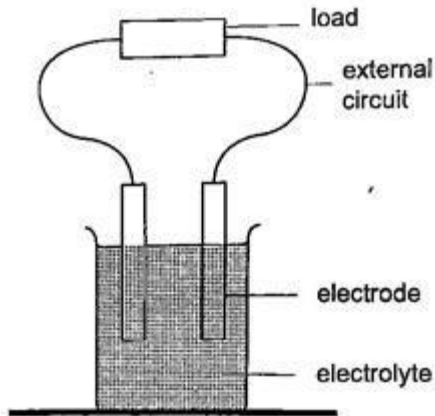

2. Thermoelectric sources

A good example is the thermocouple where p.d is sustained by the continuous heating which keeps the terminals at different temperatures.

3. Solar sources

This occurs when some semi-conductor material called P and N type absorbs light at their transition region and gain energy enough to move electrons just like in cells. They are used in spaceships, calculators, lighting, etc.

DC circuits

Conventionally current is a flow of positive charge and flows from the positive terminal to the negative terminal. A dc current is the flow of current in one direction that is from the positive terminal to the negative terminal when the loop is closed.

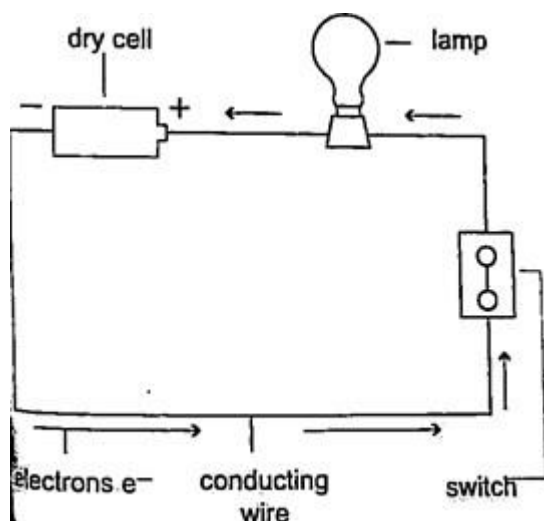

Circuit symbols

The following symbols are used in electrical circuits.

Device	Symbol
Cell	
Battery	
Switch	
Bulb / Filament lamp	
Wires crossing with no connection	
Wires crossing with connection	
Fixed resistor	
Variable resistor	
Potential divider	
Fuse	
Capacitor	
Rheostat	
Ammeter	
Voltmeter	
Galvanometer	

Potential difference and current

Pd is the work done by moving an electron from one point of a conductor to another. Current is by definition the rate of flow of charge.

$$\text{Current} = \text{charge} / \text{time}$$

The SI unit for current is the **ampere, A**.

$$1 \text{ A} = 1 \text{ Coul/sec}$$

$$1 \text{ milliampere (mA)} = 10^{-3} \text{ A}$$

$$1 \text{ microampere (}\mu\text{A)} = 10^{-6} \text{ A}$$

Examples

1. The current in a single loop is 3.0 A. How long would it take for a charge of 3600 coulombs to flow?

Solution

$$\text{Current} = \text{charge} / \text{time}$$

$$\text{Time} = \text{charge} / \text{current} \Rightarrow 3600 / 3 = 1200 \text{ seconds} = 20 \text{ minutes.}$$

- 2.

Primary cells

This is a cell formed by dipping two different metals into an electrolyte.

Experiment: making a simple cell

Procedure

1. Take a piece of copper strip and zinc strip and clean thoroughly with emery paper.
2. Put the two strips in a beaker containing dilute sulphuric acid.
3. Observe what happens to the strips.
4. Connect the strips externally to a milliammeter and a voltmeter.

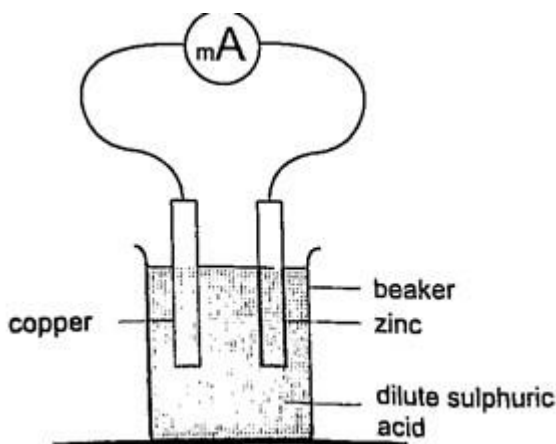

Discussion

Sulphuric acid is chemically written as,

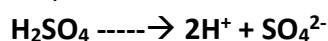

The electrons liberated by the acid move to the zinc electrode

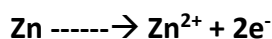

The hydrogen ions move to the copper strip

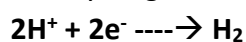

Copper strip therefore becomes positively charged while the zinc becomes negatively charged electrode.

The accumulation of bubbles around the copper strip is called polarization. The bubbles formed around the zinc strip is the reaction of acid with zinc impurities and is called local action. Polarization produces insulation between the strip and the acid cutting off production of current eventually. This is known as the internal resistance of the cell. Local action eats away the zinc strip and a mercury coat is applied to prevent this (amalgamation). Polarization and local action are the main defects of simple cells.

The Leclanche' cell

In this cell **carbon rod** is used as the **positive terminal** and **zinc** as the **negative electrode**. The electrolyte is **ammonium chloride solution (NH₄Cl)**. No polarization since it is reduced by use of **manganese (IV) oxide (MnO₂)** which oxidizes hydrogen into water. Local action still occurs. They are used in operating bells and telephone boxes.

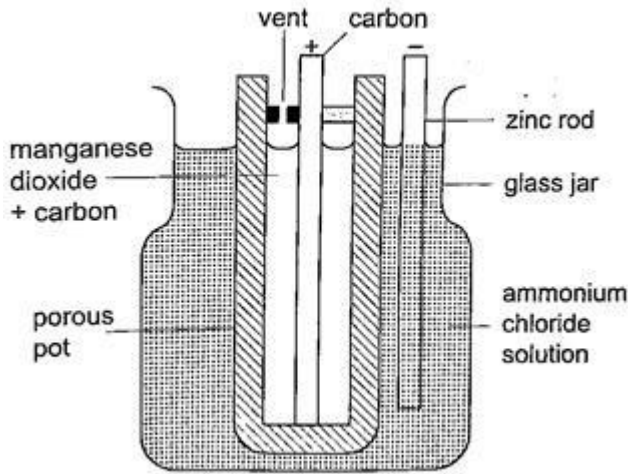

The dry cell

It is referred to as dry because it contains no liquid. The ammonium solution is replaced with **ammonium chloride jelly or paste**, the **manganese (IV) oxide** and **carbon powder** are used as the depolarizer. The hydrogen gas produced is oxidized to water which eventually makes the cell wet after use. They are used in torches, radios calculators etc.

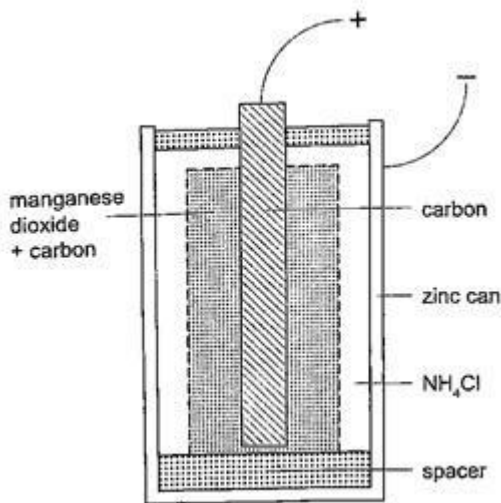

Secondary cells

They are also called storage cells since they store electrical charge as chemical energy.

Experiment: To charge and discharge a simple secondary cell

Procedure

1. Set up the apparatus as shown below.
2. Close the switch S_1 and observe the changes in the plates if any.
3. Note how the ammeter reading varies with time.

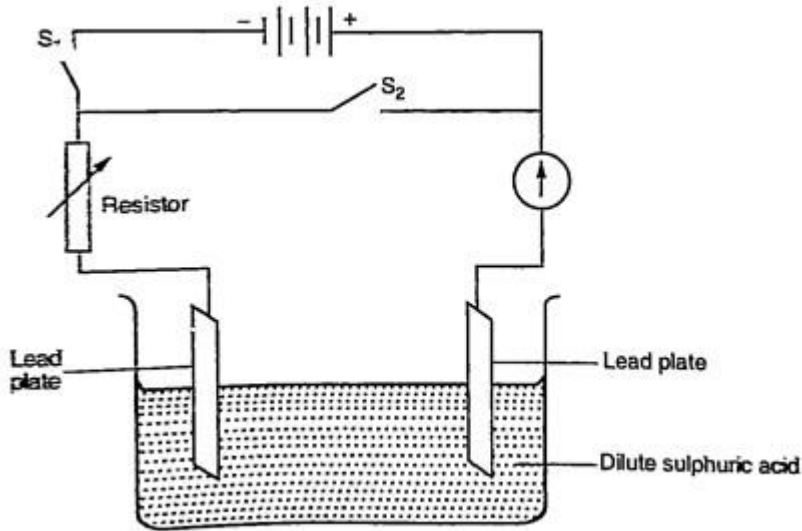

Discussion

When charging **oxygen** is produced at the **anode** and **hydrogen** at the **cathode**. The oxygen reacts with lead to form **lead (IV) oxide** which is deposited at the anode. The hydrogen formed has no effect.

When discharging current flows in opposite direction with oxygen being formed at the cathode and hydrogen at the anode. The colour of the positive electrode changes from brown to grey.

Lead-acid accumulator.

A 12V accumulator has **six cells** connected in **series**. Each cell has several plates forming lattice grid with positive plates carrying **lead (IV) oxide** and the negative plates having **spongy lead**. They are placed close to one another with an insulating sheet separating them. They are rated in **ampere-hours** i.e. 30 Ah means that it can supply 1 ampere for 30 hours or 2 amperes for 15 hours etc.

Example

A battery is rated at 30 Ah. For how long will it work if it steadily supplies a current of 3 A?

Solution

$Q = I t$, hence $t = Q / I \Rightarrow 30 / 3 = 10$ hours.

Alkaline accumulators

Potassium hydroxide (KOH). **Nickel hydroxide (Ni(OH)₂)** forms the positive electrode while iron forms the negative electrode. They are two types **nickel cadmium (NiCd)** and **nickel iron (NiFe)**. They are used in ships, hospitals and buildings where large currents are required for emergencies.

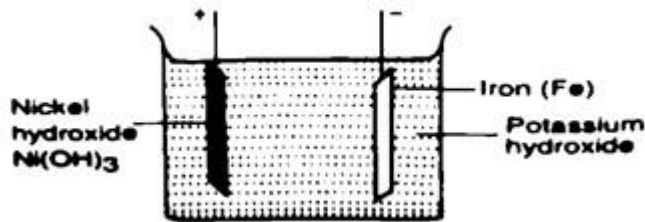

Advantages of alkaline accumulators over lead-acid accumulators

1. Large currents can be drawn from them
2. They require little maintenance
3. They are portable
4. They can remain discharged for a long time without getting ruined.

Disadvantages

1. They are very expensive
2. They have lower e.m.f per cell.