

GENERAL QUESTIONS FOR PRACTICE

1. Suggest one reason why on hot day, heat losses in mains electricity transmission lines may generally be greater than on a cold day.

(1mk)

2. Why is a gap left between one end of a metal bridge and the end of a road leading to the bridge

(1mk)

3. Why does a person weaving dump clothes feel cold on a strong wind

(2mks)

4. A bullet of mass 0.8g traveling at 400m/s is stopped by a concrete wall. Calculate the amount of heat energy transferred to the wall.

(2mks)

5. The figure below shows a uniform metre rule on equilibrium.

(i) What is the significance of the word uniform metre rule

(1mk)

(ii) Determine the weight of the metre rule

(2mks)

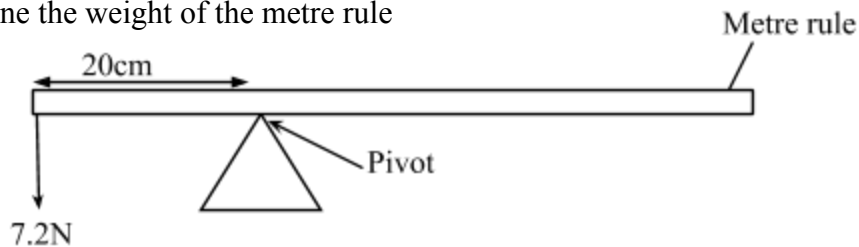

6. An object is projected vertically upwards at a speed of 15ms^{-1} . How long will it take to return to the same level of projection?

(3mks)

7. A boy pulls the handle of a lawn mower at an angle of 30° to the horizontal with a force of 120N. Calculate the work done when the mower moves through a distance of 12.8m.

(3mks)

8. State Hooke's law

(1mk)

9. A force of 20N causes a wire to stretch by 40mm. calculate the energy stored on the 100mm wire when stretched 50mm

(3mks)

10. State **two** ways of increasing the strength of an electromagnet

(2mks)

11. The diagram shows capacitors in parallel connected to 4V battery

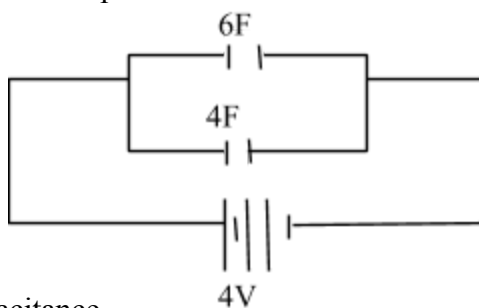

(i) Calculate the total capacitance

(2mks)

(ii) What is the energy stored on the capacitors

(3mks)

12. Show that a body falling from a height h hits the ground with energy $E = \frac{1}{2} mv^2$

(3mks)

13. (a) State Hooke's law

(1mk)

(b) A force of 50N stretches a spring by 60mm. what force will extend by 20mm

(3mks)

(c) Calculate the work required to stretch the spring by 40mm

(3mks)

(d) If the diameter of the spring is 14mm, calculate the stress provided when the force of 100N is applied.

(3mks)

14. A bullet is fired horizontally from a cliff at a velocity 100ms⁻¹. It takes 10 seconds to hit the ground.

(i) Sketch the graph of height against time for the motion

(2mks)

(ii) Calculate the height of the cliff

(2mks)

(iii) What is the horizontal distance moved from the cliff when the bullet hits the ground

(3mks)

(iv) Determine the velocity and direction with which the bullet hits the ground

(3mks)

15. A crane lifts a load of 2000kg through a vertical distance of 3.0m in 6 seconds.

(a) Determine the ;

(i) Work done

(2mks)

(ii) Power developed by the crane

(2mks)

(iii) Efficiency of the crane given that it is operated by an electric motor rated

12.5Kw

(b) In an experiment to determine the specific latent heat of vaporization of water, steam at 100°C was passed into water contained in a well lagged copper calorimeter. The following results were made:

Mass of calorimeter = 50g

Initial mass of water = 70g

Initial temperature of water = 5°C

Final mass of calorimeter + condensed steam = 123g

Final temperature of mixture = 30°C

Specific heat capacity of water = 4200 JKg⁻¹K⁻¹ and specific heat capacity for copper = 390 JKg⁻¹U⁻¹)

Determine the; (a) Mass of condensed steam

(1mk)

(b) Heat gained by the calorimeter

(4mks)

(c) Specific latent heat of vaporization of steam

(3mks)

16. Distinguish between soft and hard magnetic materials

(2mks)

17. (a) Define the following terms ;
 (i) Mechanical advantage
 (ii) Velocity ration
 (iii) Efficiency

(b) Draw a diagram of a pulley system having ;

(i) Velocity ratio of 5

(3mks)

(ii) The pulley system above is used to raise a lead of 100N through a distance of 5cm.

The system is 80% efficient.

Calculate; (i) The effort

(4mks)

(ii) The work done

(3mks)

18. (a) State the principle of moments

(1mk)

(b) A uniform plank of length 6m is pivoted at the centre to make a see saw. A weight of 200N acts at one end. A body weighing 500N moves towards the pivot on the plank as shown.

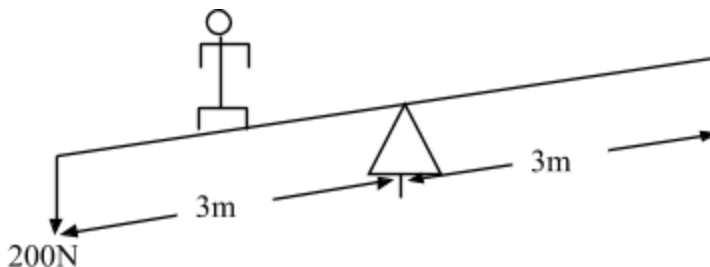

How far will the boy have to move from the pivot, for the see-saw to balance?

(3mks)

19. A string vest keeps a person warm though it is a collection of holes bounded by strings.
Explain

(2mks)

20. Which property of waves explains why sounds are easier to hear at night

(1mk)

21. Three resistors are connected as shown at the figure below.

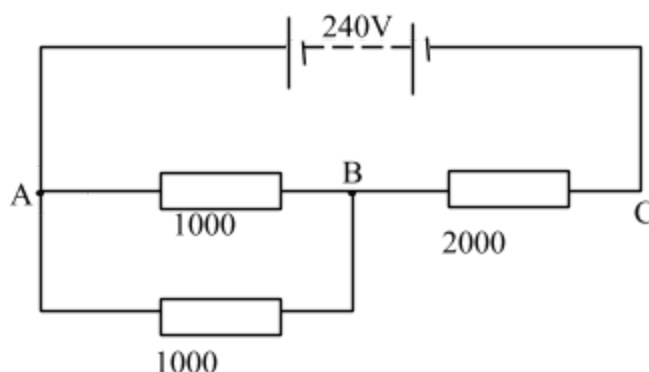

Determine the potential difference between A and B

(3mks)

22. A wise cyclist will carry a load on the bicycle's carrier and not in a rack sack on his back. Explain

(2mks)

23. Give a reason why tungsten is performed as target material in the X-ray tube.

(1mk)

24. An object weighs 0.56N in air and 0.42N when wholly immersed in water. Calculate the density of the object. (Density of water = $1 \times 10^3 \text{kgm}^{-3}$)

(3mks)

25. The conductivity of a metallic conductor decreases with increase in temperature whereas the conductivity of a semi-conductor increases with increase in temperature. Explain

(2mks)

26. Light of frequency $6.0 \times 10^{14} \text{Hz}$ strikes a sodium surface of work function $3.68 \times 10^{-19} \text{J}$. Calculate the maximum energy with which electrons are emitted.

(Planks constant = $6.6 \times 10^{-34} \text{J}$)

(3mks)

27. Use the kinetic theory to explain the behavior of illuminated smoke floating in air

(2mks)

29. Find the quantity of heat required to change ice at -10°C to water at 0°C

(3mks)

30. The pattern below shows oil leakage on a path at the rate of 10 drops per second from a lorry.

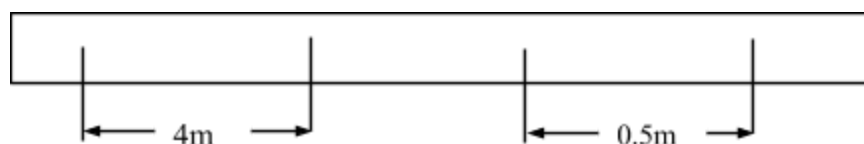

(a) Calculate the initial and final velocity

(3mks)

(b) Calculate the acceleration of the lorry

(2mks)

SECTION 1 – QUESTIONS

Measurement I

1. (a) Distinguish between density and relative density of a substance
 (b) A ship of mass 1300 tonnes floats on sea water:
 - (i) What volume of sea water is displaced (Density of sea water is 1025kg/m^3)
 - (ii) Suppose it sails from sea water to fresh water, what cargo must be removed so that the same volume of water is displaced? (Density of fresh water = 1000kg/m^3)
- (c) Describe an experiment to verify the law of floatation
2. Define **relative density**
3. A bathroom shower has 200 holes each 2.5mm^2 in area. Water flows from a pipe of cross-section area of 15cm^2 at 5m/s to the shower. Determine the speed of the spray.
4. A piece of metal **N** of mass 2kg weighs 18N in water and 12N in liquid **M**. Determine the density of ;
 - (i) The metal **N**
 - (ii) The liquid **M**
5. A measuring cylinder contains 50cm^3 of light oil at 0°C . When a lump of dried ice is placed in the oil, the total volume is 72cm^3 . Determine the density of the ice
 The **figure 1** below shows a manometer connected to a gas supply. The pressure of the gas supply above the atmospheric pressure is equivalent to a 20cm column of water. Use this information and the figure to answer questions 2 and 3.

Force

1. (a) The figure below shows a balloon carrying hydrogen gas 3m^3 of density 0.09kgm^{-3} . The mass of the balloon fabric is 2kg and the density of air is 1.25kgm^{-3}

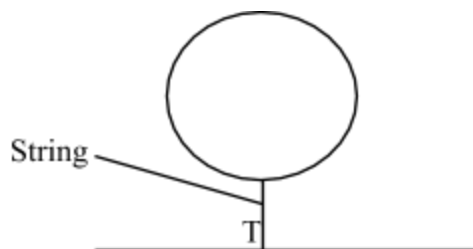

- i) Determine the tension in the string
 - ii) If the string is suddenly cut, calculate the acceleration of the balloon upwards
 - iii) What is the maximum mass of the equipment the balloon can lift at a constant velocity
- b) State and explain **two** features of a hydrometer that make it **sensitive** in its function
2. A block of mass 5kg rests on an inclined surface as shown in the diagram below:

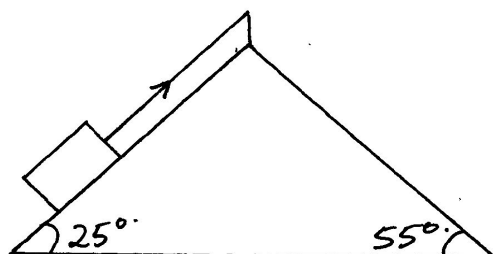

- Determine the static friction on the block
3. State **two** factors that would raise the boiling point of a liquid
 4. Give a reason why water wets glass while mercury does not.
 5. (a) Give an example where force is applied and no work is done

- (b) The graph below shows the variation between force and distance for a boy pushing a concrete block of mass 25kg through a vertically height of 12m .

- (i) Determine the total work done by the boy within 70m
- (ii) How much energy is wasted?
- (iii) Give an account for the energy wasted
- 6. State the principle of moments.
- 7. State any **two** factors that affect the earth's gravitational force
- 8. Figure 3 below string that has been

shows a wire loop with a dipped into soap solution.

Fig. 3

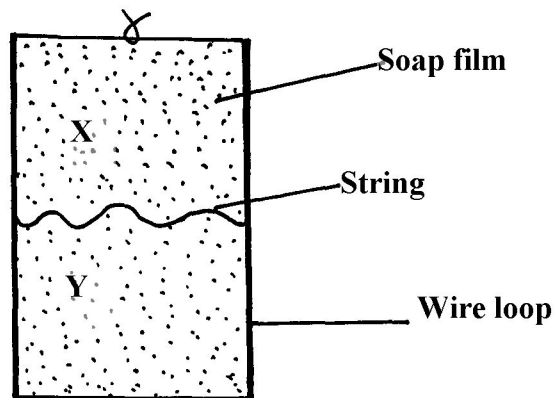

- i) Sketch a similar diagram to show the observed effect if the soap film is punctured at X
- ii) Explain the observations made in (i) above
- 9. **Figure 2** shows two glass tubes of different size of bore, dipped in a glass beaker half full of

water

fig. 2

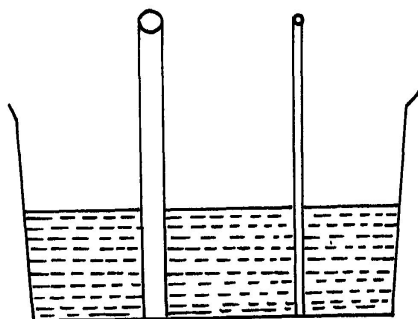

Complete the diagram to show how water will rise up in the two glass tubes

10. (a) State the conditions necessary for the law of conservation of linear momentum to hold
 (b) The diagram **figure 13** below shows a steel ball bearing gently dipped in a viscous liquid contained in a tall cylinder

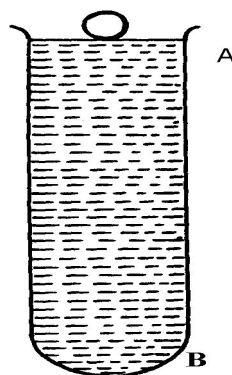

- (i) Name giving their directions the forces acting on the ball bearing as it moves down the cylinder
 (ii) The graph in **figure 14** below shows the velocity-time graph (a) for the motion of the above ball

fig. 14.

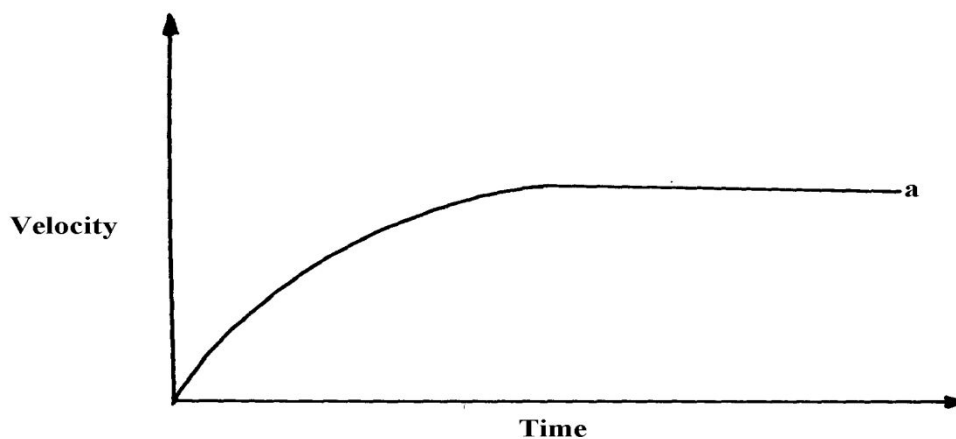

On the same diagram, draw the graph (b) for a steel ball of smaller radius in the same liquid

- (iii) Explain the difference in the two graphs (a) and (b)
 (c) (i) A breakdown truck tows a car of mass 1000kg along a level road, and accelerates at 0.5m/s^2 . What is the tension in the tow line
 (ii) If the tow line in (c)(i) above breaks when the car reaches a speed of 36km/h, how far will the car travel before coming to rest if the breaking force is 2000N?
11. Explain why it is easier to ride a bicycle round a bend on a road if the surface is dry than when it is wet
12. Give **one** difference between limiting and dynamic forces of friction

13. Mercury on a clean glass slide collects into small spherical balls as shown in figure 2 below.

Explain why

Drops of mercury



14. The **figure 7** below shows two blocks of masses $M_1=1.5\text{kg}$ and $M_2= 2.0\text{kg}$ which are in contact on a frictionless table

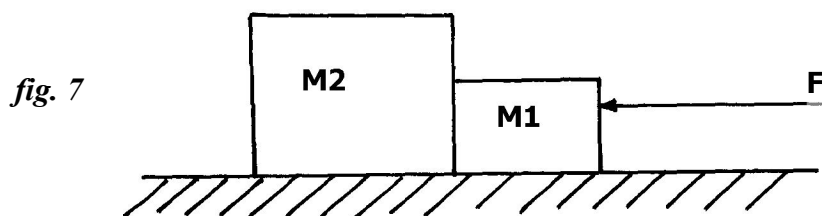

A force $F=7\text{N}$ acts on the bodies, determine the force on mass M_2

15. State **one** factor that determines the depth to which mercury is depressed in a glass capillary tube.

Pressure

1. State the possible reason why, if water is used as a barometer liquid, the glass tube required to hold the column of the liquid is longer
2. State the definition of atmospheric pressure
3. What is the density of alcohol?
4. A person's lung pressure as recorded by a mercury manometer is 90 mm Hg. Express this pressure in SI units.
5. The figure below shows to light pith balls arranged as shown.

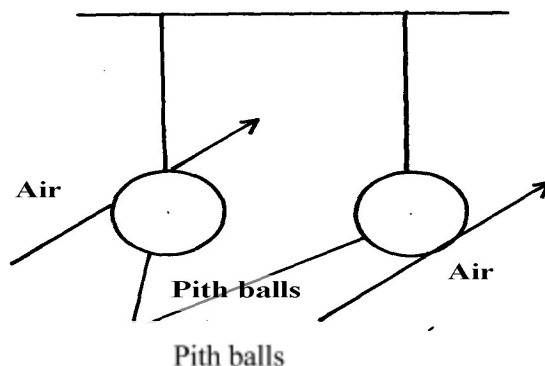

State what is observed air is blown on the outer sides of the pith balls.

7. The barometric height at sea level is 76cm of mercury while at a point on a highland it is 74cm

of mercury. What is the altitude of the point? (Take $g = 10\text{m/s}^2$, density of mercury = 13600kg/m^3 and density of air as 1.25kg/m^3)

8. a) Define specific latent heat of fusion of a substance
b) Water of mass 200g at temperature of 60°C is put in a well lagged copper calorimeter of mass

80g . A piece of ice at 0°C and mass 20g is placed in the calorimeter and the mixture stirred

gently until all the ice melts. The final temperature, T , of the mixture is then measured. Determine:

- The heat absorbed by the melting ice at 0°C
- The heat absorbed by the melted ice (water) to rise to temperature T (answer may be given in terms of T)
- The heat lost by the warm water and the calorimeter (answer may be given in terms of T)
- The final temperature of the mixture

(Specific latent heat of fusion of ice = $334\,000\text{J kg}^{-1}$)

Specific heat capacity of water = $4\,200\text{J kg}^{-1}\text{K}^{-1}$

Specific heat capacity of copper = $900\text{J kg}^{-1}\text{K}^{-1}$)

9. Figure 4 below shows a measuring cylinder of height 30cm filled to a height of 20cm with water and the rest occupied by kerosene

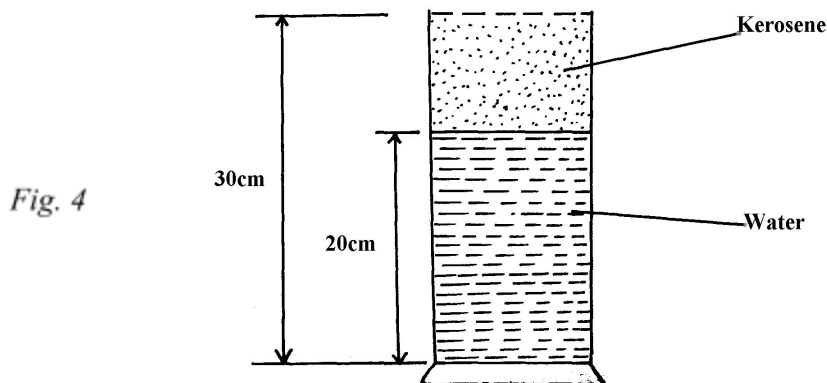

Given that density of water = 1000Kgm^{-3} , density of kerosene = 800Kgm^{-3} and atmospheric

pressure = 1.03×10^5 pascals, determine the pressure acting on the base of the container

- State Pascal's principle of transmission of pressure
- A helical spring extends by 1cm when a force of 1.5N is applied to it. Find the elastic potential energy stored in it.
- Two immiscible liquids are poured in a container to the levels shown in the diagram below.

Figure 5

If the densities of the liquids **A** and **B** are 1g/cm^3 and 0.8g/cm^3 respectively, find the pressure acting upon solid **C** at the bottom of the container due to the liquids

13. Mark the position of the water levels in the manometer when the gas supply is fully turned on
14. Calculate the pressure of the gas supply (Atmospheric pressure = $1.0 \times 10^5 \text{Pa}$)

figure 1

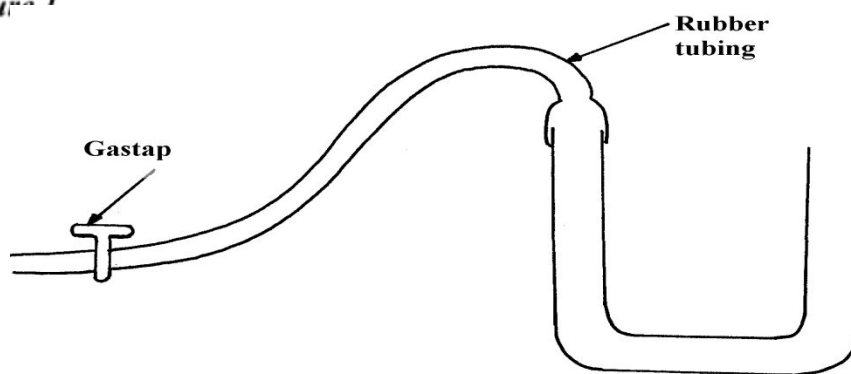

15. A small nail may pierce an inflated car tyre and remain there without pressure reduction in the tyre. Explain the observation
16. (a) State **two** ways of increasing pressure in solids
(b) The figure 1 shows a liquid in a pail

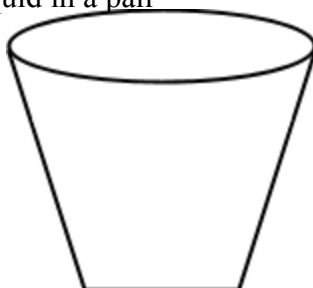

fig. 1

17. Suggest a reason why pail manufacturers prefer the shape shown to other shapes
- Figure 8** shows a funnel inverted over a light ball.

fig. 8

Explain the observation that would be made when streamlines of air is blown strongly down the narrow section of the funnel

18. A block measuring 20cm x 10cm by 5cm rests on a flat surface. The block has a weight of 3N.

Determine the maximum pressure it exerts on the surface.

19. The figure below shows a hydraulic press **P** which is used to raise a load of 10KN. A force

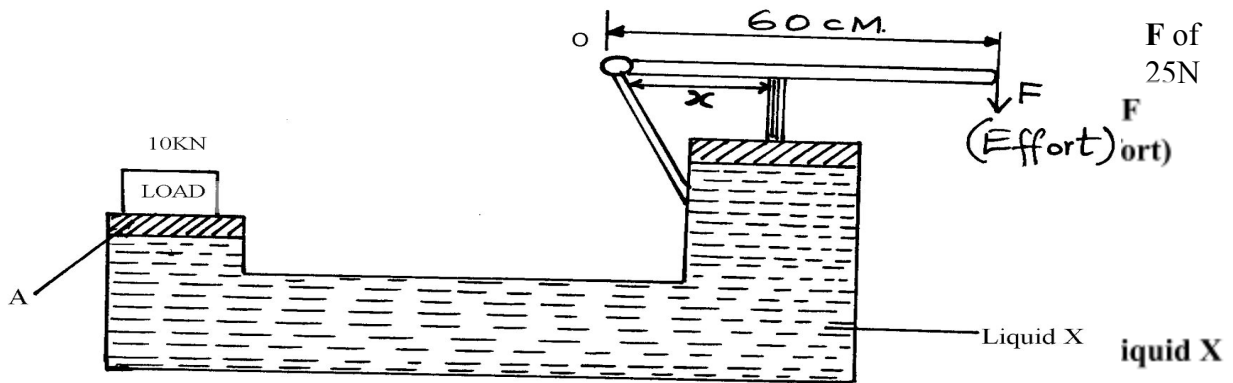

applied at the end of a lever pivoted at O to raise the load

(a) State **one** property of liquid **X**

(b) Determine the distance **x** indicated on the press if force on piston **B** is 100N

19. A mercury –in-glass barometer shows a height of 70cm. What height would be shown in the barometer at the same place if water density $1.0 \times 10^3 \text{kg/m}^3$ is used.
(Density of mercury = 13600kgm^{-3})

20. The total weight of a car with passengers is 25,000N. The area of contact of each of the four tyres with the ground is 0.025m^2 . Determine the minimum car tyre pressure

21. (a) The diagram below represents a u-shaped glass tube sealed at one end and containing mercury

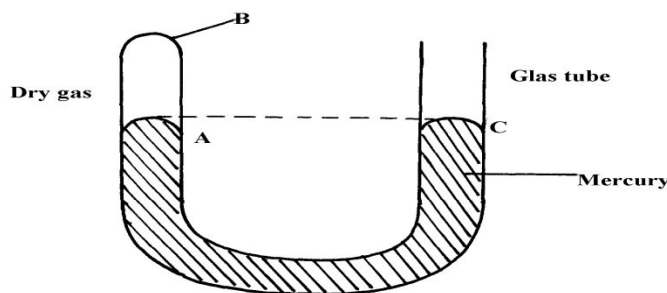

diagram below glass tube sealed containing

(i) What is the pressure of the gas as shown in the diagram above?

(ii) Explain why the gas should be dry if it is to be used to verify a gas law

(iii) Describe how the arrangement can be used to verify Boyle's law.

(b) Use the kinetic theory of gases to explain why;

(i) the pressure of a gas increases with temperature increase

(ii) The pressure of a gas decreases as volume increases

22. The reading on a mercury barometer at Mombasa is 760mm. Calculate the pressure at Mombasa

(density mercury is $1.36 \times 10^4 \text{Kgm}^{-3}$)

23. The figure below is a manometer containing water. Air is blown across the mouth of one tube

and the levels of the water changes as the figure below.



Explain why the level of water in the right limb of manometer is higher.

Current I

1. (a) Distinguish between natural and forced convection currents

 (b) Draw the cross-section of a basic solar heating panel that uses heat from the sun to warm water which flows through pipes
 (b) Explain the following as regards to the solar heater:-
 (i) Why the pipe is made of copper
 (ii) How the green house effect occurs and aids the working of the panel
2. State **two** advantages of generating an alternating current (a.c) to direct current (d.c) in a power station.
3. The table below shows results obtained in an experiment to determine the internal resistance of a cell

V(V)	0.4	0.5	0.6	0.7	08	1.3
R(Ω)	0.45	0.65	0.80	1.05	1.40	2.4
$1/V$ (V^{-1})						
$1/R$ (Ω^{-1})						

- i. Complete the table for values of $1/V$ and $1/R$ giving your answers to 3 d.p
- ii. Plot a graph of $1/V$ against $1/R$

iii. Use the graph to determine the e.m.f \mathcal{E} and the internal resistance r of the cell given that

$$\frac{\mathcal{E}}{V} = \frac{r}{R} + 1$$

(4mks)

Particulate nature of matter

1.
 - (a) State the kinetic theory of matter
 - (b) State **two** reasons why gas particles diffuse faster than solid particles
 - (c) You are provided with a long glass-tube, fitting corks, cotton wool, concentrated solution hydrochloric acid and concentrated ammonia solution.
 - (i) Draw a possible set-up to compare the rates of diffusion of ammonia gas and hydrochloric acid gas
 - (ii) Outline a clear procedure on how the experiment can be carried out
 - (iii) What are the possible observations and conclusion
2. Distinguish between gases and liquids in terms of inter molecule forces.
3. What is the experimental evidence that shows that molecules in gases and liquids are in a state of motion
4. State Newton's second law of motion.
5. Smoke particles in air when strongly illuminated were observed to describe continuous, random

haphazard movements. Explain what would be observed when the air temperature is decreased

6. State how heat transfer by radiation is reduced in a vacuum flask

7. (a) A partially filled balloon is placed in a bell jar with its open end on a thick glass plate as shown

in *figure 16*. The contact between the jar and the glass plate is greased to make it air tight:

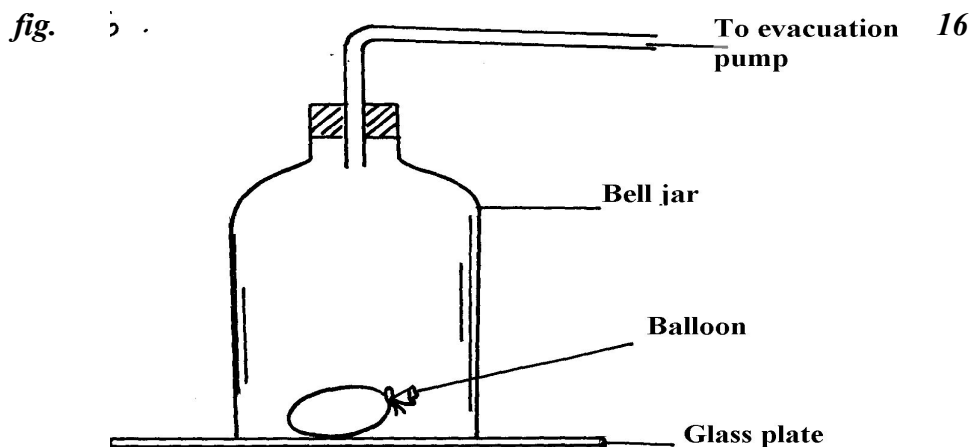

State and explain what happens to the balloon when air in the ball jar is slowly evacuated

(b) *Figure 17* below shows an arrangement to demonstrate diffusion through solids:-
fig. 17

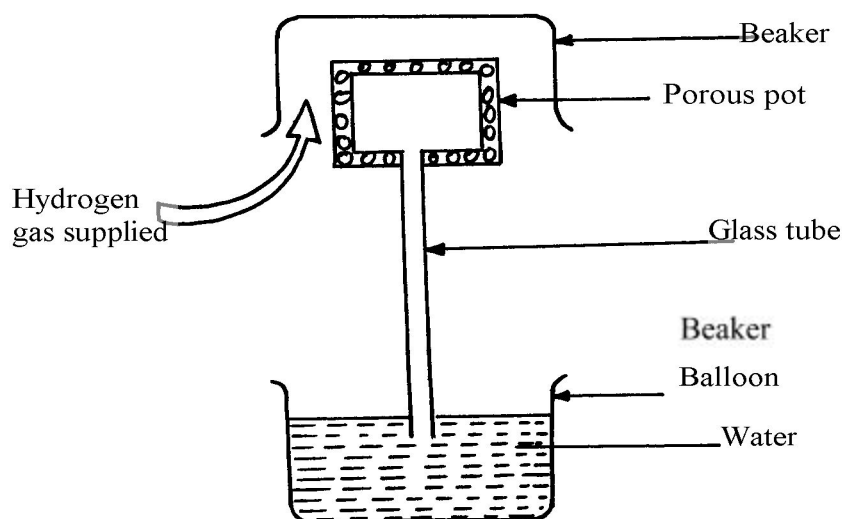

The hydrogen gas is supplied for sometimes then stopped. State and explain what is likely

to be observed when the hydrogen gas supply:-

(i) is on

(ii) is stopped
(c) The diagram fig. 18 shows a glass tube containing enclosed air by a thread of mercury
50mm

long
tube is held in a
horizontal position

when the

fig. 18

Trapped
air

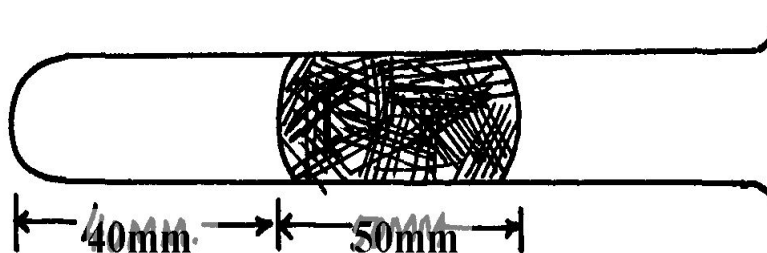

(i) The tube is slowly raised in a vertical position with the open end facing up.

Determine

the new length of the trapped air (tube has same area of cross-section; atmospheric pressure = 750mmHg)

(ii) Account for the difference in the column of trapped air using kinetic theory of matter

assuming that temperature is constant.

8. Two samples of bromine vapour are allowed to diffuse separately under different conditions, one

in a vacuum and the other in air. State with reasons the conditions in which bromine will diffuse

faster

9. In terms of kinetic theory of matter, explain why evaporation causes cooling

10. (a) In an experiment to demonstrate Brownian motion, smoke was placed in air cell and observed

under a microscope. Smoke particles were observed to move randomly in the cell.

(i) Explain the observation

(ii) Give a reason for using small particles such as those of smoke in this experiment

(iii) What would be the most likely observation if the temperature in the smoke cell was raised?

(b) An oil drop of average diameter 0.7mm spreads out into a circular patch of diameter 75cm on the surface of water in a trough

(i) Calculate the average thickness of a molecule of oil

(ii) State **two** assumptions made in (i) above

11. Give a reason why gases are more compressible than liquids

12. Explain the cause of random motion of smoke particles as observed in Brownian motion experiment using a smoke cell.

Thermal expansion

1. Figure 1 shows a beam balance made out of concrete and reinforced with steel

2. Use a diagram to explain the behaviour of the shape of the beam when heated up
 (a) State **two** liquids which are used in thermometer.

(b) With a reason, state which of the two liquids in 3 (a) above is used to measure temperature in

areas where temperatures are:

- (i) below -40°C
- (ii) 150°C

3. What do you understand by the statement 'lower fixed point' on a temperature scale?

4. Name **two** adaptations that can be made to a mercury thermometer to make it more sensitive

5. **Figure 5** shows a bimetallic strip made of brass and iron. A marble is placed at end A of the bimetallic strip as shown below:-

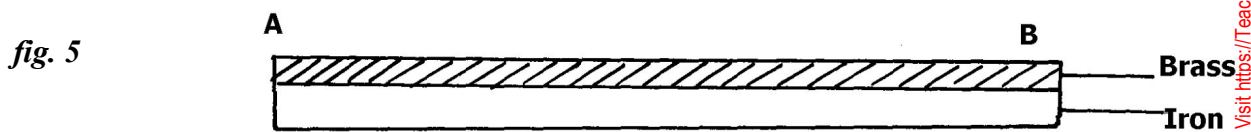

State and explain what will be observed when the bimetallic strip is strongly cooled

6. The figure below represents a bimetallic strip of metals X and Y at room temperature

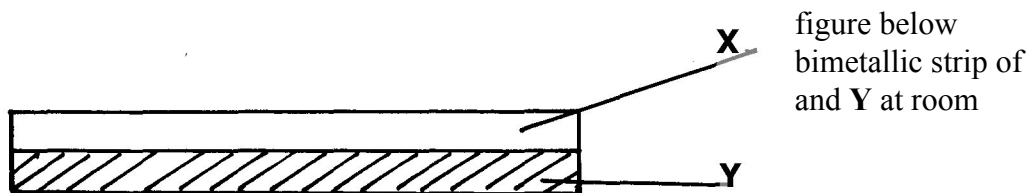

The figure below shows its shape when dipped into crushed ice

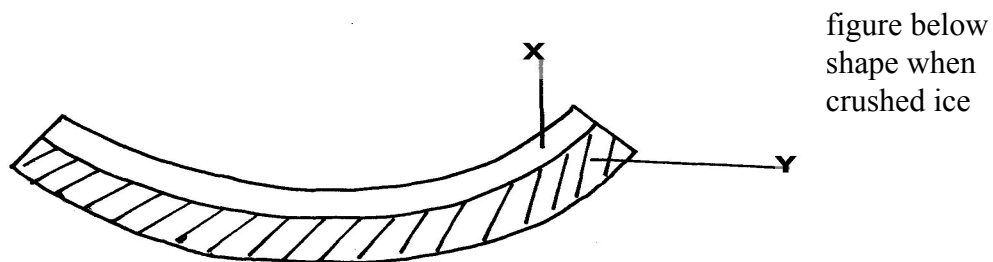

Sketch a diagram in the space given below to show the shape when the strip is heated to a temperature above the room temperature

7. Give a reason why a concrete beam reinforced with steel does not crack when subjected to Changes in temperature.