

PHYSICS FORM THREE

CHAPTER ONE LINEAR MOTION

Introduction

Study of motion is divided into two;

1. Kinematics
2. Dynamics

In kinematics forces causing motion are disregarded while dynamics deals with motion of objects and the forces causing them.

I. Displacement

Distance moved by a body in a specified direction is called displacement. It is denoted by letter 's' and has both magnitude and direction. Distance is the movement from one point to another. The SI unit for displacement is the **metre (m)**.

II. Speed

This is the distance covered per unit time.

Speed= distance covered/ time taken. Distance is a scalar quantity since it has magnitude only. The SI unit for speed is **metres per second (m/s or ms⁻¹)**

Average speed= total distance covered/total time taken

Other units for speed used are **Km/h**.

Examples

1. A body covers a distance of 10m in 4 seconds. It rests for 10 seconds and finally covers a distance of 90m in 60 seconds. Calculate the average speed.

Solution

$$\text{Total distance covered}=10+90=100\text{m}$$

$$\text{Total time taken}=4+10+6=20 \text{ seconds}$$

$$\text{Therefore average speed}=100/20=5\text{m/s}$$

2. Calculate the distance in metres covered by a body moving with a uniform speed of 180 km/h in 30 seconds.

Solution

$$\begin{aligned}\text{Distance covered}&=\text{speed}\times\text{time} \\ &=180\times 1000/60\times 60=50\text{m/s} \\ &=50\times 30 \\ &=1,500\text{m}\end{aligned}$$

3. Calculate the time in seconds taken a by body moving with a uniform speed of 360km/h to cover a distance of 3,000 km?

Solution

$$\text{Speed: } 360 \text{ km/h}=360\times 1000/60\times 60=100\text{m/s}$$

$$\begin{aligned}\text{Time}&=\text{distance/speed} \\ &=3000\times 1000/100 \\ &=30,000 \text{ seconds.}\end{aligned}$$

III. Velocity

This is the change of displacement per unit time. It is a vector quantity.

Velocity=change in displacement/total time taken

The SI units for velocity are **m/s**

Examples

1. A man runs 800m due North in 100 seconds, followed by 400m due South in 80 seconds. Calculate,
 - a. His average speed
 - b. His average velocity
 - c. His change in velocity for the whole journey

Solution

- a. Average speed: total distance travelled/total time taken

$$= \frac{800+400}{100+80}$$

$$= \frac{1200}{180}$$

$$= 6.67 \text{ m/s}$$
 - b. Average velocity: total displacement/total time

$$= \frac{800-400}{180}$$

$$= \frac{400}{180}$$

$$= 2.22 \text{ m/s due North}$$
 - c. Change in velocity = final - initial velocity

$$= \left(\frac{800}{100}\right) - \left(\frac{400}{80}\right)$$

$$= 8 - 5$$

$$= 3 \text{ m/s due North}$$
2. A tennis ball hits a vertical wall at a velocity of 10m/s and bounces off at the same velocity. Determine the change in velocity.

Solution

Initial velocity (u) = -10m/s

Final velocity (v) = 10m/s

Therefore change in velocity = v - u

$$= 10 - (-10)$$

$$= 20 \text{ m/s}$$

IV. Acceleration

This is the change of velocity per unit time. It is a vector quantity symbolized by 'a'.

Acceleration 'a' = change in velocity/time taken = $v - u / t$

The SI units for acceleration are m/s^2

Examples

1. The velocity of a body increases from 72 km/h to 144 km/h in 10 seconds. Calculate its acceleration.

Solution

Initial velocity = 72 km/h = 20m/s

Final velocity = 144 km/h = 40m/s

Therefore 'a' = $v - u / t$

$$= \frac{40 - 20}{10}$$

$$2 \text{ m/s}^2$$

2. A car is brought to rest from 180km/h in 20 seconds. What is its retardation?

Solution

Initial velocity = 180km/h = 50m/s

Final velocity = 0 m/s

A = $v - u / t = 0 - 50 / 20$

$$= -2.5 \text{ m/s}^2$$

Hence retardation is 2.5 m/s^2

Motion graphs

Distance-time graphs

a)

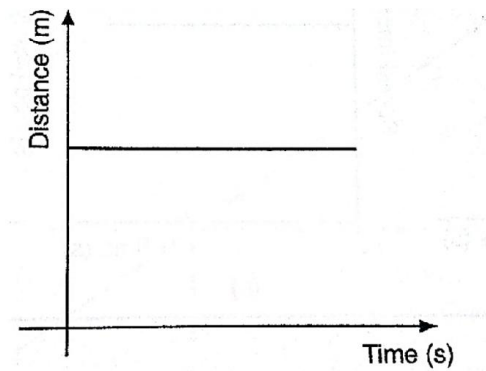

Stationary body

b)

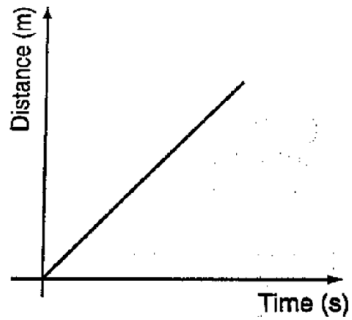

A body moving with uniform speed

c)

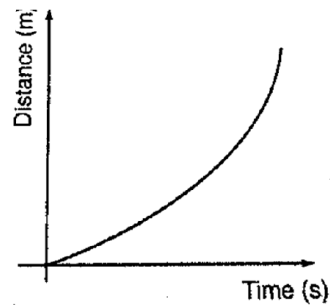

A body moving with variable speed

Area under velocity-time graph

Consider a body with uniform or constant acceleration for time 't' seconds;

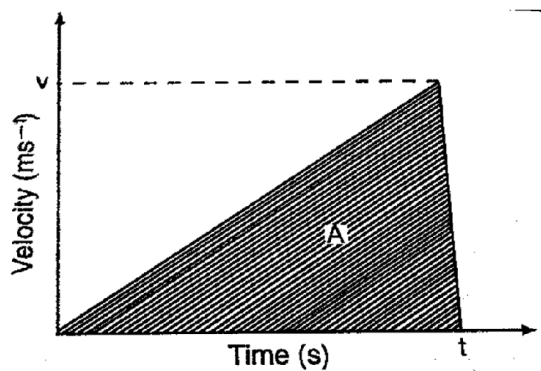

Generated by CamScanner

$$\begin{aligned} \text{Distance travelled} &= \text{average velocity} \times t \\ &= (0+v/2) \times t \\ &= 1/2vt \end{aligned}$$

This is equivalent to the area under the graph. The area under velocity-time graph gives the distance covered by the body under 't' seconds.

Example

A car starts from rest and attains a velocity of 72km/h in 10 seconds. It travels at this velocity for 5 seconds and then decelerates to stop after another 6 seconds. Draw a velocity-time graph for this motion. From the graph;

- Calculate the total distance moved by the car
- Find the acceleration of the car at each stage.

Solution

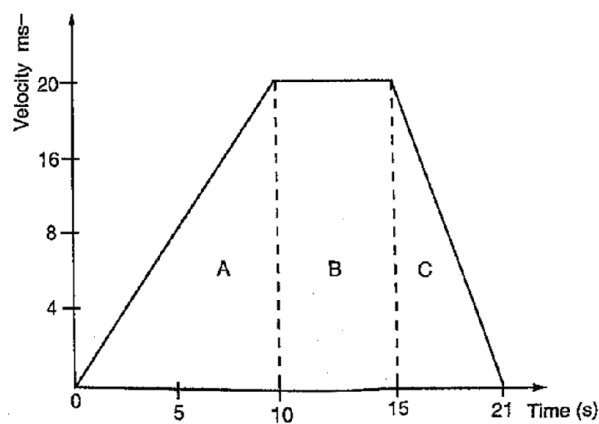

- From the graph, total distance covered = area of (A+B+C)

$$\begin{aligned} &= (1/2 \times 10 \times 20) + (1/2 \times 6 \times 20) + (5 \times 20) \\ &= 100 + 60 + 100 \\ &= 260\text{m} \end{aligned}$$

Also the area of the trapezium gives the same result.

- Acceleration = gradient of the graph

Stage A gradient= $20-0/10-0 = 2 \text{ m/s}^2$
 Stage b gradient= $20-20/15-10 = 0 \text{ m/s}^2$
 Stage c gradient= $0-20/21-15 = -3.33 \text{ m/s}^2$

Using a ticker-timer to measure speed, velocity and acceleration.

It will be noted that the dots pulled at different velocities will be as follows;

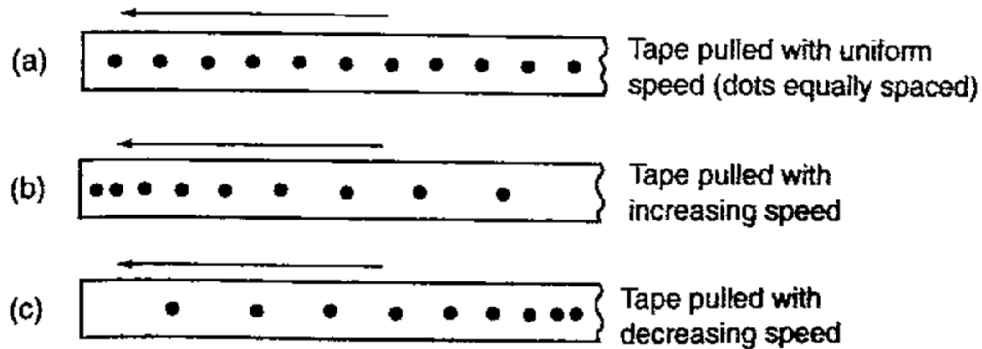

Most ticker-timers operate at a frequency of **50Hz** i.e. *50 cycles per second* hence they make 50 dots per second. Time interval between two consecutive dots is given as,

$1/50 \text{ seconds} = 0.02 \text{ seconds}$. This time is called a tick.

The distance is measured in ten-tick intervals hence time becomes $10 \times 0.02 = 0.2 \text{ seconds}$.

Examples

- a. A tape is pulled steadily through a ticker-timer of frequency 50 Hz. Given the outcome below, calculate the velocity with which the tape is pulled.

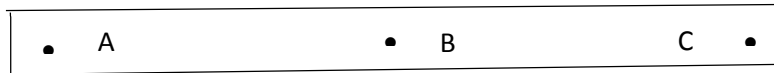

Solution

Distance between two consecutive dots= 5cm

Frequency of the ticker-timer=50Hz

Time taken between two consecutive dots= $1/50=0.02 \text{ seconds}$

Therefore, velocity of tape= $5/0.02 = 250 \text{ cm/s}$

- b. The tape below was produced by a ticker-timer with a frequency of 100Hz. Find the acceleration of the object which was pulling the tape.

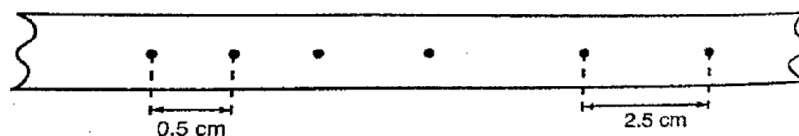

Solution

Time between successive dots = $1/100 = 0.01$ seconds

Initial velocity (u) $0.5/0.01 = 50$ cm/s

Final velocity (v) $2.5/0.01 = 250$ cm/s

Time taken = $4 \times 0.01 = 0.04$ seconds

Therefore, acceleration = $v - u / t = 250 - 50 / 0.04 = 5,000$ cm/s²

Equations of linear motion

The following equations are applied for uniformly accelerated motion;

$$v = u + at$$

$$s = ut + \frac{1}{2} at^2$$

$$v^2 = u^2 + 2as$$

Examples

1. A body moving with uniform acceleration of 10 m/s^2 covers a distance of 320 m . if its initial velocity was 60 m/s . Calculate its final velocity.

Solution

$$v^2 = u^2 + 2as$$

$$= (60)^2 + 2 \times 10 \times 320$$

$$= 3600 + 6400$$

$$= 10,000$$

$$\text{Therefore } v = (10,000)^{1/2}$$

$$v = 100 \text{ m/s}$$

2. A body whose initial velocity is 30 m/s moves with a constant retardation of 3 m/s^2 . Calculate the time taken for the body to come to rest.

Solution

$$v = u + at$$

$$0 = 30 - 3t$$

$$30 = 3t$$

$$t = 30 \text{ seconds.}$$

3. A body is uniformly accelerated from rest to a final velocity of 100 m/s in 10 seconds. Calculate the distance covered.

Solution

$$s = ut + \frac{1}{2} at^2$$

$$= 0 \times 10 + \frac{1}{2} \times 10 \times 10^2$$

$$= 1000/2 = 500 \text{ m}$$

Motion under gravity.

1. Free fall

The equations used for constant acceleration can be used to become,

$$v = u + g t$$

$$s = ut + \frac{1}{2} g t^2$$

$$v^2 = u^2 + 2gs$$

2. Vertical projection

Since the body goes against force of gravity then the following equations hold

$$v = u - g t \dots\dots\dots 1$$

$$s = ut - \frac{1}{2} g t^2 \dots\dots 2$$

$$v^2 = u - 2gs \dots\dots\dots 3$$

N.B time taken to reach maximum height is given by the following

$$t = u/g \text{ since } v=0 \text{ (using equation 1)}$$

Time of flight

The time taken by the projectile is the time taken to fall back to its point of projection.

Using eq. 2 then, displacement =0

$$0 = ut - \frac{1}{2} g t^2$$

$$0 = 2ut - g t^2$$

$$t (2u - g t) = 0$$

$$\text{Hence, } t=0 \text{ or } t = 2u/g$$

t=0 corresponds to the start of projection

$t = 2u/g$ corresponds to the time of flight

The time of flight is twice the time taken to attain maximum height.

Maximum height reached.

Using equation 3 maximum height, H_{max} is attained when $v=0$ (final velocity). Hence

$$v^2 = u^2 - 2gs; \text{ - } 0 = u^2 - 2gH_{max}, \text{ therefore}$$

$$2gH_{max} = u^2$$

$$H_{max} = u^2/2g$$

Velocity to return to point of projection.

At the instance of returning to the original point, total displacement equals to zero.

$$v^2 = u^2 - 2gs \text{ hence } v^2 = u^2$$

$$\text{Therefore } v = u \text{ or } v = \pm u$$

Example

A stone is projected vertically upwards with a velocity of 30m/s from the ground.

Calculate,

- a. The time it takes to attain maximum height
- b. The time of flight
- c. The maximum height reached
- d. The velocity with which it lands on the ground. (take $g=10m/s$)

Solution

- a. Time taken to attain maximum height

$$T = u/g = 30/10 = 3 \text{ seconds}$$

- b. The time of flight

$$T = 2t = 2 \times 3 = 6 \text{ seconds}$$

$$\text{Or } T = 2u/g = 2 \times 30/10 = 6 \text{ seconds.}$$

- c. Maximum height reached

$$H_{\max} = u^2/2g = 30 \times 30 / 2 \times 10 = 45\text{m}$$

d. Velocity of landing (return)

$$v^2 = u^2 - 2gs, \text{ but } s=0,$$

$$\text{Hence } v^2 = u^2$$

$$\text{Therefore } v = (30 \times 30)^{1/2} = 30\text{m/s}$$

3. Horizontal projection

The path followed by a body (projectile) is called trajectory. The maximum horizontal distance covered by the projectile is called range.

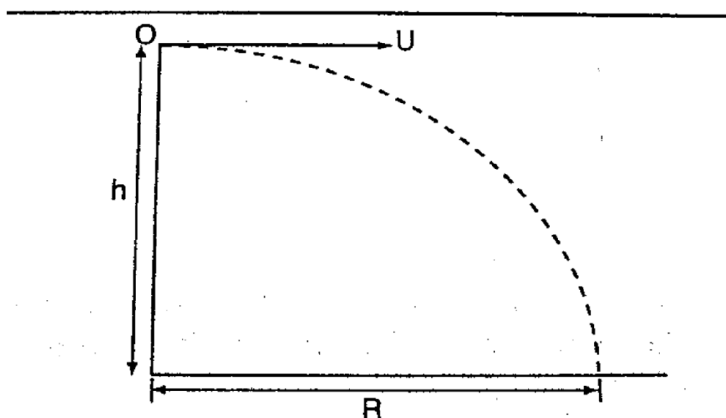

The horizontal displacement 'R' at a time 't' is given by $s = ut + \frac{1}{2}at^2$

Taking $u = u$ and $a = 0$ hence $R = u t$, is the horizontal displacement and $h = \frac{1}{2}gt^2$ is the vertical displacement.

NOTE

The time of flight is the same as the time of free fall.

Example

A ball is thrown from the top of a cliff 20m high with a horizontal velocity of 10m/s. Calculate,

- The time taken by the ball to strike the ground
- The distance from the foot of the cliff to where the ball strikes the ground.
- The vertical velocity at the time it strikes the ground. (take $g = 10\text{m/s}^2$)

Solution

a. $h = \frac{1}{2}gt^2$

$$20 = \frac{1}{2} \times 10 \times t^2$$

$$40 = 10t^2$$

$$t^2 = 40/10 = 4$$

$$t = 2 \text{ seconds}$$

b. $R = u t$

$$= 10 \times 2$$

$$= 20\text{m}$$

c. $v = u + a t = g t$

$$= 2 \times 10 = 20\text{m/s}$$

CHAPTER TWO REFRACTION OF LIGHT

Introduction

Refraction is the change of direction of light rays as they pass at an angle from one medium to another of different optical densities.

Exp. To investigate the path of light through rectangular glass block.

Apparatus: - soft-board, white sheet of paper, drawing pins (optical), rectangular glass block.

Procedure

1. Fix the white plain paper on the soft board using pins.
2. Place the glass block on the paper and trace its outline, label it ABCD as shown below.
3. Draw a normal NON at point O.
4. Replace the glass block to its original position.
5. Stick two pins P_1 and P_2 on the line such that they are at least 6cm apart and upright.
6. Viewing pins P_1 and P_2 from opposite side, fix pins P_3 and P_4 such that they're in a straight line.
7. Remove the pins and the glass block.
8. Draw a line joining P_3 and P_4 and produce it to meet the outline face AB at point O

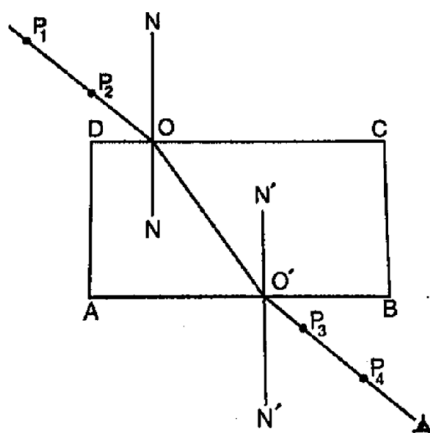

Explanation of refraction.

Light travels at a velocity of 3.0×10^8 in a vacuum. Light travels with different velocities in different media. *When a ray of light travels from an optically less dense media to more dense media, it is refracted towards the normal.* The glass block experiment gives rise to a very important law known as **the law of reversibility** which states that **“if a ray of light is reversed, it always travels along its original path”**. If the glass block is parallel-sided, the emergent ray will be parallel to the incident ray but displaced laterally as shown

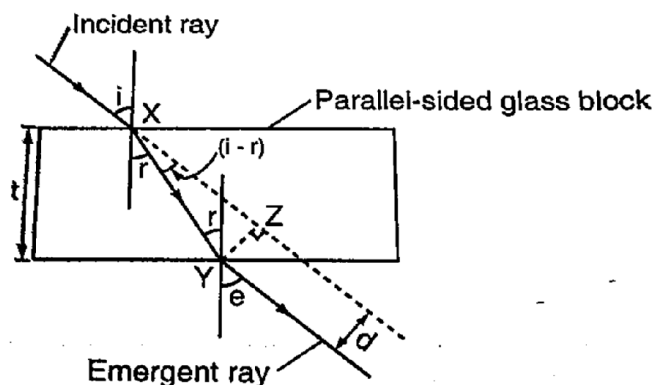

'e' is called the angle of emergence. The direction of the light is not altered but displaced sideways. This displacement is called lateral displacement and is denoted by 'd'. Therefore

$$XY = t / \cos r \quad YZ = \sin(i - r) \times XY$$

So, lateral displacement, $d = t \sin(i - r) / \cos r$

Laws of refraction

1. The incident ray, the refracted ray and the normal at the point of incidence all lie on the same plane.
2. The ratio of the sine of the angle of incidence to the sine of the angle of refraction is a constant for a given pair of media.

$$\sin i / \sin r = \text{constant } (k)$$

Refractive index

Refractive index (n) is the constant of proportionality in Snell's law; hence

$$\sin i / \sin r = n$$

Therefore $\sin i / \sin r = n = 1 / \sin r / \sin i$

Examples

1. Calculate the refractive index for light travelling from glass to air given that ${}_a n_g = 1.5$

Solution

$${}_g n_a = 1 / {}_a n_g = 1 / 1.5 = 0.67$$

2. Calculate the angle of refraction for a ray of light from air striking an air-glass interface, making an angle of 60° with the interface. (${}_a n_g = 1.5$)

Solution

$$\text{Angle of incidence } (i) = 90^\circ - 60^\circ = 30^\circ$$

$$1.5 = \sin 30^\circ / \sin r, \sin r = \sin 30^\circ / 1.5 = 0.5 / 1.5$$

$$\sin r = 0.3333, \sin^{-1} 0.3333 = 19.5^\circ$$

$$R = 19.5^\circ$$

Refractive index in terms of velocity.

Refractive index can be given in terms of velocity by the use of the following equation;

$${}_1n_2 = \text{velocity of light in medium 1} / \text{velocity of light in medium 2}$$

When a ray of light is travelling from vacuum to a medium the refractive index is referred to as absolute refractive index of the medium denoted by 'n'

Refractive index of a material 'n' = velocity of light in a vacuum / velocity of light in material 'n'

The absolute refractive indices of some common materials is given below

	Material	Refractive index
1	Air (ATP)	1.00028
2	Ice	1.31
3	Water	1.33
4	Ethanol	1.36
5	Kerosene	1.44
6	Glycerol	1.47
7	Perspex	1.49
8	Glass (crown)	1.55
9	Glass (flint)	1.65
10	Ruby	1.76
11	Diamond	2.72

Examples

1. A ray of light is incident on a water-glass interface as shown. Calculate 'r'. (Take the refractive index of glass and water as 3/2 and 4/3 respectively)

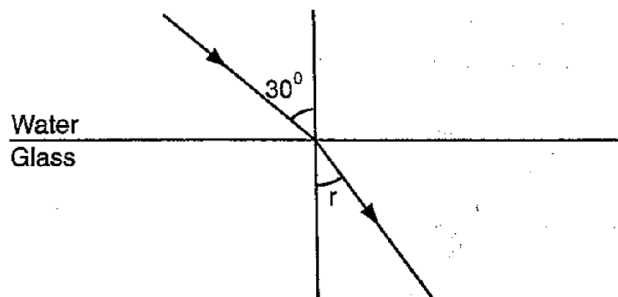

Solution

$$\text{Since } {}_a n_w \sin \theta_w = {}_a n_g \sin r$$

$$4/3 \sin 30^\circ = 3/2 \sin r$$

$$3/2 \sin r = 4/3 \times 0.5$$

$$\sin r = 4/6 \times 2/3 = 4/9 = 0.4444$$

$$r = 26.4^\circ$$

2. The refractive index of water is 4/3 and that of glass is 3/2. Calculate the refractive index of glass with respect to water.

Solution

$${}_w n_g = {}_g n_a \times {}_a n_g, \text{ but } {}_w n_a = 1 / {}_a n_w = 3/4$$

$${}_w n_g = \frac{3}{4} \times \frac{3}{2} = \frac{9}{8} = 1.13$$

Real and apparent depth

Consider the following diagram

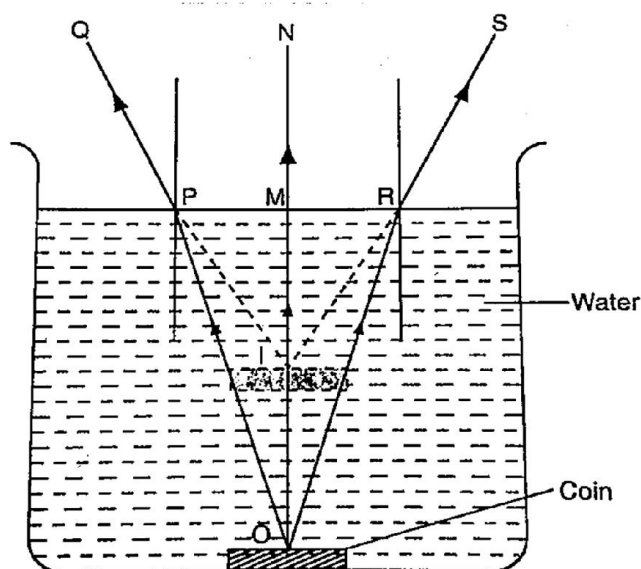

The depth of the water OM is the real depth, and the distance IM is known as the apparent depth. OI is the distance through which the coin has been displaced and is known as the vertical displacement. The relationship between refractive index and the apparent depth is given by;

$$\text{Refractive index of a material} = \frac{\text{real depth}}{\text{apparent depth}}$$

NB

This is true only if the object is viewed normally.

Example

A glass block of thickness 12 cm is placed on a mark drawn on a plain paper. The mark is viewed normally through the glass. Calculate the apparent depth of the mark and hence the vertical displacement. (Refractive index of glass = $\frac{3}{2}$)

Solution

$${}_a n_g = \frac{\text{real depth}}{\text{apparent depth}}$$

$$\text{apparent depth} = \frac{\text{real depth}}{{}_a n_g} = \frac{12 \times 2}{3} = 8 \text{ cm}$$

$$\text{vertical displacement} = 12 - 8 = 4 \text{ cm}$$

Applications of refractive index

Total internal reflection

This occurs when light travels from a denser optical medium to a less dense medium. The refracted ray moves away from the normal until a critical angle is reached usually 90° where the refracted ray is parallel to the boundary between the two media. If this critical angle is

exceeded total internal reflection occurs and at this point no refraction occurs but the ray is reflected internally within the denser medium.

Relationship between the critical angle and refractive index.

Consider the following diagram

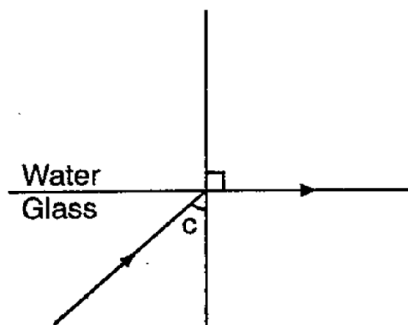

From Snell's law

$${}_g n_w = \frac{\sin C}{\sin 90^\circ}, \text{ but } {}_a n_g = \frac{1}{{}_g n_a} \text{ since } \sin 90^\circ = 1$$

$$\text{Therefore } {}_a n_g = \frac{1}{\sin C}, \text{ hence } \sin C = \frac{1}{n} \text{ or } n = \frac{1}{\sin C}$$

Example

Calculate the critical angle of diamond given that its refractive index is 2.42

Solution

$$\sin C = \frac{1}{n} = \frac{1}{2.42} = 0.4132 = 24.4^\circ$$

Effects of total internal reflection

1. **Mirage:** These are 'pools of water' seen on a tarmac road during a hot day. They are also observed in very cold regions but the light curves in opposite direction such that a polar bear seems to be upside down in the sky.
2. **Atmospheric refraction:** the earth's atmosphere refracts light rays so that the sun can be seen even when it has set. Similarly the sun is seen before it actually rises.

Applications of total internal reflection

1. **Periscope:** a prism periscope consists of two right angled glass prisms of angles $45^\circ, 90^\circ$ and 45° arranged as shown below. They are used to observe distant objects.

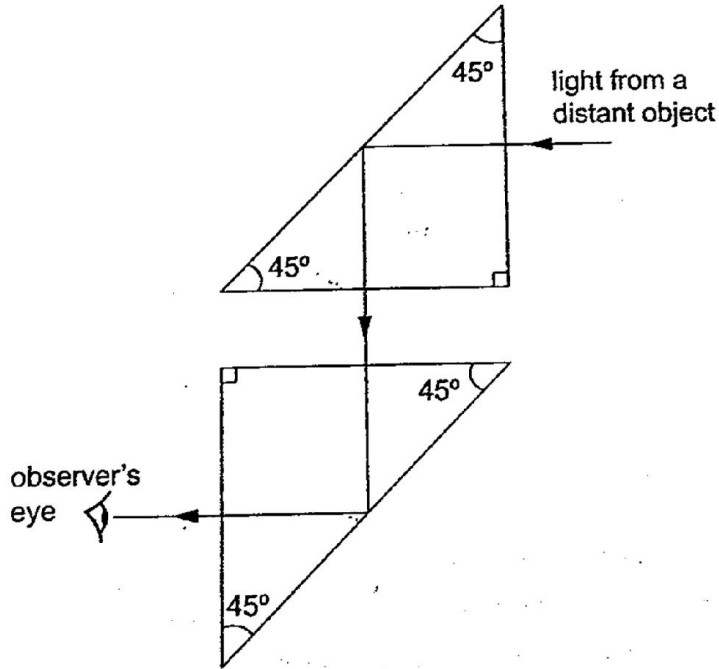

2. **Prism binoculars:** the arrangement of lenses and prisms is as shown below. Binoculars reduce the distance of objects such that they seem to be nearer.

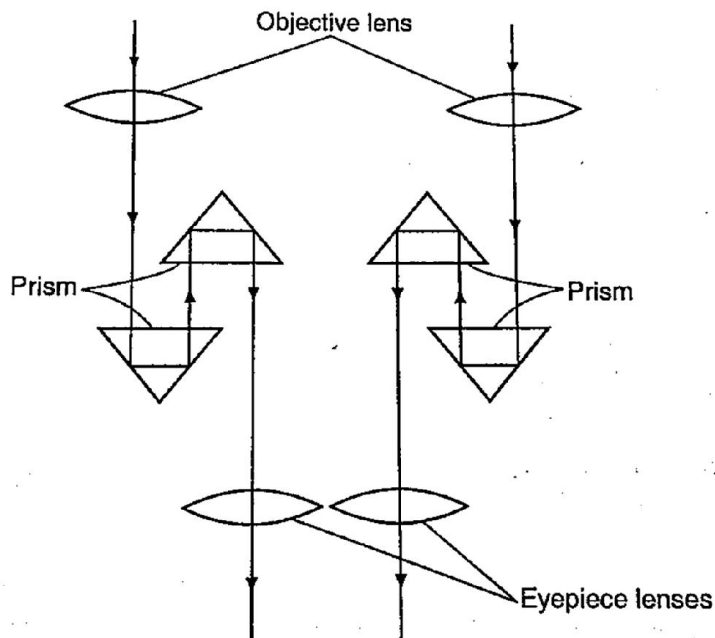

3. **Pentaprism:** used in cameras to change the inverted images formed into erect and actual image in front of the photographer.

4. **Optical fibre:** this is a flexible glass rod of small diameter. A light entering through them undergoes repeated internal reflections. They are used in medicine to observe or view internal organs of the body

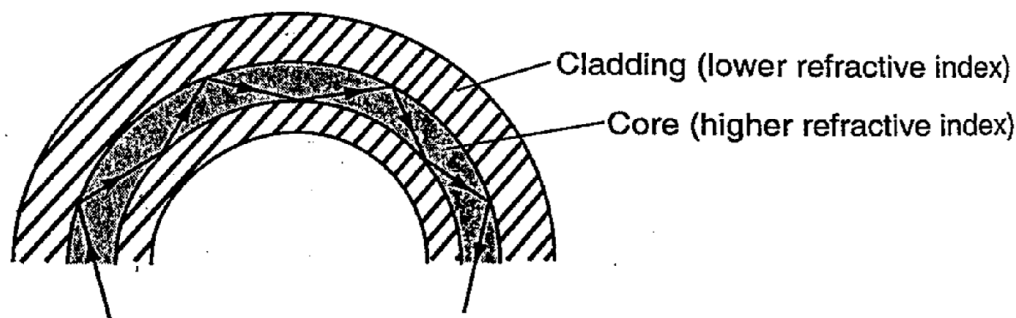

5. **Dispersion of white light:** the splitting of light into its constituent colours is known as dispersion. Each colour represents a different wavelength as they strike the prism and therefore refracted differently as shown.

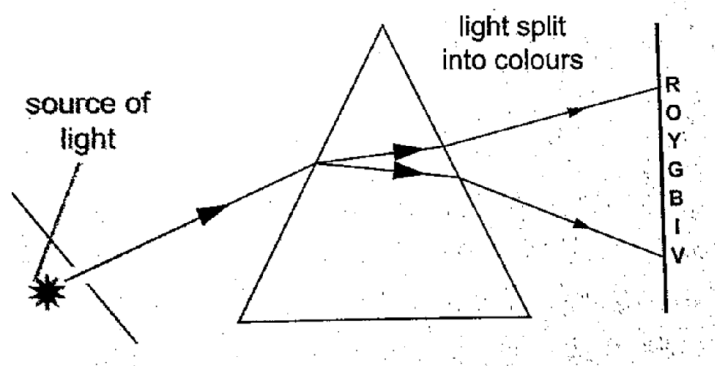

CHAPTER THREE

NEWTON'S LAWS OF MOTION

Newton's first law (law of inertia)

This law states that **"A body continues in its state of rest or uniform motion unless an unbalanced force acts on it"**. The mass of a body is a measure of its inertia. Inertia is the property that keeps an object in its state of motion and resists any efforts to change it.

Newton's second law (law of momentum)

Momentum of a body is defined as the product of its mass and its velocity.

Momentum 'p'=mv. The SI unit for momentum is **kgm/s** or **Ns**. The Newton's second law states that **"The rate of change of momentum of a body is proportional to the applied force and takes place in the direction in which the force acts"**

Change in momentum= **mv-mu**

Rate of change of momentum= **mv-mu/Δt**

Generally the second law gives rise to the equation of force **F=ma**

Hence $F = mv - mu / \Delta t$ and $F \Delta t = mv - mu$

The quantity $F \Delta t$ is called impulse and is equal to the change of momentum of the body. The SI unit for impulse is **Ns**.

Examples

1. A van of mass 3 metric tons is travelling at a velocity of 72 km/h. Calculate the momentum of the vehicle.

Solution

$$\begin{aligned} \text{Momentum} &= mv = 72 \text{ km/h} = (20 \text{ m/s}) \times 3 \times 10^3 \text{ kg} \\ &= 6.0 \times 10^4 \text{ kgm/s} \end{aligned}$$

2. A truck weighs $1.0 \times 10^5 \text{ N}$ and is free to move. What force will give it an acceleration of 1.5 m/s^2 ? (take $g = 10 \text{ N/kg}$)

Solution

$$\text{Mass of the truck} = (1.0 \times 10^5) / 10 = 6.0 \times 10^4$$

Using $F = ma$

$$= 1.5 \times 10 \times 6.0 \times 10^4$$

$$= 1.5 \times 10^4 \text{ N}$$

3. A car of mass 1,200 kg travelling at 45 m/s is brought to rest in 9 seconds. Calculate the average retardation of the car and the average force applied by the brakes.

Solution

Since the car comes to rest, $v = 0$, $a = (v - u) / t = (0 - 45) / 9 = -5 \text{ m/s}$ (retardation)

$$F = ma = (1200 \times -5) \text{ N} = -6,000 \text{ N} \text{ (braking force)}$$

4. A truck of mass 2,000 kg starts from rest on horizontal rails. Find the speed 3 seconds after starting if the tractive force by the engine is 1,000 N.

Solution

$$\text{Impulse} = Ft = 1,000 \times 3 = 3,000 \text{ Ns}$$

Let v be the velocity after 3 seconds. Since the truck was initially at rest then $u = 0$.

Change in momentum $= mv - mu$

$$= (2,000 \times v) - (2,000 \times 0)$$

$$= 2,000 v$$

But impulse = change in momentum

$$2,000 v = 3,000$$

$$v = 3 / 2 = 1.5 \text{ m/s.}$$

Weight of a body in a lift or elevator

When a body is in a lift at rest then the weight

$$W = mg$$

When the lift moves upwards with acceleration 'a' then the weight becomes

$$W = m(a + g)$$

If the lift moves downwards with acceleration 'a' then the weight becomes

$$W = m(g - a)$$

Example

A girl of mass stands inside a lift which is accelerated upwards at a rate of 2 m/s^2 . Determine the reaction of the lift at the girls' feet.

Solution

Let the reaction at the girls' feet be 'R' and the weight 'W'

The resultant force $F = R - W$

$$= (R - 500) \text{ N}$$

Using $F = ma$, then $R - 500 = 50 \times 2$, $R = 100 + 500 = 600 \text{ N}$.

Newton's third law (law of interaction)

This law states that **"For every action or force there is an equal and opposite force or reaction"**

Example

A girl of mass 50 Kg stands on roller skates near a wall. She pushes herself against the wall with a force of 30N. If the ground is horizontal and the friction on the roller skates is negligible, determine her acceleration from the wall.

Solution

Action = reaction = 30 N

Force of acceleration from the wall = 30 N

$$F = ma$$

$$a = F/m = 30/50 = 0.6 \text{ m/s}^2$$

Linear collisions

Linear collision occurs when two bodies collide head-on and move along the same straight line. There are two types of collisions;

- Inelastic collision:** - this occurs when two bodies collide and stick together i.e. hitting putty on a wall. Momentum is conserved.
- Elastic collision:** - occurs when bodies collide and bounce off each other after collision. Both momentum and kinetic energy are conserved.

Collisions bring about a law derived from both Newton's third law and conservation of momentum. This law is known as **the law of conservation of linear momentum** which states that **"when no outside forces act on a system of moving objects, the total momentum of the system stays constant"**.

Examples

1. A bullet of mass 0.005 kg is fired from a gun of mass 0.5 kg. If the muzzle velocity of the bullet is 300 m/s, determine the recoil velocity of the gun.

Solution

Initial momentum of the bullet and the gun is zero since they are at rest.

Momentum of the bullet after firing = $(0.005 \times 350) = 1.75 \text{ kgm/s}$

But momentum before firing = momentum after firing hence

$$0 = 1.75 + 0.5 v \text{ where 'v' = recoil velocity}$$

$$0.5 v = -1.75$$

$$v = -1.75/0.5 = -3.5 \text{ m/s (recoil velocity)}$$

2. A resultant force of 12 N acts on a body of mass 2 kg for 10 seconds. What is the change in momentum of the body?

Solution

$$\begin{aligned} \text{Change in momentum} &= \Delta P = mv - mu = Ft \\ &= 12 \times 10 = 12 \text{ Ns} \end{aligned}$$

3. A minibus of mass 1,500 kg travelling at a constant velocity of 72 km/h collides head-on with a stationary car of mass 900 kg. The impact takes 2 seconds before the two move together at a constant velocity for 20 seconds. Calculate

- The common velocity
- The distance moved after the impact
- The impulsive force
- The change in kinetic energy

Solution

- a) Let the common velocity be 'v'

Momentum before collision = momentum after collision

$$(1500 \times 20) + (900 \times 0) = (1500 + 900) v$$

$$30,000 = 2,400v$$

$$v = 30,000/2,400 = 12.5 \text{ m/s (common velocity)}$$

- b) After impact, the two bodies move together as one with a velocity of 12.5 m/s

Distance = velocity \times time

$$= 12.5 \times 20$$

$$= 250 \text{ m}$$

- c) Impulse = change in momentum
 $= 1500 (20 - 12.5)$ for minibus or
 $= 900 (12.5 - 0)$ for the car
 $= 11,250 \text{ Ns}$

$$\text{Impulse force } F = \text{impulse/time} = 11,250/2 = 5,625 \text{ N}$$

- d) K.E before collision = $\frac{1}{2} \times 1,500 \times 20^2 = 3 \times 10^5 \text{ J}$

$$\text{K.E after collision} = \frac{1}{2} \times 2400 \times 12.5^2 = 1.875 \times 10^5 \text{ J}$$

$$\text{Therefore, change in K.E} = (3.00 - 1.875) \times 10^5 = 1.25 \times 10^5 \text{ J}$$

Some of the applications of the law of conservation of momentum

- Rocket and jet propulsion:** - rocket propels itself forward by forcing out its exhaust gases. The hot gases are pushed through exhaust nozzle at high velocity therefore gaining momentum to move forward.
- The garden sprinkler:** - as water passes through the nozzle at high pressure it forces the sprinkler to rotate.

Solid friction

Friction is a force which opposes or tends to oppose the relative motion of two surfaces in contact with each other.

Measuring frictional forces

We can relate weight of bodies in contact and the force between them. This relationship is called coefficient of friction. **Coefficient of friction is defined as the ratio of the force needed to overcome friction F_f to the perpendicular force between the surfaces F_n .** Hence

$$\mu = F_f / F_n$$

Examples

1. A box of mass 50 kg is dragged on a horizontal floor by means of a rope tied to its front. If the coefficient of kinetic friction between the floor and the box is 0.30, what is the force required to move the box at uniform speed?

Solution

$$F_f = \mu F_n$$

$$F_n = \text{weight} = 50 \times 10 = 500 \text{ N}$$

$$F_f = 0.30 \times 500 = 150 \text{ N}$$

2. A block of metal with a mass of 20 kg requires a horizontal force of 50 N to pull it with uniform velocity along a horizontal surface. Calculate the coefficient of friction between the surface and the block. (take $g = 10 \text{ m/s}^2$)

Solution

Since motion is uniform, the applied force is equal to the frictional force

$$F_n = \text{normal reaction} = \text{weight} = 20 \times 10 = 200 \text{ N}$$

$$\text{Therefore, } \mu = F_f / F_n = 50 / 200 = 0.25.$$

Laws of friction

It is difficult to perform experiments involving friction and thus the following statements should therefore be taken merely as approximate descriptions: -

1. Friction is always parallel to the contact surface and in the opposite direction to the force tending to produce or producing motion.
2. Friction depends on the nature of the surfaces and materials in contact with each other.
3. Sliding (kinetic) friction is less than static friction (friction before the body starts to slide).
4. Kinetic friction is independent of speed.
5. Friction is independent of the area of contact.
6. Friction is proportional to the force pressing the two surfaces together.

Applications of friction

1. Match stick
2. Chewing food

3. Brakes
4. Motion of motor vehicles
5. Walking

Methods of reducing friction

1. Rollers
2. Ball bearings in vehicles and machines
3. Lubrication / oiling
4. Air cushioning in hovercrafts

Example

A wooden box of mass 30 kg rests on a rough floor. The coefficient of friction between the floor and the box is 0.6. Calculate

- a) The force required to just move the box
- b) If a force of 200 N is applied the box with what acceleration will it move?

Solution

- a) Frictional force $F_f = \mu F_n = \mu(mg)$
 $= 0.6 \times 30 \times 10 = 180 \text{ N}$
- b) The resultant force = $200 - 180 = 20 \text{ N}$
 From $F = ma$, then $20 = 30 a$
 $a = 20 / 30 = 0.67 \text{ m/s}^2$

Viscosity

This is the internal friction of a fluid. Viscosity of a liquid decreases as temperature increases. When a body is released in a viscous fluid it accelerates at first then soon attains a steady velocity called terminal velocity. Terminal velocity is attained when $F + U = mg$ where F is viscous force, U is upthrust and mg is weight.

CHAPTER FOUR

ENERGY, WORK, POWER AND MACHINES

Energy

This is the ability to do work.

Forms of energy.

1. Chemical energy: - this is found in foods, oils charcoal firewood etc.
2. Mechanical energy: - there are two types;
 - i. Potential energy – a body possesses potential energy due to its relative position or state
 - ii. Kinetic energy – energy possessed by a body due to its motion i.e. wind, water

- iii. **Wave energy** – wave energy may be produced by vibrating objects or particles i.e. light, sound or tidal waves.
- iv. **Electrical energy** – this is energy formed by conversion of other forms of energy i.e. generators.

Transformation and conservation of energy

Any device that facilitates energy transformations is called **transducer**. Energy can be transformed from one form to another i.e. mechanical – electrical – heat energy. **The law of conservation of energy** states that **“energy cannot be created or destroyed; it can only be transformed from one form to another”**.

Work

Work is done when a force acts on a body and the body moves in the direction of the force.

Work done = force × distance moved by object

$$W = F \times d$$

Work is measured in **Nm. 1 Nm = 1 Joule (J)**

Examples

1. Calculate the work done by a stone mason lifting a stone of mass 15 kg through a height of 2.0 m. (take $g=10\text{N/kg}$)

Solution

$$\begin{aligned} \text{Work done} &= \text{force} \times \text{distance} \\ &= (15 \times 10) \times 2 = 300 \text{ Nm or } 300 \text{ J} \end{aligned}$$

2. A girl of mass 50 kg walks up a flight of 12 steps. If each step is 30 cm high, calculate the work done by the girl climbing the stairs.

Solution

$$\begin{aligned} \text{Work done} &= \text{force} \times \text{distance} \\ &= (50 \times 10) \times (12 \times 30) \div 100 = 500 \times 3.6 = 1,800 \text{ J} \end{aligned}$$

3. A force of 7.5 N stretches a certain spring by 5 cm. How much work is done in stretching this spring by 8.0 cm?

Solution

A force of 7.5 produces an extension of 5.0 cm.

$$\text{Hence } 8.0 \text{ cm} = (7.5 \times 8) / 5 = 12.0 \text{ N}$$

$$\begin{aligned} \text{Work done} &= \frac{1}{2} \times \text{force} \times \text{extension} \\ &= \frac{1}{2} \times 12.0 \times 0.08 = 0.48 \text{ J} \end{aligned}$$

4. A car travelling at a speed of 72 km/h is uniformly retarded by an application of brakes and comes to rest after 8 seconds. If the car with its occupants has a mass of 1,250 kg.

Calculate;

- a) The breaking force
- b) The work done in bringing it to rest

Solution

- a) $F = ma$ and $a = \frac{v - u}{t}$
 But $72 \text{ km/h} = 20 \text{ m/s}$
 $a = \frac{0 - 20}{8} = -2.5 \text{ m/s}$
 Retardation = 2.5 m/s
 Braking force $F = 1,250 \times 2.5$
 $= 3,125 \text{ N}$
- b) Work done = kinetic energy lost by the car
 $= \frac{1}{2} mv^2 - \frac{1}{2} mu^2$
 $= \frac{1}{2} \times 1250 \times 0^2 - \frac{1}{2} \times 1250 \times 20^2$
 $= -2.5 \times 10^5 \text{ J}$

5. A spring constant $k = 100 \text{ Nm}$ is stretched to a distance of 20 cm . calculate the work done by the spring.

Solution

$$\begin{aligned} \text{Work} &= \frac{1}{2} ks^2 \\ &= \frac{1}{2} \times 100 \times 0.2^2 \\ &= 2 \text{ J} \end{aligned}$$

Power

Power is the time rate of doing work or the rate of energy conversion.

Power (P) = work done / time

$$P = \frac{W}{t}$$

The SI unit for power is the **watt (W)** or **joules per second (J/s)**.

Examples

1. A person weighing 500 N takes 4 seconds to climb upstairs to a height of 3.0 m . what is the average power in climbing up the height?

Solution

$$\begin{aligned} \text{Power} &= \frac{\text{work done}}{\text{time}} = \frac{\text{force} \times \text{distance}}{\text{time}} \\ &= \frac{500 \times 3}{4} = 375 \text{ W} \end{aligned}$$

2. A box of mass 500 kg is dragged along a level ground at a speed of 12 m/s . If the force of friction between the box and floor is 1200 N . Calculate the power developed.

Solution

$$\begin{aligned} \text{Power} &= F v \\ &= 2,000 \times 12 \\ &= 24,000 \text{ W} = 24 \text{ kW}. \end{aligned}$$

Machines

A machine is any device that uses a force applied at one point to overcome a force at another point. Force applied is called the **effort** while the resisting force overcome is called **load**.

Machines makes work easier or convenient to be done. Three quantities dealing with machines are:-

- a) **Mechanical advantage (M.A.)** - this is defined as the ratio of the load (L) to the effort (E). It has no units.

$$M.A = \text{load } (L) / \text{effort } (E)$$

b) **Velocity ratio** – this is the ratio of the distance moved by the effort to the distance moved by the load

$$V.R = \text{distance moved by effort} / \text{distance moved by the load}$$

c) **Efficiency** – is obtained by dividing the work output by the work input and the getting percentage

$$\text{Efficiency} = (\text{work output} / \text{work input}) \times 100$$

$$= (M.A / V.R) \times 100$$

$$= (\text{work done on load} / \text{work done on effort}) \times 100$$

Examples

1. A machine; the load moves 2 m when the effort moves 8 m. If an effort of 20 N is used to raise a load of 60 N, what is the efficiency of the machine?

Solution

$$\text{Efficiency} = (M.A / V.R) \times 100 \quad M.A = \text{load} / \text{effort} = 60 / 20 = 3$$

$$V.R = D_E / D_L = 8 / 2 = 4$$

$$\text{Efficiency} = \frac{3}{4} \times 100 = 75\%$$

Some simple machines

a) **Lever** – this is a simple machine whose operation relies on the principle of moments

b) **Pulleys** – this is a wheel with a grooved rim used for lifting heavy loads to high levels.

The can be used as a single fixed pulley, or as a block-and-tackle system.

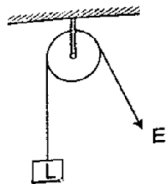

(a) Single fixed pulley

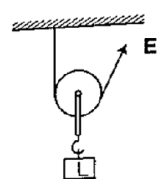

(b) Single moveable pulley

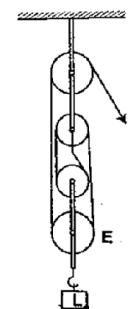

(c) Block-and-tackle system

$$M.A = \text{Load} / \text{Effort}$$

$$V.R = \text{no. of pulleys} / \text{no. of strings supporting the load}$$

Example

A block and tackle system has 3 pulleys in the upper fixed block and two in the lower moveable block. What load can be lifted by an effort of 200 N if the efficiency of the machine is 60%?

Solution

$$V.R = \text{total number of pulleys} = 5$$

$$\text{Efficiency} = (M.A / V.R) \times 100 = 60\%$$

$$0.6 = M.A / 5 \Rightarrow 3, \text{ but } M.A = \text{Load} / \text{Effort}$$

$$\text{Therefore, load} = 3 \times 200 = 600 \text{ N}$$

- c) **Wheel and axle** – consists of a large wheel of big radius attached to an axle of smaller radius.

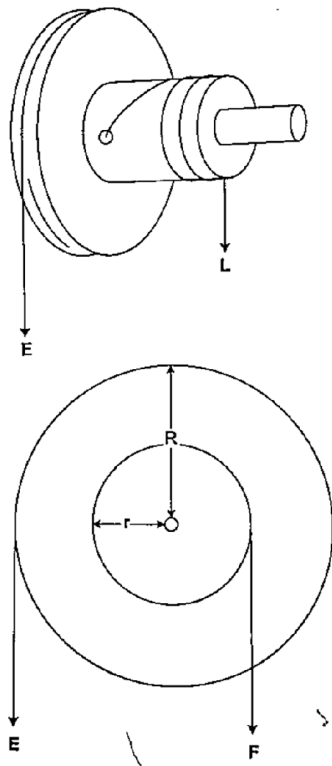

$$V.R = R / r \text{ and } M.A = R / r$$

Example

A wheel and axle is used to raise a load of 280 N by a force of 40 N applied to the rim of the wheel. If the radii of the wheel and axle are 70 cm and 5 cm respectively. Calculate the M.A, V.R and efficiency.

Solution

$$M.A = 280 / 40 = 7$$

$$V.R = R / r = 70 / 5 = 14$$

$$\text{Efficiency} = (M.A / V.R) \times 100 = 7 / 14 \times 100 = 50 \%$$

d) **Inclined plane:** -

$$V.R = 1 / \sin \theta \quad M.A = \text{Load} / \text{Effort}$$

Example

A man uses an inclined plane to lift a 50 kg load through a vertical height of 4.0 m. the inclined plane makes an angle of 30° with the horizontal. If the efficiency of the inclined plane is 72%, calculate;

- a) The effort needed to move the load up the inclined plane at a constant velocity.
- b) The work done against friction in raising the load through the height of 4.0 m. (take $g = 10 \text{ N/kg}$)

Solution

a) $V.R = 1 / \sin C = 1 / \sin 30^\circ = 2$ $M.A = \text{efficiency} \times V.R = (72/100) \times 2 = 1.44$
 $\text{Effort} = \text{load (mg)} / \text{effort} (50 \times 10) / 1.44 = 347.2 \text{ N}$

b) Work done against friction = work input – work output

Work output = $m g h = 50 \times 10 \times 4 = 2,000 \text{ J}$

Work input = effort \times distance moved by effort

$$347.2 \times (4 \times \sin 30^\circ) = 2,777.6 \text{ J}$$

Therefore work done against friction = $2,777.6 - 2,000 = 777.6 \text{ J}$

e) **The screw:** - the distance between two successive threads is called the pitch

$$V.R \text{ of screw} = \text{circumference of screw head} / \text{pitch } P$$

$$= 2\pi r / P$$

Example

A car weighing 1,600 kg is lifted with a jack-screw of 11 mm pitch. If the handle is 28 cm from the screw, find the force applied.

Solution

Neglecting friction $M.A = V.R$

$$V.R = 2\pi r / P = M.A = L / E$$

$$1,600 / E = (2\pi \times 0.28) / 0.011$$

$$E = (1,600 \times 0.011 \times 7) / 22 \times 2 \times 0.28 = 10 \text{ N}$$

f) **Gears:** - the wheel in which effort is applied is called the driver while the load wheel is the driven wheel.

$$V.R = \text{revolutions of driver wheel} / \text{revolutions of driven wheel}$$

Or

$$V.R = \text{no. of teeth in the driven wheel} / \text{no. of teeth in the driving wheel}$$

Example

- g) **Pulley belts:** -these are used in bicycles and other industrial machines

$V.R = \text{radius of the driven pulley} / \text{radius of the driving pulley}$

- h) **Hydraulic machines**

$V.R = R^2 / r^2$ where R - radius of the load piston and r - radius of the effort piston

Example

The radius of the effort piston of a hydraulic lift is 1.4 cm while that of the load piston is 7.0 cm. This machine is used to raise a load of 120 kg at a constant velocity through a height of 2.5 cm. given that the machine is 80% efficient, calculate;

- a) The effort needed
b) The energy wasted using the machine

Solution

a) $V.R = R^2 / r^2 = (7 \times 7) / 1.4 \times 1.4 = 25$

Efficiency = $M.A / V.R = (80 / 100) \times 25 = 20$

But $M.A = \text{Load} / \text{Effort} = (120 \times 10) / 20 = 60 \text{ N}$

b) Efficiency = $\text{work output} / \text{work input} = \text{work done on load} (m g h) / 80$
 $= (120 \times 10 \times 2.5) / \text{work input}$

$80 / 100 = 3,000 / \text{work input}$

Work input = $(3,000 \times 100) / 80 = 3,750 \text{ J}$

Energy wasted = $\text{work input} - \text{work output}$
 $= 3,750 - 3,000 = 750 \text{ J}$

CHAPTER FIVE

CURRENT ELECTRICITY

Electric potential difference and electric current

Electric current

Electric potential difference (p. d) is defined as the work done per unit charge in moving charge from one point to another. It is measured in **volts**.

Electric current is the rate of flow of charge. P. d is measured using a voltmeter while current is measured using an ammeter. The SI units for charge is **amperes (A)**.

Ammeters and voltmeters

In a circuit an ammeter is always connected in series with the battery while a voltmeter is always connected parallel to the device whose voltage is being measured.

Ohm's law

This law gives the relationship between the voltage across a conductor and the current flowing through it. Ohm's law states that **"the current flowing through a metal conductor is directly proportional to the potential difference across the ends of the wire provided that temperature and other physical conditions remain constant"**

Mathematically $V \propto I$

So $V/I = \text{constant}$, this constant of proportionality is called **resistance**

$$V/I = \text{Resistance (R)}$$

Resistance is measured in **ohms** and given the symbol Ω

Examples

1. A current of 2mA flows through a conductor of resistance 2 k Ω . Calculate the voltage across the conductor.

Solution

$$V = IR = (2 \times 10^{-3}) \times (2 \times 10^3) = 4 \text{ V.}$$

2. A wire of resistance 20 Ω is connected across a battery of 5 V. What current is flowing in the circuit?

Solution

$$I = V/R = 5 / 20 = 0.25 \text{ A}$$

Ohmic and non-ohmic conductors

Ohmic conductors are those that obey Ohms law ($V \propto I$) and a good example is nichrome wire i.e. the nichrome wire is not affected by temperature.

Non-ohmic conductors do not obey Ohms law i.e. bulb filament (tungsten), thermistor couple, semi-conductor diode etc. They are affected by temperature hence non-linear.

Factors affecting the resistance of a metallic conductor

1. **Temperature** – resistance increases with increase in temperature
2. **Length of the conductor** – increase in length increases resistance
3. **Cross-sectional area** – resistance is inversely proportional to the cross-sectional area of a conductor of the same material.

Resistivity of a material is numerically equal to the resistance of a material of unit length and unit cross-sectional area. It is symbolized by ρ and the units are ohmmeter (**Ωm**). It is given by the following formula;

$$\rho = AR/l \text{ where } A - \text{cross-sectional area, } R - \text{resistance, } l - \text{length}$$

Example

Given that the resistivity of nichrome is $1.1 \times 10^{-6} \Omega\text{m}$, what length of nichrome wire of diameter 0.42 mm is needed to make a resistance of 20 Ω ?

Solution

$$\rho = AR/l, \text{ hence } l = RA/\rho = 20 \times 3.142 \times (2.1 \times 10^{-4}) / 1.1 \times 10^{-6} = 2.52 \text{ m}$$

Resistors

Resistors are used to regulate or control the magnitude of current and voltage in a circuit according to Ohms law.

Types of resistors

- i) **Fixed resistors** – they are wire-wound or carbon resistors and are designed to give a fixed resistance.



Variable Carbon resistor consist of the rheostat and potentiometer. The resistance can be varied by sliding a metal

contact to generate desirable resistance.

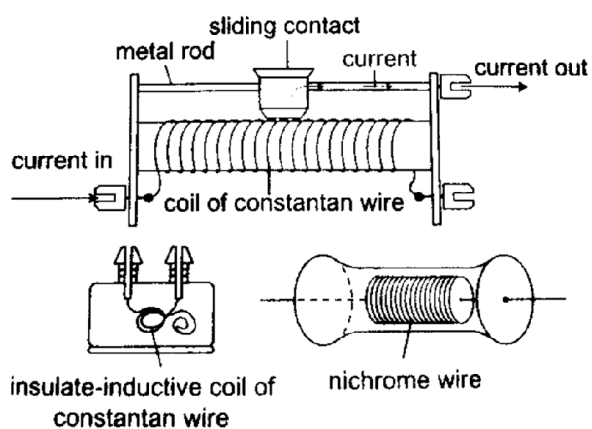

Wire-wound resistor

Resistor combination

- a) **Series combination**

Consider the following loop

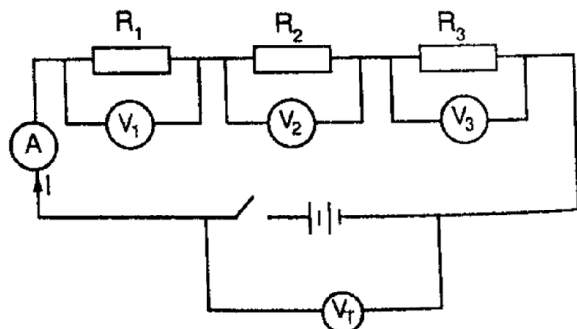

Since it is in series then,

$$V_T = V_1 + V_2 + V_3$$

The same current (I) flows through the circuit (resistors), hence

$$IR_T = I(R_1 + R_2 + R_3), \text{ dividing through by } I, \text{ then}$$

$$R_T = R_1 + R_2 + R_3$$

Therefore for resistors connected in series the equivalent resistance (R_{eq}) is equal to the total sum of their individual resistances.

$$R_{eq} = R_1 + R_2 + R_3$$

b) Parallel combination

Consider the following circuit

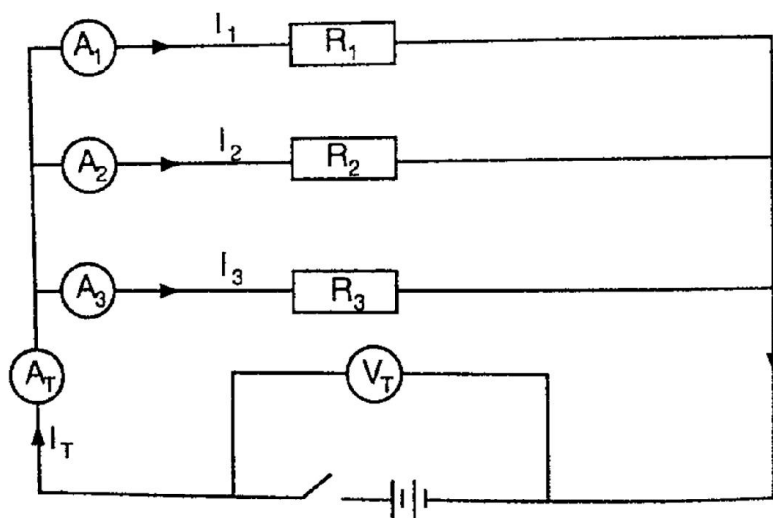

Total current is given by;

$$I_T = I_1 + I_2 + I_3. \text{ But } I_T = V_T/R_T = V_1/R_1 + V_2/R_2 + V_3/R_3$$

Since in parallel, $V_T = V_1 = V_2 = V_3$

Then $1/R_T = 1/R_1 + 1/R_2 + 1/R_3$, for 'n' resistors in parallel

$$1/R_T = 1/R_1 + 1/R_2 + 1/R_3 \dots \dots \dots 1/R_n$$

If only two resistors are involved then the equivalent resistance becomes

$$1/R_{eq} = 1/R_1 + 1/R_2 = (R_1 + R_2)/R_1 R_2$$

Examples

1. Calculate the effective resistance in the following

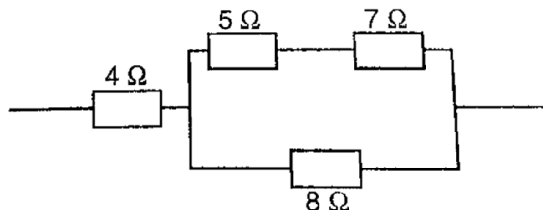

Solution

This reduces to

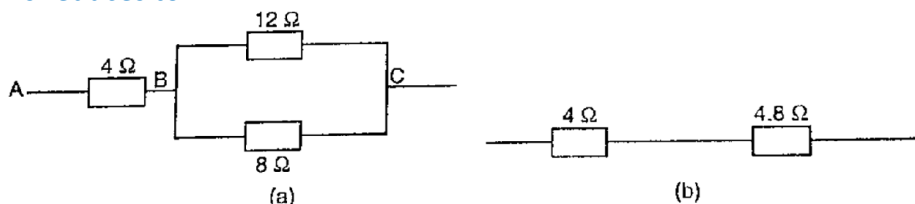

Combining the two in parallel;

$$1/R_{eq} = (R_1 + R_2)/R_1 R_2 = 20/96$$

$$1/R_{eq} = 20/96, \text{ therefore } R_{eq} = 96/20 = 4.8 \Omega$$

Lastly combining the two in series;

$$\text{Then } R_{eq} = 4 \Omega + 4.8 \Omega = 8.8 \Omega$$

2. In the diagram below, a current of 0.8 A, passing through an arrangement of resistors as shown below. Find the current through the 10 Ω resistor.

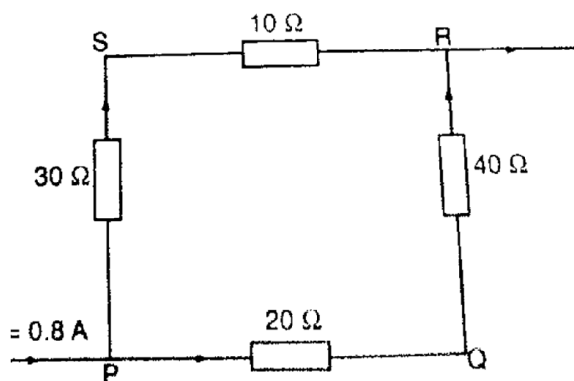

Solution

Combining those in series then this can be replaced by two resistors of 60 Ω and 40 Ω.

$$\text{Current through } 10 \Omega = (\text{p.d. between P and R}) / (30 + 10) \Omega$$

$$\text{p.d between P and R} = 0.8 \times R_{eq}. R_{eq} = (40 \times 60) / 40 + 60 = 2400 / 100 = 24 \Omega$$

$$\text{p.d across R and P} = 0.8 \times 24 \text{ (V=IR)}$$

therefore, current through $10\ \Omega = 19.2 / 10 + 30 = 0.48\ \text{A}$

Electromotive force and internal resistance

Electromotive force (e.m.f.) is the p.d across a cell when no current is being drawn from the cell. The p.d across the cell when the circuit is closed is referred to as the terminal voltage of the cell. Internal resistance of a cell is therefore the resistance of flow of current that they generate. Consider the following diagram;

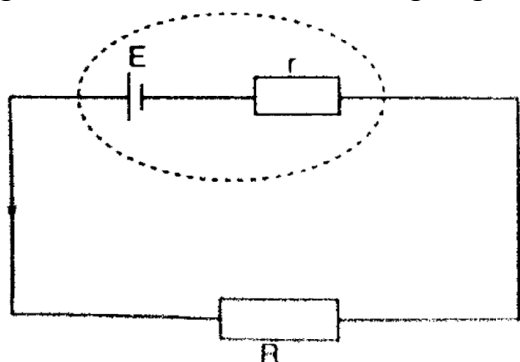

The current flowing through the circuit is given by the equation,

$$\text{Current} = \text{e.m.f} / \text{total resistance}$$

$$I = E / R + r \text{ where } E - \text{e.m.f of the cell}$$

$$\text{Therefore } E = I (R + r) = IR + I r = V + I r$$

Examples

1. A cell drives a current of $0.6\ \text{A}$ through a resistance of $2\ \Omega$. if the value of resistance is increased to $7\ \Omega$ the current becomes $0.2\ \text{A}$. calculate the value of e.m.f of the cell and its internal resistance.

Solution

Let the internal resistance be 'r' and e.m.f be 'E'.

$$\text{Using } E = V + I r = IR + I r$$

Substitute for the two sets of values for I and R

$$E = 0.6 \times (2 + 0.6 r) = 1.2 + 0.36 r$$

$$E = 0.6 \times (7 + 0.2 r) = 4.2 + 0.12 r$$

Solving the two simultaneously, we have,

$$E = 1.5\ \text{v and } R = 0.5\ \Omega$$

2. A battery consists of two identical cells, each of e.m.f $1.5\ \text{v}$ and internal resistance of $0.6\ \Omega$, connected in parallel. Calculate the current the battery drives through a $0.7\ \Omega$ resistor.

Solution

When two identical cells are connected in series, the equivalent e.m.f is equal to that of only one cell. The equivalent internal resistance is equal to that of two such resistance connected in parallel. Hence $R_{\text{eq}} = R_1 R_2 / R_1 + R_2 = (0.6 \times 0.6) / 0.6 + 0.6 = 0.36 / 1.2 = 0.3\ \Omega$

$$\text{Equivalent e.m.f} = 1.5 / (0.7 + 0.3) = 1.5\ \text{A}$$

Hence current flowing through $0.7\ \Omega$ resistor is $1.5\ \text{A}$

CHAPTER SIX WAVES II

Properties of waves

Waves exhibit various properties which can be conveniently demonstrated using the ripple tank. It consists of a transparent tray filled with water and a white screen as the bottom. On top we have a source of light. A small electric motor (vibrator) is connected to cause the disturbance which produces waves.

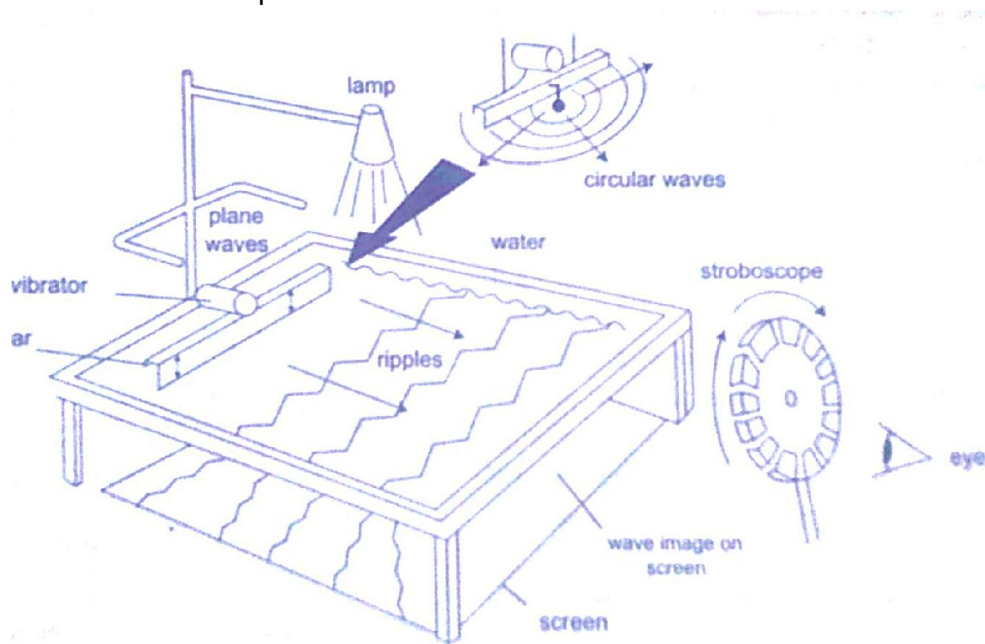

The wave fronts represent wave patterns as they move along.

Rectilinear propagation

This is the property of the waves travelling in straight lines and perpendicular to the wave front. The following diagrams represent rectilinear propagation of water waves.

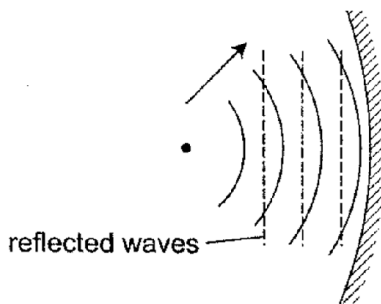
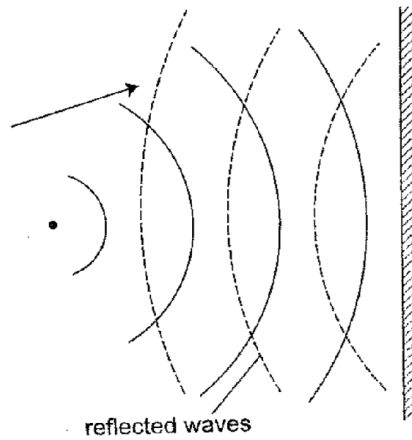
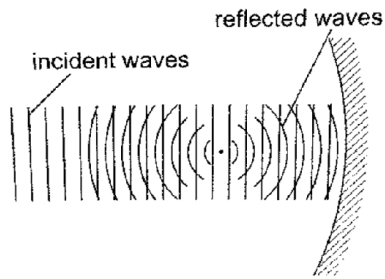
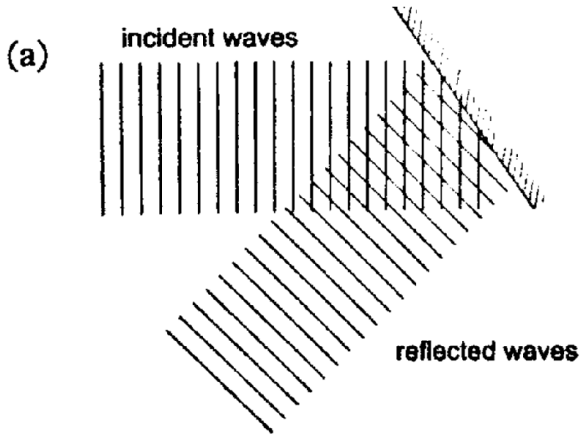

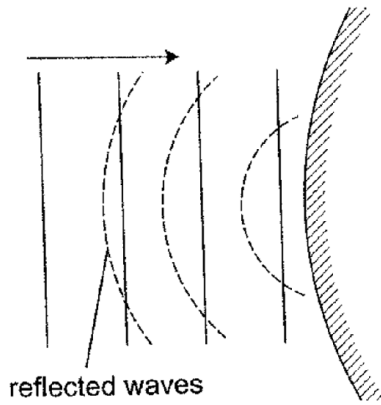

Refraction

This is the change of direction of waves at a boundary when they move from one medium to another. This occurs when an obstacle is placed in the path of the waves. The change of direction occurs at the boundary between deep and shallow waters and only when the waves hit the boundary at an angle.

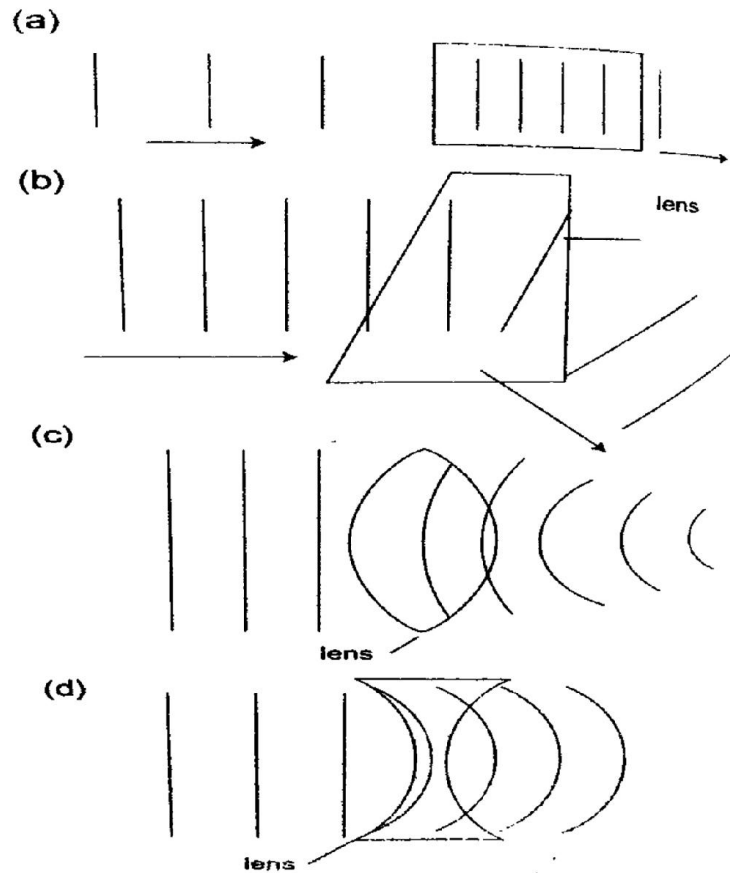

Diffraction of waves

This occurs when waves pass an edge of an obstacle or a narrow gap, they tend to bend around the corner and spread out beyond the obstacle or gap.

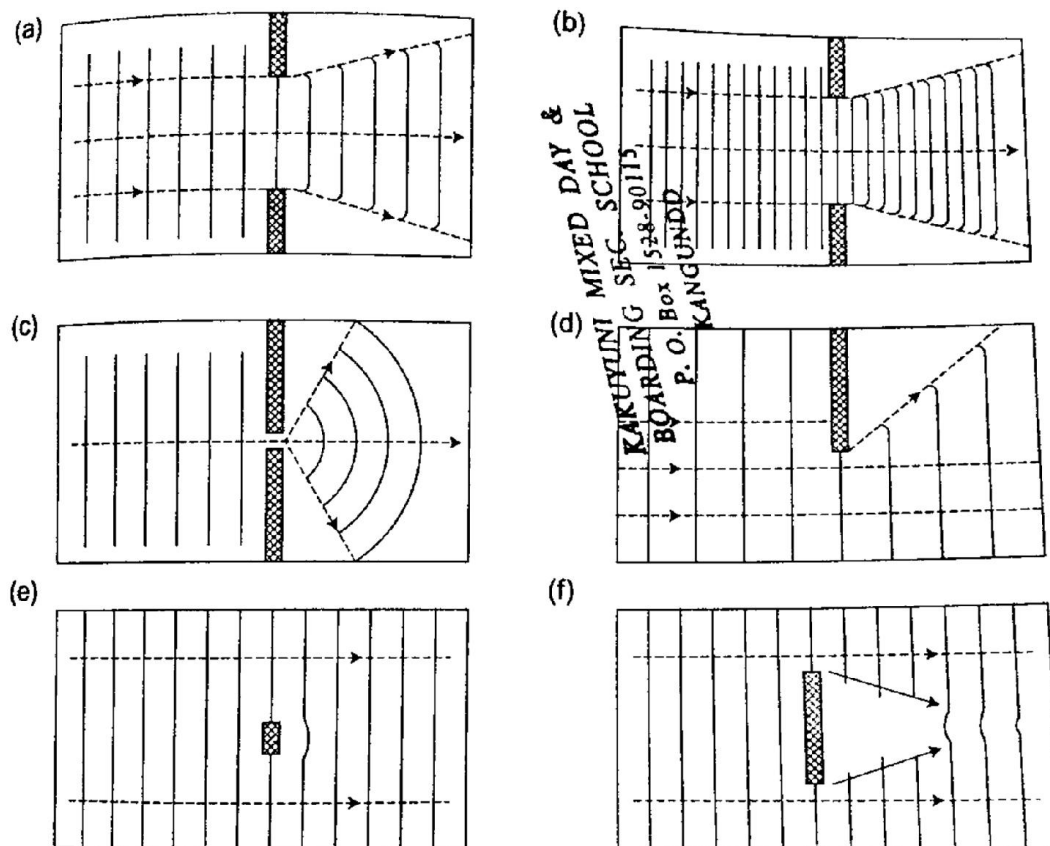

Interference of waves

This occurs when two waves merge and the result can be a much larger wave, smaller wave or no wave at all. When the waves are in phase they add up and reinforce each other. This is called a constructive interference and when out of phase they cancel each other out and this is known as destructive interference.

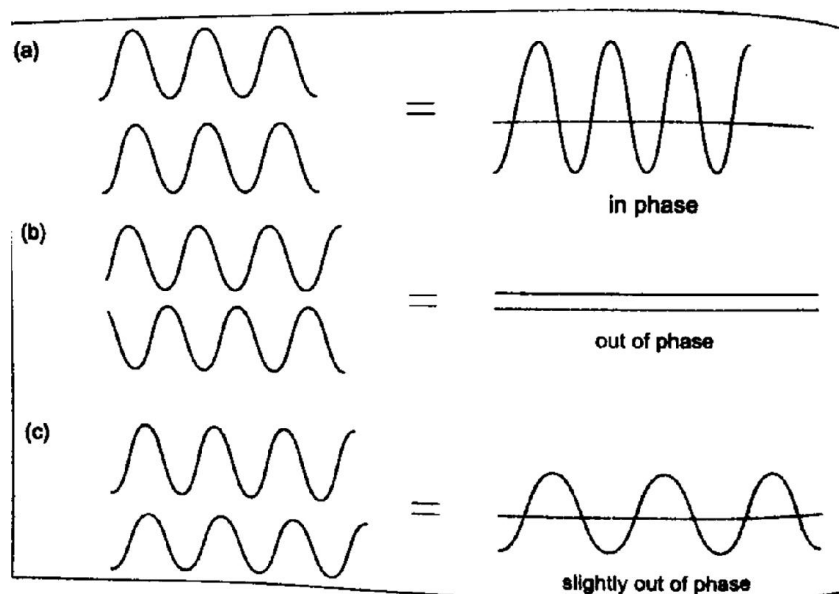

A ripple tank can be used to produce both constructive and destructive waves as shown below in the following diagram.

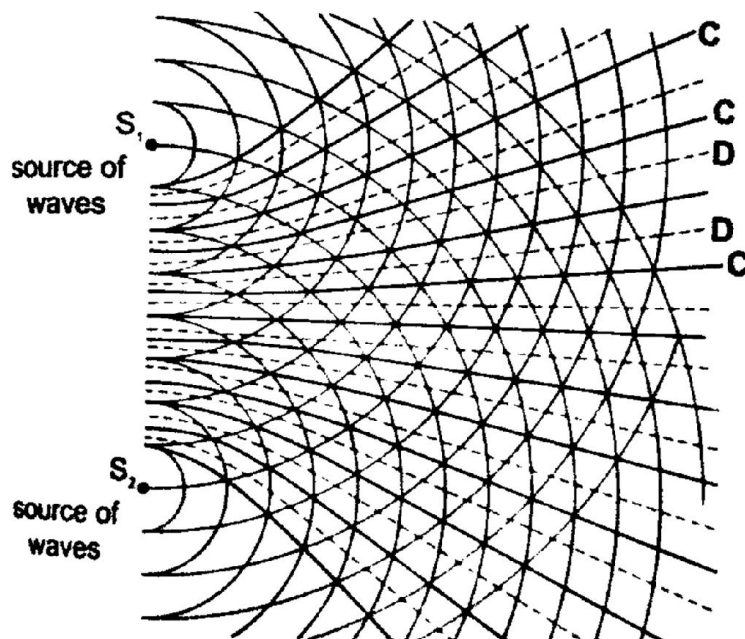

Interference in sound

Two loud speakers L_1 and L_2 are connected to the same signal generator so that sound waves from each of them are in phase. The two speakers are separated by a distance of the order of wavelengths i.e. 0.5 m apart for sound frequency of 1,000 Hz.

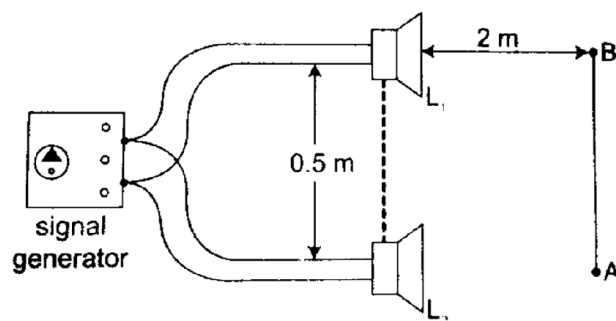

If you walk along line AB about 2m away from the speakers, the intensity of sound rises and falls alternately hence both destructive and constructive interference will be experienced.

Stationary waves

They are also known as standing waves and are formed when two equal progressive waves travelling in opposite direction are superposed on each other. When the two speakers are placed facing each other they produce standing waves. A rope tied at one end will still produce stationary waves.

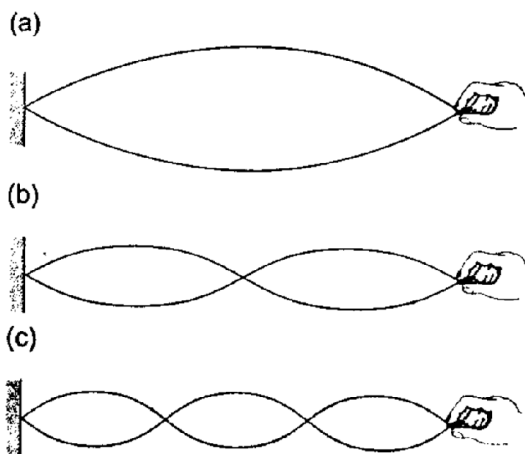

CHAPTER SEVEN ELECTROSTATICS II

Electric fields

An electric field is the space around a charged body where another charged body would be acted on by a force. These fields are represented by lines of force. This line of force also called an electric flux line points in the direction of the force.

Electric field patterns

Just like in magnetic fields, the closeness of the electric field-lines of force is the measure of the field strength. Their direction is always from the north or positive to the south or negative.

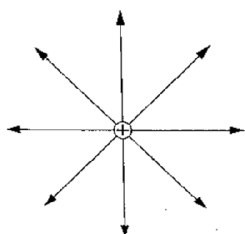

Electric field pattern for an isolated positive charge

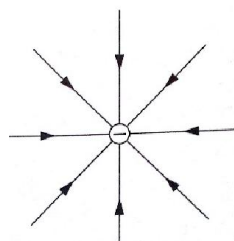

Electric field pattern for an isolated negative charge

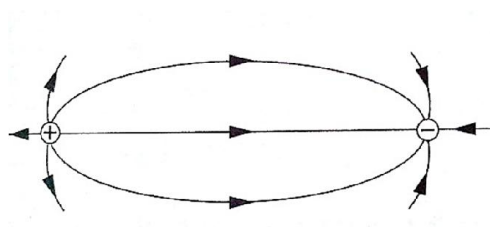

Electric field pattern for a dipole

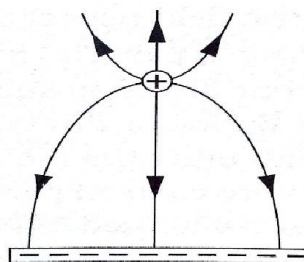

Electric field pattern for a positive charge and a line of charge

Charge distribution on conductors' surface

A proof plane is used to determine charge distribution on spherical or pear-shaped conductors. For an isolated sphere it is found that the effect is the same for all points on the surface meaning that the charge is evenly distributed on all points on the spherical surface. For a pear-shaped conductor the charge is found to be denser in the regions of large curvature (small radius). The density of charge is greatest where curvature is greatest.

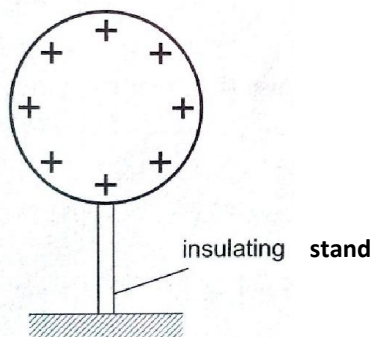

Charge distribution for an isolated spherical conductor

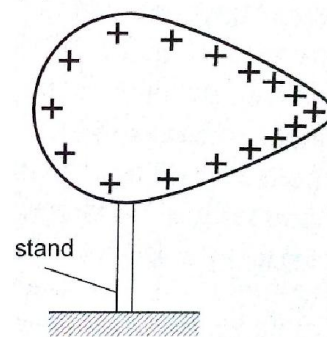

Charge distribution for an isolated pear-shaped conductor

Charges on or action at sharp points

A moving mass of air forms a body with sharp points. The loss of electrons by molecules (ionization) makes the molecules positively charged ions. These ions tend to move in different directions and collide producing more charged particles and this makes the air highly ionized. When two positively charged bodies are placed close to each other, the air around them may cause a spark discharge which is a rush of electrons across the ionized gap, producing heat, light and sound in the process which lasts for a short time. Ionization at sharp projections of isolated charged bodies may sometimes be sufficient to cause a discharge. This discharge produces a glow called **corona discharge** observed at night on masts of ships moving on oceans. The same glow is observed on the trailing edges of aircrafts. This glow in aircrafts and ships is called **St. Elmo's fire**. Aircrafts are fitted with 'pig tails' on the wings to discharge easily.

The lightning arrestors

Lightning is a huge discharge where a large amount of charge rushes to meet the opposite charge. It can occur between clouds or the cloud and the earth. Lightning may not be prevented but protection from its destruction may be done through arrestors. An arrestor consists of a thick copper strip fixed to the outside wall of a building with sharp spikes.

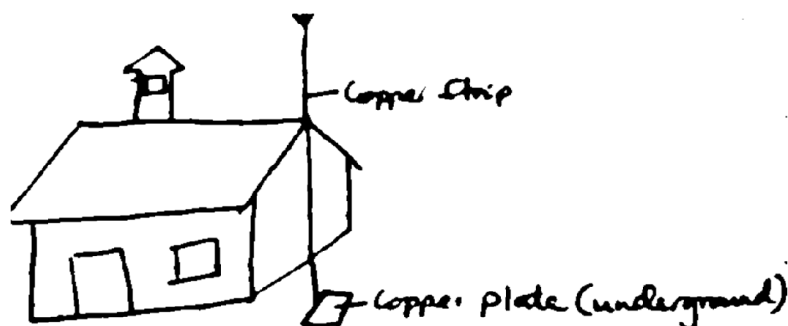

Capacitors and capacitance

A capacitor is a device used for storing charge. It consists of two or more plates separated by either a vacuum or air. The insulating material is called '**dielectric**'. They are symbolized as shown below,



Capacitance $C = Q / V$ where Q- charge and V – voltage.

The units for capacitance are coulombs per volt (Coul /volt) and are called farads.

1 Coul/ volt = 1 farad (F)

1 $\mu\text{F} = 10^{-6}$ F and 1pF = 10^{-12}

Types of capacitors are;

- Paper capacitors
- Electrolyte capacitors
- Variable capacitors
- Plastic capacitors
- Ceramic capacitors
- Mica capacitors

Factors affecting the capacitance of a parallel-plate capacitor

- Distance between the plates:** - reducing separation increases capacitance but the plates should not be very close to avoid ionization which may lead to discharge.
- Area of plate:** - reduction of the effective area leads to reduction in capacitance.
- Dielectric material between plates:** - different materials will produce different capacitance effects.

Charging and discharging a capacitor

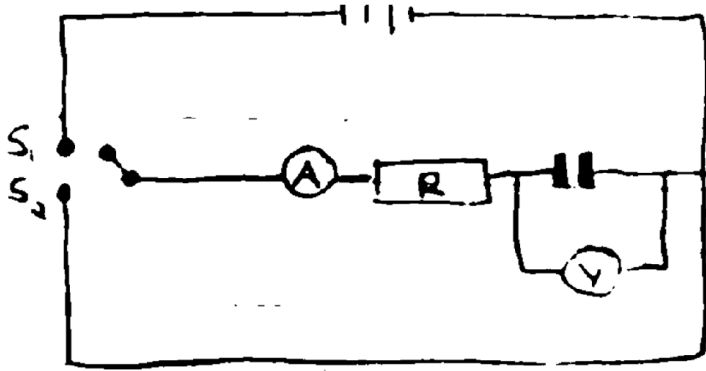

When the switch S_1 is closed the capacitor charges through resistor R and discharges through the same resistor when switch S_2 is closed.

Applications of capacitors

1. **Variable capacitor:** - used in tuning radios to enable it transmit in different frequencies.
2. **Paper capacitors:** - used in mains supply and high voltage installations.
3. **Electrolytic capacitors:** - used in transistor circuits where large capacitance values are required.

Other capacitors are used in reducing sparking as a car is ignited, smoothing rectified current and increasing efficiency in a. c. power transmission.

Example

A capacitor of two parallel plates separated by air has a capacitance of 15pF. A potential difference of 24 volts is applied across the plates,

- a) Determine the charge on the capacitors.
- b) When the space is filled with mica, the capacitance increases to 250pF. How much more charge can be put on the capacitor using a 24 V supply?

Solution

a) $C = Q / V$ then $Q = VC$, hence $Q = (1.5 \times 10^{-12}) \times 24 = 3.6 \times 10^{-10}$ Coul.

b) Mica $C = 250\text{pF}$, $Q = (250 \times 10^{-12}) \times 24 = 6 \times 10^{-9}$ Coul.

Additional charge = $(6 \times 10^{-9}) - (3.6 \times 10^{-10}) = 5.64 \times 10^{-9}$ Coul.

Capacitor combination

1. **Parallel combination** – for capacitors in parallel the total capacitance is the sum of all the separate capacitances.

$$C_T = C_1 + C_2 + C_3 + \dots$$

2. **Series combination** – for capacitors in series, the reciprocal of the total capacitance is equal to the sum of the reciprocals of all the separate capacitances.

$$1 / C_T = 1 / C_1 + 1 / C_2 + 1 / C_3$$

For two capacitors in series then total capacitance becomes,

$$C_T = (C_1 C_2) / (C_1 + C_2)$$

Examples

1. Three capacitors of capacitance 1.5 μF , 2 μF and 3 μF are connected to a potential difference of 12 V as shown.

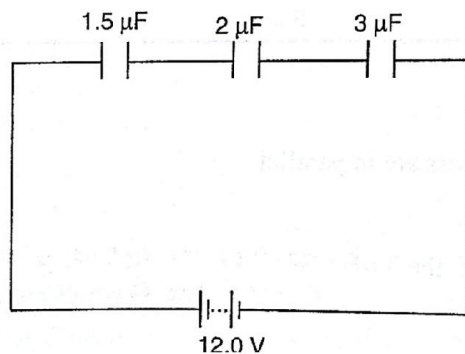

Find;

- The combined capacitance
- The charge on each capacitor
- The voltage across the $2 \mu\text{F}$ capacitor

Solution

- $1/C_T = 1/1.5 + 1/3.0 + 1/2.0 = 3/2$ hence $C_T = 0.67 \mu\text{F}$
 - Total charge, $Q = VC$, $(2/3 \times 10^{-6}) \times 12.0 \text{ V} = 8 \times 10^{-6} = 8 \mu\text{C}$.
 - The charge is the same for each capacitor because they're in series hence $= 8 \mu\text{C}$.
 - $V = Q/C$, then $V = 8 \mu\text{C} / 2 \mu\text{F} = 4 \text{ V}$.
2. Three capacitors of capacitance $3 \mu\text{F}$, $4 \mu\text{F}$ and $5 \mu\text{F}$ are arranged as shown. Find the effective capacitance.

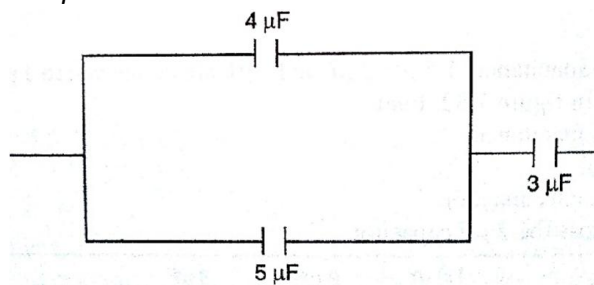

Solution

Since $4 \mu\text{F}$ and $5 \mu\text{F}$ are in parallel then, $C_T = 9 \mu\text{F}$, then the $9 \mu\text{F}$ is in series with $3 \mu\text{F}$,
Hence $C_T = 27/12 = 2.25 \mu\text{F}$

3. Calculate the charges on the capacitors shown below.

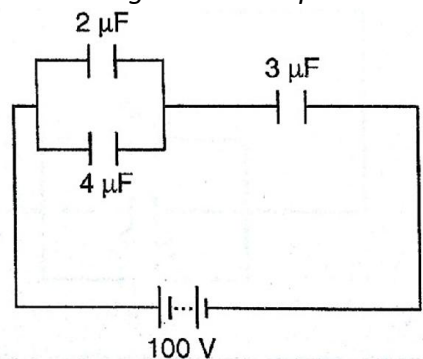

Solution

The $2 \mu\text{F}$ and $4 \mu\text{F}$ are in parallel then combined capacitance $= 6 \mu\text{F}$

The 6 μF is in series with the 3 μF capacitor hence combined capacitance = $18 / 9 = 2 \mu\text{F}$

Total charge $Q = CV$ then $Q = (2.0 \times 10^{-6}) \times 100 = 2.0 \times 10^{-4} \text{ C}$

The charge on the 3 μF capacitor is also equal to $2.0 \times 10^{-4} \text{ C}$

The p.d across the 3 μF capacitor $\Rightarrow V = Q / C \Rightarrow (2.0 \times 10^{-4}) / 3.0 \times 10^{-6}$
 $= 2/3 \times 10^2 = 66.7 \text{ V}$

The p.d across the 2 μF and 4 μF is equal to $100 \text{ V} - 66.7 \text{ V} = 33.3 \text{ V}$,

Hence $Q_1 = CV = 2.0 \times 10^{-6} \times 33.3 = 6.66 \times 10^{-5} \text{ C}$

$Q_2 = CV = 4.0 \times 10^{-6} \times 33.3 = 1.332 \times 10^{-4} \text{ C}$

N.B

Energy stored in a capacitor is calculated as;

Work done (W) = average charge \times potential difference

$$W = \frac{1}{2} QV \text{ or } \frac{1}{2} CV^2$$

Example

A 2 μF capacitor is charged to a potential difference of 120 V. Find the energy stored in it.

Solution

$$W = \frac{1}{2} CV^2 = \frac{1}{2} \times 2 \times 10^{-6} \times 120^2 = 1.44 \times 10^{-2} \text{ J}$$

CHAPTER EIGHT

HEATING EFFECT OF AN ELECTRIC CURRENT

When current flows, electrical energy is transformed into other forms of energy i.e. light, mechanical and chemical changes.

Factors affecting electrical heating

Energy dissipated by current or work done as current flows depends on,

- a) **Current**
- b) **Resistance**
- c) **Time**

This formula summarizes these factors as, $E = I^2 R t$, $E = I V t$ or $E = V^2 t / R$

Examples

1. An iron box has a resistance coil of 30Ω and takes a current of 10 A. Calculate the heat in kJ developed in 1 minute.

Solution

$$E = I^2 R t = 10^2 \times 30 \times 60 = 18 \times 10^4 = 180 \text{ kJ}$$

2. A heating coil providing 3,600 J/min is required when the p.d across it is 24 V. Calculate the length of the wire making the coil given that its cross-sectional area is $1 \times 10^{-7} \text{ m}^2$ and resistivity $1 \times 10^{-6} \Omega \text{ m}$.

Solution

$$E = P t \text{ hence } P = E / t = 3,600 / 60 = 60 \text{ W}$$

$$P = V^2 / R \text{ therefore } R = (24 \times 24) / 60 = 9.6 \Omega$$

$$R = \rho l / A, l = (RA) / \rho = (9.6 \times 1 \times 10^{-7}) / 1 \times 10^{-6} = 0.96 \text{ m}$$

Electrical energy and power

In summary, electrical power consumed by an electrical appliance is given by;

$$P = V I$$

$$P = I^2 R$$

$$P = V^2 / R$$

The SI unit for power is the watt (**W**)

$$1 \text{ W} = 1 \text{ J/s and } 1 \text{ kW} = 1,000 \text{ W.}$$

Examples

1. What is the maximum number of 100 W bulbs which can be safely run from a 240 V source supplying a current of 5 A?

Solution

Let the maximum number of bulbs be 'n'. Then $240 \times 5 = 100 n$

So 'n' = $(240 \times 5) / 100 = 12$ bulbs.

2. An electric light bulb has a filament of resistance 470 Ω . The leads connecting the bulb to the 240 V mains have a total resistance of 10 Ω . Find the power dissipated in the bulb and in the leads.

Solution

$R_{eq} = 470 + 10 = 480 \Omega$, therefore $I = 240 / 480 = 0.5 \text{ A}$.

Hence power dissipated = $I^2 R = (0.5)^2 \times 470 = 117.5 \text{ W}$ (bulb alone)

For the leads alone, $R = 10 \Omega$ and $I = 0.5 \text{ A}$

Therefore power dissipated = $(0.5)^2 \times 10 = 2.5 \text{ W}$.

Applications of heating of electrical current

- Filament lamp** – the filament is made up of tungsten, a metal with high melting point (3,400 °C). It is enclosed in a glass bulb with air removed and argon or nitrogen injected to avoid oxidation. This extends the life of the filament.
- Fluorescent lamps** – when the lamp is switched on, the mercury vapour emits ultra violet radiation making the powder in the tube fluoresce i.e. emit light. Different powders emit different colours.

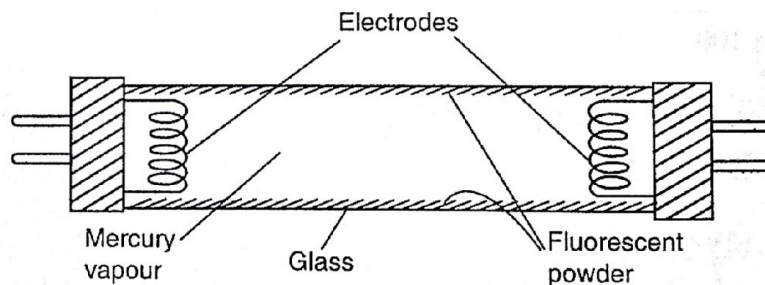

3. **Electrical heating** – electrical fires, cookers e.tc. their elements are made up nichrome (alloy of nickel and chromium) which is not oxidized easily when it turns red hot.

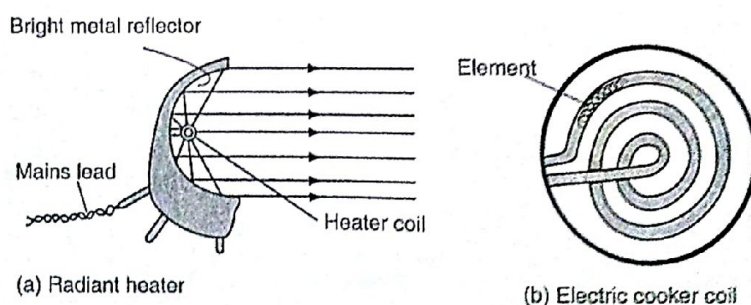

4. **Fuse** – this is a short length of wire of a material with low melting point (often thinned copper) which melts when current through it exceeds a certain value. They are used to avoid overloading.

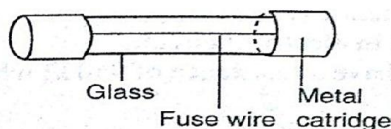

CHAPTER NINE QUANTITY OF HEAT

Heat is a form of energy that flows from one body to another due to temperature differences between them.

Heat capacity

Heat capacity is defined as the quantity of heat required to raise the temperature of a given mass of a substance by one degree Celsius or one Kelvin. It is denoted by 'C'.

Heat capacity, $C = \text{heat absorbed, } Q / \text{temperature change } \theta$.

The units of heat capacity are $\text{J} / ^\circ\text{C}$ or J / K .

Specific heat capacity.

S.H.C of a substance is the quantity of heat required to raise the temperature of 1 kg of a substance by 1°C or 1 K. It is denoted by 'c', hence,

$c = Q / m \theta$ where Q – quantity of heat, m – mass and θ – change in temperature.

The units for 'c' are $J kg^{-1} K^{-1}$. Also $Q = m c \theta$.

Examples

1. A block of metal of mass 1.5 kg which is suitably insulated is heated from $30^{\circ}C$ to $50^{\circ}C$ in 8 minutes and 20 seconds by an electric heater coil rated 54 watts. Find;
 - a) The quantity of heat supplied by the heater
 - b) The heat capacity of the block
 - c) Its specific heat capacity

Solution

a) Quantity of heat = power \times time = $P t$
 $= 54 \times 500 = 27,000 J$

b) Heat capacity, $C = Q / \theta = 27,000 / (50 - 30) = 1,350 J Kg^{-1} K^{-1}$

c) Specific heat capacity, $c = C / m = 1,350 / 1.5 = 900 J Kg^{-1} K^{-1}$

2. If 300 g of paraffin is heated with an immersion heater rated 40 W, what is the temperature after 3 minutes if the initial temperature was $20^{\circ}C$? (S.H.C for paraffin = $2,200 J Kg^{-1} K^{-1}$).

Solution

Energy = $P t = m c \theta = Q =$ quantity of heat.

$P t = 40 \times 180 = 7,200 J$

$m = 0.30 kg$ $c = 2,200$, $\theta = ..?$

$Q = m c \theta$, $\theta = Q / m c = 7,200 / (0.3 \times 2,200) = 10.9^{\circ}C$

3. A piece of copper of mass 60 g and specific heat capacity $390 J Kg^{-1} K^{-1}$ cools from $90^{\circ}C$ to $40^{\circ}C$. Find the quantity of heat given out.

Solution

$Q = m c \theta$, $= 60 \times 10^{-3} \times 390 \times 50 = 1,170 J$.

Determination of specific heat capacity

A calorimeter is used to determine the specific heat capacity of a substance. This uses the principle of heat gained by a substance is equal to the heat lost by another substance in contact with each other until equilibrium is achieved. Heat losses in calorimeter are controlled such that no losses occur or they are very minimal.

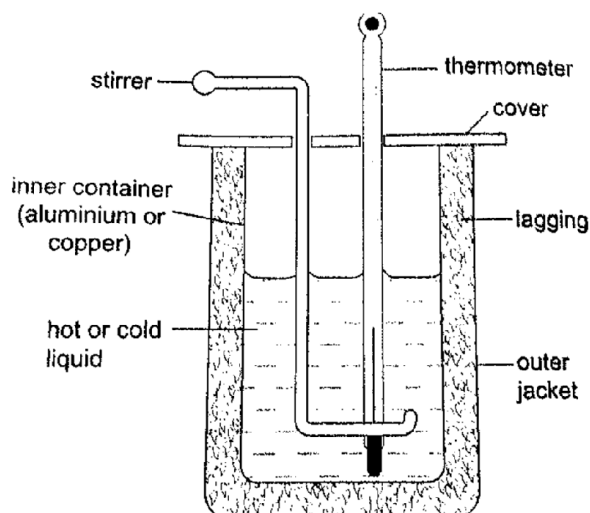

Examples

1. A 50 W heating coil is immersed in a liquid contained in an insulated flask of negligible heat capacity. If the mass of the liquid is 10 g and its temperature increases by 10 °C in 2 minutes, find the specific heat capacity of the liquid.

Solution

$$\text{Heat delivered (P t)} = 50 \times 2 \times 60 = 2,400 \text{ J}$$

$$\text{Heat gained} = 0.1 \times c \times 10 \text{ J}$$

$$\text{Therefore 'c'} = 2,400 / 0.1 \times 10 = 2,400 \text{ J Kg}^{-1} \text{ K}^{-1}$$

2. A metal cylinder mass 0.5 kg is heated electrically. If the voltmeter reads 15V, the ammeter 0.3A and the temperatures of the block rises from 20 °C to 85 °C in ten minutes. Calculate the specific heat capacity of the metal cylinder.

Solution

$$\text{Heat gained} = \text{heat lost, } V I t = m c \theta$$

$$15 \times 0.3 \times 10 \times 60 = 0.5 \times c \times 65$$

$$c = (15 \times 0.3 \times 600) / 0.5 \times 65 = 831 \text{ J Kg}^{-1} \text{ K}^{-1}$$

Fusion and latent heat of fusion

Fusion is the change of state from solid to liquid. Change of state from liquid to solid is called solidification. **Latent heat of fusion is the heat energy absorbed or given out during fusion.**

Specific latent heat of fusion of a substance is the quantity of heat energy required to change completely 1 kg of a substance at its melting point into liquid without change in temperature.

It is represented by the symbol (**L**), we use the following formula,

$$Q = m L_f$$

Different substances have different latent heat of fusion.

Factors affecting the melting point

- a) Pressure

b) *Dissolved substances*

Specific latent heat of vaporization is the quantity of heat required to change completely 1 kg of a liquid at its normal boiling point to vapour without changing its temperature. Hence

$$Q = m L_v$$

The SI unit for specific latent heat of vaporization is **J / Kg**.

Example

An immersion heater rated 600 W is placed in water. After the water starts to boil, the heater is left on for 6 minutes. It is found that the mass of the water had reduced by 0.10 kg in that time. Estimate the specific heat of vaporization of steam.

Solution

Heat given out by the heater = $P t = 600 \times 6 \times 60$

Heat absorbed by steam = $0.10 \times L_v$

Heat gained = heat lost, therefore, $600 \times 6 \times 60 = 0.10 \times L_v = 2.16 \times 10^6 \text{ J / Kg}$

Evaporation

Factors affecting the rate of evaporation

- Temperature
- Surface area
- Draught (hot and dry surrounding)
- Humidity

Comparison between boiling and evaporation

Evaporation

- Takes place at all temperature
- Takes place on the surface (no bubbles formed)
- Decrease in atmospheric pressure increases the rate

Boiling

- takes place at a specific temperature
- takes place throughout the liquid (bubbles formed)
- decreases as atmospheric pressure lowers

Applications of cooling by evaporation

- Sweating
- Cooling of water in a porous pot
- The refrigerator

CHAPTER TEN THE GAS LAWS

Pressure law

This law states that “**the pressure of a fixed mass of a gas is directly proportional to the absolute temperature if the volume is kept constant**”. The comparison between Kelvin scale and degrees Celsius is given by; $\theta^\circ = (273 + \theta) \text{ K}$, and $T (\text{K}) = (T - 273)^\circ \text{C}$.

Examples

- A gas in a fixed volume container has a pressure of $1.6 \times 10^5 \text{ Pa}$ at a temperature of 27°C . What will be the pressure of the gas if the container is heated to a temperature of 277°C ?

Solution

Since law applies for Kelvin scale, convert the temperature to kelvin

$$T_1 = 27^\circ\text{C} = (273 + 27) \text{ K} = 300 \text{ K}$$

$$T_2 = 227^\circ\text{C} = (273 + 227) = 550 \text{ K}$$

$$P_1 / T_1 = P_2 / T_2, \text{ therefore } P_2 = (1.6 \times 10^5) \times 550 / 300 = 2.93 \times 10^5 \text{ Pa.}$$

2. At 20°C , the pressure of a gas is 50 cm of mercury. At what temperature would the pressure of the gas fall to 10 cm of mercury?

Solution

$$P / T = \text{constant}, P_1 / T_1 = P_2 / T_2, \text{ therefore } T_2 = (293 \times 10) / 50 = 58.6 \text{ K or } (-214.4^\circ\text{C})$$

Charles law

Charles law states that “**the volume of a fixed mass of a gas is directly proportional to its absolute temperature (Kelvin) provided the pressure is kept constant**”. Mathematically expressed as follows,

$$V_1 / T_1 = V_2 / T_2$$

Examples

1. A gas has a volume of 20 cm^3 at 27°C and normal atmospheric pressure. Calculate the new volume of the gas if it is heated to 54°C at the same pressure.

Solution

$$\text{Using, } V_1 / T_1 = V_2 / T_2, \text{ then } V_2 = (20 \times 327) / 300 = 21.8 \text{ cm}^3.$$

2. 0.02 m^3 of a gas is at 27°C is heated at a constant pressure until the volume is 0.03 m^3 . Calculate the final temperature of the gas in $^\circ\text{C}$.

Solution

$$\text{Since } V_1 / T_1 = V_2 / T_2, T_2 = (300 \times 0.03) / 0.02 = 450 \text{ K Or } 177^\circ\text{C}$$

Boyle’s law

Boyle’s law states that “**the pressure of a fixed mass of a gas is inversely proportional to its volume provided the temperature of the gas is kept constant**”. Mathematically expressed as,

$$P_1 V_1 = P_2 V_2$$

Examples

1. A gas in a cylinder occupies a volume of 465 ml when at a pressure equivalent to 725 mm of mercury. If the temperature is held constant, what will be the volume of the gas when the pressure on it is raised to 825 mm of mercury?

Solution

$$\text{Using, } P_1 V_1 = P_2 V_2, \text{ then } V_2 = (725 \times 465) / 825 = 409 \text{ ml.}$$

2. The volume of air 26 cm long is trapped by a mercury thread 5 cm long as shown below. When the tube is inverted, the air column becomes 30 cm long. What is the value of atmospheric pressure?

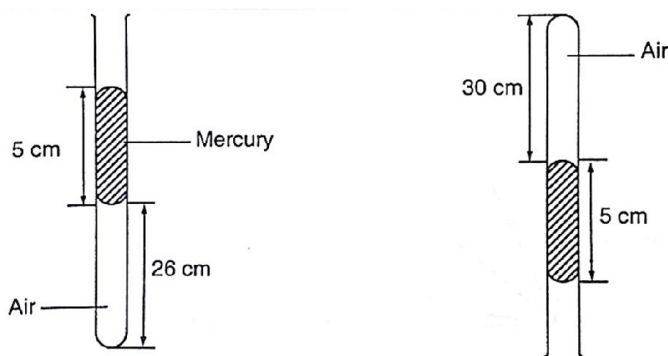

Solution

Before inversion, gas pressure = atm. Pressure + $h p g$

After inversion, gas pressure = atm. Pressure - $h p g$

From Boyle's law, $P_1 V_1 = P_2 V_2$, then let the atm. Pressure be 'x',

$$\text{So } (x + 5) 0.26 = (x - 5) 0.30$$

$$0.26x + 1.30 = 0.3x - 1.5, x = 2.8 / 0.04 = 70 \text{ cm.}$$

A general gas law

Any two of the three gas laws can be used derive a general gas law as follows,

$$P_1 V_1 / T_1 = P_2 V_2 / T_2 \text{ or}$$

$P V / T = \text{constant}$ – equation of state for an ideal gas.

Examples

1. A fixed mass of gas occupies $1.0 \times 10^{-3} \text{ m}^3$ at a pressure of 75 cmHg. What volume does the gas occupy at 17.0°C if its pressure is 72 cm of mercury?

Solution

$$P V / T = \text{constant so } V_1 = (76 \times 1.0 \times 10^{-3} \times 290) / 273 \times 72 = 1.12 \times 10^{-3} \text{ m}^3.$$

2. A mass of $1,200 \text{ cm}^3$ of oxygen at 27°C and a pressure 1.2 atmosphere is compressed until its volume is 600 cm^3 and its pressure is 3.0 atmosphere. What is the Celsius temperature of the gas after compression?

Solution

$$\text{Since } P_1 V_1 / T_1 = P_2 V_2 / T_2, \text{ then } T_2 = (3 \times 600 \times 300) / 1.2 \times 1,200 = 375 \text{ K or } 102^\circ\text{C.}$$

===== THE END =====