

**WESTLANDS JOINT EXAMINATION**

Kenya Certificate of Secondary Education

232/1

**PHYSICS**

Paper 1

July / August 2015

**SECTION A (25 marks)**

Answer ALL the questions in the spaces provided.

1. State the smallest measurement that can be made by the micrometer screw gauge. (1 mark)
2. The diagram below shows a section of a micrometer screw gauge.

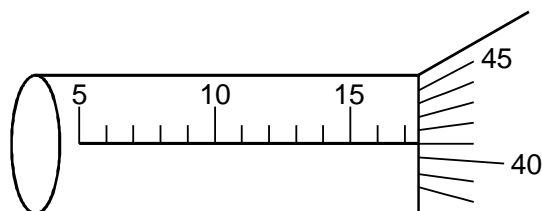

- ii) The thimble of the micrometer screw gauge is rotated through two and half revolutions in the clockwise direction in order to measure the diameter of a marble. State the diameter of the marble if the instrument had a negative error of 0.03mm. (2 marks)
3. State one factor that would affect surface tension of pure water in a beaker of water. (1 mark)
4. The diagram below shows apparatus used to observe the behaviour of smoke particle in air.

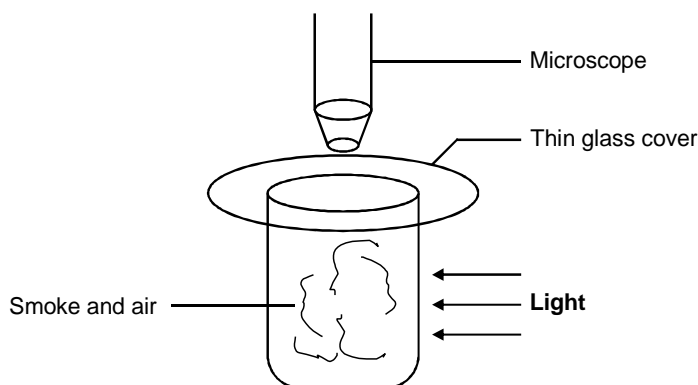

- i) Why are smoke particles suitable for use in this experiment. (1 mark)
- ii) What does the experiment tell you about the behaviour of the air molecules in the cell? (1 mark)
- iii) What difference if any would be seen in the motion of the smoke particles if a weaker light was used. (1 mark)
5. In the evening the inside of green houses may be seen to have water droplets on them. Why does this happen? (1 mark)
6. When a particular substance at a certain temperature is heated, it expands. When the same substance at the same temperature is cooled, it also expands. (2 marks)
- a) What is the substance?
- b) What is the temperature?
7. A block of metal of mass 0.20kg and temperature 100°C is placed in water of mass 0.42g and temperature 21°C. If the final temperature of the water is 25°C, calculate the specific heat capacity of the metal. (Neglect heat absorbed by the container, take specific heat capacity of water 4200J/kg k.) (3 marks)
8. The spring is fitted with a scale pan as shown in the figure below and the pointer points to the 30cm mark on the scale. When some sand is placed in the pan the pointer points to 15cm mark.

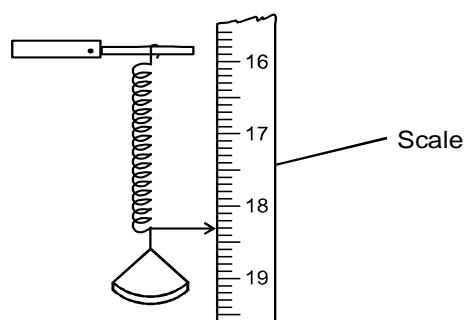

- When a 20g mass is placed on top of the sand the pointer points to 5.0cm mark.
- a) What extension is produced by the sand?
- b) What extension is produced by the 20g mass?
- c) What is the mass of the sand? (3 marks)

9. Define the term centre of gravity of a body. (1 mark)
10. A uniform half metre rule is pivoted at the 15cm mark and it balances when a mass of 40g is hung from the 2cm mark. Calculate the mass of the rule. (2 marks)
11. A machine of velocity ratio of 50N overcomes a load of  $4.5 \times 10^3$  N when the effort of 120W is applied.  
 i) Find the efficiency of the machine. (2 marks)  
 ii) It is observed that the efficiency of the machine increase when it is used to lift large load. Give a reason for this (1 mark)
12. Figure below shows a fluid flowing in a tube.

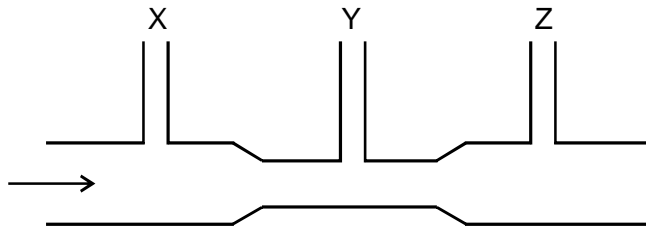

Show on the diagram the relative position of the levels of the liquid in section marked X, Y Z. (3 marks)

### SECTION B (55 marks)

Answer ALL the questions in this section in spaces provided.

I.

- a) The diagram below shows a set up used by a student to show variation of pressure in a liquid. Use it to answer the question that follow.

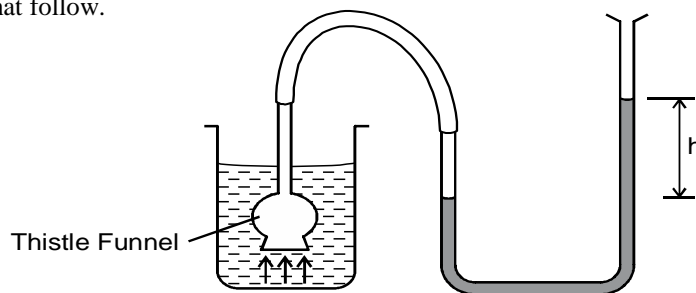

State and explain the effect on the height, h, when the thistle funnel is moved upwards towards the surface of the liquids. (2 marks)

- b) Figure below shows a simple barometer.

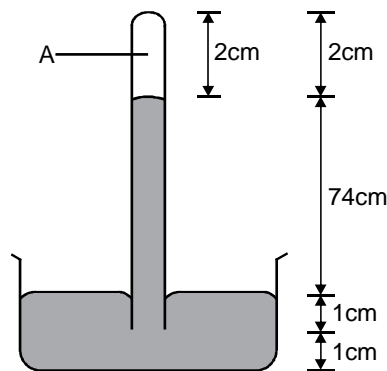

- a) What is the region A? (1 mark)  
 b) What keeps the mercury in the tube? (1 mark)  
 c) What is the value of the atmospheric pressure being shown by the barometer? (1 mark)  
 d) What would happen to the reading if the barometer were taken up a high mountain. (1 mark)  
 e) Give a reason for (d) above. (1 mark)
- II. a) In opening a door, the moment exerted about the hinges was 15Nm. If the pushing force was 25N and perpendicular to the door, what is the distance of the force from the hinges? (2 marks)  
 b) A uniform plank of wood is balanced 30cm from one end when a lead of 0.08kg is hung at one end as shown below.

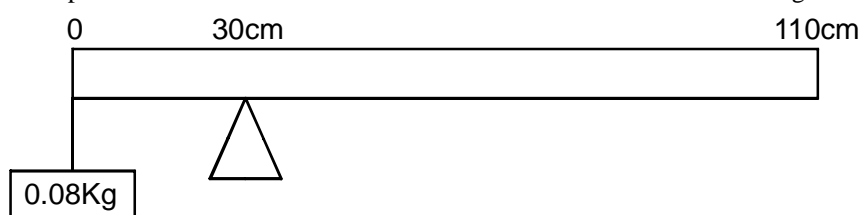

- Calculate the weight of the plank. (2 marks)
- c) State two factors that affect centre of gravity. (1 mark)
14. a) Sketch a velocity-time graph of a ball dropped to the ground and caught when it bounces up again. (2 marks)

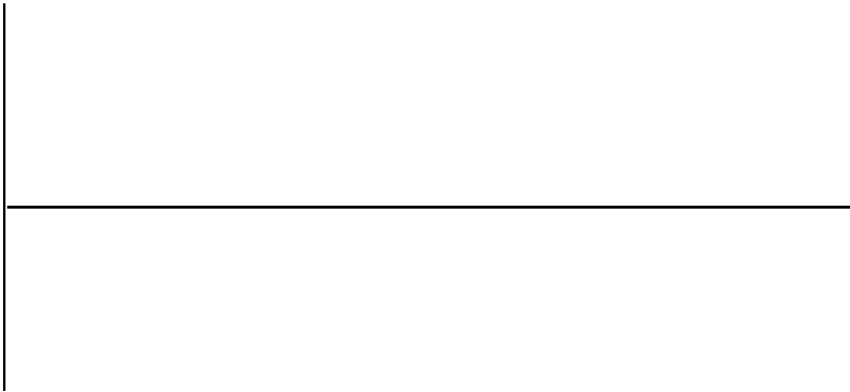

- b) In areas of the world where a plane is unable to land free fall airdrops can be used to deliver supplies. A plane travelling at a speed of 90m/s and a height of 100m releases a load of supplies.
- i) Sketch the path followed by the falling load. (1 mark)
- ii) Find the horizontal distance of the load from the drop zone to where it landed. (3 marks)
- c) Define the Newton. (1 mark)
- d) The reading on a speedometer of a car of mass 1000kg is 60km/hr when the brakes are applied. The car is brought to rest in 10m.
- Find
- i) the retardation. (2 marks)
- ii) find the average braking force. (2 marks)
- 15.a) The figure below shows the motion of a ticker tape through a ticker-timer whose frequency is 100Hz.

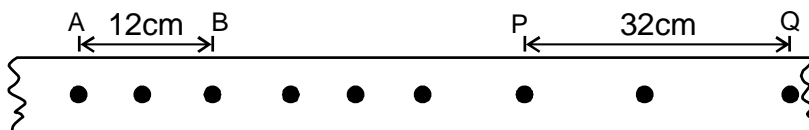

Determine:

- I. Velocity at AB and PQ (2 marks)
- II. Acceleration of the tape. (2 marks)
- b) State two factors that affect centripetal force of a body moving a circular path. (2 marks)
- c) A stone of mass 1.2 kg is tied to a rope and whirled in a vertical circle of radius 3.2m with a speed of 6.32m/s. Calculate
- i) The centripetal acceleration of the stone. (2 marks)
- ii) The tension in the rope when the stone is at the highest point. (2 marks)
16. a) State the law of floatation. (1 mark)
- b) You are provided with the following
- A block of wood.
  - A spring balance
  - A thin thread.
  - Overflow can
  - A small measuring cylinder.
  - Some liquid.
- With the aid of a labelled diagrams describe an experiment to verify the law of floatation. (4 marks)
- c) A block of length 80cm, cross sectional area 3.0cm<sup>2</sup> and density 1300kg/m<sup>3</sup> is completely immersed in a liquid of density 1030kg/m<sup>3</sup>. Determine
- i) The mass of the block. (1 mark)
- ii) The weight of the block in the liquid. (3 marks)
- d) The diagram below shows a car acid hydrometer.

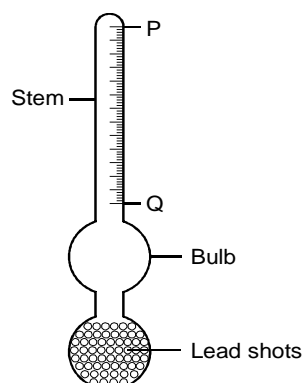

- i) Indicate on the diagram the maximum and minimum measurements to be taken. (1 mark)  
 ii) State the reason why the bulb is wide. (1 mark)
17. a)  
 i) State Charles law. (1 mark)  
 ii) A gas of volume  $2\text{m}^3$  at  $27^\circ\text{C}$  is cooled to  $-123^\circ\text{C}$ , at constant pressure. What is its new volume? (2 marks)

b)

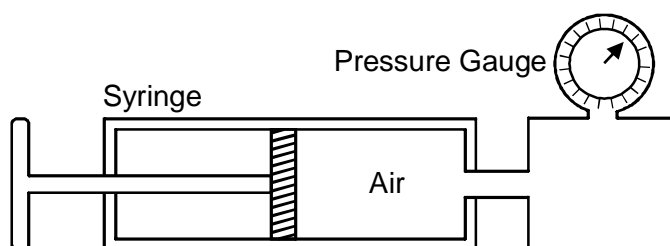

The figure shown illustrates an apparatus in which a fixed mass of air was compressed in a calibrated syringe, which was approximately half full of air at atmospheric pressure and a temperature of  $17^\circ\text{C}$  corresponding values of volume and pressure of the trapped air as shown in the table.

Pressure (Kpa)	50	60	75	90	105	120
Volume ( $\text{cm}^3$ )	0.00048	0.00040	0.00032	0.00027	0.00023	0.00020
$\frac{1}{\text{Volume}}$		2500		3704		

(1 mark)

- i) Complete the table by calculating values for  $\frac{1}{\text{Volume}}$  some of the values have been entered for you.  
 ii) On grid paper plot a graph of pressure on the y-axis against  $\frac{1}{\text{Volume}}$  on the axis. (5 marks)  
 iii) What relationship between pressure and volume of the trapped air can be deduced from your graph? Explain your answer. (1 mark)  
 iv) If the temperature of air was increased to  $27^\circ\text{C}$ , what volume would be occupied by the air at a pressure of  $100\text{Kpa}$ ? (1 mark)

**WESTLANDS JOINT EXAMINATION**  
 Kenya Certificate of Secondary Education  
 232/2  
**PHYSICS**  
**Paper 2**

**SECTION A (25 marks)**

Answer ALL questions in this paper

1. Figure 1 below shows a ray of light incident to the first of the two mirrors placed at an angle of  $60^\circ$ .

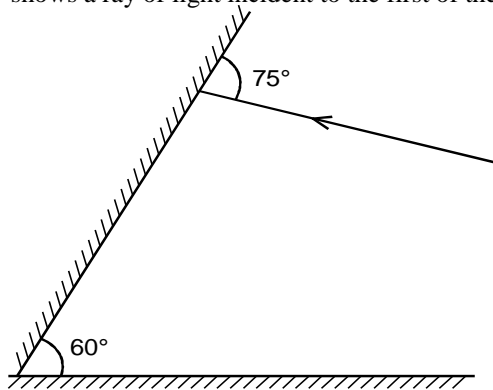

- Complete the part of the ray after reflection from the mirrors. (2 marks)
2. A concave mirror produces a real image 2cm tall of an object 5.0mm tall placed 10cm from the mirror. Find the focal length of the mirror. (2 marks)
3. a) The figure below shows a positive charge near a plate carrying negative charge.

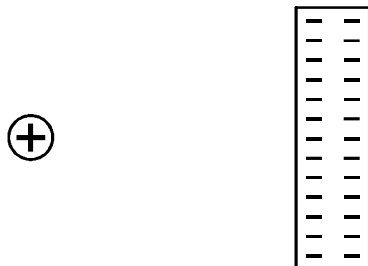

Draw an electric field pattern between them

(1 mark)

- b) Calculate the effective capacitance in the diagram below.

(2 marks)

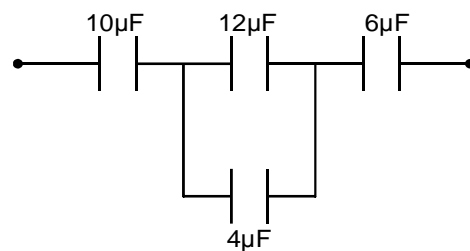

4. Two pins are hanging from a magnet as shown in the diagram below.

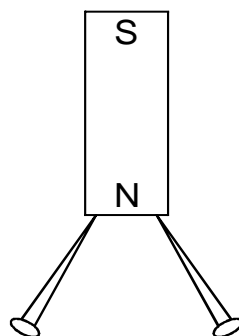

- Explain why they do not hang vertically downwards. (2 marks)
5. i) Arrange the following waves in order of decreasing wavelength.  
Infrared, X-rays, microwaves, yellow light, radio waves, red light. (1 mark)
- ii) State one application of visible light.
6. The figure below shows an arrangement for lighting three lamps, A, B and C only one of which is controlled directly by the switch.

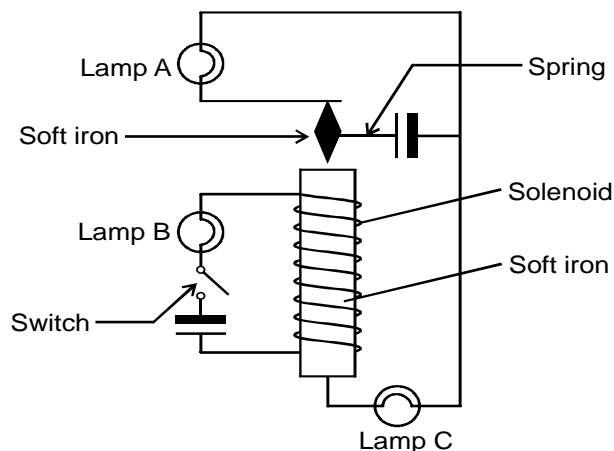

- a) Which of the lamp is directly controlled by the switch? (1 mark)
- b) What is the name given to this use of an electromagnet? (1 mark)
- c) Which lamps can be on at once? (1 mark)
- d) Explain how lamp C comes in. (1 mark)
7. A power line from a power sub-station to a town a few kilometres away has a resistance of 0.1 Ohm per kilometre. Determine the rate of energy loss is transmission of power over 50km at a current of 60 amperes. (2 marks)
8. a) A battery rated 80Ah. What does this mean. (1 mark)
- b) Sketch the diagram of a simple cell. (1 mark)
9. Describe the energy changes that occurs in the cathode ray tube. (1 mark)
10. Why is a point source of X-rays needed to produce X-ray shadow photographs. (2 marks)
11. State one factor that affects the velocity of sound in air. (1 mark)
12. Give an expression which can be used to calculate electrical energy. (1 mark)

### SECTION B - ( 55 marks)

Answer ALL questions in the spaces provided

13. Ultraviolet radiation incident on a zinc plate releases electrons from the zinc surface . The energy of each incident photon is 5.4eV, zinc has work function of 4.3eV.
- a) i) State the name given to this effect. (1 mark)
- ii) What is meant by work function of the metal? (1 mark)
- b) An electron is emitted from the surface of zinc
- i) Calculate the maximum kinetic energy of the electron in Joules. (3 marks)
- ii) Calculate the maximum speed of the electron. (2 marks)
- c) Name two devices that uses photoelectric effect. (2 marks)
- d) The figure shows zinc plate placed on the cap of a negatively charged electroscope. Ultraviolet radiation is made to fall on the plate.

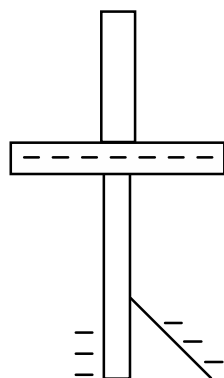

- i) What happens the leaf of electroscope. (1 mark)
- ii) What would happen if the radiation was red light. (1 mark)
14. a) Explain what is meant by
- i) half-life. (1 mark)

- ii) background radiation. (1 mark)
- b) At a certain instant the corrected count-rate registered on a detector placed close to an  $\alpha$ -particle emitter is 200 per second and this falls to 50 per second in 12 minutes. Determine the half-life of the source. (2 marks)
- c) The following represents part of a radioactive series in which the chemical symbols have been replaced by letters.

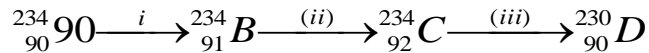

Name the particles emitted in the three changes. (3 marks)

Write down the two letters which represent isotopes. (1 mark)

- d) A doctor suspects that one of the kidneys of a patient is not working properly. The doctor injects him with a radioactive impurity, 1 MBq of iodine-131 (half-life 8 days) which travels to his kidneys. A normal kidney gradually removes all impurity from the blood in about 20 minutes. The radioactivity in his kidney is monitored, using gamma ray detectors. The graph below shows the results.

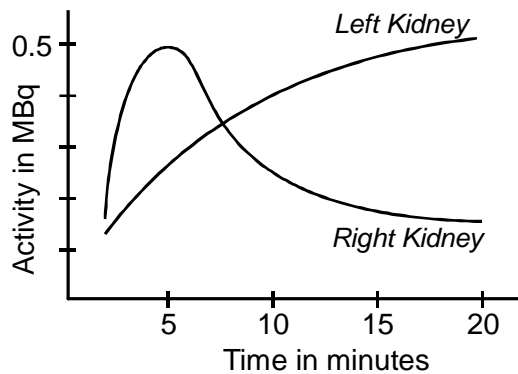

- a) Which kidney do you think is not working properly? Explain your answer. (1 mark)
- b) Why do you think that a gamma ray emitter was used as the injected impurity instead of a beta emitter? (1 mark)
- c) Why would it be less suitable to use as an impurity a material with a very short half-life? (1 mark)

15.

- I. a) Distinguish between intrinsic and extrinsic semi-conductors. (1 mark)
- b) State two uses of a junction diode. (2 marks)
- c) The graph in the figure below shows a forward bias characteristics of a P-N junction.

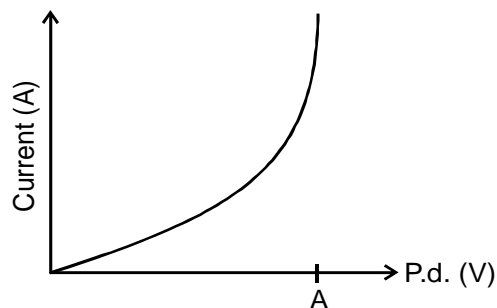

The depletion layer decreases from O to A. Explain what is meant by depletion layer. (1 mark)

- d) The figure below shows a P - N junction.



Complete the diagram so that the function is reverse biased. (1 mark)

- II. a) State the Lenz's law of electromagnetic induction. (1 mark)

- b) A wire placed between the poles of two permanent magnets is connected to a galvanometer as shown below.

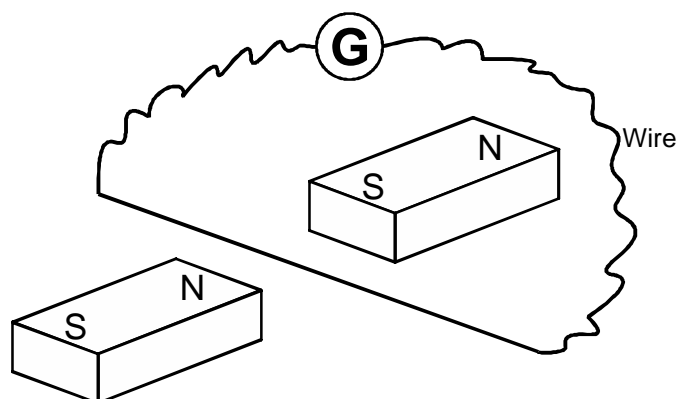

- State what is observed when the wire is moved up and down. (1 mark)
- c) Suggest two ways of increasing the magnitude of the effect you have stated in (b) above. (2 marks)
- d) Define the term mutual induction. (1 mark)
16. a) i) State two conditions necessary for total internal reflection. (2 marks)
- ii) Define the critical angle. (1 mark)
- iii) Calculate the critical angle of a solid given that its refractive index is 2.21. (2 marks)
- iv) Calculate the angle of incidence of a ray of light on one face of a  $60^\circ$  prism if the ray is just totally internally reflected on meeting the next face (refractive index of glass is 1.5) (2 marks)
- b) i) Name the part of the eye which changes the focal length of the eye. (1 mark)
- ii) A small object is placed 30cm away from a diverging lens of focal length 10cm. Determine by scale drawing the position and nature of image formed. (4 marks)
17. a) Describe, giving a circuit diagram, an experiment which would show how to determine the internal resistance of a cell and E.m.f. indicate briefly what readings would be needed in order to estimate its values. (2 marks)
- b) The following readings were obtained from a similar experiment.

Voltmeter reading (V)	1.35	1.4	1.45	1.5	1.55
Ammeter reading	0.35	0.30	0.25	0.20	0.18

- Draw an additional table for resistance  $R$  and  $\frac{1}{I}(A^{-1})$  (2 marks)
- Plot a graph of  $R$  against  $\frac{1}{I}$  (5 marks)
- i) Hence determine the gradient. (2 marks)
- ii) Determine the value of  $R$  when the value of  $\frac{1}{I}$  is zero. (1 mark)
- $R =$
- iii) Which quantity is represented by the value of the slope  $S$ ? (1 mark)



**WESTLANDS JOINT EXAMINATION**

Kenya Certificate of Secondary Education

232/3

**PHYSICS****Paper 3****July/August 2015**

1. You are provided with the following :

- One stand
- One boss
- One clamp
- Two pieces of thread
- One stopwatch
- One metre rule or half metre rule
- Two springs.
- Six 100g masses
- A piece of cellotape.

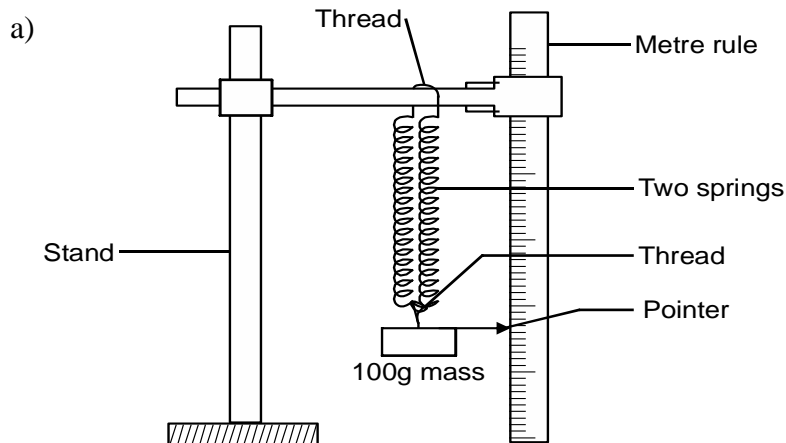

- a) i) Hang the springs from rod of a clamp as shown in the figure above.  
 ii) Tie together the upper end and the lower ends to springs with pieces of thread as shown in the figure.  
 iii) Hang a 100g mass from the lower ends of the springs so that the mass is supported by both springs.  
 iv) Clamp the rule vertically with zero centimetre mark uppermost.  
 v) Use cellotape to fix the optical pin on the top of the 100g mass so that it acts as a pointer.  
 vi) Adjust the rule so that the pointer is at 40.0cm mark from the top of the rule.
- b) i) Add a 100g mass to the first mass. Record the new position of the pointer and the extension,  $e$ , in the table below.  
 ii) Add another 100g mass and record the new position of the pointer and the extension in the table.  
 iii) Repeat b(ii) until the total mass supported by the spring is 600g.
- c) i) Remove the rule. Displace the 600g mass slightly downwards and release it to oscillate vertically.  
 ii) Time 20 oscillations. Record in the table the time,  $t_1$  for 20 oscillations. Repeat this to obtain the average time,  $t$ , and the period of oscillation  $T$ .  
 iii) Repeat (c) (i) and (ii) for 500g, 400g 300g and 200g masses.  
 iv) Find  $T^2$  and complete the table.

Mass (g)	100	200	300	400	500	600
Position of point (cm)	40.0					
Extension, $e$ , cm	0.0					
Time of $t$ , (s)						
20 oscillations $t_2$ (S)						
Average time, $t$ (s)						
Periodic time, $T$ (s)						
$T^2$ (S <sup>2</sup> )						

- d) i) On the grid provided plot a graph of  $T^2$ (vertical axis) against the extension,  $e$ . (5 marks)

- d) ii Determine the gradient of the graph.  
 iii) The equation of the graph is given by

$$T^2 = \frac{4\pi^2}{b}e + c$$

Where b and c are constants.

Determine the value of b.

What does the value of b represent?

(1 mark)

(1 mark)

## 2. PART A

You are provided with the following apparatus.

- Two dry cells.
- Nichrome wire mounted on a mm scale.
- An ammeter.
- Cell holder.
- Voltmeter
- 8 connecting wires.
- Metre rule
- Switch.

Proceed

- a) Connect the circuit as shown in the diagram below.

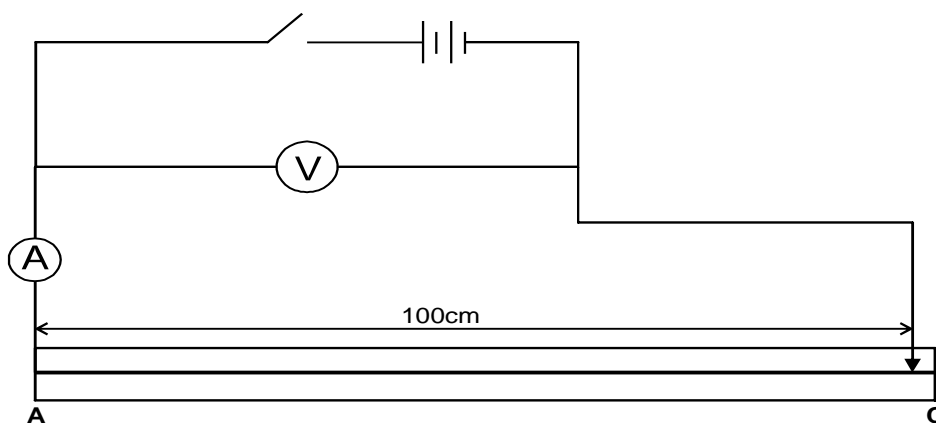

- b) Connect the end A and C where AC is 100cm across the terminals as shown. Close the switch and measure both current I and p.d. across the wire AC.

Current = I .....

(½ mark)

P.d V = .....

(½ mark)

- c) Measure the emf of the cells E = .....

(½ mark)

- d) Reduce the length AC. In each case record the current I and the corresponding V. Complete the table below.

Length L(cm)	100	70	60	50	40	20
Current I (A)						
P.d. (V)						
E - V (v)						

- e) Plot a graph of (E - V) against I (A) (5 marks)  
 f) Determine the slope of the graph. (2 marks)  
 g) Given that  $E = V + Ir$  determine r from your graph. (1½ marks)

## Que 2 PART B

You are provided with the following apparatus.

- Rectangular glass block
- 3 optical pins
- A soft board.
- A plane paper
- 4 paper pins.

Place the rectangular glass block in the middle of the plane paper and trace its outline. Using a pencil remove the block.

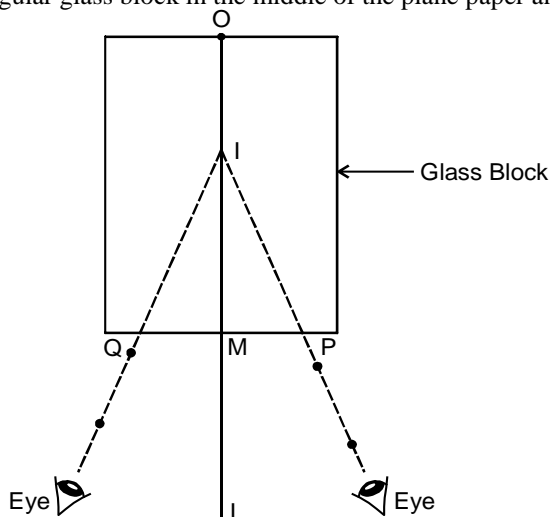

Construct a perpendicular line LMO bisecting the shorter sides of M and O.

Mark points P and Q such that  $PM = MQ = 5\text{cm}$ .

- a) Measure (1 mark)  
 OM.....
- Place the plane paper on the soft board and carefully replace the glass block so that it fit the outline.
  - Press the object pin on O such that it is upright and touching glass block and the second pin on P also upright and touching the block.
  - Press the third pin  $P_1$  a short distance form the block such that  $P_1$ , P and I lie on a straight line when viewed through the block with one eye. I is the image of the object pin O.
  - Repeat the experiment with now on Q. Press the third pin  $P_2$  a short distance from the block such that when viewed  $P_2$ , Q and I lie in a straight line.
- b) Remove the pins and glass block; draw the lines  $P_1P_1I$  (PI dotted) and  $P_2QI$  (QI) dotted meeting OM at I.  
 $IM = \dots\dots\dots\text{cm}$  (1 mark)
- c) Using the above information calculate the refractive index of the glass block by real and apparent depth method. (2 marks)
- d) NB - Hand in your work on the plane paper. (1 mark)

**WESTLANDS JOINT EXAMINATION**

Kenya Certificate of Secondary Education

**PHYSICS**

Paper - 232/1

**MARKING SCHEME**

1. 0.01mm ✓1

2. Reading                    17.00  
                                   + 0.41  
                                   17.41    ✓½  
 After rotation            + 2.05   ✓½  
                                   19.46  
                                   + 0.03  
                                   19.49    = 19.49 mm ✓1

3. Temperature ✓1

4. i) Smoke particles are big enough hence visible ✓1

ii) Air particles are always in motion colliding amongst themselves and also with smoke particles ✓1

iii) Smoke particles will not be visible ✓1

5. Due to cooling of the air inside green house which leads to condensation ✓1

6. a) Water ✓1

b) 4°C ✓1

7. Heat lost by metal =  $0.2 \times C \times (100 - 21)$ Heat gained by H<sub>2</sub>O =  $0.42 \times 4200 (25 - 21)$  $0.2 \times C \times (100 - 21)$  $0.42 \times 4200 \times (25 - 21)$  ✓1 $0.2 \times C \times 79 = 0.42 \times 4200 \times 4$  ✓1 $C = 446.58 \text{ J/kg}$  ✓18. a)  $(15.0 - 5.0\text{cm}) = 10\text{cm}$ b)  $(30\text{cm} - 15) = 15\text{cm}$ c)  $20\text{g} \rightarrow 10\text{cm}$ 

?      15cm

 $\frac{20 \times 15}{10} = 30\text{g}$  ✓1

10

9. It is the point of application of the resultant force due to the earth's attraction on the body.

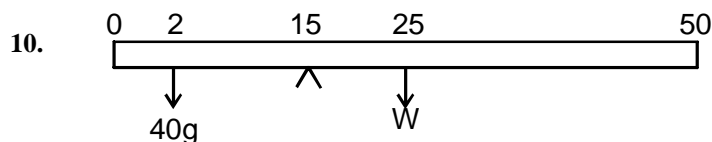

$$F_1 d_1 = F_2 d_2$$

$$\left( \frac{40}{100} \times 10 \right) \times \frac{13}{100} = w \times \frac{10}{100}$$

$$0.4 \times 0.13 = 0.1 w$$

$$w = 0.52\text{N} \Rightarrow \text{mass of metre rule} = 52\text{g}.$$

11. A machine of velocity ratio 50 overcomes a load of  $4.5 \times 10^3\text{N}$ . When the effort is 120N is applied.

i) Find the efficiency of the machine.

$$\text{Ans. } M.A = \frac{4.5 \times 10^3}{120} = 37.5$$

$$\text{Eff.} = \frac{M.A}{V.R} \times 100\%$$

$$\frac{37.5}{50} \times 100\%$$

$$= 75\%$$

ii) As the load increases, weight (pulleys and strings) becomes negligible hence efficiency increases with load. ✓1

12.

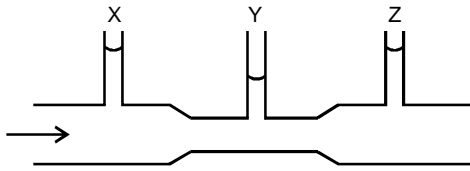

13. I.a)

Height  $h$  decreases / reduces ✓1

This is because pressure in liquids increase with increase in depth, so when you move up pressure reduces. ✓1

b)

i) Vacuum ✓1

ii) Atmospheric pressure ✓1

iii) 74cm ✓1

iv) It will reduce / decrease ✓1

v) At high altitudes atmospheric pressure decrease / low atmosphere pressure.

**II.**a) Moment = force applied  $\times$  perpendicular distance.

$$15Nm = 25 N \times d \quad \checkmark 1$$

$$\frac{15Nm}{25N} = d$$

$$0.6m = d \quad \checkmark 1$$

b) at equilibrium

clockwise moments = anticlockwise moments

$$\frac{30}{100} \times 0.8 \text{ or } = \frac{25}{100} \times w$$

$$24Nm = 25$$

$$\frac{24Nm}{25m} = w$$

$$0.96N = w$$

(should be in Newtons)

c) Base area / base weight ✓1

- Height of the object ✓1

*any 1***SECTION B**

14. a)

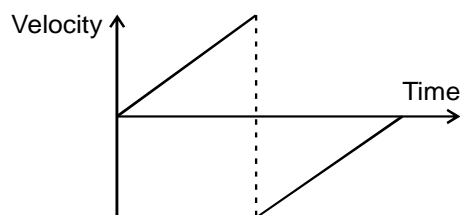

Labelling 1 mark

Shape 1 Mark

b)

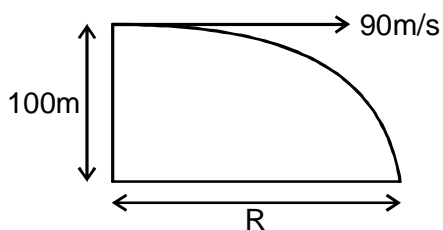
*1 mark*

$$\begin{aligned}
 S &= \frac{1}{2}gt^2 & R &= ut \\
 100 &= \frac{1}{2} \times 10 \times t^2 & &= 90 \times 4.47 \\
 200 &= 10t^2 & &= 402.5m \\
 t &= 4.47 \text{ sec } s
 \end{aligned}$$

c) The force that gives a mass of 1kg an acceleration of  $1m/s^2$  **1 mark**

d)  $60km/hr = \frac{60 \times 1000}{3600} = \frac{50}{3} m/s = u$

$$V = 0 \quad S = 10m$$

$$V^2 = U^2 - 2as$$

$$a = \frac{V^2 - U^2}{2a} = \frac{\left(\frac{50}{3}\right)^2}{20}$$

$$= 13.89m/s^2$$

c) i)  $F = Ma$

$$= 13.89 \times 1000 \checkmark 1$$

$$= 13888.89N \checkmark 1$$

15. a) I.  $t = \frac{1}{100} = 0.01 \text{ seconds}$

$$V_{AB} = \frac{12}{2 \times 0.01} = 600cm/s \text{ or } 6m/s$$

$$V_{PQ} = \frac{32}{2 \times 0.01} = 1600cm/s \text{ or } 16m/s$$

II.

$$a = \frac{V - U}{t}$$

$$= \frac{16 - 6}{6 \times 0.01} = \frac{10}{0.06} = 166.67m/s^2$$

- b)- Mass of the body  
 - Radius of the path  
 - Velocity / speed of motion

**any 2**

c) i)  $a = \frac{r^2}{r}$

$$= \frac{(6.32)^2}{3.2} = 12.482m/s^2$$

ii)  $T_{(\text{minimum})} = \frac{MV^2}{r} - mg$

$$= (1.2 \times 12.482) - (1.2 \times 10)$$

$$= 14.9784 - 12$$

$$= 2.9784N$$

16. a) A floating object displaces its own weight of the fluid in which it floats.

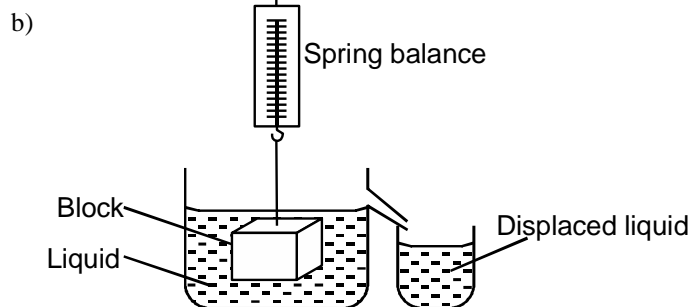

- Measure the weight of block in air ✓1
- Fill Eureka can with liquid and place a measuring cylinder under spout.
- Lower the wood block into the liquid and collect the displaced liquid in the measuring cylinder.
- Repeat to obtain more values.
- Compare the weight of liquid displaced with the weight of block (They are the same)

i)  $V = 80 \times 3 = 240\text{m}^3$

$$m = \rho \times v = 240 \times 1.3 = 312\text{g}$$

$$= 0.312\text{kg}$$

ii) Weight displaced (upthrust)

Apparent weight

$$= (0.312 \times 10) - 2.472$$

$$= 3.12 - 2.472 \quad \checkmark 1$$

$$= 0.648\text{N} \quad \checkmark 1$$

d) i) P = Maximum, Q = minimum ✓1

ii) So that it can displace a large ✓1 of liquid to provide sufficient upthrust is make the hydrometer float ✓1

17.a) The volume of a fixed mass of gas is directly proportional to absolute temperature provided the pressure is kept constant.

ii)  $V_1 = 2\text{m}^3$        $T_1 = (27 + 273) = 300$

$V_2 = ?$        $T_2 = (-123 + 273) = 150$

$$\frac{V_1}{T_1} = \frac{V_2}{T_2}; \quad \frac{2}{300} = \frac{V_2}{150}$$

$$V_2 = \frac{2 \times 150}{300} = 1\text{m}^3$$

b) a) Missing values ; 2083, 3125, 4348

Graph A - 1

S - 1

P - 2

L - 1

b) P is inversely proportional to V.

d)  $0.00025\text{m}^3$

**PHYSICS**

Paper - 232/2

**MARKING SCHEME**

1.

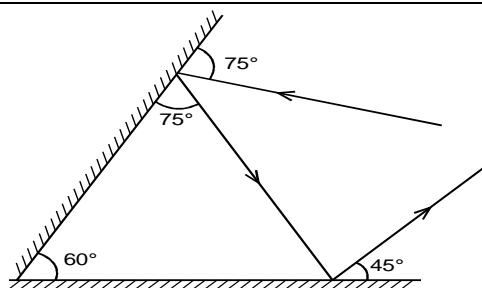

✓1 showing with arrow

✓1 correct angles

2. Magnification

$$\begin{aligned}
 &= \frac{\text{Image height}}{\text{Object height}} & \frac{1}{f} &= \frac{1}{u} + \frac{1}{v} \\
 &= 2\text{cm} & &= \frac{1}{10} + \frac{1}{0.4} \\
 &\quad 50\text{cm} & \frac{1}{f} &= \frac{100 + 4}{40} \\
 M &= 0.04 & f &= \frac{40}{104} \\
 M &= \frac{V}{U} & &= 0.3846 \\
 V &= 0.04 \times 10 & &= 0.4\text{cm} \\
 &= 0.4\text{cm} & &
 \end{aligned}$$

to 1dp

3. a)

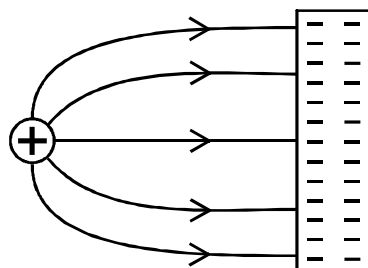

1 mark

b) Parallel  $C = 12 + 4 = 16\mu\text{F}$  ✓1

Effective capacitance

$$\frac{1}{C} = \frac{1}{10} + \frac{1}{16} + \frac{1}{6} = \frac{79}{240}$$

$$C = 3.038\mu\text{F}$$

4. The end of the pins both acquire north poles, ✓1 thus they repel. ✓1

5. i) Radio wave, microwaves, infrared, red light, yellow light, x-ray.

ii) Used in photograph  
Enables the eye to see.

6. a) Lamp B ✓1

b) Magnetic relay ✓1

c) B and C ✓1

d) When soft iron in the solenoid is magnetised, it attracts the soft iron ✓1

$$R = \frac{0.152}{\text{km}} \times 50\text{km} = 50\Omega$$

$$\text{Power loss} = I^2 R = (60)^2 \times 50$$



7.

2 marks

8. a) A battery is rated 80Ah. What does this mean?  
 ANS It can supply a current of 80A for one hour or 8 Amperes in 10 hours  
 b) Sketch a diagram of a simple cell. **1 mark**

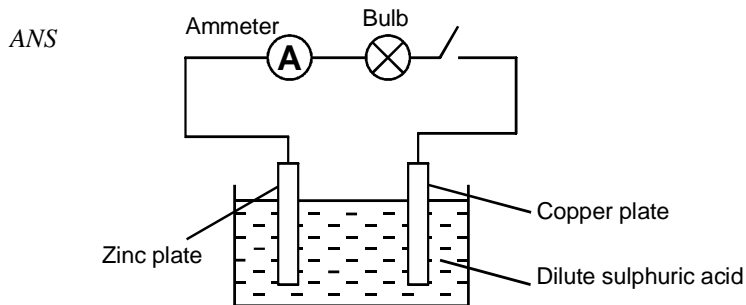

9. Describe the energy changes that occur in the cathode ray tube. **1 mark)**  
 ANS Electrical to light energy
10. Why is a point source of X-rays needed to produce X-ray shadow photographs. (2 marks)  
 X - rays travel in straight lines but cannot be focused by lenses. (1 mark)  
 Hence shadows formed by X-rays will have sharp edges only if they come from point source. **1 mark**
11. Temperature  
 Humidity  
 Wind **any 1 mark**
12.  $E = VI t$

or

$$E = P \times t$$

or

$$E = I^2 R T$$

or

$$E = \frac{V^2}{R} t$$

**any 1 mark**

13. Ultra violet radiation incident on zinc plate releases electrons from the zinc surface the energy of each incident photon is 5.4eV. Zinc has work function of 4.3eV
- a) State the name given to this effect. (1 mark)  
 ANS  
 Photoelectric effect.
- b) What is meant by work function of the metal. (1 mark)  
 ANS  
 Minimum energy required to dislodge an electron from the surface of a metal.
- c) An electron is emitted from the surface of zinc

- i) Calculate the maximum kinetic energy of the electron in joules. (3 marks)

$$(5.4eV - 4.3eV) \times 1.6 \times 10^{-19}$$

$$= 1.76 \times 10^{-19} J$$

ANS.

ii) Calculate the maximum speed of the electron. (2 marks)

ANS.

$$K.E = \frac{1}{2} MV^2$$

$$1.76 \times 10^{-19} = \frac{1}{2} \times 9.11 \times 10^{-31} kg \times V^2$$

$$= 6.2 \times 10^5 m/s$$

i) Name two devices that uses photoelectric effect. 2 marks

- Photocell ✓1
- Solar cells ✓1

d) i) The leaf of electroscope falls. ✓1

ii) With red light, there would be no change. ✓1

**SECTION B****14.** Half life : The time taken for half the number of nuclides initially present in a radioactive sample to decay.

OR

Average time taken for the activity to decrease to half of the initial value or the time taken for half of the number of radioactive nuclei present to decay.

Background radiation are the radiation the counter registers as reaching in the absence of a radioactive source.

$$b) \quad 200 c/s \xrightarrow{1T_{\frac{1}{2}}} 100 c/s \xrightarrow{2T_{\frac{1}{2}}} 50 c/s$$

2 half lifes = 12 minutes.

∴ 1 half - lifes = 6 minutes. ✓1

c) i) beta ✓1      (ii) beta ✓1      iii) alpha ✓1

ii)

A and D

(same atomic no. but different No.) ✓1

d) a) Left kidney: fails to remove the impurity in 20 minutes. ✓1

b) Only gamma radiation can pass out through the body to reach the detector. ✓1

e) Half-life must be significantly longer than the time taken for the kidney to function. ✓1

**15.I.**

a) Intrinsic - pure semi conductors.

Extrinsic - pure semi conductors which have been doped. (or with impurities)

b) Used in rectification.

- Use to protect a circuit from damage for the reverse power supply.

- Used as a switch.

- Used in charging batteries using solar panels.

*any 2*

c) Region in a junction diode occupied by uncovered ions which sets up a potential barrier (p.d). It occurs when mobile charge carries from either side of junction recombine.

d)

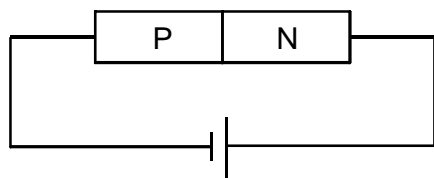
**1 mark for correct terminals of cell.** ✓1**II.**

a) The direction of induced current is always such as to oppose the change producing it. ✓1

b) The galvanometer deflects in one direction when the wire is moved upwards and in the opposite direction when the wire is moved downwards. ✓1

c) - Increasing the strength of the magnet ✓1

- Increasing the speed of motion of the wire. ✓1

d) Is when current in one coil induces current in another coil placed near it. ✓1

16.a)

- i) Light must be travelling from a more optically denser to a less optically dense medium.  
Angle of incidence must be greater than the critical angle.
- ii) Angle of incidence in the optically denser medium for which the angle of refraction in the less dense medium is  $90^\circ$ .

iii)

$$\sin C = \frac{1}{n}$$

$$\sin C = 0.4525$$

$$C = \sin^{-1}(0.4525)$$

$$C = 26.9^\circ$$

iv)

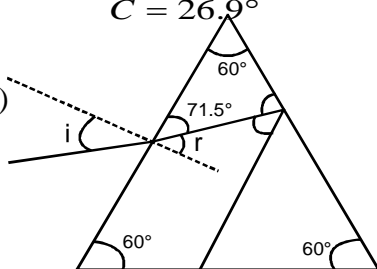

$$\sin C = \frac{1}{n}$$

$$\sin C = 0.6667$$

$$C = 41.8^\circ$$

$$90^\circ = 41.8^\circ$$

$$= 48.2^\circ$$

$$48.2^\circ + 60^\circ = 108.2^\circ$$

$$180 - 108.2^\circ = 71.8^\circ$$

$$\text{Angle of refraction} = 90^\circ - 71.8^\circ$$

$$= 18.2^\circ$$

$$\frac{\sin i}{\sin r} = 1.5$$

$$\sin i = 1.5 \times \sin 18.2^\circ$$

$$\sin i = 0.4685$$

$$i = 27.9^\circ$$

- b) i) Ciliary muscles.

ii)

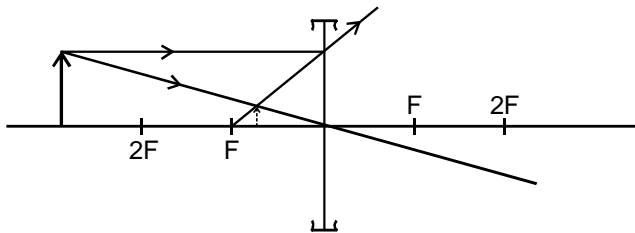
Position  $1.4\text{cm} \pm 0.1$ 

6.5cm - 7.5cm ✓1

Nature

Smaller than object (diminished) ✓½

Between F and optical centre

Virtual ✓½

17. a)

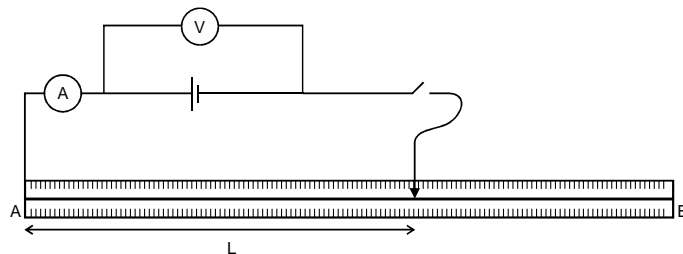

Voltmeter reading (V)	1.5	1.4	1.45	1.5	1.55
Ammeter reading	0.35	0.3	0.25	0.2	0.18

$R = \frac{V}{I}$	3.86	4.67	5.80	7.50	8.60
$\frac{1}{I} (A^{-1})$	2.86	3.30	4.00	5.00	5.56

$$\text{Slope} = \left( \frac{5.8 - 4.6}{4 - 3.3} \right)$$

$$= 1.6V$$

ii)  $R = -1.4 \Omega$

iii) the slope represents E.m.f

### WESTLANDS JOINT EXAMINATION

Kenya Certificate of Secondary Education

### PHYSICS

Paper - 232/3

### MARKING SCHEME

1.

Mass (g)	100	200	300	400	500	600	
Position of point (cm)	40	41.5	43.0	44.5	46.0	47.5	2 marks
Extension, e, cm	0.0	1.5	3.0	4.5	6.0	7.5	$\pm 0.2$ 2 marks
Time of t, (s)		7.31	8.84	10.40	11.31	12.48	$\pm 0.5s$ 1 mark
20 oscillations t <sub>2</sub> (S)		7.34	9.97	10.08	11.33	12.34	1 mark
Average time, t(s)		7.33	9.41	10.24	11.32	12.41	1 mark
Periodic time, T(s)		0.3670	0.4700	0.5120	0.5660	0.6205	2 marks
T <sup>2</sup> (S <sup>2</sup> )		0.1347	0.2209	0.2621	0.3204	0.3850	2 marks

$$\text{Gradient} = \frac{(0.32 - 0.26) s^2}{(6.0 - 4.5) cm}$$

$$= 0.04 S^2 / cm$$

$$T^2 = \frac{4a^2}{b} e + c$$

$$\text{Gradient} = \frac{4a^2}{b}$$

$$0.04 = \frac{4\pi^2}{b}$$

$$b = \frac{4 \times 3.14^2}{0.04} \frac{cm}{s^2}$$

$$= 985.96 cm / s^2$$

$$= 986 cm / s^2$$

b = represents the acceleration due to gravity.  $\checkmark \frac{1}{2}$

### Que 2 - PART A

b) Current  $I = 0.12 \pm 0.01$   $\frac{1}{2}$  mark

$$Pd (V) = 2.6 \pm 0.2 \frac{1}{2} \text{ mark}$$

c)  $E = 3.0 \pm 0.1$   $\frac{1}{2}$  mark

d)

Length L(cm)	100	70	60	50	40	20
Current I (A)	0.12	0.19	0.2	0.23	0.28	0.4
P.d. (V)	2.6	2.5	2.4	2.4	2.3	2.0
E - V (v)						

e) Graph

Labelled axis (both -  $A_1$ )Simple uniform scale -  $S_1$ Plotting -  $\frac{1}{2} \times 4 = P_2$ 

Straight line with positive gradient

Passing through at least 3 correctly plotted points =  $L_1$ 

f) Slope (No line no gradient)

Correct intervals -  $\checkmark 1$ Correct evaluation -  $\checkmark 1$ g)  $r = \text{slope}$   $1$  markAnswer and correct unit  $\frac{1}{2}$  mark**PART B**

OM =  $11.7 \pm 0.2$ cm  $1$  mark

M1 =  $7.8 \pm 0.2$ cm  $1$  mark

index =  $\frac{\text{Real depth}}{\text{apparent depth}}$  =  $\frac{OM}{Im}$   $1$  mark

= OR  $\frac{11.7}{7.8}$

=  $1.50 \pm 0.2$   $1$  mark

Construction  $1$  mark**TOTAL = 5 marks**

**THARAKA SOUTH FORM FOUR JOINT EXAMINATION**

Kenya Certificate of Secondary Education

232/1

**PHYSICS**

Paper 1

**July/August 2015****SECTION A (25 marks)**

Answer ALL the questions in the spaces provided.

1. Figure 1 below shows the reading on a burette after 55 drops of a liquid have been used. If the initial reading was at zero mark, determine the volume of one drop. (2 marks)

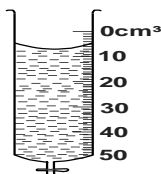

Fig 1

2. A stop watch started 0.5s after the start button was pressed. The time recorded using the stop watch for a ball falling through a liquid was 2.53s. Determine the time of fall. (1 mark)
3. Some water in a tin can was boiled for some time. The can was then sealed and cooled. After some time it collapsed. Explain this observation. (2 marks)
4. A solid weighs 16.5N on the surface of the moon. The force of gravity on the moon is 1.7N/Kg. Determine the mass of the solid. (3 marks)
5. A paper windmill in a horizontal axis was placed above a candle as shown in figure 2 below.



Fig 2

When the candle was lit the paper windmill began to rotate. Explain this observation. (2 marks)

6. When a liquid is heated in a glass flask, its level at first falls, then rises. Explain this observation. (2 marks)
7. Figure 3 shows a uniform rod 4m long and of mass 2kg. It is pivoted 1m from one end and balanced horizontally by a string attached near the other end.

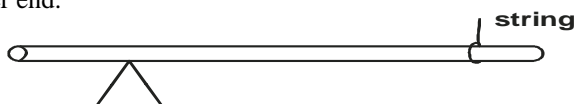

Fig 3

Determine the position where a mass of 5kg should be placed on the rod so that the rod remains horizontal and the tension in the string is zero. (3 marks)

8. Figure 4 shows a uniform cardboard in the shape of a parallelogram.

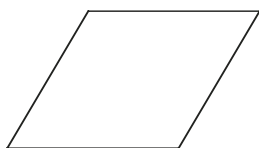

Fig 4

9. Locate the centre of gravity of the cardboard. (1 mark)
- a) An aeroplane is moving horizontally through still air at a uniform speed. It is observed that when the speed of the plane is increased, its height above the ground increases. State the reason for this observation. (1 mark)
- b) Figure 5 shows parts A, B and C of a glass tube.

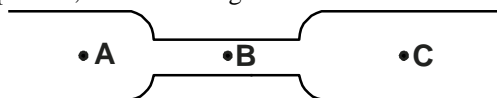

Fig 5

State with reason the part in the tube in which the pressure will be lowest when air is blown through the tube from A towards C. (2 marks)

10. The weight of a solid in air is 5.0N. When it is fully immersed in a liquid of density  $800\text{kgm}^{-3}$ , its weight is 4.04N. Determine
- a) The upthrust in the liquid. (1 mark)
- b) The volume of the liquid. (2 marks)
11. A drop of blue ink is introduced at the bottom of a beaker containing water. It is observed that after some time, all the water in the beaker turns blue. Name the process that takes place. (1 mark)
12. In verifying the pressure law of gasses, the temperature and pressure of a gas are varied at constant volume. State the condition necessary for the law to hold. (1 mark)
13. State the SI unit of a spring constant. (1 mark)

## SECTION B: (55 marks)

14. a) Figure 6 shows a velocity-time graph for the motion of a certain body.

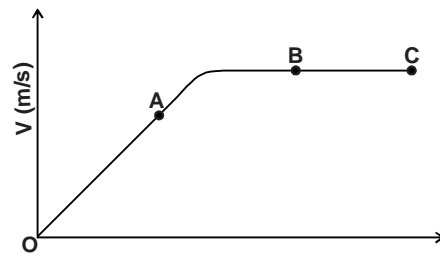

Fig 6

Describe the motion of the body in the region:

- OA. (1 mark)
  - AB (1 mark)
  - BC (1 mark)
- b) A car moving initially at  $10\text{ms}^{-1}$  decelerates at  $2.5\text{ms}^{-2}$ .
- Determine:
    - Its velocity after 1.5 seconds. (2 marks)
    - The distance travelled in 1.5 seconds. (2 marks)
    - The time taken for the car to stop. (2 marks)
  - Sketch the velocity-time graph for the motion of the car up to the time the car stopped. (1 mark)
  - From the graph, determine the distance the car travelled before stopping. (2 marks)
15. a) A horizontal force  $12\text{N}$  is applied on a wooden block of mass  $2\text{kg}$  placed on a horizontal surface. It causes the block to accelerate at  $5\text{m/s}^2$ . Determine the frictional force between the block and the surface. (3 marks)
- b) Figure 7 shows a graph of velocity against time for a ball bearing released at the surface of a viscous liquid.

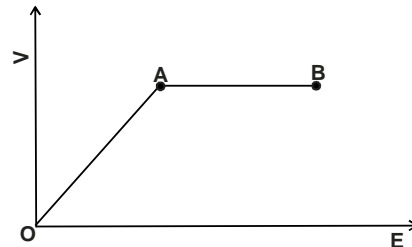

Fig 7

Explain the motion of the ball bearing for parts;

- OA (2 marks)
  - AB (2 marks)
- c) Figure 8 shows a pulley system used to raise a load by applying an effort of  $500\text{N}$ .

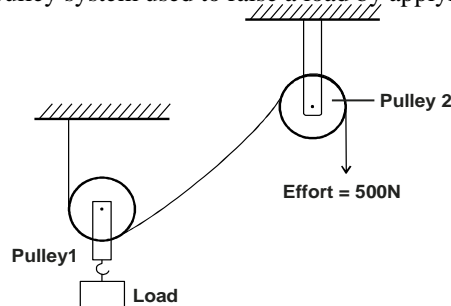

Fig 8

State the

- Velocity ratio of the system. (1 mark)
  - Purpose of pulley 2. (1 mark)
  - Given that the machine has an efficiency of  $80\%$ , determine the maximum load that can be raised. (3 marks)
16. a) An immersion heater rated  $2.5\text{kW}$  is immersed into a plastic jug containing  $2\text{kg}$  of water and switched on for 4 minutes. determine
- the quantity of heat gained by the water. (2 marks)
  - The temperature change for water. (Take specific heat capacity of water as  $4.2 \times 10^3 \text{J Kg}^{-1} \text{K}^{-1}$ ) (3 marks)
- b) Figure 9 shows a horizontal tube containing air trapped by a mercury thread of length  $24\text{cm}$ . The length of the enclosed air column is  $15\text{cm}$ . The atmospheric pressure is  $76\text{cmHg}$ .

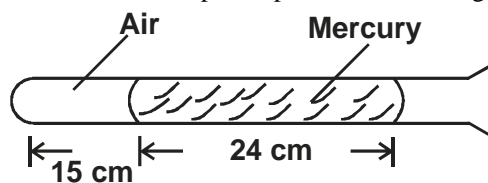
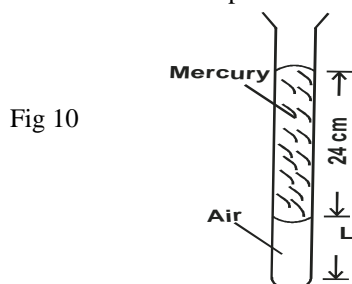

Fig 9

- State the pressure of the enclosed air. (1 mark)

- ii) The tube is now held in a vertical position with the open end facing upwards as shown in figure 10.



Determine:

- The pressure of the enclosed air. (1 mark)
  - The length ( $l$ ) of the enclosed air column. (3 marks)
17. a) State two ways in which the centripetal force on a body of a mass  $m$  can be increased. (2 marks)
- b) Fig 11 shows an object at the end of a light spring balance connected to a peg using a string. The object is moving in a circular path on a smooth horizontal table with a constant speed.

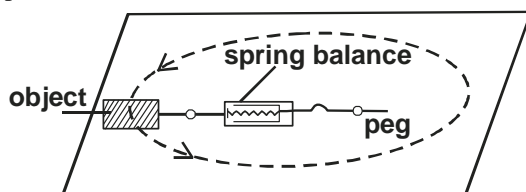

- State what provides the centripetal force. (1 mark)
  - Indicate with an arrow on the figure the direction of the centripetal force. (1 mark)
  - State with a reason why the object is accelerating while the speed remains constant. (1 mark)
  - Given the mass of the object is  $0.5\text{kg}$  and it is moving at a speed of  $8\text{m/s}$  at a radius of  $2\text{m}$ , determine the reading on the spring balance. (3 marks)
- c) Figure 12 shows a frictionless trolley of mass  $2\text{kg}$  moving with uniform velocity towards a wall. At the front of the trolley is a spring whose spring constant is  $25\text{NM}^{-1}$ . The trolley comes to rest momentarily after compressing the spring by  $3\text{cm}$  and then rebounds from the wall.

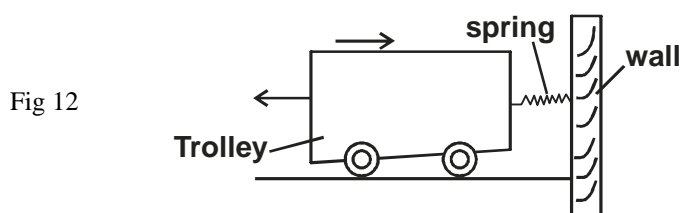

- Determine:
    - The force exerted on the wall by the spring. (3 marks)
    - The maximum acceleration of the trolley as it rebounds from the wall. (3 marks)
    - State the reason why the trolley acquires a constant velocity after it rebounds. (2 marks)
18. Figure 13 shows three stages of an experiment to determine relative density of cork which normally floats on water. To make it sink, a sinker is hung below the cork.

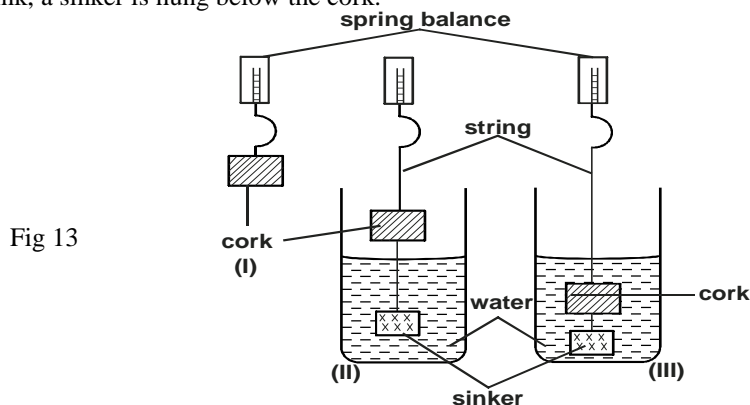

In (I) a spring balance is used to measure the weight  $W$  of the cork in air. In (II) the spring balance is used to measure the apparent weight  $W_1$ , when only the sinker is submerged in water. In (III) the spring balance is used to measure the apparent weight  $W_2$  when both the cork and the sinker are submerged.

The following observations were made:

$$W = 0.08\text{N}$$

$$W_1 = 0.60\text{N}$$

$$W_2 = 0.28\text{N}$$

Use this information to determine the:

- Upthrust cork. (3 marks)
- Relative density of cork. (3 marks)



- b) Fig 14 shows parts of a simple submarine, a ship that can travel both on water and under water. To do this water is pumped in or out of the ballast tanks.

Fig 14

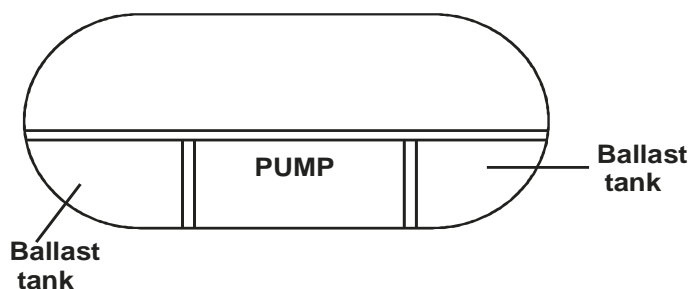

Explain how the tanks are used to change the depth of the submarine.

(2 marks)

### THARAKA SOUTH FORM FOUR JOINT EXAMINATION

Kenya Certificate of Secondary Education

232/2

PHYSICS

Paper 2

July/August 2015

#### SECTION A (25 marks)

Answer ALL questions in this paper

1. Explain why a plain sheet of paper and a plane mirror both reflect light yet only the plane mirror forms images while paper cannot form images. (2 marks)
2. A negatively charged polythene rod is placed on a pan of a balance. State and explain what happens to the balance reading if a positively charged glass rod is brought closer to the polythene rod. (2 marks)
3. The figure one below shows a metallic rod placed in a coil connected to battery terminals A and B.

Fig 1

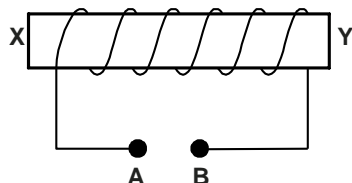

X is south pole and Y is north pole. Indicate the terminal of A and B on the diagram. (1 mark)

4. State the purpose of powdered manganese (IV) oxide mixed with carbon in a dry Leclanche cell. (1 mark)
5. An optical pin 20mm high is placed horizontally on the principal axis of a convex mirror of focal length 6cm as shown in the figure 2 below.

Fig 2

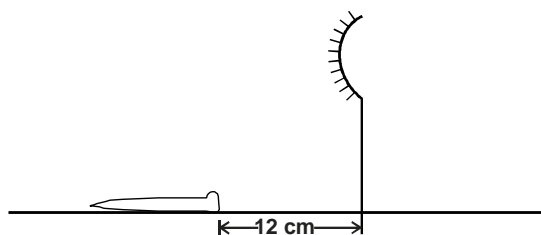

Determine the length of the image of the optical pin. (3 marks)

6. The period of a wave is T seconds. Its wavelength is  $\lambda$  metres. Show that  $v = f\lambda$ , where V is the speed of the wave and f is the frequency. (3 marks)
7. The figure 3 below shows wavefront in a ripple tank approaching a shallow region in the tank.

Fig 3

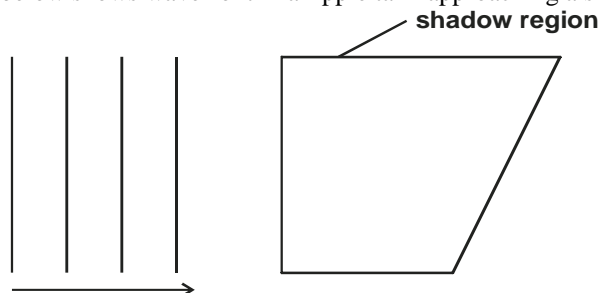

Complete the diagram to show the wavefront as they pass over shallow region and after leaving the region. (2 marks)

8. State two similarities of images formed by a plane mirror and a convex mirror. (2 marks)
9. State the reason why electrical power is transmitted over distances at very high voltages. (1 mark)

10. The figure 4 shows a horizontal conductor in a magnetic field parallel to the plane of the paper.

Fig 4

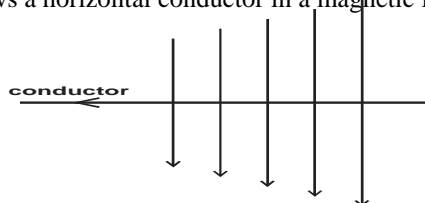

- State the directions in which the wire may be moved so that the induced current is shown by the arrow. (1 mark)
11. Define the term principal focus as applied in thin lenses. (1 mark)
12. QFM broadcasts at 96.4 MHz, determine the wavelength of the radio broadcast. (Speed of light,  $C=3.0 \times 10^8 \text{ m/s}$ ) (3 marks)
13. Define the term stopping potential as used in photo-electric effect. (1 mark)
14. The following reaction is part of reactive series.

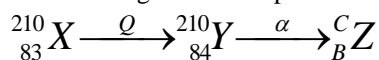

Identify the radiation Q and determine the values of B and C. (2 marks)

**SECTION B (55 marks)**

15. Define the refractive index of a substance. (1 mark)
- b) In an experiment to determine the refractive index in a liquid, the liquid was poured into a measuring cylinder. A pin was placed at the bottom of the cylinder and another pin was used to locate the apparent position of the first pin. The real and apparent depth were measured. The experiment was repeated with other values of real depth. The table below shows the results obtained.

Real depth (cm)	5	10	15	20	25
Apparent depth (cm)	3.3	6.7	10	13.3	16.7

- i) Plot the graph of real depth against apparent depth. (5 marks)
- ii) From the graph determine the refractive index of the liquid. (3 marks)

- c) The figure 5 shows a ray of light incident on a glass-air interface.

Fig 5

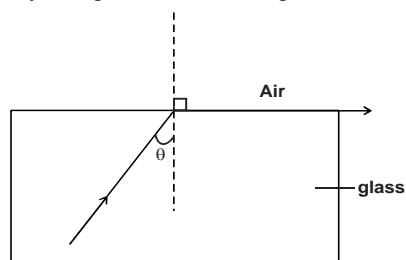

Given that the refractive index of the glass is 1.6, determine angle  $\theta$ .

- 16 a) State Ohm's law. (3 marks)
- b) Study the circuit diagram (Fig 6) below and answer the questions that follow. (1 mark)

Fig 6

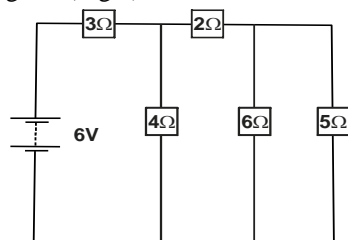

- i) Calculate the effective resistance of the circuit. (3 marks)
- ii) Find the total current in the circuit. (2 marks)
- c) The figure 7 below shows a low voltage lighting circuit.

Fig 7

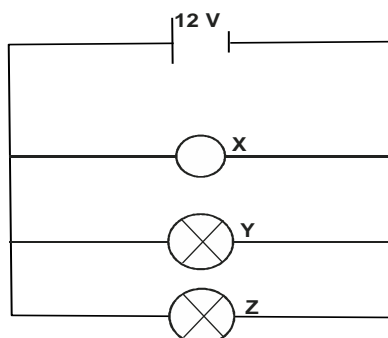

- i) On the figure indicate with letter S a point in the circuit where a switch could be placed that would turn off lamp Y and Z at the same time but would leave lamps X still lit. (1 mark)
- ii) The current in lamp Z is 3.0A, calculate the resistance of this lamp. (2 marks)
- d) The diagram 8 shows three capacitors connected to a power supply of 5V.

Fig 8

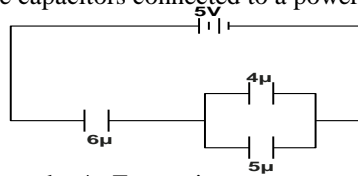

Determine the voltage across the 4mF capacitor. (3 marks)

17. a) The figure 9 below shows the features of an X-ray tube.

Fig 9

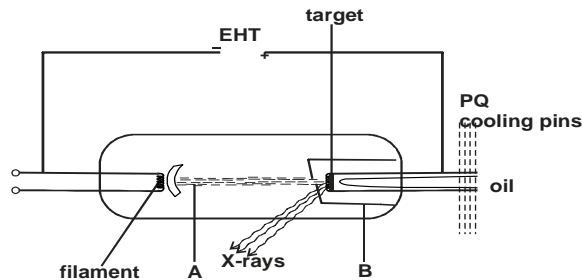

- i) Name the part labelled with letters A and B. (2 marks)
- ii) Explain how a change in the potential across PQ changes the intensity of x-rays. (2 marks)
- iii) During the operation of the tube, the target becomes very hot. Explain how this heat is caused. (2 marks)
- iv) State the property of lead that makes it suitable for use as shielding material. (1 mark)
- b) In a certain X-ray tube, the electrons are accelerated by a p.d. of 1200V. Assuming all the energy goes to produce X-rays, determine the frequency of the x-rays produced. (3 marks)
- (plank's constant  $h = 6.62 \times 10^{-34}$  JS, charge on an electron =  $1.6 \times 10^{-19}$ C)
18. a) The circuit below shows a lighting circuit for a house.

Fig 10

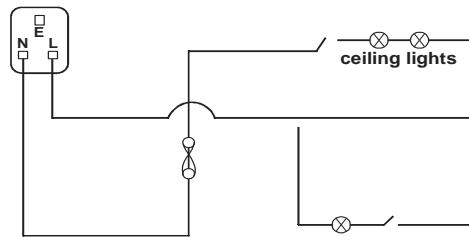

Mention any two mistakes in the wiring circuit. (2 marks)

- b) A house has four lamps rated (60W, 240V), a cooker rated (5kw, 240V), and an iron box rated (1kW, 240V). All are used 3.5 hours a day. Calculate the monthly cost for electricity for the owner at the rate of 13.5 cents/ KWhr. (3 marks)
- c) A bicycle dynamo is an example of an a.c. generator, state one way of increasing the brightness of the bulb. (1 mark)
- d) Figure 11 shows the loudspeakers L<sub>1</sub> and L<sub>2</sub> connected to a signal generator.

Fig. 11

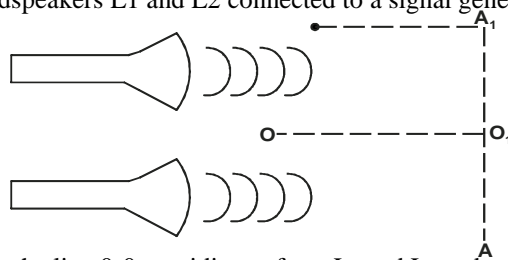

An observer walks along the line 0-0<sub>1</sub> equidistant from L<sub>1</sub> and L<sub>2</sub> and another along the line AA<sub>1</sub>

Explain the observation made by each and give reasons to your answers.

- i) Along A<sub>1</sub>OA (2 marks)
- ii) Along 0 - 0<sub>1</sub> (2 marks)
19. a) The table below shows how the activity of a radioactive nuclide varies with time.

Time in minutes	0	1	2	3	5	6	8	11
Count rate per minute	420	341	285	230	162	131	85	50
Activity per minute								

- i) Give that the background radiation count is 10 counts per minute complete the table. (2 marks)
- ii) Plot a graph of activity against time. (5 marks)
- iii) From the graph determine the half life of the sample. (1 mark)
- b) A radioactive element X of half-life of 28 days decay to element Y. A sample of X of mass 16g is kept in a container. Assuming Y is stable, determine the mass of Y that will be found in the containers after 112 days. (3 marks)



- e) i) On the grid provided plot the graph of  $V$ (y-axis) against  $L$ . (5 marks)  
 ii) From the graph, determine  $l_1$ , the value of  $l$  when  $V = \frac{V_0}{2}$  where  $V_0$  is the p.d. where  $L = 0$  (1 mark)
- f) Determine the constant  $D$  for the wire given that  $D = \frac{R}{l_1} \times \frac{300}{V_0}$  (2 marks)
- f) Determine the constant  $p$  given that  $p = \frac{\pi r^2}{2} (D + H)$ , where  $r$  is the radius of the wire in metres. (2 marks)

## 2. Part A

You are provided with

- A pendulum bob with a piece of thread
- Two wooden blocks
- Clamp, boss and retort stand.
- Metre rule
- Half metre rule attached to a wooden block
- Cellotape

- a) Fix the thread between the wooden blocks and fasten them in the clamp. Adjust the thread so that the length  $L$  shown in the figure below is 50cm. Fix the metre rule horizontally on the bench using the cellotape provided. Adjust the cellotape so that the bob is next to the end of the metre rule as below.

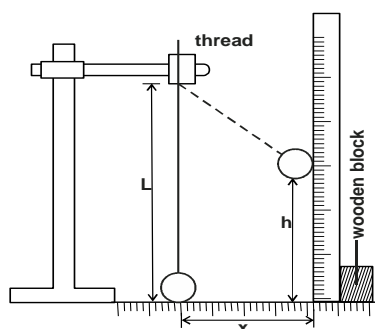

- i) Displace the bob by horizontal distance  $x = 20\text{cm}$  and measure the corresponding vertical displacement.  
 $h = \dots\dots\dots\text{cm}$
- ii) Repeat the experiment to find  $h$  for each of the values of  $x$  in the table below. Complete the table. (6 marks)

$x(\text{cm})$	$h(\text{cm})$	$x^2(\text{cm}^2)$	$\frac{x^2}{100}$ ( $\text{cm}^2$ )
20		400	
25		625	
30		900	
35		1225	
40		1600	
45		2025	

- iii) Plot the graph of  $\frac{x^2}{100}$  against  $h$ . (2 marks)
- iv) Determine the slope  $S$  of the graph. (2 marks)
- v) Determine the value of the constant  $K$  given that  $X^2 = 100sh + 100k$  where  $s$  is the slope. (2 marks)

## PART B

You are provided with the following apparatus.

- a convex lens
- a lens holder
- a screen
- a candle
- a metre rule

Set up the apparatus as below.

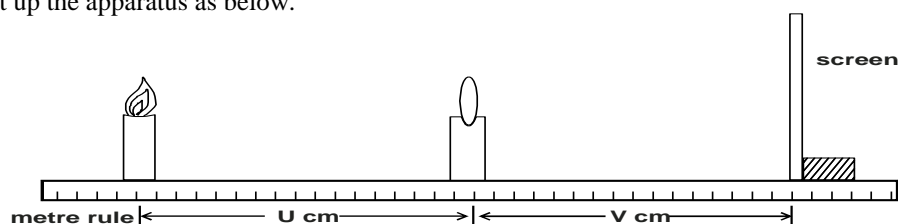

With  $U = 20\text{cm}$ , move the screen until a sharp image of candle is formed. Measure the distance  $V$  cm.

b) Repeat the above with  $U = 30$  and complete the table. (3 marks)

$U(\text{cm})$	20	30
$V(\text{cm})$		
$m = \frac{V}{U}$		

c) Hence calculate the focal length of the lens. (2 marks)

### THARAKA SOUTH JOINT EXAMINATION

Kenya Certificate of Secondary Education

#### PHYSICS

Paper - 232/1

July/August - 2015

#### MARKING SCHEME

1. Volume of 55 drops = 8ml ;

$$\text{Volume of one drop} = \frac{8}{55} = 0.15\text{ml or } 0.15\text{cm}^3$$

2.  $(2.53 + 0.50)\text{sec} = 3.03\text{ sec}$ ;

3. Air (molecules) are expelled by heating; Cooling creates partial vacuum, pressure inside is less than atmospheric pressure; it collapses

$$\begin{aligned} 4. \quad m &= \frac{w}{g}; \\ &= \frac{16.5}{1.7}; \\ &= 9.71\text{kg}; \end{aligned}$$

5. Flame heats air which becomes less dense / expands; and hence moves upwards; This will push the blades upwards / causes a convectional current; hence rotation 1

6. Flask which is in contact with the heat expands first; then the liquid expands more / faster than glass; 1

$$\begin{aligned} 7. \quad f_1 d_1 &= f_2 d_2; \\ 20 \times 1.0 &= d_2 \times 50 \\ d_2 &= \frac{20}{50} = 0.4\text{m} \end{aligned}$$

8.

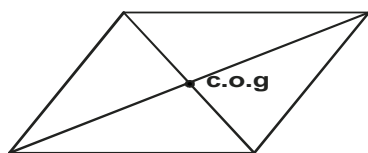

9. a) Air above the plane moves faster than air blow (due to its shape) creating a region of lower pressure above the plane hence lifting due to pressure difference;

b) At B; (narrowest part) because of C.S.A is smallest hence the air moves faster in that region;

10. a)  $(5.0 - 4.04) = 0.96\text{N}$ ;

b)

$$\begin{aligned} \frac{m}{v} &= p; \\ \frac{0.096}{v} &= 800; \\ v &= 120\text{cm}^3; \\ &= 1.2 \times 10^{-4} \text{m}^3 \end{aligned}$$

or

$$w = \rho v g, 0.96 = 80v \times 10$$

$$v = 120\text{cm}^3$$

11. Diffusion of ink molecules;  
 12. Mass is constant / fixed ;  
 13. Newton per metre; Deny N/m

**SECTION B**

14. a) i) OA; constant uniform acceleration;  
 ii) AB: decreasing / reducing acceleration;  
 iii) BC : constant velocity / zero acceleration;  
 b) i)  $v = u + at$ ;  
 $v = 10 - 2.5 \times 1.5 = 6.25\text{m/s}$ ;  
 ii)  $s = ut + \frac{1}{2} at$ ;  
 $= 10(1.5) - \frac{1}{2} \times 2.5 \times 1.5^2$   
 $= 12.1875 \approx 12.19\text{m}$ ;  
 iii)  $v = u + at$  ;  $0 = 10 - 2.5t$   
 $t = \frac{10}{2.5} = 4 \text{ sec}$ ;

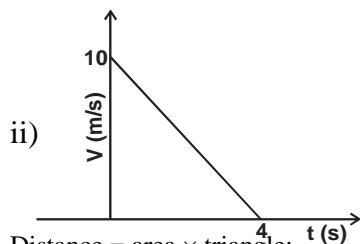

- ii) Distance = area  $\times$  triangle;  
 $= \frac{1}{2} \times 4 \times 10 = 10\text{m}$ ;

15. a)  $F = ma$ ;  
 $F = 2 \times 5 = 10 \text{ N}$ ;  
 $F_r = 12 - 10 = 2\text{N}$ ;  
 b) i) OA the ball bearing accelerates (at a reducing rate); viscous force increases to a maximum; or friction increases to a max.  
 ii) Ball attains terminal velocity / constant velocity;  
 Resultant force = zero;  
 $w = u + Fr$   
 c) i) 2;  
 ii) To change the direction of effort  
 iii)

$$Eff = \frac{M.A.}{V.R.} \times 100$$

$$80 = \frac{M.A.}{2} \times 100,$$

$$80 = \frac{l}{2 \times 500} \times 100$$

$$M.A = \frac{L}{E}$$

$$L = \frac{80 \times 1000}{100}$$

$$= 800\text{N}$$

16. a) i)  $Q = pt$ ;  
 $= 2.5 \times 10^3 \times 4 \times 60 = 600,000 \text{ J}$   
 ii)  $Q = MC\Delta\theta$

$$\Delta\theta = \frac{Q}{MC} = \frac{600,000}{2 \times 4.2 \times 10^3}$$

$$= 71.43^\circ\text{C}$$

- b) i)  $p = 76\text{cm Hg}$ ;  
 ii) I.  $P = (24 + 76) = 100\text{cmHg}$ ;  
 II.  $P_1V_1 = P_2V_2$ ;  
 $76 \times 15 = (76 + 24) L$ ;

$$L = \frac{76 \times 15}{100} = 11.4\text{cm};$$

17. a) Increasing angular velocity; reducing radius of path;  
 b) i) Tension in the string

- ii) Towards centre of circle  
 iii) Direction of speed of object changes (and causes velocity to change)

$$\begin{aligned} \text{iv) } F &= \frac{MV^2}{r} && ; \\ &= \frac{0.5 \times 8^2}{2} && ; \\ &= 16N; && ; \end{aligned}$$

I.  $F = Ke;$

$$F = \frac{25N}{M} \times 0.03$$

II.  $F = ma;$   
 $= 0.75N;$

$$\begin{aligned} 0.75 &= 2a; \\ a &= 0.375\text{ms}^{-2} \end{aligned}$$

- III. Force in spring decreases as spring recovers original length  
 No force on the trolley after contact with wall is lost 1

18. a) i)  $W_1 - W_2; \quad (W_1 - W) - (W_2 - W)$   
 $= 0.60 - 0.28 \quad (0.28 - 0.08) - (0.6 - 0.08)$   
 $= 0.32N \quad = 0.52 - 0.2$   
 $= 0.32 \quad = 0.32$

ii)  $Upthrust = \frac{\text{weight of substance}}{\text{weight of equal volume of water}}$

$$\begin{aligned} &= \frac{0.08}{0.32}; \\ &= 0.25; \end{aligned}$$

- b) To sink water is allowed into tanks; 1  
 To float, pumps are used to expel water from the ballast tanks;

### THARAKA SOUTH JOINT EXAMINATION

Kenya Certificate of Secondary Education

#### PHYSICS

Paper - 232/2

July/August - 2015

#### MARKING SCHEME

1. Image formation takes place with regular ✓1 reflection on plane mirror not with diffuse / irregular ✓1 reflection on sheet of paper. **2mks**

2. The balance reading decreases ✓1

This is due to force of attraction ✓1 between the oppositely charged rods. **2 marks**

3. A(-) B(+) ✓1 **1 mark**

4. Acts as a depolarizer. **1 mark**

5.

$$\begin{aligned} \frac{1}{f} &= \frac{1}{u} + \frac{1}{v} && - \frac{1}{6} = \frac{1}{14} + \frac{1}{v} \\ -\frac{1}{6} &= \frac{1}{12} + \frac{1}{v} && -\frac{1}{6} - \frac{1}{12} = \frac{1}{v} \\ \frac{1}{v} &= \frac{-2-1}{12} = \frac{-3}{12} && \frac{-7-3}{42} = \frac{-10}{42} \\ v &= -4cm && v = -4.2cm \end{aligned}$$

Image length =  $4.2 - 4 = 0.2\text{cm}$  ✓1 **3 marks**

6. Speed  $V = \frac{\text{Distance}}{\text{time}} = \frac{\lambda}{T}$

but  $T = \frac{\lambda}{f} = \lambda F$



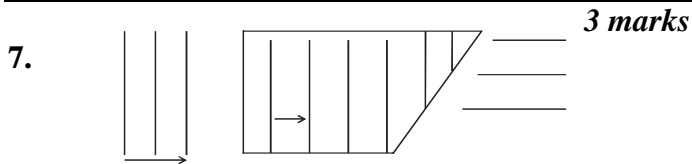

Check change in wavelength = **2 marks**

8. Upright / erect  
Behind the mirror  
Virtual. **any two - 2 marks**
9. High voltage leads to low current hence low power losses or low energy  $\checkmark$  losses, Deny heat losses. **1 mark**
10. Motion into the paper  $\checkmark$  or  
motion downward. **1 mark**
11. A point on the principal axis where light rays close and parallel to the principal axis converge or appear to diverge from after refraction by the lenses. **1 mark**
12.  $C = \lambda F$

$$\lambda = \frac{3 \times 10^8}{96.4 \times 10^6}$$

$$\lambda = 3.112M$$

13. It is the voltage required to completely stop the most energetic electrons from reaching the anode.  
OR  
It is negative potential sufficient to just stop the ejection of the electron. **1 mark**

14. Q is beta ( $\beta$ )  $\checkmark$   
B = 82  
C = 206  $\checkmark$

**Section B (55 marks)**

15. a) This is the ratio of sine of the angle of incidence to the sine of the angle of refraction.  
OR

$$n = \frac{\sin i}{\sin r}$$

b)

ii)

$$M = \frac{\Delta y}{\Delta x}$$

$$= \frac{15 - 6}{10 - 4} = \frac{9}{6}$$

$$= 1.5 \pm 0.1$$

3 marks

c)

$$n = \frac{1}{\sin \theta} \quad 1.6 = \frac{1}{\sin \theta}$$

$$1.6 \sin \theta = 1$$

$$\sin \theta = \frac{1}{1.6} = 0.625$$

$$\sin^{-1} = 0.625 = 38.68\%$$

16. a) current through conductor is directly proportional to the applied voltage provided temperature and other physical conditions are kept constant.

b) i) Parallel resistance =  $\frac{6 \times 5}{6 + 5} = 2.73 \Omega$

Parallel resistance =  $\frac{4 \times 2}{4 + 2} = 1.33 \Omega$

Series resistance = 3.00  $\Omega$   
Effective resistance  
= 2.73 + 1.33 + 3.00  
= 7.06  $\Omega$   $\checkmark$  **3 marks**

$$I = \frac{V}{R} = \frac{6}{7.06} = 0.84 A$$

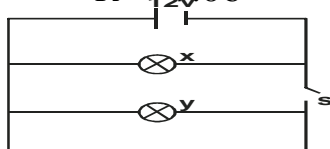

c) i)

$$\begin{aligned} \text{ii)} \quad R &= \frac{V}{I} \\ &= \frac{12}{3} = 4\Omega \\ M &= \frac{\Delta y}{\Delta x} \\ &= \frac{15 - 6}{10 - 4} = \frac{9}{6} \\ \text{d)} \quad &= 1.5 \pm 0.1 \end{aligned}$$

$$\left( \frac{6 \times 9}{6. + 9} \right) \times 5 = 18 \mu\text{C}$$

$$V(\text{across } 4/6) = \frac{Q_T}{C} = \frac{18 \mu\text{C}}{6 \mu\text{F}} = 3V$$

$$\begin{aligned} V_T &= V_1 - V_2 \\ &= 5 - 3 = 2V \end{aligned}$$

17. a) i) A - electron beam ✓  
 B - Anode ✓ 2 marks
- ii) Charge in p.d. across PQ changes filament current. ✓  
 This changes the number of electrons released by cathode hence intensity of the x-rays changes. ✓  
 Increase in p.d. increase the intensity and vice versa. ✓ 2 marks
- iii) Most of the kinetic energy ✓ of electrons hitting target is converted into heat. ✓ 2 marks
- iv) High density ✓

b)  $E = hf$   
 $1.6 \times 10^{-19} \times 12000 = 6.62 \times 10^{-34} \times f$   
 $f = \frac{1.6 \times 10^{-19} \times 12000}{6.62 \times 10^{-34}}$   
 $= 2.9 \times 10^{18} \text{ Hz}$

3 marks

- 18.a) - lamps should be connected in parallel and not in series connection. ✓  
 The fuse should be connected to the like wire and not to the neutral. ✓ 2 marks
- b) Number of units =  $0.306 + 5.0 + 1.0 = 6.06$  units ✓  
 Total units =  $(6.06 \times 3.5 \times 30) = 636.3$  units ✓  
 Total cost =  $636.3 \times 13.5 = 85.90$  shillings ✓ 3 marks
- c) Cycling faster. ✓
- d) i) Loud and soft sound heard is due to constructive and destructive interferences. ✓  
 At one point waves arrive in phase while in the other arrive out of phase. ✓ 2 marks
- ii) Loud sound heard is due to ✓ constructive interference because waves arrive in phase. ✓ 2 marks

19. a)  
i)

Activity per minute	410	331	275	220	152	121	75	40
---------------------	-----	-----	-----	-----	-----	-----	----	----

- All values correct award 2 marks
  - Half values correct or more than half values correct award 1 mark
  - Less than half values correct award zero.
- iii)  $3.4 \text{ min} \pm 0.1$  ✓

b)  $M = M_o \left( \frac{1}{2} \right)^{t/t_{1/2}}$   
 $= 16 \left( \frac{1}{2} \right)^{\frac{112}{28}}$   
 $= 16 \left( \frac{1}{2} \right)^4 = 16 \times \frac{1}{16} = 1g$   
 Mass of Y =  $16 - 1 = 15g$

**THARAKA SOUTH JOINT EXAMINATION**

Kenya Certificate of Secondary Education

**PHYSICS**

Paper - 232/3

July/August - 2015

**MARKING SCHEME**

1. a)  $L_o = 100\text{cm} / 1\text{m}$   
 $d_1 = 0.26\text{mm}, d_2 = 0.26\text{mm};$

$$d = \frac{0.26 + 0.26}{2}$$

$$= 0.26\text{mm};$$

$$\text{Radius} = \frac{d}{2} = \frac{0.26 \times 10^{-3}}{2}$$

$$= 0.00013\text{m}$$

- b) i)  $V_R = 2.1\text{ volts};$   
 $V_a = 2.41\text{ volts};$

$$\text{ii) } I = \frac{V}{R} = \frac{2.1}{3.9} = 0.54\text{A};$$

$$\text{iii) } H = \frac{100V_o}{1 \times L_o} = \frac{100 \times 2.4}{0.54 \times 1} = 444.4\text{nm}^{-1}$$

d)

Distance L (cm)	0	2	10	20	30	40	50	70
p.d. V across RV	2.1	1.6	1.3	1.0	0.8	0.7	0.5	0.4

- e) ii)  $L_1 = 15\text{cm} = 0.15\text{m};$  1

$$\text{f) } D = \frac{3.9 \times 300}{0.15 \times 2.1}$$

$$= 3714.3\Omega\text{m}^{-1}\text{V}^{-1}$$

$$\text{g) } \rho = \frac{\pi r^2}{2}(D + H)$$

$$= \frac{3.14 \times (0.00013)^2}{2}(3714.3 + 444.4)$$

$$= 0.00011$$

$$= 1.1 \times 10^4$$

**2 Part A**

- i)  $h = 5\text{cm}$

ii)

h(cm)	$\frac{x^2}{100}$
$5 \leq h \leq 7$	4.00
$7 \leq h \leq 9$	6.25
$10 \leq h \leq 13$	9.00
$15 \leq h \leq 17$	12.25
$20 \leq h \leq 22$	16.00
$27 \leq h \leq 29$	20.25

$$\text{iv) } S = \frac{\Delta y}{\Delta x} = \frac{20.5 - 9}{27 - 10} = \frac{11.5}{17}$$

$$= 0.676\text{cm} \pm 0.1$$

$$\text{v) } X^2 = 100\text{shs} + 100\text{k}$$

$$\frac{x}{100} = Shs + k$$

100

k = y - intercept

extrapolation ✓1

2.50 cm ✓1

2 marks

**PART B**

b)

U(cm)	20	30
V(cm)	20	15
m =	1	0.5

2 marks

c)  $f_1 = \frac{20}{2} = 10$

$f_1 = \frac{30}{3} = 10$

$f = \frac{f_1 + f_2}{2} = \frac{10 + 10}{2} = 10\text{cm}$

**NYERI COUNTY FORM FOUR JOINT ASSESSMENT**

Kenya Certificate of Secondary Education

232/1

**PHYSICS**

Paper 1

July/August 2015

Time 2 hours

**SECTION A (25 marks)**

Answer ALL the questions in the spaces provided.

- Some water was put in a burette so that the level read 35.6cm<sup>3</sup>. 50 drops were then allowed to fall from the burette. The average volume of one drop was 0.14cm<sup>3</sup>. What is the new reading of the burette? (2 marks)
- Explain why water curves in a test as shown in the figure 1 below. (1 mark)

Fig 1

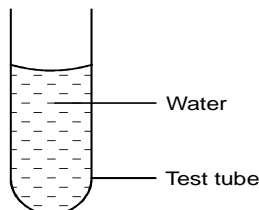

- Figure 2 below represents a system in equilibrium

Fig 2

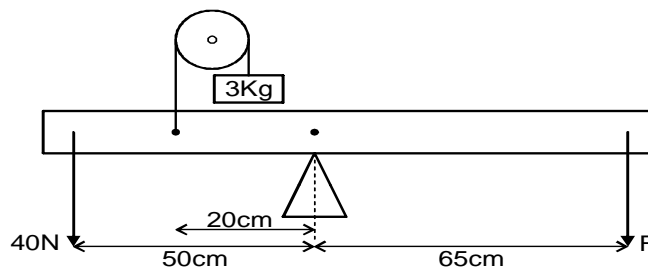

- Determine the force F needed to maintain the equilibrium. (3 marks)
- The figure 3 below shows a beaker containing molten candle wax. Indicate on the same diagram the position of the centre of gravity. When the candle wax solidifies.

Fig 3

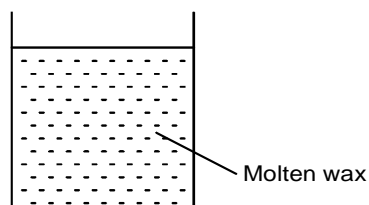

5. Figure 4 below shows a U tube manometer containing two liquids. Given that  $h_1$  and  $h_2$  are 22cm and 19cm respectively, find the density of the liquid Z. Give your answer to 2 significant figures. (3 marks)

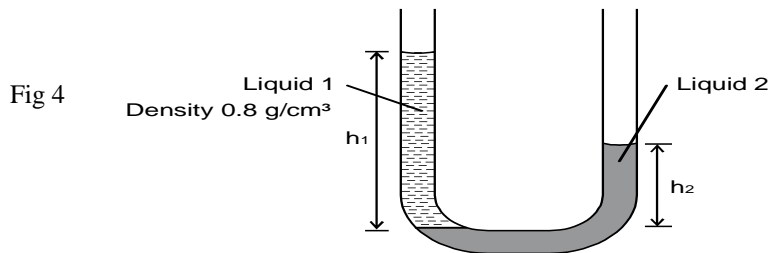

6. Explain why the rate of diffusion of a gas decreases with decrease in temperature. (1 mark)
7. State the reason why steel is normally used to reinforce concrete in construction other than aluminium (1 mark)
8. Figure 5 below shows a thick copper plate that is very hot, one side is black and the other is shiny. Two thermometers are placed at the same distance from each side as shown.

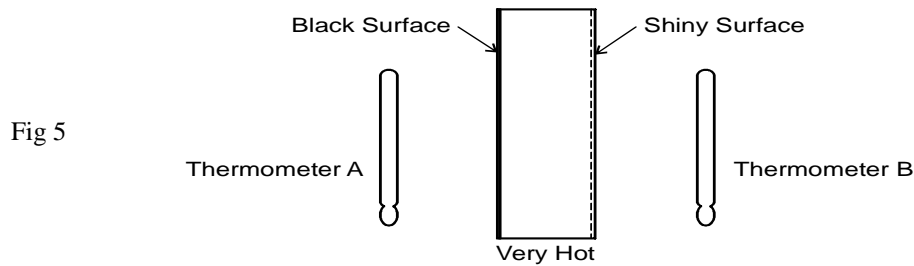

Neglecting heat loss to the surrounding, state with a reason which thermometer records a higher temperature after 10 minutes.

(2 marks)

9. The work done in stretching a spring by 50mm is given as 0.08J. Calculate the spring constant. (3 marks)
10. Figure 6 below shows an inverted funnel placed above a light ball.

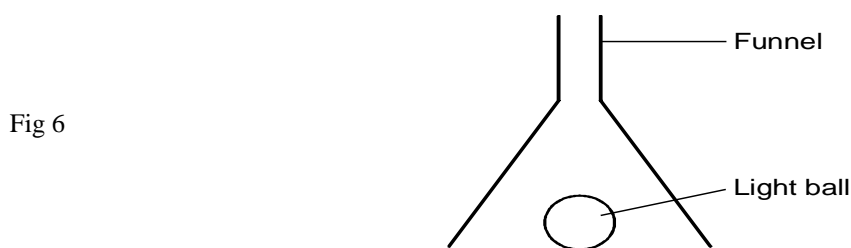

Fast moving air is then blown through the neck of the funnel. State and explain the observation made. (2 marks)

11. Figure 7(a) below shows a loop of a wire with a string tied loosely at point A and B. When the loop was dipped into a soap solution and then moved out a soap film is formed as shown. In fig 7(b) below. State and hence explain the observation made when side X of the film is broken. (2 marks)

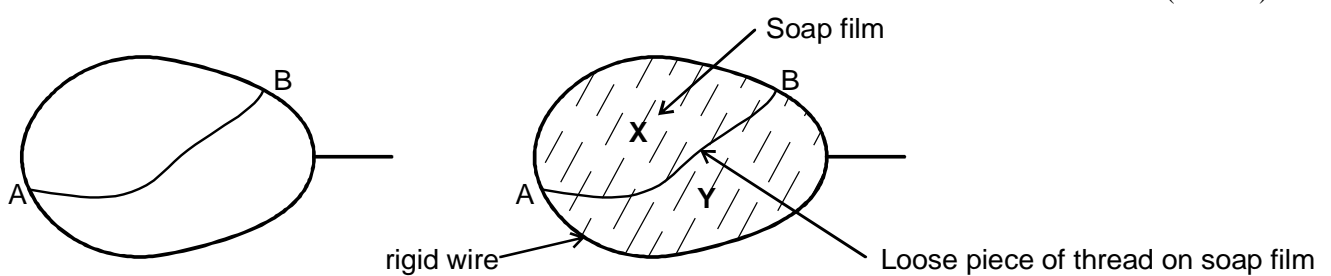
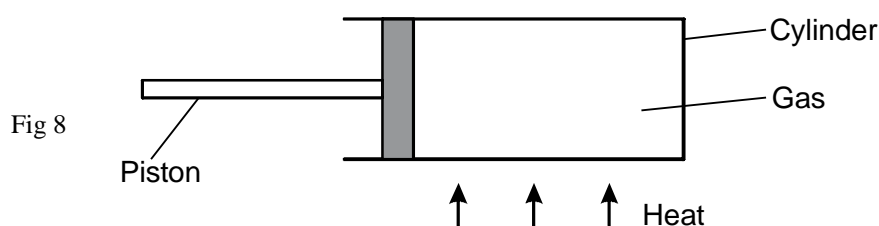

Fig 7 (a)

Fig 7 (b)

12. Differentiate between displacement and distance. (1 mark)
13. Figure 8 below shows a gas enclosed in a container.



State and explain using the kinetic theory of matter. What will happen to the piston when the cylinder is heated. (2 marks)

14. Figure 9 below shows block A placed on a bench connected with a piece of thread through a pulley to a pan B where masses are being added.

Fig 9

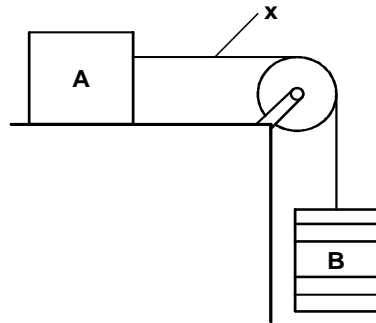

State a condition that must be met for block A to slide towards the right. (1 mark)

**SECTION B (55 marks)**

15. a) Differentiate between speed and velocity. (1 mark)  
 b) Figure 10 below shows velocity time graphs for two objects A and B drawn on the same axes.

Fig 10

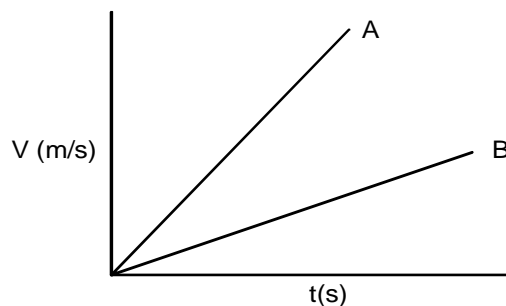

State with a reason which of the two objects stops in a shorter distance when the same size of force is applied against each given that they are of equal masses. (2 marks)

- c) An object moving at 26m/s starts to accelerate at  $2\text{m/s}^2$  so that its velocity becomes 48m/s. Find  
 i) The distance moved during this acceleration. (3 marks)  
 ii) The object is now braked so that it comes to rest in a time of 12 seconds. Find the braking force if its mass was 27000g. (3 marks)
16. a) Figure (11) below shows a pulley system used to lift a load.

Fig 11

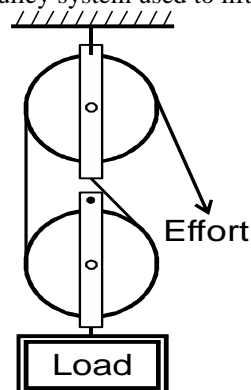

Determine the velocity ratio. (1 mark)

- b) The figure (12) below shows a loading ramp of length 8m and height 2m. Bags weighing 1000N each are conveyed from point O to P along the plane. Each bag experiences a friction force of 50N.

Fig 12

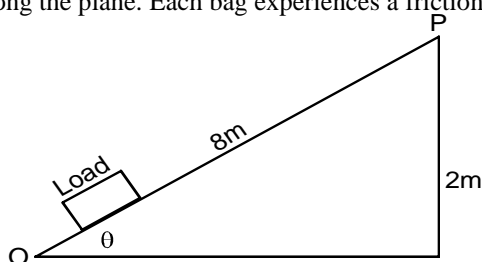

Show that the velocity ratio is given by  $1/\sin \theta$  (3 marks)

- c) State how you can increase for the arrangement
- Velocity ratio (1 mark)
  - Mechanical advantage (1 mark)
- d) i) The total work done by the effort on each bag. (3 marks)  
 ii) The efficiency of this system. (2 marks)
17. a) Define specific heat capacity. (1 mark)
- b) To determine the specific heat capacity of a solid by the method of mixtures, a solid of known mass was heated in blust furnace to very high temperature then quickly transferred to a liquid in a well lagged calorimeter.
- Give a reason why the solid was quickly transferred. (1 mark)
  - List two possible sources of error in this experiment. (2 marks)
- c) 50g of a metal was heated in a blust furnace to a temperature of 600°C. The metal was then quickly transferred to a copper calorimeter of mass 40g containing 20g of water at 70°C. It was observed that 5g of water vapourised. Given that the specific heats capacity of water and copper are 4200J/kgk, 390J/kgk respectively and specific latent heat of vaporization in 2260000 J/kg
- Find
- An expression for the heat lost by the metal given that its specific heat capacity in  $C_m$  (2 marks)
  - The heat gained by water and calorimeter. (3 marks)
  - The specific heat capacity of the metal. (3 marks)
18. a) State Archimedes principle. (1 mark)
- b) Figure 13 below shows a test tube floating in water in a tall beaker.

Fig 13

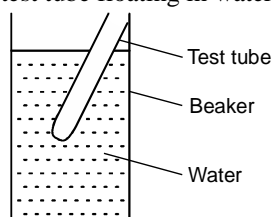

- State what can be done to make the text tube floating vertically upright. (1 mark)
  - Explain how the test tube may be calibrated to measure relative densities of liquids. (2 marks)
  - State what can be done to increase the sensitivity of such an instrument. (1 mark)
- c) Figure 14 below shows a block of dimensions 2cm × 4cm × 12cm floating in a liquid of density 1250kg/m<sup>3</sup>

Fig 14

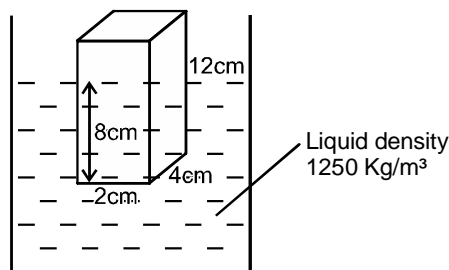

Find

- The upthrust on the block. (3 marks)
  - The weight of the block. (1 mark)
  - The force needed to just submerge the block completely. (3 marks)
19. a) Define angular velocity. (1 mark)
- b) Figure 15 below shows a small mass being rotated in a horizontal circle through a plastic tube. It is observed that as the small moves is rotated at constant speed, the heavy mass remains at the same horizontal level.

Fig 15

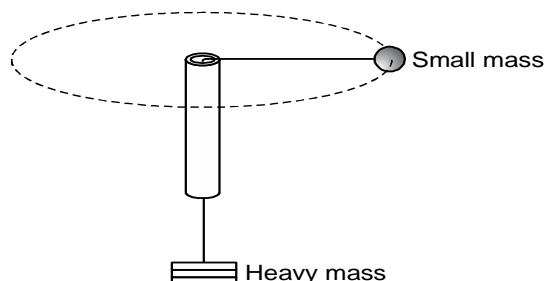

- State one adjustment that can be done to make the heavy mass move upwards. (1 mark)
  - State the effect on the small mass if a heavier mass was used in place of the one above and the radius of rotation remains constants. (1 mark)
- c) A stone of mass 200g tied to a long string 1m long and whirled round in a vertical circle at an angular speed of 6.28 rad/s.
- Why is the stone said to be accelerating. (1 mark)
  - Determine the linear velocity. (2 marks)
  - Its periodic time. (2 marks)
  - The critical speed of the stone if it is to describe a vertical circle. (2 marks)
- d) State a factor that determines the angle at which a road should be banked at a bend. (1 mark)

**NYERI COUNTY FORM FOUR JOINT ASSESSMENT**
*Kenya Certificate of Secondary Education*
**232/2**
**PHYSICS**
**Paper 2**
**July/August 2015**
**SECTION A (25 marks)**

Answer ALL questions in this section in the spaces provided.

1. A ray of light is incident on a plane mirror as shown in figure 1 below.

Fig 1

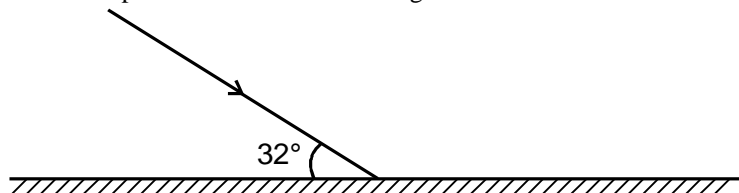

Determine the angle of reflection. (2 marks)

2. Plane water waves produced in a ripple tank are passed from a region of deep water into a region of shallow water. Figure 2 below shows the top view of the tank.

Fig 2

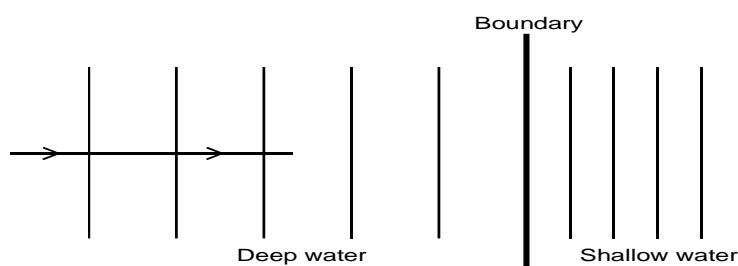

- State what happens at the boundary to the frequency of the waves. (1 mark)
  - The waves have a speed of 24cm/s in the deep water. Consecutive waves crests are 0.08m apart in the deep water. Calculate the frequency of the source producing the wave. (2 marks)
3. Explain how an increase in temperature affects the speed of sound in air. (1 mark)
4. Figure 3 below represents an object O and its image I after reflection by a convex mirror. On the same diagram locate by construction the principal focus F of the mirror. (2 marks)

Fig 3

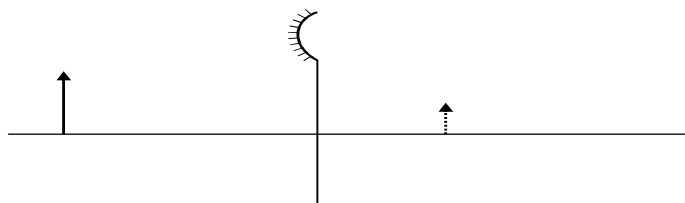

5. A boy scout standing a distance  $x$  from a tall building blows a whistle and hears its echo 1.7 seconds later. Determine the distance  $X$  between the boy and the wall given that the speed of sound in air is 340m/s. (2 marks)
6. A positively charged material was brought close to an insulated metallic object as shown in figure 4 below. Show the distribution of charge in the object. (2 marks)

Fig 4

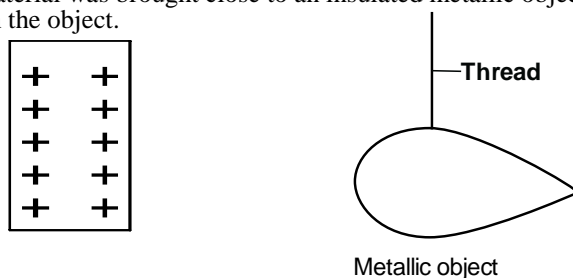

7. A student was investigating the brightness of bulbs when set up in different circuits. He used identical bulbs and cells. He set up circuits A and B as shown in figure 5(A) and 5(B) below.

Fig 5

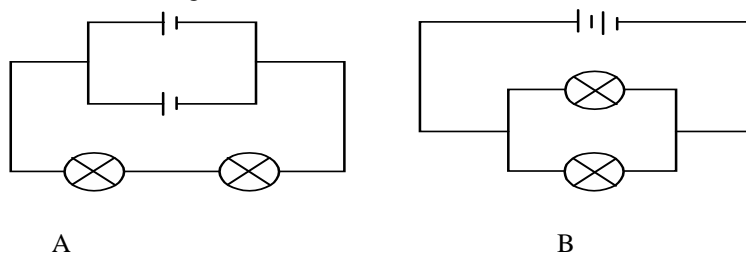



State and explain which set up had the bulbs light brightest.

(3 marks)

8. Figure 6 below shows a cell of Emf  $E$  volts and internal resistance  $r$  ohms. Connected to an external resistor  $R$ . If the current flowing is  $0.5A$ , find an expression for the internal resistance  $r$ . (2 marks)

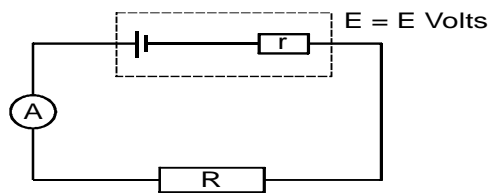

Fig 6

9. A wire of resistance  $20\Omega$  is connected to a battery of  $12V$ . Determine the heat dissipated in the wire in one minute. (3 marks)

10. State one way of increasing the magnitude of the induced Emf in a simple a.c. generator. (1 mark)

11. Figure 7 below shows a ring main circuit used by an electrician in a certain house.

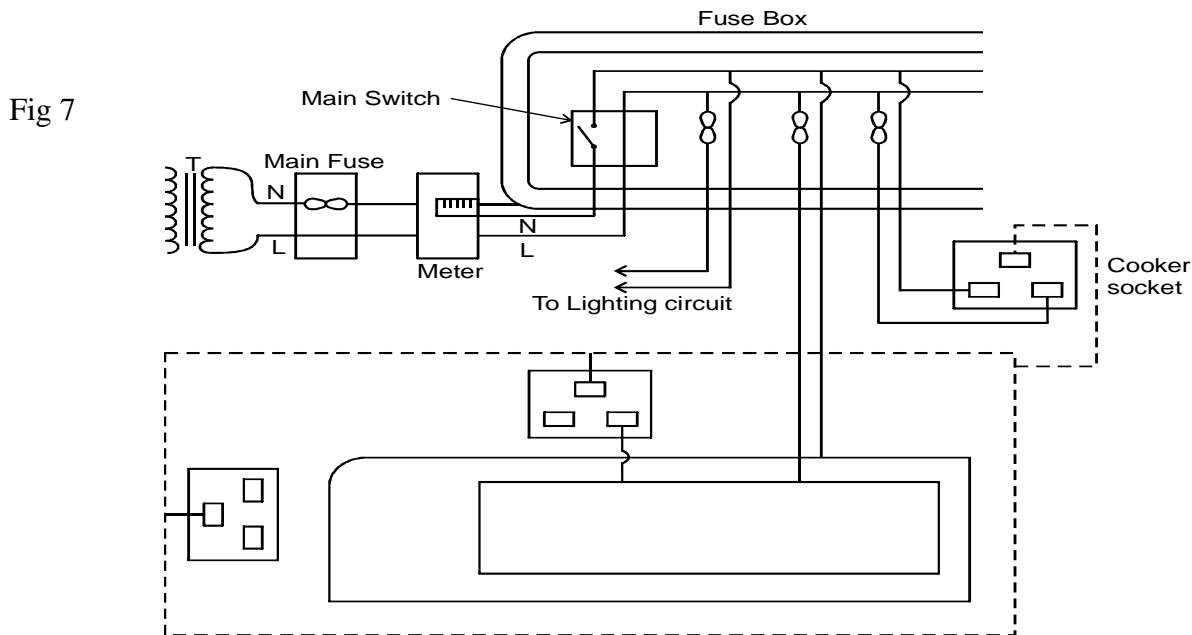

Fig 7

Identify two faults in the installation. (2 marks)

12. A plastic ring is placed between two poles of a magnet as shown in figure 8 below. Show the magnetic lines of force between the two poles. (1 mark)

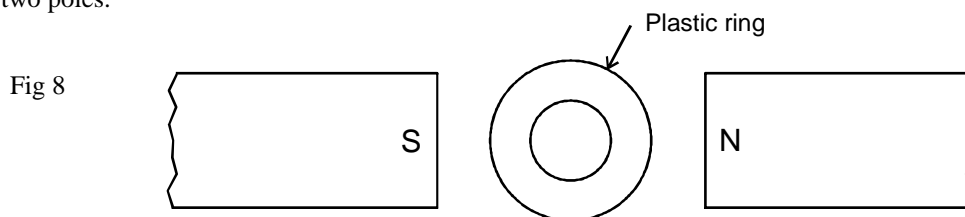
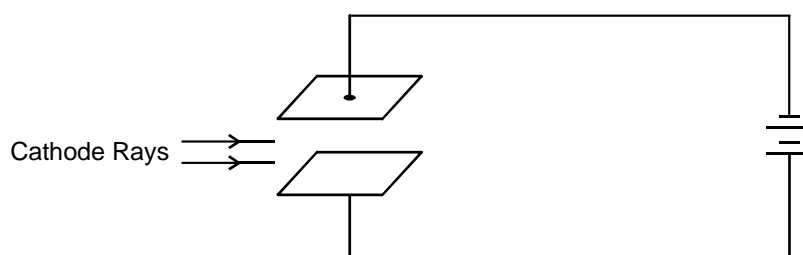

Fig 8

13. Cathode rays are incident between two plates as shown in figure 9 below. Complete the diagram to show the path followed by the cathode rays as they pass through the plates. (1 mark)

Fig 9



**SECTION B (55 marks)**

Answer ALL questions in this section in the spaces provided.

14. a) Two coins were placed at the bottom of two jars each containing a different clear liquid as shown in figure 10 below.

Fig 10

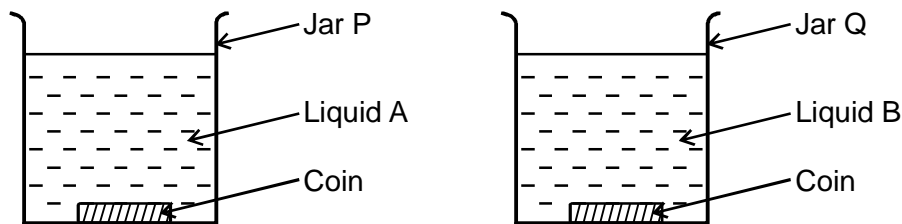

The liquids in the two jars are at the same level. The coin in jar q appears shallower than that in jar P. Explain.

(1 mark)

- b) A ray of light travels from air to glass as shown in fig 11 below.

Fig 11

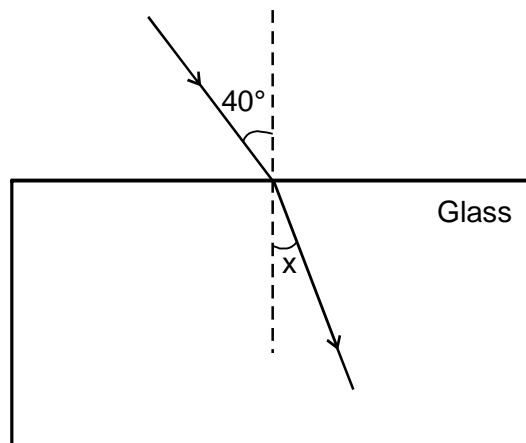

Given that the critical angle of glass is  $42^\circ$ . Determine the value of angle x.

(4 marks)

- c) Figure 12 below shows a ray of light incident on a triangular prism and a white screen is placed in front of the prism.

Fig 12

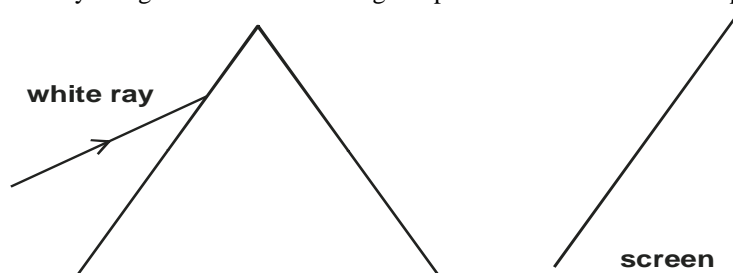

Complete the diagram to show the path followed by the ray upto the screen.

(2 marks)

- d) Figure 13 shows a glass lens in air and its two focal points  $F_1$  and  $F_2$ .

Fig 13

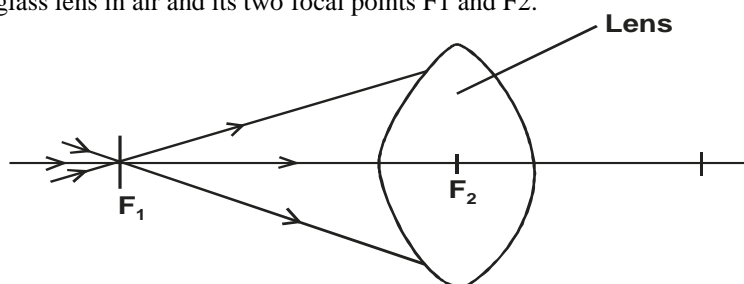

Three rays of light pass through  $F_1$  to the lens, on the figure show the path followed by the three rays through the lens and into the air.

(1 mark)

- i) State one possible cause of myopia.

(1 mark)

- ii) State the type of lens that is used to correct myopia.

(1 mark)

- e) In an experiment to determine the focal length of a converging lens several values of image distance and the corresponding magnification were obtained. A graph of magnification  $m$  against image distance ( $V$ ) was plotted as shown below.

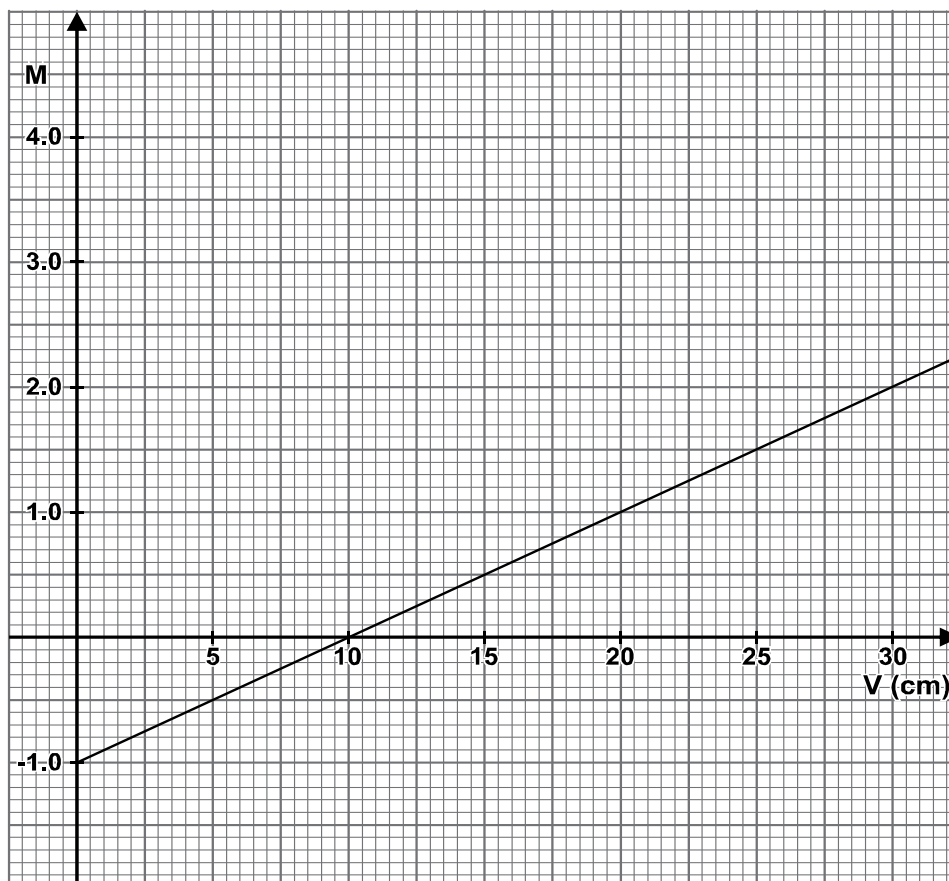

- From the graph determine the focal length of the converging lens. (3 marks)
15. a) In figure 15 shown below. Two identical electroscopes A and B carry the same type of charges as shown. The two are then connected with a copper wire.

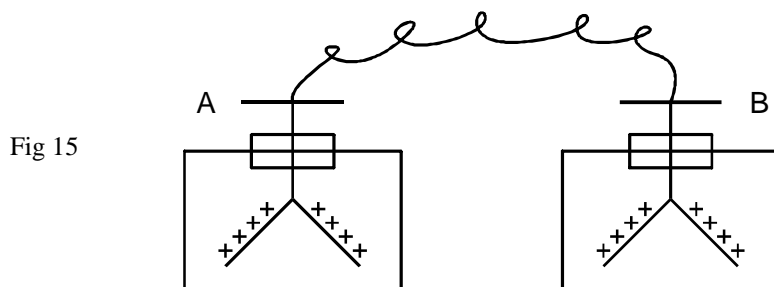

- State and explain the observations made. (2 marks)
- b) When a charged body P is brought close to the cap of a negatively charged electroscope the leaf of the electroscopes rises. State with reason the charge on the body P. (2 marks)
- c) Four capacitors were connected in a circuit as shown in figure 16 below. Determine the charge stored in the combination of the capacitors when the switch is closed. (4 marks)

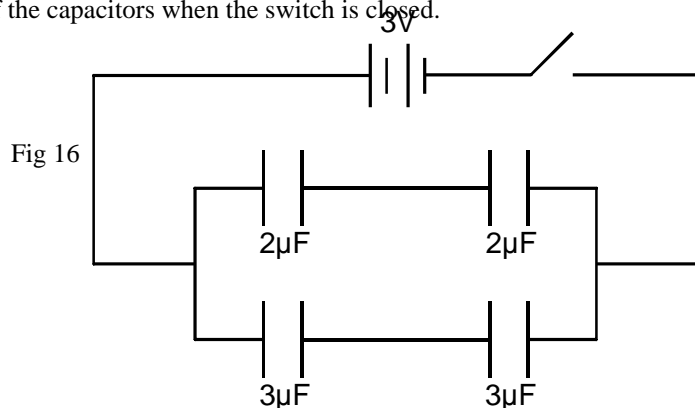

- d) State two ways in the capacitance of a parallel plate capacitor can be increased. (2 marks)

16. a) Figure 17 below shows a simplified illustration of an x-ray tube.

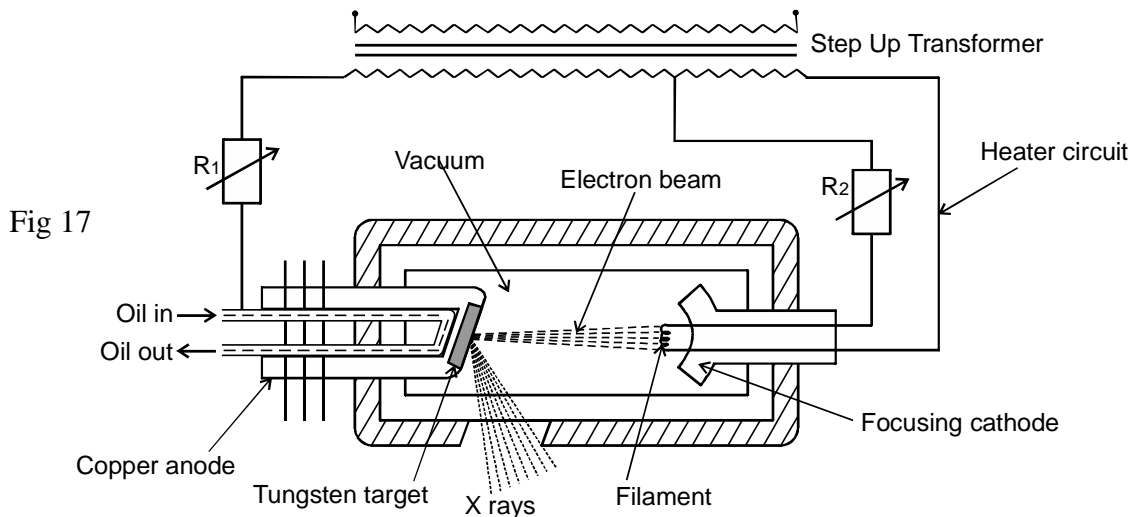

- Explain the functions of  $R_1$  and  $R_2$  (2 mark)
- b) An x-ray tube has an electron beam current of 10mA and its accelerating voltage is 50KV.  
 The efficiency of the x-ray tube 0.5%  
 Planks constants  $h = 6.63 \times 10^{-34}$  Js  
 Charge on an electron  $e = 1.6 \times 10^{-19}$ C  
 Velocity of light  $C = 3 \times 10^8$ m/s  
 Determine
- the number of electrons hitting the target per second. (2 marks)
  - the power input. (2 marks)
  - the power lost in the tube in form of heat. (2 marks)
  - The minimum wavelength of the x-rays produced. (3 marks)
17. a) What is meant by the term 'work function' of a metal surface. (1 mark)
- b) Figure 18 below shows a set up used to observe photoelectric effect.

Fig 18

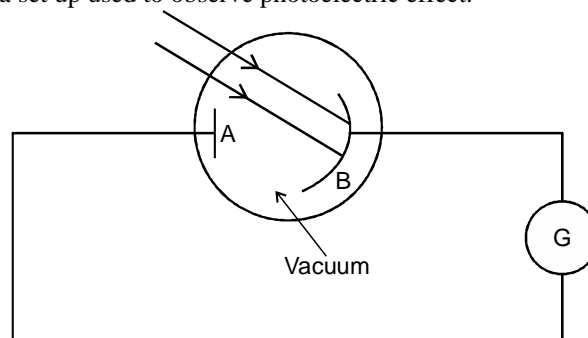

- State two factors that determine whether photoelectric effect will occur or not when the radiation strikes the metal surface B. (2 marks)
  - State one way in which the reading on the galvanometer can be increased. (1 mark)
- c) The work function of potassium is 2.0 eV. A pattern surface is illuminated with a radiation of frequency  $8.0 \times 10^{14}$  HZ.  
 Determine
- the energy of the incident radiation. (2 marks)  
 (given the  $h = 6.63 \times 10^{-34}$  Js  $e = 1.6 \times 10^{-19}$ C)
  - The maximum kinetic energy of the emitted photoelectrons. (3 marks)
18. a) In terms of energy band theory state the difference conductors and semiconductors. (2 marks)
- b) Figure 19 below shows an electric circuit.

Fig 19

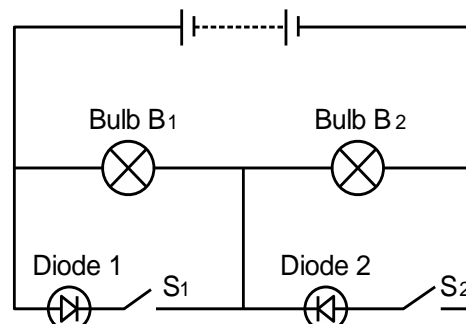

Explain what happens when only S2 is closed.

(2 marks)

c) The following equation shows part of a radioactive decay process.

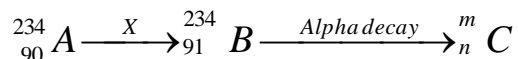

i) Name the radiation X.

(1 mark)

ii) Find the values of m and n.

(2 marks)

d) Figure 20 shows the three nuclear radiations labelled A, B and C under the influence of magnetic into the paper.

Fig 20

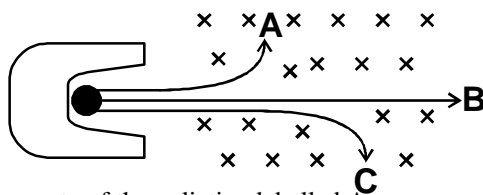

i) State one property of the radiation labelled A

(1 mark)

ii) State one use of the radiation B

(1 mark)

e) The graph below shows how the activity of a radiation nuclide varies with time.

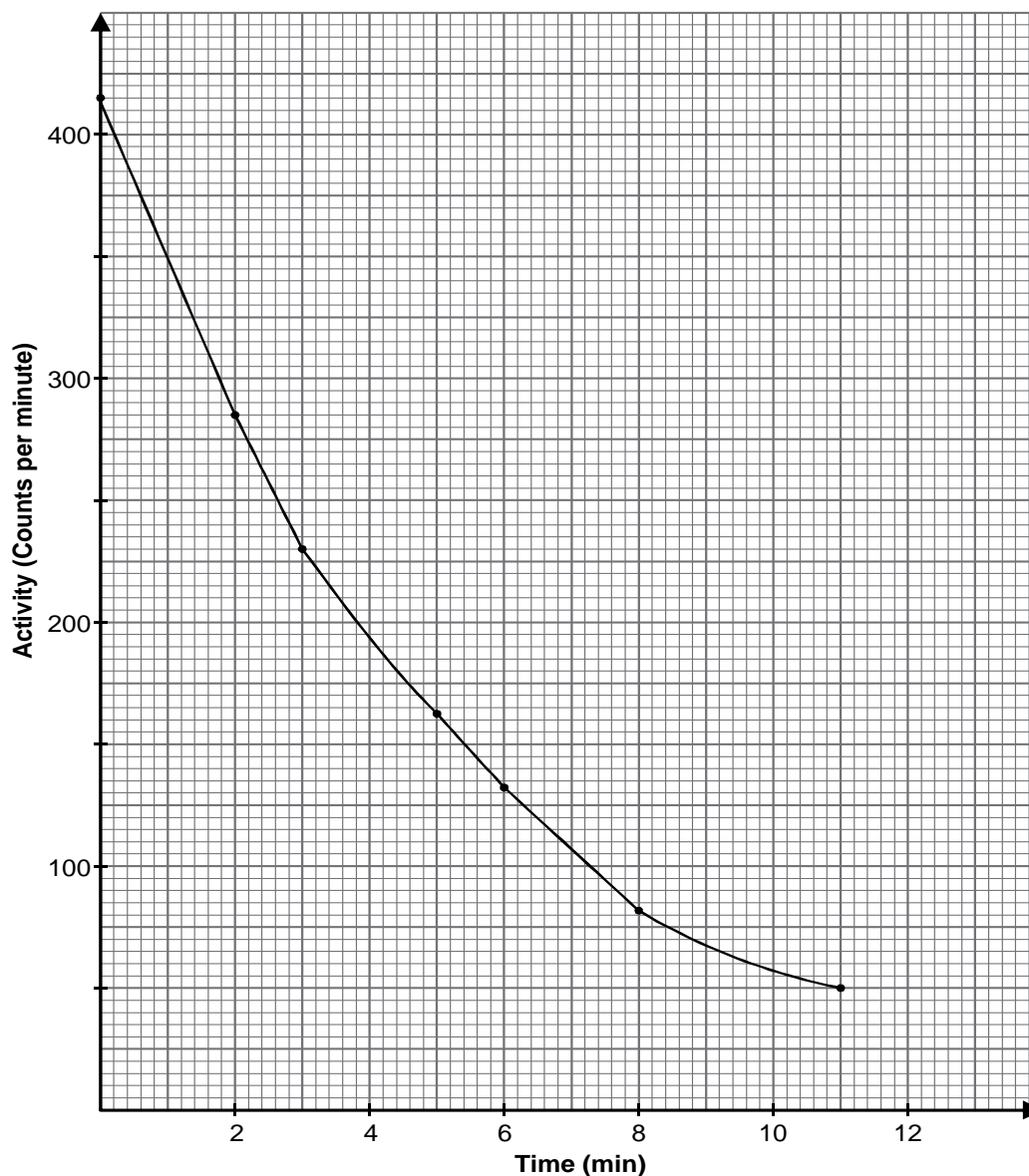

i) From the graph of activity against time above determine the half life of the nuclide.

(1 mark)

ii) Using the half life obtained in e(i) how long would it take for the count rate of fall from 320 counts per minute to 80 counts per minute.

(2 marks)

**NYERI COUNTY FORM FOUR JOINT ASSESSMENT**

Kenya Certificate of Secondary Education

232/3

**PHYSICS****Paper 3****July/August 2015**

1. You are provided with the following apparatus.

- Two retort stand + bosses + clamps
- Two pieces of thread (about 70cm long)
- Cellotape (2 pieces 10 cm long each)
- Half meter rule
- Metre rule
- Stop watch

Procedure

- a) Set up the apparatus as shown with suspending length,  $L$ , as 60cm and points of suspension be 5cm from the ends. Fix firmly with cellotape for half metre rule to remain horizontal.

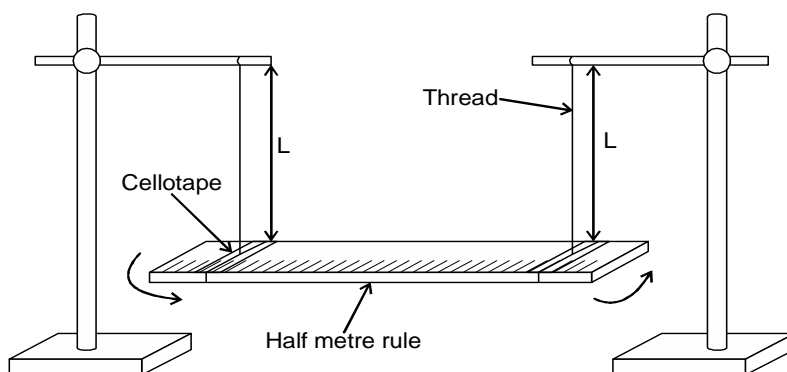

- b) Displace both ends of half metre rule through a small angle for the rule to make oscillations along a horizontal plane.  
 c) Determine and record time for 10 oscillations.  
 d) Adjust length,  $L$ , to 55cm, 50cm, 45cm, 40cm, 35cm and 30cm and repeat b and c above.  
 e) Record time,  $t$ , in the table below.

Length $L$ (cm)	Time for 10 oscillations $t$ (s)	Periodic time $T$ (s)	Log $L$	Log $T$
60				
55				
50				
45				
40				
35				
30				

- f) Plot a graph of  $\log T$  (y-axis) against  $\log L$  (x - axis) (7 marks)  
 g) Determine the slope,  $S$ , of the graph. (5 marks)  
 h) Given that  $T = KL^n$ , determine the value of  $n$ . (3 marks)  
 i) Use the graph to determine the value of  $K$ . (2 marks)  
 (3 marks)

2. **A.** You are provided with the following apparatus.

- Four optical pins
- 30cm ruler
- Protractor
- Soft board
- White plain paper
- Cellotape (about 10 cm long)
- 1 dry cell
- Ammeter
- Voltmeter
- Torch bulb
- Switch.
- 7 connecting wires. (4 with crocodile clip)

Procedure

- a) Trace the outline of the glass block on the white paper.  
 b) Draw a normal NK, 2cm from point A on side AB  
 c) Measure an angle (i)  $10^\circ$  from the normal.  
 d) Place back the glass block on the outline and fix a plane mirror on opposite side of AB, using a cellotape vertically along the length of block as shown.

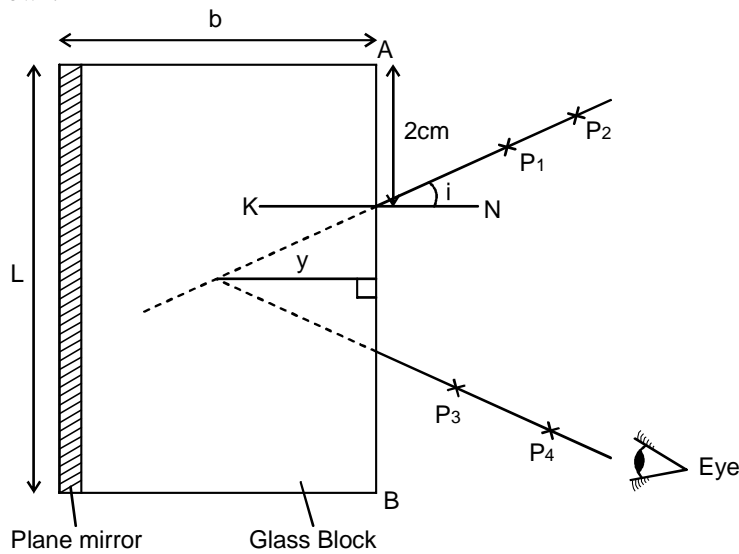

- e) Fix two pins  $P_1$  and  $P_2$  as shown in the figure.  
 f) By observing image of  $P_1$  and  $P_2$  locate two pins  $P_3$  and  $P_4$  such that they appear to be on line with images of  $P_1$  and  $P_2$   
 g) Remove the pins and the block. Join  $P_3 P_4$  and produce the line to meet line  $P_1 P_2$  produced. Measure the perpendicular distance  $y$ .  
 h) Repeat the same for angles of  $15^\circ$ ,  $20^\circ$ ,  $25^\circ$ ,  $30^\circ$ ,  $35^\circ$ , and  $40^\circ$  and record the results in the table below.  
 (NB: The paper work must be submitted together with the question paper.)

Angle $i$	$10^\circ$	$15^\circ$	$20^\circ$	$25^\circ$	$30^\circ$	$35^\circ$	$40^\circ$
$y$ (cm)							

- i) Plot a graph of  $y$  (cm) (y-axis) against angle  $i$  (x-axis.) (5 marks)  
 I) Use the graph to determine  $y_0$  the value of  $y$  when angle  $i = 0$   
 $y_0$  ..... cm (1 mark)  
 II) Measure and record breadth ( $b$ ) of the glass block.  
 $b$  ..... cm (1 mark)  
 III) Determine the value of  $\eta$  given that (2 marks)

$$\eta = \frac{b}{y_0}$$

- B. Set up the following circuit.

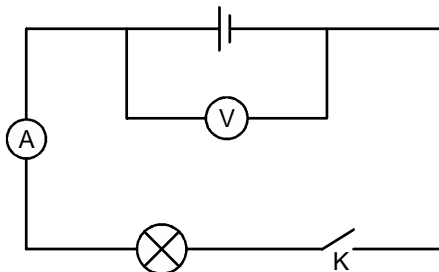

- I. Record the voltmeter reading when K is open  
 $V_i$  ..... cm (1 mark)  
 II. Close the switch and record the new reading of the voltmeter and ammeter.  
 $V_2$  ..... volts. (1 mark)  
 $I =$  ..... A (1 mark)  
 III. Given that  $E = I(R + r)$ , use the above results to determine the resistance,  $R$ , of the bulb. (3 marks)

**NYERI COUNTY FORM JOINT ASSESSMENT**

Kenya Certificate of Secondary Education

**PHYSICS**

Paper - 232/1

July/August - 2015

**MARKING SCHEME**

1. Volume of 50 drops  
 $= 0.14\text{cm}^3 \times 50$   
 $= 7\text{cm}^3$  ✓1  
 Burette reading  
 $= 35.6\text{cm}^3 + 7\text{cm}^3$   
 $= 42.6\text{cm}^3$  ✓1
2. Adhesive forces are greater than the cohesive forces. ✓1
3. Clockwise moments = anticlockwise moments ✓1  
 Accept  $F_1d_1 = f_2d_2$  for formula mark  
 $(20\text{cm} \times 30\text{N}) + (65\text{cm} \times F) = 50\text{cm} \times 40\text{N}$  ✓  
 $600 + 65F = 2000$

$$\begin{aligned} 65F &= 1400 \\ F &= \frac{1400}{65} \\ &= 21.54\text{N} \quad \checkmark 1 \end{aligned}$$

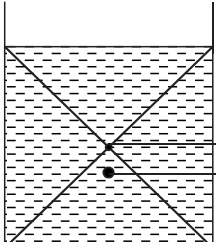
4. 

5.  $h_1d_1g = h_2d_2g$  ✓1  
 $\Rightarrow h_1d_1 = h_2d_2$

$$\begin{aligned} d_2 &= \frac{h_1d_1}{h_2} \\ &= \frac{0.8\text{gcm}^{-3} \times 22\text{cm}}{19\text{cm}} \\ &= 0.93\text{g/cm}^3 \end{aligned}$$

(Answer should be given to 2.sf)

6. As the temperature decreases, the kinetic energy of the gas molecules / particles decreases and thus rate of movement decreases OR  
 As the temperature decreases, the velocity of the gas molecules decreases and thus they move at a lower rate.
7. Steel and concrete expand / contract at the same rate unlike steel and aluminium which expand/ contract at different rates.  
 Accept: Steel and concrete have the same linear expansivity unlike aluminium and concrete.
8. - A ✓1  
 - Black surface is a better emitter of radiation as compared to the shiny surface and thus more heat is absorbed by thermometer A compared to thermometer B. ✓1

9.  $W = \frac{1}{2}Ke^2$  ✓1  
 $k = \frac{2W}{e^2}$   
 $= \frac{2 \times 0.08}{(0.05)^2}$  ✓1  
 $= 64\text{Nm}^{-1}$

10.- The light ball moves upwards.

- The pressure above the ball is lowered / becomes lower / reduces and thus atmospheric pressure / pressure below the ball pushes it upwards.

11.- The piece of thread becomes tight and stretches towards region Y.

- Surface tension force pulls the thread towards region y.



12. Displacement is distance in a specified direction while distance is length of space between the two points.

13.- The piston moves outwards / the piston moves towards the left.

- As the temperature increases, kinetic energy of the gas molecules increases and this increases the rate of collision between the gas molecules and walls of the container. This causes pressure of the gas to increase thus pushing the piston outwards.

14. Weight of B should be greater than the frictional force between block A and the surface.

### SECTION B

15.a) Speed is ratio of distance moved to time taken while velocity is ratio of displacement covered to the time taken.

b)- B

- Acceleration of A is greater than that of B and thus A needs greater force than B.

c) i)  $V^2 = U^2 + 2as$

$$48^2 = 26^2 + 2 + 2 \times S$$

$$S = \frac{48^2 - 26^2}{4}$$

$$= 407 \text{ m}$$

ii)  $F = \frac{m(v - u)}{t}$

$$= \frac{27(0 - 48)}{12}$$

$$= -168 \text{ N}$$

16.

a) 2

b)  $V.R. \text{ of inclined plane} = \frac{\text{Distance moved by effort}}{\text{Distance moved by load}}$

$$= \frac{8}{2} = 4$$

$$\frac{1}{\sin \theta} = \frac{1}{\frac{2}{8}} = 4$$

$$\therefore V.R. = \frac{1}{\sin \theta}$$

- c) i) -increase the length of the incline  
- reduce the angle of inclination

- ii) - reduce the angle of inclination  
- reduce friction between load and inclined surface.

d) i) W = work done against gravity + work done against friction  
=  $mgh + Fd$  ✓1  
=  $1000 \times 2 + 50 \times 8$  ✓1  
=  $2000 + 400$   
=  $2400 \text{ J}$  ✓1

ii)  $e = \frac{\text{work done on load}}{\text{work done by effort}} \times 100\%$  ✓1  
=  $\frac{1000 \times 2}{2400} \times 100$   
=  $\frac{2000}{2400} \times 100$  ✓1  
=  $83.3\%$

17. a) Amount of heat required to raise temperature of 1kg mass of a substance by 1k.

b) i) To ensure that the temperature of the furnace is maintained by the solid material / to ensure minimum heat loss to the surroundings during transfer.

- ii) - Error while reading the thermometer  
- Error while taking reading of the mass.  
- There is heat lost to the surrounding during transfer.

c) i)  $H = 0.05 \times C_m \times (600 - 100)$  ✓1  
=  $25 C_m$

ii)  $H = M_C C_C \theta_C + m_w C_w \theta_w + ml_v$   
=  $(0.04 \times 390 \times 30) + (0.02 \times 4200 \times 30)$   
+  $(0.005 \times 2260000)$   
=  $468 + 2520 + 11300$   
=  $14288 \text{ J}$

$$\begin{aligned} \text{iii) } H &= MC\theta \quad \checkmark \\ 14288 &= 25Cm \quad \checkmark \\ C_m &= \frac{14288}{25} \\ &= 571.52 \text{ Jkg}^{-1}\text{k}^{-1} \quad \checkmark \end{aligned}$$

18.

- a) When a body is wholly or partially immersed in a fluid, it experiences an upthrust equal to the weight of the fluid displaced  $\checkmark$
- b) i) Adding some heavy mass / sand into the test-tube  
 ii) Dip the test-tube in liquids of different densities and mark the level to which the tube floats in each.  
 iii) Using a test-tube of lower radius / using a thinner test tube.
- c) i) Upthrust  
 = weight of liquid displaced  $\checkmark$   
 $\frac{2}{100} \times \frac{4}{100} \times \frac{8}{100} \times 1250 \times 10$   
 $100 \quad 100 \quad 100$
- ii) Weight of block = Upthrust  
 = 0.8 N
- iii) Force = weight of fluid to be displaced  $\checkmark$   
 =  $0.04 \times 0.04 \times 0.02 \times 1250 \times 10$   
 = 0.4N  $\checkmark$

19. a) Angular velocity is the rate of change of angular displacement with time.

- b) i) Increasing the speed of rotation of the small mass  
 ii) Velocity of the small mass increases.
- c) i) Direction of motion of the stone changes continuously.  
 ii)  $V = wr$   
 =  $6.28 \times 1$   
 =  $6.28 \text{ ms}^{-1} \quad \checkmark$

$$\begin{aligned} \text{iii) } T &= \frac{2\pi}{w} \\ &= \frac{2 \times \pi}{6.28} \end{aligned}$$

$$= 1 \text{ second or } 1 \text{ S}$$

$$\begin{aligned} \text{iv) } V &= \sqrt{rg} \\ &= \sqrt{1 \times 10} \\ &= 3.16 \text{ m/s} \end{aligned} \quad \left. \vphantom{\begin{aligned} V &= \sqrt{rg} \\ &= \sqrt{1 \times 10} \\ &= 3.16 \text{ m/s} \end{aligned}} \right\} \checkmark \quad \checkmark$$

- d) - Highest speed expected  
 - Radius of the band.

**NYERI COUNTY FORM JOINT ASSESSMENT**

Kenya Certificate of Secondary Education

**PHYSICS**

Paper - 232/2

July/August - 2015

**MARKING SCHEME**

1. Angle of incidence =  $90^\circ - 32^\circ = 58^\circ$  ✓  
Angle of reflection = angle of incidence =  $58^\circ$  ✓
2. i) Frequency remains CONSTANT ✓  
ii)  $V = \lambda f$   
 $24\text{cm/s} = f \times 8\text{cm}$  ✓  
 $f = 3\text{Hz}$  ✓
3. Speed of sound in air INCREASES ✓

4.

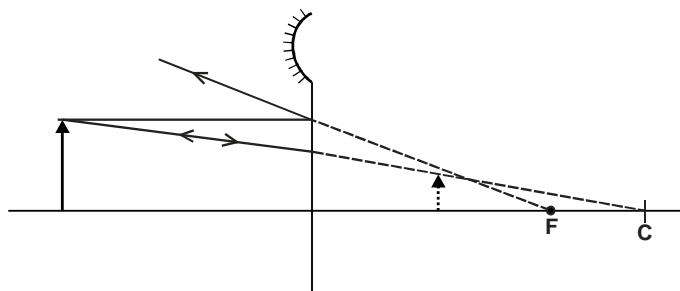

either - one ray parallel - incident to mirror ✓

Location of F ✓

OR

Ray through C ✓

Location of f ✓

5.  $v \times t = 2x$   
 $340 \times 1.7 = 2x$  ✓  
 $x = 289\text{ m}$  ✓

6.

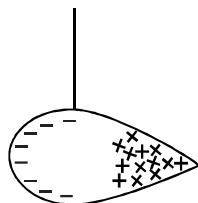

Metallic object

Distribution of charge ✓

More concentration of positive charge at sharp point. ✓

7. Bulbs in set up B ✓  
Efficiency emf is greater in B than in A ✓  
p.d across bulbs in B is higher than the p.d. across bulbs in A ✓

8.  $E = I(R + r)$  ✓  
 $E = 0.5(R + r)$   
 $r = \frac{E}{0.5} - R$  ✓

9.  $H = \frac{V^2 t}{R} = \frac{12^2 \times 60}{20} = 432\text{ J}$  ✓

10. Increasing speed of rotation of coil.  
Increasing the number turns  
Using a stronger magnet.

any one ✓

11. Main fuse is on the neutral wire ✓  
Main switch is on the neutral wire ✓

12.

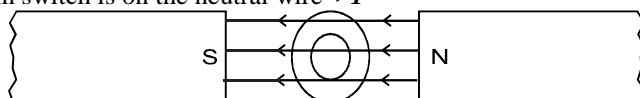

13.

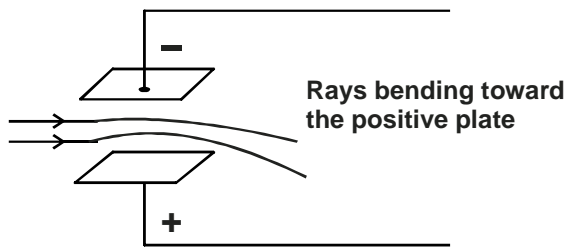

14.

a) Different refractive index of the two liquids since.

$$\text{OR } n = \frac{\text{Real depth}}{\text{apparent depth}}$$

refractive index of P is less than that of q ✓1

b)

$$n_g = \frac{1}{\sin C} = \frac{1}{\sin 42} = 1.5$$

$$\frac{\sin 40}{\sin x} = 1.5 \quad x = 25.4^\circ$$

c)

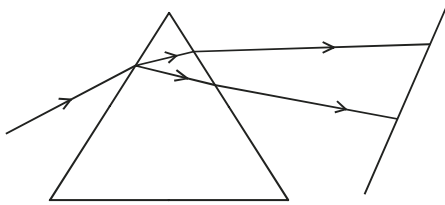

d) i)

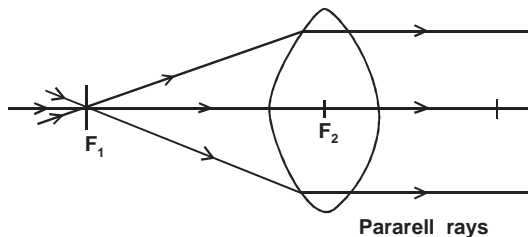

ii) eye ball too long ✓1

iii) B<sub>1</sub> concave lens ✓1

$$e) \quad m = \frac{V}{f} - 1 \quad \checkmark 1$$

$$\text{Gradient} = \frac{1}{f}$$

$$\text{Gradient} = \frac{1-0}{20-10} = \frac{1}{10} = 0.1$$

$$\frac{1}{f} = 0.1$$

$$f = 10\text{cm}$$

15.a) Leaf in A decreases in divergence

B increases in divergence electrons flow from B to A ✓1

b) P is negatively charged ✓1 The body repels more negative charge from the cap to the leaf. ✓1

$$c) \quad C_T = \frac{2 \times 2}{2+2} + \frac{3 \times 3}{3+3} = 2.5 \mu F$$

$$Q = CV$$

$$= 2.5 \times 10^{-6} \times 3 = 7.5 \times 10^{-6} C$$

d) Decreasing distance between plates.

- Increase area of overlap of the plates

- using a dielectric with a higher dielectric constant.

(any two ✓1 ✓1)

16. i)  $R_1$  - to vary anode voltage ✓  
 ii)  $R_2$  - to vary filament current ✓

b) i)  $It = n \times e$  ✓

OR

$$0.01\text{A} \times 1 = n \times 1.6 \times 10^{-19}\text{C}$$

$$n = \frac{0.01}{1.6 \times 10^{-19}}$$

$$n = 6.25 \times 10^{16} \text{ electrons } \checkmark$$

ii)  $P = 1\text{V}$  ✓

$$0.01 \times 50,000 \text{ V} = 500 \text{ w } \checkmark$$

iii) Heat energy =  $\frac{99.5}{100} \times 500 = 497.5\omega$  ✓

OR

$$\frac{0.5}{100} \times 500 = 2.5 \omega \checkmark$$

100

$$500 - 2.5 = 497.5\omega \checkmark$$

iv)

$$ev = h \frac{c}{\lambda} \quad \checkmark$$

$$\lambda = \frac{6.63 \times 10^{-34} \times 3 \times 10^8}{1.6 \times 10^{-19} \times 50000} \quad \checkmark$$

$$= 2.486 \times 10^{-11} \text{ m} \quad \checkmark$$

17. a) Work function is the minimum energy required to dislodge / eject an electron from the metal surface ✓

- b) i) - work function of the metal ✓  
 - frequency of incident radiation ✓

ii) Increasing intensity of radiation ✓

c) i)  $E = hf$

$$6.63 \times 10^{-34} \times 8 \times 10^{14} \checkmark$$

$$5.03 \times 10^{-19} \text{ Joules } \checkmark$$

ii)  $E = W_0 + K_e$  ✓

$$5.304 \times 10^{-19} = 2.16 \times 10^{-19} + K_e \checkmark$$

$$K_e = 2.104 \times 10^{-19} \text{ Joules } \checkmark$$

18.

- a) In conductors the valency band and the conduction band overlap while in semiconductors there is a small gap (forbidden gap) in between them.

- b) Bulb 1 and bulb 2 will light with the same brightness, since diode two is reverse biased.

c) i) X = beta particle ✓

$$m = 230 \checkmark \quad n = 89 \checkmark$$

- d) i) A is alpha particle

- Positively charged massive, high ionising power low penetrating power.(any one) ✓

ii) B - is gamma ray - used in treatment of cancer, detecting metal flows, sterilization determining thickness of metal sheets (any one) ✓

e) i) half life 3.6 minutes  $\pm 0.01$  ✓

ii)  $\left(\frac{1}{2}\right)^n = \frac{80}{320} \left(\frac{1}{2}\right)^n = \frac{1}{4} \quad n = 2$

$$2 \times 3.6 = 7.2 \text{ minutes } \pm 0.02$$

**NYERI COUNTY FORM JOINT ASSESSMENT**

Kenya Certificate of Secondary Education

**PHYSICS**

Paper - 232/3

July/August - 2015

**MARKING SCHEME**

1. e)

Length L(cm)	Time for 10 oscillations t(s)	Periodic time T(s)	Log L	Log T
60	11.22	1.122	1.778	0.0499
55	9.93	0.993	1.74	-0.00305
50	9.28	0.928	1.699	-0.032
45	8.96	0.896	1.653	-0.0476
40	8.75	0.875	1.6	-0.057
35	8.22	0.822	1.54	-0.085
30	7.5	0.7523	1.47	-0.123

g)

$$S = \frac{Dy}{Dx}$$

$$= \frac{2.0 - 0}{17.6 - 16.8} = \frac{2.0}{0.8} = 2.5$$

$$T = KL^n$$

$$\text{Log}T = \log K + n\text{Log}L \quad / \quad \text{Log}T = n\text{Log}L + \log K$$

$$\therefore n = \text{slope} = 2.5 \quad \checkmark 1$$

i)  $C = \log k \quad \checkmark 1$

y - intercept

$$\log k = 34.4 \times 10^{-2}$$

$$k = \text{anti log } 34.4 \times 10^{-2} \quad \checkmark 1$$

$$= 2.208 \quad \checkmark 1$$

**GRAPH****Question 2**

$i^\circ$	10	15	20	25	30	35	40	
y(cm)	4.5	4.3	4.1	3.9	3.7	3.5	3.4	$\pm 0.1$

Each point 1 mark for maximum 5 points - 5 marks

**GRAPH**

i) I.  $y_0 = 4.9\text{cm}$

II.  $b = 6.1\text{cm} \pm 0.1$  **1 mark**

III.  $n = \frac{b}{y_0}$  Substitution -  $\frac{1}{2}$  mark

Evaluation -  $\frac{1}{2}$  mark

Accuracy - 1 mark (1.20 - 1.54)

j)  $V_1 = 1.5\text{V} \pm 0.1$  **1 mark**

$V_2 = 1.3\text{V}$  **1 mark**

$I = 0.8\text{A}$  **1 mark**

$E = IR + IV$  **1 mark**

$V_1 = E$

$V_2 = IR$  **1 mark**

$$R = \frac{V_2}{I} = \frac{1.3}{0.8} = 1.625\Omega \quad \text{1 mark}$$

# BELOW ( MAKUENI COUNTY) IS A REVISION EXERCISE

## MAKUENI COUNTY KCSE 2015 PREPARATORY EXAMINATION

Kenya Certificate of Secondary Education

232/1

PHYSICS

Paper 1

(THEORY)

2015

### SECTION A (25 MARKS)

Answer **all** the questions in this section in the spaces provided.

1. The diameter of a ball bearing of mass 0.0045 kg is measured using a micrometer screw gauge as shown in Figure 1 below.

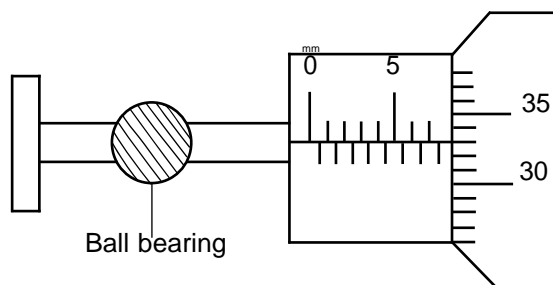

Figure 1

- (a) Determine the radius of the ball bearing. (1 mark)
- (b) Determine the density of the ball bearing. (Take  $\pi = 3.142$ ) (2 marks)
2. A body exerts a pressure of  $100 \text{ N/mm}^2$ . Express this in SI units. (1 mark)
3. The diagram below shows the levels of mercury and water in beakers.

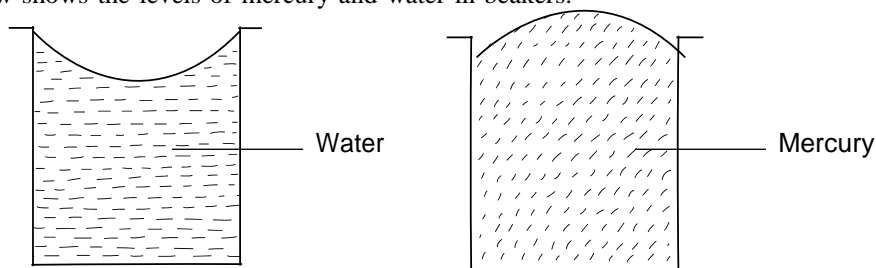

Figure 2

- Explain the difference in the shape of the meniscus. (2 marks)
4. Figure 3 below shows a rod made of wood on one end and metal on the other end. It is suspended freely with a piece of thread so that it is in equilibrium.

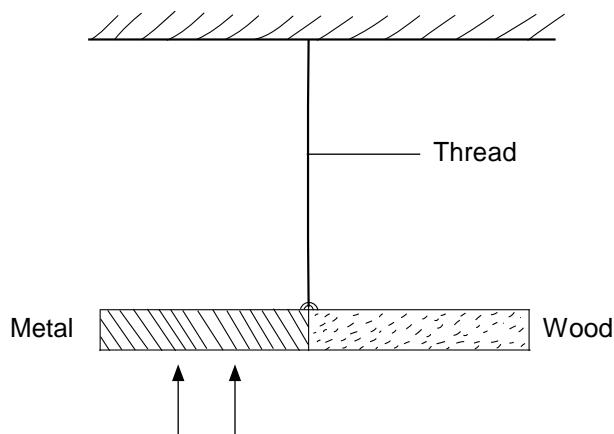

Figure 3

- The side made of metal is heated with a Bunsen flame and the rod tips to the left. Explain. (1 mark)
5. Convection and diffusion both involve motion of fluid molecules. Distinguish between the two. (1 mark)

6. Three identical springs each of spring constant  $10 \text{ N/M}$  and weight  $0.5 \text{ N}$  are used to support a load as shown. Determine the total extension of the system. (2 marks)

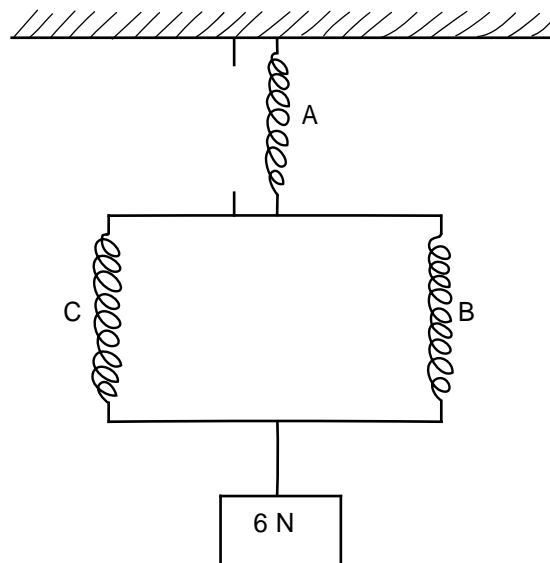

Figure 4

7. As Mariga was taking a penalty kick, his leg moved through an angular displacement of  $90^\circ$ . If his leg is  $1.2 \text{ m}$  long, calculate the distance moved through by the end of Mariga's foot. (2 marks)
8. A non-uniform plank of wood AB of mass  $0.50 \text{ kg}$  balances on a point K  $0.15 \text{ m}$  from the end A when a  $0.24 \text{ kg}$  mass is suspended from one end as shown.

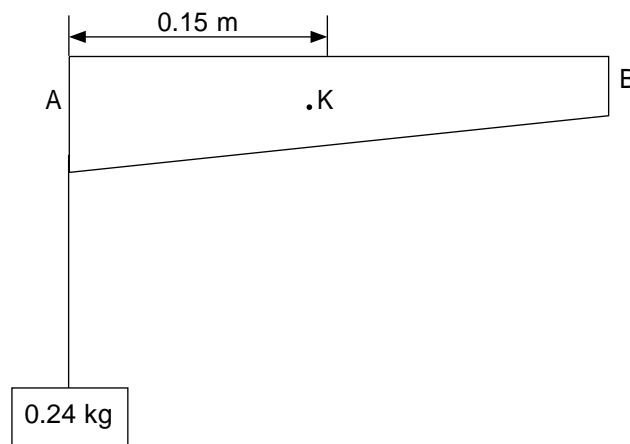

Figure 5

- Determine the distance of the centre of gravity of the plank from end A. (2 marks)
9. The diagram shows a cross-section of an aeroplane wing when the aeroplane is moving at constant height and constant speed. An upward force equal and opposite to it is exerted on its wing as shown in Figure 6.

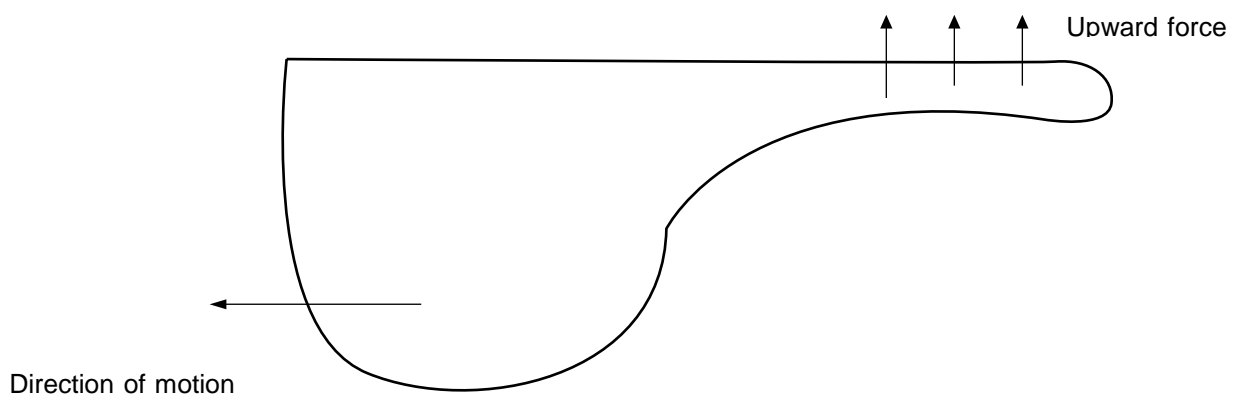



Figure 6

- (a) What is the cause of the upward force? (1 mark)
- (b) Why is the shape of the wing crucial in producing this upward force? (1 mark)

10. Tracy drew the graph below (Figure 7).

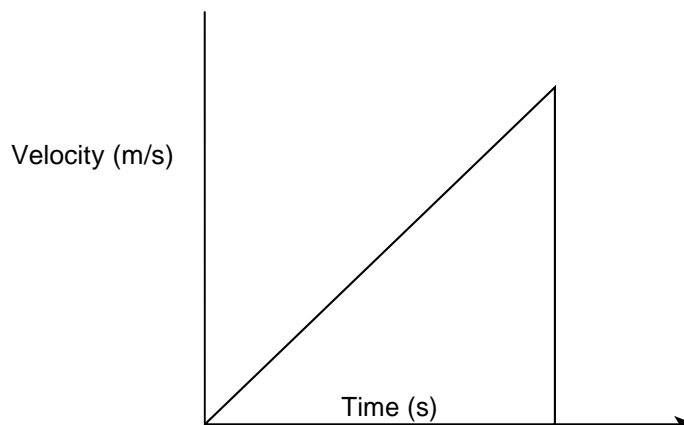

Figure 77

She then worked out the area of the shaded part. State what she was determining. (1 mark)

11. It is impossible to reduce the pressure of a gas to zero. Explain. (1 mark)
12. The figure below shows a block of volume  $50 \text{ cm}^3$  and density  $2\,000 \text{ kg/m}^3$  submerged in a liquid and suspended from a homogeneous horizontal beam by means of a thread. The beam is balanced by a spherical mass of  $40 \text{ g}$ , which is suspended from it on the other side of the pivot as shown in

Figure 8.

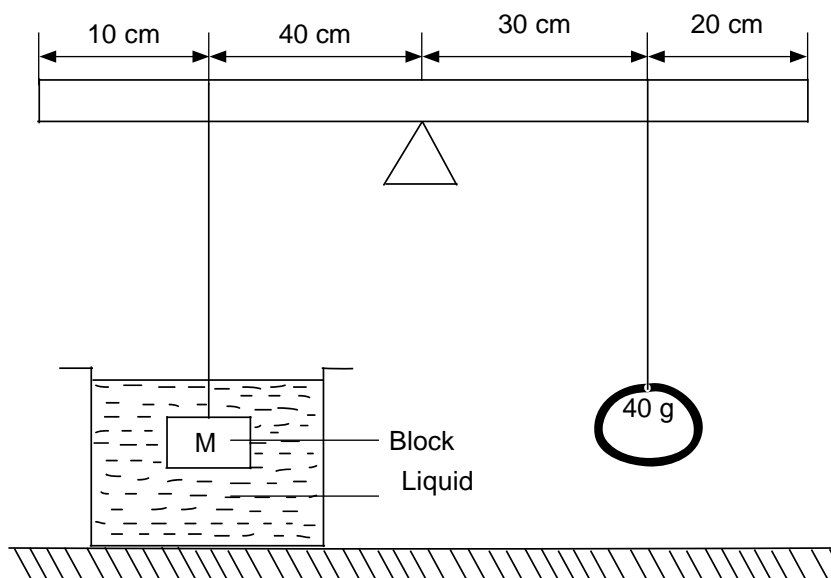

Figure 8

Determine the upthrust force acting on the block. (3 marks)

13. Figure 9 below shows two stationary trolleys A and B separated by a compressed spring and held together by an inextensible thread. The mass of trolley A is  $2.0 \text{ kg}$  and that of trolley B is  $0.1 \text{ kg}$ . When the thread is cut, the trolleys move rapidly apart.

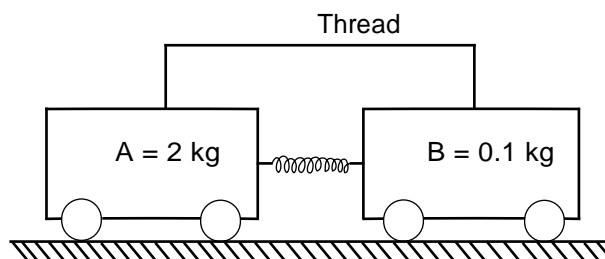

Figure 9

- (a) State the energy changes that occur when the string is cut. (1 mark)
- (b) If trolley A moves off with a speed of  $0.48 \text{ m/s}$ , calculate the speed with which trolley B moves off. (2 marks)

14. A load was raised using the system shown below as in Figure 10 (a). The system was then modified as shown in Figure 10 (b) and used to raise the same load.

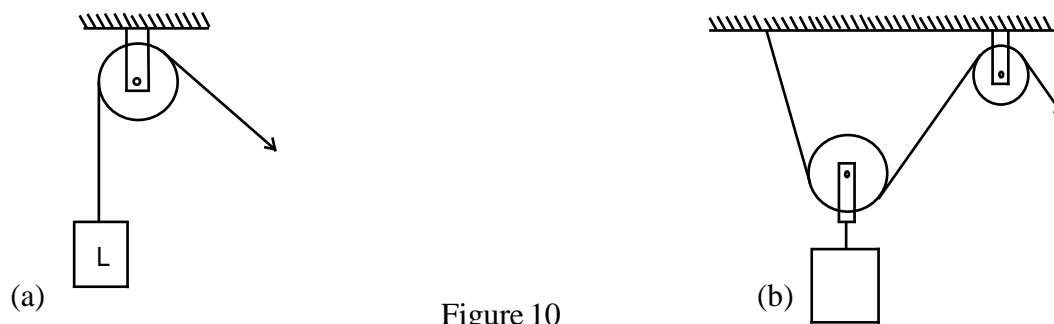

Figure 10

Explain the change in efficiency.

### SECTION B (55 MARKS)

Answer *all* questions in this section in the spaces provided after each question.

15. (a) Define the term relative density. (1 mark)
- (b) A balloon of negligible weight and a capacity of  $80 \text{ m}^3$  is filled with helium gas whose density is  $0.18 \text{ kg/m}^3$ . Given that the density of air is  $1.1 \text{ kg/m}^3$ , calculate:
- the upthrust force on the balloon. (2 marks)
  - the weight of helium. (2 marks)
  - the lifting force of the balloon. (2 marks)
- (c) Draw a force diagram showing all the forces acting on the balloon as it floats. (2 marks)
- (d) An experiment was carried out to determine the relative density of a liquid by applying Archimedes principle. The table below shows the results that were obtained using various masses.

Table 1			
Object	A	B	C
Mass (kg)	0.2	0.3	0.4
Weight in air (N)	2.0	3.0	4.0
Weight in Liquid X (N)	1.82	2.72	3.64
Weight in water	1.76	2.64	3.52
Upthrust in water (N)			
Upthrust in Liquid X (N)			

- Complete the table. (2 marks)
  - Determine the average relative density of Liquid X. (2 marks)
16. (a) Define the term latent heat of fusion of a substance. (1 mark)
- (b) Figure 11 below shows an apparatus that could be used to determine the specific latent heat of fusion of ice.

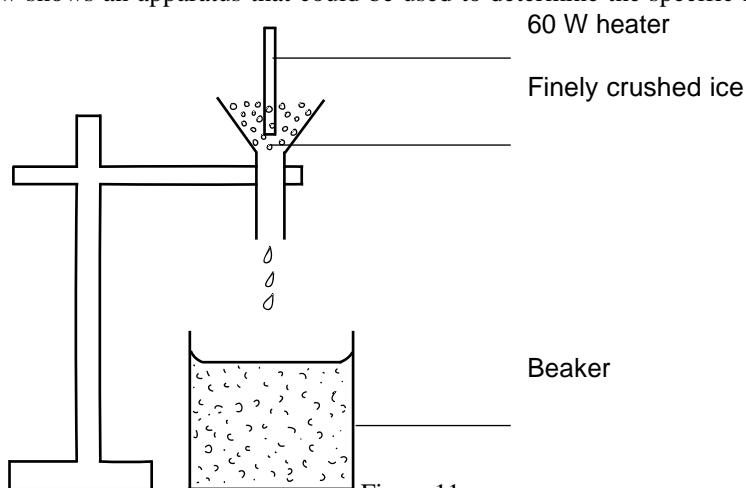

Figure 11

- In order to obtain results that are as accurate as possible, state why it is important to:  
I. wait until water is dripping into the beaker at constant rate before taking readings. (1 mark)

- II. use finely crushed ice rather than larger ones. (1 mark)
- (ii) The power of the heater and the time for which water is collected are known. Write down all other readings that are needed to obtain a value for a specific latent heat of fusion of ice. (2 marks)
- (c) In an experiment to measure the specific heat capacity of a liquid, a quantity of the liquid was heated in a copper calorimeter. The following measurements were obtained:

Mass of calorimeter = 53.0 g  
 Mass of calorimeter + liquid = 142.6 g  
 Initial temperature of calorimeter + liquid = 16°C  
 Final temperature of calorimeter + liquid = 21°C  
 Energy supplied = 1168J

Using the above measurements, calculate the value of the specific heat capacity of the liquid.

(specific heat capacity of copper = 390Jkg<sup>-1</sup>K<sup>-1</sup>.)

(7 marks)

17. (a) Distinguish between velocity and speed. (2 marks)
- (b) The velocity-time graph in Figure 12 below illustrates the motion of a ball which has been projected vertically upwards from the surface of a planet. Weight of the ball on Earth is 30 N.

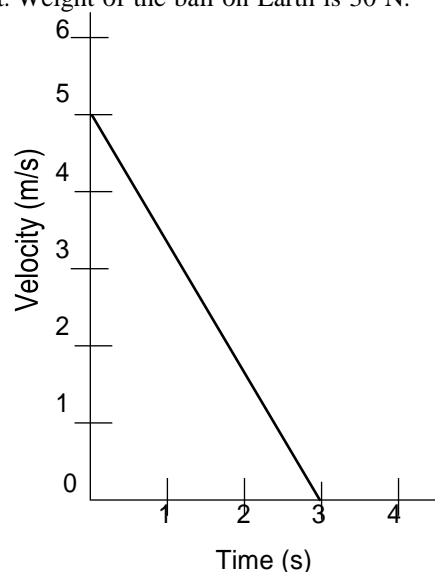

Figure 12

Determine the weight of the ball on the planet, if gravitational field strength on Earth is 10 N/kg.

(4 marks)

- (c) The figure below shows a section of a tape from a ten tick timer whose frequency is 50 Hz.

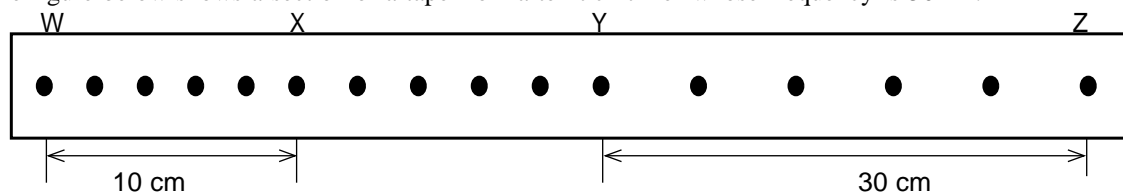

Figure 13

Calculate:

- (i) the average velocity of the trolley between points WX. (2 marks)
- (ii) the average velocity of the trolley between YZ. (2 marks)
- (iii) the acceleration of the trolley. (2 marks)

18. (a)
- (i) State the pressure law. (1 mark)
- (ii) Define an ideal gas. (1 mark)
- (iii) Define the absolute zero temperature. (1 mark)
- (b) Using Boyle's Law, explain the changes in the size of a gas bubble from the bottom of a deep dam to the point that it reaches the surface of the water. (3 marks)
- (c) During the promulgation of the new Constitution, a hydrogen-filled balloon with a volume of 0.027 m<sup>3</sup> was released at Uhuru Park from the ground where the pressure was 675 mmHg and the temperature was 25°C. The balloon rose to a height of 2700 m above the ground where the pressure had fallen to 450 mmHg and the temperature to 10°C. Determine the new volume of the balloon. (4 marks)
19. (a) State the limitation of Hooke's Law. (1 mark)

- (b) An experiment was performed to find out how the length,  $l$ , of a spring varies with the compressing force,  $F$ . The results were recorded in the graph below.

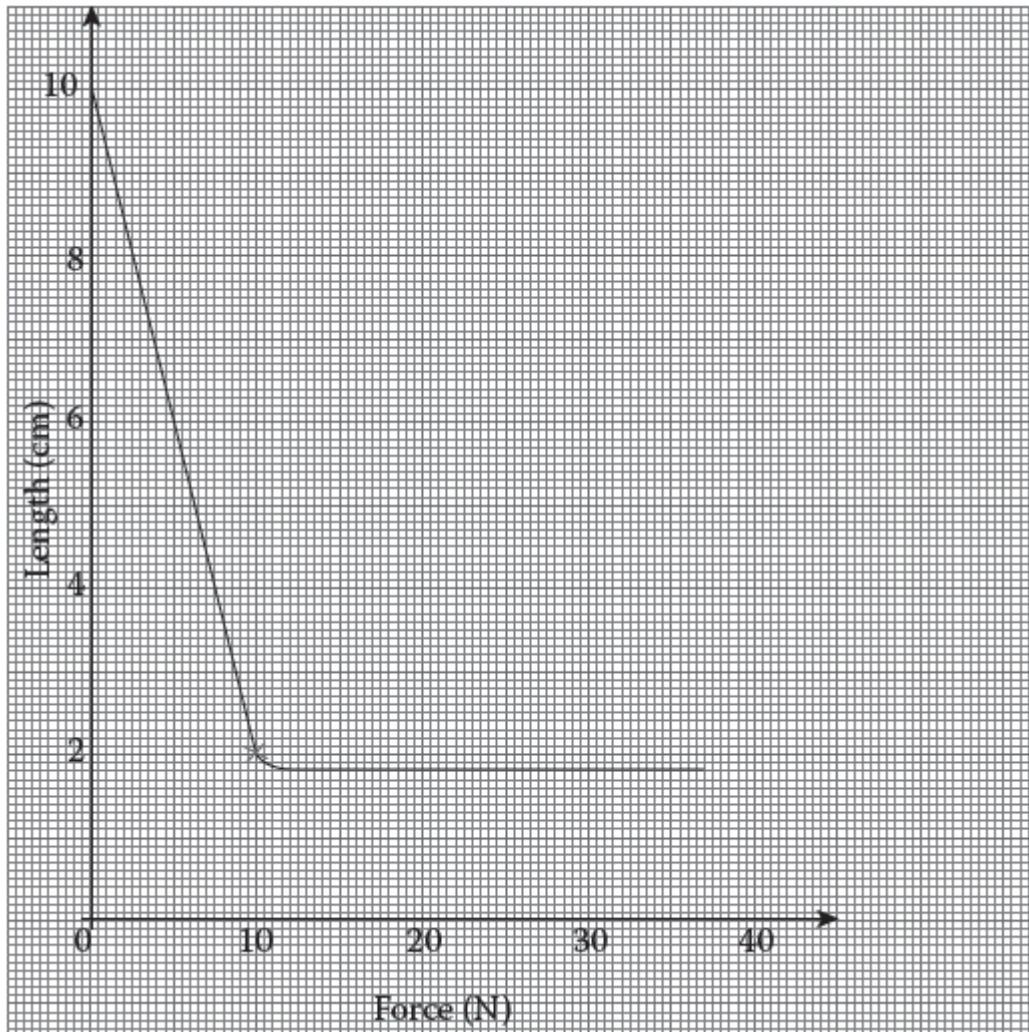

- (i) Draw a diagram showing the possible set-up of the apparatus used. (2 marks)
- (ii) Determine the range of force that the spring obeys Hooke's Law. (1 mark)
- (iii) Suggest a reason for the shape of the graph between 20 N and 30 N force. (1 mark)
- (c) A spring balance produces an extension of 12 mm when a force of 0.6 N is applied to it. Calculate the spring constant for the system when two such springs are arranged i

**MAKUENI COUNTY KCSE 2015 PREPARATORY EXAMINATION**
**Kenya Certificate of Secondary Education**
**PHYSICS**
**Paper 2**
**(Theory)**

2 hours

**SECTION A (25 marks)**

 Answer **all** the questions in this section in the spaces provided.

1. The figure below shows a ray of light being reflected from a plane mirror.

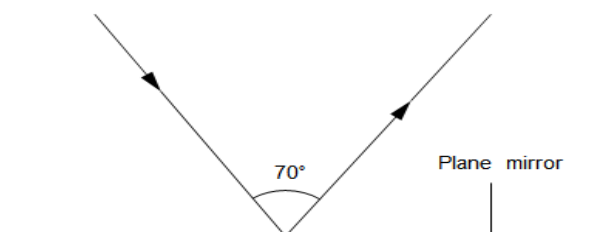
**Figure 1**

The plane mirror is then rotated clockwise through  $20^\circ$  keeping the incident ray fixed. What would be the new angle of reflection?

(1 mark)

2. When a highly charged polythene rod is brought close to a positively charged leaf electroscope, it is observed that the leaf initially falls and then rises.

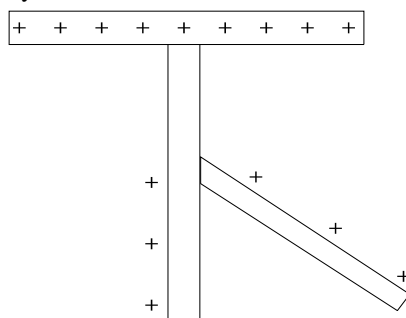

(a) State the charge on the polythene rod.

(1 mark)

(b) Explain the above observation.

(1 mark)

3. Explain briefly how polarisation occurs in a simple cell and state how the defect is minimised.

(2 marks)

4. The figure below shows a positively charged conductor suspended by a silk thread. The N-Pole of a magnet is brought close but does not touch it as shown.

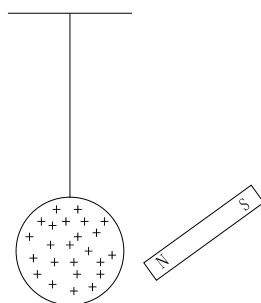
**Figure 3**

With a reason, state the observation made

(2 marks)

5. A white paper is a good reflector of light but does not form an image like a concave mirror. Explain this observation.

(2 marks)

6. The figure shows two parallel current conductors P and R which are close to each other. Both conductors have current flowing as shown.

- (a) On the figure:  **Figure 4**
- (i) sketch the magnetic field pattern. (1 mark)
- (ii) indicate the force  $F$  due to the current on each conductor. (1 mark)
- (b) Explain the cause of the force. (1 mark)

7. The figure below shows a wave profile for a wave whose frequency is 5 Hz.

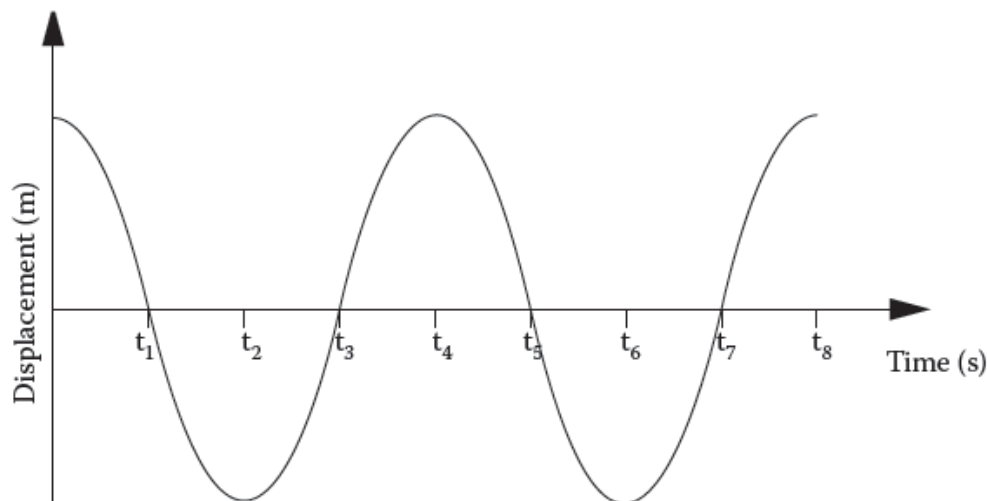

**Figure 5**

Determine the value of  $t_5$ .

8. Distinguish between thermionic emission and photoelectric effect. (1 mark)
9. The figure below shows a circuit involving two resistors and a capacitor connected to 6 volts source.

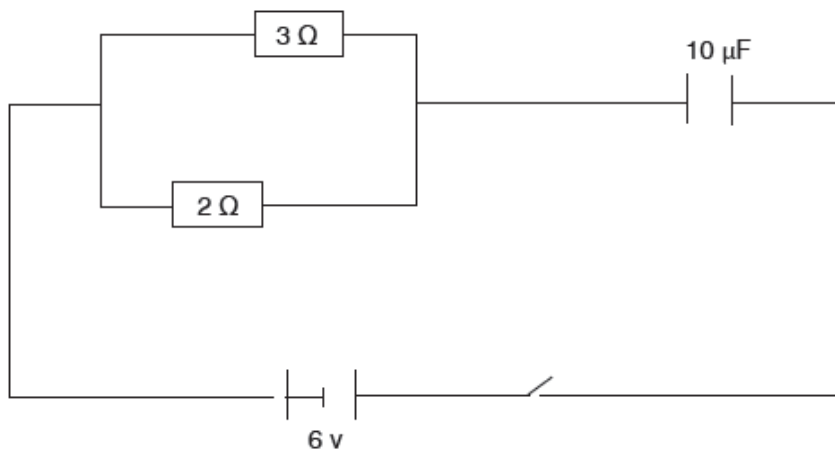

**Figure 6**

- (a) Determine the current in the circuit when the switch is closed. (2 marks)
- (b) Find the charge stored on the capacitor when fully charged. (2 marks)
10. When an electrician does domestic wiring, she connects lamps in the lighting circuit in parallel and not in series. Give two reasons for this requirement. (2 marks)
11. State the purpose of the presence of argon and nitrogen gases at low pressure inside a filament lamp. (1 mark)
12. The leaf of an electroscope falls when ultraviolet radiation is directed into a zinc plate placed on the cap of the electroscope. Identify the charge on the electroscope and explain the observations made. (2 marks)
13. Distinguish between a region of compression and a rarefaction in a longitudinal wave. (1 mark)

**SECTION B (55 marks)**

Answer *all* the questions in the spaces provided in this section.

14. (a) (i) State one condition under which Ohm's law must be obeyed. (1 mark)

(ii) The circuit diagram below shows two cells each of e.m.f  $E$  volts and internal resistance  $0.5$  ohms supplying a current to a network of resistors. When switched on the ammeter reading is found to be  $0.2A$ . Determine the value of  $E$ .

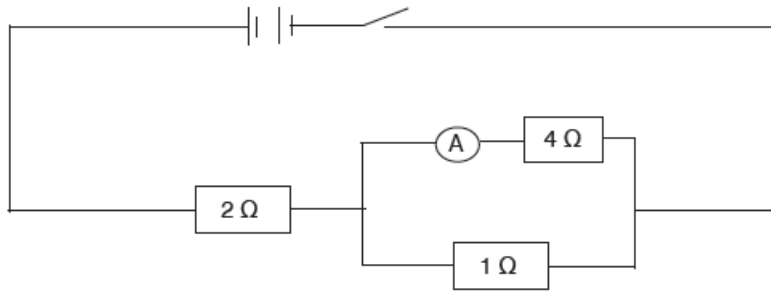

Figure 7

(b) A piece of red-hot charcoal is brought close to the cap of a negatively charged electroscope using tweezers. Explain what is observed.

(c) A transformer has 1000 turns in its primary coil which is connected to a  $250$  V a.c supply. The secondary is connected to an ammeter via a  $100$  ohm resistor. Determine the number of turns in the secondary coil if the ammeter reads  $1.5A$ .

(3 marks)

(d) Explain the working of a circuit breaker as a safety device.

(1 mark)

(e) The power company supplies electrical energy and charges the consumption to ordinary domestic consumers as follows:

A monthly fixed charge of Kshs. 75

Kshs. 1.55 per unit for the first 50 units consumed

Kshs. 6.65 per unit for the next 51–300 units

A consumer uses  $1.98 \times 10^5$  kilojoules of electrical energy in a given month. Determine the total month's bill.

(1 unit = 1 Kilowatt - hour (kWh))

(3 marks)

15. (a) The graph below shows radioactive decay of iodine

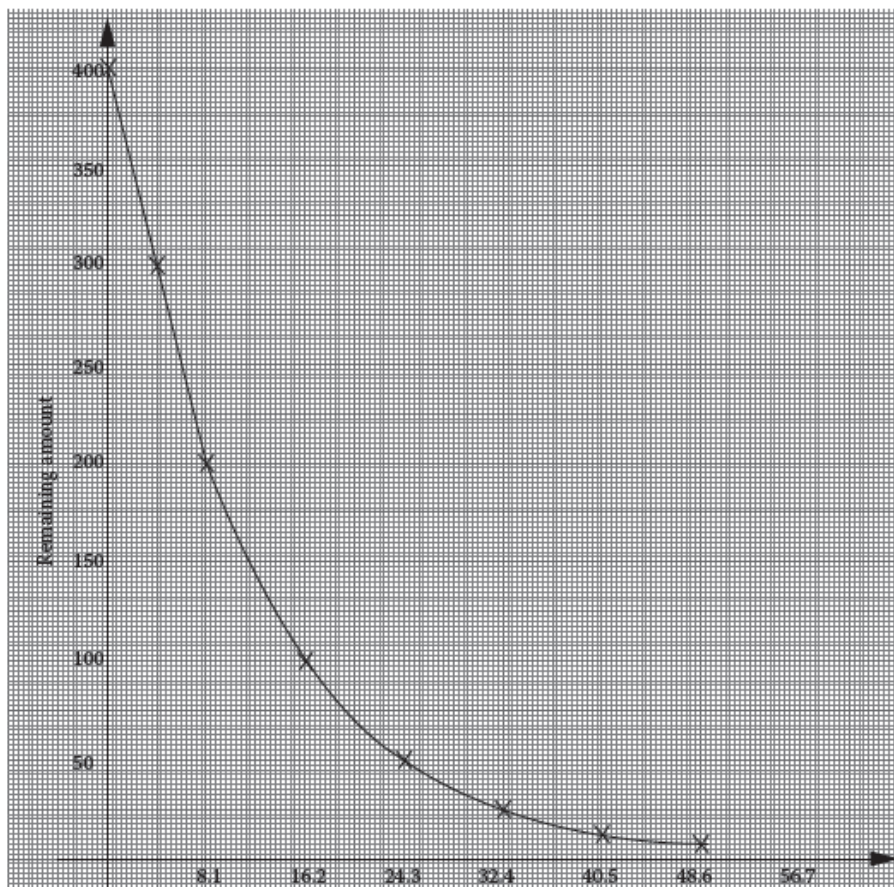

Use the graph to determine the:

- (i) fraction of the amount remaining after 16.2 days. (1 mark)  
 (ii) half-life of iodine. (1 mark)
- b) i) distinguish between nucleus and nuclear fission. (2 marks)  
 (ii) The following nuclear reaction is part of a radioactive series.

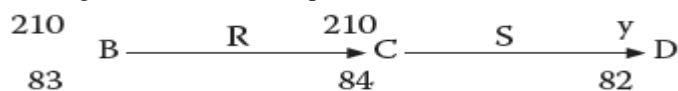

Name the radiations represented by R and S. (2 marks)

- c) The diagram below shows a diffusion cloud chamber for detecting radioactivity.

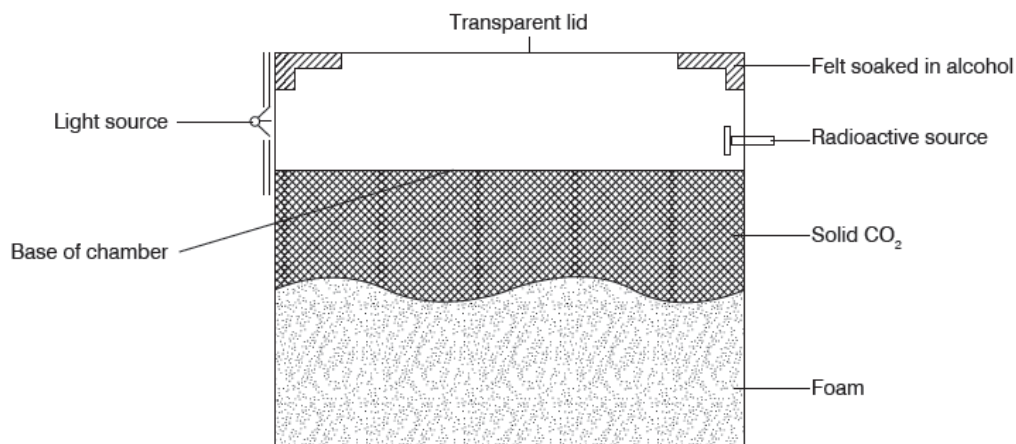

State the function of the following:

- (i) Alcohol (1 mark)  
 (ii) Solid  $\text{CO}_2$  (1 mark)
- (d) In an experiment using a cloud chamber, the following tracks were obtained.



Identify each of the tracks and explain why they are different. (3 marks)

- (e) The activity of a radioactive element dropped from 100 counts per second to 12.5 counts per second in 9 years. Find the half-life period of the element. (3 marks)

16. (a) (i) What do you understand by the term 'doping' with regard to semiconductors? (1 mark)  
 (ii) Explain briefly the process of producing a n-type and a p-type semiconductor. (2 marks)  
 (iii) Explain how the conductivity of a semiconductor changes with temperature. (1 mark)
- (b) (i) State two factors that affect photoelectric emission. (2 marks)  
 (ii) The maximum kinetic energy of a photoelectron emitted from a metal surface is  $9.95 \times 10^{-20}$  Joules. If the threshold frequency of light required to cause photoelectric emission with this metal is  $5 \times 10^{14}$  Hz, calculate the frequency of the incident radiation (Planck's constant =  $6.63 \times 10^{-34}$  Js). (3 marks)
- (c) The graph below shows the relationship between the maximum kinetic energy of the photoelectrons emitted from a certain metal surface and the wavelength of the incident radiation.

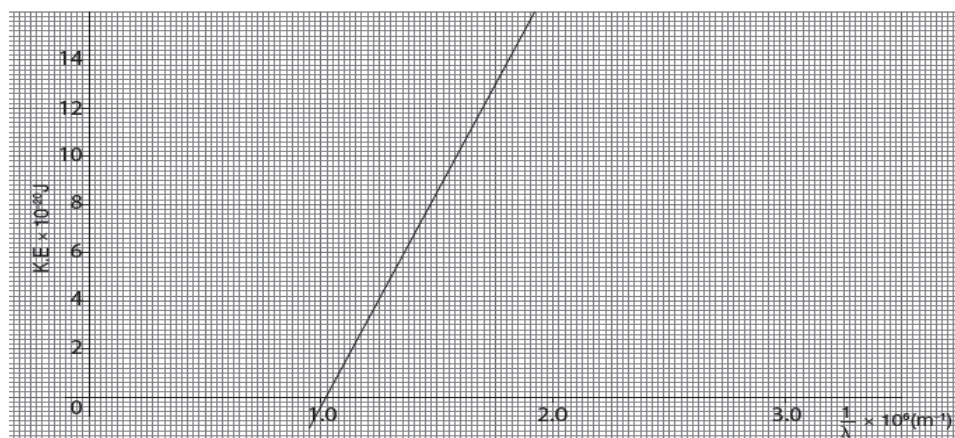

From the graph, find:

- (i) the threshold wavelength of the incident radiation. (2 marks)



(ii) the work function of the metal surface.

Planck's constant =  $6.63 \times 10^{-34}$  Js

Velocity of light =  $3 \times 10^8$  m/s

(3 marks)

17. (a) A coin was dropped into a water bucket of depth 60 cm. Given that the refractive index of water is 1.2, determine the vertical displacement of the coin when viewed from above. (2 marks)

(b) The figure below shows the path of a ray of light passing through a glass prism. Given that the speed of the light is  $2.0 \times 10^8$  m/s,

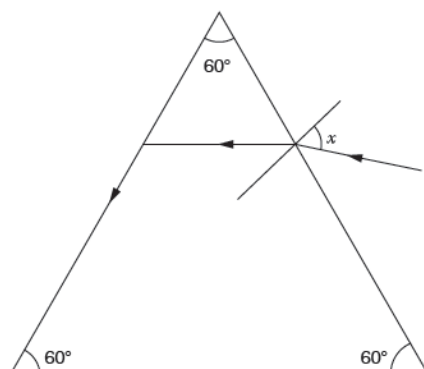

(i) calculate the refractive index of the prism material given that  $c = 3.0 \times 10^8$  m/s. (2 marks)

(ii) work out the critical angle of the prism and show it on the figure. (2 marks)

(iii) State two applications of the prism. (2 marks)

(c) Given that  ${}_a n_w = \frac{4}{3}$  and  ${}_a n_g = 1.5$ , work out  ${}_w n_g$ .

(d) Explain why the sun can be seen before it rises above the horizon. (2 marks)