

**TERM 2 2022 OPENER EXAM FORM 4
PHYSICS PAPER 2 FORM FOUR**

NAME.....MARKING SCHEME.....ADM NO:.....CLASS.....

SECTION A (25 MARKS)

Answer All questions in this section in the spaces provided

- Briefly explain how polarization can be overcome in a simple cell (1mark)
- Determine the angle of reflection r in the diagram below(3marks)

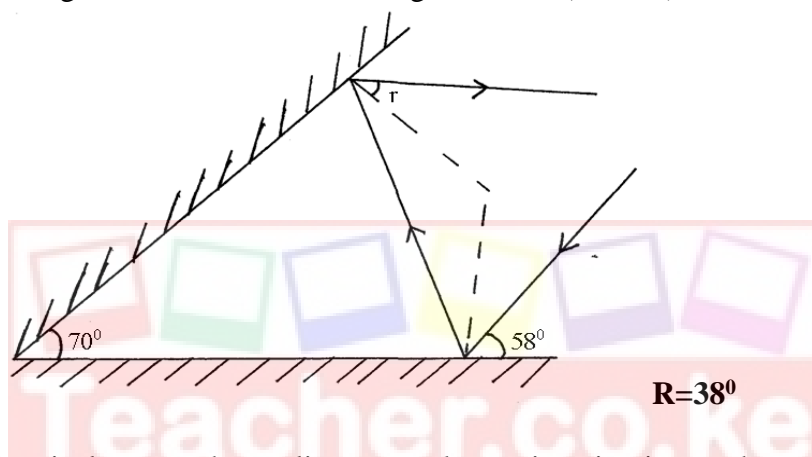

- In a house electrical system the appliances used on a ring circuit must have their plugs with fuses. Explain how the fuse protects the appliances used.(1mark)

Fuses are used to safeguard against excess current. Disconnecting the circuit when the currents exceed the fuse rating

- Four 10Ω resistors are connected to a 10V dc supply as shown in the diagram below.

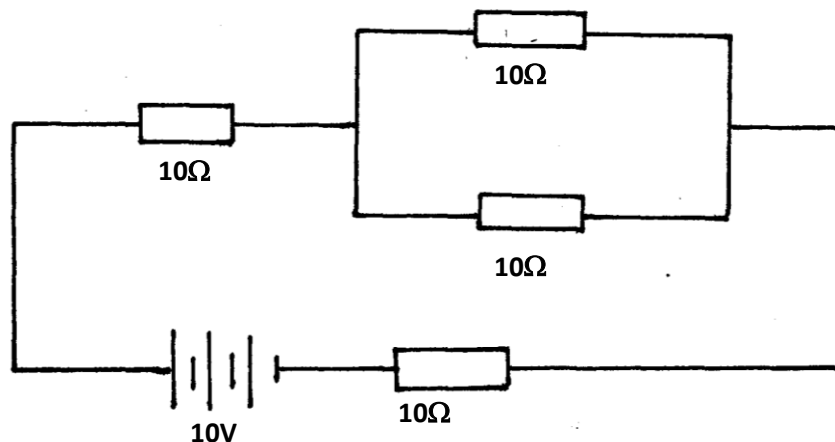

Calculate the total current flowing in the circuit. (3marks)

$I=0.4A$

5. A steel is to be magnetized by electrical method as shown below. Identify the pole **P** and **Q** of the resulting magnet.(2marks)

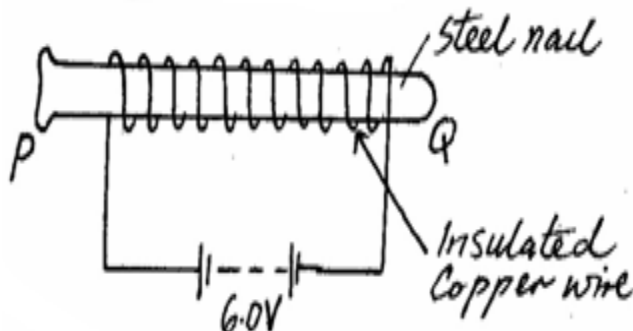

6. An object **O** is placed in front of a concave mirror and on the principal axis, as shown in the figure **below**. Complete the light ray diagram to locate the position of the image. (3marks)



7. Arrange the following electromagnetic waves in order of increasing frequency; Visible light; Gamma rays; Ultraviolet rays and Microwaves (1 mark)

Microwaves; visible light; ultraviolet; gamma rays

8. A charged conductor is slowly brought near the cap of a positively charged electroscope. The leaf first collapses and then diverges. Explain(2marks)

9. The circuit diagram in figure13 below shows four capacitors connected between two points **A** and **B**. Determine the capacitance across **AB**. (3mks)

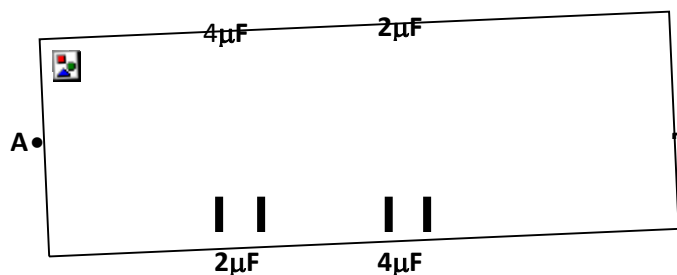

$2.667\mu F$

10. The figure below shows a conductor carrying current placed within the magnetic field of two magnets. Complete the diagram by showing the field pattern and the direction of force F that acts on the conductor. (2 marks)



11. Explain why electric power is transmitted over long distances at high voltages. (1 mark)

To minimize power loss in transmission cables

12. (a) Define diffraction with respect to waves. (1 mark)

Phenomenon which occurs when waves go around an obstacle or through a slit

- (b) In the diagram below the size of the aperture at the barrier is 10cm while the distance between two consecutive wave fronts is 3cm. If the waves are moving towards the barrier, draw the wave fronts as they appear after passing through the aperture. (2 marks)

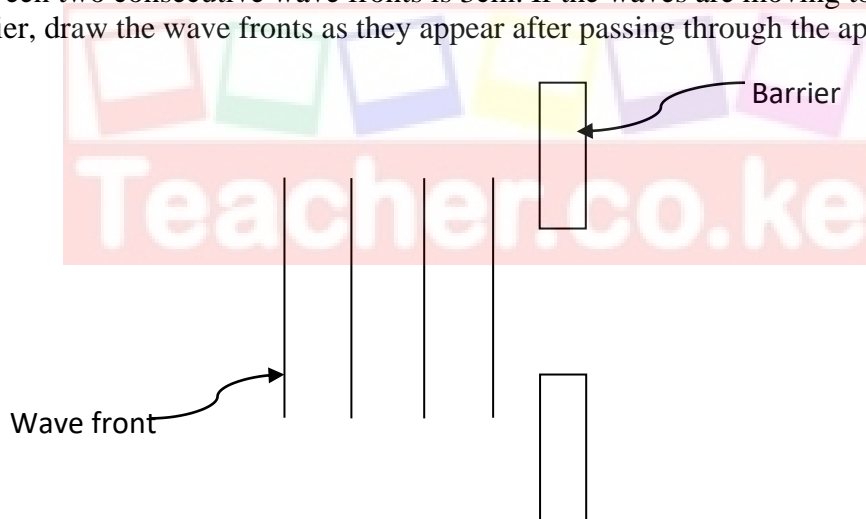

SECTION B (55 MARKS)

Answer all questions in this section in the spaces provided

13. a) State Faraday's Law of electromagnetic induction.(1mark)

The magnitude of the induced emf is directly proportional to the rate of change of magnetic flux linkage

b) An Armature composed of turns of insulated copper wire wound on a soft iron core is rotated in a magnetic field to produce an e.m.f. Other than the speed of rotation, state two other factors that affect the magnitude of the generated e.m.f (2marks)

Strength of the magnetic field
Number of turns in the coil

c) Briefly explain why the soft iron is laminated.(1mark)

To reduce eddy currents

d) A transformer with 500turns in the primary and 50 turns in the secondary is connected to 240V a.c. mains. If a 50Ω resistor is connected to the secondary coil, determine the energy dissipated by this resistor if the transformer is 100% efficient. (3marks)

e) Give one major difference between a step up transformer and step down transformer. (1 mark)

Step up $N_S > N_P$

Step down $N_P > N_S$

f) The diagram below shows an induction coil used in the car ignition system.

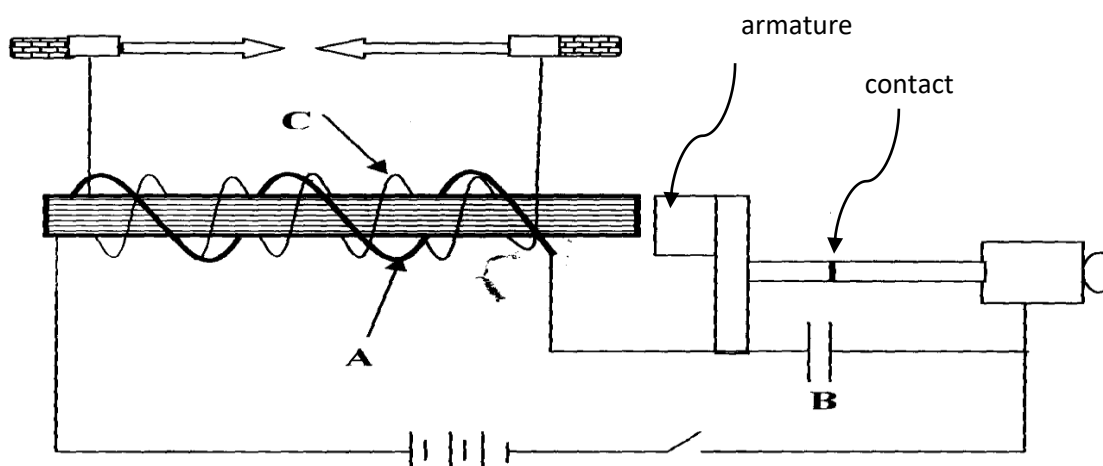

- (i) Name parts labelled A and B. (2 marks)

A Primary coil.(few turns)

B Capacitor

- (ii) Give the function of B. (1mark)

To minimize the sparking and causes the primary current and hence magnetic flux to decay to zero

14. (a) (i) What is the difference between stationary and progressive waves (2marks)

- (ii) State two distinctions between the way mechanical waves and electromagnetic waves are transmitted.(2marks)

Mechanical waves require material medium for transmission

Electromagnetic waves do not require a material medium for transmission

(b) A student stands between two halls and 400m from the nearest hall. The halls are x metres apart. Every time the student claps, two echoes are heard by the student such that the first echo comes after 2.5 seconds while the second follows 2 seconds later. From this information calculate.

- (i) The speed of sound in air. (3marks)

400m/s

- (ii) The value of x. (3marks)

1840m/s

- (c) Explain the effect of temperature of air on the speed of sound. (1mark)

Directly proportional

15. a) Define the term critical angle. (1mk)

angle of incidence in the denser medium for which the angle of refraction in the less dense medium is 90°

b) The critical angle of a certain material medium is 43.2° . Determine the refractive index of the material.(2marks)

$n=1.461$

c) The following results were obtained in an experiment to determine the reactive index of as certain liquid.

Real depth (mm)	40.5	60	80	100
Apparent depth (mm)	29.5	45	60	75.5

(i) Plot a graph of apparent depth against the real depth.(4marks)

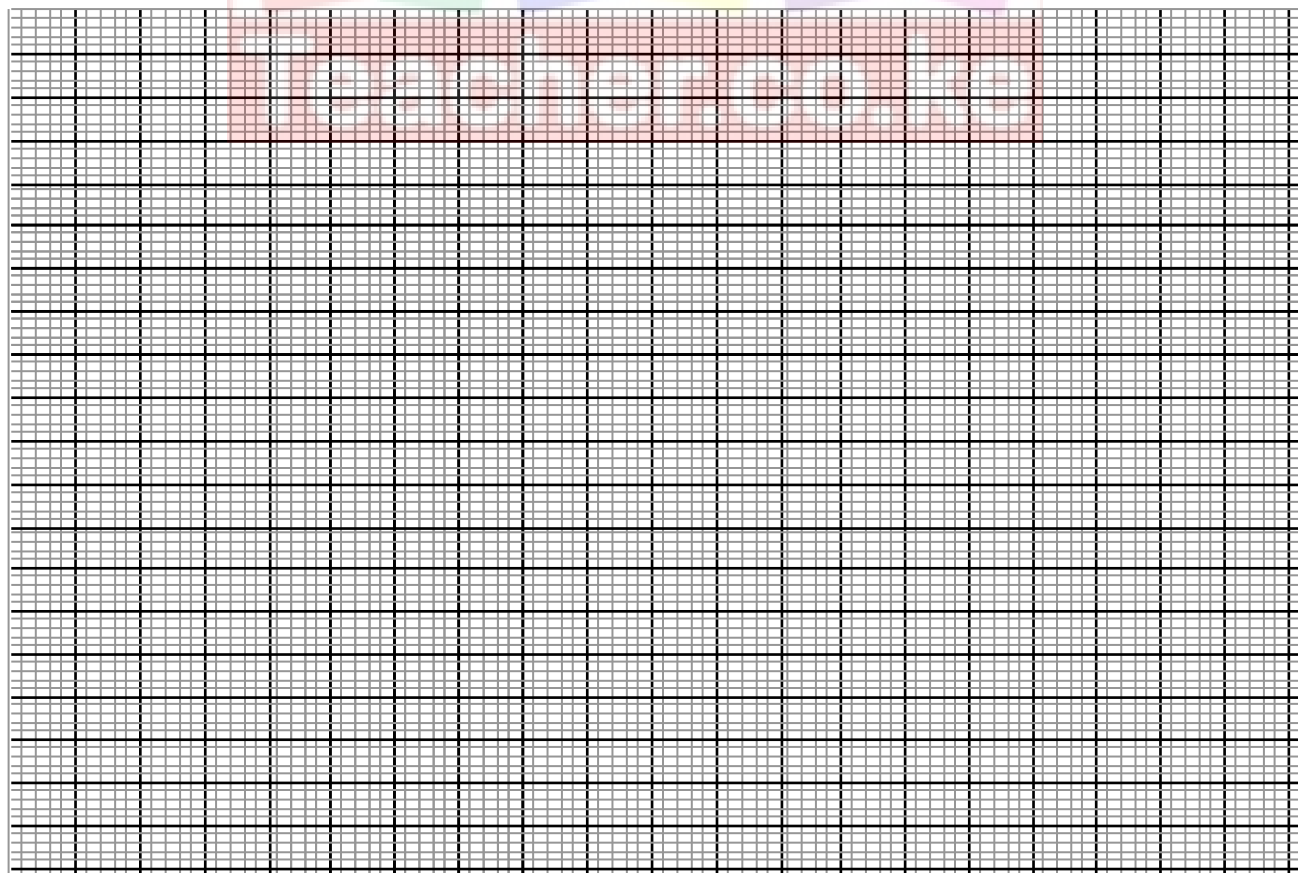

(i) From the graph, determine the refractive index of the liquid. (2mks)

(ii) Identify the liquid. (1mk)

d) Give two conditions necessary for total internal reflection to occur. (2marks)

light must be travelling from denser medium to a less medium
angle of incidence must be exceed the critical angle

16. a) Differentiate between electromotive force (e.m.f) and potential difference (2marks)

b) The figure shows the electric wiring of an electric cooker X, Y and Z are main wires.

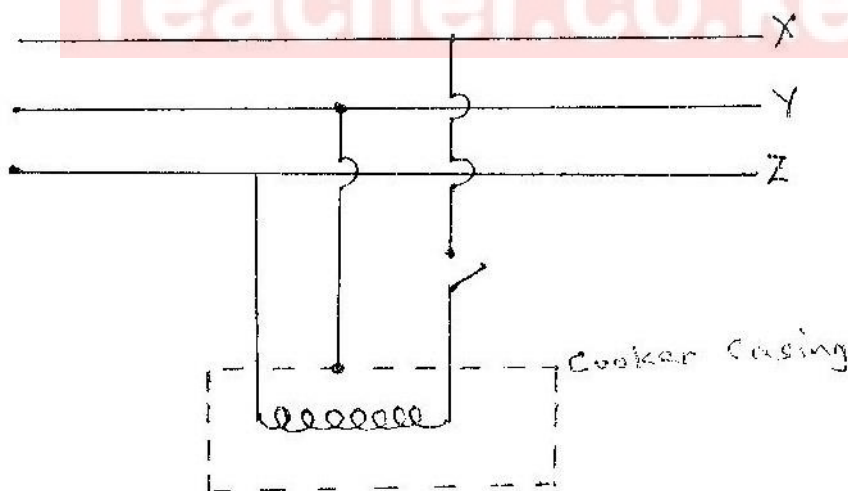

Giving a reason, identify X and Y. (2 marks)

X Live wire presence of a switch

Y Earth wire connected to the metal casing

c) A student has a large number of 240V, 60W coloured bulbs he wishes to use for decorations so that the bulbs operate normally.

(i). How many bulbs can be connected to a 240V supply through a 5A fuse
(2 marks)

(ii). If electric energy cost Kshs. 6.75 per unit, what will be the cost of running the above circuit for 5 hours a night for 20 nights?(2 marks)

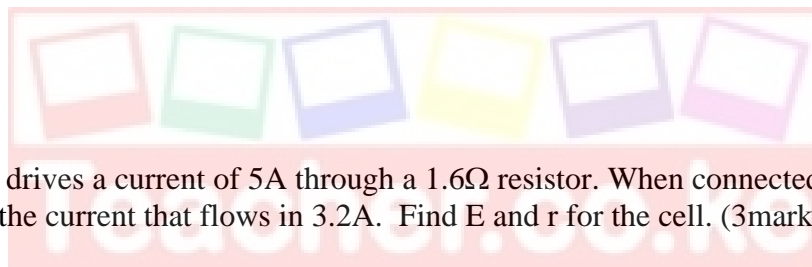

e) A cell drives a current of 5A through a 1.6Ω resistor. When connected to a 2.8Ω resistor, the current that flows in 3.2A. Find E and r for the cell. (3marks)

$r=0.5333$
 $E=10.67V$

b) Calculate the length of a nichrome resistance wire of cross-sectional area $7 \times 10^{-8}m^2$ required to make a resistor of 10 ohms. (Take resistivity of nichrome = $1.10 \times 10^{-6}\Omega m$).
(3 marks)

0.6364cm

17. a) Define the term accommodation as used in lenses.(1mk)

fine adjustment to accommodate images of objects at different distances on the retina by the lens

b) (i) Identify the defect.(1mk)

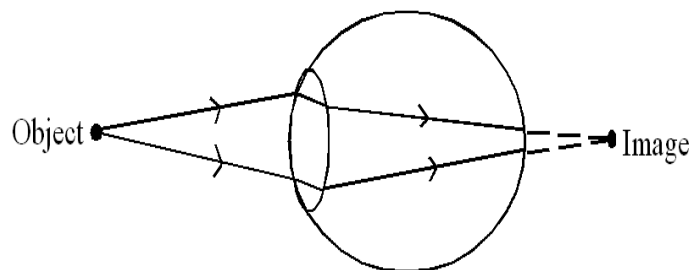

(iii) State how the defect can be corrected (1mark)

Use of converging lens

c) Give one difference between the eye and the camera.(1mark)

Eye	camera
Variable focal length	Fixed focal length
Variable image distance	Constant image distance

d) An object of height 10cm stands before a diverging lens of focal length 30cm and at a distance of 20cm from the lens. Determine the image distance and state two characteristics of the image formed. (3 marks)

**$v = -12\text{cm}$ same side as the objects
virtual image**