

232/2

— **PHYSICS** —
(THEORY)

Paper 2

Apr. 2021 – 2 hours

Name Index Number

Candidate's Signature Date

Instructions to candidates

- (a) Write your name and index number in the spaces provided above.
- (b) Sign and write the date of examination in the spaces provided above.
- (c) This paper consists of **two** sections; **A** and **B**.
- (d) Answer **all** the questions in sections **A** and **B** in the spaces provided.
- (e) **All** working **must** be clearly shown in the spaces provided in this booklet.
- (f) Non-programmable silent electronic calculators may be used.
- (g) **This paper consists of 14 printed pages.**
- (h) **Candidates should check the question paper to ascertain that all the pages are printed as indicated and that no questions are missing.**
- (i) **Candidates should answer the questions in English.**

For Examiner's Use Only

Section	Question	Maximum Score	Candidate's Score
A	1–13	25	
B	14	9	
	15	11	
	16	11	
	17	13	
	18	11	
Total Score		80	



Teacher.co.ke

700

Download Notes & More Free Revision Materials at <https://teacher.co.ke/notes>



SECTION A (25 marks)

Answer **all** the questions in this section in the spaces provided

- 1. State the observation made on the image in a pin hole camera when the distance between the object and the pin hole is reduced. (2 marks)

.....

.....

.....

- 2. Figure 1 shows a gold leaf electroscope.

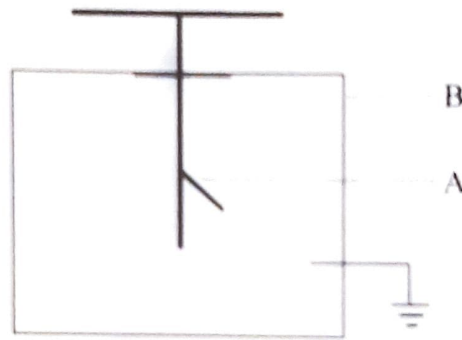

Figure 1

- (a) Name the part labelled A. (1 mark)

.....

- (b) State the function of the part labelled B. (1 mark)

.....

.....

- 3. State **two** measurements that should be taken for one to decide whether a lead acid accumulator is due for charging. (2 marks)

.....

.....



4. Explain what happens to the speed of a water wave as it moves from the shallow to the deep end in a ripple tank. (2 marks)

.....

.....

.....

5. The critical angle for a ray travelling from glass to air is 42° . Determine the refractive index of the glass. (3 marks)

.....

.....

.....

6. Figures 2(a) and 2(b) show two circuit diagrams with identical lamps and identical cells.

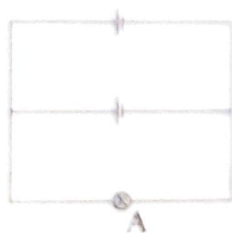

Figure 2(a)

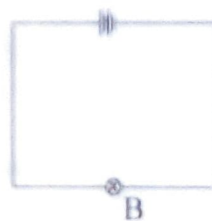

Figure 2(b)

State with a reason which of the bulbs will be brighter. (2 marks)

.....

.....

.....

7. **Figure 3** shows an annular ring.

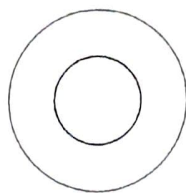

Figure 3

On the diagram, sketch the distribution of the charge on the ring, when the ring is negatively charged. (1 mark)

8. When iron filings are sprinkled onto a bar magnet, it is observed that there are more iron filings at the ends than in the middle. Explain this observation. (2 marks)

.....

.....

.....

.....

9. Draw a diagram to show a *p-n junction* connected in the reverse bias mode. (2 marks)

10. A broadcasting station produces radio waves of wavelength 800 m. Determine their frequency. (speed of air is $3 \times 10^8 \text{ ms}^{-1}$) (2 marks)

.....

.....

.....



11. Explain how x-rays are produced in the x-ray tube. (2 marks)

.....

.....

.....

12. State the purpose of a fuse in an electrical circuit. (1 mark)

.....

.....

.....

13. **Figure 4** shows circular water waves incident on a plane reflector placed at an angle to the path of the waves.

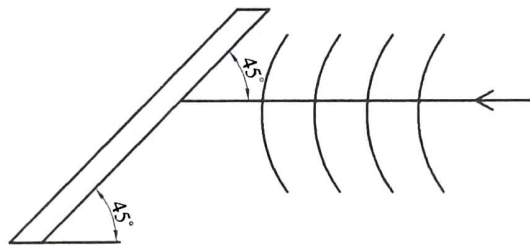

Figure 4

Complete the diagram to show the reflected waves. (2 marks)



SECTION B (55 marks)

Answer all the questions in this section in the spaces provided.



14. (a) State **two** ways of minimising power losses during the transmission of electric power. (1 mark)

.....

.....

.....

- (b) An electric cooker is rated 2.5 kW, 250 V. State the meaning of these values. (1 mark)

.....

.....

.....

- (c) A consumer has the following appliances in the house:

- *An electric iron rated 1500 W*
- *A water heater rated 500 W*
- *An electric cooker rated 2500 W*
- *Three bulbs each rated 60 W.*

The house is fitted with a 12 A fuse. Determine:

- (i) whether the consumer can connect all the appliances to the 240 V power supply at the same time; (4 marks)

.....

.....

.....

.....

.....

700

Download Notes & More Free Revision Materials at <https://teacher.co.ke/notes>

A060



(ii) the resistance of the heating element used in the electric cooker. (3 marks)

.....

.....

.....

.....

15. (a) Describe how the focal length of a concave mirror can be determined using a screen and a metre rule. (1 mark)

.....

.....

.....

.....

(b) An object is placed 8 cm from a concave mirror whose radius of curvature is 20 cm. Determine the position of the image. (3 marks)

.....

.....

.....



- (c) An object of height 10 cm is placed 30 cm from a converging lens of focal length 18 cm.
- (i) On the grid provided, draw a ray diagram to locate the position of the image formed. (3 marks)

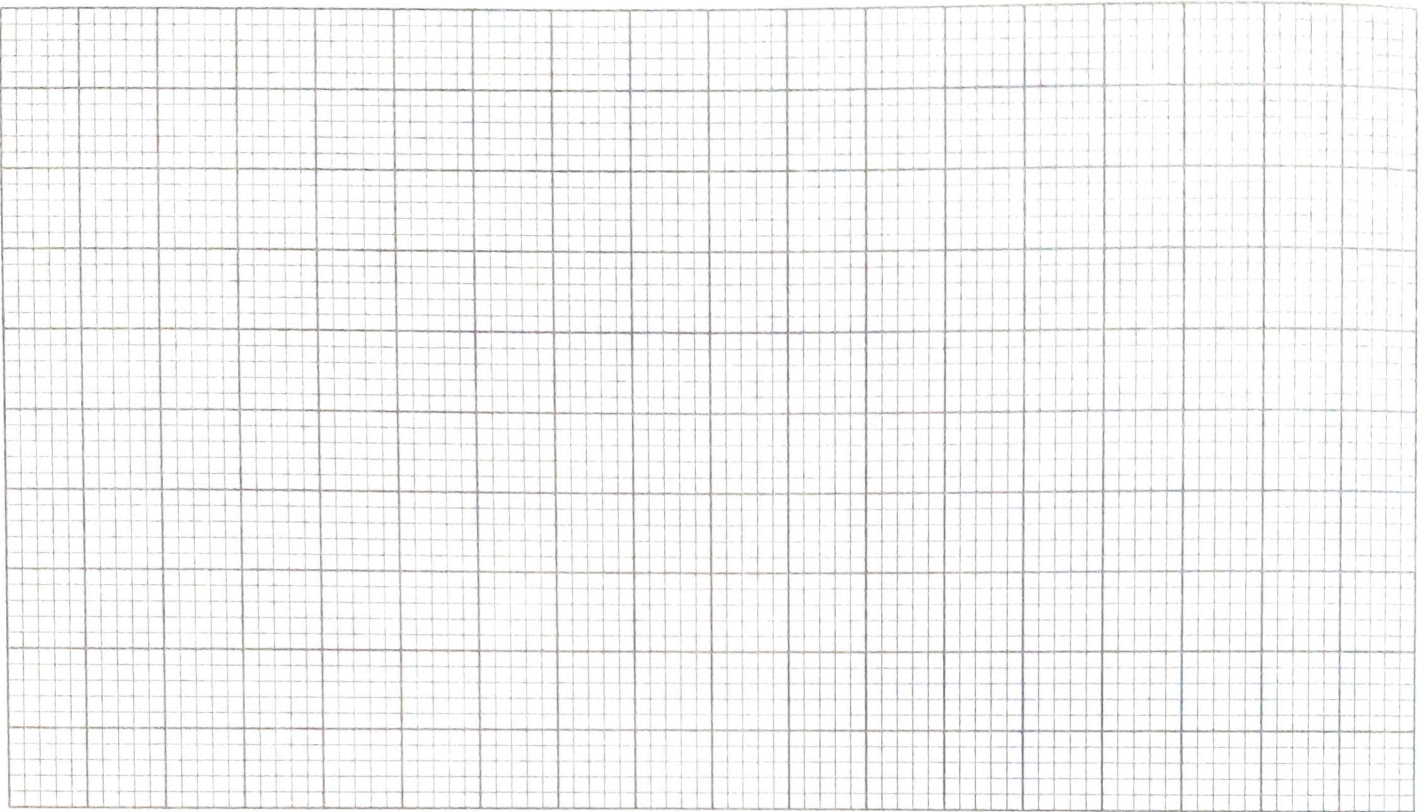

- (ii) From the diagram in part (i), determine the:
- I. image height; (2 marks)
-
-
-
- II. image distance. (2 marks)
-
-
-



16. (a) State **two** uses of radioactivity in medicine. (1 mark)

.....

.....

.....

(b) The following is a nuclear reaction equation: ${}^6_3\text{Li} + {}^1_0\text{n} \rightarrow {}^3_1\text{H} + {}^x_y\text{P}$
 Determine the values of x and y . (2 marks)

.....

.....

.....

(c) **Figure 5** shows a radioactive element placed in an evacuated glass chamber. The element produces alpha, beta and gamma emissions.

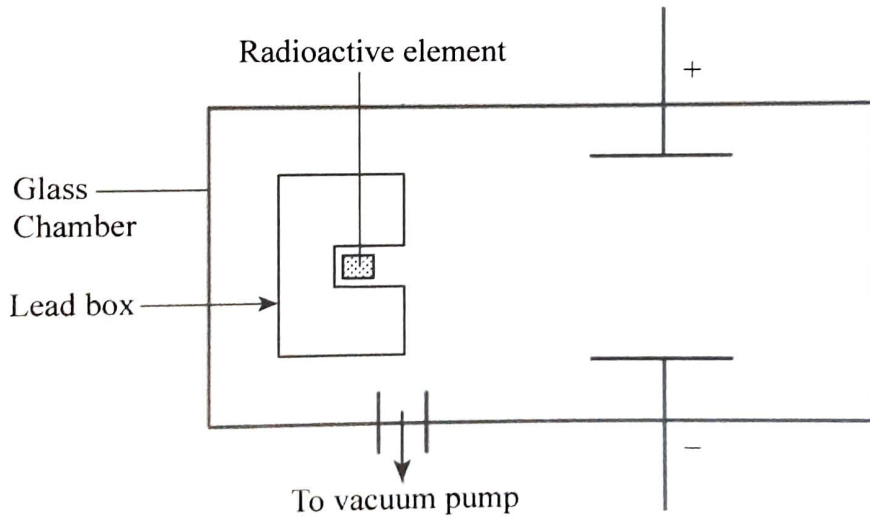

Figure 5

The three emissions pass through an electric field.

(i) Complete the diagram to show the path of each of the emissions. (3 marks)

(ii) State the reason why:

I. the radioactive element is kept inside a lead box; (1 mark)

.....

.....

II. the chamber is evacuated. (1 mark)

.....

.....

.....

(d) (i) Arrange the following electromagnetic waves in the order of decreasing frequency:
Microwaves; Gamma rays; Radiowaves; X-rays. (1 mark)

.....

.....

.....

(ii) The half life of a certain radioactive substance is 24 days. Given that the initial sample of the substance has a mass of 64 g, determine the mass which is left after 72 days. (2 marks)

.....

.....

.....

.....



17. (a) (i) Name the **three** components of the electron gun in a cathode ray tube.

(3 marks)

.....

.....

.....

- (ii) State **one** difference between the deflection systems of a cathode ray tube and the television tube.

(1 mark)

.....

.....

.....

- (b) **Figure 6** shows a graph of stopping potential against the frequency for a certain photo emissive surface, drawn by a student from the data collected when carrying out an experiment on photoelectric effect.

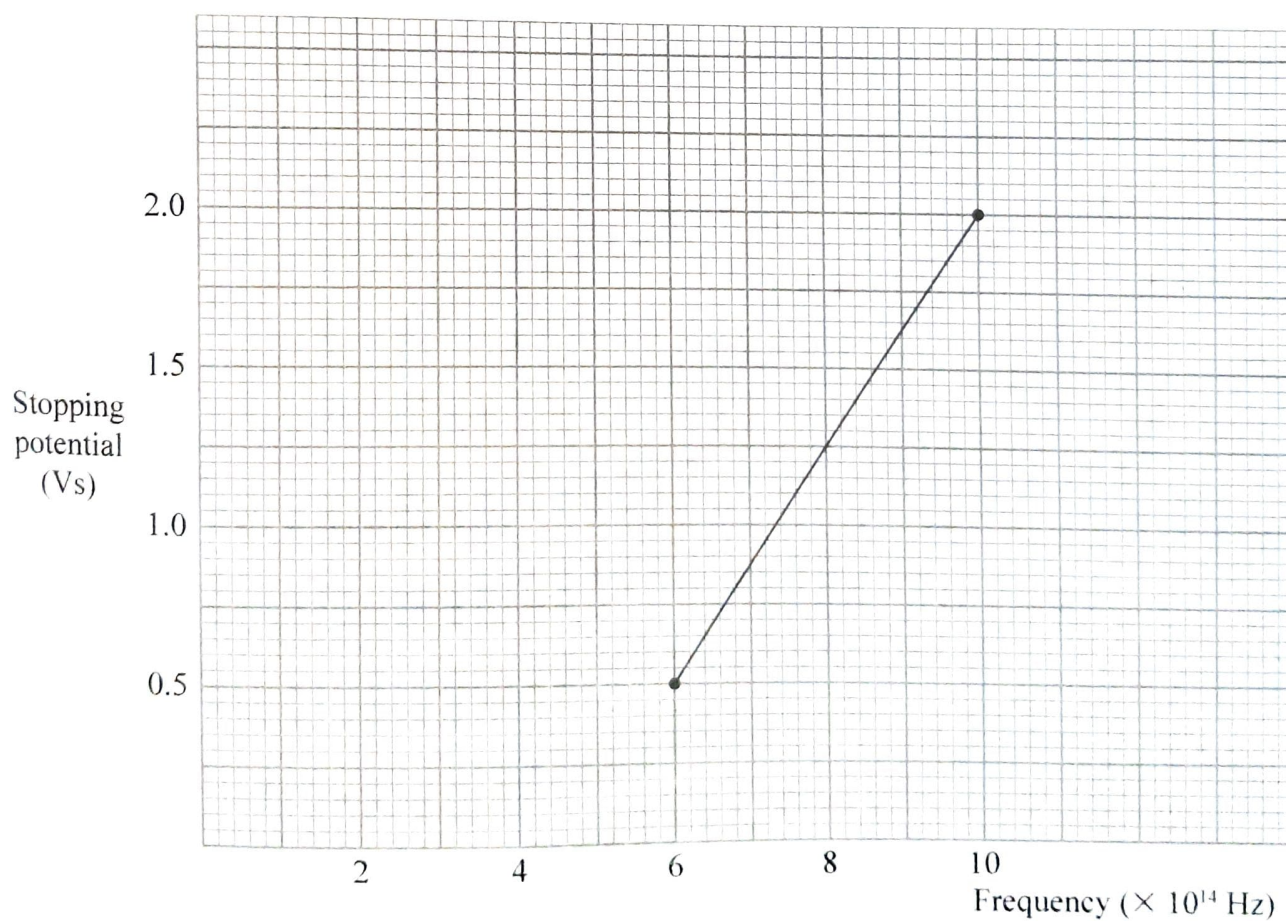

Figure 6

From the graph, determine the:

- (i) threshold frequency of the surface; (3 marks)

.....
.....
.....

- (ii) plank's constant h , given that the energy of the incident photon is $1.6 \times 10^{-19} \text{ J}$; (3 marks)

.....
.....
.....

- (iii) work function of the surface. (3 marks)

.....
.....
.....



700

Download Notes & More Free Revision Materials at <https://teacher.co.ke/notes>

A060



18. (a) **Figure 7** shows a soft iron ring placed between the poles of two bar magnets.

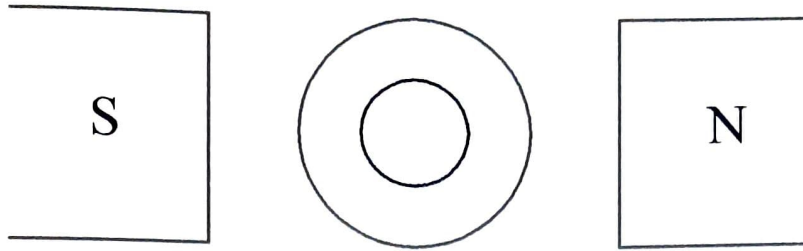

Figure 7

On the figure, draw the magnetic field lines between the poles. (2 marks)

- (b) **Figure 8** shows two straight conductors **P** and **Q** connected to a battery and a variable resistor.

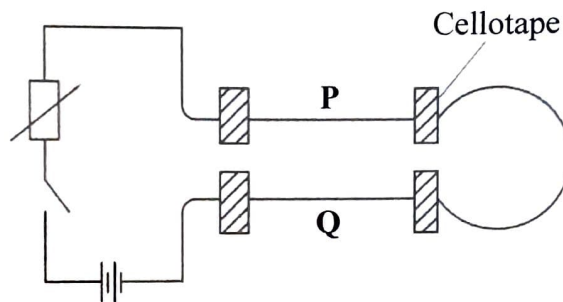

Figure 8

- (i) Using arrows, indicate on the diagram the direction of current that flows through **P** and **Q** when the switch is closed. (1 mark)
- (ii) State what is observed as the current flows through the conductors. (1 mark)

.....

.....

.....

(3 marks)

(iii) Explain the observation in (ii).

.....

.....

.....

.....

.....

.....

.....

(c) (i) State how eddy currents are minimised in a transformer.

(1 mark)

.....

.....

.....

(ii) A step down transformer has 600 turns in the primary coil. The input voltage is 120 V while the output voltage is 24 V. Determine the number of turns in the secondary coil.

(3 marks)

.....

.....

.....

.....

.....

THIS IS THE LAST PRINTED PAGE.



BLANK PAGE





BLANK PAGE