

PHYSICS FORM THREE

PAPER 3 (PRACTICAL)

QUESTION ONE

- a) Using 30cm thread, suspend the metre rule at the 50cm marks. You may use some plasticine to ensure that the balance is exactly at 50cm.
- b) Suspend the empty beaker at 40cm mark and hang the 50g mass to the other side

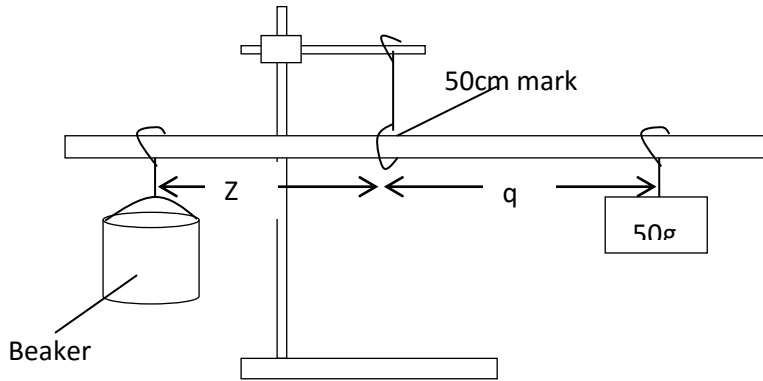

Move the 50g mass until the metre rule balances horizontally. Record the distance $q = \dots\dots\dots 7\text{cm}$ use student's value $\dots\dots\dots \text{cm}$ (1mrk)

- c) Repeat the procedure above for other values of volumes as shown in the table, hence complete it

Volume $V \text{ cm}^3$	0	20	40	60	80	100	120
Length $Z \text{ cm}$	10.0	7.0	5.0	4.0	3.5	3.0	2.5
$\frac{1}{z} \text{ cm}^{-1}$	0.10	0.14	0.20	0.25	0.29	0.33	0.40

(7mrks)

½ mrk for each

- d) Plot a graph of volume V against $\frac{1}{z}$ (5mrks)

Graph is a straight line

- e) Determine the slope S of the graph (3mrks)

Substitution 1mrk

Simplification 1mrk

Range 400 ± 8 1mrk

- f) From the equation $V = 1000 \frac{(50q)}{dz} - \frac{1000m}{d}$

Determine the values of

- i) d (2mrks)

$slope = \frac{50q}{d} 400 = \frac{50 \times 7}{d} d = 0.875 q$ is substituted, check student's working

- ii) m (2mrks)

$$y\text{-Intercept} = \frac{100m}{d}$$

Extrapolation 1mrk

Substitution 1mrk

QUESTION 2

- a) Connect the apparatus as shown below

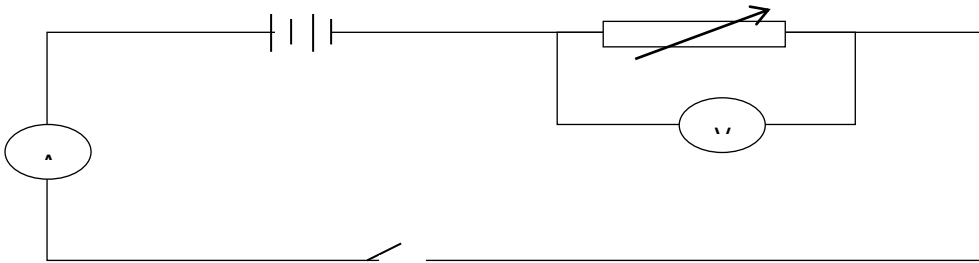

- b) Adjust the potentiometer until you are able to obtain minimum reading on the voltmeter and maximum on the ammeter. Record these readings in the table below.

V (V)	0.2	0.6	1.1	1.6	1.8	2.1 (increasing trend)
I (A)	0.18	0.12	0.10	0.08	0.06	0.04(decreasing trend)
$\frac{V}{I}$	Student's working					
$\frac{1}{I}$	Student's working					

(12mrks)

- c) By adjusting the potentiometer, obtain five more readings at an interval of 0.5V and complete the table

- d) Plot a graph of $\frac{V}{I}$ against $\frac{1}{I}$

(5mrks)

Graph is a straight line with a negative y- intercept

Axes labeled 1mrk

Scale simple and uniform 1mrk

Plotting 6pts 2mrks, 3 – 4pts 1mrk

Straight line 1mrk

- e) The equation for the graph is given by $\frac{V}{I} = \frac{E}{I} - k$ where E and k are constants. From the graph

determine the value of E and k .

(3mrks)

Slope of graph gives $E = 2.99V$ (slope 1mrk)

$K = y$ - intercept (positive value negative cancels)

Values of K and E 1mrk each